

eCELL FT & HS

ROBOTIC WELDING SYSTEMS

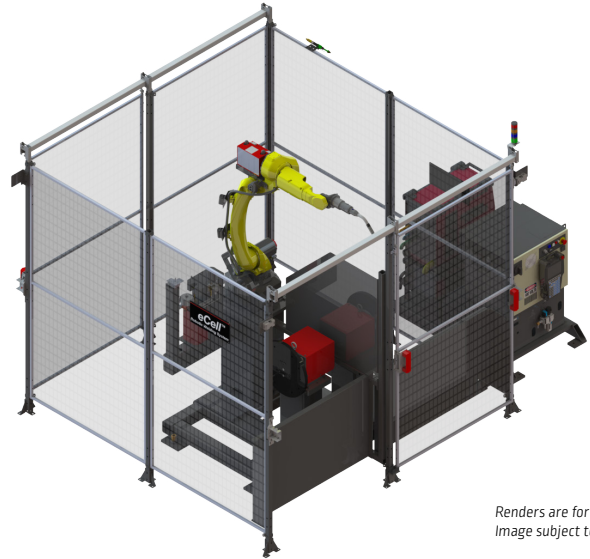

AD2530-1 eCELL FT air-cooled system



AD2530-4eCELL HS water-cooled system

*Renders are for reference only
Image subject to change*

eCELL FT & HS ROBOTIC WELDING SYSTEMS

The eCell™ systems are engineered to be cost-effective robotic welding systems with a small footprint. These robotic welding systems are ideal for job-shop environments, contract manufacturers, and first-time automation users due to minimal programming requirements. The off-the-shelf design helps provide a faster return on investment with lead times as quick as one week for select models!

SYSTEM INCLUDES

- Power Wave® R450 power source
- AutoDrive® 4R100 wire drive
- Magnum® PRO robotic torch
- Power Ream® II torch maintenance unit
- FANUC® robot
- Fixed table (FT) or headstock (HS) positioner (depending on model)
- Robot basic software package

BENEFITS

- Full welding capabilities with a small robot arm and system footprint
- Minimal installation
- ANSI/RIA safety compliant

OPTIONS AVAILABLE

- Water-cooled torch
- Power Ream® II torch maintenance unit upgrade
- Touchscreen HMI upgrade
- Hood or on-torch fume extraction
- Tooling tables and beams
- Tooling clamp kit
- Virtual or in-person training

INDUSTRY

- High-mix, low-volume manufacturing

CONTACT LINCOLN ELECTRIC AUTOMATION - CLEVELAND



22221 St. Clair Ave
Euclid, OH 44117



+1 [216] 383-2959



lincolnelectric.com

Publication LEA-062124TM1-00

© Lincoln Global Inc. All Rights Reserved. All trademarks and registered trademarks are the property of their respective owners.
www.lincolnelectric.com/automation



AD2530-1 eCELL FT air-cooled system

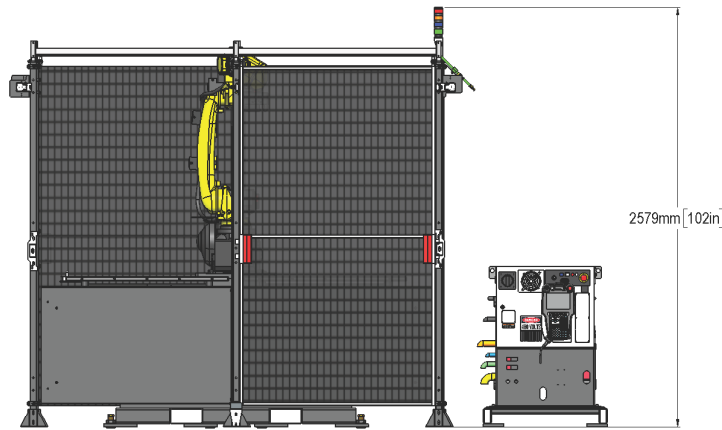
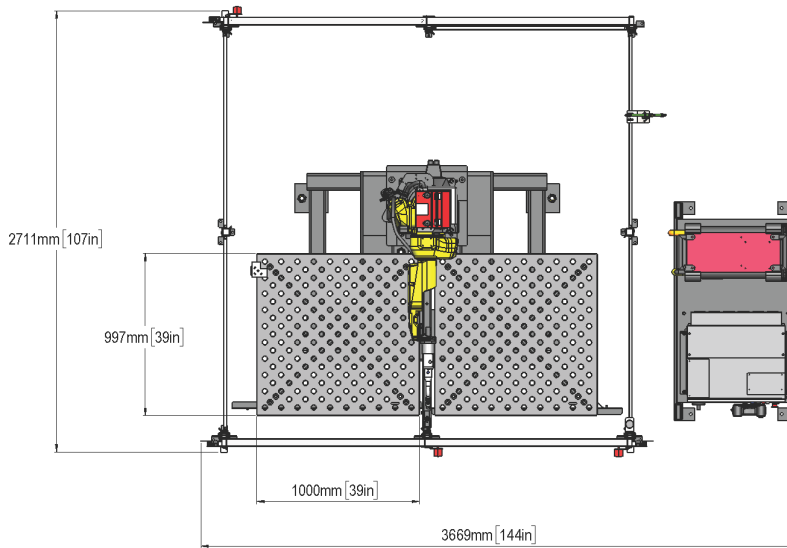

PRODUCT SPECIFICATIONS

Product Number	Model Name	Software Type	Positioner Type	Torch Type	Positioner Capacity (kg)	Span (mm)	Swing (mm)	Wire Feeder	Robot Arm	Qty of Robots
AD2530-1	eCELL FT	FANUC	Fixed Table	Air-Cooled	500	N/A	N/A	4R100	FANUC	1
AD2530-2	eCELL FT	FANUC	Fixed Table	Water-Cooled	500	N/A	N/A	4R100	FANUC	1
AD2530-3	eCELL HS	FANUC	Headstock	Air-Cooled	500	750	750	4R100	FANUC	1
AD2530-4	eCELL HS	FANUC	Headstock	Water-Cooled	500	750	750	4R100	FANUC	1

Important Note: Changes from recommended motor sizing, payload, duty cycles, cable routing, weld grounding (if applicable), other system specifications [i.e. servo parameters, controller stop parameter], and/or modifications may affect cycle times and overall performance. User assumes all responsibility for proper rigging, installation, and machine setting alignments of product(s). Manufacturer's warranty is void to the extent any failure caused by improper installation, modification, or operation by customer.

CUSTOMER ASSISTANCE POLICY

The business of Lincoln Electric is manufacturing and selling high quality welding equipment, automated welding systems, consumables, and cutting equipment. Our challenge is to meet the needs of our customers, who are experts in their fields, and to exceed their expectations. On occasion, purchasers may ask Lincoln Electric for information or technical information about their use of our products. Our employees respond to inquiries to the best of their ability based on information and specifications provided to them by the customers and the knowledge they may have concerning the application. Our employees, however, are not in a position to verify the information provided or to evaluate the engineering requirements for the particular weldment, or to provide engineering advice in relation to a specific situation or application. Accordingly, Lincoln Electric does not warrant or guarantee or assume any liability with respect to such information or communications. Moreover, the provision of such information or technical information does not create, expand, or alter any warranty on our products. Any express or implied warranty that might arise from the information or technical information, including any implied warranty of merchantability or any warranty of fitness for any customers' particular purpose or any other equivalent or similar warranty is specifically disclaimed.

Lincoln Electric is a responsive manufacturer, but the definition of specifications, and the selection and use of specific products sold by Lincoln Electric is solely within the control of, and remains the sole responsibility of the customer. Many variables beyond the control of Lincoln Electric affect the results obtained in applying these types of fabrication methods and service requirements.

THE LINCOLN ELECTRIC COMPANY
 22801 Saint Clair Avenue · Cleveland, OH · 44117 · U.S.A.
 Phone: +1 216.481.8100 · www.lincolnelectric.com