

SP-100

OPERATOR'S MANUAL

For use with machines having Code Number 9284 and above.

9284; 9429; 9521; 9522; 9725;
9726; 9794; 9795; 10050

Safety Depends on You

Lincoln arc welding equipment is designed and built with safety in mind. However, your overall safety can be increased by proper installation ... and thoughtful operation on your part. **DO NOT INSTALL OPERATE OR REPAIR THIS EQUIPMENT WITHOUT READING THIS MANUAL AND THE SAFETY PRECAUTIONS CONTAINED THROUGHOUT.** And, most importantly, think before you act and be careful.



This manual covers equipment which is obsolete and no longer in production by The Lincoln Electric Co. Specifications and availability of optional features may have changed.



World's Leader in Welding and Cutting Products

Premier Manufacturer of Industrial Motors

Sales and Service through Subsidiaries and Distributors Worldwide
22801 St. Clair Ave. Cleveland, Ohio 44117-1199 U.S.A. Tel. (216) 481-8100



WARNING

ARC WELDING can be hazardous.

PROTECT YOURSELF AND OTHERS FROM POSSIBLE SERIOUS INJURY OR DEATH. KEEP CHILDREN AWAY. PACEMAKER WEARERS SHOULD CONSULT WITH THEIR DOCTOR BEFORE OPERATING.

Read and understand the following safety highlights. For additional safety information it is strongly recommended that you purchase a copy of "Safety in Welding & Cutting - ANSI Standard Z49.1" from the American Welding Society, P.O. Box 351040, Miami, Florida 33135 or CSA Standard W117.2-1974. A **Free** copy of "Arc Welding Safety" booklet E205 is available from the Lincoln Electric Company, 22801 St. Clair Avenue, Cleveland, Ohio 44117-1199.

BE SURE THAT ALL INSTALLATION, OPERATION, MAINTENANCE, AND REPAIR PROCEDURES ARE PERFORMED ONLY BY QUALIFIED INDIVIDUALS.



ELECTRIC SHOCK can kill.

- 1.a. The electrode and work (or ground) circuits are electrically "hot" when the welder is on. Do not touch these "hot" parts with your bare skin or wet clothing. Wear dry, hole-free gloves to insulate hands.
- 1.b. Insulate yourself from work and ground using dry insulation. Make certain the insulation is large enough to cover your full area of physical contact with work and ground.

In addition to the normal safety precautions, if welding must be performed under electrically hazardous conditions (in damp locations or while wearing wet clothing; on metal structures such as floors, gratings or scaffolds; when in cramped positions such as sitting, kneeling or lying, if there is a high risk of unavoidable or accidental contact with the workpiece or ground) use the following equipment:

 - Semiautomatic DC Constant Voltage (Wire) Welder.
 - DC Manual (Stick) Welder.
 - AC Welder with Reduced Voltage Control.
- 1.c. In semiautomatic or automatic wire welding, the electrode, electrode reel, welding head, nozzle or semiautomatic welding gun are also electrically "hot".
- 1.d. Always be sure the work cable makes a good electrical connection with the metal being welded. The connection should be as close as possible to the area being welded.
- 1.e. Ground the work or metal to be welded to a good electrical (earth) ground.
- 1.f. Maintain the electrode holder, work clamp, welding cable and welding machine in good, safe operating condition. Replace damaged insulation.
- 1.g. Never dip the electrode in water for cooling.
- 1.h. Never simultaneously touch electrically "hot" parts of electrode holders connected to two welders because voltage between the two can be the total of the open circuit voltage of both welders.
- 1.i. When working above floor level, use a safety belt to protect yourself from a fall should you get a shock.
- 1.j. Also see Items 4.c. and 6.



FUMES AND GASES can be dangerous.

- 3.a. Welding may produce fumes and gases hazardous to health. Avoid breathing these fumes and gases. When welding, keep your head out of the fume. Use enough ventilation and/or exhaust at the arc to keep fumes and gases away from the breathing zone. **When welding with electrodes which require special ventilation such as stainless or hard facing (see instructions on container or MSDS) or on lead or cadmium plated steel and other metals or coatings which produce highly toxic fumes, keep exposure as low as possible and below Threshold Limit Values (TLV) using local exhaust or mechanical ventilation. In confined spaces or in some circumstances, outdoors, a respirator may be required. Additional precautions are also required when welding on galvanized steel.**
 - 3.b. Do not weld in locations near chlorinated hydrocarbon vapors coming from degreasing, cleaning or spraying operations. The heat and rays of the arc can react with solvent vapors to form phosgene, a highly toxic gas, and other irritating products.
 - 3.c. Shielding gases used for arc welding can displace air and cause injury or death. Always use enough ventilation, especially in confined areas, to insure breathing air is safe.
 - 3.d. Read and understand the manufacturer's instructions for this equipment and the consumables to be used, including the material safety data sheet (MSDS) and follow your employer's safety practices. MSDS forms are available from your welding distributor or from the manufacturer.
 - 3.e. Also see item 7b.

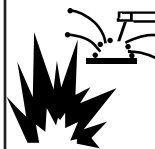

WELDING SPARKS can cause fire or explosion.

- 4.a. Remove fire hazards from the welding area. If this is not possible, cover them to prevent the welding sparks from starting a fire. Remember that welding sparks and hot materials from welding can easily go through small cracks and openings to adjacent areas. Avoid welding near hydraulic lines. Have a fire extinguisher readily available.
- 4.b. Where compressed gases are to be used at the job site, special precautions should be used to prevent hazardous situations. Refer to "Safety in Welding and Cutting" (ANSI Standard Z49.1) and the operating information for the equipment being used.
- 4.c. When not welding, make certain no part of the electrode circuit is touching the work or ground. Accidental contact can cause overheating and create a fire hazard.
- 4.d. Do not heat, cut or weld tanks, drums or containers until the proper steps have been taken to insure that such procedures will not cause flammable or toxic vapors from substances inside. They can cause an explosion even though they have been "cleaned." For information purchase "Recommended Safe Practices for the Preparation for Welding and Cutting of Containers and Piping That Have Held Hazardous Substances", AWS F4.1 from the American Welding Society (see address above).
- 4.e. Vent hollow castings or containers before heating, cutting or welding. They may explode.

ARC RAYS can burn.



- 2.a. Use a shield with the proper filter and cover plates to protect your eyes from sparks and the rays of the arc when welding or observing open arc welding. Headshield and filter lens should conform to ANSI Z87.1 standards.
- 2.b. Use suitable clothing made from durable flame-resistant material to protect your skin and that of your helpers from the arc rays.
- 2.c. Protect other nearby personnel with suitable non-flammable screening and/or warn them not to watch the arc nor expose themselves to the arc rays or to hot spatter or metal.

4.f. Sparks and spatter are thrown from the welding arc. Wear oil free protective garments such as leather gloves, heavy shirt, cuffless trousers, high shoes and a cap over your hair. Wear ear plugs when welding out of position or in confined places. Always wear safety glasses with side shields when in a welding area.

4.g. Connect the work cable to the work as close to the welding area as practical. Work cables connected to the building framework or other locations away from the welding area increase the possibility of the welding current passing through lifting chains, crane cables or other alternate circuits. This can create fire hazards or overheat lifting chains or cables until they fail.

4.h. Also see item 7c.

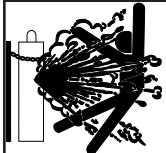

CYLINDER may explode if damaged.

5.a. Use only compressed gas cylinders containing the correct shielding gas for the process used and properly operating regulators designed for the gas and pressure used. All hoses, fittings, etc. should be suitable for the application and maintained in good condition.

5.b. Always keep cylinders in an upright position securely chained to an undercarriage or fixed support.

5.c. Cylinders should be located:

- Away from areas where they may be struck or subjected to physical damage.
- A safe distance from arc welding or cutting operations and any other source of heat, sparks, or flame.

5.d. Never allow the electrode, electrode holder or any other electrically "hot" parts to touch a cylinder.

5.e. Keep your head and face away from the cylinder valve outlet when opening the cylinder valve.

5.f. Valve protection caps should always be in place and hand tight except when the cylinder is in use or connected for use.

5.g. Read and follow the instructions on compressed gas cylinders, associated equipment, and CGA publication P-1, "Precautions for Safe Handling of Compressed Gases in Cylinders," available from the Compressed Gas Association 1235 Jefferson Davis Highway, Arlington, VA 22202.



FOR ELECTRICALLY powered equipment.

6.a. Turn off input power using the disconnect switch at the fuse box before working on the equipment.

6.b. Install equipment in accordance with the U.S. National Electrical Code, all local codes and the manufacturer's recommendations.

6.c. Ground the equipment in accordance with the U.S. National Electrical Code and the manufacturer's recommendations.



FOR ENGINE powered equipment.

7.a. Turn the engine off before troubleshooting and maintenance work unless the maintenance work requires it to be running.



7.b. Operate engines in open, well-ventilated areas or vent the engine exhaust fumes outdoors.



7.c. Do not add the fuel near an open flame welding arc or when the engine is running. Stop the engine and allow it to cool before refueling to prevent spilled fuel from vaporizing on contact with hot engine parts and igniting. Do not spill fuel when filling tank. If fuel is spilled, wipe it up and do not start engine until fumes have been eliminated.



7.d. Keep all equipment safety guards, covers and devices in position and in good repair. Keep hands, hair, clothing and tools away from V-belts, gears, fans and all other moving parts when starting, operating or repairing equipment.

7.e. In some cases it may be necessary to remove safety guards to perform required maintenance. Remove guards only when necessary and replace them when the maintenance requiring their removal is complete. Always use the greatest care when working near moving parts.

7.f. Do not put your hands near the engine fan. Do not attempt to override the governor or idler by pushing on the throttle control rods while the engine is running.

7.g. To prevent accidentally starting gasoline engines while turning the engine or welding generator during maintenance work, disconnect the spark plug wires, distributor cap or magneto wire as appropriate.

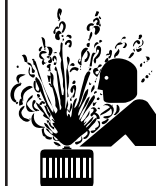

7.h. To avoid scalding, do not remove the radiator pressure cap when the engine is hot.



ELECTRIC AND MAGNETIC FIELDS may be dangerous

8.a. Electric current flowing through any conductor causes localized Electric and Magnetic Fields (EMF). Welding current creates EMF fields around welding cables and welding machines.

8.b. EMF fields may interfere with some pacemakers, and welders having a pacemaker should consult their physician before welding.

8.c. Exposure to EMF fields in welding may have other health effects which are now not known.

8.d. All welders should use the following procedures in order to minimize exposure to EMF fields from the welding circuit:

8.d.1. Route the electrode and work cables together - Secure them with tape when possible.

8.d.2. Never coil the electrode lead around your body.

8.d.3. Do not place your body between the electrode and work cables. If the electrode cable is on your right side, the work cable should also be on your right side.

8.d.4. Connect the work cable to the workpiece as close as possible to the area being welded.

8.d.5. Do not work next to welding power source.

PRÉCAUTIONS DE SÛRETÉ

Pour votre propre protection lire et observer toutes les instructions et les précautions de sûreté spécifiques qui paraissent dans ce manuel aussi bien que les précautions de sûreté générales suivantes:

Sûreté Pour Soudage A L'Arc

1. Protégez-vous contre la secousse électrique:
 - a. Les circuits à l'électrode et à la pièce sont sous tension quand la machine à souder est en marche. Éviter toujours tout contact entre les parties sous tension et la peau nue ou les vêtements mouillés. Porter des gants secs et sans trous pour isoler les mains.
 - b. Faire très attention de bien s'isoler de la masse quand on soude dans des endroits humides, ou sur un plancher métallique ou des grilles métalliques, principalement dans les positions assis ou couché pour lesquelles une grande partie du corps peut être en contact avec la masse.
 - c. Maintenir le porte-électrode, la pince de masse, le câble de soudage et la machine à souder en bon et sûr état de fonctionnement.
 - d. Ne jamais plonger le porte-électrode dans l'eau pour le refroidir.
 - e. Ne jamais toucher simultanément les parties sous tension des porte-électrodes connectés à deux machines à souder parce que la tension entre les deux pinces peut être le total de la tension à vide des deux machines.
 - f. Si on utilise la machine à souder comme une source de courant pour soudage semi-automatique, ces précautions pour le porte-électrode s'appliquent aussi au pistolet de soudage.
2. Dans le cas de travail au dessus du niveau du sol, se protéger contre les chutes dans le cas où on recoit un choc. Ne jamais enrouler le câble-électrode autour de n'importe quelle partie du corps.
3. Un coup d'arc peut être plus sévère qu'un coup de soleil, donc:
 - a. Utiliser un bon masque avec un verre filtrant approprié ainsi qu'un verre blanc afin de se protéger les yeux du rayonnement de l'arc et des projections quand on soude ou quand on regarde l'arc.
 - b. Porter des vêtements convenables afin de protéger la peau de soudeur et des aides contre le rayonnement de l'arc.
 - c. Protéger l'autre personnel travaillant à proximité au soudage à l'aide d'écrans appropriés et non-inflammables.
4. Des gouttes de laitier en fusion sont émises de l'arc de soudage. Se protéger avec des vêtements de protection libres de l'huile, tels que les gants en cuir, chemise épaisse, pantalons sans revers, et chaussures montantes.
5. Toujours porter des lunettes de sécurité dans la zone de soudage. Utiliser des lunettes avec écrans latéraux dans les

zones où l'on pique le laitier.

6. Eloigner les matériaux inflammables ou les recouvrir afin de prévenir tout risque d'incendie dû aux étincelles.
7. Quand on ne soude pas, poser la pince à un endroit isolé de la masse. Un court-circuit accidentel peut provoquer un échauffement et un risque d'incendie.
8. S'assurer que la masse est connectée le plus près possible de la zone de travail qu'il est pratique de le faire. Si on place la masse sur la charpente de la construction ou d'autres endroits éloignés de la zone de travail, on augmente le risque de voir passer le courant de soudage par les chaînes de levage, câbles de grue, ou autres circuits. Cela peut provoquer des risques d'incendie ou d'échauffement des chaînes et des câbles jusqu'à ce qu'ils se rompent.
9. Assurer une ventilation suffisante dans la zone de soudage. Ceci est particulièrement important pour le soudage de tôles galvanisées plombées, ou cadmiées ou tout autre métal qui produit des fumées toxiques.
10. Ne pas souder en présence de vapeurs de chlore provenant d'opérations de dégraissage, nettoyage ou pistolage. La chaleur ou les rayons de l'arc peuvent réagir avec les vapeurs du solvant pour produire du phosgène (gas fortement toxique) ou autres produits irritants.
11. Pour obtenir de plus amples renseignements sur la sûreté, voir le code "Code for safety in welding and cutting" CSA Standard W 117.2-1974.

PRÉCAUTIONS DE SÛRETÉ POUR LES MACHINES À SOUDER À TRANSFORMATEUR ET À REDRESSEUR

1. Relier à la terre le chassis du poste conformément au code de l'électricité et aux recommandations du fabricant. Le dispositif de montage ou la pièce à souder doit être branché à une bonne mise à la terre.
2. Autant que possible, l'installation et l'entretien du poste seront effectués par un électricien qualifié.
3. Avant de faire des travaux à l'intérieur de poste, la débrancher à l'interrupteur à la boîte de fusibles.
4. Garder tous les couvercles et dispositifs de sûreté à leur place.

TABLE OF CONTENTS

	Page
Safety Precautions	2-4
Introductory Information	6
Product Description.....	7
Recommended Processes and Equipment.....	7
Optional Accessories	7
Specifications.....	8
Installation	8-12
Safety Precautions	8
Unpacking the SP-100.....	8
Description of Controls	9
Location of Equipment.....	9
Work Cable and Clamp	9
Output Polarity Connection.....	10
Gun.....	10
Wire Feed Drive Roll	10
Welding Wire Loading	10
Electrical Input Connection.....	11
Shielding Gas Connection.....	12
Optional Accessories.....	12
Operating Instructions.....	13
Safety Precautions	13
Duty Cycle	13
Selecting a Wire Spool Size	13
Feeding Welding Wire	13
Making a Weld.....	14
Overload Protection Shutdown	14
Wire Feed Overload Protection	14
Learning to Weld.....	15
The Arc-Welding Circuit.....	15
The Self-Shielded FCAW Welding Arc.....	15
Machine Setup for the Self-Shielded FCAW Process	16
Welding Techniques for the Self-Shielded FCAW Process.....	16
Common Metals	17
Types of Welds.....	18
Welding Procedures	18
Welding in the Vertical Position	18
The GMAW (MIG) Welding Arc	19
Process Selection.....	19
Machine Setup for the GMAW (MIG) Process.....	20
Welding Techniques for GMAW (MIG) Process	20
Welding Procedures	20
Troubleshooting Welds.....	21
Proper Gun Handling.....	21
Routine Maintenance	22 - 23
Troubleshooting Guide	24 - 25
Wiring Diagram	26
Procedures Chart.....	27
Parts Lists.....	28 - 39
Book Order Form	41
Nine Language Warning Information.....	42 - 43
Waranty Information	Back Cover

Thank You

for selecting a **QUALITY** product by Lincoln Electric. We want you to take pride in operating this Lincoln Electric Company product ••• as much pride as we have in bringing this product to you!

Please Examine Carton and Equipment For Damage Immediately

When this equipment is shipped, title passes to the purchaser upon receipt by the carrier. Consequently, Claims for material damaged in shipment must be made by the purchaser against the transportation company at the time the shipment is received.

Please record your equipment identification information below for future reference. This information can be found on your machine nameplate.

Model Number _____

Serial or Product Number _____

Date of Purchase _____

Whenever you request replacement parts for or information on this equipment always supply the information you have recorded above.

Read this Operators Manual completely before attempting to use this equipment. Save this manual and keep it handy for quick reference. Pay particular attention to the safety instructions we have provided for your protection. The level of seriousness to be applied to each is explained below:

WARNING

This statement appears where the information **must** be followed **exactly** to avoid **serious personal injury** or **loss of life**.

CAUTION

This statement appears where the information **must** be followed to avoid **minor personal injury** or **damage to this equipment**.

EXPLANATION OF SYMBOLS THAT APPEAR ON THIS EQUIPMENT



OFF



ARC VOLTS



ON



WIRE SPEED

PRODUCT DESCRIPTION

The SP-100, Type K462, is a complete semiautomatic constant voltage DC arc welding machine. Included is a solid state controlled, single phase constant voltage transformer/ rectifier power source and a wire feeder for feeding .023 – .030" (0.6 – 0.8 mm) solid steel electrode and .035" (0.9 mm) cored electrode.

The SP-100 is ideally suited for individuals having access to 115 volt AC input power, and wanting the ease of use, quality and dependability of both gas metal arc welding or GMAW (also known as MIG welding) and the Innershield® electrode process (self-shielded flux-cored or FCAW). A convenient chart is mounted inside the wire feed section door for setting welding procedures for 24 gauge through 12 gauge (0.6 – 2.5 mm) mild steel (Chart also may be found in this manual). The SP-100 is a rugged and reliable machine that has been designed for dependable service and long life.

RECOMMENDED PROCESSES AND EQUIPMENT

The SP-100 can be used for welding mild steel using the GMAW, single pass, process which requires a supply of shielding gas or it can be used for the self-shielded, Innershield electrode process.

The recommended gas and electrode for GMAW is welding grade CO₂ gas and .025" (0.6 mm) diameter Lincoln L-56 mild-steel welding wire [supplied on 12 1/2 lb (6 kg) spools]. For 14 gauge (2.0 mm) and thinner, CO₂ gas is recommended because it gives equal or better performance than a blended gas at a lower cost. A mixed gas consisting of 75 to 80% Argon and 20 to 25% CO₂ is recommended for welding on heavier gauge [12 gauge (2.5 mm) for example] steel.

The recommended electrode for the self-shielded process is .035" (0.9 mm) diameter Lincoln Innershield NR-211-MP on 10 lb (4.5 kg) spools. This electrode can be used for all position welding of 20 gauge through 5/16" (1.0 – 8.0 mm) thick steel [multiple passes are required for 1/4" and 5/16" (6.0 and 8.0 mm)].

WARNING

Use of the GMAW process with the SP-100 on thicker materials than recommended may result in poor welds. The welds may "look" good, but may just be "sitting" on top of the plate. This is called "cold casting" and will result in weld failure.

Comparison of the GMAW (MIG) and FCAW (Innershield) Processes

Electrode Wire	.025" (0.6 mm) Dia. L-56 (GMAW)	.035" (0.9 mm) Dia. NR-211-MP Innershield (FCAW)
Shielding Gas	CO ₂ or blended	None (Self Shielded)
Electrode Polarity	Positive	Negative
Minimum Gauge	24 ga (0.6 mm)	20 ga (1.0 mm) NOTE: Requires more skill to use on 20 and 18 gauge (1.0 and 1.2 mm) than is required with .025" (0.6 mm) L-56.
Maximum Gauge	14 gauge (2.0 mm) NOTE: Can be used for 12 gauge (2.5 mm) with Argon-CO ₂ gas. ⁽¹⁾	Can be used to weld 1/4" and 5/16" (6.3 mm and 8.0 mm) thick steel with multiple passes.
Penetration into Base Metal	Good	Excellent
Smoke Level	Low	High
Amount of Slag	Low, little or no cleaning required	Slag must be removed

OPTIONAL ACCESSORIES

- K463 CO₂ Gas Regulator and Hose Kit** — Includes a preset, nonadjustable pressure and flow regulator for use on CO₂ cylinders. Also included is a 10 foot (3.0 m) gas hose which connects to the rear of the SP-100.
- K499 Ar-Mixed Gas Regulator and Hose Kit** — Includes a preset, nonadjustable pressure and flow regulator for use on argon-mixed gas cylinders. Also included is a 10 foot (3.0 m) gas hose which connects to the rear of the SP-100.
- .035 (0.9 mm) Innershield® Welding Kit** — Includes a contact tip, a gasless nozzle and a cable liner to permit the SP-100 gun and cable to use a .035" (0.9 mm) diameter flux-cored elec-

trode. Also included is a spool of .035 (0.9 mm) Innershield® NR-211-MP.

Two kits are available:

K549-1 kit is for use with the Magnum™ 100L gun (with red trigger).

K464 kit is for use with the original Lincoln Electric® gun (with black trigger).

- M15448-1 Reversible Drive Roll** with double knurled grooves for .035 cored electrode.
- K467 Input Line Cord** — Same as line cord supplied with the SP-100 but has a NEMA type 5-20P plug for use on 25 amp branch circuits.

To install optional features refer to instructions included with the kit, and/or in this manual.

SPECIFICATIONS

Type	K462
Rated DC Output (For use on 20 ampere branch circuit)	90 amps @ 18 volts 20% duty cycle
Maximum DC Output (For use on 25 ampere branch circuit with optional K467 input line cord installed)	100 amps @ 17 volts 30% duty cycle
CSA Rated DC Output (For use on 15 ampere branch circuit)	63 amps @ 20 volts 20% duty cycle
Input Power @ CSA rated Output AC only	115 volts 60 hertz 15 amps
Maximum Open Circuit Voltage	28 volts
Input Power @ Rated Output, AC only	115 volts 60 hertz 20 amps
Input Power @ Maximum Output, AC only	115 volts 60 hertz 25 amps
Wire Speed Range	50 to 400 in./min (1.3 to 10.2 m/min)
Wire Sizes	.023 – .030" (0.6 – 0.8 mm) Solid Steel .035" (0.9 mm) Flux-Cored ⁽¹⁾
Spool Sizes	8" OD x 2" ID x 2.2" wide (200 mm x 50 mm x 56 mm) 4" OD x 5/8" ID x 1.7" wide (100 mm x 16 mm x 43 mm)
Weight	54 lbs (24.3 kg)
Dimensions (H x W x D) (Less Handle)	12" x 9 3/4" x 16 1/2" (305 mm x 248 mm x 419 mm)

¹⁾Requires optional Innershield Welding Kit

INSTALLATION

SAFETY PRECAUTIONS

- Read the safety precautions at the beginning of this Operator's Manual before proceeding.
- Only personnel that have read and understood the SP-100 Operating Manual should install and operate this equipment.
- Machine must be plugged into a receptacle which is grounded per any national, local or other applicable electrical codes.
- The SP-100 power switch is to be in the OFF ("O") position when installing work cable and gun and when connecting power cord to input power.

UNPACKING THE SP-100 (K462)

Unpack the SP-100 from its carton and remove all packing material around the SP-100. Remove the following loose items from the carton:

- 1.SP-100.
- 2.Gun and cable assembly⁽¹⁾ — ready to feed .025" (0.6 mm) diameter wire (also .023 and .024 diameter wire).
- 3.Literature envelope which contains:
 - a) This operating manual, and
 - b) A contact tip for .030" (0.8 mm) diameter wire.
- 4.10 ft (3.0 m) work cable.
- 5.Work clamp.

⁽¹⁾ K474 model gun is ready to feed .035 (0.9 mm) Innershield with conversion parts for .030 (0.8) wire.

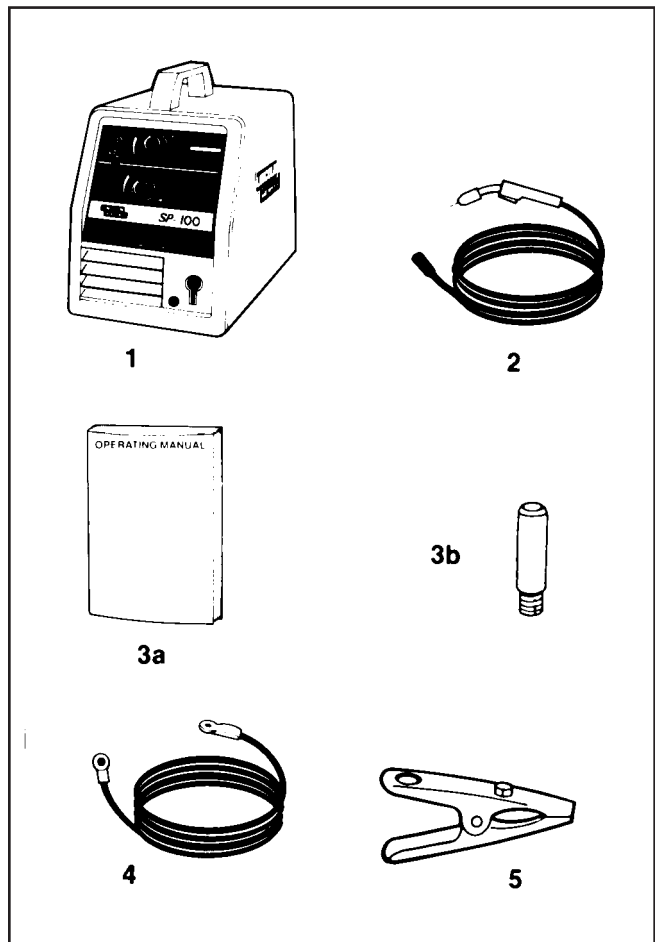

DESCRIPTION OF CONTROLS

Become familiar with the SP-100 controls and components before attempting to weld. Refer to illustrations and lettered items below for brief descriptions.

- A. Wire speed — Controls the wire speed from 50 – 400 in./min (1.3 – 10 m/min). The control can be preset on the dial to the setting specified on the SP-100 Application Chart located on the inside of the wire feed section door. Wire speed is not affected when changes are made in the voltage control. The control is marked (“olo”)
- B. Power ON/OFF switch — When the power is on, the fan motor will run and air will be exhausted out the louvers in the front of the machine. The welding output and wire feeder remain off until the gun trigger is pressed.
- C. Voltage control — A continuous control that gives full range adjustment of power source output voltage. Can be adjusted while welding.
- D. Thumbscrew — secures gun and cable assembly.
- E. Positive (+) and negative (–) output terminals.
- F. Shielding gas hose (factory installed, not shown) — routed from gas solenoid inside rear of machine to gun connector block.
- G. Gun trigger lead connectors.
- H. Circuit breaker — Protects machine from damage if maximum output is exceeded. Button will extend out when tripped. (Manual reset.)
- I. Wire spool spindle.
- J. Gas solenoid inlet fitting.
- K. Power cord.
- L. Spring loaded pressure arm — adjusts pressure of idle roll on wire.

- M. Wire feed gearbox and gun connector block.
- N. Wire feed section door — With application chart for machine setting procedures.
- O. Gun cable and control lead access hole.
- P. Work cable access hole.

LOCATION

Locate the welder in a dry location where there is free circulation of clean air into the louvers in the back and out the front. A location that minimizes the amount of smoke and dirt drawn into the rear louvers reduces the chance of dirt accumulation that can block air passages and cause overheating.

WORK CABLE AND CLAMP INSTALLATION

Work Clamp Installation

Attach the work clamp to the work cable per the following:

1. Unplug the machine or turn the power switch to the “Off” position.
2. Insert the work cable terminal lug with the larger hole through the strain relief hole in the work clamp as shown below.
3. Fasten securely with the bolt and nut provided.

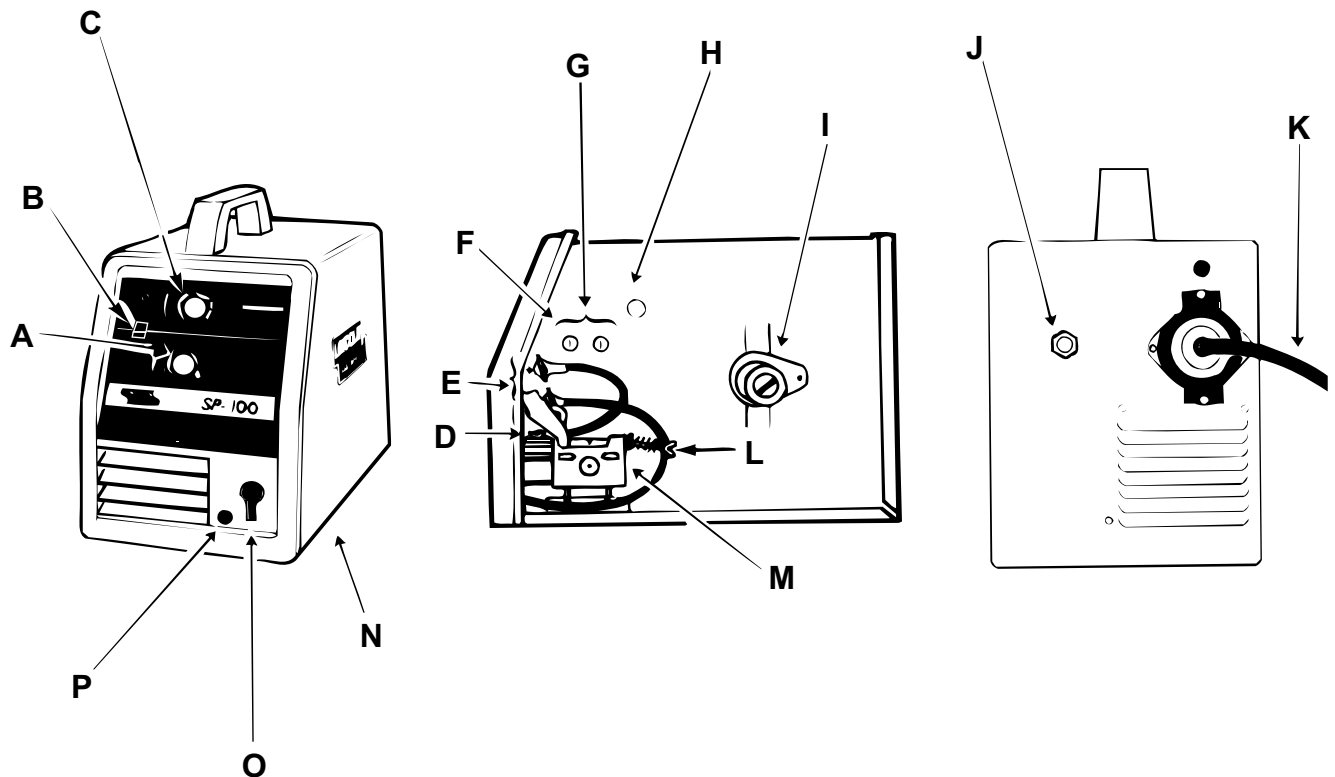
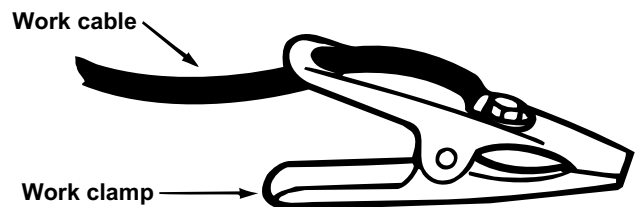

Work Cable Installation

1. Open the wire feed section door on the right side of the SP-100.
2. Pass the end of the work cable that has the terminal lug with the smaller hole through the hole (hole D) next to the louvers in the case front.
3. Route the cable under and around the back of the wire feed unit.
4. Using wing nut provided, connect the terminal lug to the negative (-) output terminal located above the wire feed unit; item M (make certain that **both** wing nuts are tight).

NOTE: This connection gives the correct electrode polarity for the GMAW process. If using Innershield, see Output Polarity Connection Section below for negative electrode polarity connection.

OUTPUT POLARITY CONNECTION

The SP-100, as shipped, is connected for positive electrode polarity.

To connect for negative electrode polarity (required for the Innershield process), connect the short cable attached to the gun connector block to the negative (-) output terminal and the work cable to the positive (+) terminal using the provided wing nuts (make certain that **both** wing nuts are **tight**).

GUN INSTALLATION

As shipped from the factory, the SP-100 gun is ready to feed .023, .024 or .025" (0.6 mm) wire. If .030" (0.8 mm) wire is to be used, install the .030" (0.8 mm) contact tip. .023 – .025" contact tip is stenciled .025 and/or 0.6 mm and .030" contact tip is stenciled .030 and/or 0.8 mm. See Maintenance Section for instructions to change contact tip.

If .035" (0.9 mm) Innershield flux cored wire is to be used, see Maintenance Section for instructions to change contact tip, cable liner, and gas nozzle.

Connect the gun cable to the SP-100 per the following:

1. Unplug the machine or turn power switch to the off "O" position.
2. Pass the insulated terminals of the gun trigger control leads, one at a time, through the rectangular "keyhole" opening (item F) in the case front. The leads are to be routed under the wire feed unit and through the cable hanger on the inner panel.
3. Insert the connector on the gun conductor cable through the large hole in the SP-100 case front. Make sure the connector is all the way in the metal connector block to obtain proper gas flow. Rotate the connector so control leads are on the underside and tighten the thumbscrew in the connector block.
4. Connect the insulated control lead terminals to the two insulated 1/4" (6.4 mm) tab connector bushings located above the "Gun Trigger Connection" decal in the wire feed section. Either lead can go to either connector. Form the leads so that they are as close as possible to the inside panel.

CAUTION

The gun trigger switch must be a normally open, momentary switch. The terminals of the switch must be insulated from the welding circuit. Malfunction of the SP-100 will result if this switch shorts to the SP-100 welding output circuit or is common to any electrical circuit other than the SP-100 trigger circuit.

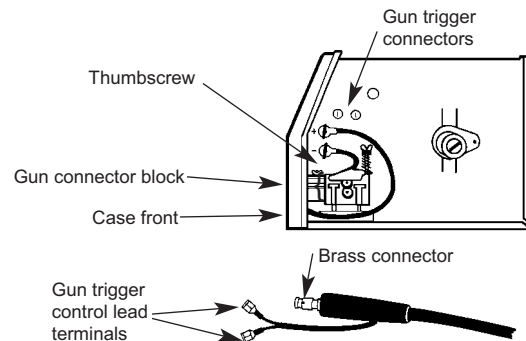

WIRE FEED DRIVE ROLL

The SP-100 drive roll has two grooves; one for .023 – .025" (0.6 mm) solid steel electrode and the other for .030" (0.8 mm) solid and .035" (0.9 mm) flux-cored steel electrode. As shipped, the drive roll is installed in the .023/.025" (0.6 mm) position (as indicated by the stenciling on the exposed side of the drive roll).

If .030 – .035" (0.8 – 0.9 mm) wire is to be used, the drive roll must be reversed as follows:

1. Make certain the SP-100 power switch is "off".
2. Open the quick release arm; lift up the idle roll arm.
3. Remove the drive roll retaining screw and washer with a screwdriver.
4. Remove the drive roll, flip over and install with the .030/.035" (0.8/0.9 mm) stencil visible (away from gearbox). Make certain the small key is in place in the keyway.
5. Replace the washer and retaining screw.

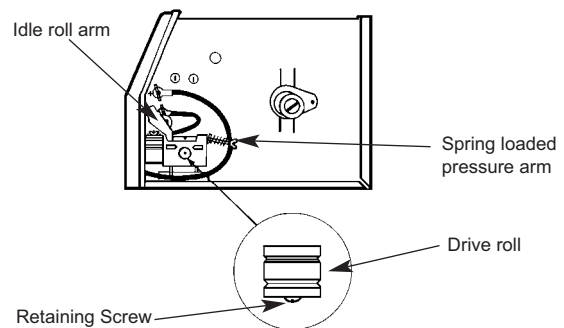

WELDING WIRE LOADING

WARNING

The machine power switch should be turned to the OFF ("O") position before working inside the wirefeed enclosure.

The machine is shipped from the factory ready to feed 8" (200 mm) diameter spools [2.2" (56 mm) max. width]. These spools fit on a 2" (50 mm) diameter spindle that has a built-in, adjustable* friction brake to prevent overrun of the spool and excess slack in the

wire. The thumb screw at the end of the shaft is not intended to be loosened; it should be tightened full clockwise.

*Earlier spindle shafts did not include a set screw to adjust brake friction. If set screw is desired, order Lincoln part number T12932-2.

⚠ CAUTION

If full tightening of the spindle thumbscrew causes too much feed force to rotate the wire spool, the thumbscrew stop point can be adjusted as follows:

A. Remove the thumbscrew.

B. Using a 3/16" (4.8mm) hex wrench, turn the set screw, located inside the tapped hole in the spindle shaft, one or two turns counterclockwise.

C. Fully reinstall the thumbscrew and check for proper brake force to prevent spool overrun, but allow smooth and easy wire feeding. If not, repeat.

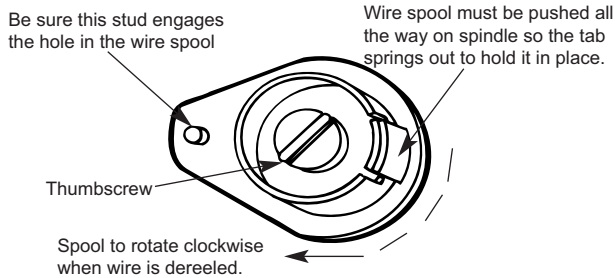

Load an 8" (200 mm) diameter spool on the wire spool spindle shown above.

To use 4" (100 mm) diameter spools, the 2" (50 mm) diameter spindle must be removed. Remove the thumb screw at the end of the shaft and remove the spindle. It can be stored in the wire feed compartment. A 4" (100 mm) diameter spool is mounted directly on the 5/8" (16 mm) diameter shaft and held in place with the previously removed thumb screw. Make certain that the thumbscrew is tightened fully clockwise. Also make certain the start end of the wire which may protrude through the side of the spool does not contact any metallic case parts.

Thread the welding wire through the wire feeder guide tubes per the following instructions:

1. Release the idle roll pressure arm and rotate the idle roll arm away from the drive roll. (Check that visible, stenciled size on drive roll matches wire size being used — See Wire Drive Roll Section.)
2. Carefully detach the end of the wire from the spool. To prevent the spool from unwinding, do **not** release the wire until after step 5.
3. Cut the bent portion of wire off and straighten the first 4" (100 mm).
4. Thread the wire through the ingoing guide tube, over the drive roll, and into the outgoing guide tube.
5. Close the idle roll arm and latch the pressure arm in place (now you may release the welding wire).
6. The idle roll pressure adjustment wing nut is normally set for mid-position on the pressure arm threads. If feeding problems occur because the wire is flattened excessively, turn the pressure adjustment counterclockwise to reduce distortion of the wire. Slightly less pressure may be required when using .023-.025 (0.6 mm) wire. If the drive roll slips while feeding wire, the pressure should be increased until the wire feeds properly. NOTE: See operating instructions for feeding welding wire on page 12.

ELECTRICAL INPUT CONNECTION

⚠ WARNING



ELECTRIC SHOCK can kill.

- Disconnect input power by removing plug from receptacle before working inside SP-100.
- Use only grounded receptacle.
- Do not remove the power cord ground prong.
- Do not touch electrically "hot" parts inside SP-100.
- Have qualified personnel do the maintenance and troubleshooting work.

Code Requirements

⚠ WARNING

This welding machine must be connected to power source in accordance with applicable electrical codes.

The United States National Electrical Code (Article 630-B, 1990 Edition) provides standards for ampere handling capability of supply conductors based on duty cycle of the welding power source.

If there is any question about the installation meeting applicable electrical code requirements, consult a qualified electrician.

Requirements for Rated Output

A power cord with a 15 amp, 125 volt, three prong plug (NEMA Type 5-15P) is factory installed on the SP-100. Connect this plug to a mating **grounded** receptacle which is connected to a 20 amp branch circuit with a nominal voltage rating of 115 to 125 volts, 60 Hertz, AC only.

The rated output with this installation is 90 amps, 18 volts, 20% duty cycle (2 minutes of every 10 minutes used for welding).

⚠ CAUTION

Do not connect the SP-100 to an input power supply with a rated voltage that is greater than 125 volts.

Requirements for Maximum Output

An optional power cord is available to permit the SP-100 to be connected to a 25 amp branch circuit with a nominal voltage rating of 115 to 125 volts, 60 Hertz, AC only. With this installation the SP-100 can be used at an output of 100 amps, 17 volts, 30% duty cycle. See Optional Accessories Section.

Requirements for CSA Rated Output

A line cord with a 15 amp, 125 volt, three-prong plug (NEMA Type 5-15P) is factory installed. Connect this plug to a mating grounded receptacle which is connected to a 15 amp branch circuit with a nominal voltage rating of 115 volts to 125 volts, 60 hertz, AC only. With this installation, the SP-100 can be used at an output of 63 amps, 20 volts, 20% duty cycle.

Extension Cord

If an extension cord is required, use one that is rated for the application and is 3 conductor #14 AWG (2.1 mm²) or larger. The recommended maximum lengths are 25 ft (7.5 m) if #14 AWG (2.1 mm²) is used and 50 ft (15 m) if #12 AWG* (3.3 mm²) is used.

*AMERICAN WIRE GAUGE

SHIELDING GAS

When using the GMAW process, a cylinder of carbon dioxide (CO₂) or argon-carbon dioxide mixed shielding gas, flow regulator, and an inlet gas hose must be obtained.

The Lincoln K463 CO₂ or K499 Ar-mixed gas regulator and hose kit is recommended for use with the SP-100.

Weld shielding gas may be obtained from a welding supply distributor.

⚠ WARNING

CYLINDER may explode if damaged.



- Keep cylinder upright and chained to support.
- Keep cylinder away from areas where it may be damaged.

- Never lift welder with cylinder attached.
- Never allow welding electrode to touch cylinder.
- Keep cylinder away from welding or other live electrical circuits.

BUILDUP OF SHIELDING GAS may harm health or kill.



- Shut off shielding gas supply when not in use.

SEE AMERICAN NATIONAL STANDARD Z-49.1, "SAFETY IN WELDING AND CUTTING" PUBLISHED BY THE AMERICAN WELDING SOCIETY.

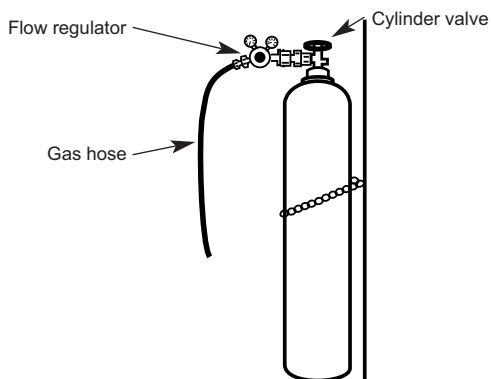

1. Chain the cylinder to a wall or other stationary support to prevent the cylinder from falling over. Insulate the cylinder from the work circuit and earth ground.
2. With the cylinder securely installed, remove the cylinder cap. Stand to one side away from the outlet and open the cylinder valve **very slightly for an instant**. This blows away any dust or dirt which may have accumulated in the valve outlet.

⚠ WARNING

BE SURE TO KEEP YOUR FACE AWAY FROM THE VALVE OUTLET WHEN "CRACKING" THE VALVE. Never stand directly in front of or behind the flow regulator when opening the cylinder valve. Always stand to one side.

3. Attach the flow regulator to the cylinder valve and tighten the union nut securely with a wrench. Flow regulator for carbon dioxide **must** have plastic washer seated in the fitting that attaches to the cylinder.
4. Attach one end of inlet gas hose to the outlet fitting of the flow regulator and tighten the union nut securely with a wrench. Connect the other end to the SP-100 inlet gas fitting (5/8 – 18 female threads — for CGA – 032 fitting). Make certain the gas hose is not kinked or twisted.
5. For CO₂, open the cylinder valve slowly. For argon-mixed gas, open cylinder valve slowly a fraction of a turn. When the cylinder pressure gauge pointer stops moving, open the valve fully.
6. If using a regulator with an adjustable flowmeter, close the gun trigger and adjust the flow to give 15 – 20 cubic ft per hour (CFH) (7 – 10 L/min) [use 20 – 25 CFH (10 – 12 L/min) when welding out of position or in a drafty location for CO₂]. For argon mixed gas, adjust the flow to give 25-30 CFH (12-14 L/min).
7. Keep the cylinder valve closed, except when using the SP-100. When finished welding:
 - a) First close the cylinder valve to stop gas flow,
 - b) then depress the gun trigger briefly to release the pressure in the gas hose.
 - c) turn off the SP-100.

OPTIONAL ACCESSORIES INSTALLATION

K463 CO₂ Gas Regulator and Hose Kit

Install the pressure-flow regulator to a cylinder according to the instructions in Section 1.10. Make certain the plastic washer is seated in the fitting that attaches to the CO₂ cylinder. Connect one end of the 10 foot (3.0 m) hose to the SP-100 gas inlet fitting and the other end to the regulator outlet fitting.

The K463 CO₂ pressure-flow regulator is preset at the factory to give a flow rate of 20 cubic feet per hour (10 l/min). This setting cannot be changed.

The K463 CO₂ pressure-flow regulator can be used on a cylinder of argon-mixed gas if a CGA-580-320 (Western Enterprises No. 810) adapter is used between the cylinder and the regulator.

K499 Argon-Mixed Gas Regulator and Hose Kit

Install the pressure-flow regulator and gauge to a cylinder according to the instructions in Section 1.10. Connect one end of the 10 foot (3.0 m) hose to the SP-100 gas inlet fitting and the other end to the regulator fitting.

The K499 argon-mixed gas pressure-flow regulator is preset by the manufacturer to deliver a nominal flow of 30 cubic feet per hour (14 l/min) of argon or argon-mixed gas. This setting cannot be changed.

.035" (0.9 mm) Innershield Welding Kit

Includes a contact tip, gasless nozzle, and a cable liner to permit the SP-100 gun and cable to use .035 (0.9 mm) diameter flux-cored electrode. Also included is a spool of .035 (0.9 mm) Innershield® NR-211-MP.

The **K549-1 Kit** is for use with the Magnum™ 100L gun (with red trigger). The fitting on the end of the liner is stenciled with the maximum rated wire size (.045"/1.2 mm).

The **K464 Kit** is for use with the earlier "Lincoln Electric®" gun (with black trigger). The end of the brass fitting on the end of the liner for .035 (0.9 mm) wire is color coded green. The .023-.030 (0.6-0.8 mm) factory installed liner is color coded orange.

See Maintenance and Troubleshooting Section for instructions on installing liner and contact tip in gun.

K467 Input Line Cord

Same as line cord supplied with the SP-100 but has a NEMA type 5-20P plug for use on a 25 amp branch circuit with a nominal voltage rating of 115 volts to 125 volts, 60 hertz. Install per the following:

1. Turn the SP-100 Power Switch to OFF ("O").
2. If connected, remove the line cord plug from power supply receptacle.
3. Remove the two screws that hold the line cord receptacle in the SP-100 flanged inlet connector and disconnect the line cord from the SP-100.
4. Connect the S18410 input line cord receptacle to the SP-100 and replace the retaining screws.

OPERATING INSTRUCTIONS

⚠ WARNING



ELECTRIC SHOCK can kill.

- Do not touch electrically live parts or electrode with skin or wet clothing.
- Insulate yourself from work and ground.
- Always wear dry insulating gloves.



FUMES AND GASES can be dangerous.

- Keep your head out of fumes.
- Use ventilation or exhaust to remove fumes from breathing zone.

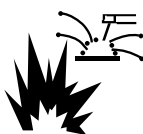

WELDING SPARKS can cause fire or explosion.

- Keep flammable material away.
- Do not weld on closed containers.



ARC RAYS can burn eyes and skin.

- Wear eye, ear and body protection.

See additional warning information at front of this owners manual.

DUTY CYCLE

The SP-100 is rated at the following duty cycles.

Condition	Duty Cycle ⁽¹⁾	Amps	Volts
Rated Output	20%	90	18
Maximum Output ⁽²⁾	30%	100	17
CSA Rated Output	20%	63	20

⁽¹⁾ Based upon 10 minute time period. (i.e. for 20% duty cycle it is 2 minutes on and 8 minutes off.)

⁽²⁾ Using Optional K467 Input line cord on a 25 amp branch circuit.

SELECTING A WIRE SPOOL SIZE

Select a spool size so that the wire is used up within a six month period. This eliminates needless waste of wire due to oxidation and rusting. Dirty, oxidized, or rusty wire results in poor wire feeding and poor welding performance. This wire should be discarded.

FEEDING WELDING WIRE

⚠ WARNING

When inching the welding wire, the drive rolls, the gun connector block and the gun contact tip are always energized relative to work and ground and remain energized several seconds after the gun trigger is released.

1. Remove gas nozzle and contact tip from end of gun according to instructions in the maintenance section of this manual.
2. Turn the SP-100 ON ("I").
3. Straighten the gun cable assembly.

4. Depress the gun trigger switch and feed welding wire through the gun and cable (Point gun away from yourself and others while feeding wire.) Release gun trigger after wire appears at end of gun.
5. Replace contact tip and gas nozzle.
6. Cut the wire off 1/4 – 3/8" (6 – 10 mm) from the end of the tip. The SP-100 is now ready to weld.

Making A Weld

1. See "Recommended Processes and Equipment" section for selection of welding wire and shielding gas and for range of metal thicknesses that can be welded.
2. See the Applications chart on the inside of wire feed section door for information on setting the SP-100 controls.
3. Set the Voltage ("V") and Wire Speed ("olo") controls to the settings suggested for the welding wire and base metal thickness being used.
4. Check that the polarity is correct for the welding wire being used and that the gas supply, if required, is turned on.
5. When using Innershield® electrode, remove the gas nozzle and install the gasless nozzle. This will improve visibility of the arc and protect the gas diffuser from weld spatter.
6. Connect work clamp to metal to be welded. Work clamp must make good electrical contact to the workpiece. The workpiece must also be grounded as stated in "Arc Welding Safety Precautions".
7. Position gun over joint. End of wire may be lightly touching the work.
8. Lower welding helmet, close gun trigger, and begin welding. Hold the gun so the contact tip to work distance is about 3/8 inch (10 mm).
9. To stop welding, release the gun trigger and then pull the gun away from the work after the arc goes out.
10. When no more welding is to be done, close valve on gas cylinder (if used), momentarily operate gun trigger to release gas pressure, and turn off SP-100.

OVERLOAD PROTECTION SHUTDOWN

Welding Power Overload Protection

CAUTION

Exceeding the maximum rating of the SP-100 can reduce the life of the machine.

The SP-100 has both a thermostat and a circuit breaker to protect the machine from damage if the maximum output is exceeded. If either device is tripped, there will be no wire feed or output voltage when the gun trigger is depressed. (The fan will continue to run.)

If the machine shuts down due to an output overload, first check the circuit breaker which is located on the inside panel of the wire feed section. If the button is extended, reset after several minutes of cooling, by depressing the button.

If there is no output and the circuit breaker is not tripped, the internal thermostat has probably tripped. This device will automatically reset after several minutes of cooling. Leaving the machine on with the fan motor running will cool the machine at a faster rate, allowing the thermostat to reset sooner.

If the SP-100 does not operate and the fan does not run with the machine **ON** ("I"), the power supply branch circuit protection (circuit breaker or fuse) has tripped.

Wire Feed Overload Protection

The SP-100 has an automatic electronic protection circuit to protect the wire feed motor. If excessive motor overload occurs (due to prolonged excessive feeding force, jammed drive rolls or shorted motor leads), the circuit will shutdown the wire feed motor and the welding power output.

The wire feed shutdown will reset automatically when the gun trigger is released, but will reoccur if the overload situation is not corrected. The two most common causes of wire feed overload are an excessively bent gun cable and a plugged contact tip. (See Maintenance and Troubleshooting Section.)

The serviceability of a product or structure utilizing this type of information is and must be the sole responsibility of the builder/user. Many variables beyond the control of The Lincoln Electric Company affect the results obtained in applying this type of information. These variables include, but are not limited to, welding procedure, plate chemistry and temperature, weldment design, fabrication methods and service requirements.

LEARNING TO WELD

No one can learn to weld simply by reading about it. Skill comes only with practice. The following pages will help the inexperienced operator to understand welding and develop this skill. For more detailed information, order a copy of "New Lessons in Arc Welding" listed inside the back cover of this manual.

THE ARC-WELDING CIRCUIT

The operator's knowledge of arc welding must go beyond the arc itself. The operator must know how to control the arc, and this requires a knowledge of the welding circuit and the equipment that provides the electric current used in the arc. Following is a drawing of the welding circuit for the SP-100. The circuit begins where the gun cable is attached to the welding machine. Current flows through the gun cable, gun, and contact tip, to the wire and across the arc. On the work side of the arc, current flows through the base metal to the work cable and back to the welding machine. This circuit must be complete for the current to flow.

The SP-100 welding circuit has a voltage output of 28 volts **DC** maximum. This voltage is quite low and is only present when the gun trigger is depressed.

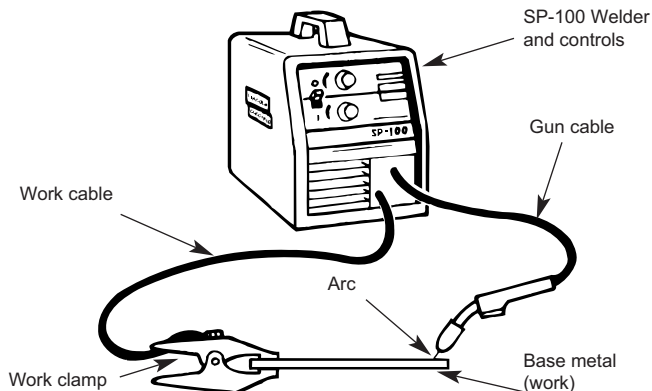

To weld, the work clamp must be **tightly** connected to **clean** base metal. Remove paint, rust, dirt or oil as necessary and connect the work clamp as **close** as possible to the area you wish to weld. This helps prevent current from going through an unwanted path. Avoid allowing the welding circuit to pass through hinges, bearings, electronic components, or similar devices that can be damaged. Always disconnect electrical devices before welding upon them.

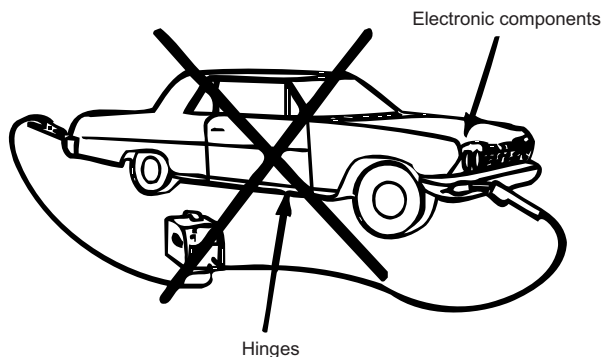

WARNING

Fume and slag generated from Innershield type electrodes recommended for use with this welding machine can be toxic.

- Avoid contact with eyes and skin.
- Do not take internally.
- Keep out of reach of children.
- Follow all safety precautions found in this operating manual.

FIRST AID: If contact in eyes, flush immediately with clean water for at least 15 minutes. If swallowed, induce vomiting. Never give anything by mouth to an unconscious person. Call a physician.

The gun and cable assembly is held by the operator who guides the automatically fed wire along the joint, maintaining a contact tip to work distance of about 3/8 to 1/2 inch (10 – 12 mm) (this is called electrical stick-out). This electrical stickout (ESO) must be properly maintained by the operator. The electric arc is made in the gap between the work and the tip end of a small diameter wire. When the power source is properly set, the arc gap is maintained automatically.

Arc welding is a manual skill requiring a steady hand, good physical condition, and good eyesight. The operator controls the welding arc, and, therefore, the quality of the weld made.

THE SELF-SHIELDED FCAW WELDING ARC

The following drawing illustrates the action taking place in the self-shielded FCAW (Innershield) welding arc. It closely resembles what is actually seen while welding.

The "arc stream" is seen in the middle of the picture. This is the electric arc created by the electric current flowing through the space between the end of the wire electrode and the base metal. The temperature of this arc is about 6000°F, which is more than enough to melt metal. The arc is very bright, as well as hot, and cannot be looked at with the naked eye without risking painful injury. **The very dark lens, specifically designed for arc welding, must be used with the hand or face shield whenever viewing the arc.**

The arc melts the base metal and actually digs into it, much as water through a nozzle on a garden hose digs into the earth. The molten metal forms a molten pool or crater and tends to flow away from the arc. As it moves away from the arc, it cools and solidifies.

The function of the Innershield cored wire electrode is much more than simply to carry current to the arc. The wire core is composed of fluxes and/or alloying ingredients around which a steel sheath has been formed. It is simply a stick electrode turned inside out in a continuous wire form.

WELDING TECHNIQUES FOR THE SELF-SHIELDED FCAW PROCESS

Four simple manipulations are of prime importance. With complete mastery of the four, welding will be easy.

The Correct Welding Position.

Illustrated below is the correct welding position for right-handed people. (For left-handed, it is opposite.)

Hold the gun (of the gun and cable assembly) in your right hand, and hold the hand shield with your left hand. (Left handers simply do the opposite.)

When using the self-shielded FCAW process, weld from left to right (if you are right handed). This enables you to clearly see what you are doing. (Left handers do the opposite.) Tilt the gun toward the direction of travel holding the electrode at an angle as shown below.

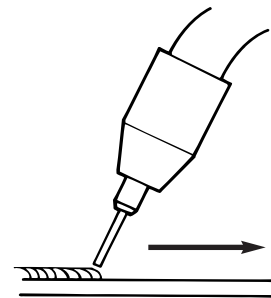

The Correct Way to Strike an Arc.

⚠ WARNING

ARC RAYS can burn eyes and skin.

- When using an open arc process, it is necessary to use correct eye, head and body protection.



- Protect yourself and others; read the section on Arc Burn at the front of this manual.

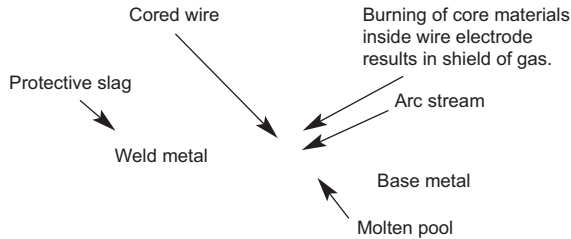

The cored wire melts in the arc and tiny droplets of molten metal shoot across the arc into the molten pool. The wire sheath provides additional filler metal for the joint to fill the groove or gap between the two pieces of the base metal.

The core materials also melt or burn in the arc and perform several functions. They make the arc steadier, provide a shield of smoke-like gas around the arc to keep oxygen and nitrogen in the air away from the molten metal, and provide a flux for the molten pool. The flux picks up impurities and forms the protective slag on top of the weld during cooling.

After running a weld bead, the slag may be removed with a chipping hammer and wire brush. This improves appearance and allows for inspection of the finished weld.

Since machine size and output characteristics limit the size and type of wire electrode which can be used, Lincoln .035" (0.9 mm) NR-211-MP Innershield electrode is recommended for Self-Shielded Flux Cored Arc Welding with the SP-100.

MACHINE SET UP FOR THE SELF-SHIELDED FCAW PROCESS

1. See page 6, "Recommended Processes and Equipment" for selection of welding wire and shielding gas, and for range of metal thicknesses that can be welded.
2. See the "Welding" chart on the inside of wire feed section door for information on setting the controls. (Also on page 23 of this manual.)
3. Set the "Voltage" and "Wire Speed" controls to the settings suggested on the chart for the welding wire and base metal thickness being used. The voltage control is marked "V" and the wire feed speed is marked "OLO."
4. Check that the polarity is correct for the welding wire being used. Set the polarity for DC- when welding with NR-211-MP Innershield electrode. (See installation instructions on page 9 on how to make output polarity connection.)
5. When using Innershield electrode, the gasless nozzle may be used instead of a gas nozzle to give improved visibility.
6. Connect work clamp to metal to be welded. Work clamp must make good electrical contact to the workpiece. The workpiece must also be grounded as stated in "Arc Welding Safety Precautions" section of this manual.

1. Be sure the work clamp makes good electrical contact to the work.
2. Position gun over joint. End of wire may be lightly touching the work.
3. Position faceshield to protect face and eyes, close gun trigger, and begin welding. Hold the gun so that the contact tip to work distance is about 3/8 to 1/2 inch (10 to 12 mm).
4. To stop welding, release the gun trigger and then pull the gun away from the work after the arc goes out.
5. A ball may form at the tip end of the wire after welding. For easier restrikes (with Innershield wire), the ball may be removed by feeding out a few inches of wire and simply bending the wire back and forth until it breaks off.
6. When no more welding is to be done, turn off the machine.

The Correct Electrical Stickout

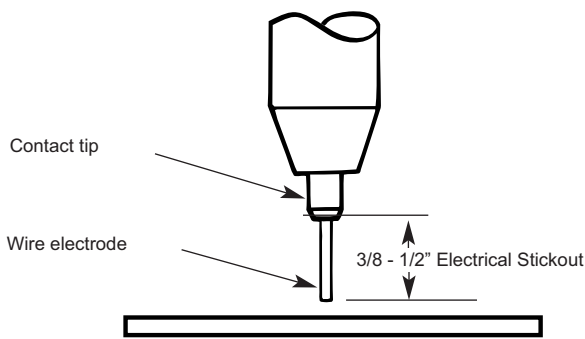

The electrical stickout (ESO) is the distance from the end of the contact tip to the end of the wire.

Once the arc has been established, maintaining the correct ESO becomes extremely important. The ESO should be approximately 3/8 to 1/2 inch (10 to 12 mm) long.

The easiest way to tell whether the ESO is the correct length is by listening to its sound. The correct ESO has a distinctive “crackling” sound, very much like eggs frying in a pan. A long ESO has a hollow, blowing or hissing sound. If the ESO is too short, you may stick the contact tip or nozzle to the weld puddle and/or fuse the wire to the contact tip.

The Correct Welding Speed

The important thing to watch while welding is the puddle of molten metal right behind the arc. Do not watch the arc itself. It is the appearance of the puddle and the ridge where the molten puddle solidifies that indicates correct welding speed. The ridge should be approximately 3/8" (10 mm) behind the wire electrode.

Most beginners tend to weld too fast, resulting in a thin, uneven, “wormy” looking bead. They are not watching the molten metal.

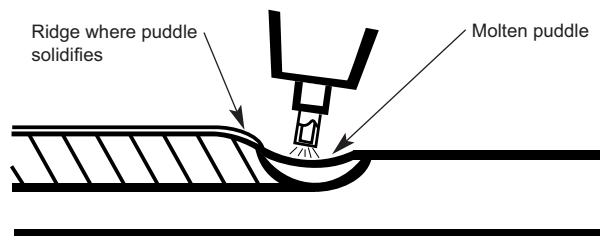

Helpful Hints.

1. For general welding, it is not necessary to weave the arc; neither forward or backward nor sideways. Weld along at a steady pace. You will find it easier.
2. When welding on thin plate, you will find that you will have to increase the welding speed, whereas when welding on heavy plate, it is necessary to go more slowly in order to get good penetration.
3. When welding sheet metal 16 gauge (1.5 mm) and lighter, heat buildup may cause part warpage and burnthrough. One way to eliminate these problems is to use the backstepping method.

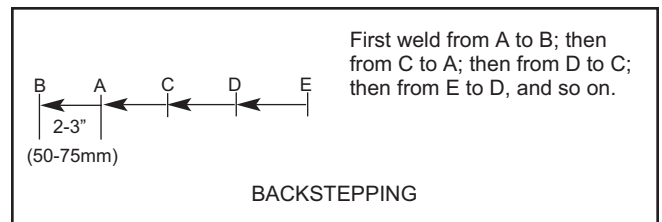

Practice.

The best way of getting practice in the four skills that enable you to maintain:

1. Correct welding position
2. Correct way to strike an arc
3. Correct electrical stickout
4. Correct welding speed

is to spend a little more time on the following exercise.

Use the following:

Mild Steel	16 gauge or 1/16 inch (1.6 mm)
Electrode	.035" (0.9 mm) NR-211-MP Innershield wire
Voltage setting "V"	E
Wire feed speed	010 2

1. Learn to strike an arc by positioning the gun over the joint and touching the wire to the work.
2. Position faceshield to protect face and eyes.
3. Depress gun trigger, hold gun so contact tip to work distance is about 3/8 to 1/2 inch (10 to 12 mm) and the gun is at proper angle.
4. After you strike the arc, practice the correct electrical stickout. Learn to distinguish it by its sound.
5. When you are sure that you can hold the correct electrical stickout, with a smooth “crackling” arc, start moving. Look at the molten puddle constantly, and look for the ridge where the metal solidifies.
6. Run beads on a flat plate. Run them parallel to the top edge (the edge farthest away from you). This gives you practice in running straight welds, and also gives you an easy way to check your progress. The 10th weld will look considerably better than the first weld. By constantly checking on your mistakes and your progress, welding will soon be a matter of routine.

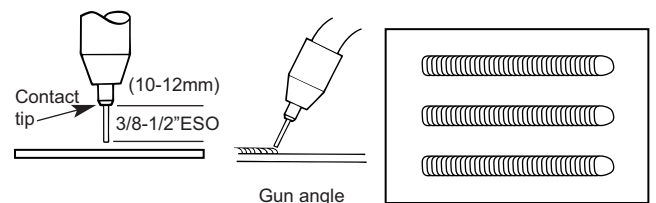

COMMON METALS

Most metals found around the farm, small shop or home are low carbon steel, sometimes referred to as mild steel. Typical items made with this type of steel include most sheet metal, plate, pipe and rolled shapes such as channels and angle irons. This type of

steel can usually be easily welded without special precautions. Some steels, however, contain higher carbon levels or other alloys and are more difficult to weld. Basically, if a magnet sticks to the metal and if you can easily cut the metal with a file, chances are good that you will be able to weld the material with the SP-100. For further information on identifying various types of steels and other metals, and for proper procedures for welding them, we again suggest you purchase a copy of "New Lessons in Arc Welding" (see page 29).

Regardless of the type of metal being welded, it is important in order to get a quality weld that it be free of oil, paint, rust or other contaminant's.

TYPES OF WELDS

Five types of welding joints are: Butt Welds, Fillet Welds, Lap Welds, Edge Welds and Corner Welds.

Of these, the Butt Weld and Fillet Weld are the two most common welds.

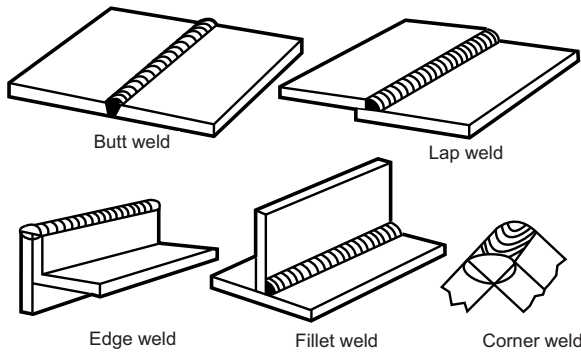

WELDING PROCEDURES

Butt Welds

Place two plates side by side, leaving a space approximately one half the thickness of the metal between them in order to get deeper penetration.

Securely clamp or tack weld the plates at both ends, otherwise the heat will cause the plates to move apart (see drawing):

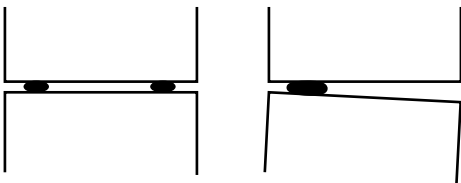

Now weld the two plates together. Weld from left to right (if right handed). Point the wire electrode down in the crack between the two plates, keeping the gun slightly tilted in the direction of travel.

Watch the molten metal to be sure it distributes itself evenly on both edges and in between the plates.

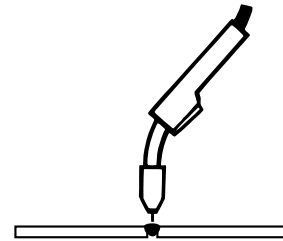

Penetration

Unless a weld penetrates close to 100% of the metal thickness, a butt weld will be weaker than the material welded together. In this example, the total weld is only half the thickness of the material; thus the weld is only approximately half as strong as the metal.

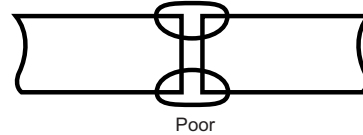

In this example, the joint has been welded so that 100% penetration could be achieved. The weld, if properly made, is as strong as or stronger than the original metal.

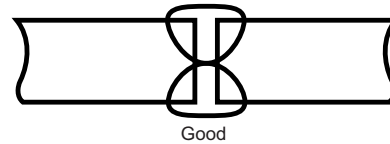

Fillet Welds

When welding fillet welds, it is very important to hold the wire electrode at a 45° angle between the two sides, or the metal will not distribute itself evenly. The gun nozzle is generally formed at an angle to facilitate this.

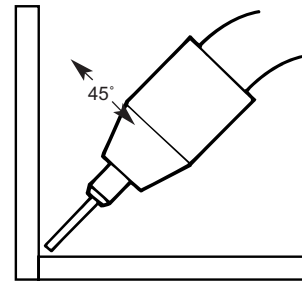

WELDING IN THE VERTICAL POSITION

Welding in the vertical position can be done either vertical-up or vertical-down. Vertical-up is used whenever a larger, stronger weld is desired. Vertical-down is used primarily on sheet metal 5/32" (3.9 mm) and under for fast, low penetrating welds.

WARNING

Use of the SP-100 on thicker materials than recommended may result in poor welds. The welds may "look" good, but may just be "sitting" on top of the plate. This is called "Cold Casting" and will result in weld failure. See Recommended Processes and Equipment.

Vertical-Up and Overhead Welding

The problem, when welding vertical-up, is to put the molten metal where it is wanted and make it stay there. If too much molten metal is deposited, gravity will pull it downwards and make it “drip.” Therefore, a certain technique has to be followed.

When welding out-of-position, run stringer beads. Don't whip, break the arc, move out of the puddle, or move too fast in any direction. Use WFS in the low portion of the range. General techniques are illustrated below.

Generally, keep the electrode nearly perpendicular to the joint as illustrated. The maximum angle above perpendicular may be required if porosity becomes a problem.

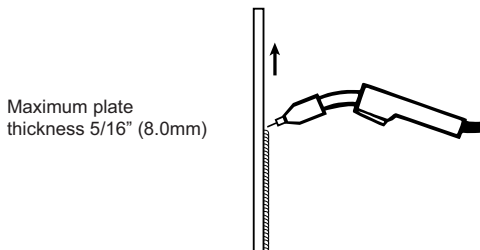

Vertical-Down Welding

Vertical-down welds are applied at a fast pace. These welds are therefore shallow and narrow, and as such are excellent for sheet metal. Vertical-down welds may be applied to 5/32" (3.9 mm) and lighter material. This material is within the range of the SP-100 when used with .035" (0.9 mm) NR-211-MP Innershield electrode.

Use stringer beads and tip the gun in the direction of travel so the arc force helps hold the molten metal in the joint. Move as fast as possible consistent with desired bead shape.

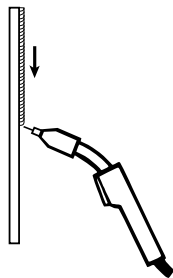

The important thing is to continue lowering the entire arm as the weld is made so the angle of the gun does not change. Move the electrode wire fast enough that the slag does not catch up with the arc. Vertical-down welding gives thin, shallow welds. It **should not** be used on heavy material where large welds are required.

THE GMAW (MIG) WELDING ARC

The drawing below illustrates the GMAW (MIG) welding arc. Solid wire does not contain fluxes or ingredients to form its own shielding and no slag forms to

protect the molten weld metal. For this reason, a continuous even flow of shielding gas is needed to protect the molten weld metal from atmospheric contaminants such as oxygen and nitrogen. Shielding gas is supplied through the gun and cable assembly through the gas nozzle, and into the welding zone.

The shielding gas has several other functions besides protecting the molten weld metal. It helps shape the cross section of the weld deposit, may increase or decrease arc temperature, stabilizes the arc, and regulates penetration.

When comparing the GMAW and FCAW processes, you can see that the principal difference between the two lies in the type of shielding used. GMAW uses gas for shielding, thus we have Gas Metal Arc Welding. FCAW uses the melting or burning of the core ingredients for shielding, and is thus termed Self-Shielded Flux Cored Arc Welding.

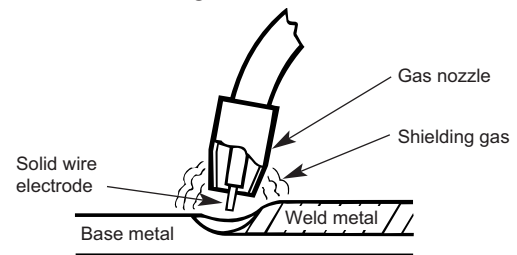

The recommended wire for Gas Metal Arc Welding (MIG) is Lincolnweld® .025" L-56 electrode. Lincolnweld® L-56 is capable of welding a wide range of mild steels in all positions, however, more skill is required for out-of-position welding with the GMAW process.

PROCESS SELECTION

By gaining knowledge of the differences between the two processes, you will be able to select the best process for the job you have at hand. In selecting a process, you should consider:

For GMAW (MIG) process

1. Is most of my welding performed on 16 gauge and lighter materials?
2. Can I afford the extra expense, space, and lack of portability required for gas cylinders and gas supply lines?
3. Do I require clean, finished-looking welds?

If you have answered yes to all the above questions, GMAW may be the process for you. If you have answered no to any of the above questions then you should consider using the FCAW process.

For FCAW (Innershield) process

1. Do I want simplicity and portability?
2. Will welding be performed outdoors or under windy conditions?
3. Do I require good all position welding capability?
4. Will most welding be performed on 16 gauge and heavier, somewhat rusty or dirty materials?
5. Weld must be cleaned prior to painting.

MACHINE SETUP FOR THE GMAW (MIG) PROCESS

1. See "Recommended Processes and Equipment" for selection of welding wire and shielding gas and for range of metal thicknesses that can be welded.
2. See the "Welding" chart on the inside of wire feed section door or in this manual for information on setting the controls.
3. Set the "Voltage" and "Wire Speed" controls to the settings suggested for the welding wire and base metal thickness being used. The voltage control is marked "V" and the wire feed speed is marked olo.
4. Check that the polarity is correct for the welding wire being used. Set the polarity for DC(+) when welding with the GMAW (MIG) process. (See page 9 of the Installation Instructions on how to make output polarity connections.)
5. Check that the gas nozzle and proper size liner and contact tip are being used, and that the gas supply is turned on. If adjustable, set for 15 to 20 cubic feet per hour (7 to 10 liters/min) under normal conditions; increase as high as 35 CFH (17 liters/min) under drafty (slightly windy) conditions.
NOTE: The gas regulators included in the optional K463 and K499 kits are preset and nonadjustable.
6. Connect work clamp to metal to be welded. Work clamp must make good electrical contact to the workpiece. The workpiece must also be grounded as stated in "Arc Welding Safety Precautions."

WELDING TECHNIQUES FOR THE GMAW (MIG) PROCESS

The welding techniques for the GMAW (MIG) process on light gauge material are basically the same as welding with .035" (0.9 mm) NR-211-MP Innershield electrode. (Review welding techniques in the self-shielded FCAW Innershield section on page 14.) The few exceptions are noted below.

The Correct Welding Position

When using the GMAW process on light gauge material, weld from right to left (if right handed) pushing the electrode ahead of the arc (see figure following). This technique results in a colder weld and has less tendency for burnthrough. You may weld in the opposite direction as long as you are obtaining desirable results.

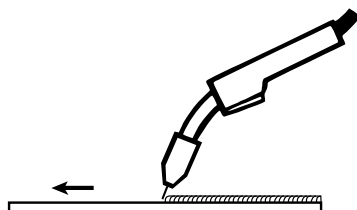

Push Technique

The Correct Way to Strike an Arc

1. The arc is struck the same as for self-shielded FCAW welding. However, for easier restrikes, the ball at the tip end of the wire which forms after completing a weld may be removed with wire cutters.
2. When no more welding is to be done, don't forget to first close valve on gas cylinder (if used), momentarily

operate gun trigger to release gas pressure, then turn off the machine.

The Correct Electrical Stickout

The electrical stickout (ESO) for GMAW (MIG) welding is 3/8 to 1/2 inch (10 to 12 mm). The same rules apply as when welding with .035" (0.9 mm) NR-211-MP Innershield wire.

The Correct Welding Speed

The same rules apply as those for self-shielded FCAW welding. At first, it may be more difficult to judge speed since no slag is forming behind the molten pool. Watch the ridge where the molten puddle solidifies.

Practice

To practice your GMAW (MIG) welding skills, use the following:

Mild steel	16 gauge (about 1/16 inch)
Electrode	Lincolnweld® .025 L-56 electrode
Shielding gas	CO ₂
Voltage setting "V"	G
Wire feed speed olo	5

Then follow the instructions in the practice section on self-shielded FCAW welding.

WELDING PROCEDURES

When GMAW (MIG) welding on sheet metal, remember to use the "forehand" push technique, and review the welding procedures section on self-shielded FCAW Innershield welding.

Welding in the Vertical Position

One variation of welding procedure is welding in the vertical-up position. When welding in the vertical-up position, use the proper gun angle shown below.

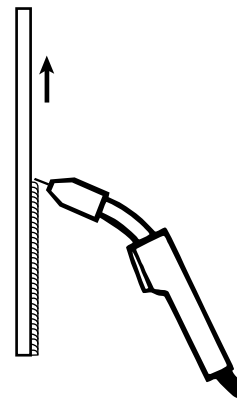

Gun angle for the GMAW process welding in the vertical-up position.

TROUBLESHOOTING WELDS

Good welds have excellent appearance.

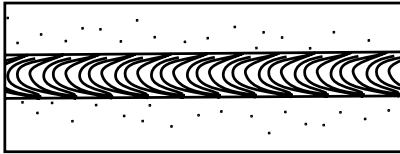

To Eliminate Porosity (in order of importance) —

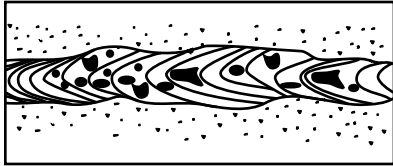

Turn on gas supply, if used

1. Decrease voltage
2. Increase stickout
3. Increase WFS (wire feed speed)
4. Decrease drag angle
5. Decrease travel speed.

NOTE: Always be sure the joint is free from moisture, oil, rust, paint or other contaminants.

To Eliminate a Ropy Convex Bead (in order of importance)

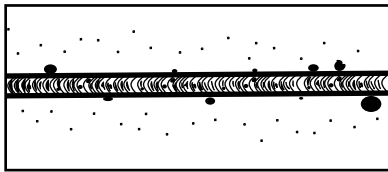

1. Increase voltage
2. Decrease stickout
3. Decrease WFS (wire feed speed)
4. Decrease travel speed
5. Decrease drag angle
6. Check for correct gas, if used

To Reduce Spatter (in order of importance)

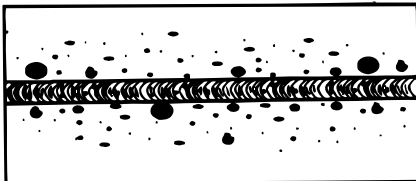

1. Increase voltage
2. Increase drag angle
3. Decrease stickout
4. Increase WFS (wire feed speed)
5. Decrease travel speed
6. Check for correct gas, if used

To Correct Poor Penetration (in order of importance)

1. Decrease stickout
2. Increase WFS (wire feed speed) ("olo")
3. Decrease voltage ("V")
4. Increase speed
5. Decrease drag angle
6. Check for correct gas, if used

If Arc Blow Occurs (in order of importance)

(NOTE: Try different ground connection locations before adjusting procedures)

1. Decrease drag angle
2. Increase stickout
3. Decrease voltage ("V")
4. Decrease WFS (wire feed speed) ("olo") and voltage ("V")
5. Decrease travel speed

To Eliminate Stubbing (in order of importance)

1. Increase voltage ("V")
2. Decrease WFS (wire feed speed) ("olo")
3. Decrease stickout
4. Increase drag angle

Stubbing occurs when the electrode drives through the molten puddle and hits the bottom plate tending to push the gun up.

PROPER GUN HANDLING

Most feeding problems are caused by improper handling of the gun cable or electrodes.

1. Do not kink or pull the gun cable around sharp corners.
2. Keep the gun cable straight as practical when welding.
3. Do not allow dolly wheels or trucks to run over the cables.
4. Keep the cable clean per maintenance instructions in this Operation Manual.
5. Innershield electrode has proper surface lubrication. Use only clean, rust-free electrode.
6. Replace the contact tip when it becomes worn or the end is fused or deformed.

ROUTINE MAINTENANCE

WARNING



ELECTRIC SHOCK can kill.

- Disconnect input power by removing plug from receptacle before working inside SP-100.
- Use only grounded receptacle.
- Do not touch electrically "hot" parts inside SP-100.
- Have qualified personnel do the maintenance and troubleshooting work.

Requires NO Maintenance

- Drive Motor and Gearbox - Lifetime lubrication
- Fan Motor - Lifetime lubrication.
- Wire Reel Spindle - Do NOT lubricate shaft.

Before Each Use

- Check over machine and accessories for any obvious condition that may prevent safe performance or operation, repair or replace items as necessary to correct any abnormal condition.

After 5 minutes of welding or when spatter accumulates in nozzle

- Clean nozzle to avoid bridging between nozzle and contact tip which results in shorted nozzle, poor welds and overheated gun. Hint: Anti-stick spray or gel available from a welding supply distributor may reduce buildup and aid in spatter removal.

After each spool of wire feed

- Remove contact tip and clean inside diameter with short piece of wire
- Clean cable liner - when rough and erratic wirefeeding occur.

After feeding 50# of Flux Cored Wire or 300# of Solid Wire

Unplug machine or turn power switch to OFF - "O" position.

Remove gun and cable from machine.

Remove gas nozzle and contact tip from gun

Lay cable out straight - blow out gently with compressed air - Bend cable back and forth - blow out again - Repeat until clean. CAUTION Excessive pressure at start may cause the dirt to form a plug.

Periodically As Required

- Blow dirt out of the welder with low pressure air to eliminate excessive dirt and dust buildup that could cause welder to run hot.
- Vacuum accumulated dirt from gearbox and wire feed section.
- Inspect the incoming guide tube and clean inside diameter if necessary. Replace when excessively worn.
- Replace Contact Tip - when hole is enlarged or elongated
Unplug machine or turn power switch to OFF - "O" position.
Unscrew nozzle by turning counterclockwise.
Unscrew contact tip by turning counterclockwise
Replace contact tip - use correct size - see stencil on tip - tighten snugly.
Replace gas nozzle.

- Replace Liner - when wire feeding problems occur and other items have been checked.
NOTICE: The variation in cable lengths prevents the interchangeability of liners. Once a liner has been cut for a particular gun, it should not be installed in another gun unless it can meet the liner cutoff length requirement.

Remove gun and cable assembly from machine.

Remove the nozzle according to the instructions in contact tip replacement.

Remove the gas diffuser from the gun tube by unscrewing counterclockwise.

Lay the gun and cable out straight on a flat surface. Loosen the set screw located in the brass connector at the wire feeder end of the cable. Pull the liner out of the cable.

Insert a new untrimmed liner into the connector end of the cable. Be sure the liner bushing is stencilled appropriately for the wire size being used.

Fully seat the liner bushing into the connector. Tighten the set screw on the brass cable connector. At this time, the gas diffuser should not be installed onto the end of the gun tube.

With the gas nozzle and diffuser removed from the gun tube, be sure the cable is straight, and then trim the liner to the length shown in the diagram below. Remove any burrs from the end of the liner.

Screw the gas diffuser onto the end of the gun tube and securely tighten. Replace the contact tip and nozzle.

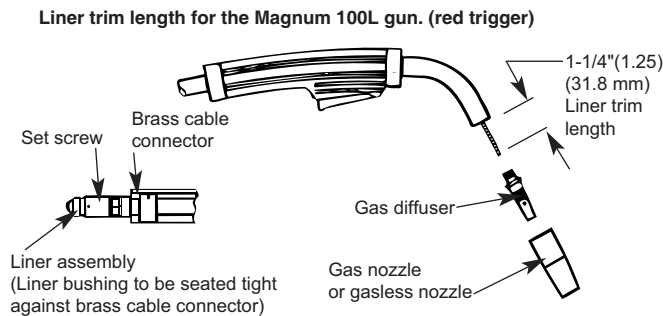

- Replace internal gun handle parts as necessary.

The gun handle consists of two halves that are held together with a collar on each end. To open up the handle, turn the collars approximately 60 degrees counterclockwise (the same direction as removing a right hand thread) until the collar reaches a stop. Then pull the collar off the gun handle. If the collars are difficult to turn, position the gun handle against a corner, place a screwdriver against the tab on the collar and give the screwdriver a sharp blow to turn the collar past an internal locking rib.

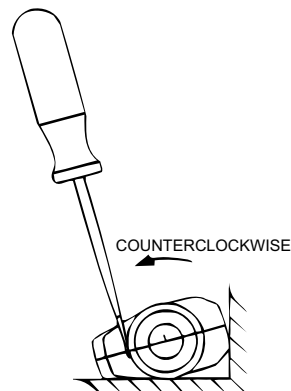

GENERAL TROUBLESHOOTING GUIDE

⚠ WARNING



ELECTRIC SHOCK can kill.

- Disconnect input power by removing plug from receptacle before working inside SP-100.
- Use only grounded receptacle.
- Do not touch electrically "hot" parts inside SP-100.
- Have qualified personnel do the maintenance and troubleshooting work.

Problems

Problem	Possible Cause	What To Do
No Wire Feed, Weld Output or Gas Flow	Welder not ON ("I")	Turn welder power ON ("I")
	Welder not plugged in	Plug in - check both ends of input cable
	Gun Cable Damaged	Inspect or Replace
	Trigger Switch Problem	Repair or Replace
	Circuit breaker or Thermostat Tripped	See "Overload Protection Shutdown" Section
No Arc, Weak Arc	Poor ground connection to work	Check ground connection
	Gun or Power cable connection loose	Check - repair or replace cable or connectors
	Voltage set too low	Adjust Voltage
	Tip too large for wire size	Use correct tip
No Wire Feed	Wire spool or reel empty	Install new spool or reel
	Drive Roll size incorrect	Change Drive Roll - Refer to proper section
	Drive Roll worn	Replace
	Wire Drive release open	Close wire drive release
	Wire welded to tip	Peel wire off or use new tip
	Kink or bend in Wire	Remove wire, cut out kink, reload wire
	Tip or cable liner too small for wire	Insert correct tip or liner
	Trigger circuit connections loose	Check connections
	Dirty or Worn cable liner	Clean or Replace - Refer to proper section
Wire feed too fast or slow	Wrong speed set for work	Adjust wire feed speed at machine

Low or no gas flow	Cylinder valve closed	Open cylinder valve
	Gas flow not set correctly	Set proper flow rate
	Cylinder out of gas	Get new cylinder of gas
	Leak in gas line	Inspect and replace
	Clog or Leak in gun	Check for obstruction or defective seals
Arc unstable	Wrong welding polarity	Check polarity - Refer to proper section
Erratic or Intermittent Arc - Poor Starting "Hunting" Arc	Wrong size, worn and/or melted contact tip	Replace tip - remove any spatter on end of tip
	Worn work cable or poor connections	Inspect - repair or replace as necessary
	Loose electrode connections	Be sure electrode lead is tight, gun cable tight in wire feeder contact block, gun nozzle and gun tip tight

SP 100 WIRING DIAGRAM



- Do not operate with covers removed.
- Disconnect input power by unplugging power cord before servicing
- Do not touch electrically live parts
- Only qualified persons should install, use or service this machine.

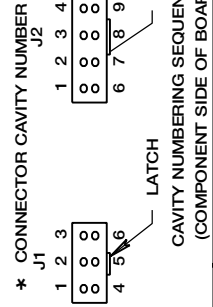
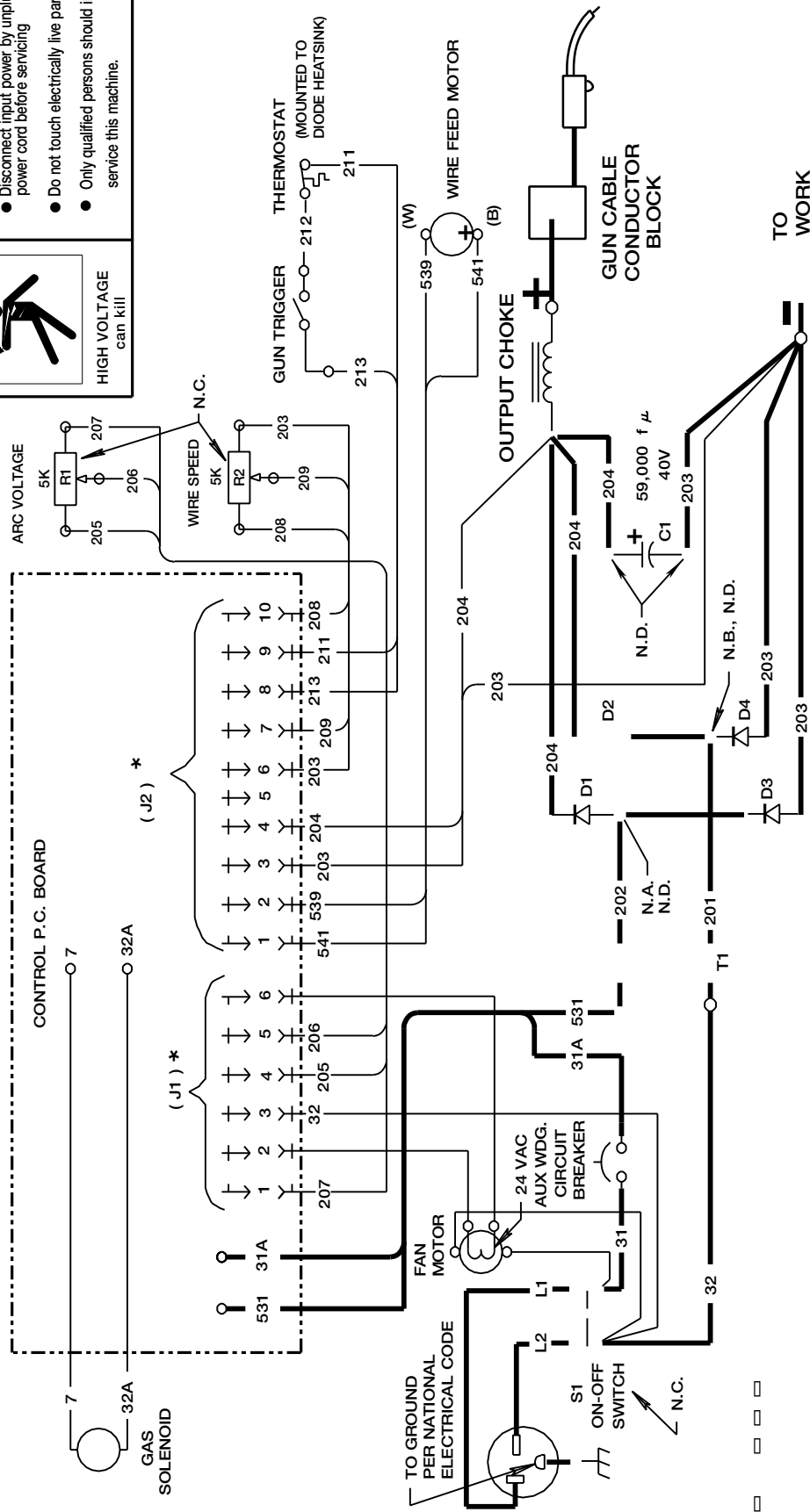

NOTES:
 N.A. DIODES D1 & D3 ARE MOUNTED ON THE OUTSIDE HEATSINK.
 N.B. DIODES D2 & D4 ARE MOUNTED ON THE INSIDE HEATSINK, WHICH IS CLOSEST TO THE CENTER PANEL.
 N.C. COMPONENT VIEWED FROM REAR.
 N.D. BOLTED ALUMINUM CONNECTIONS REQUIRE JOINT COMPOUND. SEE OPERATING MANUAL WHEN REATTACHING.

ELECTRICAL SYMBOLS PER E1537
 LEAD COLOR CODE:
 B-BLACK W-WHITE

Be sure to read and understand the warnings on this power source and the section on ARC WELDING SAFETY PRECAUTIONS in the SP-100 Operating Manual.

ADJUST VOLTAGE CONTROL TO ACHIEVE OPTIMUM WELD AT SPECIFIED WIRE SPEED SETTING⁽²⁾
SUGGESTED VOLTAGE & WIRE SPEED SETTINGS
STEEL MATERIAL THICKNESS

ELECTRODE	SHIELDING GAS	STEEL MATERIAL THICKNESS							
		24 ga. (.024)	22 ga. (.030)	20 ga. (.036)	18 ga. (.048)	16 ga. (.060)	14 ga. (.075)	12 ga. (.105)	
.025 in. (.6 mm) DIA. SOLID STEEL ⁽¹⁾ WIRE DC(+)	CO ₂	E-2.5	E-3	F-4	F-4.5	G-5	J-6	N.R.	
	C20 or C25 (75-80% Argon 25-20% CO ₂)	C-2.5 ⁽⁵⁾	D-3	E-4	F-5.5	G-6.5	H-7	J-8 ⁽³⁾	
.030 in. (.8 mm) DIA. SOLID STEEL WIRE DC(+)	CO ₂	N.R.	E-3.0	F-3.5	F-4.0	G-4.5	H-4.5	N.R.	
	C20 or C25 (75-80% Argon 25-20% CO ₂)	N.R.	D-3.0	E-3.5	E-4	F-4.5	G-4.5	J-5.5 ⁽³⁾	
.035 in. (.9 mm) DIA. INNERSHIELD® NR-211-MP DC(-)	NONE	N.R.	N.R.	C-1	D-1.5	E-2	F-2.5 ⁽⁴⁾	G-3 ^(3,4)	

N.R. — Not Recommended

INSTALL SPOOL OF WIRE TO DEREEEL CLOCKWISE



- (1) Also .024 and .023 inch diameter.
- (2) Optimum voltage control setting is influenced by input voltage.
- (3) Maximum output setting — do not use unless connected to a 25 amp branch circuit.
- (4) These settings may also be used on 1/8 and 5/16 steel with multiple passes.
- (5) Use DC(-) polarity on 24 gage to reduce burnthrough.

WIRE SIZE STENCILED ON VISIBLE SIDE OF DRIVE ROLL MUST BE SAME AS WIRE SIZE BEING USED.

IF NOT, REVERSE DRIVE ROLL PER THE FOLLOWING INSTRUCTIONS:

1. Release idle roll pressure arm and swing idle roll away from drive roll.
2. Remove the screw and washer from the drive shaft and slide the drive roll off the drive shaft.
3. Install the drive roll with the required stenciled size facing out onto the drive shaft. Key in drive shaft must remain in place. Install screw and tighten.
4. Feed wire through the guide tubes and close idle roll. See Operating Manual for idle roll pressure setting.

PROCEDURE TO CHANGE ELECTRODE POLARITY (See column under "Electrode" in table above for recommended polarity.)

DC(+) ● **ELECTRODE POSITIVE**
Connect the cable from the gun and cable conductor block to the positive (+) output stud, and connect the "work" cable to the negative (-) output stud.

DC(-) ● **ELECTRODE NEGATIVE**
Connect the cable from the gun and cable conductor block to the negative (-) output stud, and connect the "work" cable to the positive (+) output stud.

Because design, fabrication, assembly and welding variables affect the results obtained in applying this type of information, the serviceability of a product or assembly is the responsibility of the builder/user.

			
WARNING	<ul style="list-style-type: none"> ● Do not touch electrically live parts or electrode with skin or wet clothing. ● Insulate yourself from work and ground. 	<ul style="list-style-type: none"> ● Keep flammable materials away. 	<ul style="list-style-type: none"> ● Wear eye, ear and body protection.
Spanish AVISO DE PRECAUCION	<ul style="list-style-type: none"> ● No toque las partes o los electrodos bajo carga con la piel o ropa mojada. ● Aíslese del trabajo y de la tierra. 	<ul style="list-style-type: none"> ● Mantenga el material combustible fuera del área de trabajo. 	<ul style="list-style-type: none"> ● Protéjase los ojos, los oídos y el cuerpo.
French ATTENTION	<ul style="list-style-type: none"> ● Ne laissez ni la peau ni des vêtements mouillés entrer en contact avec des pièces sous tension. ● Isolez-vous du travail et de la terre. 	<ul style="list-style-type: none"> ● Gardez à l'écart de tout matériel inflammable. 	<ul style="list-style-type: none"> ● Protégez vos yeux, vos oreilles et votre corps.
German WARNUNG	<ul style="list-style-type: none"> ● Berühren Sie keine stromführenden Teile oder Elektroden mit Ihrem Körper oder feuchter Kleidung! ● Isolieren Sie sich von den Elektroden und dem Erdboden! 	<ul style="list-style-type: none"> ● Entfernen Sie brennbares Material! 	<ul style="list-style-type: none"> ● Tragen Sie Augen-, Ohren- und Körperschutz!
Portuguese ATENÇÃO	<ul style="list-style-type: none"> ● Não toque partes elétricas e electrodos com a pele ou roupa molhada. ● Isole-se da peça e terra. 	<ul style="list-style-type: none"> ● Mantenha inflamáveis bem guardados. 	<ul style="list-style-type: none"> ● Use proteção para a vista, ouvido e corpo.
Japanese 注意事項	<ul style="list-style-type: none"> ● 通電中の電気部品、又は溶材にヒフやぬれた布で触れないこと。 ● 施工物やアースから身体が絶縁されている様にして下さい。 	<ul style="list-style-type: none"> ● 燃えやすいものの側での溶接作業は絶対にしてはなりません。 	<ul style="list-style-type: none"> ● 目、耳及び身体に保護具をして下さい。
Chinese 警告	<ul style="list-style-type: none"> ● 皮肤或湿衣物切勿接触带电部件及焊条。 ● 使你自已与地面和工作件绝缘。 	<ul style="list-style-type: none"> ● 把一切易燃物品移离工作场所。 	<ul style="list-style-type: none"> ● 佩戴眼、耳及身体劳动保护用具。
Korean 위험	<ul style="list-style-type: none"> ● 전도체나 용접봉을 젖은 형갑 또는 피부로 절대 접촉치 마십시오. ● 모재와 접지를 접촉치 마십시오. 	<ul style="list-style-type: none"> ● 인화성 물질을 접근시키지 마십시오. 	<ul style="list-style-type: none"> ● 눈, 귀와 몸에 보호장구를 착용하십시오.
Arabic تحذير	<ul style="list-style-type: none"> ● لا تلمس الاجزاء التي يسري فيها التيار الكهربائي أو الألكترود بجسد الجسم أو بالملابس المبللة بالماء. ● ضع عازلا على جسمك خلال العمل. 	<ul style="list-style-type: none"> ● ضع المواد القابلة للاشتعال في مكان بعيد. 	<ul style="list-style-type: none"> ● ضع أدوات وملابس واقية على عينيك وأذنيك وجسمك.

READ AND UNDERSTAND THE MANUFACTURER'S INSTRUCTION FOR THIS EQUIPMENT AND THE CONSUMABLES TO BE USED AND FOLLOW YOUR EMPLOYER'S SAFETY PRACTICES.

SE RECOMIENDA LEER Y ENTENDER LAS INSTRUCCIONES DEL FABRICANTE PARA EL USO DE ESTE EQUIPO Y LOS CONSUMIBLES QUE VA A UTILIZAR, SIGA LAS MEDIDAS DE SEGURIDAD DE SU SUPERVISOR.

LISEZ ET COMPRENEZ LES INSTRUCTIONS DU FABRICANT EN CE QUI REGARDE CET EQUIPMENT ET LES PRODUITS A ETRE EMPLOYES ET SUIVEZ LES PROCEDURES DE SECURITE DE VOTRE EMPLOYEUR.

LESEN SIE UND BEFOLGEN SIE DIE BETRIEBSANLEITUNG DER ANLAGE UND DEN ELEKTRODENEINSATZ DES HERSTELLERS. DIE UNFALLVERHÜTUNGSVORSCHRIFTEN DES ARBEITGEBERS SIND EBENFALLS ZU BEACHTEN.

			
<ul style="list-style-type: none"> ● Keep your head out of fumes. ● Use ventilation or exhaust to remove fumes from breathing zone. 	<ul style="list-style-type: none"> ● Turn power off before servicing. 	<ul style="list-style-type: none"> ● Do not operate with panel open or guards off. 	WARNING
<ul style="list-style-type: none"> ● Los humos fuera de la zona de respiración. ● Mantenga la cabeza fuera de los humos. Utilice ventilación o aspiración para gases. 	<ul style="list-style-type: none"> ● Desconectar el cable de alimentación de poder de la máquina antes de iniciar cualquier servicio. 	<ul style="list-style-type: none"> ● No operar con panel abierto o guardas quitadas. 	Spanish AVISO DE PRECAUCION
<ul style="list-style-type: none"> ● Gardez la tête à l'écart des fumées. ● Utilisez un ventilateur ou un aspirateur pour ôter les fumées des zones de travail. 	<ul style="list-style-type: none"> ● Débranchez le courant avant l'entretien. 	<ul style="list-style-type: none"> ● N'opérez pas avec les panneaux ouverts ou avec les dispositifs de protection enlevés. 	French ATTENTION
<ul style="list-style-type: none"> ● Vermeiden Sie das Einatmen von Schweißrauch! ● Sorgen Sie für gute Be- und Entlüftung des Arbeitsplatzes! 	<ul style="list-style-type: none"> ● Strom vor Wartungsarbeiten abschalten! (Netzstrom völlig öffnen; Maschine anhalten!) 	<ul style="list-style-type: none"> ● Anlage nie ohne Schutzgehäuse oder Innenschutzverkleidung in Betrieb setzen! 	German WARNUNG
<ul style="list-style-type: none"> ● Mantenha seu rosto da fumaça. ● Use ventilação e exaustão para remover fumo da zona respiratória. 	<ul style="list-style-type: none"> ● Não opere com as tampas removidas. ● Desligue a corrente antes de fazer serviço. ● Não toque as partes elétricas nuas. 	<ul style="list-style-type: none"> ● Mantenha-se afastado das partes moventes. ● Não opere com os painéis abertos ou guardas removidas. 	Portuguese ATENÇÃO
<ul style="list-style-type: none"> ● ヒュームから頭を離すようにして下さい。 ● 換気や排煙に十分留意して下さい。 	<ul style="list-style-type: none"> ● メンテナンス・サービスに取りかかる際には、まず電源スイッチを必ず切って下さい。 	<ul style="list-style-type: none"> ● パネルやカバーを取り外したまま機械操作をしないで下さい。 	Japanese 注意事項
<ul style="list-style-type: none"> ● 頭部遠離煙霧。 ● 在呼吸區使用通風或排風器除煙。 	<ul style="list-style-type: none"> ● 維修前切斷電源。 	<ul style="list-style-type: none"> ● 儀表板打開或沒有安全罩時不準作業。 	Chinese 警告
<ul style="list-style-type: none"> ● 얼굴로부터 용접가스를 멀리하십시오. ● 호흡지역으로부터 용접가스를 제거하기 위해 가스제거기나 통풍기를 사용하십시오. 	<ul style="list-style-type: none"> ● 보수전에 전원을 차단하십시오. 	<ul style="list-style-type: none"> ● 판넬이 열린 상태로 작동치 마십시오. 	Korean 위험
<ul style="list-style-type: none"> ● ابعد رأسك بعيداً عن الدخان. ● استعمل التهوية أو جهاز ضغط الدخان للخارج لكي تبعد الدخان عن المنطقة التي تتنفس فيها. 	<ul style="list-style-type: none"> ● أقطع التيار الكهربائي قبل القيام بأية صيانة. 	<ul style="list-style-type: none"> ● لا تشغيل هذا الجهاز اذا كانت الاغطية الحديدية الواقية ليست عليه. 	Arabic تحذير

LEIA E COMPREENDA AS INSTRUÇÕES DO FABRICANTE PARA ESTE EQUIPAMENTO E AS PARTES DE USO, E SIGA AS PRÁTICAS DE SEGURANÇA DO EMPREGADOR.

使う機械や溶材のメーカーの指示書をよく読み、まず理解して下さい。そして貴社の安全規定に従って下さい。

請詳細閱讀並理解製造廠提供的說明以及應該使用的銀焊材料，並請遵守貴方的有閣勞動保護規定。

이 제품에 동봉된 작업지침서를 숙지하시고 귀사의 작업자 안전수칙을 준수하시기 바랍니다.

اقرأ بتمعن وافهم تعليمات المصنع المنتج لهذه المعدات والمواد قبل استعمالها واتبع تعليمات الوقاية لصاحب العمل.



LIMITED WARRANTY

STATEMENT OF WARRANTY:

The Lincoln Electric Company (Lincoln) warrants to the original purchaser (end-user) of new equipment that it will be free of defects in workmanship and material.

This warranty is void if Lincoln finds that the equipment has been subjected to improper care or abnormal operation.

WARRANTY PERIOD:

All warranty periods date from the date of shipment to the original purchaser and are as follows:

Three Years:

- Transformer Welders
- Motor-generator Welders
- Semiautomatic Wire Feeders
- Plasma-cutting Power Source
- Engine-driven Welders (except engine and engine accessories) with operating speed under 2,000 RPM

Two Years:

- Engine-driven Welders (except engine and engine accessories) with operating speed over 2,000 RPM

All engine and engine accessories are warranted by the engine or engine accessory manufacturer and are not covered by this warranty.

Equipment not listed above such as guns and cable assemblies, automatic wire feeders and field-installed optional equipment is warranted for one year.

TO OBTAIN WARRANTY COVERAGE:

You are required to notify Lincoln Electric, your Lincoln Distributor, Lincoln Service Center or Field Service Shop of any defect within the warranty period. Written notification is recommended.

WARRANTY REPAIR:

If Lincoln's inspection of the equipment confirms the existence of a defect covered by this warranty, the defect will be corrected by repair or replacement at Lincoln's option.

WARRANTY COSTS:

You must bear the cost of shipping the equipment to a Lincoln Service Center or Field Service Shop as well as return shipment to you from that location.

IMPORTANT WARRANTY LIMITATIONS:

- Lincoln will not accept responsibility for repairs made without its authorization.
- Lincoln shall not be liable for consequential damages (such as loss of business, etc.) caused by the defect or reasonable delay in correcting the defect.
- Lincoln's liability under this warranty shall not exceed the cost of correcting the defect.
- This written warranty is the only express warranty provided by Lincoln with respect to its products. Warranties implied by law such as the Warranty of Merchantability are limited to the duration of this limited warranty for the equipment involved.

WARRANTY SUPERSEDED SEE MMS1

