

CLASSIC 300D WIRING DIAGRAM M21684 REV: A

CONTROL PANEL COMPONENTS SHOWN AS VIEWED FROM REAR.

*LEADS CONNECTED TO ENGINE IDLER/ENGINE P.C. BOARD, SEE DETAIL

LEAD COLOR CODE	
B-BLACK OR GRAY	R-RED OR PINK
G-GREEN	U-BLUE
N-BROWN	W-WHITE
	Y-YELLOW

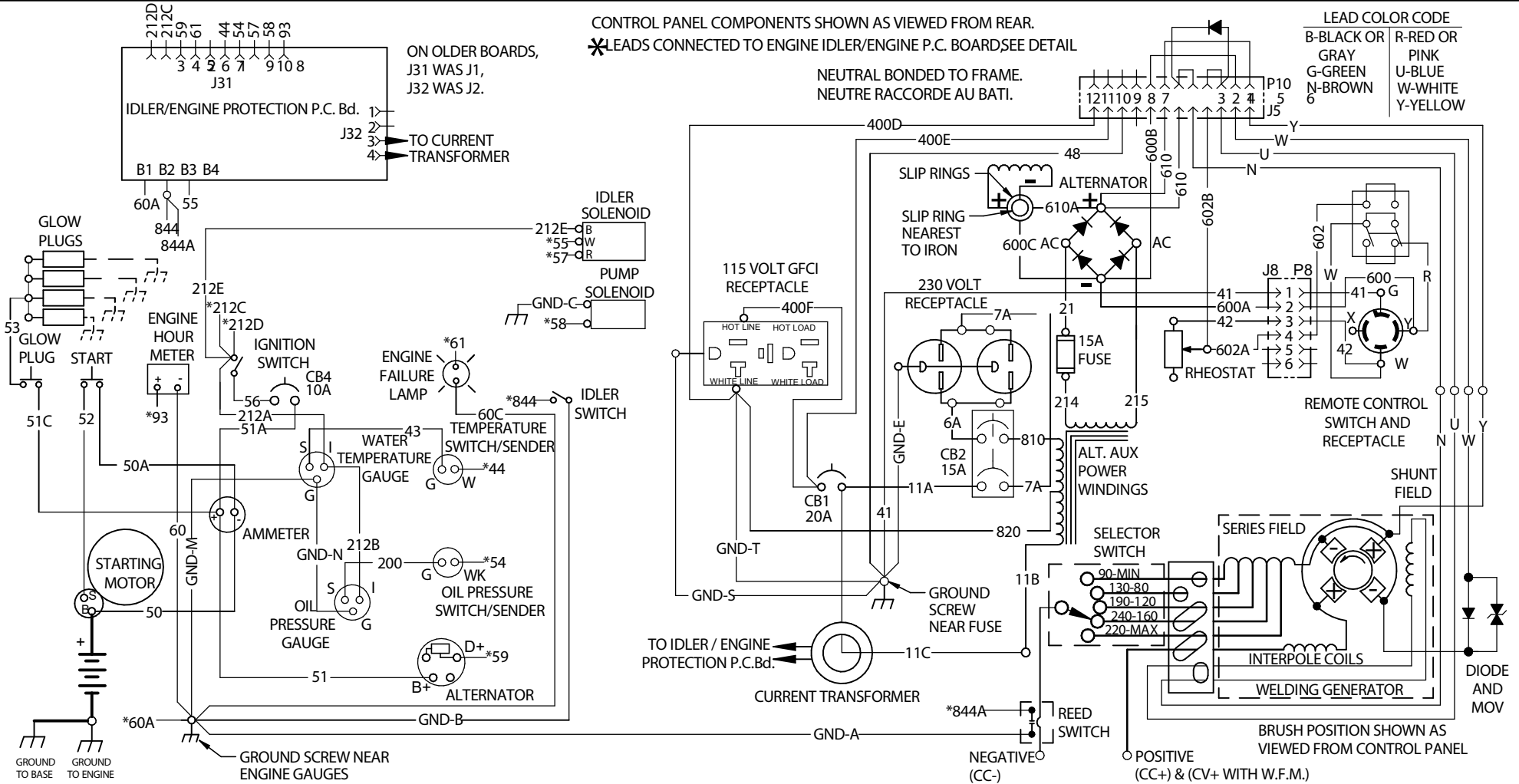

K924-5 REMOTE CONTROL (OPTIONAL)

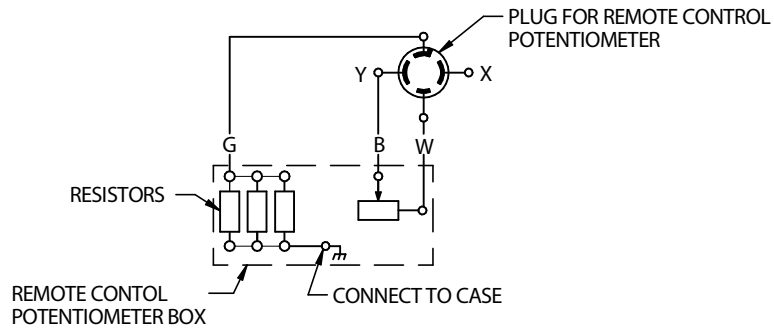

WIRE FEED MODULE (OPTIONAL)

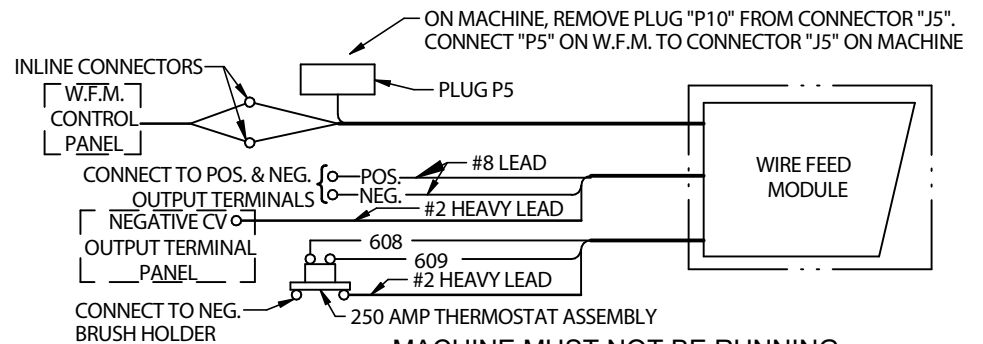

MACHINE MUST NOT BE RUNNING WHEN MAKING THESE CONNECTIONS.