

FLEXTEC 450 WIRING DIAGRAM G6890 REV: A

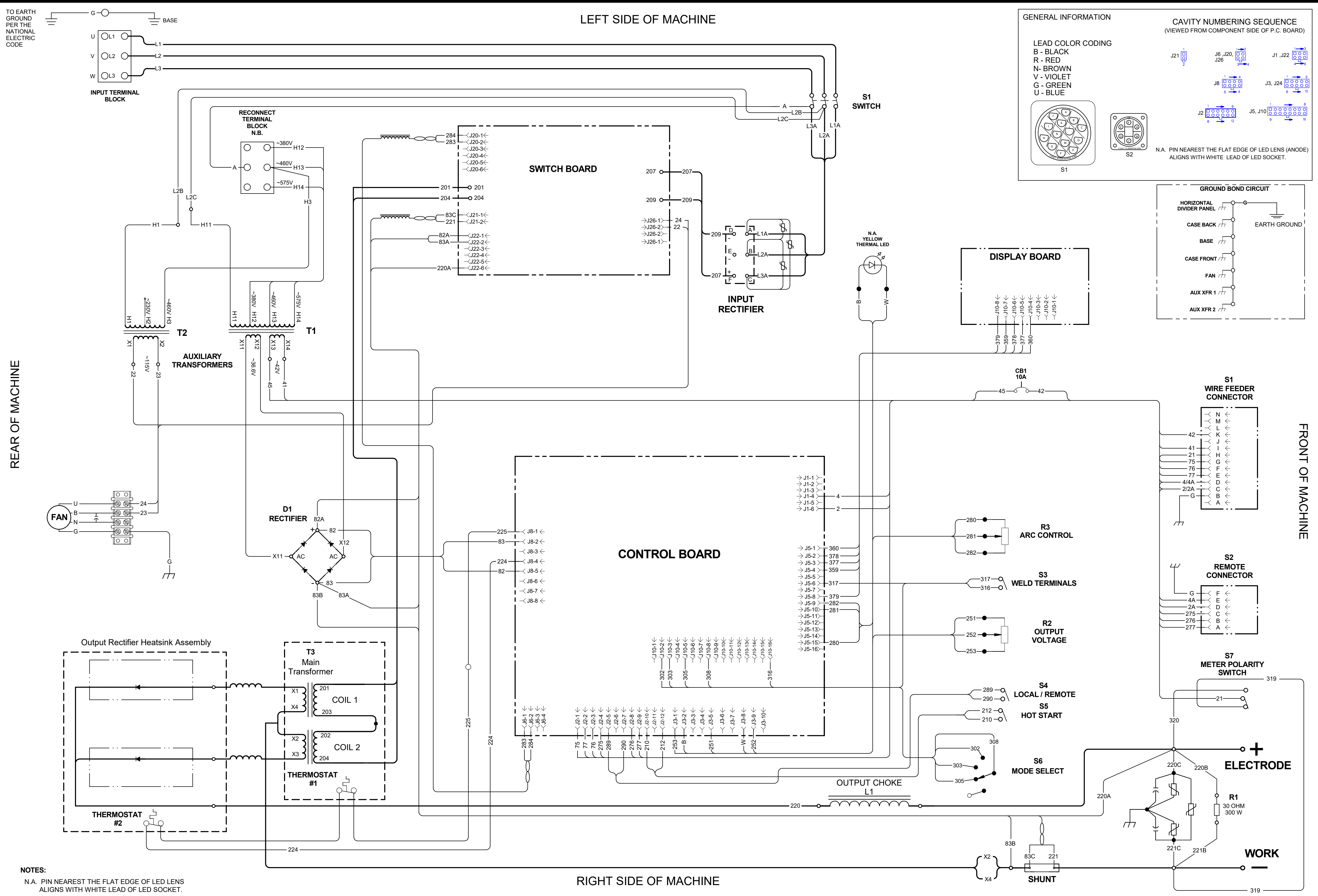

GENERAL INFORMATION

LEAD COLOR CODING
 B - BLACK
 R - RED
 N - BROWN
 V - VIOLET
 G - GREEN
 U - BLUE

CAVITY NUMBERING SEQUENCE
 (VIEWED FROM COMPONENT SIDE OF P.C. BOARD)

S1, S2

N.A. PIN NEAREST THE FLAT EDGE OF LED LENS (ANODE) ALIGNS WITH WHITE LEAD OF LED SOCKET.

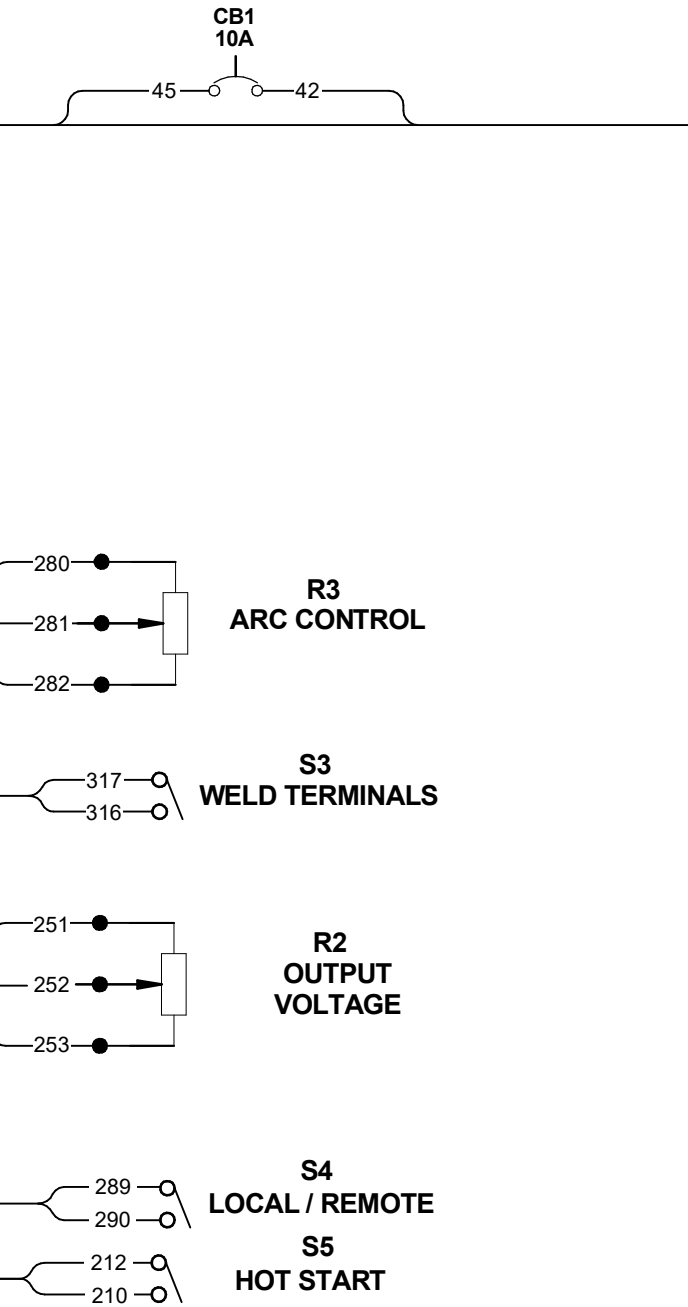
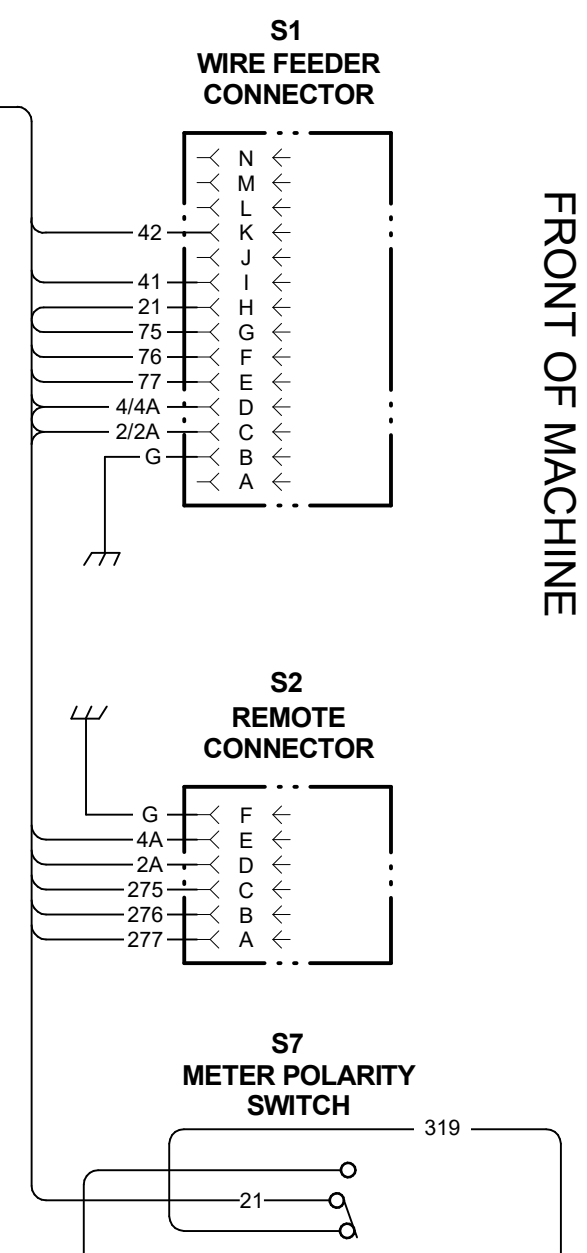
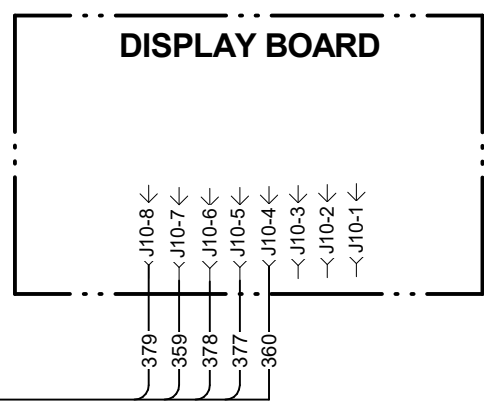
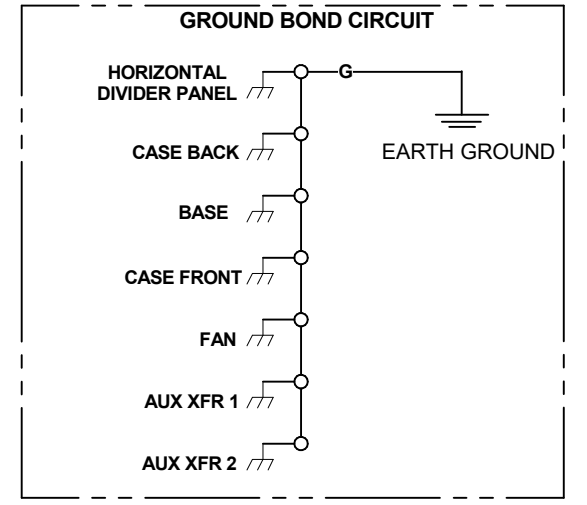

NOTES:

N.A. PIN NEAREST THE FLAT EDGE OF LED LENS ALIGNS WITH WHITE LEAD OF LED SOCKET.

N.B. PLACE "A" LEAD ON APPROPRIATE CONNECTION FOR INPUT VOLTAGE. CONNECTION SHOWN IS FOR 460 V OPERATION.

RIGHT SIDE OF MACHINE

