

POWER WAVE 455 WIRING DIAGRAM G4420-2 REV: B

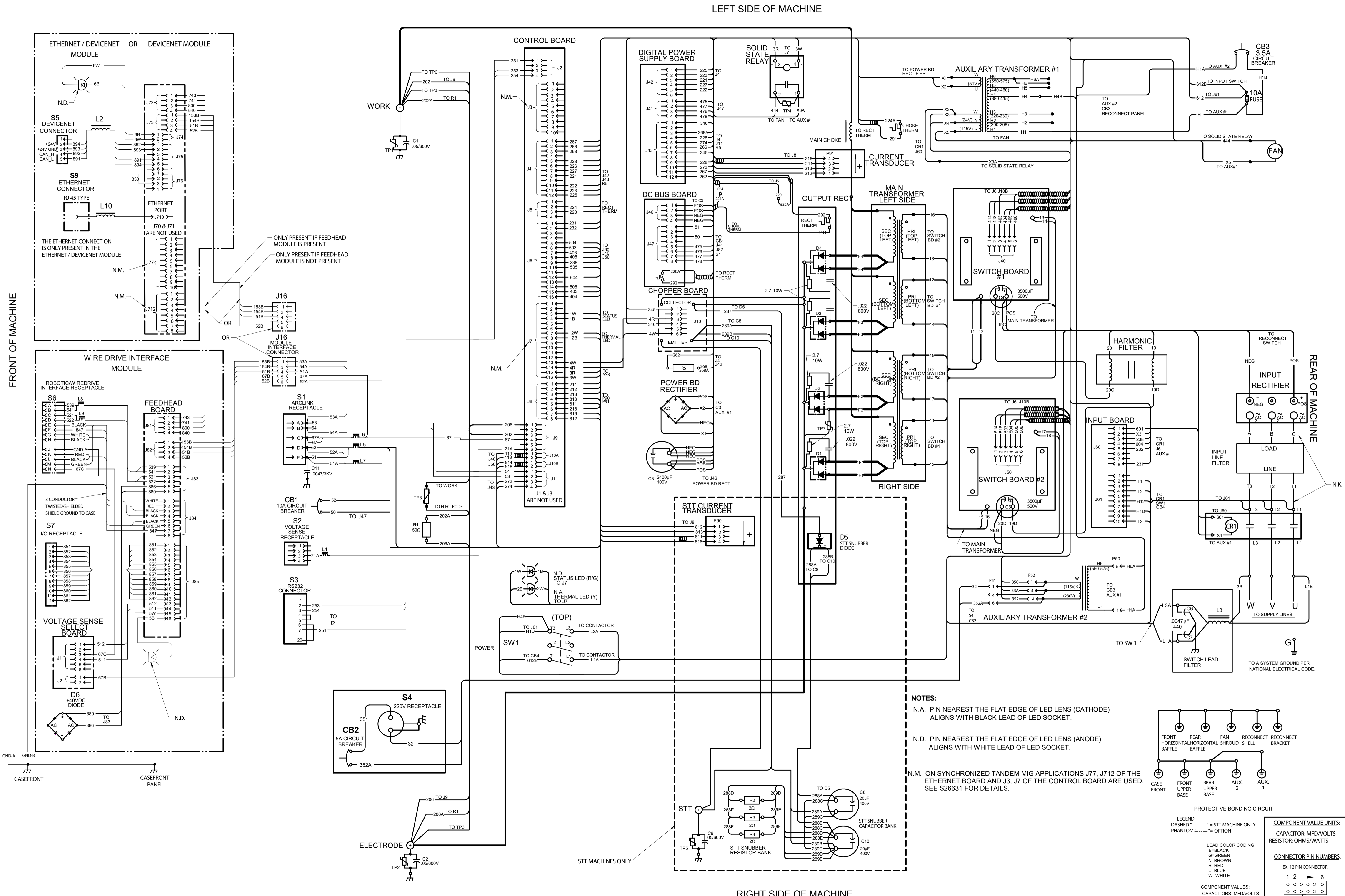

LEFT SIDE OF MACHINE

RIGHT SIDE OF MACHINE

NOTES:
 N.A. PIN NEAREST THE FLAT EDGE OF LED LENS (CATHODE) ALIGNS WITH BLACK LEAD OF LED SOCKET.
 N.D. PIN NEAREST THE FLAT EDGE OF LED LENS (ANODE) ALIGNS WITH WHITE LEAD OF LED SOCKET.
 N.M. ON SYNCHRONIZED TANDEM MIG APPLICATIONS J77, J712 OF THE ETHERNET BOARD AND J3, J7 OF THE CONTROL BOARD ARE USED. SEE S26631 FOR DETAILS.

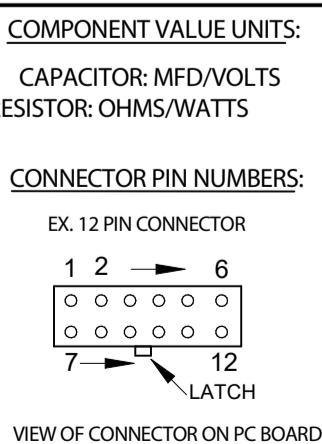
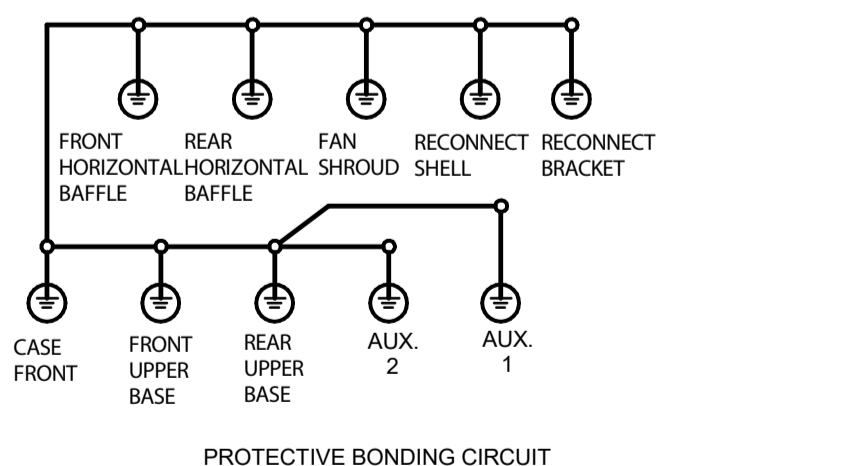

CLEVELAND, OHIO, U.S.A.