

POWERTEC 365S, 425S & 505S

Spare Parts.....	1
Figure A: Machine Assembly	2
Figure B: Machine Assembly	3
Figure C: Machine Assembly	4
Miscellaneous Items (not shown in figure A, B, C).....	4
Electrical Schematic.....	5
CODE: 50242, 50243, 50244.....	5



Spare Parts

SP50242, SP50243, SP50244 REV05
08/11

ASSEMBLY PAGE NAME			Machine Assembly	Machine Assembly	Machine Assembly	Miscellaneous Items		
CODE NO.:	K NO.:	FIGURE NO.:	A	B	C	-		
50242	K14061-2A	POWERTEC 365S	1	1	1	1		
50243	K14062-2A	POWERTEC 425S	2	2	2	2		
50244	K14063-2A	POWERTEC 505S	3	3	3	3		

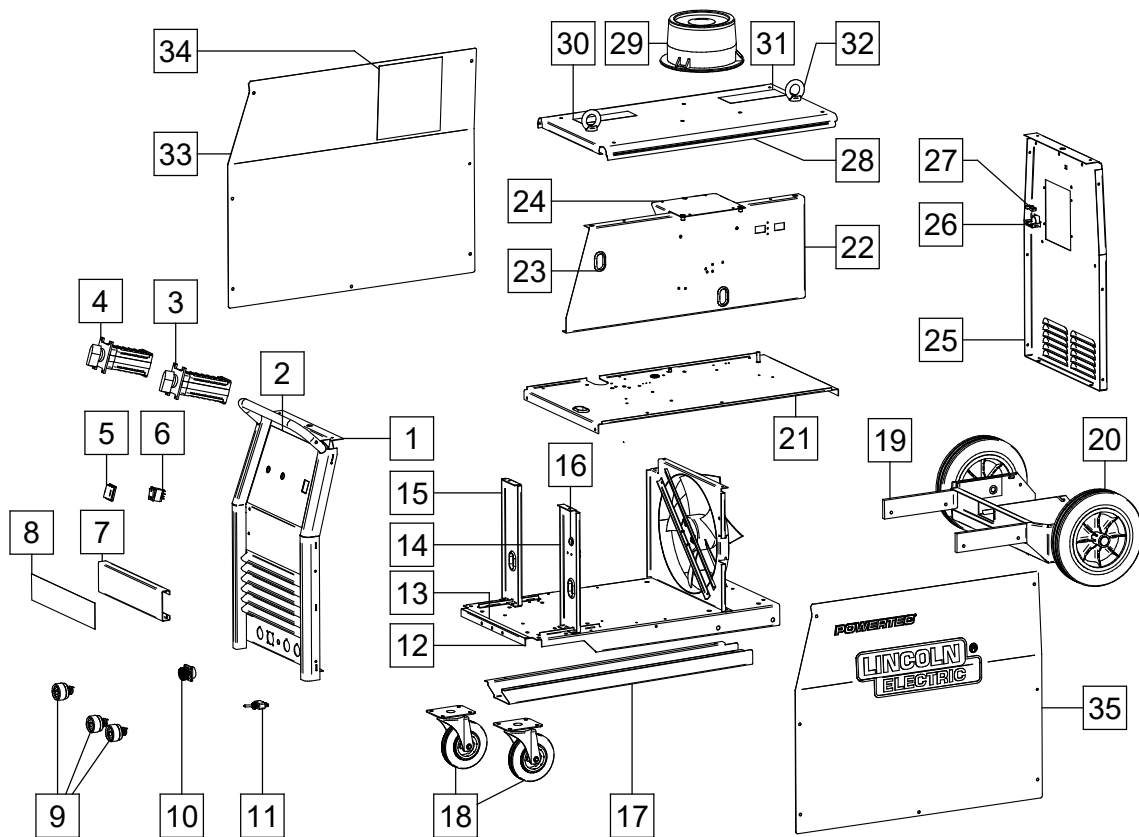

Figure A.

Figure A: Machine Assembly

Item	Description	Part Number	QTY	1	2	3	4	5	6	7
1	FRONT PANEL	R-3019-145-1/08R	1	X	X	X				
2	STICKER	R-0010-218-1R	1	X	X	X				
3	SWITCH S1	1115-260-074R	1	X	X					
	SWITCH S1	1115-260-224R	1			X				
4	SWITCH S2	1115-260-073R	1	X	X					
	SWITCH S2	1115-260-223R	1			X				
5	BLACK FLAME SHIELD	1115-299-073R	1	X	X	X				
6	SWITCH S3	1115-270-019R	1	X	X	X				
7	SHIELD	R-1019-161-1/02R	1	X	X	X				
8	STICKER	R-0010-234-1R	1	X						
	STICKER	R-0010-235-1R	1		X					
	STICKER	R-0010-236-1R	1			X				
9	SOCKET X2, X3, X4	C-2986-001-3R	3	X	X	X				
10	SOCKET X10	1158-641-130R	1	X	X	X				
11	SWITCH S4	1115-280-005R	1	X	X	X				
12	BASE	R-1019-150-1/08R	1	X	X	X				
13	STICKER	R-0010-238-1R	1	X	X	X				
14	BRACKET	R-1019-176-2/08R	1	X	X	X				
15	BRACKET	R-1019-176-1/08R	1	X	X	X				
16	RUBBER CABLE BUSH	1373-182-002R	3	X	X	X				
17	SUPPORT	R-1019-160-1/08R	1	X	X	X				
18	FRONT WHEELS	1029-660-127R	2	X	X	X				
19	SHELF	R-3019-026-1/08R	1	X	X	X				
20	REAR WHEELS	1029-660-250R	2	X	X	X				
21	SHELF	R-3019-142-1/08R	1	X	X	X				
22	DIVIDER	R-3019-143-1/08R	1	X	X	X				
23	RUBBER CABLE BUSH	1373-182-004R	5	X	X	X				
24	BRACKET	R-3019-093-1/08R	1	X	X	X				
25	REAR PANEL	R-3019-144-1/08R	1	X	X	X				
26	CABLE RELEIF	R-0010-258-1R	1	X	X	X				
27	CLAMP	1361-599-633R	1	X	X	X				
28	ROOF	R-1019-164-1/02R	1	X	X	X				
29	ROTARY BRACKET	1361-598-181R	1	X	X	X				
30	STICKER	2719-107-728R	1	X	X	X				
31	STICKER	R-0010-279-1R	1	X	X	X				
32	EYE BOLT	0653-313-012R	1	X	X	X				
33	LEFT SIDE PANEL	R-1019-180-1R	1	X	X	X				
34	STICKER (WIRING DIAGRAM)	R-0010-293-1R	1	X	X	X				
35	RIGHT SIDE APNEL	R-1019-182-1R	1	X	X	X				

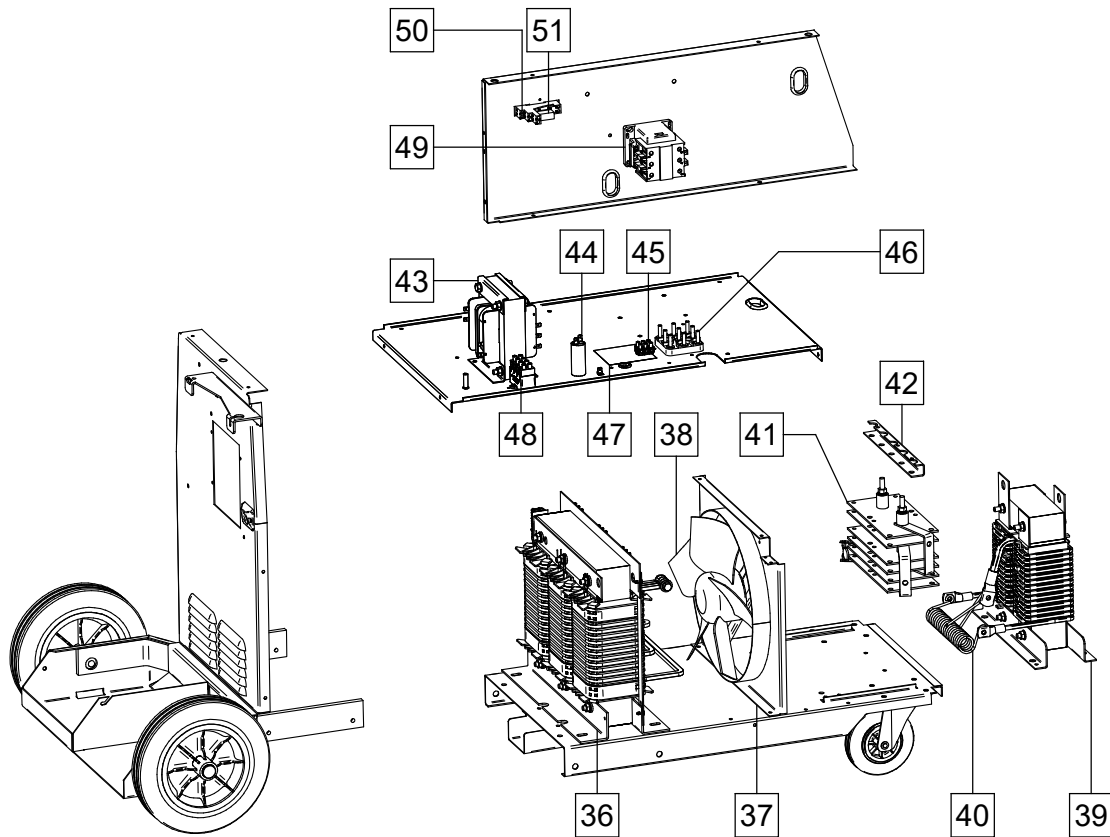

Figure B.

Figure B: Machine Assembly

Item	Description	Part Number	QTY	1	2	3	4	5	6	7
36	TRANSFORMER T1	R-4034-092-1R	1	X	-	-				
	TRANSFORMER T1	R-4034-093-1R	1	-	X	-				
	TRANSFORMER T1	R-4034-094-1R	1	-	-	X				
37	FAN BAFFLE	R-3019-135-1/08R	1	X	X	X				
38	FAN	R-8040-055-3R	1	X	X	X				
39	CHOKE L1	R-4034-091-1R	1	X	X	X				
	THERMAL SENSOR 140°C	1115-769-013R	1	X	X	X				
	THERMAL SENSOR 65°C	1115-769-053R	1	X	X	X				
40	RESISTORS R1, R2	R-2013-035-2R	2	X	X	X				
41	RECTIFIER V1	R-0010-241-1R	1	X	-	-				
	RECTIFIER V1	R-0010-242-1R	1	-	X	-				
	RECTIFIER V1	R-0010-243-1R	1	-	-	X				
	THERMAL SENSOR 115°C	1115-769-012R	1	X	X	X				
	THERMAL SENSOR 80°C	1115-769-003R	1	X	X	X				
42	BRACKET	R-1019-175-1/08R	1	X	X	X				
43	TRANSFORMER T2	C-4244-384-1R	1	X	X	X				
44	CAPACITOR C4	1158-121-001R	1	X	X	X				
45	TERMINAL BLOCK X7, X12	1131-990-005R	8	X	X	X				
46	TERMINAL BLOCK X6	0744-000-069R	1	X	X	X				
47	STICKER	R-0010-287-1R	1	X	X	X				
48	FILTER RC	0874-400-011R	1	X	X	X				
49	CONTACTOR K1	1115-212-242R	1	X	X	-				
	CONTACTOR K1	1115-212-243R	1	-	-	X				
50	RELAY'S BASE	1158-632-017R	1	X	X	X				
51	RELAY	0918-412-065R	1	X	X	X				

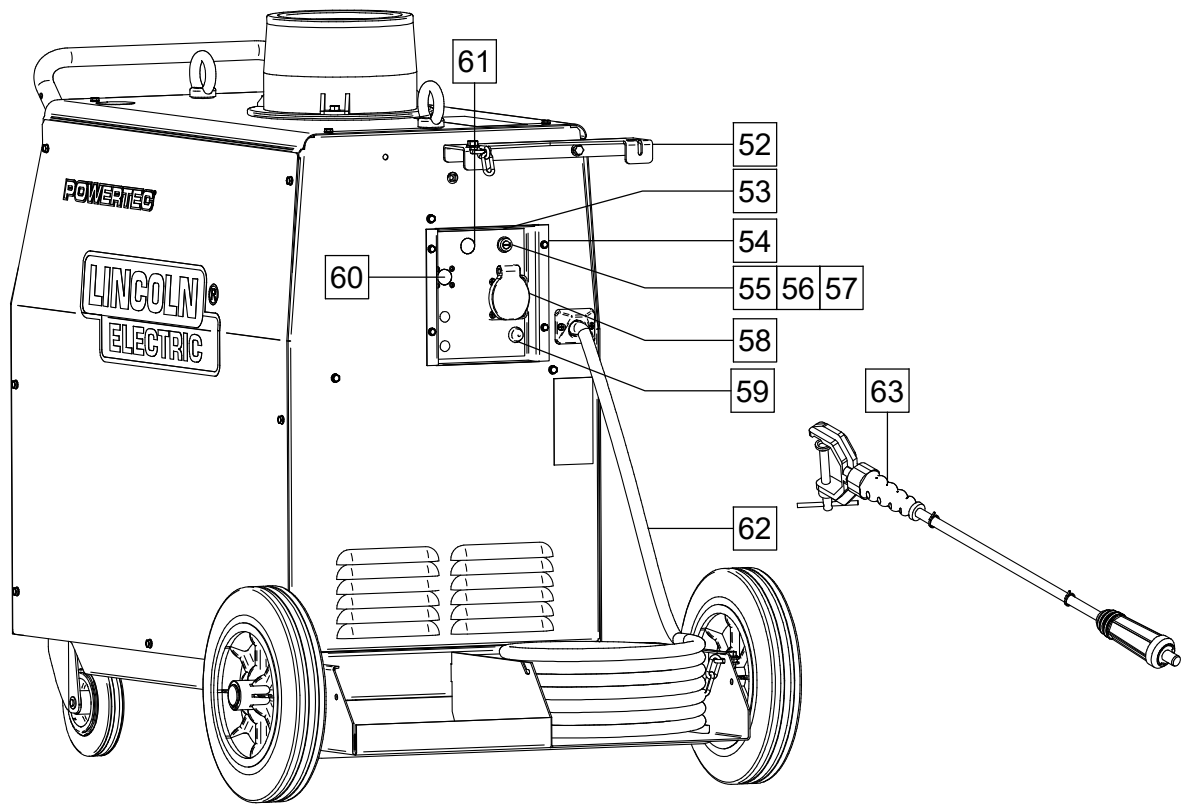

Figure C.

Figure C: Machine Assembly

Item	Description	Part Number	QTY	1	2	3	4	5	6	7
52	BRACKET	R-1019-153-1/08R	1	X	X	X				
53	STICKER	R-0010-239-1R	1	X	X	X				
54	PANEL	R-1019-157-1/08R	1	X	X	X				
55	FUSE HOLDER	1158-632-032R	1	X	X	X				
56	FUSE CAP	1158-632-033R	1	X	X	X				
57	FUSE F1 3A	1158-660-006R	1	X	X	X				
58	SOCKET X9	1131-222-004R	1	X	X	X				
59	THERMAL FUSE	1115-299-027R	1	X	X	X				
60	PLUG BUTTON	1361-599-058R	1	X	X	X				
61	PLUG BUTTON	1119-510-005R	1	X	X	X				
62	INPUT LEAD	D-5578-171-2R	1	X	-	-				
	INPUT LEAD	D-5578-171-3R	1		X	X				
63	WORK CABLE 3M	K14018-1	1	X	X	-				
	WORK CABLE 3M	K14033-1	1	-	-	X				

Miscellaneous Items (not shown in figure A, B, C)

Item	Description	Part Number	QTY	1	2	3	4	5	6	7
64	WIRING HARNESS A (PRIMARY)	R-5041-142-2R	1	X	X	X				
65	WIRING HARNESS B (PRIMARY)	R-5041-143-2R	1	X	X	X				
66	WIRING HARNESS (SECONDARY)	R-5041-159-1R	1	X	X	X				
67	WIRING HARNESS	R-5041-157-1R	1	X	X	X				

Electrical Schematic

CODE: 50242, 50243, 50244

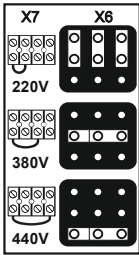
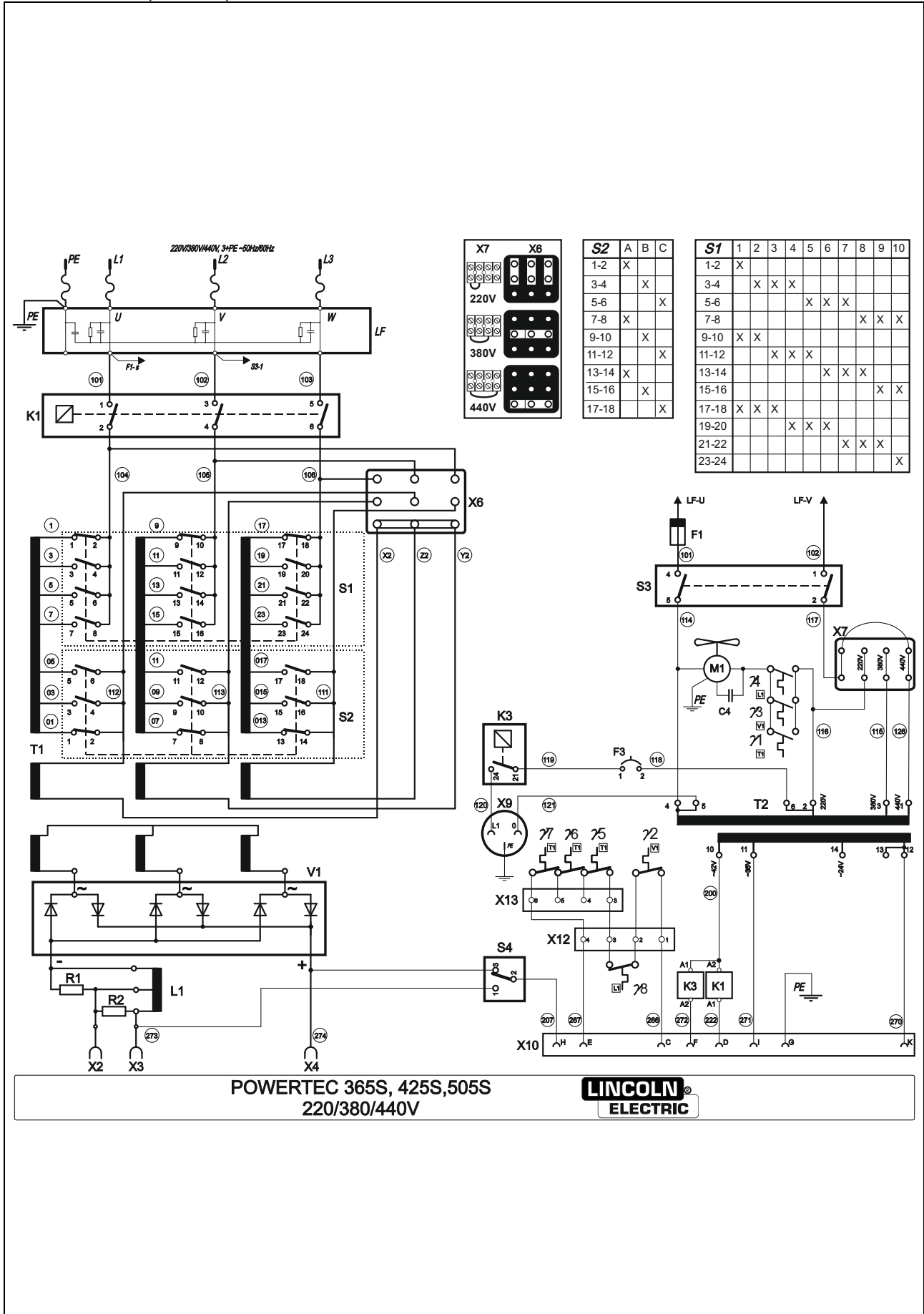

S2	A	B	C
1-2	X		
3-4		X	
5-6			X
7-8	X		
9-10		X	
11-12	X	X	
13-14			X
15-16	X		
17-18			X

S1	1	2	3	4	5	6	7	8	9	10
1-2	X									
3-4		X	X	X						
5-6					X	X	X			
7-8								X	X	X
9-10	X	X								
11-12			X	X	X					
13-14						X	X	X		
15-16									X	X
17-18	X	X	X							
19-20				X	X	X				
21-22							X	X	X	
23-24										X

POWERTEC 365S, 425S, 505S
220/380/440V



Connection Diagram

POWERTEC 365S 220/380/440V
K14061-2A

POWERTEC 425S 220/380/440V
K14062-2A

POWERTEC 505S 220/380/440V
K14063-2A

LF 22M : K14064-1
LF 24M : K14065-1W
LF 24M PRO : K14066-1W

CO2 SOCKET KIT:
K14009-1

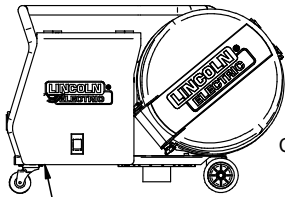

DRIVE ROLLS KIT:
KP14016-XX
KP14017-XX

8p
GAS
COOLANT

K10347-PGW-XXM
K10347-PG-XXM

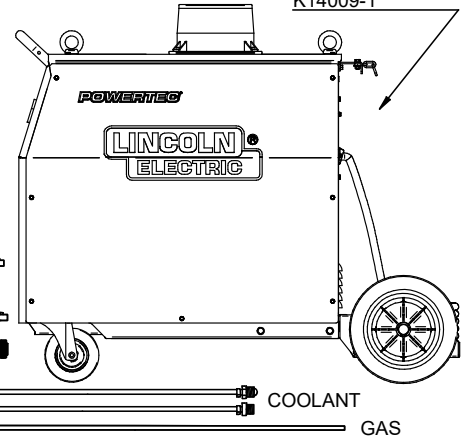

COOLANT
GAS

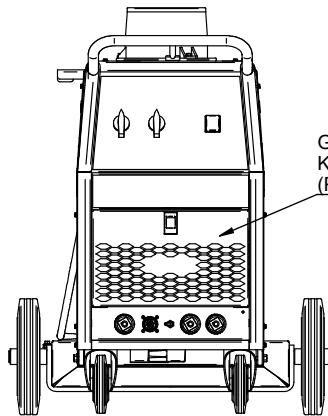

GRILL KIT:
K14071-2
(POWERTEC 365S, 425S, 505S)