

# MECHANIZED AUTOMATION SOLUTIONS

## SELECTION GUIDE

## The Mechanized Automation Advantage

The key is finding the right configuration of mechanized welding equipment – a single source supplier – and technical support over the lifespan of the system, who can also identify how you can make the task safer, faster and more cost-effective. A supplier needs to understand the production challenges and working conditions welders face in each application. They need to have the in-depth knowledge and first-hand expertise to recommend a solution that addresses the specific needs and expectations of a mechanized automated solution.

In the ever-evolving world of manufacturing, metal fabricators need to find innovative ways to stay competitive and meet demand while satisfying high standards and code requirements, from welding small process pipe to large pressure vessel, and penstock fabrication.

## PANTHEON® CB SOLUTIONS

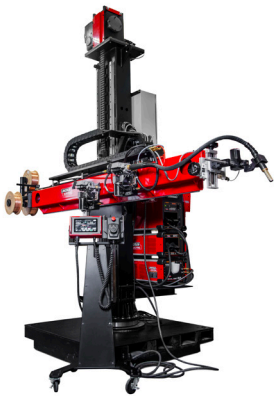

### Pantheon® CB-SD

Pantheon® Column and Boom - Standard Duty

#### SPECIFICATIONS

- Payload Capacity at End of Boom:
  - 150 kg @ 330 mm (330 lb. @ 12 in.)
- Available Stroke (V x H):
  - 6 ft. x 6 ft. (1.8 m x 1.8 m)
  - 10 ft. x 10 ft. (3.0 m x 3.0 m)

#### APPLICATIONS

- Single Wire SAW, GMAW or GTAW

#### PANTHEON® CB-SD-ADV UPGRADE

- The Pantheon® CB-SD can be paired with Pantheon HMI Controller to achieve single point of control for all included equipment.

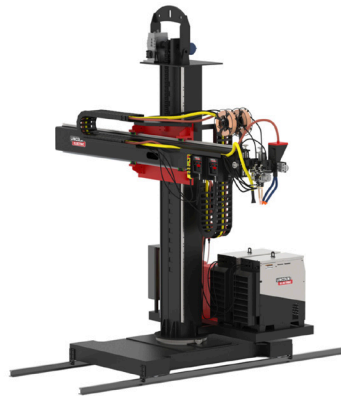

### Pantheon® CB-HD

Pantheon® Column and Boom - Heavy Duty

#### SPECIFICATIONS

- Payload Capacity at End of Boom:
  - 400 kg @ 330 mm (880 lb. @ 12 in.)
- Available Stroke (V x H):
  - 9.8 ft. x 9.8 ft. (3 m x 3 m)
  - 13.1 ft. x 13.1 ft. (4.0 m x 4.0 m)
  - 16.4 ft. x 16.4 ft. (5.0 m x 5.0 m)

#### APPLICATIONS

- Single or Dual Wire SAW, Tandem SAW, GMAW or GTAW

#### PANTHEON® CB-HD-ADV UPGRADE

- The Pantheon® CB-HD can be paired with Pantheon HMI Controller or Pilot Pro Controller to achieve single point of control for all included equipment as well as improved Tandem SAW control capabilities.

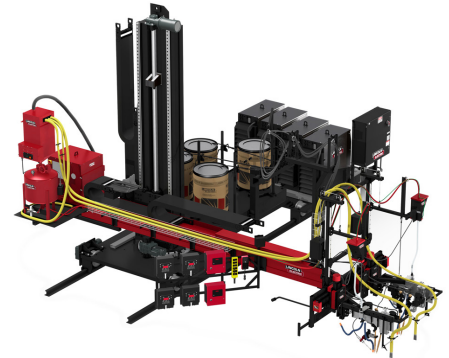

### Pantheon® CB-UD

Pantheon® Column and Boom - Ultra Duty

#### SPECIFICATIONS

- Payload Capacity at End of Boom\*:
  - 1,000 kg @ 330 mm (2,205 lb. @ 12 in.)
- Available Stroke (V x H):
  - 16.4 ft. x 16.4 ft. (5.0 m x 5.0 m) and above

#### APPLICATIONS

- Single or Dual Wire SAW, Tandem SAW, GMAW or GTAW

#### PANTHEON® CB-UD-ADV UPGRADE

- The Pantheon® CB-UD can be paired with Custom HMI Controller to improve overall system control. A custom-tailored solution can be designed as per the specific customer application.



# LATHES & SIDEBEAMS



## FEATURES

- Linear Bearings and Guideways for Rigidity and Smooth Operation
- VFD Controlled Carriage with Limit Switches for Precise Positioning
- Compact Footprint with Sufficient Beam Length for Parking of Carriage

## SPECIFICATIONS

- Various Single or Multi-Head Configurations Available
- Available in Various Stroke Lengths
- High Payload Capacity Carriage

## ACCESSORIES

- Positioning Equipment, Seam Tracking, Camera, and Flux Management

## APPLICATIONS

- Roller Overlay, Shaft/Journal Rebuilding, Pipe Assembly, Low-Profile Pressure Tank Head Joining and Assembly, Beam Welding
- SAW, MIG, FCAW, TIG Welding Processes

# GANTRIES



## FEATURES

- Robust Frame with Dual Weld Heads Tailored for Beam Welding
- Dual Synchronized Motors for Precise Motion During Welding

## SPECIFICATIONS

- Customizable Width and Lengths
- Multiple Head Configurations

## ACCESSORIES

- Seam Tracking, Camera, and Flux Management

## APPLICATIONS

- Structural Steel, Shipbuilding, I & H beams and Trailer Floor Manufacturing
- SAW, MIG, FCAW Welding Processes

# SEAMERS

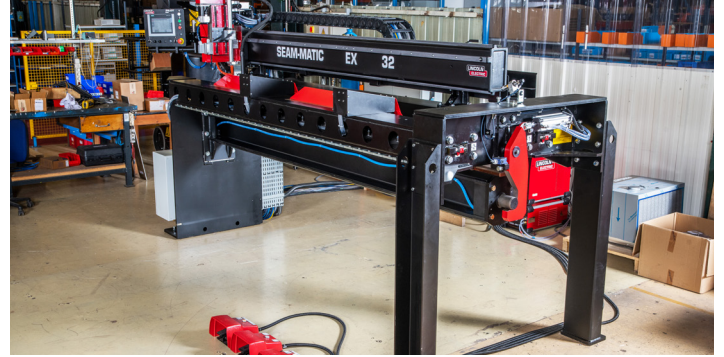

## FEATURES

- Specifically Designed for Highest Repeatability of Longitudinal Welding
- Seam Alignment Mechanisms for Ease of Operation
- Water Cooled Mandrel and Clamping Fingers to Minimize Heat Distortion

## SPECIFICATIONS

- Outer Diameter (OD)
  - From 24in to 216in seam length
  - From minimum 3.5in (ID) to 36in (OD)
- Inner Diameter (ID) / Flat Sheet (FS)
  - From 120in to 240in seam length
  - From minimum 50in (ID)
- Other custom configurations also available upon request

## ACCESSORIES

- Seam Tracking, Camera, and Flux Management

## APPLICATIONS

- General Pipe Welding, Pressure Vessels
- SAW, MIG, FCAW Welding Processes

# TRACTORS

## WELDY CAR 2.0 PRO

Portable welding carriage for MIG/MAG welding operations in all positions.



## CRUISER® SAW TRACTOR

The self propelled, modular Cruiser® travel carriage is perfect for lengthy butt and fillet joints.



# POSITIONING EQUIPMENT



## Turning Rolls

### SPECIFICATIONS

- Standard Payload Capacities Ranging from 1,500lb to 70,000lb
- Sets Include Drive and Idler Roller
- Rotation Direction Control (Fwd/Rev) and Speed Control through Potentiometer

### ACCESSORIES

- Foot Switch: Momentary On/Off, Variable Speed, or Forward/Reverse
- Idler or Motorized Rail Carts

### APPLICATIONS

- Pressure Vessels, Wind Towers, Tanks, Overlay



## Table Top & Floor Positioners

### SPECIFICATIONS

- Standard Payload Capacities Ranging from 150lb to 10,000lb
  - Table Top (150lb to 1,000lb) and Floor Mounted (1,000lb to 10,000lb) Units
- Manual Height Elevation Units Available

### ACCESSORIES

- Foot Switch: Momentary On/Off, Variable Speed, or Forward / Reverse
- Controller and Automation: Start Delay, Cycle Timer, and Digital Speed Display
- Spindle: Purge Hole and Material Pass Through
- Grippers and Chucks (6in to 60in)

### APPLICATIONS

- Mechanical Contractors, Pipe Welding/Spooling, Job Shops, Overlay



## Headstock & Tailstock

### SPECIFICATIONS

- Standard Payload Capacities Ranging from 1,000lb to 10,000lb
- Manual Height Elevation Units Available

### ACCESSORIES

- Foot Switch: Momentary On/Off, Variable Speed, or Forward / Reverse
- Controller and Automation: Start Delay, Cycle Timer, and Digital Speed Display
- Grippers and Chucks (6in to 60in)
- Idler or Motorized Rail Carts

### APPLICATIONS

- Pipe Welding, Pressure Vessels, Overlay



## Pipe Support Stands

### SPECIFICATIONS

- Standard Payload Capacities Ranging from 1,500lb to 4,000lb
- Manual Height Elevation Units Available
- Diameter Ranges from 2in to 48in

### ACCESSORIES

- Standard or V-Groove Casters (V-Rail Available)

### APPLICATIONS

- Mechanical Contractors, Pipe Welding/Spooling, Job Shops, Overlay

## RECOMMENDED ACCESSORIES

### Seam Tracking: Laser



Precision seam tracking for submerged arc, GMAW, FCAW and GTAW welding. System automatically adjusts the weld heads location to stay within the joint using a laser reading. More accurate than tactile system but requires a matte finish on parts.



### HMI Controller

The HMI Controllers (Pantheon HMI or Pilot Pro HMI) grant the operator the ability to control a systems manipulator, welding equipment, and turning equipment from a single ergonomic controller. Intuitive design makes personnel training and operation easier. Basic programs for welding out specific diameter pipe, straight lengths of welds and cladding operations allow operators more freedom during production. Different controllers will be recommended based on specific weld application.



### Flux Management Systems

Consistent flux feeding and cleaning help keep your welds covered minimizing flux and dust in your shop. Flux is recovered, filtered and returned back into the system, helping save on flux usage. Multiple sizes of tanks available.

### Seam Tracking: Tactile



Precision seam tracking for submerged arc, GMAW, FCAW and GTAW welding. System automatically adjusts the weld heads location to stay within the joint using a tactile probe. Different seam tracking heads available to match different weld geometries.

### Remote Viewing Cameras

Remote viewing submerged arc welding camera is a durable, heat protected camera that will allow clear viewing of welds during operation. For hard to reach joints like large diameter pipes and inside small diameter this will mean less operator strain and improved safety.



## CUSTOMER ASSISTANCE POLICY

The business of Lincoln Electric is manufacturing and selling high quality welding equipment, automated welding systems, consumables, and cutting equipment. Our challenge is to meet the needs of our customers, who are experts in their fields, and to exceed their expectations. On occasion, purchasers may ask Lincoln Electric for information or technical information about their use of our products. Our employees respond to inquiries to the best of their ability based on information and specifications provided to them by the customers and the knowledge they may have concerning the application. Our employees, however, are not in a position to verify the information provided or to evaluate the engineering requirements for the particular weldment, or to provide engineering advice in relation to a specific situation. Accordingly, Lincoln Electric does not warrant or guarantee or assume any liability with respect to such information or communications. Moreover, the provision of such information or technical information does not create, expand, or alter any warranty on our products. Any express or implied warranty that might arise from the information or technical information, including any implied warranty of merchantability or any warranty of fitness for any customers' particular purpose or any other equivalent or similar warranty is specifically disclaimed.

Lincoln Electric is a responsive manufacturer, but the definition of specifications, and the selection and use of specific products sold by Lincoln Electric is solely within the control of, and remains the sole responsibility of the customer. Many variables beyond the control of Lincoln Electric affect the results obtained in applying these types of fabrication methods and service requirements.

Subject to Change – This information is accurate to the best of our knowledge at the time of printing. Please refer to [www.lincolnelectric.com](http://www.lincolnelectric.com) for any updated information. All trademarks and registered trademarks are the property of their respective owners.

<https://lered.info/Mechanized-Automation>

**Lincoln Electric Automation**  
939 Gana Court · Mississauga · ON · L5S 1N9 · Canada  
905.565.5600  
[www.lincolnelectric.com](http://www.lincolnelectric.com)