

WE'VE GOT YOUR BACK™

**GAS APPARATUS EQUIPMENT
FOR FABRICATORS, DEMOLITION,
FOUNDRIES, SCRAP & RECYCLING
INDUSTRIES**



A LINCOLN ELECTRIC COMPANY

62-5 CUTTING TORCHES



MODEL 62-5AFL-48" SHOWN

48"

CUTS 12" LISTED

FEATURES

- ▶ Triangular tube design
- ▶ Brazed connections
- ▶ Solid forged head, tail and lever
- ▶ Equipped with FlashGuard® check valves

PART NUMBER	MODEL NUMBER	HEAD ANGLE	TORCH LENGTH	RECOMMENDED TIP SERIES
1003480	62-5FL-36	90°	36"	<p>6290-NX 6290-NXP 6290-NFF 6290-5NH 6290-6NH 6290-7NH See page 9 for tip charts</p>
1003400	62-5AFL-36	70°	36"	
1003426	62-5BFL-36	180°	36"	
1003481	62-5FL-48	90°	48"	
1003411	62-5AFL-48	70°	48"	
1003421	62-5BFL-48	180°	48"	

Additional lengths / head configurations available through customer service.
Tips sold separately.

HEAD ANGLE

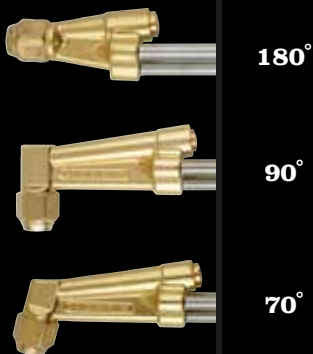

ACCESSORIES



70°/90° SKID
PN: QC1HZSTK2



180° SLITTING SKID
PN: QC1HZSTK5

1 YR WARRANTY

PROFESSIONAL TOOLS... SUPERIOR RESULTS

62-5SS CUTTING TORCHES



MODEL 62-5SSAF-48" SHOWN

48"

CUTS 14"

FEATURES

- ▶ Triangular tube design
- ▶ Brazed connections
- ▶ Solid forged head, tail and lever
- ▶ Equipped with FlashGuard® check valves
- ▶ Unique full-length aircraft aluminum handle casing for comfort and added rigidity

[Ⓢ] PART NUMBER	MODEL NUMBER	HEAD ANGLE	TORCH LENGTH	RECOMMENDED TIP SERIES
QC1003550	625-SSAFLBLK-36	70°	36"	<p>6290-NX 6290-NXP 6290-NFF 6290-NH See page 9 for tip charts</p>
QC1003551	625-SSAFLBLK-48	70°	48"	
QC1003552	625-SSBFLBLK-48	180°	48"	
QC1003554	625-SSFLBLK-36	90°	36"	
QC1003555	625-SSFLBLK-48	90°	48"	
QC1003553	625-SSBFLBLK-36	180°	36"	

Additional lengths / head configurations available through special order.
Tips sold separately.

ACCESSORIES



70°/90° SKID
PN: QC1HZSTK2

[Ⓢ] [Ⓢ]



180° SLITTING SKID
PN: QC1HZSTK5

[Ⓢ]



70°/90°/180° TUBE GUARD
PN: QC1WHP625031P

136 CUTTING TORCHES



CUTS 36"

FEATURES

- ▶ Stainless steel head and tubes
- ▶ Triangular tube design
- ▶ Tip mix torch for propane, natural gas and propylene
- ▶ Requires 3/8" hose on oxygen and fuel gas
- ▶ Internal tip nut

Ⓢ

PART NUMBER	MODEL NUMBER	HEAD ANGLE	TORCH LENGTH	RECOMMENDED TIPS	
				PN	136 SERIES
QC136236	136-2-36	90°	36"	QC13611	136-11
QC136248	136-2-48	90°	48"	QC13613	136-13
QC136260	136-2-60	90°	60"	QC13615	136-15
QC1362A36	136-2A-36	75°	36"	QC14009	140-09
QC1362A48	136-2A-48	75°	48"	QC14011	140-11
QC1362A60	136-2A-60	75°	60"	QC14012	140-12
QC1362B36	136-2B-36	180°	36"	QC14013	140-13
QC1362B48	136-2B-48	180°	48"		
QC1362B60	136-2B-60	180°	60"		

Additional lengths and head configurations available through special order. Tips sold separately.

Fits 136, 136TK & 136HDTK



Series 136 Heavy Hand Cutting Tips

- ▶ Captive nut
- ▶ Heavy shell with shroud
- ▶ "U" spline standard preheat



Series 140 Heavy Hand Cutting Tips

- ▶ Non-captive nut (P/N 1WHP136-01P)
- ▶ Non-shrouded
- ▶ "V" spline heavy preheat



Series 140HS Heavy High Speed Hand Cutting Tips

- ▶ Non-captive nut (P/N 1WHP136-01P)
- ▶ Non-shrouded
- ▶ "U" spline heavy preheat

See page 10 - 11 for tip charts

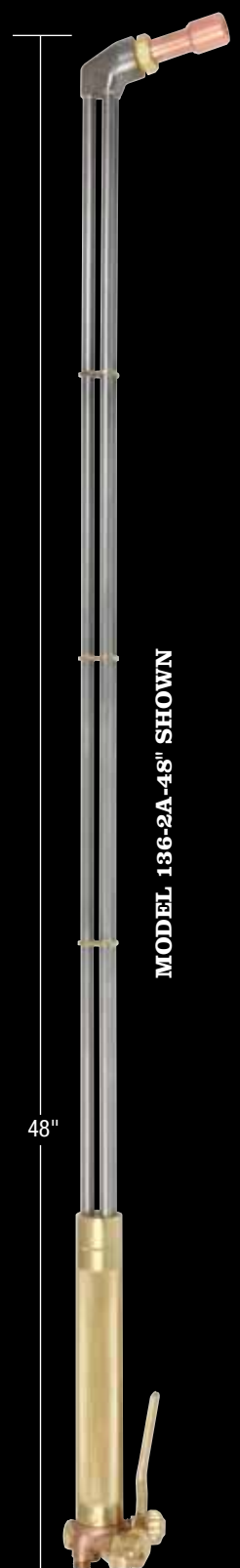

MODEL 136-2A-48" SHOWN

48"

Available only for Model 136 torches with welded head bracket option. Call customer service for details.

ACCESSORIES

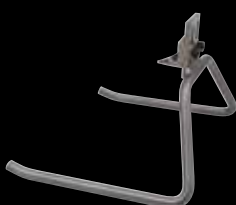

75°/90° SKID
PN: QC1HZSTK1



180° SLITTING SKID
PN: QC1HZSTK6

1 YR WARRANTY

PROFESSIONAL TOOLS... SUPERIOR RESULTS

136TK & 136HDTK CUTTING TORCHES



CUTS 36"

FEATURES

- ▶ Stainless steel head and tubes
- ▶ Triangular tube design
- ▶ Tip mix torch for propane or natural gas
- ▶ Requires 3/8" I.D. hose
- ▶ Internal tip nut
- ▶ Unique full-length aircraft aluminum handle casing for comfort and added rigidity
- ▶ 136HDTK is available in 2 & 3 hose configurations

③ PART NUMBER	MODEL NUMBER	HEAD ANGLE	TORCH LENGTH
QC1362AHDTK48	136-2AHDTK-48	75°	48"
QC1362AHDTK60	136-2AHDTK-60	75°	60"
QC1362ATK36	136-2ATK-36	75°	36"
QC1362ATK48	136-2ATK-48	75°	48"
QC1362ATK60	136-2ATK-60	75°	60"
QC1362BHDTK48	136-2BHDTK-48	180°	48"
QC1362BHDTK60	136-2BHDTK-60	180°	60"
QC1362BTK36	136-2BTK-36	180°	36"
QC1362BTK48	136-2BTK-48	180°	48"
QC1362BTK60	136-2BTK-60	180°	60"
QC1362HDTK48	136-2HDTK-48	90°	48"
QC1362HDTK60	136-2HDTK-60	90°	60"
QC1362TK36	136-2TK-36	90°	36"
QC1362TK48	136-2TK-48	90°	48"
QC1362TK60	136-2TK-60	90°	60"

Additional lengths and head configurations available through special order. 136HDTK requires a 1/2" I.D. oxygen hose. Tips sold separately.

See page 10 - 11 for tip charts

ACCESSORIES

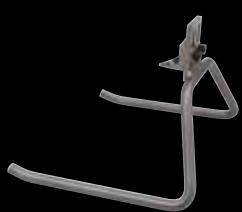

75°/90° SKID
PN: QC1HZSTK1



180° SLITTING SKID
PN: QC1HZSTK6



TUBE GUARD
70°/90° PN: QC1WHP13629P
180° PN: QC1HP13628P

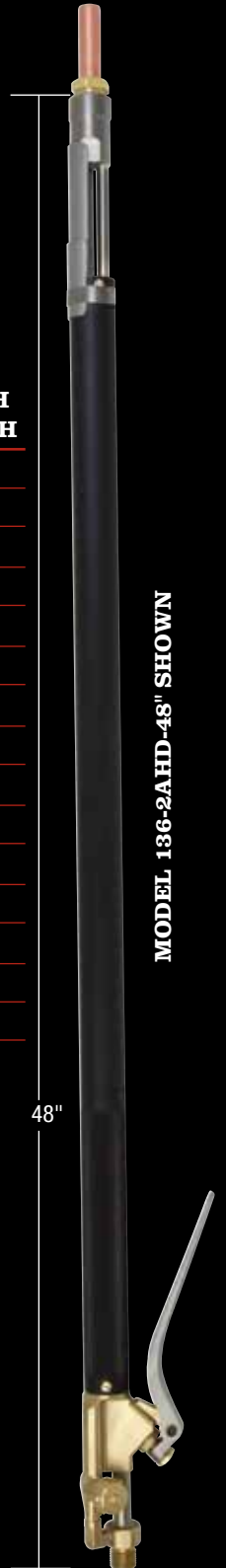

MODEL 136-2AHD-48" SHOWN

48"

6000 CUTTING TORCHES



CUTS 50"

FEATURES

- ▶ Triangular tube design
- ▶ Brazed connections
- ▶ Solid forged head, tail and lever
- ▶ Stainless steel head and tubes
- ▶ Tip mix design
- ▶ Available in 2 or 3 hose configuration
- ▶ Top rear lever standard

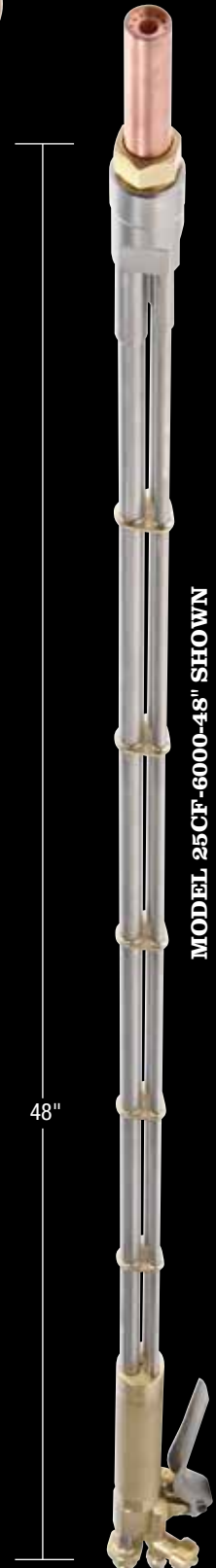

MODEL 25 CF-6000-48" SHOWN

48"

[®] PART NUMBER	MODEL NUMBER	HEAD ANGLE	TORCH LENGTH	RECOMMENDED TIPS												
QC2SCF6000036	2SCF6000-036	180°	36"	213 SERIES QC2SCT213-10 QC2SCT213-15S QC2SCT213-20S												
QC2SCF6000048	2SCF6000-048	180°	48"													
QC2SCF6000060	2SCF6000-060	180°	60"													
QC2SCF6075036	2SCF6075-036	75°	36"	RECOMMENDED HOSE <table border="1"> <thead> <tr> <th>Gas Type</th> <th>Hose Size</th> <th>Connection</th> </tr> </thead> <tbody> <tr> <td>OXYGEN</td> <td>1/2" I.D.</td> <td>"C" RH</td> </tr> <tr> <td>FUEL GAS</td> <td>3/8" I.D.</td> <td>"B" LH</td> </tr> <tr> <td>*OXYGEN</td> <td>3/8" I.D.</td> <td>"B" RH</td> </tr> </tbody> </table> *Pre heat for three hose torches.	Gas Type	Hose Size	Connection	OXYGEN	1/2" I.D.	"C" RH	FUEL GAS	3/8" I.D.	"B" LH	*OXYGEN	3/8" I.D.	"B" RH
Gas Type	Hose Size	Connection														
OXYGEN	1/2" I.D.	"C" RH														
FUEL GAS	3/8" I.D.	"B" LH														
*OXYGEN	3/8" I.D.	"B" RH														
QC2SCF6075048	2SCF6075-048	75°	48"													
QC2SCF6075060	2SCF6075-060	75°	60"													
QC2SCF6090036	2SCF6090-036	90°	36"													
QC2SCF6090048	2SCF6090-048	90°	48"													
QC2SCF6090060	2SCF6090-060	90°	60"													

Additional lengths / head configurations available through special order.
 Tips sold separately.

See page 11 for tip charts

ACCESSORIES

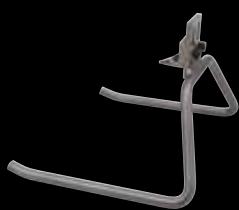

75°/90° SKID
 PN: QC2SCA2

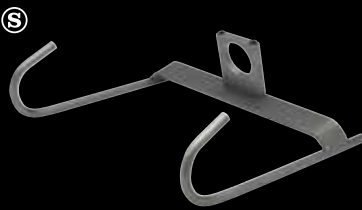

180° SLITTING SKID
 PN: QC2SCA7

1 YR WARRANTY

PROFESSIONAL TOOLS... SUPERIOR RESULTS

6000TK CUTTING TORCHES



CUTS 50"

FEATURES

- ▶ Triangular tube design
- ▶ Brazed connections
- ▶ Solid forged head, tail and lever
- ▶ Stainless Steel head and tubes
- ▶ Tip mix design
- ▶ Available in 2 or 3 hose configuration
- ▶ Unique full-length aircraft aluminum handle casing for comfort and added rigidity
- ▶ Bottom rear lever standard



MODEL 25CF-6000TK-48" SHOWN

48"

PART NUMBER	MODEL NUMBER	HEAD ANGLE	TORCH LENGTH	RECOMMENDED TIPS
QC2SCF6000TK036	2SCF6000TK-036	180°	36"	213 SERIES QC2SCT213-10 QC2SCT213-15S QC2SCT213-20S
QC2SCF6000TK048	2SCF6000TK-048	180°	48"	
QC2SCF6000TK060	2SCF6000TK-060	180°	60"	
QC2SCF6075TK036	2SCF6075TK-036	75°	36"	RECOMMENDED HOSE Gas Type Hose Size Connection OXYGEN 1/2" I.D. "C" RH FUEL GAS 3/8" I.D. "B" LH *OXYGEN 3/8" I.D. "B" RH *Pre heat for three hose torches.
QC2SCF6075TK048	2SCF6075TK-048	75°	48"	
QC2SCF6075TK060	2SCF6075TK-060	75°	60"	
QC2SCF6090TK036	2SCF6090TK-036	90°	36"	
QC2SCF6090TK048	2SCF6090TK-048	90°	48"	
QC2SCF6090TK060	2SCF6090TK-060	90°	60"	

Additional lengths / head configurations available through special order.
 Tips sold separately.

See page 11 for tip charts

ACCESSORIES

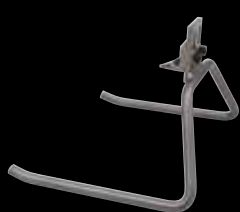

75°/90° SKID
 PN: QC2SCA2

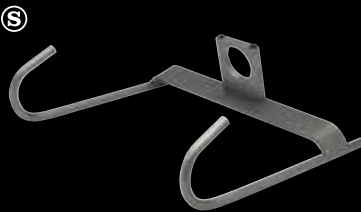

180° SLITTING SKID
 PN: QC2SCA7



70°/90°/180° TUBE GUARD
 PN: QC2SCA3

IRON FERNO®

IRON POWDER CUTTING TORCH

**CUTS STAINLESS
STEEL & OTHER
NON-FERROUS
MATERIAL**

TORCH FEATURES

- ▶ Multi jet powder head
 - Better performance and durability
 - Easy to clean and maintain
 - Cuts in all directions
- ▶ For propane and other alternate fuel gases
- ▶ Iron Powder facilitates cutting of metals which are difficult or impossible to cut with oxy-fuel alone

HOPPER FEATURES

- ▶ Premium, industrial grade product
- ▶ Innovative design for maximum portability and safety
- ▶ Regulator with encapsulated seat to control pressure
- ▶ Brass, stainless and painted steel construction
- ▶ Relief valve to protect from over pressurization
- ▶ Up to 30% greater efficiency than other brands



Ironator

Regulator

Relief Valve

Bleeder Valve

©
STARTER KIT PN: QC4404900
(INCLUDES THE FOLLOWING)

DESCRIPTION	REPLACEMENT PART NO.
POWDER-TORCH, 4900-A LENGTH 48" - HEAD 75°	QC1004904
DISPENSER W/CART, 100LB PORTABLE IRON	QC4304900
HOSE- ASY, 50' NITROGEN SUPPLY	QC4304906
HOSE- ASY, 1/4" - 3/8" X 50' TRI-HOSE	QC4304905
CUT-TIP, 229-8 (8" capacity)	QC1502581
CUT-TIP, 229-10 (10" capacity)	QC1502582
CUT-TIP, 229-12 (12" capacity)	QC1502583
REG, 450-200-540	3002499
REG, 450-50-510P	3002495
REG, 450-125-580	3002498
BUSHING, BRS REDUCING 1/2" NPTM X 1/4" N	9005806
NIPPLE-OUTLET, 957-R	9000194
KIT, CGA 540 TO 1/4" NPTF X 1/2" NPTM ADAP	9103615
MANUAL, IRON FERNO	9504102
MANUAL, TRILINGUAL KIT	9505643

PART NO.	DESCRIPTION
QC4304903	50lb IRON POWDER
Sold separately.	

Additional lengths and head configurations available. Tips and iron powder sold separately.
See page 11 for tip charts

6290 CUTTING TIPS

FOR MODELS 62-5 & 62-5SS



6290N & NX - PROPANE / NATURAL GAS GENERAL PREHEAT 2-PIECE CUTTING TIPS

PART NUMBER	MODEL NUMBER	DEPTH OF CUT	OXYGEN PSIG	OXYGEN FLOW SCFH	FUEL PSIG	FUEL FLOW	DRILL SIZE
1501230	1NX	5/8"-1"	35-50	100-135	4oz - 2lb	8.7	56
1501240	2NX	1"-2"	40-55	200-250	4oz - 2lb	10	52
1501250	3NX	2"-3"	45-60	290-365	4oz - 2lb	10	48
1501260	4NX	3"-6"	50-70	475-625	4oz - 2lb	12.5	42
1501270	5NX	6"-8"	65-80	710-860	4oz - 2lb	15	35
1501280	6NX	8"-12"	70-90	970-1100	4oz - 2lb	17.5	30



6290NFF - PROPANE / NATURAL GAS HEAVY PREHEAT 2-PIECE CUTTING TIPS

PART NUMBER	MODEL NUMBER	DEPTH OF CUT	OXYGEN PSIG	OXYGEN FLOW SCFH	FUEL PSIG	FUEL FLOW	DRILL SIZE
1501020	1NFF	TO 5/8"	20-35	115-140	4oz - 2lb	17.5	56
1501030	2NFF	5/8"-2"	30-55	170-230	4oz - 2lb	17.5	53
1501040	3NFF	2"-4"	45-65	355-420	4oz - 2lb	17.5	47
1501050	4NFF	4"-7"	55-75	520-645	4oz - 2lb	17.5	42
1501060	5NFF	7"-10"	60-80	660-870	4oz - 2lb	17.5	35
1501070	6NFF	10"-11"	80-90	870-1020	4oz - 2lb	17.5	31
1501080	7NFF	12"-13"	80-90	1050-1205	4oz - 2lb	17.5	30



6290NXP - PROPYLENE GENERAL PREHEAT 2-PIECE CUTTING TIPS

PART NUMBER	MODEL NUMBER	DEPTH OF CUT	OXYGEN PSIG	OXYGEN FLOW SCFH	FUEL PSIG	FUEL FLOW	DRILL SIZE
1502156	1NXP	5/8"-1"	35-50	75-100	4oz - 2lb	11.5	56
1502158	2NXP	1"-2"	40-55	160-210	4oz - 2lb	11.5	52
1502160	3NXP	2"-3"	45-60	250-325	4oz - 2lb	11.5	48
1502162	4NXP	3"-6"	50-75	425-575	4oz - 2lb	11.5	42
1502164	5NXP	6"-8"	65-80	650-800	4oz - 2lb	11.5	35
1502166	6NXP	8"-12"	70-90	900-1100	4oz - 2lb	11.5	30

6290 CUTTING TIPS

FOR MODELS 62-5 & 62-5SS



6290NH - PROPANE / NATURAL GAS 2-PIECE CUTTING TIPS

PART NUMBER	MODEL NUMBER	DEPTH OF CUT	OXYGEN PSIG	PRE HEAT FUEL PSIG	OXYGEN CONSUMPTION SCFH	PROPANE CONSUMPTION SCFH
1501120	5NH	10"	60	4oz - 2lb	700	20
1501130	6NH	11"	60	4oz - 2lb	790	20
1501140	7NH	12"	60	4oz - 2lb	925	20
1501190	8NH	15"	60	4oz - 2lb	1025	20

NOTE: Not for use with acetylene. NH tips are not plated, have a course pre-heat, and a heavy shell

136 CUTTING TIPS

FOR MODELS 136, 136TK & 136HDTK



136 - PROPANE / NATURAL GAS HEAVY HAND CUTTING TIPS

③ PART NUMBER	MODEL NUMBER	DEPTH OF CUT	OXYGEN PSIG	OXYGEN FLOW SCFH	FUEL PSIG	FUEL FLOW	DRILL SIZE
QC13611	136-11	12"-19"	60-80	950-2900	8-15	130-350	3/16"
QC13613	136-13	19"-28"	60-80	2100-4000	10-15	150-400	1/4"
QC13615	136-15	28"-36"	80-100	2500-4500	15-20	180-450	11/32"

NOTE: Not for use with acetylene. Features a heavy shell with shroud, captive nut and standard preheat.

140 CUTTING TIPS

FOR MODELS 136, 136TK & 136HDTK



140 - PROPANE / NATURAL GAS HEAVY HAND CUTTING TIPS

③ PART NUMBER	MODEL NUMBER	DEPTH OF CUT	OXYGEN PSIG	OXYGEN FLOW SCFH	FUEL PSIG	FUEL FLOW	DRILL SIZE
QC14009	140-09	15"	65-85	1300-1500	12-15	100-120	5/32"
QC14011	140-11	19"	65-85	1700-1950	12-15	130-160	3/16"
QC14012	140-12	20"	65-85	1800-2250	12-15	165-180	7/32"
QC14013	140-13	25"	65-85	2100-2500	15-18	175-210	1/4"

NOTE: Not for use with acetylene. A low cost, straight bore tip with heavy preheat.

140HS CUTTING TIPS

FOR MODELS 136, 136TK & 136HDTK



140HS - PROPANE / NATURAL GAS HEAVY, HIGH SPEED HAND CUTTING TIPS

Ⓢ

PART NUMBER	MODEL NUMBER	DEPTH OF CUT	OXYGEN PSIG	OXYGEN FLOW SCFH	FUEL PSIG	FUEL FLOW
QC140160	140-160	15"	90-130	2100-2300	12-15	100-120
QC140200	140-200	19"	90-130	3100-3500	12-15	130-160
QC140240	140-240	25"	90-130	4600-5100	12-15	165-180

NOTE: Not for use with acetylene.

Features a divergent bore, "U" spline with standard preheat for high speed heavy cutting.

213 CUTTING TIPS

FOR MODEL 6000



213 - PROPANE / NATURAL GAS / PROPYLENE HEAVY HAND CUTTING TIPS

Ⓢ

PART NUMBER	MODEL NUMBER	DEPTH OF CUT	OXYGEN PSIG	OXYGEN FLOW SCFH	FUEL PSIG	FUEL FLOW
QC2SCT21310	2SCT21310	20"-40"	80-120	4000-5500	15-20	130-350
QC2SCT21315S	2SCT21315S	40"-50"	80-120	5000-6500	15-20	150-400
QC2SCT21320S	2SCT21320S	* OVER 50"	80-120	6000-8000	15-20	180-450

NOTE: Not for use with acetylene.

* 3 hose torch option recommended for cutting over 50"

229 CUTTING TIPS

IRON POWDER



229 - PROPANE / NATURAL GAS / PROPYLENE HEAVY HAND CUTTING TIPS

Ⓢ

PART NUMBER	MODEL NUMBER	DEPTH OF CUT	OXYGEN PSIG	OXYGEN FLOW SCFH	FUEL PSIG	FUEL FLOW
QC1502580	229-6	6"	55-65	600	8-10	35
QC1502581	229-8	8"	60-70	900	9-11	42
QC1502582	229-10	10"	65-75	1350	10-13	47
QC1502583	229-12	12"	70-85	1950	12-15	52

NOTE: Not for use with acetylene.



450 HEAVY DUTY REGULATOR

With stainless steel diaphragm



The Harris Model 450 is an economically priced heavy duty regulator specifically designed for use in the most abusive working conditions in both shop and field.

- ▶ One-piece encapsulated seat design with an internal filter and a PTFE teflon seat
- ▶ Brass bonnet and bronze adjusting screw
- ▶ 2-1/2" dual scale gauges
- ▶ Conforms to CGA E-4
- ▶ Can be used for gaseous withdrawal from liquid cylinders
- ▶ Tamper proof, self reseating, internal HP safety valve

PART NO.	MODEL NO.	GAS	MAXIMUM INLET PSIG	DELIVERY PRESSURE RANGE PSIG	DELIVERY PRESSURE GAUGE PSIG	SUPPLY PRESSURE GAUGE PSIG	INLET CONNECTION	OUTLET CONNECTION
3002495	450-50-510P	LPG	500	0-50	100	400	CGA 510P	9/16"-18LH
3002498	450-125-580	Ar, He, N2	3000	0-125	200	4000	CGA 580	5/8"-18RH
3002496	450-50-540	OXYGEN	3000	0-50	100	4000	CGA 540	9/16"-18RH
3002497	450-125-540	OXYGEN	3000	0-125	200	4000	CGA 540	9/16"-18RH
3002499	450-200-540	OXYGEN	3000	0-200	400	4000	CGA 540	9/16"-18RH

NOTE: Available for other gases and additional pressure ranges - Call customer service



425 SINGLE STAGE REGULATOR

The Model 425 is an ideal choice for most heavy duty industrial applications. The Model 425 is a long lasting rugged performer.

- ▶ Tamper proof, self reseating internal HP safety valve
- ▶ One-piece encapsulated seat design with an internal filter and a PTFE teflon seat
- ▶ Bronze adjusting screw for smooth adjusting
- ▶ 2-1/2" dual scale gauges
- ▶ Brass bonnet and body
- ▶ UL Listed and conforms to CGA E-4



PART NO.	MODEL NO.	GAS	MAXIMUM INLET PSIG	DELIVERY PRESSURE RANGE PSIG	DELIVERY PRESSURE GAUGE PSIG	SUPPLY PRESSURE GAUGE PSIG	INLET CONNECTION	OUTLET CONNECTION
3000767	425-125-580	NITROGEN	3000	0-125	200	4000	CGA 580	9/16"-18RH
3000714	425-125-540	OXYGEN	3000	0-125	200	4000	CGA 540	9/16"-18RH
3000796	425-200-540	OXYGEN	3000	0-200	400	4000	CGA 540	9/16"-18RH
3000713	425-50-510P	LPG	3000	0-50	60	400	CGA 510P	9/16"-18LH

NOTE: Available for other gases and additional pressure ranges - Call customer service



3YR WARRANTY

PROFESSIONAL TOOLS... SUPERIOR RESULTS

330 LIQUID CYLINDER REGULATOR

With stainless steel diaphragm



The Model 330 regulator allows for gaseous withdrawal from oxygen, carbon dioxide, argon and nitrogen liquid cylinders.

- ▶ 2-3/4" stainless steel diaphragm
- ▶ PTFE teflon seals and seats
- ▶ One-piece encapsulated seat design with an internal filter
- ▶ Tamper proof, self seating internal H.P. safety valve
- ▶ Designed specifically to operate on liquid cylinders but can be used on high pressure cylinders without damage
- ▶ UL Listed and certified to CGA E4



PART NO.	MODEL NO.	GAS	MAXIMUM INLET PSIG	DELIVERY PRESSURE RANGE PSIG	DELIVERY PRESSURE GAUGE PSIG	INLET CONNECTION	OUTLET CONNECTION
3001090	330-125-540	OXYGEN	3000	0-125	200	CGA 540	9/16"-18RH
3001093	330-350-540	OXYGEN	3000	0-350	500	CGA 540	9/16"-18RH
3001091	330-125-580	Ar, He, N ₂	3000	0-125	200	CGA 580	9/16"-18LH
3001094	330-350-580	Ar, He, N ₂	3000	0-350	500	CGA 580	9/16"-18LH

NOTE: Available for other gases and additional pressure ranges - Call customer service

88-5 FBHR FLASH-GUARD®



Flashback Arrestors For High Flow Applications



FEATURES

- ▶ Prevents reverse flow of gases with built-in check valves
- ▶ Extinguishes flashback fire with stainless steel sintered element
- ▶ 100 micron inlet filter helps keep dust and dirt out
- ▶ Thermal shut-off which positively shuts off the gas in case of hose fire, burn back or repeated flashbacks

For use with Harris models 62-5 and 62-5SS up to a maximum cutting capacity of 12". For cutting capacities in excess of 12" please contact customer service.

PN: 4301652 - OXYGEN
PN: 4301655 - FUEL GAS
 SOLD SEPARATELY

1 YR WARRANTY

88-5 FBR FLASH-GUARD®



Regulator Mounted Flashback Arrestors



FEATURES

- ▶ Prevents reverse flow of gases with built-in check valves
- ▶ Extinguishes flashback fire with stainless steel sintered element
- ▶ 100 micron inlet filter helps keep dust and dirt out

For use with Harris models 62-5 and 62-5SS up to a maximum cutting capacity of 8". For cutting capacities in excess of 8" please contact customer service.

PN: 4302203
 SOLD IN PAIRS

1 YR WARRANTY

88-5 FBT FLASH-GUARD®



Torch Mounted Flashback Arrestors



FEATURES

- ▶ Prevents reverse flow of gases with built-in check valves
- ▶ Extinguishes flashback fire with stainless steel sintered element
- ▶ 100 micron inlet filter helps keep dust and dirt out

For use with Harris models 62-5 and 62-5SS up to a maximum cutting capacity of 8". For cutting capacities in excess of 8" please contact customer service.

PN: 4302202
 SOLD IN PAIRS

1 YR WARRANTY

PROFESSIONAL TOOLS... SUPERIOR RESULTS

8530 & 147 DRY FLASHBACK ARRESTOR

Pipeline Protection Device

BAM/ZBA/003/04 APPROVED



Harris Pipeline Protection Devices incorporate dry type flashback arrestors, ASME relief valves and check valves in their design. They are designed to meet requirements of NFPA 51 in fuel gas piping systems. Unlike hydraulic flash arrestors, dry arrestors are maintenance free, do not require fluid and provide continuous safe operation in fuel gas distribution systems.

- ▶ High surface area stainless steel flash arrestor material extinguishes flashback
- ▶ Temperature sensitive shut-off valve extinguishes sustained flashbacks
- ▶ Spring loaded check valve prevents reverse flow from forming explosive mixtures in the gas supply
- ▶ Can be mounted in any position

PART NO.	MODEL NO.	GAS	FLOW CAPACITY (AIR)	INLET/OUTLET	RELIEF VALVE
4300223	8530-FG-1"	LPG, NATURAL GAS, H ₂	1000 SCFH	1" NPT	40 PSI
4300224	8530-FG-1/2"	LPG, NATURAL GAS, H ₂	1000 SCFH	1/2" NPT	40 PSI
4300228	147-OX-1"	OXYGEN	5000 SCFH	1" NPT	225 PSI
4300229	147-OX-1/2"	OXYGEN	5000 SCFH	1/2" NPT	225 PSI

1 YR WARRANTY

LOW PRESSURE / HIGH FLOW PIPELINE PARTICLE FILTERS FOR OXYGEN, FUEL AND INERT GASES

Removes dirt, scale and other particulate matter that can damage critical downstream components such as flash arrestors, regulators, solenoid valves and torches etc.. Features an easily replaceable 60 micron sintered bronze filter element.

- ▶ T style design allows filter replacement without removal from piping
- ▶ Low initial pressure drop with a capacity of up to 25,000 SCFH air
- ▶ Pressure rating of up to 350psi
- ▶ Can be mounted in a vertical or horizontal position

Ⓢ PART NO.	GAS	INLET/VALVE	CAPACITY
QC2HLF2560	FUEL	1" NPT(F)	25,000 SCFH (Air)
QC2HLF2580	OXYGEN / INERT	1" NPT(F)	25,000 SCFH (Air)
QC9HLF2600	REPLACEMENT FILTER CARTRIDGE		



Ⓢ Denotes a HARRIS "SPECIAL ORDER" product. For more details see Harris Terms and Conditions of Sale or contact Harris Customer Service.



A LINCOLN ELECTRIC COMPANY

THE HARRIS PRODUCTS GROUP
A LINCOLN ELECTRIC COMPANY
2345 MURPHY BLVD.
GAINESVILLE, GA 30504
1.800.241.0804
www.harrisproductsgroup.com

PN: 9502736
052012