

AC-225-GLM WELDING POWER SOURCE

by



IM347
April, 1998

This manual covers equipment which is obsolete and no longer in production by The Lincoln Electric Co. Specifications and availability of optional features may have changed.

Welder's Guide

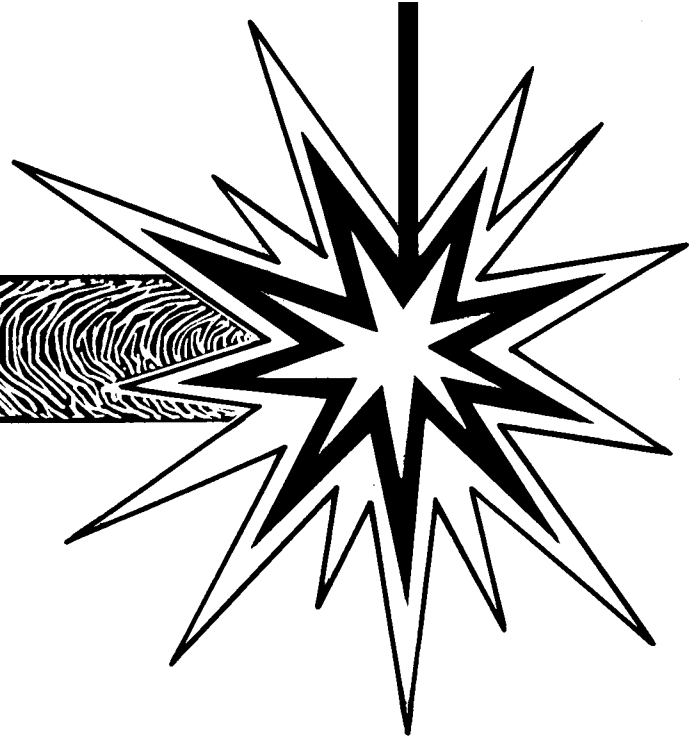

Safety Depends on You

Lincoln arc welding and cutting equipment is designed and built with safety in mind. However, your overall safety can be increased by proper installation ... and thoughtful operation on your part. **DO NOT INSTALL, OPERATE OR REPAIR THIS EQUIPMENT WITHOUT READING THIS MANUAL AND THE SAFETY PRECAUTIONS CONTAINED THROUGHOUT.** And, most importantly, think before you act and be careful.

Contents

	Page
Safety Precautions	2
Installation and Operating Instructions for AC-225-GLM Dual Voltage Type (K1327).....	7
Includes safety, installation, operating instructions and parts lists.	
Learning to Weld	9
Using the Carbon Arc Torch.....	17
Includes for heating metal, welding aluminum or brazing with an arc torch.	
Selecting Electrodes	19
Welding Books and Teaching Aids	23



World's Leader in Welding and Cutting Products Premier Manufacturer of Industrial Motors

• Sales and Service through Subsidiaries and Distributors Worldwide •

Cleveland, Ohio 44117-1199 U.S.A. TEL: 216.481.8100 FAX: 216.486.1751 WEB SITE: www.lincolnelectric.com

SAFETY

WARNING

CALIFORNIA PROPOSITION 65 WARNINGS

Diesel engine exhaust and some of its constituents are known to the State of California to cause cancer, birth defects, and other reproductive harm.

The Above For Diesel Engines

The engine exhaust from this product contains chemicals known to the State of California to cause cancer, birth defects, or other reproductive harm.

The Above For Gasoline Engines

ARC WELDING CAN BE HAZARDOUS. PROTECT YOURSELF AND OTHERS FROM POSSIBLE SERIOUS INJURY OR DEATH. KEEP CHILDREN AWAY. PACEMAKER WEARERS SHOULD CONSULT WITH THEIR DOCTOR BEFORE OPERATING.

Read and understand the following safety highlights. For additional safety information, it is strongly recommended that you purchase a copy of "Safety in Welding & Cutting - ANSI Standard Z49.1" from the American Welding Society, P.O. Box 351040, Miami, Florida 33135 or CSA Standard W117.2-1974. A Free copy of "Arc Welding Safety" booklet E205 is available from the Lincoln Electric Company, 22801 St. Clair Avenue, Cleveland, Ohio 44117-1199.

BE SURE THAT ALL INSTALLATION, OPERATION, MAINTENANCE AND REPAIR PROCEDURES ARE PERFORMED ONLY BY QUALIFIED INDIVIDUALS.



FOR ENGINE powered equipment.

1.a. Turn the engine off before troubleshooting and maintenance work unless the maintenance work requires it to be running.



1.b. Operate engines in open, well-ventilated areas or vent the engine exhaust fumes outdoors.



1.c. Do not add the fuel near an open flame welding arc or when the engine is running. Stop the engine and allow it to cool before refueling to prevent spilled fuel from vaporizing on contact with hot engine parts and igniting. Do not spill fuel when filling tank. If fuel is spilled, wipe it up and do not start engine until fumes have been eliminated.

1.d. Keep all equipment safety guards, covers and devices in position and in good repair. Keep hands, hair, clothing and tools away from V-belts, gears, fans and all other moving parts when starting, operating or repairing equipment.

1.e. In some cases it may be necessary to remove safety guards to perform required maintenance. Remove guards only when necessary and replace them when the maintenance requiring their removal is complete. Always use the greatest care when working near moving parts.



1.f. Do not put your hands near the engine fan. Do not attempt to override the governor or idler by pushing on the throttle control rods while the engine is running.

1.g. To prevent accidentally starting gasoline engines while turning the engine or welding generator during maintenance work, disconnect the spark plug wires, distributor cap or magneto wire as appropriate.



1.h. To avoid scalding, do not remove the radiator pressure cap when the engine is hot.



ELECTRIC AND MAGNETIC FIELDS may be dangerous

2.a. Electric current flowing through any conductor causes localized Electric and Magnetic Fields (EMF). Welding current creates EMF fields around welding cables and welding machines

2.b. EMF fields may interfere with some pacemakers, and welders having a pacemaker should consult their physician before welding.

2.c. Exposure to EMF fields in welding may have other health effects which are now not known.

2.d. All welders should use the following procedures in order to minimize exposure to EMF fields from the welding circuit:

2.d.1. Route the electrode and work cables together - Secure them with tape when possible.

2.d.2. Never coil the electrode lead around your body.

2.d.3. Do not place your body between the electrode and work cables. If the electrode cable is on your right side, the work cable should also be on your right side.

2.d.4. Connect the work cable to the workpiece as close as possible to the area being welded.

2.d.5. Do not work next to welding power source.

Mar '95

SAFETY



ELECTRIC SHOCK can kill.

3.a. The electrode and work (or ground) circuits are electrically "hot" when the welder is on. Do not touch these "hot" parts with your bare skin or wet clothing. Wear dry, hole-free gloves to insulate hands.

3.b. Insulate yourself from work and ground using dry insulation. Make certain the insulation is large enough to cover your full area of physical contact with work and ground.

In addition to the normal safety precautions, if welding must be performed under electrically hazardous conditions (in damp locations or while wearing wet clothing; on metal structures such as floors, gratings or scaffolds; when in cramped positions such as sitting, kneeling or lying, if there is a high risk of unavoidable or accidental contact with the workpiece or ground) use the following equipment:

- Semiautomatic DC Constant Voltage (Wire) Welder.
- DC Manual (Stick) Welder.
- AC Welder with Reduced Voltage Control.

3.c. In semiautomatic or automatic wire welding, the electrode, electrode reel, welding head, nozzle or semiautomatic welding gun are also electrically "hot".

3.d. Always be sure the work cable makes a good electrical connection with the metal being welded. The connection should be as close as possible to the area being welded.

3.e. Ground the work or metal to be welded to a good electrical (earth) ground.

3.f. Maintain the electrode holder, work clamp, welding cable and welding machine in good, safe operating condition. Replace damaged insulation.

3.g. Never dip the electrode in water for cooling.

3.h. Never simultaneously touch electrically "hot" parts of electrode holders connected to two welders because voltage between the two can be the total of the open circuit voltage of both welders.

3.i. When working above floor level, use a safety belt to protect yourself from a fall should you get a shock.

3.j. Also see Items 6.c. and 8.



ARC RAYS can burn.

4.a. Use a shield with the proper filter and cover plates to protect your eyes from sparks and the rays of the arc when welding or observing open arc welding. Headshield and filter lens should conform to ANSI Z87.1 standards.

4.b. Use suitable clothing made from durable flame-resistant material to protect your skin and that of your helpers from the arc rays.

4.c. Protect other nearby personnel with suitable, non-flammable screening and/or warn them not to watch the arc nor expose themselves to the arc rays or to hot spatter or metal.



FUMES AND GASES can be dangerous.

5.a. Welding may produce fumes and gases hazardous to health. Avoid breathing these fumes and gases. When welding, keep your head out of the fume. Use enough ventilation and/or exhaust at the arc to keep

fumes and gases away from the breathing zone. **When welding with electrodes which require special ventilation such as stainless or hard facing (see instructions on container or MSDS) or on lead or cadmium plated steel and other metals or coatings which produce highly toxic fumes, keep exposure as low as possible and below Threshold Limit Values (TLV) using local exhaust or mechanical ventilation. In confined spaces or in some circumstances, outdoors, a respirator may be required. Additional precautions are also required when welding on galvanized steel.**

5.b. Do not weld in locations near chlorinated hydrocarbon vapors coming from degreasing, cleaning or spraying operations. The heat and rays of the arc can react with solvent vapors to form phosgene, a highly toxic gas, and other irritating products.

5.c. Shielding gases used for arc welding can displace air and cause injury or death. Always use enough ventilation, especially in confined areas, to insure breathing air is safe.

5.d. Read and understand the manufacturer's instructions for this equipment and the consumables to be used, including the material safety data sheet (MSDS) and follow your employer's safety practices. MSDS forms are available from your welding distributor or from the manufacturer.

5.e. Also see item 1.b.

Mar '95

SAFETY

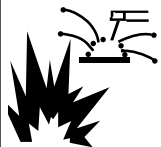

WELDING SPARKS can cause fire or explosion.

6.a. Remove fire hazards from the welding area. If this is not possible, cover them to prevent the welding sparks from starting a fire. Remember that welding sparks and hot

materials from welding can easily go through small cracks and openings to adjacent areas. Avoid welding near hydraulic lines. Have a fire extinguisher readily available.

6.b. Where compressed gases are to be used at the job site, special precautions should be used to prevent hazardous situations. Refer to "Safety in Welding and Cutting" (ANSI Standard Z49.1) and the operating information for the equipment being used.

6.c. When not welding, make certain no part of the electrode circuit is touching the work or ground. Accidental contact can cause overheating and create a fire hazard.

6.d. Do not heat, cut or weld tanks, drums or containers until the proper steps have been taken to insure that such procedures will not cause flammable or toxic vapors from substances inside. They can cause an explosion even though they have been "cleaned". For information, purchase "Recommended Safe Practices for the Preparation for Welding and Cutting of Containers and Piping That Have Held Hazardous Substances", AWS F4.1 from the American Welding Society (see address above).

6.e. Vent hollow castings or containers before heating, cutting or welding. They may explode.

6.f. Sparks and spatter are thrown from the welding arc. Wear oil free protective garments such as leather gloves, heavy shirt, cuffless trousers, high shoes and a cap over your hair. Wear ear plugs when welding out of position or in confined places. Always wear safety glasses with side shields when in a welding area.

6.g. Connect the work cable to the work as close to the welding area as practical. Work cables connected to the building framework or other locations away from the welding area increase the possibility of the welding current passing through lifting chains, crane cables or other alternate circuits. This can create fire hazards or overheat lifting chains or cables until they fail.

6.h. Also see item 1.c.

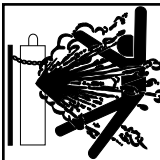

CYLINDER may explode if damaged.

7.a. Use only compressed gas cylinders containing the correct shielding gas for the process used and properly operating regulators designed for the gas and pressure used. All hoses, fittings, etc. should be suitable for the application and maintained in good condition.

7.b. Always keep cylinders in an upright position securely chained to an undercarriage or fixed support.

7.c. Cylinders should be located:
• Away from areas where they may be struck or subjected to physical damage.

• A safe distance from arc welding or cutting operations and any other source of heat, sparks, or flame.

7.d. Never allow the electrode, electrode holder or any other electrically "hot" parts to touch a cylinder.

7.e. Keep your head and face away from the cylinder valve outlet when opening the cylinder valve.

7.f. Valve protection caps should always be in place and hand tight except when the cylinder is in use or connected for use.

7.g. Read and follow the instructions on compressed gas cylinders, associated equipment, and CGA publication P-1, "Precautions for Safe Handling of Compressed Gases in Cylinders," available from the Compressed Gas Association 1235 Jefferson Davis Highway, Arlington, VA 22202.



FOR ELECTRICALLY powered equipment.

8.a. Turn off input power using the disconnect switch at the fuse box before working on the equipment.

8.b. Install equipment in accordance with the U.S. National Electrical Code, all local codes and the manufacturer's recommendations.

8.c. Ground the equipment in accordance with the U.S. National Electrical Code and the manufacturer's recommendations.

Mar '95

PRÉCAUTIONS DE SÛRETÉ

Pour votre propre protection lire et observer toutes les instructions et les précautions de sûreté spécifiques qui paraissent dans ce manuel aussi bien que les précautions de sûreté générales suivantes:

Sûreté Pour Soudage A L'Arc

1. Protégez-vous contre la secousse électrique:
 - a. Les circuits à l'électrode et à la pièce sont sous tension quand la machine à souder est en marche. Eviter toujours tout contact entre les parties sous tension et la peau nue ou les vêtements mouillés. Porter des gants secs et sans trous pour isoler les mains.
 - b. Faire très attention de bien s'isoler de la masse quand on soude dans des endroits humides, ou sur un plancher métallique ou des grilles métalliques, principalement dans les positions assis ou couché pour lesquelles une grande partie du corps peut être en contact avec la masse.
 - c. Maintenir le porte-électrode, la pince de masse, le câble de soudage et la machine à souder en bon et sûr état de fonctionnement.
 - d. Ne jamais plonger le porte-électrode dans l'eau pour le refroidir.
 - e. Ne jamais toucher simultanément les parties sous tension des porte-électrodes connectés à deux machines à souder parce que la tension entre les deux pinces peut être le total de la tension à vide des deux machines.
 - f. Si on utilise la machine à souder comme une source de courant pour soudage semi-automatique, ces précautions pour le porte-électrode s'appliquent aussi au pistolet de soudage.
2. Dans le cas de travail au dessus du niveau du sol, se protéger contre les chutes dans le cas où on reçoit un choc. Ne jamais enrouler le câble-électrode autour de n'importe quelle partie du corps.
3. Un coup d'arc peut être plus sévère qu'un coup de soleil, donc:
 - a. Utiliser un bon masque avec un verre filtrant approprié ainsi qu'un verre blanc afin de se protéger les yeux du rayonnement de l'arc et des projections quand on soude ou quand on regarde l'arc.
 - b. Porter des vêtements convenables afin de protéger la peau de soudeur et des aides contre le rayonnement de l'arc.
 - c. Protéger l'autre personnel travaillant à proximité au soudage à l'aide d'écrans appropriés et non-inflammables.
4. Des gouttes de laitier en fusion sont émises de l'arc de soudage. Se protéger avec des vêtements de protection libres de l'huile, tels que les gants en cuir, chemise épaisse, pantalons sans revers, et chaussures montantes.
5. Toujours porter des lunettes de sécurité dans la zone de soudage. Utiliser des lunettes avec écrans latéraux dans les zones où l'on pique le laitier.
6. Eloigner les matériaux inflammables ou les recouvrir afin de prévenir tout risque d'incendie dû aux étincelles.
7. Quand on ne soude pas, poser la pince à un endroit isolé de la masse. Un court-circuit accidentel peut provoquer un échauffement et un risque d'incendie.
8. S'assurer que la masse est connectée le plus près possible de la zone de travail qu'il est pratique de le faire. Si on place la masse sur la charpente de la construction ou d'autres endroits éloignés de la zone de travail, on augmente le risque de voir passer le courant de soudage par les chaînes de levage, câbles de grue, ou autres circuits. Cela peut provoquer des risques d'incendie ou d'échauffement des chaînes et des câbles jusqu'à ce qu'ils se rompent.
9. Assurer une ventilation suffisante dans la zone de soudage. Ceci est particulièrement important pour le soudage de tôles galvanisées plombées, ou cadmiées ou tout autre métal qui produit des fumées toxiques.
10. Ne pas souder en présence de vapeurs de chlore provenant d'opérations de dégraissage, nettoyage ou pistolage. La chaleur ou les rayons de l'arc peuvent réagir avec les vapeurs du solvant pour produire du phosgène (gas fortement toxique) ou autres produits irritants.
11. Pour obtenir de plus amples renseignements sur la sûreté, voir le code "Code for safety in welding and cutting" CSA Standard W 117.2-1974.

PRÉCAUTIONS DE SÛRETÉ POUR LES MACHINES À SOUDER À TRANSFORMATEUR ET À REDRESSEUR

1. Relier à la terre le châssis du poste conformément au code de l'électricité et aux recommandations du fabricant. Le dispositif de montage ou la pièce à souder doit être branché à une bonne mise à la terre.
2. Autant que possible, l'installation et l'entretien du poste seront effectués par un électricien qualifié.
3. Avant de faire des travaux à l'intérieur de poste, la débrancher à l'interrupteur à la boîte de fusibles.
4. Garder tous les couvercles et dispositifs de sûreté à leur place.

Mar. '93

Thank You

for selecting a **QUALITY** product by Lincoln Electric. We want you to take pride in operating this Lincoln Electric Company product ... as much pride as we have in bringing this product to you!

Please Examine Carton and Equipment For Damage Immediately

When this equipment is shipped, title passes to the purchaser upon receipt by the carrier. Consequently, Claims for material damaged in shipment must be made by the purchaser against the transportation company at the time the shipment is received.

Please record your equipment identification information below for future reference. This information can be found on your machine nameplate.

Model Name & Number _____

Code & Serial Number _____

Date of Purchase _____

Whenever you request replacement parts for or information on this equipment always supply the information you have recorded above.

Read this Operators Manual completely before attempting to use this equipment. Save this manual and keep it handy for quick reference. Pay particular attention to the safety instructions we have provided for your protection. The level of seriousness to be applied to each is explained below:

⚠ WARNING

This statement appears where the information **must** be followed **exactly** to avoid **serious personal injury** or **loss of life**.

⚠ CAUTION

This statement appears where the information **must** be followed to avoid **minor personal injury** or **damage to this equipment**.

OPERATING INSTRUCTIONS

Input Power and Grounding Connections

Before starting the installation, check with the power company to be sure your power supply is adequate for the voltage, amperes, phase and frequency specified on the welder nameplate. Also, be sure the planned installation will meet the National Electrical Code and all local code requirements. This welder may be operated from a single phase line or from one phase of a two or three phase line.

The unit is shipped with a five foot length input cable only. No plug or receptacle is supplied from the factory.

Place the welder so there is free circulation of air in through the louvers in the back and sides of the case and out of the bottom on all four sides.

⚠ WARNING

These installation instructions apply to the input wiring and overload protection installed to supply one AC-225-GLM and comply with the United States National Electrical Code as it applies to electric welders. Other equipment should not be connected to this supply without consulting the input power requirements for that equipment, the United States National Electrical Code, and all local codes.

⚠ WARNING

Only qualified personnel should make the input power connections. Turn the input power off at the disconnect switch before attempting to connect the input power lines to the welder.

Using the following instructions, have a qualified electrician connect the unit to a fuse box or disconnect switch. For 60 Hz. operation use 50 Amp Superlag Fuses. For 50 Hz. operation use 60 Amp Superlag Fuses. Fuse the two hot lines of the circuit. A green wire in the input cable connects to the frame of the welder and to a ground in the fuse box. This insures proper grounding of the welder frame. If a separate disconnect switch is used, it should have two poles for the two hot lines and both should be fused as specified above.

The dual voltage 50/60 Hz. AC-225-GLM is shipped from the factory connected for the higher (230/220) nameplated voltage. For use on the lower (115/110) voltage, remove the welder top and side cover and reconnect and insulate the leads at the power switch according to the wiring diagram pasted inside the cover. Finally, replace the cover.

When connected to 115 volt 60 Hz. or 110 volt 50 Hz. input power, the rated welding output is 140 amps.

This rated current of 140 amps will reduce the capability of using larger electrodes and special techniques such as punching holes due to the lower output current. Only electrodes and techniques up to the 140 amps rating can be used with this reduced voltage input.

For supply lines, use three #10 or larger copper wires when using conduit. If supply line run requirements exceed 100', #8 or larger wire will be needed to prevent excessive voltage drops.

⚠ WARNING

Before attaching the electrode cable to the electrode holder or the work cable to clamp, be certain the welder is turned off or the input power is disconnected.

Attaching Electrode Cable to Holder

1. Loosen locking screw and slide handle off holder. Place handle over electrode cable.
2. Remove insulation from electrode cable $1" \pm 1/16"$ from end.
3. Back out cable connecting screw until end is flush with inside surface of jaw body.
4. Remove cable connecting clamp from holder jaws. Place clamp over bare end of electrode cable and insert into holder with clamp centered against connecting screw.

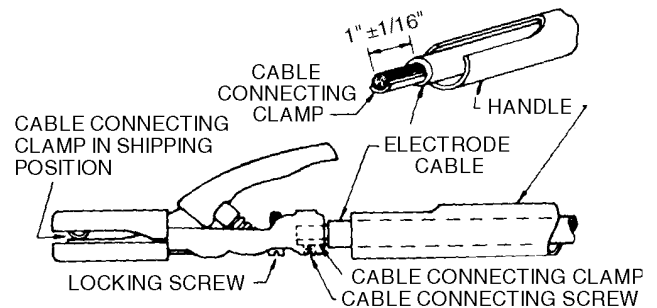

5. Tighten cable connecting screw securely against clamp.
6. Slide handle into position and secure with locking screw. When installing, turn the locking screw in until it is tight. The threaded end of the screw will then press against the inside of the handle and the head of the screw will be completely inside the handle.

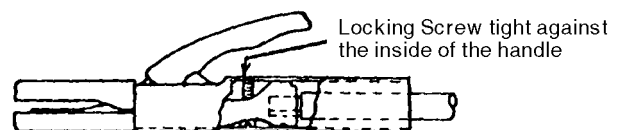

How To Use Parts List

1. Refer to the drawing below.
2. Find the part on the drawing.
3. Using the item number from the drawing find the part name and description in the table.
4. Get the welder code number found on the nameplate.
5. Order the part from The Lincoln Electric Company, or from a Lincoln Field Service Shop. Be sure to give the Parts List number, item number, part name and description, number required, the welder name, model number and code number.

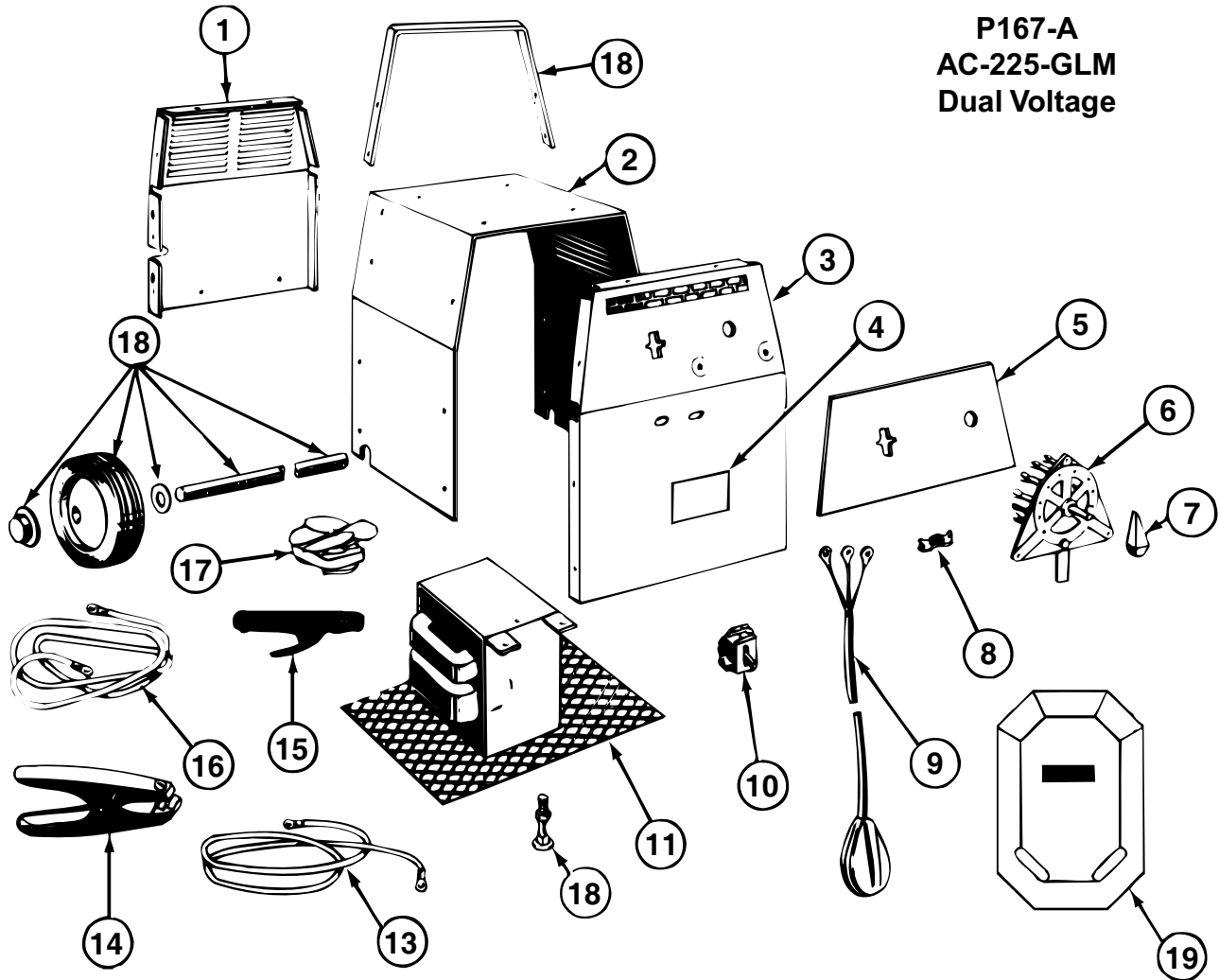

**P167-A
AC-225-GLM
Dual Voltage**

Item	Description	Item	Description
1	Back Case	10	Line Switch
2	Wrap Around	11	Transformer and Base
3	Front Case	13	Work Cable
4	Warning Decal	14	Work Clamp
5	Nameplate	15	Electrode Holder
6	Range Selector Switch	16	Electrode Cable
7	Handle	17	Fan Motor and Blade
8	Output Lead Clamp	18	Undercarriage Kit
9	Input Cable (230 V Input)	19	Hand Shield (Optional)

Attaching Work Cable to Clamp

Insert work cable through strain relief hole in work clamp and fasten securely with bolt and nut provided.

Electrode and Work Cable Replacement

Substitution of cables with larger sizes requiring connections to be made internally is not recommended. Connections for additional lengths or larger sizes should be properly made externally. Lincoln Electric QD (Quick Disconnect) connectors are available for this purpose.

If either cable requires replacement for other reasons, they should be replaced with the appropriate Lincoln parts—and only by qualified personnel.

Welding Current Selection

Each position on the current selector switch is marked with the output amperes for that setting. Turn the switch to the current required for each application.

There is a slight amount of play in each switch position. It is good practice to move the switch back and forth once within this play after switching to a new position. This wiping action keeps the contacts free from dirt and oxides.

CAUTION: Do not turn the selector switch while welding as this will damage the contacts.

MAINTENANCE

Routine preventative maintenance is not required. See your local Lincoln Electric Authorized Field Service Shop for necessary repairs.

LEARNING TO WELD

The serviceability of a product or structure utilizing this type of information is and must be the sole responsibility of the builder/user. Many variables beyond the control of The Lincoln Electric Company affect the results obtained in applying this type of information. These variables include, but are not limited to, welding procedure, plate chemistry and temperature, weldment design, fabrication methods and service requirements.

No one can learn to weld simply by reading about it. Skill comes only with practice. The following pages will help the inexperienced welder to understand welding and develop his skill. For more detailed information order a copy of “New Lessons in Arc Welding” listed on page 23.

Duty Cycle

The welder is rated 18% duty cycle at 60 Hz on all switch positions. This means that the arc can be drawn for 1.8 minutes out of each ten minute period without any danger of overheating. If the welder is used for more than 1.8 minutes during several successive ten minute periods, it may overheat and damage the windings. Be sure to leave the unit “on” during each 10 minute period to let the fan motor run for adequate cooling. Overheating reduces welder life.

WARNING—Pipe Thawing

The AC-225-GLM is not recommended for thawing or heating of frozen pipes.

Electrode Selection Guide

See Chart on Welder and page 21.

Arc Torch (Optional Accessory)

The arc torch (see page 17) is especially suited for use on these welders for brazing, welding non-ferrous metals and preheating before bending and forming.

The Arc-Welding Circuit

The operator’s knowledge of arc welding must go beyond the arc itself. He must know how to control the arc, and this requires a knowledge of the welding circuit and the equipment that provides the electric current used in the arc.

Figure 1 is a diagram of the welding circuit. The circuit begins where the electrode cable is attached to the welding machine and ends where the work cable is attached to the welding machine. Current flows through the electrode cable to the electrode holder, through the holder to the electrode and across the arc. On the work side of the arc, the current flows through base metal to the work cable and back to the welding machine. The circuit must be complete for the current to flow. To weld, the work clamp must be tightly connected to clean base metal. Remove paint, rust, etc. as necessary to get a good connection. Connect the work clamp as close as possible to the area you wish to weld. Avoid allowing the welding circuit to pass through hinges, bearings, electronic components or similar devices that can be damaged.

This arc-welding circuit has a voltage output of up to 79 volts which can shock.

⚠ **WARNING**



ELECTRIC SHOCK can kill.
Carefully review the ARC WELDING SAFETY PRECAUTIONS at the beginning of this manual.

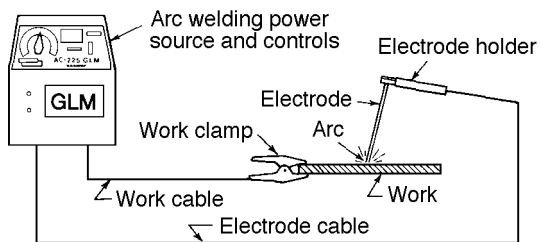

FIGURE 1—The welding circuit for shielded metal arc welding.

The electric arc is made between the work and the tip end of a small metal wire, the electrode, which is clamped in a holder and the holder is held by the welder. A gap is made in the welding circuit (see Figure 1) by holding the tip of the electrode 1/16-1/8" away from the work or base metal being welded. The electric arc is established in this gap and is held and moved along the joint to be welded, melting the metal as it is moved.

Arc welding is a manual skill requiring a steady hand, good physical condition, and good eyesight. The operator controls the welding arc and, therefore, the quality of the weld made .

What Happens in the Arc?

Figure 2 illustrates the action that takes place in the electric arc. It closely resembles what is actually seen during welding.

The “arc stream” is seen in the middle of the picture. This is the electric arc created by the electric current flowing through the space between the end of the electrode and the work. The temperature of this arc is about 6000°F, which is more than enough to melt metal. The arc is very bright, as well as hot, and cannot be looked at with the naked eye without risking painful injury. The very dark lens, specifically designed for arc welding, must be used with the hand or face shield whenever viewing the arc.

The arc melts the base metal and actually digs into it, much as the water through a nozzle on a garden hose digs into the earth. The molten metal forms a molten pool or crater and tends to flow away from the arc. As it moves away from the arc, it cools and solidifies. A slag forms on top of the weld to protect it during cooling.

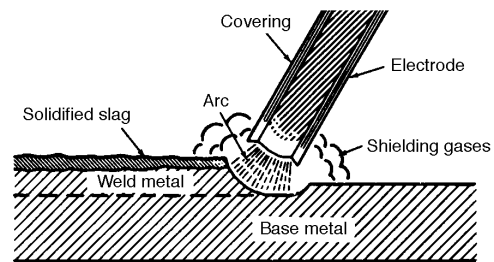

FIGURE 2—The welding arc.

The function of the covered electrode is much more than simply to carry current to the arc. The electrode is composed of a core of metal wire around which has been extruded and baked a chemical covering. The core wire melts in the arc and tiny droplets of molten metal shoot across the arc into the molten pool. The electrode provides additional filler metal for the joint to fill the groove or gap between the two pieces of the base metal. The covering also melts or burns in the arc. It has several functions. It makes the arc steadier, provides a shield of smoke-like gas around the arc to keep oxygen and nitrogen in the air away from the molten metal, and provides a flux for the molten pool. The flux picks up impurities and forms the protective slag. The principal differences between various types of electrodes are in their coatings. By varying the coating, it is possible to greatly alter the operating characteristics of electrodes. By understanding the differences in the various coatings, you will gain a better understanding of selecting the best electrode for the job you have at hand. In selecting an electrode you should consider:

1. The type of deposit you want, e.g. mild steel, stainless, low alloy, hardfacing.
2. The thickness of the plate you want to weld.
3. The position it must be welded in (downhand, out of position).
4. The surface condition of the metal to be welded.
5. Your ability to handle and obtain the desired electrode.

Four simple manipulations are of prime importance. **Without** complete mastery of these four, further welding is more or less futile. **With** complete mastery of the four, welding will be easy.

1. The Correct Welding Position

Beginners will find it easier to learn how to control the welding arc using the two-handed technique shown below. This requires the use of a headshield.

- Hold the electrode holder in your right hand.
- Touch your left hand to the underside of your right.
- Put the left elbow against your left side.
(For welding left-handed it is the opposite.)

If you are using a hand shield, hold the electrode holder in your right hand and the hand shield in your left. (For welding left-handed it is the opposite.)

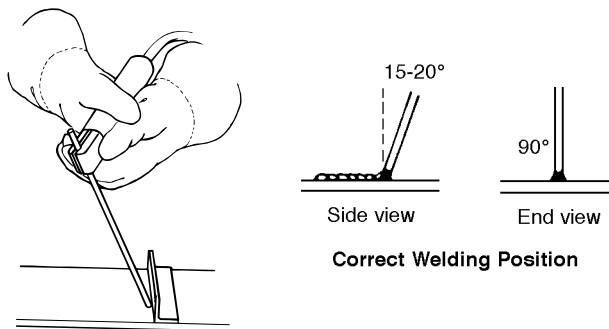

Whenever possible, weld from left to right (if right-handed). This enables you to see clearly what you are doing.

Hold the electrode at a slight angle as shown.

2. The Correct Way to Strike an Arc

Be sure the work clamp makes good electrical contact to the work.

Lower your headshield or hold the hand shield in front of your face. Scratch the electrode slowly over the metal and you will see sparks flying. While scratching, lift the electrode 1/8" and the arc is established.

NOTE: If you stop moving the electrode while scratching, the electrode will stick.

NOTE: Most beginners try to strike the arc by a fast jabbing motion down on the plate. Result: They either stick or their motion is so fast that they break the arc immediately.

3. The Correct Arc Length

The arc length is the distance from the tip of the electrode core wire to the base metal.

Once the arc has been established, maintaining the correct arc length becomes extremely important. The arc should be short, approximately 1/16 to 1/8" long. As the electrode burns off the electrode must be fed to the work to maintain correct arc length.

The easiest way to tell whether the arc has the correct length is by listening to its sound. A nice, short arc has a distinctive, "crackling" sound, very much like eggs frying in a pan. The incorrect, long arc has a hollow, blowing or hissing sound.

4. The Correct Welding Speed

The important thing to watch while welding is the puddle of molten metal right behind the arc. **Do NOT watch the arc itself.** It is the appearance of the puddle and the ridge where the molten puddle solidifies that indicate correct welding speed. The ridge should be approximately 3/8" behind the electrode.

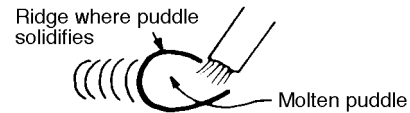

Most beginners tend to weld too fast, resulting in a thin, uneven, "wormy" looking bead. They are not watching the molten metal.

IMPORTANT: For general welding it is not necessary to weave the arc; neither forwards and backwards nor side-ways. Weld along at a steady pace. You will find it easier.

NOTE: When welding on thin plate, you will find that you will have to increase the welding speed, whereas when welding on heavy plate, it is necessary to go more slowly in order to get good penetration.

Practice

The best way of getting practice in the four skills that enable you to maintain:

- Correct Welding Position
- Correct Way To Strike An Arc
- Correct Arc Length
- Correct Welding Speed

is to spend a little more time on the following exercise.

Use the following:

Mild Steel Plate3/16" or heavier
 Electrode1/8" Fleetweld 180
 Current Setting.....105 Amps AC

Do the following:

1. Learn to strike the arc by scratching the electrode over the plate. Be sure the angle of the electrode is correct. If you have a headshield use both hands.
2. When you can strike an arc without sticking, practice the correct arc length. Learn to distinguish it by its sound.
3. When you are sure that you can hold a short, crackling arc, start moving. Look at the molten puddle constantly, and look for the ridge where the metal solidifies.
4. Run beads on a flat plate. Run them parallel to the top edge (the edge farthest away from you). This gives you practice in running straight welds, and also, it gives you an easy way to check your progress. The 10th weld will look considerably better than the first weld. By constantly checking on your mistakes and your progress, welding will soon be a matter of routine.

Common Metals

Most metals found around the farm or small shop are low carbon steel, sometimes referred to as mild steel. Typical items made with this type of steel include most sheet metal, plate, pipe and rolled shapes such as channels, angle irons and "I" beams. This type of steel can usually be easily welded without special precautions. Some steel, however, contains higher carbon. Typical applications include wear plates, axles, connecting rods, shafts, plowshares and scraper blades. These higher carbon steels can be welded successfully in most cases; however, care must be taken to follow proper procedures, including preheating the metal to be welded and, in some cases, carefully controlling the temperature during and after the welding process. For further information on identifying various types of steels and other metals, and for proper procedures for welding them, we again suggest you purchase a copy of "New Lessons in Arc Welding" (see page 23).

Regardless of the type of metal being welded, it is important in order to get a quality weld that it be free of oil, paint, rust or other contaminants.

Types of Welds

Five types of welding joints are: Butt Welds, Fillet Welds, Lap Welds, Edge Welds and Corner Welds.

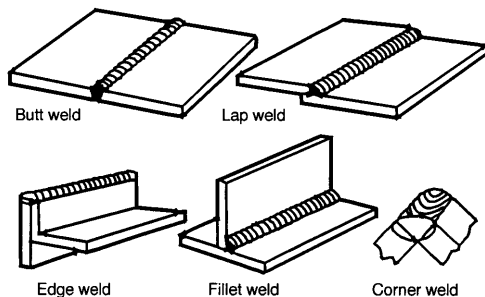

Of these, the Butt Weld and Fillet Weld are the two most common welds.

Butt Weld

Butt Welds are the most widely used welds. Place two plates side by side, leaving 1/16" (for thin metal) to 1/8" (for heavy metal) space between them in order to get deep penetration.

Tack the plates at both ends, otherwise the heat will cause the plates to move apart. (See drawing):

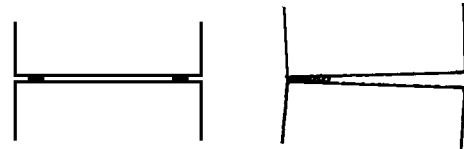

Now weld the two plates together. Weld from left to right (if right-handed). Point the electrode down in the crack between the two plates, keeping the electrode slightly tilted in the direction of travel.

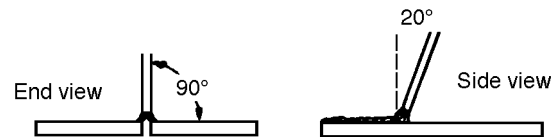

Watch the molten metal to be sure it distributes itself evenly on both edges and in between the plates.

Penetration

Unless a weld penetrates close to 100%, a butt weld will be weaker than the material welded together.

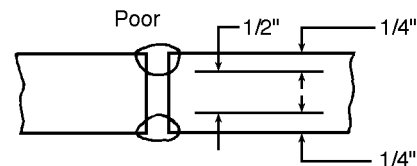

In this example, the total weld is only 1/2 the thickness of the material; thus the weld is only approximately half as strong as the metal.

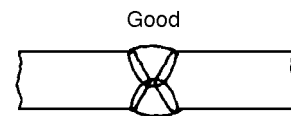

In this example, the joint has been flame beveled or ground prior to welding so that 100% penetration could be achieved. The weld, if properly made, is as strong or stronger than the original metal.

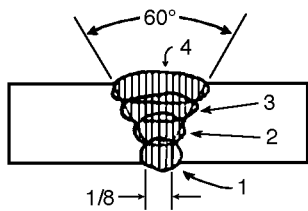

Fillet Welds

When welding fillet welds, it is very important to hold the electrode at a 45° angle between the two sides, or the metal will not distribute itself evenly.

To make it easy to get the 45° angle, it is best to put the electrode in the holder at a 45° angle, as shown:

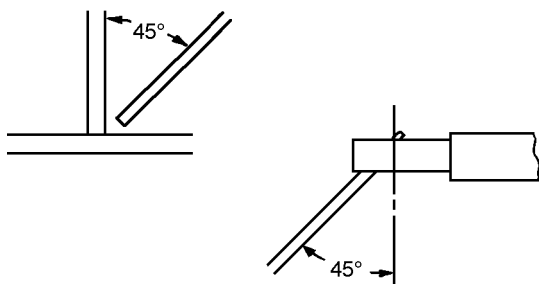

Multiple Pass Welds

Make multiple pass horizontal fillets as shown in the sketch. Put the first bead in the corner with fairly high current. Hold the electrode angle needed to deposit the filler beads as shown putting the final bead against the vertical plate.

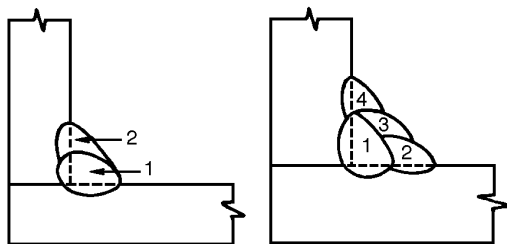

Welding in the Vertical Position

Welding in the vertical position can be done either vertical-up or vertical-down. Vertical-up is used whenever a large, strong weld is desired. Vertical-down is used primarily on sheet metal for fast, low penetrating welds.

Vertical-Up Welding

The problem, when welding vertical-up, is to put the molten metal where it is wanted and make it stay there. If too much molten metal is deposited, gravity will pull it

downwards and make it “drip.” Therefore a certain technique has to be followed:

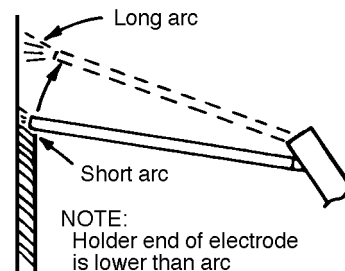

1. Use 1/8" (90-105 amps) or 3/32" (60 amps) Fleetweld 180 electrode.
2. When welding, the electrode should be kept horizontal or pointing slightly upwards. (See drawing.)
3. The arc is struck and metal deposited at the bottom of the two pieces to be welded together.
4. Before too much molten metal is deposited, the arc is SLOWLY moved 1/2-3/4" upwards. This takes the heat away from the molten puddle, which solidifies. (If the arc is not taken away soon enough, too much metal will be deposited, and it will “drip.”)
5. The upward motion of the arc is caused by a very slight wrist motion. Most definitely, the arm must not move in and out, as this makes the entire process very complicated and difficult to learn.
6. If the upward motion of the arc is done correctly with a wrist motion, the arc will automatically become a long arc that deposits little or no metal. (See drawing.)
7. During this entire process the ONLY thing to watch is the molten metal. As soon as it has solidified, the arc is SLOWLY brought back, and another few drops of metal are deposited. DO NOT FOLLOW THE UP AND DOWN MOVEMENT OF THE ARC WITH THE EYES. KEEP THEM ON THE MOLTEN METAL.
8. When the arc is brought back to the now solidified puddle, IT MUST BE SHORT, otherwise no metal will be deposited, the puddle will melt again, and it will “drip.”
9. It is important to realize that the entire process consists of SLOW, DELIBERATE movements. There are no fast motions.

Vertical-Down Welding

Vertical-down welds are applied at a fast pace. These welds are therefore shallow and narrow, and as such are excellent for sheet metal. Do not use the vertical-down technique on heavy metal. The welds will not be strong enough.

1. Use 1/8 or 3/32" Fleetweld 180 electrode.
2. On thin metal, use 60-75 amps. (14 ga 75 amps — 16 ga 60 amps.)
3. Hold the electrode in a 30-45° angle with the tip of the electrode pointing upwards.
4. Hold a VERY SHORT arc, but do not let the electrode touch the metal.
5. An up and down whipping motion will help prevent burn-through on very thin plate.
6. Watch the molten metal carefully.

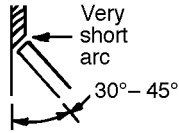

The important thing is to continue lowering the entire arm as the weld is made so the angle of the electrode does not change. Move the electrode so fast that the slag does not catch up with the arc. Vertical-down welding gives thin, shallow welds. It should not be used on heavy material where large welds are required.

Overhead Welding

Various techniques are used for overhead welding. However, in the interest of simplicity for the inexperienced welder the following technique will probably take care of most of his needs for overhead welding:

1. Use 1/8" (90-105 amps) or 3/32" (60 amps) Fleetweld 180 electrode.
2. Put the electrode in the holder so it sticks straight out.
3. Hold the electrode at an angle approximately 30° off vertical, both seen from the side and seen from the end.

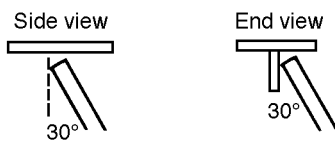

The most important thing is to hold a VERY SHORT arc. (A long arc will result in falling molten metal; a short arc will make the metal stay.)

If necessary — and that is dictated by the looks of the molten puddle — a slight back and forth motion along the seam with the electrode will help prevent “dripping.”

Welding Sheet Metal

Welding sheet metal presents an additional problem. The thinness of the metal makes it very easy to burn through. Follow these few simple rules:

1. Hold a very short arc. (This prevents burn through, since beginners seem to hold too long an arc.)

2. Use 1/8 or 3/32" Fleetweld 180 electrode.
3. Use low amperage. 75 amps for 1/8" electrode, 40-60 amps for 3/32" electrode.
4. Move fast. Don't keep the heat on any given point too long. Keep going. Whip electrode.
5. Use lap welds whenever possible. This doubles the thickness of the metal.

Hardfacing

There are several kinds of wear. The two most often encountered are:

1. *Metal to Ground Wear.*
(Plowshares, bulldozer blades, buckets, cultivator shares, and other metal parts moving in the soil.)
2. *Metal to Metal Wear.*
(Trunnions, shafts, rollers and idlers, crane and mine car wheels, etc.)

Each of these types of wear demands a different kind of hardsurfacing electrode.

When applying the proper electrode, the service life of the part will in most cases be more than double. For instance, hardsurfacing of plowshares results in 3-5 times more acreage plowed.

How to Hardface the Sharp Edge (Metal to Ground Wear)

1. Grind the share, approximately one inch wide along the edge, so the metal is bright.
2. Place the share on an incline of approximately 20-30°. The easiest way to do this is to put one end of the share on a brick. (See drawing.)

Most users will want to hardface the underside of the share, but some might find that the wear is on the top side. The important thing is to hardface the side that wears.

3. Use 1/8" Abrasoweld™ electrode at 90-105 amps. Strike the arc about one inch from the sharp edge.
4. The bead should be put on with a weaving motion, and it should be 1/2 to 3/4" wide. Do not let the arc blow over the edge, as that will dull the edge. (See drawing.)

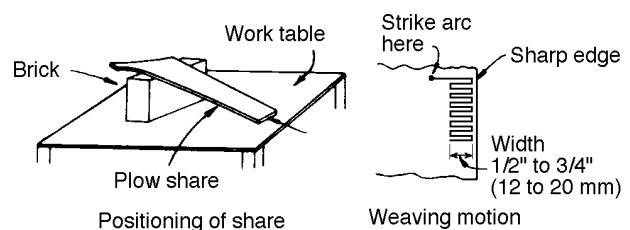

- Use the back-stepping method. Begin to weld 3" from the heel of the share and weld to the heel. The second weld will begin 6" from the heel, the third weld 9" from the heel, etc.

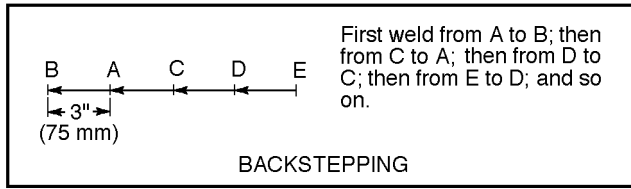

Backstepping greatly reduces the chances for cracking of the share, and it also greatly reduces possible warpage.

NOTE: The entire process is rather fast. Many beginners go much to slow when hardfacing plow shares, running the risk of burning through the thin metal.

Hardfacing of Idler and Roller (Metal to Metal Wear)

A very common application of hardfacing for metal to metal wear is the hardfacing of idlers and rollers and the rails that ride on these rollers and idlers.

The reason for hardfacing these parts is primarily monetary. A few dollars worth of electrode will completely build up a roller or idler, and the hard surface will outlast several times the normal life of such rollers and idlers.

If the following procedure is followed, it is not even necessary to remove the grease bearing while welding. This will save a lot of time:

- The roller (or idler) is inserted on a piece of pipe that is resting on two sawbucks. This enables the operator to turn it while welding.
- Use Jet-LH® BU-90 electrodes, 5/32" at 175 amps or 3/16" at 200 amps.
- Weld across the wearing surface. Do not weld around.
- Keep the roller (or idler) cool by quenching with water, and by stopping the welding periodically. This will prevent shrinking of the roller (or idler) on the grease bearing.
- Build-up to dimension. The weld metal deposited by BU-90 electrode is often so smooth that machining or grinding is not necessary.

NOTE: The quenching of the roller (or idler) has another purpose: It increases the hardness — and thus the service life — of the deposit.

The hardfacing of the rails is a lot easier:

- Place the rails with the side that rides on the rollers and idlers upwards.
- Use Jet-LH BU-90 electrodes. Same ampere setting as on the idlers and rollers.

- Build-up to size.

- Do not quench.** This will make the deposit slightly softer than the deposit on the idlers and rollers. That means that the wear will primarily be on the rails, which are a lot easier and less time-consuming and cheaper to build-up.

NOTE: The same electrode — BU-90 — will give the operator two desired hardnesses, just by a difference in cooling rate, making it possible to put the hardest deposit on the most expensive parts.

NOTE: The outside of the rails (the side that comes in contact with the ground) should be surfaced with Abrasoweld, since this side has Metal to Ground wear.

Welding Cast Iron

When welding on a piece of cold cast iron, the tremendous heat from the arc will be absorbed and distributed rapidly into the cold mass. This heating and sudden cooling creates WHITE, BRITTLE cast iron in the fusion zone.

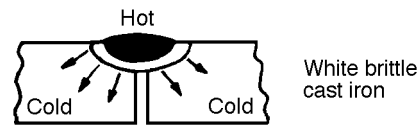

This is the reason why welds in cast iron break. Actually, one piece of the broken cast iron has the entire weld on it, and the other piece has no weld on it.

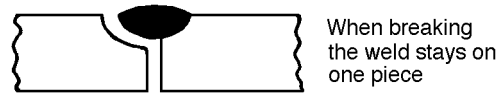

In order to overcome this, the welding operator has two choices:

- He can preheat the entire casting to 500-1200°F. If the cast iron is hot before welding, there will be no sudden chilling which creates brittle white cast iron. The entire casting will cool slowly.
- He can weld 1/2" at a time, and not weld at that spot again until the weld is completely cool to the touch.

In this way no large amount of heat is put into the mass.

Most inexperienced welders will probably use the second method, because they have no way of preheating large castings. Smaller castings can easily (and should) be preheated before welding. A forge, stove, a fire, or the Arc Torch are all excellent means of preheating.

When using the 1/2" at a time method, it is recommended to start 1/2" away from the previous bead and weld into the previous bead (backstepping).

After welding Cast Iron, protect the casting against fast cooling. Put it in a sand (or lime) box.

If sand or lime is not available, cover it with sheet metal or any other non-flammable material that will exclude drafts and retain heat.

Cast Iron Plate Preparation

Wherever practical, the joint to be welded should be “veed” out by grinding or filing to give complete penetration. This is especially important on thick castings where maximum strength is required. In some instances a back-up strip may be used and plates may be gapped 1/8" or more.

On sections where only a sealed joint is required and strength is not important, the joint may be welded after slightly veeing out the seam as shown.

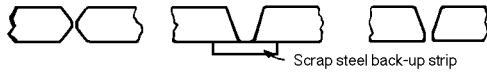

Three ways to prepare plates where complete penetration is necessary.

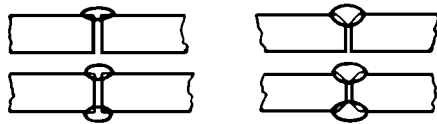

Single and double beads, with and without beveling for tight, partial strength joints.

Cutting Do not exceed the Duty Cycle — See page 9)

The arc welder and the electrode can be used for cutting steel and cast iron. Follow this procedure:

1. Use 1/8 or 5/32" Fleetweld 180 electrode.
2. Set welder on maximum (225 amps).
3. Hold long arc on edge of metal, melting it.
4. Push the arc through the molten metal, forcing it to fall away.
5. Raise the electrode, and start over again.

The important thing is to continue this up-and-down, sawing motion, melting the metal and pushing it away.

If a lot of cutting is to be done, soak each electrode in water for a minute or two. It keeps them cooler, and the electrodes last longer.

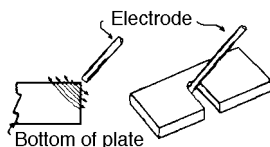

WARNING



ELECTRIC SHOCK can kill.

When soaking electrode keep your gloves and clothing dry. Never dip an electrode holder in water.

Piercing Holes

1. Welder setting: Maximum (225 amps).
2. Electrode: 1/8 or 5/32" Fleetweld 180.
3. Hold the electrode with a long arc perpendicular over the spot where the hole is to be made.
4. When the metal is molten, push the electrode through the molten puddle.
5. Give the molten metal a chance to fall through the hole.
6. Circle with a long arc around the edge of the hole until the desired diameter hole has been made.

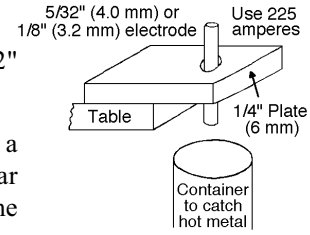

Making holes with an electrode.

If the electrode is pushed through too soon it will stick in the puddle. Be sure the metal is molten before pushing through.

NOTE: On heavy metal (5/16" or thicker), position the plate to be pierced vertically, and the electrode horizontally. This allows the molten metal to drip away freely as you are boring through.

USING THE CARBON ARC TORCH

- ... Welding Aluminum and Copper Alloys
- ... Brazing and Soldering
- ... Heating, Bending and Straightening

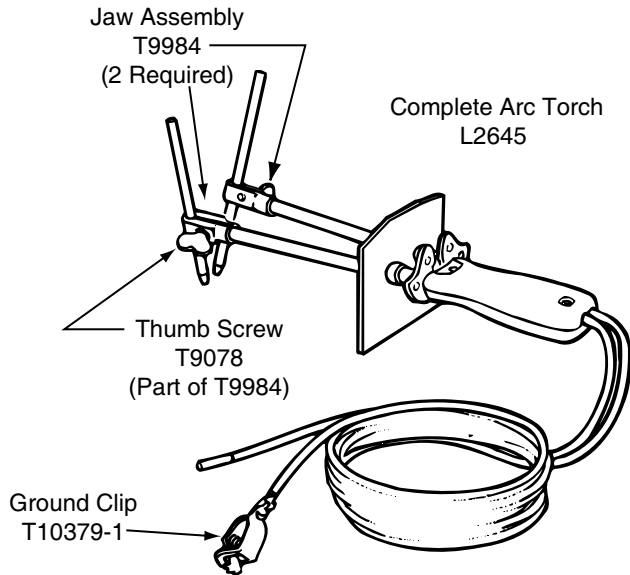

Required Equipment

1. A Lincoln Carbon Arc Torch L-2645; Its rating is 100 amperes.
2. 1/4, 5/16 or 3/8" carbons: Use only copper coated and cored carbons to avoid overheating the holder and provide even burning of the carbons.
3. Any AC or DC welder: Carbons burn much faster on DC than they do on AC. Also the carbon connected to the positive DC output should be larger than the carbon connected to the negative DC output so both carbons burnoff at about the same rate.

Torch Connections

Insert the straight ferrule on the end of one arc torch lead into the standard electrode holder. Attach the spring clip on the end of the other lead to either the work clamp or the welding table where the work lead is clamped. If connected to the table, insulate the work from the table. See drawing below.

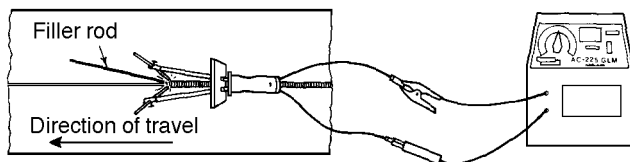

⚠ WARNING



ELECTRIC SHOCK can kill.

The carbon arc torch rays will cause severe arc burns to exposed skin. Therefore, a pair of work gloves, long sleeved shirt or sleevelets, and an apron are recommended.

Use an arc welding headshield or hand shield with a No. 11 or No. 12 lens. Oxyacetylene goggles are not sufficient eye and face protection.

When adjusting the length of carbons, be sure the welder is turned off. An arc flash while making this adjustment can burn hands or eyes.

When laying the torch down, avoid touching the carbons to the grounded bench or work. This is best done by turning the welder off. As an alternative, either set the torch on an insulated surface or lay it on its side with the leads hanging down over the bench so the handle rests on the bench top.

DO NOT EXCEED THE OUTPUT DUTY CYCLE OF THE WELDER. Exceeding this duty cycle in successive 10 minute periods can overheat the welder and damage the windings. (See page 9.)

Heat Settings

Recommended current settings for different material thicknesses and carbon sizes are given in the table. Generally, use only enough current to cause the filler metal to flow freely on the work. Do not use currents so high that the copper coating burns away more than 1/2" above the arc.

Set the carbons to extend about 2" beyond the copper jaws.

⚠ WARNING

Be sure the welder is turned off when making this adjustment.

Thickness of Base Metal	Approximate Current Setting (AC)	Carbon Diameter
1/32"	30-50 amps	1/4"
1/16"	50-60 amps	1/4"
1/8"	70-80 amps	5/16"
1/4"	90-100 amps	3/8"

After adjusting the welder current and setting the carbon stickout, start the welder and you are ready to go.

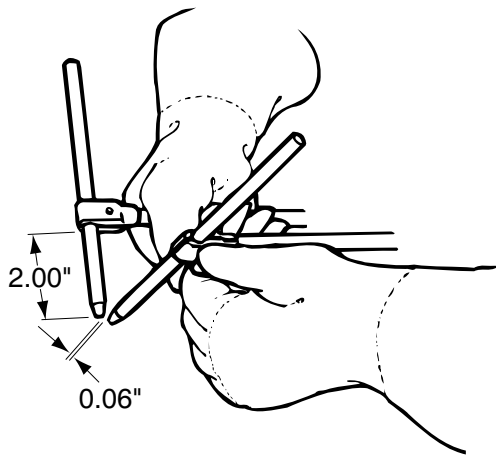

Use the thumb control on the arc torch to rotate the carbons until they touch. Start the arc by reversing the thumb control setting to spread the carbons 1/16 to 3/16" apart. As the carbons burn away use the thumb control to maintain the desired arc. When the proper arc can no longer be maintained, turn the welder off and readjust the carbon stickout.

A wide, soft, quiet flame gives the best results for most jobs. When the carbon tips are too close together a small flame accompanied by a hissing or crackling sound results.

The shape of a good flame is illustrated below. The flame fans out to form a "fish tail" shape with inner and outer cone. To heat a crack or a corner, position the flame as illustrated.

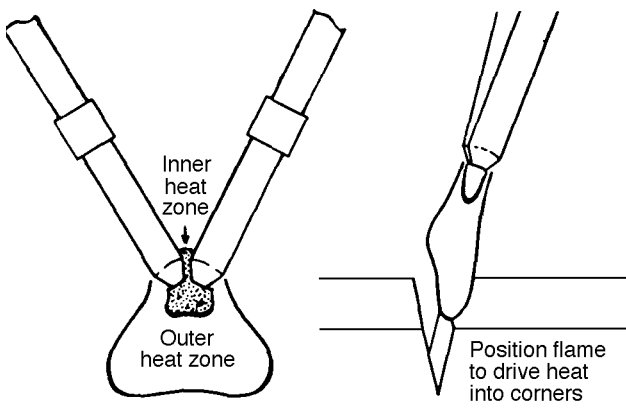

Heat intensity is controlled by changing the current setting, by moving the carbons closer together or farther apart, or by changing the distance between the flame and work. When the work sets on a metal table, the table absorbs some of the heat. To avoid high heat loss, the part can be set of thin metal strips or some insulation.

Removal of Nuts and Bolts: Apply heat with the arc torch for a few seconds and nuts can be easily turned off.

Heating Heavy Parts

Heavy metal can be heated more rapidly by connecting the work lead to the work so the arc is between the carbons and the work as well as between the two carbons. To do this, connect the lead carbon (the carbon which leads the direction of travel) to the electrode holder. Connect both the trail carbon and the work cable to the work or to the welding table. With this connection, raising the torch reduces the amount of the arc going to the work thus reducing the heating. The arc between the carbons and work tends to pit the surface of the work.

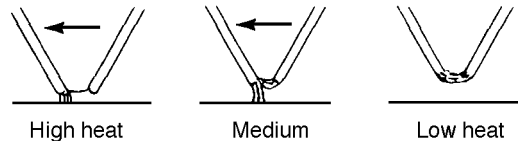

Welding Aluminum Alloys With The Arc Torch

The need to repair aluminum parts continues to grow. These repairs can be simply made with an AC welder using Aluminweld DC coated electrodes as a filler rod and The Carbon Arc Torch. The arc torch preheats the aluminum plate, assuring good fusion.

Work Preparation

Here are recommended edge preparations and types of joints for different thicknesses of base metal. All welds must be made in the downhand position. Round parts must be rotated.

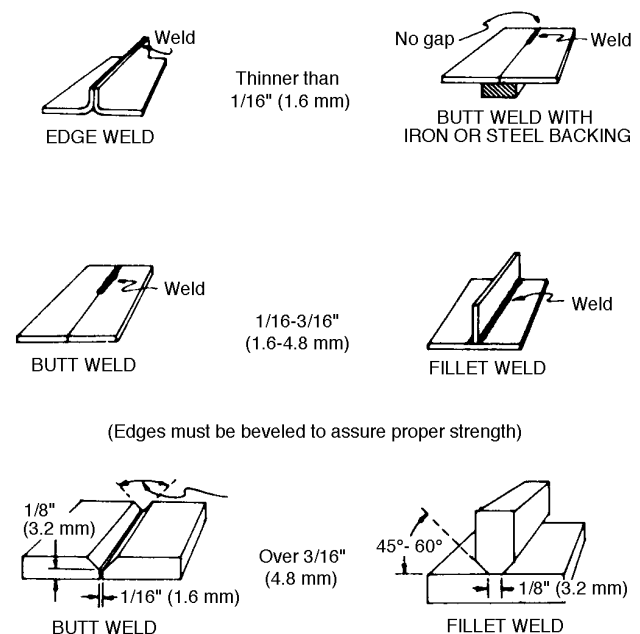

Joints

Welding Procedures

1. Use the recommended AC currents and carbon sizes listed in the Table on page 17. A headshield is required.
2. Use a 1/8" 'Aluminweld' coated electrode as a filler rod. Hold it in the left hand (for right-handed people).
3. Hold the arc torch in your right hand and start the arc by shorting the carbons together and adjusting them to a 1/16" gap.
4. Hold the arc torch as shown here. Hold your eyes right over the arc torch looking in between the two carbons.
5. Play the arc 3" to 4" up and down the joint at the start. This preheat helps to give a smoother bead and an easier start when the filler rod is applied.
6. Move the torch to the beginning of the joint (right-handed people should begin at the right and move left).
7. Place the tip of the electrode in the arc. If the coating melts off and flows easily into the joint, the metal is hot enough to start welding.
8. Let a droplet of the filler rod melt and fuse into the joints.
9. Watch the molten puddle. Add more filler metal by moving the end of the rod in and out of the arc as the right hand moves the arc torch slowly along the joint.

Practice

When you first try to weld with these procedures, you may have a tendency to burn through. Therefore, a few minutes practice before working on the parts to be welded is recommended. Use scrap material about as thick as the part you are going to weld. Practice the technique to get the feel of the arc.

Brazing

The techniques for brazing with an arc torch are very much like the ones used for gas brazing. Only enough heat is needed to melt the filler metal and to raise the parts to be brazed to the melting temperature of the filler metal — usually slightly over 1,000°F. A good brazed joint is assured when the filler metal flows into the joint and adheres evenly to the surfaces. Use only enough filler metal to make a smooth joint. Use standard gas brazing rod and flux .

Heat the end of the brazing rod and dip it into the flux. The flux will stick to the hot rod. Play the arc back and forth a short distance along the seam when the right temperature is reached. Apply flux as needed and melt off brazing rod to fill the seam. Move along the seam until the job is complete.

If the part being brazed does not get hot enough, increase the current or hold the torch closer to the work. Whenever possible, have the joint horizontal to secure best flow of molten filler rod.

Soldering

The arc torch can be used to solder copper piping and other copper, tinned and galvanized parts. Best results are obtained with overlapping pieces. Clean the surfaces to be soldered and cover them with soldering flux to prevent oxidation and to speed soldering. Acid core solder produces good results.

The best soldering can be done on the lowest current tap of the welder. Use approximately 1/4" diameter carbon and make certain to bring it into firm contact with the piece to be soldered to avoid arcing. Simply play the arc on the area to be soldered and feed solder into the joint as it reaches proper temperature. After the soldering is completed, the carbon must be removed quickly to prevent arcing. Never use so much heat that the solder boils.

Heating, Bending and Straightening

Choose the carbon size and current setting depending upon the thickness of the metal to be heated. Play the arc over the section to be heated until the desired temperature is reached. For bending this is usually a dull red color on ordinary mild steels.

Do not hold the carbons too close to the work. Arcing the surface increases the tendency for the base metal to crack when the bending is done.

Carbon Arc Torch Maintenance

The handle is held together with a screw and spring lock washer to give just the right friction on the electrode shafts. If the handle is removed for any reason, the screw at the front of the handle should be turned up snugly and then backed of 1/2 turn to give the proper friction.

Occasionally the screws in the copper jaws will bind, so it will be advantageous to lubricate the threads with graphite grease and work the grease well into the threaded jaw.

SELECTING ELECTRODES

Which electrode is best for the particular job . . . how do you use it? These are important questions because the cost, quality, and appearance of your work depends on proper electrode selection and application. MILD STEEL ELECTRODES may be classified into the following groups:

Out-of-Position Group (E6011)

This group includes electrodes which have a snappy, deep penetrating arc and fast freezing deposits.

These electrodes are used for general purpose all-position fabrication and repair welding; also the best choice for pipe welding and sheet metal butt, corner and edge welds. They can be used for repair work when dirt, grease, plating or paint cannot be completely cleaned from the steel. Typically used with motions “A” and “B” (below) for the first pass on vertical-up welds.

High-Deposit Group (E6027, E7024)

This group includes the heavy coated, iron powder electrodes with their soft arc and fast deposit rates. These electrodes have a heavy slag and produce exceptionally smooth beads. They are generally used for production welding where all work can be positioned for downhand welding. Stringer beads, with drag technique, are always preferred over weave passes with these electrodes.

High-Speed Group (E6012, E6013, E7014)

This group includes electrodes which have a moderately forceful arc and deposit rates between those of the out-off position and high-deposit electrodes. They are primarily general purpose production electrodes especially for downhill fillets and laps or short and irregular welds that change direction or position. Also widely used in maintenance and recommended for sheet metal fillet and lap welds. Motion “D” (below) is generally used for vertical-up welding, but motions “A” and “B” are also suitable.

Low Hydrogen Group (E7018, E7028)

These electrodes are generally called “low hydrogen.” The name comes from the fact that their coating contains little hydrogen in either moisture or chemical form. Low hydrogen electrodes offer these benefits: outstanding crack resistance, lowest porosity on sulphur bearing steels, and capable of X-ray quality deposits. Thus, they are the first choice when welding “problem” steels. E7018 can be used in all positions, with Motion “C” recommended for the first pass on vertical-up welds. NEVER use a whipping technique or a long arc with these electrodes. ALWAYS fill craters by drawing electrodes away slowly. ALWAYS keep these electrodes dry. Electrodes not used within a few hours after a container is opened must be stored in heat cabinets. LH-73 is recommended with the AC-225-GLM. Normally, DC(+) is preferred for these electrodes.

Motions

Manipulation depends on the joint. Some of the common motions are shown above.

Motion “A” is a straight whipping motion used with fast-freeze electrodes to make stringer beads in all positions and

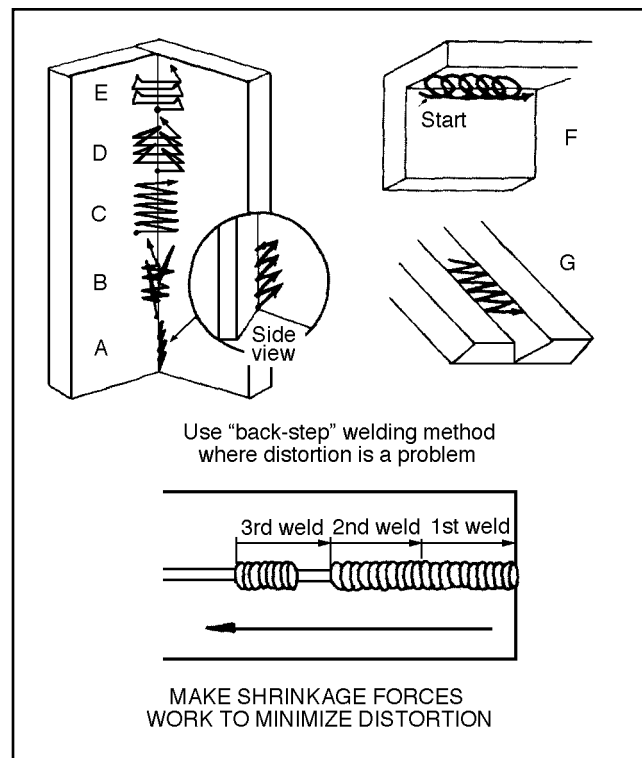

on all types of joints. It keeps the molten pool small and lets it freeze quickly so the weld metal doesn’t spill down or through the joint. Keep arc short when in the crater and longer during whip out from the crater.

Motion “B” is a whipping motion combined with a slight weave in the crater. It is used with fast-freeze electrodes as the first pass on vertical fillets and V-butts.

Motion “C” is a simple side-to-side weave used with all types of electrodes to make fill passes on vertical fillets and V-butts. Also sometimes used with fill-freeze and low hydrogen electrodes to make the first pass on these joints.

Motion “D” is a triangular weave used with fill-freeze and low hydrogen electrodes to make one pass vertical fillets and V-butts. It results in a larger weld than Motion “C”.

Motion “E” is a box weave used with all types of electrodes to make fill passes on vertical fillets and V-butts. It is similar to Motion “C,” but with a distinct pause and slight upward motion at each edge of the weld to assure complete crater filling and elimination of undercut.

Motion “F” is a circular motion used with all types of electrodes to make overhead welds. Sometimes accompanied by a slight whip after each oscillation in the crater. Always use a series of stringer beads overhead; do not weave.

Motion “G” is a simple side-to-side weave used with all electrodes on wide fillets or butts in the flat position.

NOTE: The AC-225-GLM is an AC welder. DC electrodes have been included in the chart below for added information.

ELECTRODE IDENTIFICATION AND OPERATION DATA

Coating Color	Conforms to Test Requirements of AWS Class	Electrode Brand Name	Electrode Polarity (+) = "Reverse" (-) = "Straight"	Sizes and Current Ranges (Amps.)							
				5/64" Size	3/32" Size	1/8" Size	5/32" Size	3/16" Size	7/32" Size	1/4" Size	5/16" Size
MILD STEEL											
Brick Red	E6010	Fleetweld 5P	DC(+)		40-75	75-130	90-175	140-225	200-275	220-325	240-400
Tan	E6012	Fleetweld 7	DC(-) AC			80-135 90-150	110-180 120-200	155-250 170-275	225-295 250-325	245-325 275-360	
Gray	E6011	Fleetweld 35	AC DC(+)		50-85 40-75	75-120 70-110	90-160 80-145	120-200 110-180	150-260 135-235	190-300 170-270	
Red Brown	E6011	Fleetweld 35LS	AC DC(±)			80-130 70-120	120-160 110-150				
Gray Tan	E6013	Fleetweld 37	AC DC(±)	50-80 45-75	75-105 70-95	110-150 100-135	160-200 145-180	205-260 190-235			
Gray Brown	E7014	Fleetweld 47	AC DC(-)			110-160 100-145	150-225 135-200	200-280 185-235	260-340 235-305	280-425 260-380	
Gray*	E6013	Fleetweld 57	AC DC(-)			100-150 90-135	150-200 135-180	200-260 180-235			
Brown	E6011	Fleetweld 180	AC DC(±)		40-90 40-80	60-120 55-110	115-150 105-135				
Gray	E7024	Jetweld® 1	AC DC(±)		65-120 60-110	115-175 100-160	180-240 160-215	240-300 220-280	300-380 270-340	340-440 320-400	
Red Brown	E6027	Jetweld 2	AC DC(±)				190-240 175-215	250-300 230-270	300-380 270-340	350-450 315-405	
Gray*	E7024	Jetweld 3 ⁽¹⁾	AC DC(±)		65-120 60-110	115-175 100-160	180-240 160-215	240-315 215-285	300-380 270-340	350-450 315-405	380-600 360-600
Gray	E7018	Jetweld LH-70	DC(+) AC		70-100 80-120	90-150 110-170	120-190 135-225	170-280 200-300	210-330 260-380	290-430 325-440	375-500 400-530
Gray*	E7018 (white numbers)	Jetweld LH-73	AC DC(+)		70-90 65-85	95-135 90-125	140-200 130-185				
White	E7018	Jetweld LH-75	DC(+) AC		70-110 80-110	95-160 100-170	120-190 135-225	180-270 210-290	250-330 270-370	300-400 325-420	
Gray	7018 (white numbers)	JET-LH 78	DC(+) AC		85-110	110-160 120-170	130-200 140-230	180-270 210-290	250-330 270-370	300-400 325-420	
Gray Brown	E7028	Jetweld LH-3800	AC DC(+)				180-270 170-240	240-330 210-300	275-410 260-380	360-520	
⁽¹⁾ 5/16" Jetweld 3 does not conform to any AWS/ASME classification.											
LOW ALLOY, HIGH TENSILE STEEL											
Pink	E7010-A1	Shield Arc® 85	DC(+)		50-90	75-130	90-175	140-225			
Pink*	E7010-A1	Shield-Arc 85P	DC(+)					140-225			
Tan	E7010-G	Shield Arc HYP	DC(+)			75-130	90-185	140-225	160-250		
Gray	E8010-G	Shield-Arc 70+	DC(+)			75-130	90-185	140-225			
Gray Brown	E8018-C1	Jet-LH® 8018 C1	DC(+) AC			90-150 110-160	120-180 140-200	180-270 200-300		250-350 300-400	
Gray Brown	E8018-C3	Jet-LH 8018 C3	DC(+) AC			110-150 120-170	130-190 140-225	180-270 210-290	250-330 270-370	300-400 325-420	
Gray	E8018-B2	Jetweld LH-90	DC(+) AC			110-150 120-170	130-190 140-225	180-270 210-290			
Gray	E11018-M	Jetweld LH-110M	DC(+) AC		70-100 80-110	85-155 100-170	120-195 135-225	160-280 200-310	190-310 240-350	230-360 290-410	
STAINLESS STEEL											
Pale Green	E308-15	Stainweld® 308-15	DC(+)		30-70	50-100	75-130	95-165		150-225	
Gray	E308-16	Stainweld 308-16	DC(+); AC	20-45	30-60	55-95	80-135	115-185		200-275	
Gray	E308L-16	Stainweld 308L-16	DC(+); AC		30-65	55-100	80-140	115-190			
Gray	E309-16	Stainweld 309-16	DC(+); AC		30-60	55-95	80-135	115-185		200-275	
Gray	E310-16	Stainweld 310-16	DC(+); AC		30-65	55-100	80-140	120-185		200-275	
Gray	E316L-16	Stainweld 316L-16	DC(+); AC		30-65	55-100	80-140	115-190			
Pale Green	E347-15	Stainweld 347-15	DC(+)		30-70	50-100	75-130	95-165			
Gray	E347-16	Stainweld 347-16	DC(+); AC		30-60	55-95	80-135	115-185			
ALUMINUM											
White		Aluminweld®	DC(+)		20-55	45-125	60-170	85-235			
					1/8" Size	5/32" Size	3/16" Size	1/4" Size			
CAST IRON											
Light Tan	Est	Ferroweld®	DC(+); AC		80-100						
Black	ENICl	Softweld®	DC(±) AC		60-110 65-120	100-135 110-150					
HARDFACING											
Black		Abrasoweld	DC(±) AC		40-150 50-165	75-200 80-220	110-250 120-275	150-375 165-410			
Black		Faceweld® 1	DC(+); AC				60-150				
Black		Faceweld 12	DC(+); AC				60-150				
Dark Gray		Jet-LH BU-90	DC(±) AC			145-210 155-225	180-280 200-290	230-360 255-375			
Dark Gray		Mangjet®	DC(±) AC			120-180 135-230	160-260 165-285	200-350 220-385			
Dark Gray		Wearweld®	DC(+) AC				110-275 125-275	150-400 200-400			



IDENTIFICATION

Look for Lincoln's symbol of dependability.

IDENTIFICATION DOT

AWS Class (or NAME) on each electrode. Exceptions: 5/64" Stainweld, Faceweld 1 & 12, Aluminweld.

* Means registered Trademark of The Lincoln Electric Company.

* Has identification dot on coating.

The electrodes under the shaded portions of this chart will operate on the AC-225-GLM Arc Welder. Be careful of abusing the duty cycle with large electrodes which will overheat and damage the machine.

			
WARNING	<ul style="list-style-type: none"> ● Do not touch electrically live parts or electrode with skin or wet clothing. ● Insulate yourself from work and ground. 	<ul style="list-style-type: none"> ● Keep flammable materials away. 	<ul style="list-style-type: none"> ● Wear eye, ear and body protection.
Spanish AVISO DE PRECAUCION	<ul style="list-style-type: none"> ● No toque las partes o los electrodos bajo carga con la piel o ropa mojada. ● Aislese del trabajo y de la tierra. 	<ul style="list-style-type: none"> ● Mantenga el material combustible fuera del área de trabajo. 	<ul style="list-style-type: none"> ● Protéjase los ojos, los oídos y el cuerpo.
French ATTENTION	<ul style="list-style-type: none"> ● Ne laissez ni la peau ni des vêtements mouillés entrer en contact avec des pièces sous tension. ● Isolez-vous du travail et de la terre. 	<ul style="list-style-type: none"> ● Gardez à l'écart de tout matériel inflammable. 	<ul style="list-style-type: none"> ● Protégez vos yeux, vos oreilles et votre corps.
German WARNUNG	<ul style="list-style-type: none"> ● Berühren Sie keine stromführenden Teile oder Elektroden mit Ihrem Körper oder feuchter Kleidung! ● Isolieren Sie sich von den Elektroden und dem Erdboden! 	<ul style="list-style-type: none"> ● Entfernen Sie brennbares Material! 	<ul style="list-style-type: none"> ● Tragen Sie Augen-, Ohren- und Körperschutz!
Portuguese ATENÇÃO	<ul style="list-style-type: none"> ● Não toque partes elétricas e electrodos com a pele ou roupa molhada. ● Isole-se da peça e terra. 	<ul style="list-style-type: none"> ● Mantenha inflamáveis bem guardados. 	<ul style="list-style-type: none"> ● Use proteção para a vista, ouvido e corpo.
Japanese 注意事項	<ul style="list-style-type: none"> ● 通電中の電気部品、又は溶材にヒフやぬれた布で触れないこと。 ● 施工物やアースから身体が絶縁されている様にして下さい。 	<ul style="list-style-type: none"> ● 燃えやすいものの側での溶接作業は絶対にはなりません。 	<ul style="list-style-type: none"> ● 目、耳及び身体に保護具をして下さい。
Chinese 警告	<ul style="list-style-type: none"> ● 皮膚或濕衣物切勿接觸帶電部件及鋸條。 ● 使你自己與地面和工件絕緣。 	<ul style="list-style-type: none"> ● 把一切易燃物品移離工作場所。 	<ul style="list-style-type: none"> ● 佩戴眼、耳及身體勞動保護用具。
Korean 위험	<ul style="list-style-type: none"> ● 전도체나 용접봉을 젖은 헝겍 또는 피부로 절대 접촉치 마십시오. ● 모재와 접지를 접촉치 마십시오. 	<ul style="list-style-type: none"> ● 인화성 물질을 접근 시키지 마시오. 	<ul style="list-style-type: none"> ● 눈, 귀와 몸에 보호장구를 착용하십시오.
Arabic تحذير	<ul style="list-style-type: none"> ● لا تلمس الاجزاء التي يسري فيها التيار الكهربائي أو الألكترود بجدد الجسم أو بالملابس المبللة بالماء. ● ضع عازلا على جسمك خلال العمل. 	<ul style="list-style-type: none"> ● ضع المواد القابلة للاشتعال في مكان بعيد. 	<ul style="list-style-type: none"> ● ضع أدوات وملابس واقية على عينيك وأذنيك وجسمك.

READ AND UNDERSTAND THE MANUFACTURER'S INSTRUCTION FOR THIS EQUIPMENT AND THE CONSUMABLES TO BE USED AND FOLLOW YOUR EMPLOYER'S SAFETY PRACTICES.

SE RECOMIENDA LEER Y ENTENDER LAS INSTRUCCIONES DEL FABRICANTE PARA EL USO DE ESTE EQUIPO Y LOS CONSUMIBLES QUE VA A UTILIZAR, SIGA LAS MEDIDAS DE SEGURIDAD DE SU SUPERVISOR.

LISEZ ET COMPRENEZ LES INSTRUCTIONS DU FABRICANT EN CE QUI REGARDE CET EQUIPMENT ET LES PRODUITS A ETRE EMPLOYES ET SUIVEZ LES PROCEDURES DE SECURITE DE VOTRE EMPLOYEUR.

LESEN SIE UND BEFOLGEN SIE DIE BETRIEBSANLEITUNG DER ANLAGE UND DEN ELEKTRODENEINSATZ DES HERSTELLERS. DIE UNFALLVERHÜTUNGSVORSCHRIFTEN DES ARBEITGEBERS SIND EBENFALLS ZU BEACHTEN.

			
<ul style="list-style-type: none"> ● Keep your head out of fumes. ● Use ventilation or exhaust to remove fumes from breathing zone. 	<ul style="list-style-type: none"> ● Turn power off before servicing. 	<ul style="list-style-type: none"> ● Do not operate with panel open or guards off. 	WARNING
<ul style="list-style-type: none"> ● Los humos fuera de la zona de respiración. ● Mantenga la cabeza fuera de los humos. Utilice ventilación o aspiración para gases. 	<ul style="list-style-type: none"> ● Desconectar el cable de alimentación de poder de la máquina antes de iniciar cualquier servicio. 	<ul style="list-style-type: none"> ● No operar con panel abierto o guardas quitadas. 	Spanish AVISO DE PRECAUCION
<ul style="list-style-type: none"> ● Gardez la tête à l'écart des fumées. ● Utilisez un ventilateur ou un aspirateur pour ôter les fumées des zones de travail. 	<ul style="list-style-type: none"> ● Débranchez le courant avant l'entretien. 	<ul style="list-style-type: none"> ● N'opérez pas avec les panneaux ouverts ou avec les dispositifs de protection enlevés. 	French ATTENTION
<ul style="list-style-type: none"> ● Vermeiden Sie das Einatmen von Schweißrauch! ● Sorgen Sie für gute Be- und Entlüftung des Arbeitsplatzes! 	<ul style="list-style-type: none"> ● Strom vor Wartungsarbeiten abschalten! (Netzstrom völlig öffnen; Maschine anhalten!) 	<ul style="list-style-type: none"> ● Anlage nie ohne Schutzgehäuse oder Innenschutzverkleidung in Betrieb setzen! 	German WARNUNG
<ul style="list-style-type: none"> ● Mantenha seu rosto da fumaça. ● Use ventilação e exaustão para remover fumo da zona respiratória. 	<ul style="list-style-type: none"> ● Não opere com as tampas removidas. ● Desligue a corrente antes de fazer serviço. ● Não toque as partes elétricas nuas. 	<ul style="list-style-type: none"> ● Mantenha-se afastado das partes moventes. ● Não opere com os painéis abertos ou guardas removidas. 	Portuguese ATENÇÃO
<ul style="list-style-type: none"> ● ヒュームから頭を離すようにして下さい。 ● 換気や排煙に十分留意して下さい。 	<ul style="list-style-type: none"> ● メンテナンス・サービスに取りかかる際には、まず電源スイッチを必ず切して下さい。 	<ul style="list-style-type: none"> ● パネルやカバーを取り外したままで機械操作をしないで下さい。 	Japanese 注意事項
<ul style="list-style-type: none"> ● 頭部遠離煙霧。 ● 在呼吸區使用通風或排風器除煙。 	<ul style="list-style-type: none"> ● 維修前切斷電源。 	<ul style="list-style-type: none"> ● 儀表板打開或沒有安全罩時不準作業。 	Chinese 警告
<ul style="list-style-type: none"> ● 얼굴로부터 용접가스를 멀리하십시오. ● 호흡지역으로부터 용접가스를 제거하기 위해 가스제거기나 통풍기를 사용하십시오. 	<ul style="list-style-type: none"> ● 보수전에 전원을 차단하십시오. 	<ul style="list-style-type: none"> ● 판넬이 열린 상태로 작동치 마십시오. 	Korean 위험
<ul style="list-style-type: none"> ● ابعء رأسك بعيداً عن الدخان. ● استعمل التهوية أو جهاز ضغط الدخان للخارج لكي تبعد الدخان عن المنطقة التي تتنفس فيها. 	<ul style="list-style-type: none"> ● اقطع التيار الكهربائي قبل القيام بأية صيانة. 	<ul style="list-style-type: none"> ● لا تشغيل هذا الجهاز اذا كانت الاغطية الحديدية الواقية ليست عليه. 	Arabic تحذير

LEIA E COMPREENDA AS INSTRUÇÕES DO FABRICANTE PARA ESTE EQUIPAMENTO E AS PARTES DE USO, E SIGA AS PRÁTICAS DE SEGURANÇA DO EMPREGADOR.

使う機械や溶材のメーカーの指示書をよく読み、まず理解して下さい。そして貴社の安全規定に従って下さい。

請詳細閱讀並理解製造廠提供的說明以及應該使用的銀焊材料，並請遵守貴方的有關勞動保護規定。

이 제품에 동봉된 작업지침서를 숙지하시고 귀사의 작업자 안전수칙을 준수하시기 바랍니다.

اقرأ بتمعن وافهم تعليمات المصنع المنتج لهذه المعدات والمواد قبل استعمالها واتبع تعليمات الوقاية لصاحب العمل.

LIMITED WARRANTY

STATEMENT OF LIMITED WARRANTY

The Lincoln Electric Company (Lincoln) warrants to the end user (purchaser) of all new welding and cutting equipment, electrode and flux (collectively called the "Goods") that it will be free of defects in workmanship and material.

This warranty is void if Lincoln or its Authorized Service Facility finds that the equipment has been subjected to improper installation, improper care or abnormal operations.

WARRANTY PERIOD ⁽¹⁾ ⁽²⁾ ⁽³⁾

Lincoln will assume both the parts and labor expense of correcting defects during the full warranty period. All warranty periods date from the date of purchase to the original end user and are as follows:

7 Years

- Main power rectifiers on all non-inverter low frequency (50 and 60 Hz) type welders.

3 Years

- All Lincoln welding machines, wirefeeders and plasma cutting machines unless listed below.

2 Years

- Power Arc 5000
Ranger 10, Ranger 10-LX
Weldanpower 125, Weldanpower 150

1 Year

- AC-100
Invertec V100-S, Invertec V130-S, Invertec V200-T
Power Arc 4000
Pro-Cut 20

- All water coolers (internal or external models)

- All stick electrode, welding wire and flux.

- Arc welding and cutting robots and robotic controllers

- All Environmental Systems equipment, including portable units, central units, gun and cable assemblies and accessories. (Does not include consumable items listed under 30 day warranty.)

- All welding and cutting accessories including gun and cable assemblies, TIG and plasma torches, spool guns, wire feed modules, undercarriages, field installed options that are sold separately, unattached options, welding supplies, standard accessory sets, replacement parts, and Magnum products. (Does not include expendable parts listed under 30 day warranty)

30 Days

- All consumable items that may be used with the environmental systems described above. This includes hoses, filters, belts and hose adapters.
- Expendable Parts - Lincoln is not responsible for the replacement of any expendable part that is required due to normal wear.

CONDITIONS OF WARRANTY

TO OBTAIN WARRANTY COVERAGE:

The purchaser must contact Lincoln or Lincoln's Authorized Service Facility about any defect claimed under Lincoln's warranty.

Determination of warranty on welding and cutting equipment will be made by Lincoln or Lincoln's Authorized Service Facility.

WARRANTY REPAIR:

If Lincoln or Lincoln's Authorized Service Facility confirms the existence of a defect covered by this warranty, the defect will be corrected by repair or replacement at Lincoln's option.

At Lincoln's request, the purchaser must return, to Lincoln or its Authorized Service Facility, any "Goods" claimed defective under Lincoln's warranty.

FREIGHT COSTS:

The purchaser is responsible for shipment to and from the Lincoln Authorized Service Facility.

WARRANTY LIMITATIONS

Lincoln will not accept responsibility or liability for repairs made outside of a Lincoln Authorized Service Facility.

Lincoln's liability under this warranty shall not exceed the cost of correcting the defect of the Lincoln product.

Lincoln will not be liable for incidental or consequential damages (such as loss of business, etc.) caused by the defect or the time involved to correct the defect.

This written warranty is the only express warranty provided by Lincoln with respect to its products. Warranties implied by law such as the warranty of merchantability are limited to the duration of this limited warranty for the equipment involved.

This warranty gives the purchaser specific legal rights. The purchaser may also have other rights which vary from state to state.

⁽¹⁾ Equipment manufactured for the Lincoln Electric Company is subject to the warranty period of the original manufacturer.

⁽²⁾ All engines and engine accessories are warranted by the engine or engine accessory manufacturer and are not covered by this warranty.

⁽³⁾ SAE400 WELD N' AIR compressor is warranted by the compressor manufacturer and not covered by this warranty.



Dec, '97

World's Leader in Welding and Cutting Products

Premier Manufacturer of Industrial Motors

• Sales and Service through Subsidiaries and Distributors Worldwide •

Cleveland, Ohio 44117-1199 U.S.A. TEL: 216.481.8100 FAX: 216.486.1751 WEB SITE: www.lincolnelectric.com