

K2641-2 4 WHEEL STEERABLE TRAILER ASSEMBLY INSTRUCTIONS

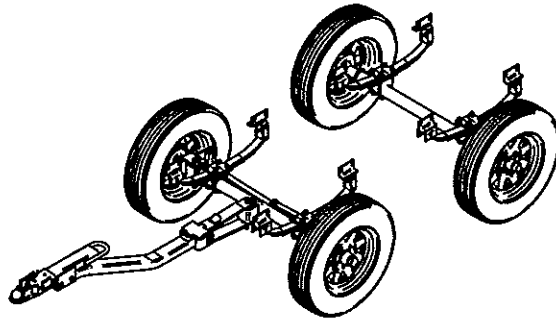

The K2642-2* trailer is designed for in-yard towing and off-road use only and is designed for use only with the following engine driven Lincoln welders:

- SAE 400, SAE 400 Severe Duty
- SAE 500, SAE 500 Severe Duty
- Vantage 300, Vantage 400, Vantage 400 CE, Vantage 500, Vantage 500 CE, Vantage 500-I, Air Vantage 500
- Big Red 500, Big Red 600

*Includes a DUO-HITCH™ (Patent Pending) 2" Ball / Lunette Eye combination hitch

DUO-HITCH™ is the property of the Lincoln Electric Company.
Trailer design is the property of Tri State Industries.

*IMPORTANT SAFETY NOTES:

HAVE ALL INSTALLATION, OPERATION, REPAIR, AND MAINTENANCE DONE BY QUALIFIED PERSONNEL.

The trailer is designed for off road, in-plant and yard towing. This trailer is not designed for on-road or highway use. Tow only with vehicles equipped for the weight and hitch type. Maximum recommended straight line towing speed is 15 mph on a flat surface. Reduce speed on turns and when negotiating uneven or angled road surfaces. Limit towing speeds to those at which the unit is stable. When towing, stop periodically and inspect hitch connections and trailer.

WARNING: UNSTABLE OR IMPROPERLY USED TRAILERS MAY CAUSE INJURY AND PROPERTY DAMAGE

- Follow instructions when assembling trailer and mounting welder to trailer. Do not overload trailer.
- Always drive at a speed at which the trailer is stable and does not sway.
- Inspect and maintain trailer, tow vehicle and hitch before towing.

TRAILER CHECKLIST: CHECK BEFORE TOWING TRAILER

- ✓ TRAILER CAPACITY FOR PAYLOAD
- ✓ HITCH AND CONNECTION TO TRAILER
- ✓ TIRES AND TIRE PRESSURE
- ✓ WHEELS - BEARINGS - LUGNUTS
- ✓ TRAILER LIGHT
- ✓ TOW VEHICLE AND CAPACITY
- ✓ WELDER FUEL SHUTOFF
- ✓ WELDER / TRAILER MOUNTING HARDWARE

LIMITED WARRANTY

Effective JANUARY 1, 2007

This warranty supersedes all previous Tri-State Industries warranties and is exclusive, with no other guarantees or warranties expressed or implied.

LIMITED WARRANTY – Tri-State Industries, Hammond Indiana warrants that all new and unused equipment furnished by Tri-State Industries is of merchantable quality, fit for the purpose intended, free from defect in workmanship, material and seller's design as of the time and place of delivery. Except as a result of the seller's own acts or recommendations, the foregoing warranties will not apply to any defect which has been solely caused by another's misuse, neglect, improper installation, improper operation, improper maintenance, repair or alteration, accident or unusual deterioration of the Products or parts thereof due to physical environment beyond the requirements of the Product specifications. No warranty is made by Tri-State Industries with respect to trade accessories or other items manufactured by others. Such trade accessories and other items are sold subject to the warranties of their respective manufacturers, if any.

In the case of Tri-State Industries breach of warranty or any other duty with respect to the quality of any goods, the exclusive remedies therefore shall be at Tri-State Industries: (1) repair (2) replacement (3) payment of or credit for the purchase price upon authorized return of the goods at Tri-State Industries risk and expense. Upon receipt of notice of apparent defect or failure, Tri-State Industries shall instruct the claimant on the warranty claim procedures to be followed. As a matter of general policy only, Tri-State Industries may honor an original end user's warranty claims with proof of purchase on warranted equipment in the event of failure resulting from a defect within one year of the purchase date by the end user.

Notification of any failure must be made in writing within 30 days of such failure. A copy of the invoice showing the date of sale must accompany products returned for authorized warranty repair or replacement. All equipment returned to Tri-State Industries for service must be properly packaged to guard against damage from shipping. Tri-State Industries will not be responsible for any damages resulting from negligent shipping practices/methods.

Normal surface transportation charges (both ways) for products returned for warranty repair or replacement will be borne by Tri-State Industries, except for products sold to foreign markets.

ANY EXPRESS WARRANTY NOT PROVIDED HEREIN AND ANY IMPLIED WARRANTY, GUARANTY, OR REPRESENTATION AS TO PERFORMANCE, AND ANY REMEDY FOR BREACH OF CONTRACT WHICH, BUT FOR THIS PROVISION, MIGHT ARISE BY IMPLICATION, OPERATION OF LAW, CUSTOM OF TRADE, OR COURSE OF DEALING, INCLUDING ANY IMPLIED WARRANTY OF MERCHANTABILITY OR OF FITNESS FOR PARTICULAR PURPOSE, WITH RESPECT TO ANY AND ALL EQUIPMENT FURNISHED BY TRI-STATE INDUSTRIES, IS EXCLUDED AND DISCLAIMED INCLUDING ANY AND ALL CONSEQUENTIAL DAMAGES BY TRI-STATE INDUSTRIES EXCEPT AS EXPRESSLY PROVIDED BY TRI-STATE INDUSTRIES IN WRITING.

TRI-STATE INDUSTRIES PRODUCTS ARE INTENDED FOR ULTIMATE PURCHASE BY END-USERS TRAINED AND EXPERIENCED IN THE USE AND MAINTENANCE OF TRAILER EQUIPMENT. TRI-STATE INDUSTRIES WILL NOT BE RESPONSIBLE FOR ANY DAMAGES RESULTING FROM THE END USERS NEGLIGENCE OR INEXPERIENCE IN USING THE EQUIPMENT FOR THE PURPOSE INTENDED

TRI-STATE INDUSTRIES, INC
4923 Columbia Avenue
Hammond, IN 46327
(219) 933-1710
(219) 933-1719

TRAILER OPERATING INFORMATION

TRAILER HITCH

The use of an incorrect size or rating of trailer hitches can cause a trailer to break loose from the tow vehicle. Use the following tips to insure this does not occur:

1. Be sure the towing vehicle hitch is correct type, size and trailer rating to match coupler.
2. Be sure the hitch is properly installed onto towing vehicle.
3. On optional ball couplers, always insert hitch safety pin before towing.
4. Make sure hitch and ball are properly sized and match each other.

TOWING

1. Towing any trailer requires special awareness because of the changed driving situation.
2. When towing, it takes longer to start, stop and turn – use training and practice to avoid accidents.
3. Turning a steerable trailer can present new problems – slow down and plan ahead.
4. **Do not under any circumstances, back up with a steerable trailer connected to towing vehicle**
5. Require each driver to be fully trained and experienced in trailer towing.
6. Insure that the vehicle used for towing is capable of handling the load.
7. Insure the towing vehicle hitch is the correct type, size, and rating to match coupler.
8. Be sure that the trailer is fully prepared and connected to the towing vehicle.
9. Drive at speeds which do not exceed 15 mph.
10. Trailer instability/sway is more likely to occur as speed increases.
11. Reduce speed when negotiating potholes, speed bumps and uneven road surfaces.

TRAILER DECOUPLING, AND DRAWBAR LOCK PROCEDURES

Use the following procedures to properly chock trailer wheels:

1. Chock in direction of grade.
2. Position chock snugly behind tire.
3. Place chock square to the tire.
4. Tap chock into place.
5. For added protection, chock both sides of tire.
6. Trailer may now be decoupled from the towing vehicle

This trailer is equipped with an automatically engaging drawbar lock when the drawbar is raised to the vertical position.

To engage the drawbar lock, raise the drawbar slightly passed the vertical position until the latch drops into the receiver and then slowly lower until the lock catches.

To unlock the drawbar, push forward on the drawbar, lift the drawbar latch up with a hand or a foot and then lower the drawbar.

TRAILER OPERATING INFORMATION CONTINUED

TIRES

Incorrect torque on lug nuts, incorrect tire pressure, or improper bearing maintenance can cause loss of control resulting in serious injury and equipment damage. Use the following maintenance tips to insure proper trailer function:

1. Recheck lug nut torque after first 50 miles (80 km) and once each year or every 12,000 miles (19,500 km) thereafter, whichever comes first.
2. When checking lug nuts, keep them clean, dry and free from lubrication.
3. Check and repack wheel bearings once a year or every 12,000 miles (19,500 km), whichever comes first.
4. Maintain correct tire pressure according to sidewall data on tire. Under inflation is the most common cause to tire trouble.
5. Check tires for wear every six months.
6. Use only replacement tires of the same size, rating and capacity.

WHEEL BEARINGS

Every 12,000 miles (19,500 km), check wheel bearings. Repack if necessary using a quality lithium based extreme pressure grease such as Lubriplate[®] No. 1552. Repacking two hubs will take approximately 4oz.

To prevent injury and damage, check and repack wheel bearings once a year or every 12,000 miles (19,500 km), which ever comes first.

Use proper equipment to lift and support unit.

Do not put any body part under trailer while lifting or performing maintenance.

NOTE: TORQUE WHEEL BEARINGS WHENEVER HUB NUT IS REMOVED OR HUB IS TOO LOOSE. TORQUE HUB NUT TO 25 ft-lb, THEN BACK OFF NUT 1/8 TO 1/4 TURN TO LINE UP COTTER KEY HOLE IN SPINDLE WITH SLOT IN CASTLE NUT.

OVERLOADING

Do not overload the trailer; overloading can cause serious injury or equipment damage. Use the following tips to insure this does not occur;

1. Gross Vehicle Weight Rating (GVWR) is the maximum total trailer weight with the engine driven welder and equipment, such as tools, cables, shielding and gas cylinder installed.
2. Gross Axle Weight Rating (GAWR) is the maximum load-bearing capacity of the axle.
3. Use gross trailer weight to select a proper towing vehicle.

TRAILER SUBASSEMBLIES, COMPONENTS, AND KITS				Quantity	Available service parts
KIT#	BAG#	SUBASSEMBLY# / COMPONENT#	DESCRIPTION	K2641-2	
		Z-9HC-BLN	Duo-Hitch Assembly	1	X
		Z-9AX-DRW	Drawbar Assembly	1	X
		L9957	Adapter Frame Assembly	1	X
		Z-8TO-BK22	Bearing Replacement Kit for Front Steerable Axle (1 set)**	-	X
		Z-8TO-BK11	Bearing Replacement Kit for Rear Idler Axle (1 set)**	-	X
		Z-9AX-TRUN-L	Trunnion Assembly, left hand	-	X
		Z-9AX-TRUN-R	Trunnion Assembly, right hand	-	X
		Z-9AX-SLK	Steering Linkage Subassembly	1	X
		Z-9AX-STR-L	Front Steerable Axle Assembly	1	X
		Z-9AX-TOL	Rear Idler Axle Assembly, 3500# Capacity	1	X
		Z-9AX-S02	Spring, 3 leaf, Double eye, 25.25 Centers, 1250# Capacity	4	X
		A-9TO-13B	Tires, B78-13B	4	X
1	B-BAG-LIN5		Duo-Hitch mounting hardware	1	X
		B-BLT-H18	1/2-13 Xx 4-1/2 HH Grade 5 Zinc Plated	2	
		B-NUT-HST	1/2-13 Nylock Nut	2	
		B-FLW-H00	1/2 Flat Washer	2	
2	B-BAG-LIN6		Latchbar to drawbar mounting hardware	1	X
		Z-9AX-LTCH	Drawbar Latch	1	
		B-BLT-H12	1/2-13 x 2-1/2 Grade 2 Hex Head Bolt	1	
		B-NUT-HST	1/2-13 Nylock Nut	1	
3	B-BAG-LIN7		Steering linkage to drawbar mounting hardware	1	X
		B-LNT-J00	5/8-11 Nylon Insert Locknut (Heavy) Grade 5 Zinc	2	
		B-BLT-J23	5/8-11 x 6-1/2 Hex Head Zinc Grade 5 Bolt	2	
		B-FLW-L02	11/16 ID x 1-3/4 OD x 1/8 Washer, Zinc	4	
		Z-8AX-D31	3/4 ID x 2-1/4 OD x 1/8 Bronze Washer	4	
		Z-8AX-BSH	41/64 ID x 3 OD x 3/4 HRS Bushing	4	
4	B-BAG-LIN8		Spring to spring hanger assembly mounting hardware	1	X
		B-SHK-BLT	Shackle Bolt	12	
		B-SHK-NUT	Shackle Nut	12	
		B-SHK-2WH	Shackle Link	8	
5	B-BAG-LIN9		Attaches steerable and idler axles to springs	1	X
		Z-8TP-002	Tie Plates	4	
		Z-8AX-TPN	U-Bolt Stacked Nuts	16	
		Z-UBT-TP2	2-3/8 Dia U-Bolt	8	
6	B-BAG-LIN10		Attaches spring hanger assemblies to welder	1	X
		B-BLT-H18	1/2-13 x 4-1/2 HH Grade 5 Zinc Plated	16	
		B-NUT-HST	1/2-13 Nylock Nut	16	
		B-FLW-H00	1/2 Flat Washer	16	
		S10509-146	Support Bracket	8	
7	B-BAG-LIN11		Spring hanger assemblies - right hand side*	1	X
		Z-9AX-RSH-R	Rear Spring Hanger Assembly - Right	2	
		Z-9AX-FSH-R	Front Spring Hanger Assembly - Right	2	
8	B-BAG-LIN12		Spring hanger assemblies - left hand side*	1	X
		Z-9AX-RSH-L	Rear Spring Hanger Assembly - Left	2	
		Z-9AX-FSH-L	Front Spring Hanger Assembly - Left	2	
9	B-BAG-LIN13		Attaches tie rods to spindle trunnions	1	X
		Z-8AX-WSH	9/16 IDx1-3/8 ODx3/32 Single "D" Brass Washer	1	
		B-FLW-I02	9/16 ID 1-3/8 OD x 3/32 Brass Washer	5	
		B-BLT-J20	1/2-13 x 4-1/2 HH Grade 5 Zinc Plated Bolt	2	
		B-NUT-HST	1/2-13 Nylon Insert Locknut Grade 5 Zinc Plated	2	
10	B-BAG-LIN14		Attaches wheels to idler and steerable axle hubs	1	X
		B-NUT-LUG	Cone Lug Nut	20	
11	B-BAG-LIN15		Attaches welder and spring hanger assemblies to adapter frame	1	X
		B-BLT-H07	1/2-13 x 1-1/4 HH Grade 5 Zinc Plated Bolt	16	
		M20645	Trailer Mounting Bracket	4	
		S-9225-64	Thread Forming Screw	16	
		B-BAG-LIN3	Machine Mounting Hardware Kit	1	
		B-BAG-LIN16	Machine Mounting Hardware Kit	1	
-	B-BAG-LIN3		Machine Mounting Hardware Kit	-	X
		B-BLT-H07	1/2-13 x 1-1/4 Grade 5 Zinc Bolt	4	
		B-FLW-H0L	1/2 ID x .850 OD LockWasher Steel Grade 5 (Zinc)	4	
		B-LNT-SPN	1/2-13 Speed Nut Zinc Plated	4	
-	B-BAG-LIN16		Machine Mounting Hardware Kit	-	X
		M20645-1	Trailer Mounting Bracket	4	
		S9225-64	Thread Forming Screw	16	

**Bearing replacement kit contains parts for one axle set: (4) Tapered roller bearings, (4) Tapered roller bearing cups, (2) Lip seals, (2) Dust covers, and (2) Cotter Keys.

ASSEMBLY PRECAUTIONS

When assembling the trailer insure that you wear approved safety glasses with side shields. Flying metal or dirt can injure eyes. Do not modify or change the trailer in any way, changes will void the warranty.

The following is a list of safety precautions that must be followed when assembling the trailer:

1. Read and follow instructions and safety precautions in this Owner's Manual. Use only genuine factory parts as replacements.
2. Tighten all parts, bolts, nuts and mounting hardware.

TOOLS REQUIRED

1. 1/2" (13mm) Socket (4 point)
2. 9/16" (14mm) Socket & Socket Wrench
3. 9/16" (14mm) Wrench
4. 3/4" (19mm) Socket & Socket Wrench
5. 3/4" (19mm) Wrench
6. 7/8" (23mm) Socket & Socket Wrench
7. 13/16" (21mm) Wrench
8. Torque Wrench with 0-100 ft-lb span
9. One pair of jack stands rated at 2 tons
10. Dead blow plastic mallet, 2-5 lbs

TRAILER MODEL K2641-2	
SPECIFICATION	DESCRIPTION
AXLE RATING	3500 lbs.
SPRING RATING (1250 lbs. ea.)	5000 lbs.
TIRE LOAD RATING "B" (1100 lbs. ea.)	4400 lbs.
GROSS AXLE WEIGHT RATING	3500 lbs.
GROSS VEHICLE WEIGHT RATING	3500 lbs.
NET PAYLOAD	3040 lbs.
ROAD CLEARANCE	7-1/2"
STANDARD TIRES	B78-13B
WEIGHT	NET 432 lbs.

STEP 1: ATTACH DUO-HITCH™ TO DRAWBAR

1. Position the DUO-HITCH™ over the drawbar as shown with preferred hitch type facing forward. Line up the hitch and drawbar holes and secure with hardware supplied in KIT#1. Torque the nuts to 85 ft-lb.

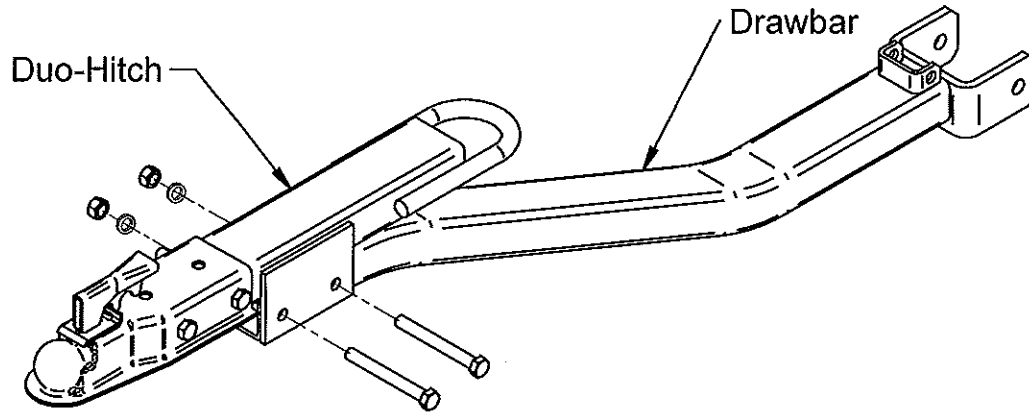

STEP 2: ATTACH DRAWBAR LATCH TO DRAWBAR ASSEMBLY

1. Bolt the drawbar latch to the drawbar as shown using hardware supplied in KIT#2 and tighten the nut until contact is made with the bracket. Ensure that threads are protruding from the end of the self-locking nut.

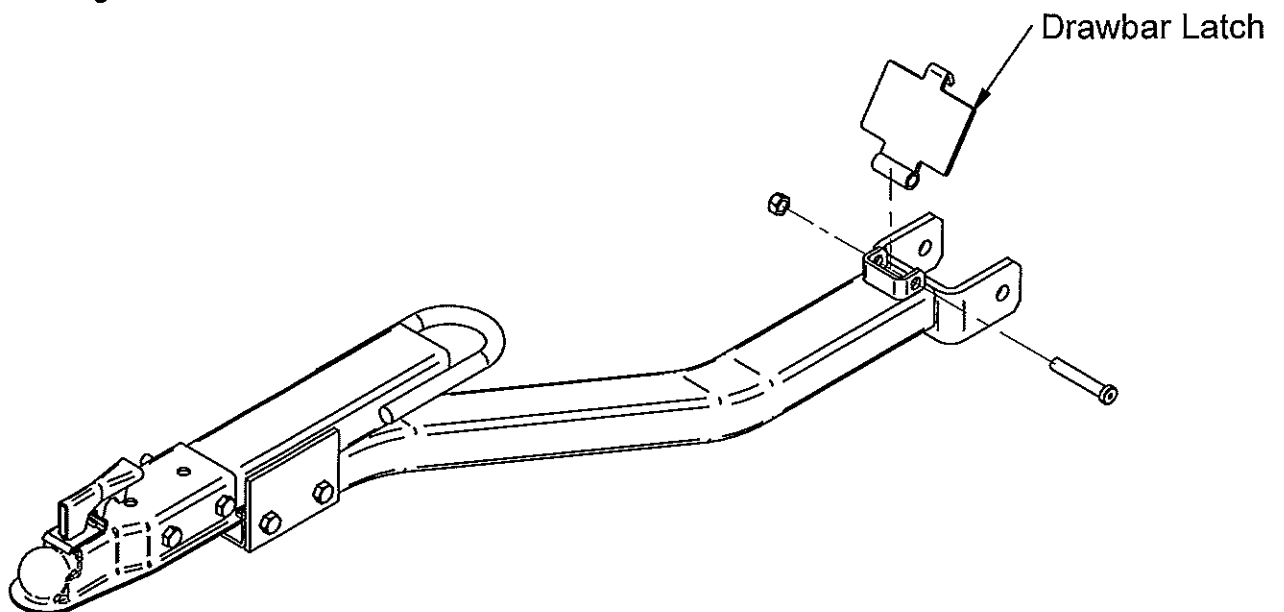

STEP 3: ATTACH THE SPRING HANGER ASSEMBLIES

1. (Figure A.) Using the hardware in KIT#6 attach the right hand spring hanger assemblies in KIT#7 to the welder or the adapter frame as shown. Repeat with left hand side spring hanger assemblies in KIT#8 and remaining hardware in KIT#6. Torque the nuts to 35 lb-ft.
2. (Figure B.) Use the flat washers and lock nuts from KIT#6 and the short bolts from KIT#11 to install the right hand spring hanger assemblies from KIT#7 and the left hand spring hanger assemblies from KIT#8. Torque the nuts to 35 lb-ft.
3. Using the hardware in KIT#4 attach the 4 leaf springs to spring hangers as shown below. Tap serrated bolts in all the way with the dead blow plastic mallet. Tighten nuts until zero clearance is achieved. It is important that these nuts not be over tightened to ensure articulation of the springs and shackles.

Figure A.
SAE 400, 400 S.D.
SAE 500, 500 S.D.

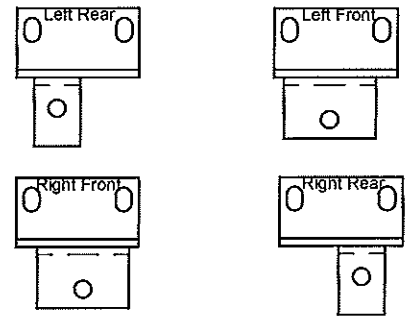
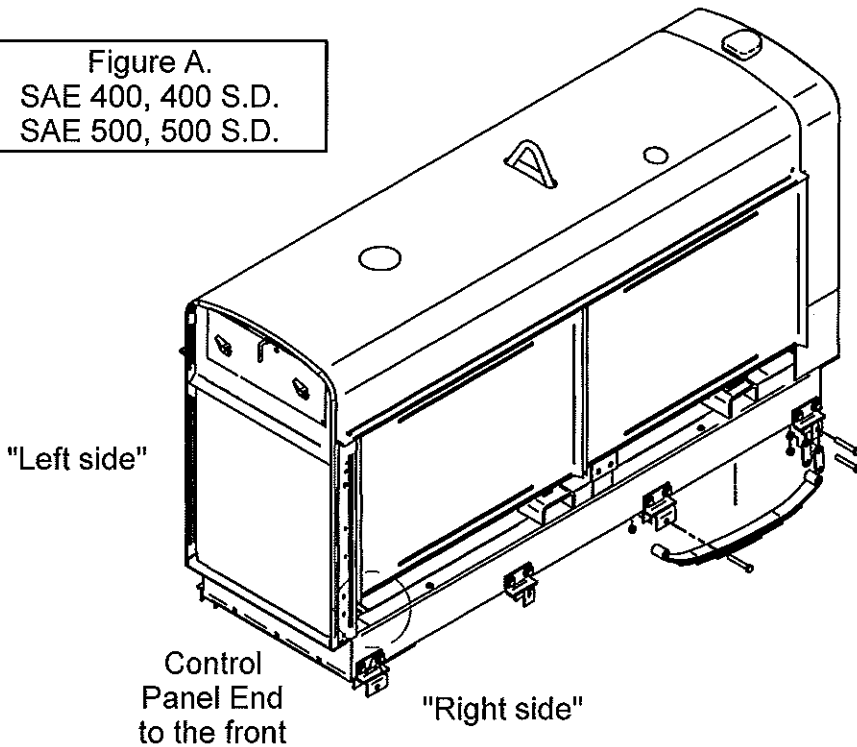

OUTBOARD LOOKING INBOARD

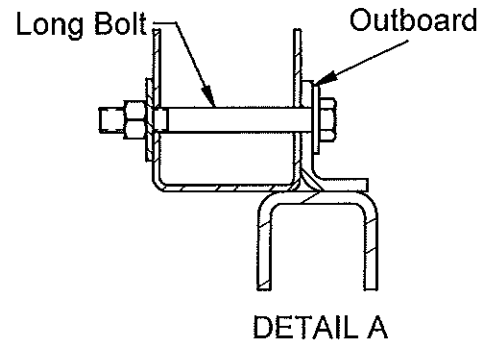
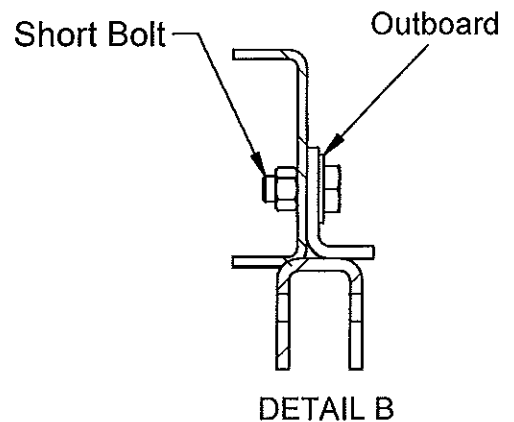
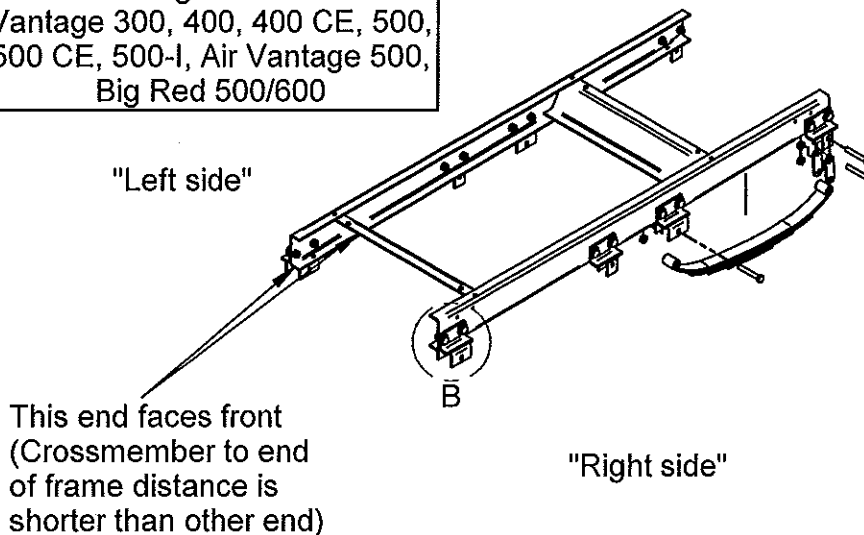
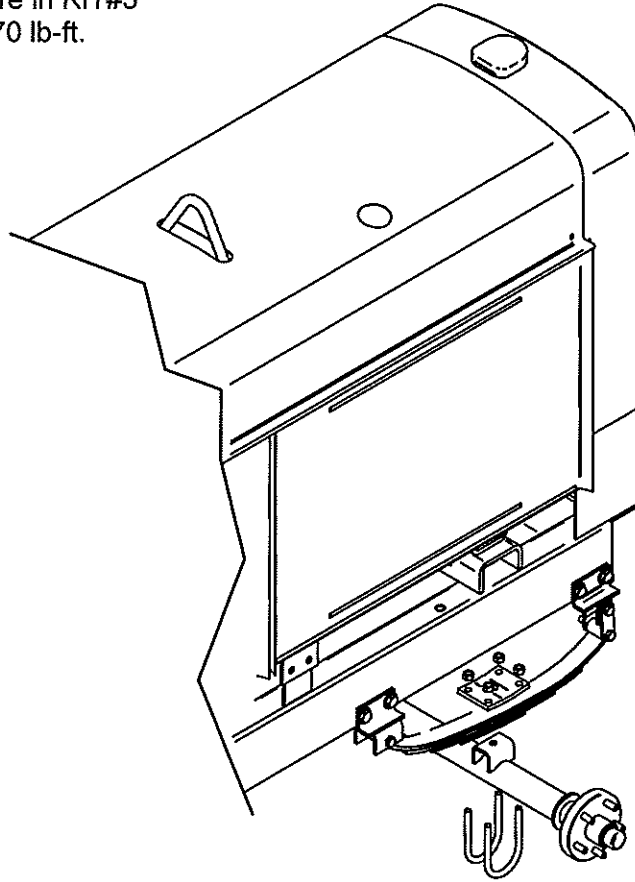

Figure B.
Vantage 300, 400, 400 CE, 500,
500 CE, 500-I, Air Vantage 500,
Big Red 500/600



STEP 4: ATTACH THE REAR IDLER AXLE TO REAR SPRINGS

1. Use the hardware in KIT#5
2. Torque nuts to 70 lb-ft.



STEP 5: ATTACH STEERING LINKAGE TO FRONT STEERABLE AXLE

1. Use the hardware in KIT#3.
2. Holding the hex bolt head with a wrench or socket, tighten nut until snug then back off ¼ turn.

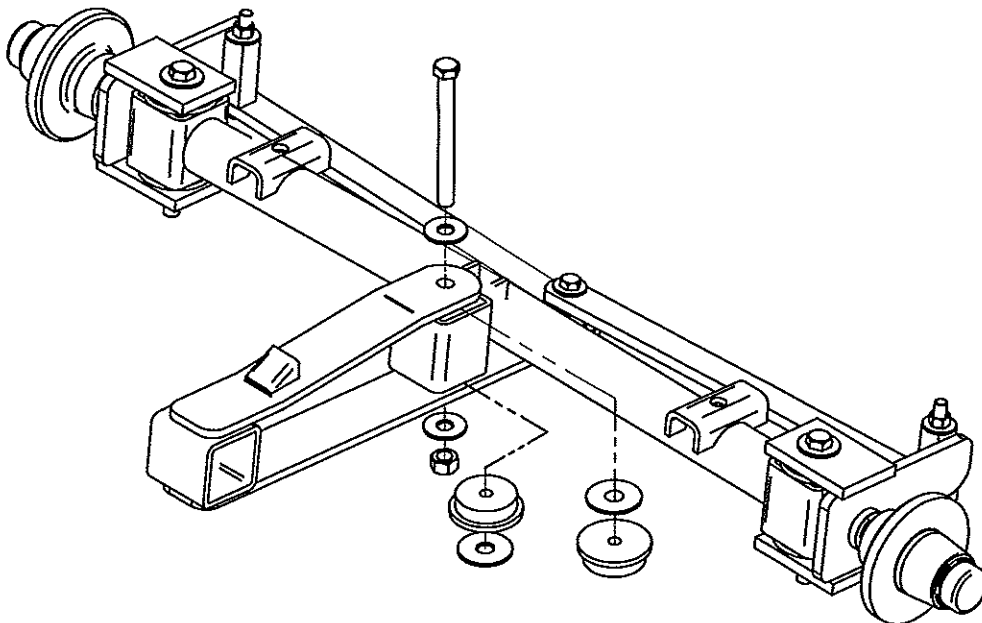

STEP 6: ATTACH TIE ROD ENDS TO SPINDLE TRUNNION STANDOFFS

1. Using jack stands, support axle under the springs.
2. Cut cable ties holding tie rods back, swing out and attach to spindle trunnion standoffs as shown using hardware in KIT#9. Note position of "D" washer.
3. Holding the hex bolt head with a wrench or socket, tighten both left and right nut until snug then back off ¼ turn.

STEP 7: ATTACH FRONT STEERABLE AXLE ASSEMBLY TO FRONT SPRINGS

1. With axle assembly still supported by jack stands attach steering linkage assembly to steerable front axle with hardware in KIT#5 as shown below.
2. Holding the hex bolt head with a wrench or socket, tighten nut until snug then back off ¼ turn.

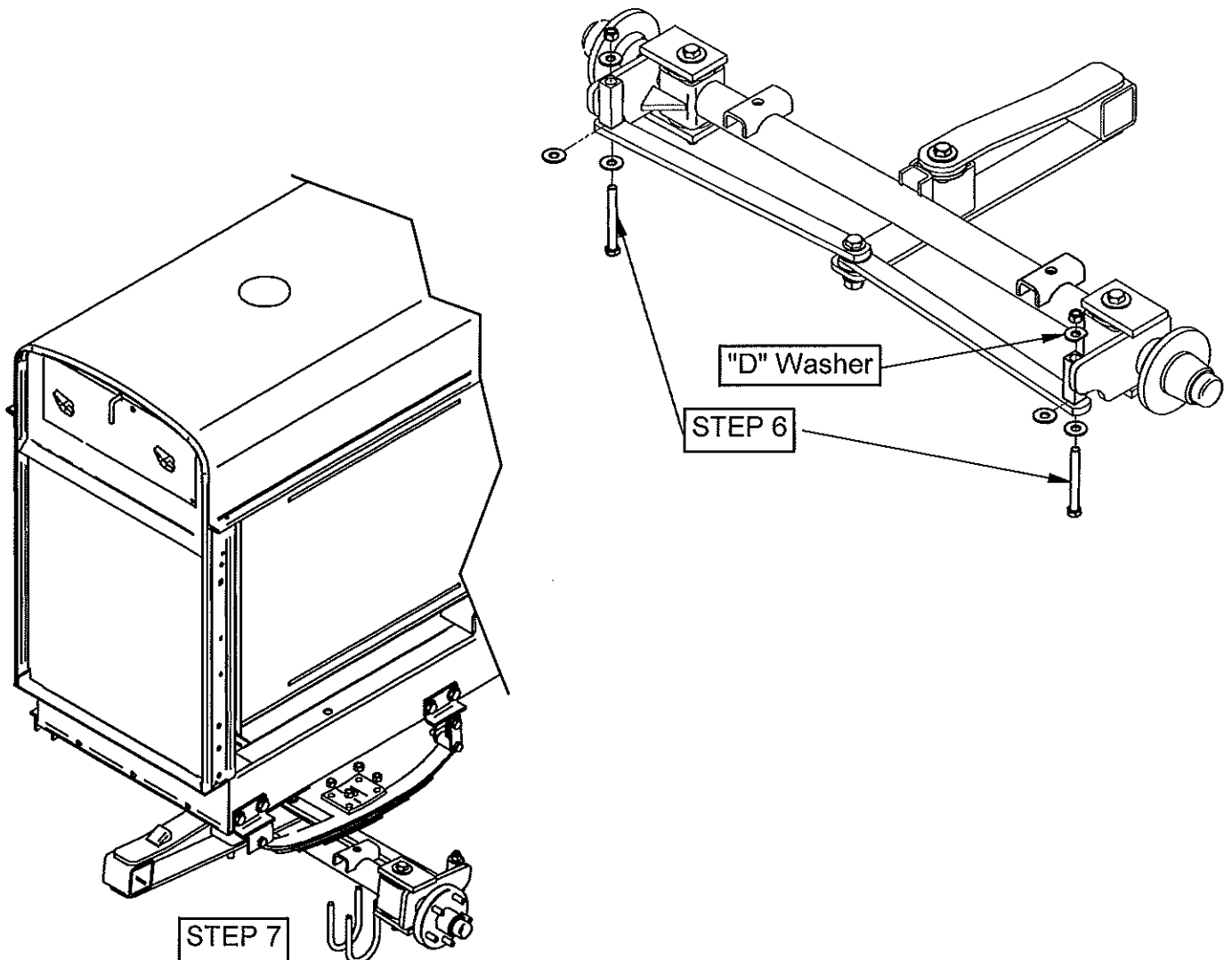

STEP 8: INSTALL WHEELS TO HUBS

1. Install wheels to hubs using 5 lug nuts per wheel with lug nuts in KIT#10. Torque to 70 lb-ft.
2. Ensure the drawbar is in the vertical and locked position
3. Lower welder / trailer assembly to the ground carefully and chock a minimum of 2 wheels both in the front and the rear of the tire.

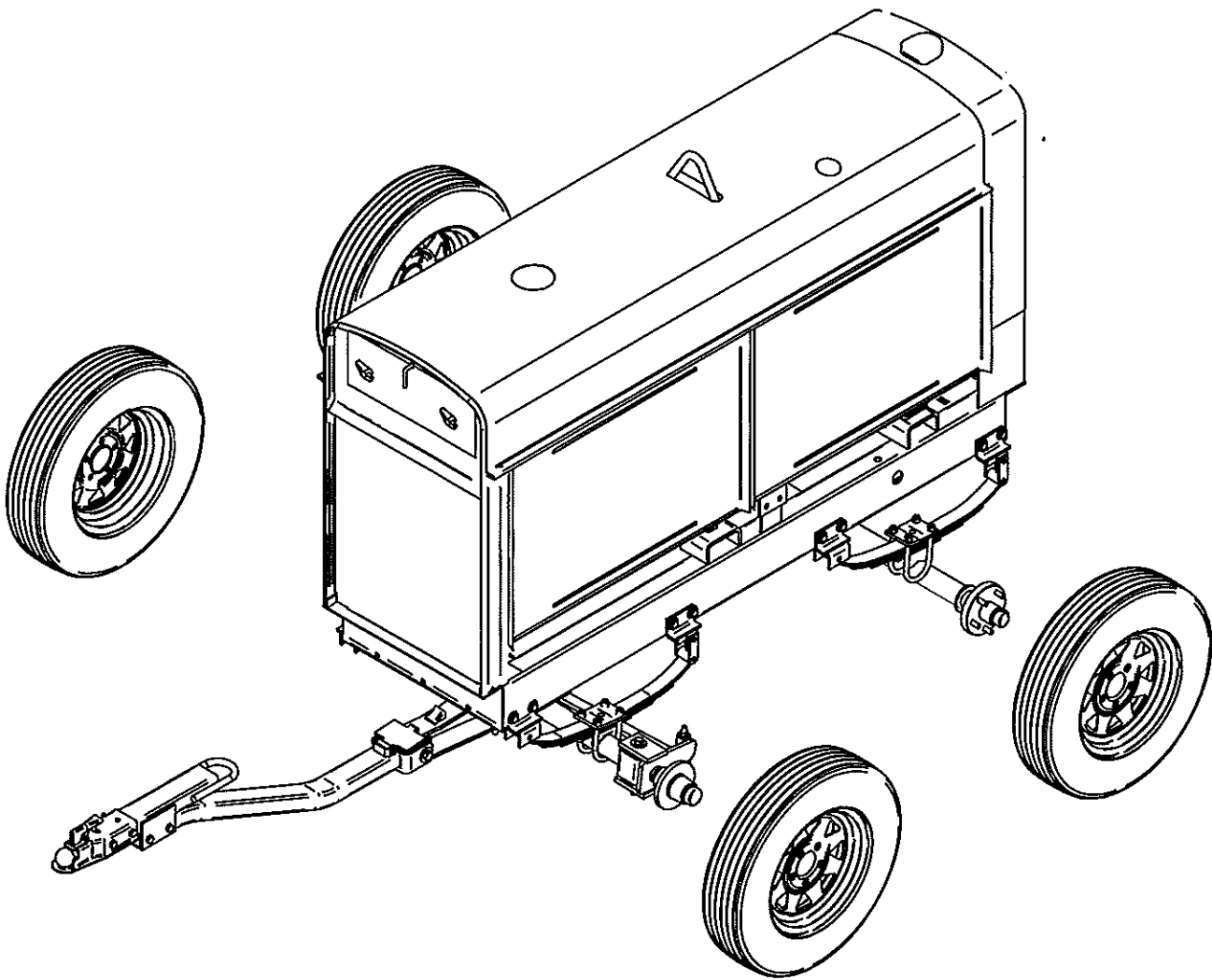

STEP 9: WELDER MOUNTING INSTRUCTIONS

Vantage 300 / Vantage 400 / Vantage 400 CE / Vantage 500 /
Vantage 500 CE / Vantage 500-I / Air Vantage 500 / Big Red 500 / Big Red 600

1. Ensure trailer is on level surface
2. Chock a minimum of two wheels in front of & behind each tire.
3. Using a suitable lifting device, position the welder approximately $\frac{1}{4}$ " – $\frac{1}{2}$ " above the top of the adapter frame cross members.
4. Remove the screws securing the 4 mounting feet to the welder
5. Lower welder and align the mounting feet holes with the holes in the adapter frame brackets where the mounting feet were just removed
6. Install bracket with thread forming screws in KIT#11
7. Torque bolts to 30-40 ft-lb.

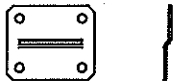

VANTAGE BRACKET

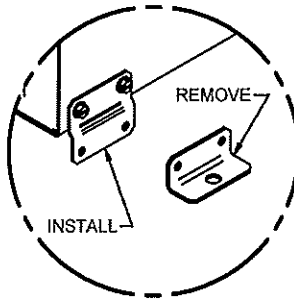

DETAIL D

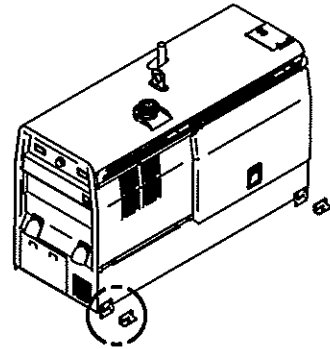

D

VANTAGE

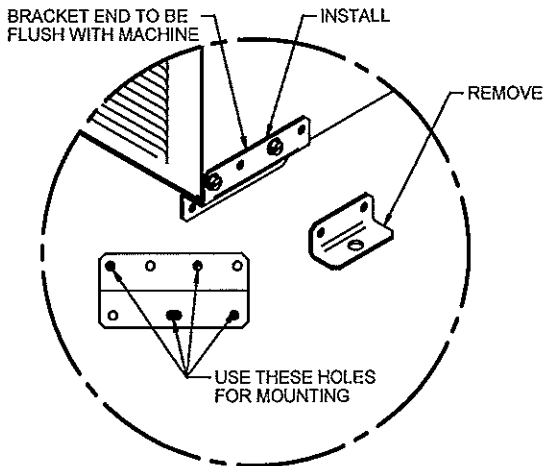

DETAIL E

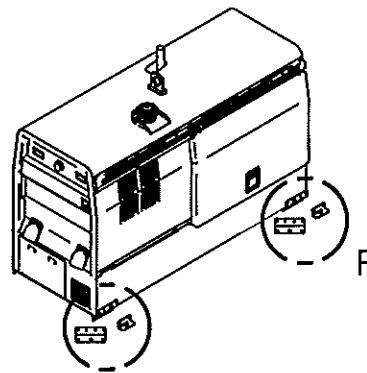

E

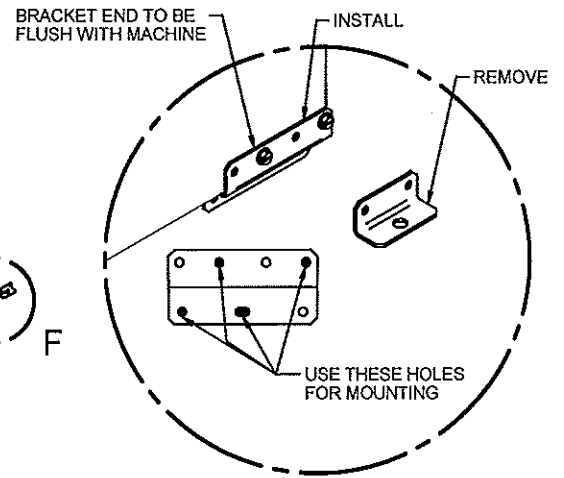

DETAIL F

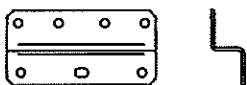

BIG RED BRACKET

BIG RED

STEP 9: WELDER MOUNTING INSTRUCTIONS - CONTINUED

Vantage 500, Air Vantage 500

1. Ensure the trailer is on a level surface
2. Chock a minimum of two wheels in front of & behind each tire.
3. Using a suitable lifting device, position the welder approximately $\frac{1}{4}$ " – $\frac{1}{2}$ " above the top of the adapter frame cross members.
4. Lower the welder, while at the same time aligning the holes in the adapter frame crossmembers with the speed nuts in the welder base. See figure below.
5. Install bolt and lock washer from the white hardware bag in KIT#11 in four locations shown and tighten to 55 lb-ft

FOR VANTAGE 500, AND AIR VANTAGE 500 MOUNTING, INSTALL SPEED NUTS FROM WHITE HARDWARE BAG IN KIT#11 IN THESE FOUR LOCATIONS

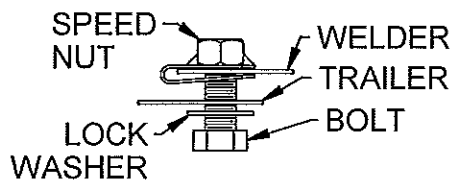
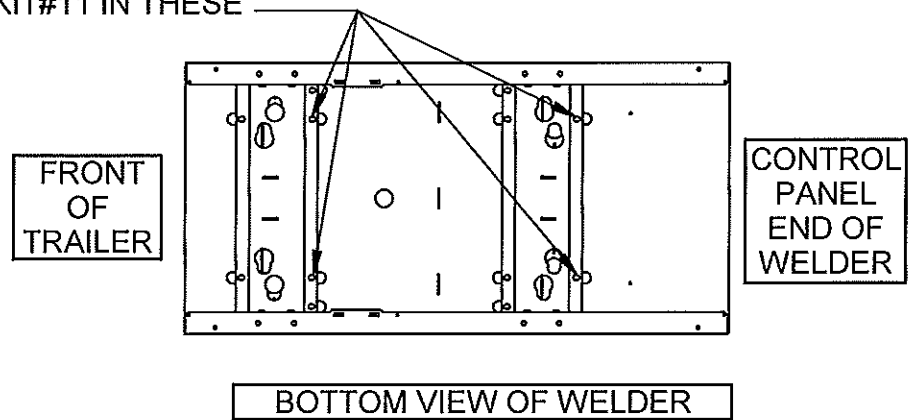

STEP 10: INSTALL DRAWBAR TO STEERING LINKAGE ASSEMBLY

1. Install drawbar to steering linkage with parts and hardware in KIT#3.
2. Start by placing both bushings in the steering linkage tubular steel section.
3. Install the washer which is just under the bolt head first, then push the bolt through the drawbar yoke until the bolt just clears the hole.
4. Add the bronze bearing washer to the inside end of the drawbar yoke.
5. Carefully take this assembly and line up with the steering linkage assembly.
6. Push bolt just through the other bushing and slide 2nd bronze bearing washer in between the bushing and drawbar yoke.
7. Push bolt the rest of the way through, add washer and self locking nut.
8. Tighten nut until snug and then back off ¼ turn.

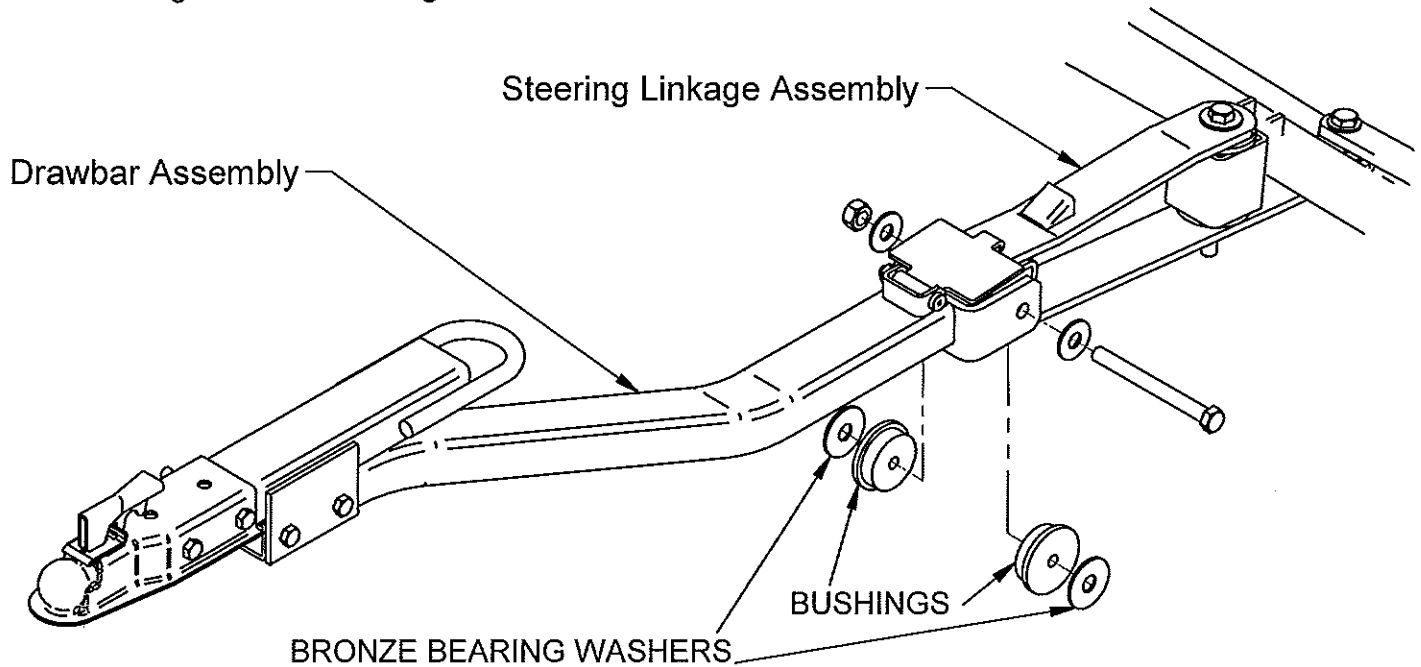

*******THIS COMPLETES THE INSTALLATION*******

GENERAL MAINTENANCE

Do not use the trailer if any part is damaged or not working properly. When performing maintenance, check trailer for worn, damaged, or non-working parts. Perform maintenance according to this manual.

If necessary, always replace any fastener with one of equal size, grade and type.

Be sure the grade marks on the replacement fastener match the original bolt.

The manufacturer's identification mark is not critical and does not matter for the replacement fastener.

Once a year, lubricate all moving parts on trailer with SAE20W oil. Lubricate more often if trailer is exposed to elements or subject to frequent off-road use.

Periodically double-check all nuts and bolts for tightness and condition.

