

# DIGITAL CRUISER WIRING DIAGRAM G5905-1 REV: B

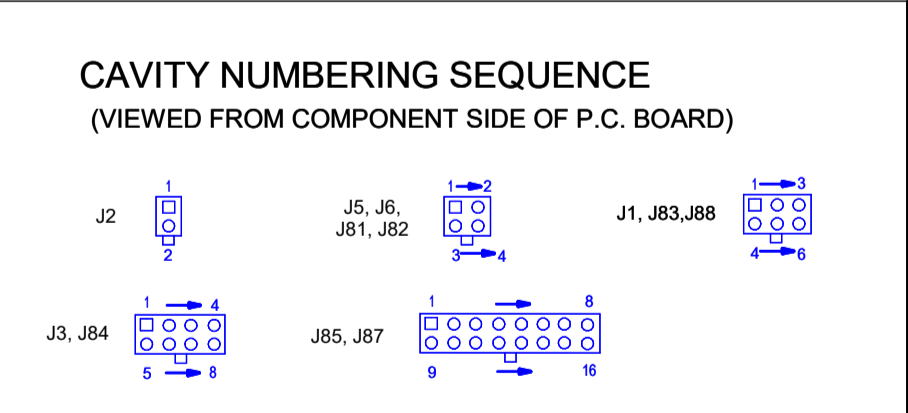
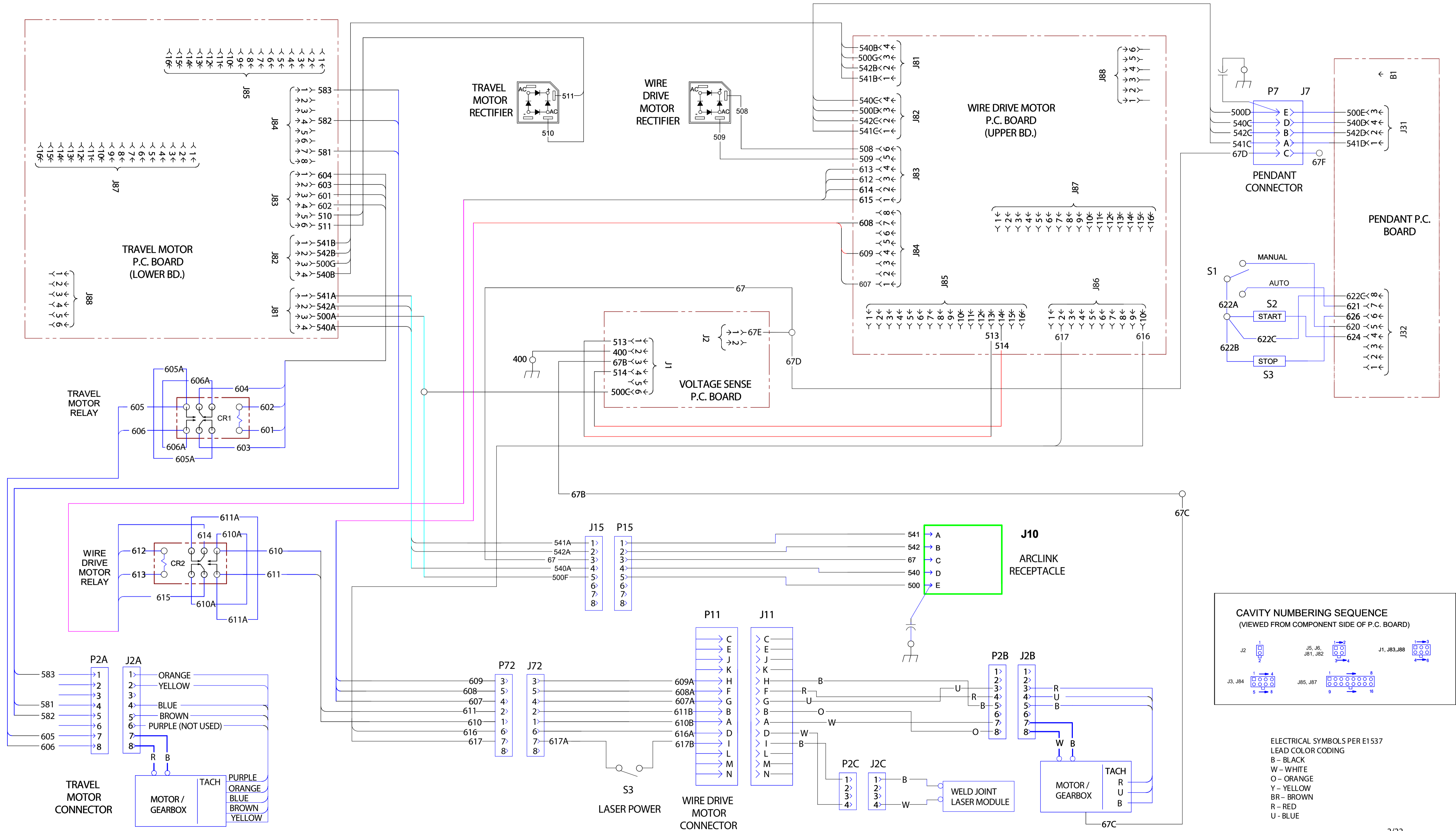

**ELECTRICAL SYMBOLS PER E1537**  
**LEAD COLOR CODING**  
 B - BLACK  
 W - WHITE  
 O - ORANGE  
 Y - YELLOW  
 BR - BROWN  
 R - RED  
 U - BLUE