

NOTE: This manual will cover most of the troubleshooting and repair procedures for the code numbers listed. Some variances may exist when troubleshooting/repairing later code numbers.

MOBIFLEX[®] 400-MS(/HE) MOBILE FILTER UNIT + LFA 3.1/4.1 EXTRACTION ARM

For use with machines having Code Numbers:

Mobiflex[®] 400-MS(/HE) Base Unit:
K1741-1 / K1741-2

Extraction Arm:
K2633-1 / K2633-2 / K2633-3 / K2633-4

SERVICE MANUAL



SAFETY DEPENDS ON YOU

Service and repair should be performed by only Lincoln Electric Factory Trained Personnel. Unauthorized repairs performed on this equipment may result in danger to the technician and machine operator and will invalidate your factory warranty. For your safety and to avoid Electrical Shock, please observe all safety notes and precautions detailed throughout this manual.

WARNING

This statement appears where the information must be followed exactly to avoid serious personal injury or loss of life.

CAUTION

This statement appears where the information must be followed to avoid minor personal injury or damage to this equipment.

KEEP YOUR HEAD OUT OF THE FUMES.

DON'T get too close to the arc. Use corrective lenses if necessary to stay a reasonable distance away from the arc.

READ and obey the Material Safety Data Sheet (MSDS) and the warning label that appears on all containers of welding materials.

USE ENOUGH VENTILATION or exhaust at the arc, or both, to keep the fumes and gases from your breathing zone and the general area.

IN A LARGE ROOM OR OUTDOORS, natural ventilation may be adequate if you keep your head out of the fumes (See below).

USE NATURAL DRAFTS or fans to keep the fumes away from your face.

If you develop unusual symptoms, see your supervisor. Perhaps the welding atmosphere and ventilation system should be checked.

**WEAR CORRECT EYE, EAR & BODY PROTECTION**

PROTECT your eyes and face with welding helmet properly fitted and with proper grade of filter plate (See ANSI Z49.1).



PROTECT your body from welding spatter and arc flash with protective clothing including woolen clothing, flame-proof apron and gloves, leather leggings, and high boots.

PROTECT others from splatter, flash, and glare with protective screens or barriers.

IN SOME AREAS, protection from noise may be appropriate.

BE SURE protective equipment is in good condition.

Also, wear safety glasses in work area AT ALL TIMES.

**SPECIAL SITUATIONS**

DO NOT WELD OR CUT containers or materials which previously had been in contact with hazardous substances unless they are properly cleaned. This is extremely dangerous.

DO NOT WELD OR CUT painted or plated parts unless special precautions with ventilation have been taken. They can release highly toxic fumes or gases.

Additional precautionary measures

PROTECT compressed gas cylinders from excessive heat, mechanical shocks, and arcs; fasten cylinders so they cannot fall.

BE SURE cylinders are never grounded or part of an electrical circuit.

REMOVE all potential fire hazards from welding area.

ALWAYS HAVE FIRE FIGHTING EQUIPMENT READY FOR IMMEDIATE USE AND KNOW HOW TO USE IT.





SECTION A: WARNINGS



CALIFORNIA PROPOSITION 65 WARNINGS

Diesel Engines

Diesel engine exhaust and some of its constituents are known to the State of California to cause cancer, birth defects, and other reproductive harm.

Gasoline Engines

The engine exhaust from this product contains chemicals known to the State of California to cause cancer, birth defects, or other reproductive harm.



ARC WELDING CAN BE HAZARDOUS. PROTECT YOURSELF AND OTHERS FROM POSSIBLE SERIOUS INJURY OR DEATH. KEEP CHILDREN AWAY. PACEMAKER WEARERS SHOULD CONSULT WITH THEIR DOCTOR BEFORE OPERATING.

Read and understand the following safety highlights. For additional safety information, it is strongly recommended that you purchase a copy of "Safety in Welding & Cutting - ANSI Standard Z49.1" from the American Welding Society, P.O. Box 351040, Miami, Florida 33135 or CSA Standard W117.2-1974. A Free copy of "Arc Welding Safety" booklet E205 is available from the Lincoln Electric Company, 22801 St. Clair Avenue, Cleveland, Ohio 44117-1199.

BE SURE THAT ALL INSTALLATION, OPERATION, MAINTENANCE AND REPAIR PROCEDURES ARE PERFORMED ONLY BY QUALIFIED INDIVIDUALS.



FOR ENGINE POWERED EQUIPMENT.

- 1.a. Turn the engine off before troubleshooting and maintenance work unless the maintenance work requires it to be running. 
- 1.b. Operate engines in open, well-ventilated areas or vent the engine exhaust fumes outdoors.
- 1.c. Do not add the fuel near an open flame welding arc or when the engine is running. Stop the engine and allow it to cool before refueling to prevent spilled fuel from vaporizing on contact with hot engine parts and igniting. Do not spill fuel when filling tank. If fuel is spilled, wipe it up and do not start engine until fumes have been eliminated. 

- 1.d. Keep all equipment safety guards, covers and devices in position and in good repair. Keep hands, hair, clothing and tools away from V-belts, gears, fans and all other moving parts when starting, operating or repairing equipment. 

- 1.e. In some cases it may be necessary to remove safety guards to perform required maintenance. Remove guards only when necessary and replace them when the maintenance requiring their removal is complete. Always use the greatest care when working near moving parts.

- 1.f. Do not put your hands near the engine fan. Do not attempt to override the governor or idler by pushing on the throttle control rods while the engine is running.

- 1.g. To prevent accidentally starting gasoline engines while turning the engine or welding generator during maintenance work, disconnect the spark plug wires, distributor cap or magneto wire as appropriate.

- 1.h. To avoid scalding, do not remove the radiator pressure cap when the engine is hot. 



ELECTRIC AND MAGNETIC FIELDS MAY BE DANGEROUS



- 2.a. Electric current flowing through any conductor causes localized Electric and Magnetic Fields (EMF). Welding current creates EMF fields around welding cables and welding machines
- 2.b. EMF fields may interfere with some pacemakers, and welders having a pacemaker should consult their physician before welding.
- 2.c. Exposure to EMF fields in welding may have other health effects which are now not known.
- 2.d. All welders should use the following procedures in order to minimize exposure to EMF fields from the welding circuit:
 - 2.d.1. Route the electrode and work cables together - Secure them with tape when possible.
 - 2.d.2. Never coil the electrode lead around your body.
 - 2.d.3. Do not place your body between the electrode and work cables. If the electrode cable is on your right side, the work cable should also be on your right side.
 - 2.d.4. Connect the work cable to the workpiece as close as possible to the area being welded.
 - 2.d.5. Do not work next to welding power source.



ELECTRIC SHOCK CAN KILL.



- 3.a. The electrode and work (or ground) circuits are electrically “hot” when the welder is on. Do not touch these “hot” parts with your bare skin or wet clothing. Wear dry, hole-free gloves to insulate hands.
- 3.b. Insulate yourself from work and ground using dry insulation. Make certain the insulation is large enough to cover your full area of physical contact with work and ground.

In addition to the normal safety precautions, if welding must be performed under electrically hazardous conditions (in damp locations or while wearing wet clothing; on metal structures such as floors, gratings or scaffolds; when in cramped positions such as sitting, kneeling or lying, if there is a high risk of unavoidable or accidental contact with the workpiece or ground) use the following equipment:

- Semiautomatic DC Constant Voltage (Wire) Welder.
 - DC Manual (Stick) Welder.
 - AC Welder with Reduced Voltage Control.
- 3.c. In semiautomatic or automatic wire welding, the electrode, electrode reel, welding head, nozzle or semiautomatic welding gun are also electrically “hot”.
 - 3.d. Always be sure the work cable makes a good electrical connection with the metal being welded. The connection should be as close as possible to the area being welded.
 - 3.e. Ground the work or metal to be welded to a good electrical (earth) ground.
 - 3.f. Maintain the electrode holder, work clamp, welding cable and welding machine in good, safe operating condition. Replace damaged insulation.
 - 3.g. Never dip the electrode in water for cooling.
 - 3.h. Never simultaneously touch electrically “hot” parts of electrode holders connected to two welders because voltage between the two can be the total of the open circuit voltage of both welders.
 - 3.i. When working above floor level, use a safety belt to protect yourself from a fall should you get a shock.
 - 3.j. Also see Items 6.c. and 8.



ARC RAYS CAN BURN.



- 4.a. Use a shield with the proper filter and cover plates to protect your eyes from sparks and the rays of the arc when welding or observing open arc welding. Headshield and filter lens should conform to ANSI Z87.1 standards.
- 4.b. Use suitable clothing made from durable flame-resistant material to protect your skin and that of your helpers from the arc rays.
- 4.c. Protect other nearby personnel with suitable, non-flammable screening and/or warn them not to watch the arc nor expose themselves to the arc rays or to hot spatter or metal.



FUMES AND GASES CAN BE DANGEROUS.



- 5.a. Welding may produce fumes and gases hazardous to health. Avoid breathing these fumes and gases. When welding, keep your head out of the fume. Use enough ventilation and/or exhaust at the arc to keep fumes and gases away from the breathing zone. **When welding with electrodes which require special ventilation such as stainless or hard facing (see instructions on container or MSDS) or on lead or cadmium plated steel and other metals or coatings which produce highly toxic fumes, keep exposure as low as possible and within applicable OSHA PEL and ACGIH TLV limits using local exhaust or mechanical ventilation. In confined spaces or in some circumstances, outdoors, a respirator may be required. Additional precautions are also required when welding on galvanized steel.**
- 5.b. The operation of welding fume control equipment is affected by various factors including proper use and positioning of the equipment, maintenance of the equipment and the specific welding procedure and application involved. Worker exposure level should be checked upon installation and periodically thereafter to be certain it is within applicable OSHA PEL and ACGIH TLV limits.
- 5.c. Do not weld in locations near chlorinated hydrocarbon vapors coming from degreasing, cleaning or spraying operations. The heat and rays of the arc can react with solvent vapors to form phosgene, a highly toxic gas, and other irritating products.
- 5.d. Shielding gases used for arc welding can displace air and cause injury or death. Always use enough ventilation, especially in confined areas, to insure breathing air is safe.
- 5.e. Read and understand the manufacturer’s instructions for this equipment and the consumables to be used, including the material safety data sheet (MSDS) and follow your employer’s safety practices. MSDS forms are available from your welding distributor or from the manufacturer.
- 5.f. Also see item 1.b.



WELDING AND CUTTING SPARKS CAN CAUSE FIRE OR EXPLOSION.

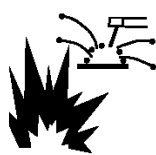

- 6.a. Remove fire hazards from the welding area. If this is not possible, cover them to prevent the welding sparks from starting a fire. Remember that welding sparks and hot materials from welding can easily go through small cracks and openings to adjacent areas. Avoid welding near hydraulic lines. Have a fire extinguisher readily available.
- 6.b. Where compressed gases are to be used at the job site, special precautions should be used to prevent hazardous situations. Refer to “Safety in Welding and Cutting” (ANSI Standard Z49.1) and the operating information for the equipment being used.
- 6.c. When not welding, make certain no part of the electrode circuit is touching the work or ground. Accidental contact can cause overheating and create a fire hazard.
- 6.d. Do not heat, cut or weld tanks, drums or containers until the proper steps have been taken to insure that such procedures will not cause flammable or toxic vapors from substances inside. They can cause an explosion even though they have been “cleaned”. For information, purchase “Recommended Safe Practices for the Preparation for Welding and Cutting of Containers and Piping That Have Held Hazardous Substances”, AWS F4.1 from the American Welding Society (see address above).
- 6.e. Vent hollow castings or containers before heating, cutting or welding. They may explode.
- 6.f. Sparks and spatter are thrown from the welding arc. Wear oil free protective garments such as leather gloves, heavy shirt, cuffless trousers, high shoes and a cap over your hair. Wear ear plugs when welding out of position or in confined places. Always wear safety glasses with side shields when in a welding area.
- 6.g. Connect the work cable to the work as close to the welding area as practical. Work cables connected to the building framework or other locations away from the welding area increase the possibility of the welding current passing through lifting chains, crane cables or other alternate circuits. This can create fire hazards or overheat lifting chains or cables until they fail.
- 6.h. Also see item 1.c.
- 6.i. Read and follow NFPA 51B “Standard for Fire Prevention During Welding, Cutting and Other Hot Work”, available from NFPA, 1 Batterymarch Park, PO box 9101, Quincy, Ma 022690-9101.
- 6.j. Do not use a welding power source for pipe thawing.



CYLINDER MAY EXPLODE IF DAMAGED.



- 7.a. Use only compressed gas cylinders containing the correct shielding gas for the process used and properly operating regulators designed for the gas and pressure used. All hoses, fittings, etc. should be suitable for the application and maintained in good condition.
- 7.b. Always keep cylinders in an upright position securely chained to an undercarriage or fixed support.
- 7.c. Cylinders should be located:
 - Away from areas where they may be struck or subjected to physical damage.
 - A safe distance from arc welding or cutting operations and any other source of heat, sparks, or flame.
- 7.d. Never allow the electrode, electrode holder or any other electrically “hot” parts to touch a cylinder.
- 7.e. Keep your head and face away from the cylinder valve outlet when opening the cylinder valve.
- 7.f. Valve protection caps should always be in place and hand tight except when the cylinder is in use or connected for use.
- 7.g. Read and follow the instructions on compressed gas cylinders, associated equipment, and CGA publication P-1, “Precautions for Safe Handling of Compressed Gases in Cylinders,” available from the Compressed Gas Association 1235 Jefferson Davis Highway, Arlington, VA 22202.



FOR ELECTRICALLY POWERED EQUIPMENT.



- 8.a. Turn off input power using the disconnect switch at the fuse box before working on the equipment.
- 8.b. Install equipment in accordance with the U.S. National Electrical Code, all local codes and the manufacturer’s recommendations.
- 8.c. Ground the equipment in accordance with the U.S. National Electrical Code and the manufacturer’s recommendations.

Refer to <http://www.lincolnelectric.com/safety> for additional safety information.



Welding Safety
Interactive Web Guide
for mobile devices

Get the free mobile app at
<http://gettag.mobi>

ELECTROMAGNETIC COMPATABILITY (EMC)

CONFORMANCE

Products displaying the CE mark are in conformity with European Community Council Directive of 3 May 1989 on the approximation of the laws of the Member States relating to electromagnetic compatibility (89/336/EEC). It was manufactured in conformity with a national standard that implements a harmonized standard: EN 60974-10 Electromagnetic Compatibility (EMC) Product Standard for Arc Welding Equipment. It is for use with other Lincoln Electric equipment. It is designed for industrial and professional use.

INTRODUCTION

All electrical equipment generates small amounts of electromagnetic emission. Electrical emission may be transmitted through power lines or radiated through space, similar to a radio transmitter. When emissions are received by other equipment, electrical interference may result. Electrical emissions may affect many kinds of electrical equipment; other nearby welding equipment, radio and TV reception, numerical controlled machines, telephone systems, computers, etc. Be aware that interference may result and extra precautions may be required when a welding power source is used in a domestic establishment.

INSTALLATION AND USE

The user is responsible for installing and using the welding equipment according to the manufacturer's instructions. If electromagnetic disturbances are detected then it shall be the responsibility of the user of the welding equipment to resolve the situation with the technical assistance of the manufacturer. In some cases this remedial action may be as simple as earthing (grounding) the welding circuit, see Note. In other cases it could involve construction of an electromagnetic screen enclosing the power source and the work complete with associated input filters. In all cases electromagnetic disturbances must be reduced to the point where they are no longer troublesome.

Note: The welding circuit may or may not be earthed for safety reasons according to national codes. Changing the earthing arrangements should only be authorized by a person who is competent to assess whether the changes will increase the risk of injury, e.g., by allowing parallel welding current return paths which may damage the earth circuits of other equipment.

ASSESSMENT OF AREA

Before installing welding equipment the user shall make an assessment of potential electromagnetic problems in the surrounding area. The following shall be taken into account:

- a. other supply cables, control cables, signaling and telephone cables; above, below and adjacent to the welding equipment;
- b. radio and television transmitters and receivers;
- c. computer and other control equipment;
- d. safety critical equipment, e.g., guarding of industrial equipment;
- e. the health of the people around, e.g., the use of pacemakers and hearing aids;
- f. equipment used for calibration or measurement
- g. the immunity of other equipment in the environment. The user shall ensure that other equipment being used in the environment is compatible. This may require additional protection measures;
- h. the time of day that welding or other activities are to be carried out.

The size of the surrounding area to be considered will depend on the structure of the building and other activities that are taking place. The surrounding area may extend beyond the boundaries of the premises.

METHODS OF REDUCING EMISSIONS

Mains Supply

Welding equipment should be connected to the mains supply according to the manufacturer's recommendations. If interference occurs, it may be necessary to take additional precautions such as filtering of the mains supply. Consideration should be given to shielding the supply cable of permanently installed welding equipment, in metallic conduit or equivalent. Shielding should be electrically continuous throughout its length. The shielding should be connected to the welding power source so that good electrical contact is maintained between the conduit and the welding power source enclosure.

Maintenance of the Welding Equipment

The welding equipment should be routinely maintained according to the manufacturer's recommendations. All access and service doors and covers should be closed and properly fastened when the welding equipment is in operation. The welding equipment should not be modified in any way except for those changes and adjustments covered in the manufacturer's instructions. In particular, the spark gaps of arc striking and stabilizing devices should be adjusted and maintained according to the manufacturer's recommendations.

Welding Cables

The welding cables should be kept as short as possible and should be positioned close together, running at or close to floor level.

Equipotential Bonding

Bonding of all metallic components in the welding installation and adjacent to it should be considered. However, metallic components bonded to the work piece will increase the risk that the operator could receive a shock by touching these metallic components and the electrode at the same time. The operator should be insulated from all such bonded metallic components.

Earthing of the Workpiece

Where the workpiece is not bonded to earth for electrical safety, not connected to earth because of its size and position, e.g., ships hull or building steelwork, a connection bonding the workpiece to earth may reduce emissions in some, but not all instances. Care should be taken to prevent the earthing of the work piece increasing the risk of injury to users, or damage to other electrical equipment. Where necessary, the connection of the workpiece to earth should be made by a direct connection to the work piece, but in some countries where direct connection is not permitted, the bonding should be achieved by suitable capacitance, selected according to national regulations.

Screening and Shielding

Selective screening and shielding of other cables and equipment in the surrounding area may alleviate problems of interference. Screening of the entire welding installation may be considered for special applications.

¹ Portions of the preceding text are contained in EN 60974-10: "Electromagnetic Compatibility (EMC) product standard for arc welding equipment."

As a rule of thumb, for many mild steel electrode, if the air is visibly clear and you are comfortable, then the ventilation is generally adequate for your work. The most accurate way to determine if the worker exposure does not exceed the applicable exposure limit for compounds in the fumes and gases is to have an industrial hygienist take and analyze a sample of the air you are breathing. This is particularly important if you are welding with stainless, hardfacing or Special Ventilation products. All Lincoln MSDS have a maximum fume guideline number. If exposure to total fume is kept below that number, exposure to all fume from the electrode (not coatings or plating on the work) will be below the TLV.

There are steps that you can take to identify hazardous substances in your welding environment. Read the product label and material safety data sheet for the electrode posted in the work place or in the electrode or flux container to see what fumes can be reasonably expected from use of the product and to determine if special ventilation is needed. Secondly, know what the base metal is and determine if there is any paint, plating, or coating that could expose you to toxic fumes and/or gases. Remove it from the metal being welded, if possible. If you start to feel uncomfortable, dizzy or nauseous, there is a possibility that you are being overexposed to fumes and gases, or suffering from oxygen deficiency. Stop welding and get some fresh air immediately. Notify your supervisor and co-workers so the situation can be corrected and other workers can avoid the hazard. Be sure you are following these safe practices, the consumable labeling and MSDS to improve the ventilation in your area. Do not continue welding until the situation has been corrected.

NOTE: The MSDS for all Lincoln consumables is available on Lincoln's website: www.lincolnelectric.com

Before we turn to the methods available to control welding fume exposure, you should understand a few basic terms:

Natural Ventilation is the movement of air through the workplace caused by natural forces. Outside, this is usually the wind. Inside, this may be the flow of air through open windows and doors.

Mechanical Ventilation is the movement of air through the workplace caused by an electrical device such as a portable fan or permanently mounted fan in the ceiling or wall.

Source Extraction (Local Exhaust) is a mechanical device used to capture welding fume at or near the arc and filter contaminants out of the air.

The ventilation or exhaust needed for your application depends upon many factors such as:

- Workspace volume
- Workspace configuration
- Number of welders
- Welding process and current
- Consumables used (mild steel, hardfacing, stainless, etc.)
- Allowable levels (TLV, PEL, etc.)
- Material welded (including paint or plating)
- Natural airflow

Your work area has adequate ventilation when there is enough ventilation and/or exhaust to control worker exposure to hazardous materials in the welding fumes and gases so the applicable limits for those materials is not exceeded. See chart of TLV and PEL for Typical Electrode Ingredients, the OSHA PEL (Permissible Exposure Limit), and the recommended guideline, the ACGIH TLV (Threshold Limit Value), for many compounds found in welding fume.

Ventilation

There are many methods which can be selected by the user to provide adequate ventilation for the specific application. The following section provides general information which may be helpful in evaluating what type of ventilation equipment may be suitable for your application. When ventilation equipment is installed, you should confirm worker exposure is controlled within applicable OSHA PEL and/or ACGIH TLV. According to OSHA regulations, when welding and cutting (mild steels), natural ventilation is usually considered sufficient to meet requirements, provided that:

1. The room or welding area contains at least 10,000 cubic feet (about 22' x 22' x 22') for each welder.
2. The ceiling height is not less than 16 feet.
3. Cross ventilation is not blocked by partitions, equipment, or other structural barriers.
4. Welding is not done in a coned space.

Spaces that do not meet these requirements should be equipped with mechanical ventilating equipment that exhausts at least 2000 CFM of air for each welder, except where local exhaust hoods or booths, or air-line respirators are used.

Important Safety Note:

When welding with electrodes which require special ventilation such as stainless or hardfacing (see instructions on container or MSDS) or on lead or cadmium plated steel and other metals or coatings which produce hazardous fumes, keep exposure as low as possible and below exposure limit values (PEL and TLV) for materials in the fume using local exhaust or mechanical ventilation. In coned spaces or in some circumstances, for example outdoors, a respirator may be required if exposure cannot be controlled to the PEL or TLV. (See MSDS and chart of TLV and PEL for Typical Electrode Ingredients.) Additional precautions are also required when welding on galvanized steel.

BIBLIOGRAPHY AND SUGGESTED READING

ANSI Z87.1, Practice for Occupational and Educational Eye and Face Protection, American National Standards Institute, 11 West 42nd Street, New York, NY 10036.

Arc Welding and Your Health: A Handbook of Health Information for Welding. Published by The American Industrial Hygiene Association, 2700 Prosperity Avenue, Suite 250, Fairfax, VA 22031-4319.

NFPA Standard 51B, Cutting and Welding Processes, National Fire Protection Association, 1 Batterymarch Park, P.O. Box 9146, Quincy, MA 02269-9959.

OSHA General Industry Standard 29 CFR 1910 Subpart Q. OSHA Hazard Communication Standard 29 CFR 1910.1200. Available from the Occupational Safety and Health Administration at <http://www.osha.org> or contact your local OSHA office.

The following publications are published by The American Welding Society, P.O. Box 351040, Miami, Florida 33135. AWS publications may be purchased from the American Welding society at <http://www.aws.org> or by contacting the AWS at 800-443-9353.

ANSI, Standard Z49.1, Safety in Welding, Cutting and Allied Processes. Z49.1 is now available for download at no charge at <http://www.lincolnelectric.com/community/safety/> or at the AWS website <http://www.aws.org>.

AWS F1.1, Method for Sampling Airborne Particulates Generated by Welding and Allied Processes.

AWS F1.2, Laboratory Method for Measuring Fume Generation Rates and Total Fume Emission of Welding and Allied Processes.

AWS F1.3, Evaluating Contaminants in the Welding Environment: A Strategic Sampling Guide.

AWS F1.5, Methods for Sampling and Analyzing Gases from Welding and Allied Processes.

AWS F3.2, Ventilation Guide for Welding Fume Control.

AWS F4.1, Recommended Safe Practices for the Preparation for Welding and Cutting of Containers and Piping That Have Held Hazardous Substances.

AWS SHF, Safety and Health Facts Sheets. Available free of charge from the AWS website at <http://www.aws.org>.

LISTED BELOW ARE SOME TYPICAL INGREDIENTS IN WELDING ELECTRODES AND THEIR TLV (ACGIH) GUIDELINES AND PEL (OSHA) EXPOSURE LIMITS

INGREDIENTS	CAS No.	TLV mg/m ³	PEL mg/m ³
Aluminum and/or aluminum alloys (as Al)*****	7429-90-5	1.0	15
Aluminum oxide and/or Bauxite*****	1344-28-1	1.0	5**
Barium compounds (as Ba)*****	513-77-9	0.5	0.5
Chromium and chromium alloys or compounds (as Cr)*****	7440-47-3	0.5(b)	0.5(b)
Hexavalent Chromium (Cr VI)	18540-29-9	0.05(b)	.005(b)
Copper Fume	7440-50-8	0.2	0.1
Cobalt Compounds	7440-48-4	0.02	0.1
Fluorides (as F)	7789-75-5	2.5	2.5
Iron	7439-89-6	10*	10*
Limestone and/or calcium carbonate	1317-65-3	10*	15
Lithium compounds (as Li)	554-13-2	15	10*
Magnesite	1309-48-4	10	15
Magnesium and/or magnesium alloys and compounds (as Mg)	7439-95-4	10*	10*
Manganese and/or manganese alloys and compounds (as Mn)*****	7439-96-5	0.02	5.0(c)
Mineral silicates	1332-58-7	5**	5**
Molybdenum alloys (as Mo)	7439-98-7	10	10
Nickel*****	7440-02-0	0.1	1
Silicates and other binders	1344-09-8	10*	10*
Silicon and/or silicon alloys and compounds (as Si)	7440-21-3	10*	10*
Strontium compounds (as Sr)	1633-05-2	10*	10*
Zirconium alloys and compounds (as Zr)	12004-83-0	5	5

Supplemental Information:

(*) Not listed. Nuisance value maximum is 10 milligrams per cubic meter. PEL value for iron oxide is 10 milligrams per cubic meter. TLV value for iron oxide is 5 milligrams per cubic meter.

(**) As respirable dust.

(****) Subject to the reporting requirements of Sections 311, 312, and 313 of the Emergency Planning and Community Right-to-Know Act of 1986 and of 40CFR 370 and 372.

(b) The PEL for chromium (VI) is .005 milligrams per cubic meter as an 8 hour time weighted average. The TLV for water-soluble chromium (VI) is 0.05 milligrams per cubic meter. The TLV for insoluble chromium (VI) is 0.01 milligrams per cubic meter.

c) Values are for manganese fume. STEL (Short Term Exposure Limit) is 3.0 milligrams per cubic meter. OSHA PEL is a ceiling value.

(****) There is no listed value for insoluble barium compounds. The TLV for soluble barium compounds is 0.5 mg/m³.

TLV and PEL values are as of April 2006. Always check Material Safety Data Sheet (MSDS) with product or on the Lincoln Electric website at <http://www.lincolnelectric.com>

MASTER TABLE OF CONTENTS FOR ALL SECTIONS

	Page
Safety	ii-viii
<hr/>	
Installation, Operation, Accessories, Maintenance	See IM10121
Theory of Operation	Section E
Troubleshooting and Repair	Section F
Electrical Diagrams	Section G

TABLE OF CONTENTS - THEORY OF OPERATION SECTION -

Theory Of Operation Section E

Input Power And Motor Protection Switch. E-2

Transformer, Contactor And Optional Auto Start / Stop Arc Sensor. E-3

Motor E-4

Control Board, Cleaning System And Fan Switch E-5

Figure E.1 - Block logic diagram

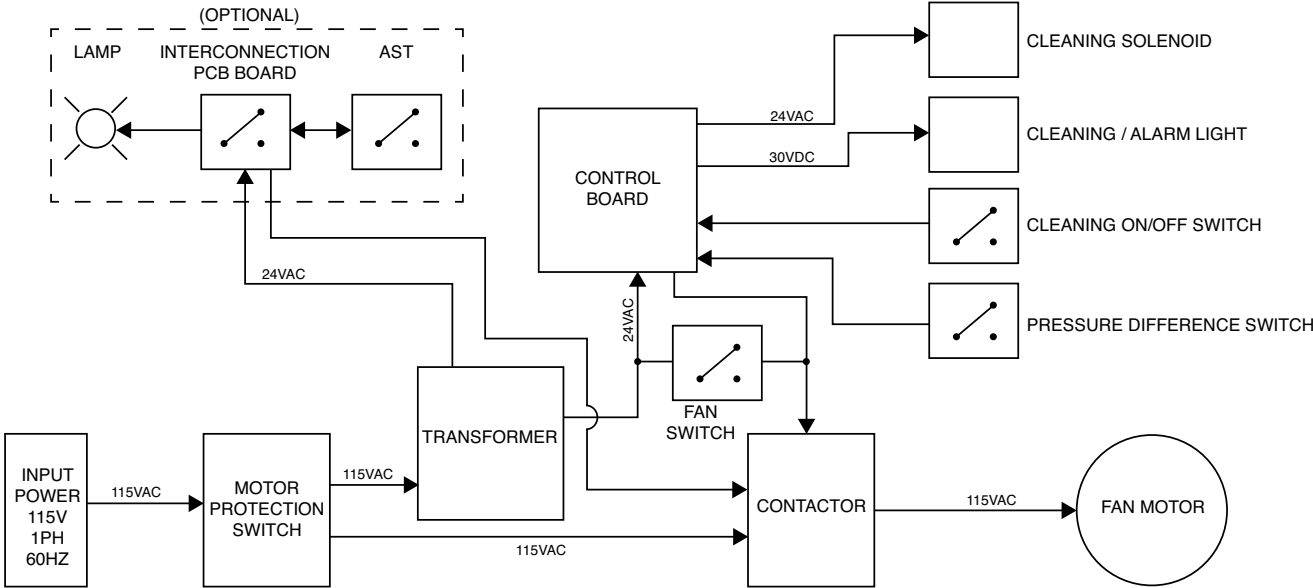
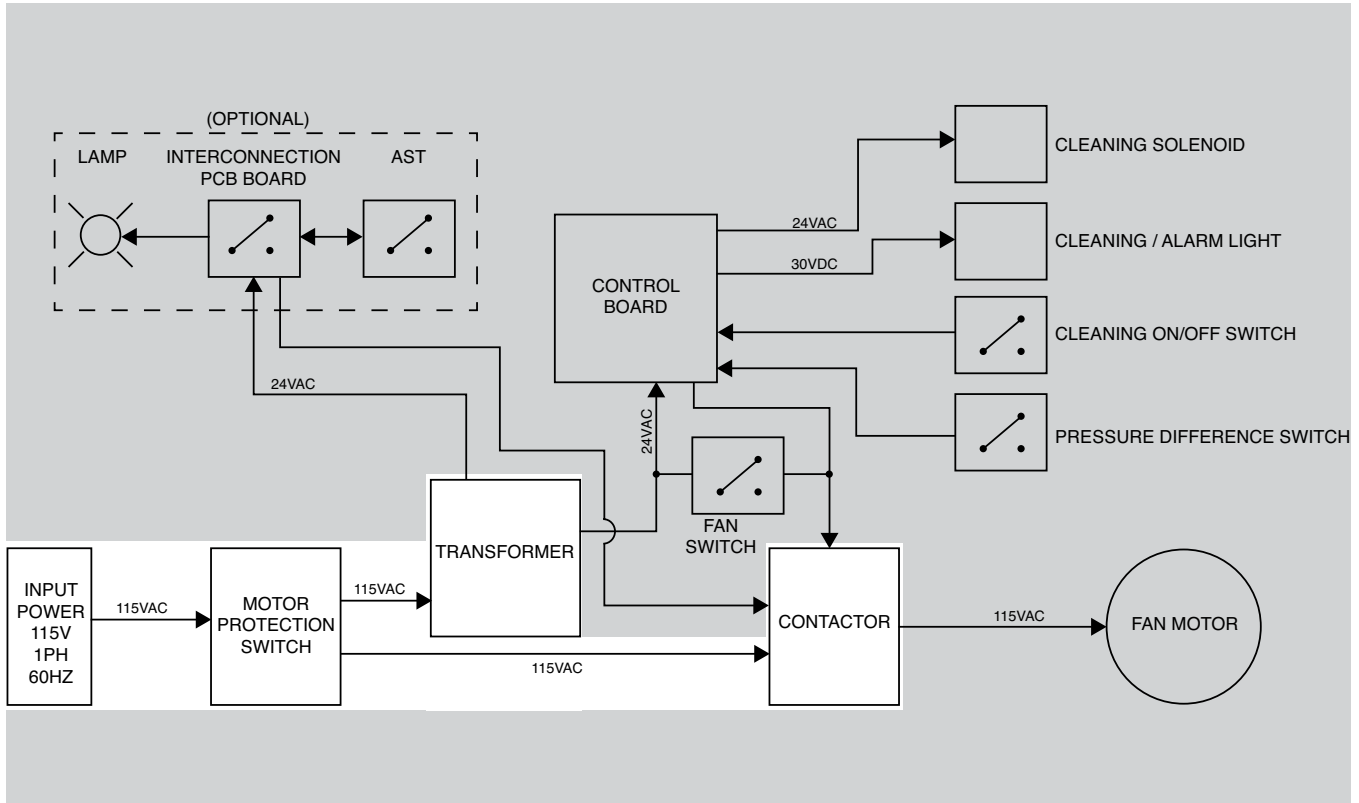

Figure E.2 - Input power and motor protection switch



INPUT POWER AND MOTOR PROTECTION SWITCH

The Mobiflex 400-MS(/HE) operates on 115VAC/60Hz., single phase power. This input power is applied to the motor protection switch (On/Off switch). When the motor protection switch is open (OFF position), no current will flow and the Mobiflex 400-MS(/HE) will shut down. When the motor protection switch is closed (ON position), input power will be sent through an internal thermal overload relay and then to the transformer and the contactor. The internal thermal overload relay (part of the motor protection switch) is set at the factory to open at 12 amps.

NOTE:

Unshaded areas of Block Logic Diagram are the subject of discussion.

Figure E.3 - Transformer, contactor and optional auto start / stop arc sensor

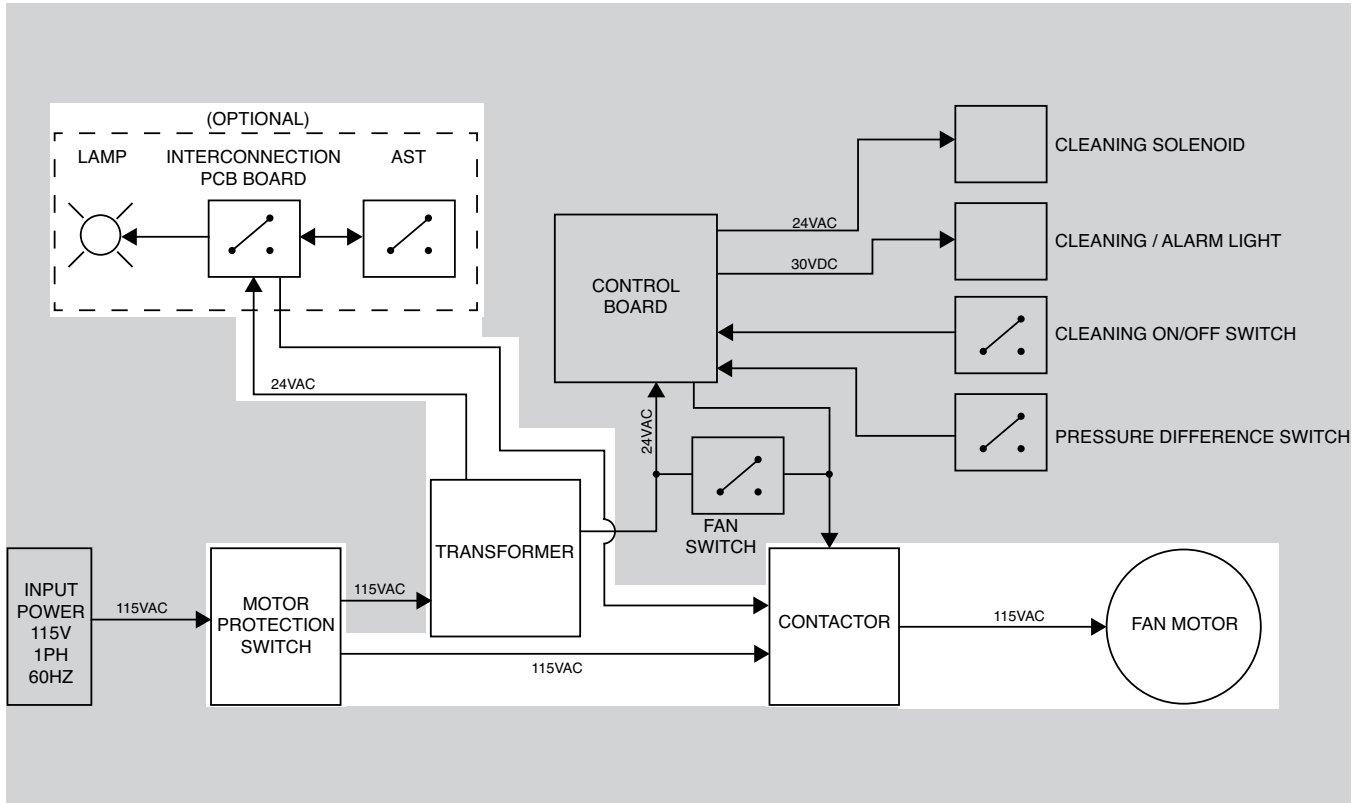

TRANSFORMER, CONTACTOR AND OPTIONAL AUTO START/STOP ARC SENSOR

The transformer receives 115VAC input voltage from the motor protection switch. 115VAC is applied to the primary windings of the transformer. The 115VAC primary voltage is stepped down to 24VAC. The 24VAC secondary voltage is applied to the contactor. This 24VAC energizes the contactor causing the contacts to close and send the 115VAC to the fan motor.

When the optional lamp kit and auto start/stop arc sensor are used, the 24VAC is supplied to the optional remote switch, lamp and auto start/stop arc sensor. When the auto start/stop arc sensor activates (welding current is detected) or the remote switch is turned on, 24VAC is sent to the contactor. This 24VAC energizes the contactor causing the contacts to close and send the input voltage to the motor.

NOTE:

Unshaded areas of Block Logic Diagram are the subject of discussion.

Figure E.4 - Motor

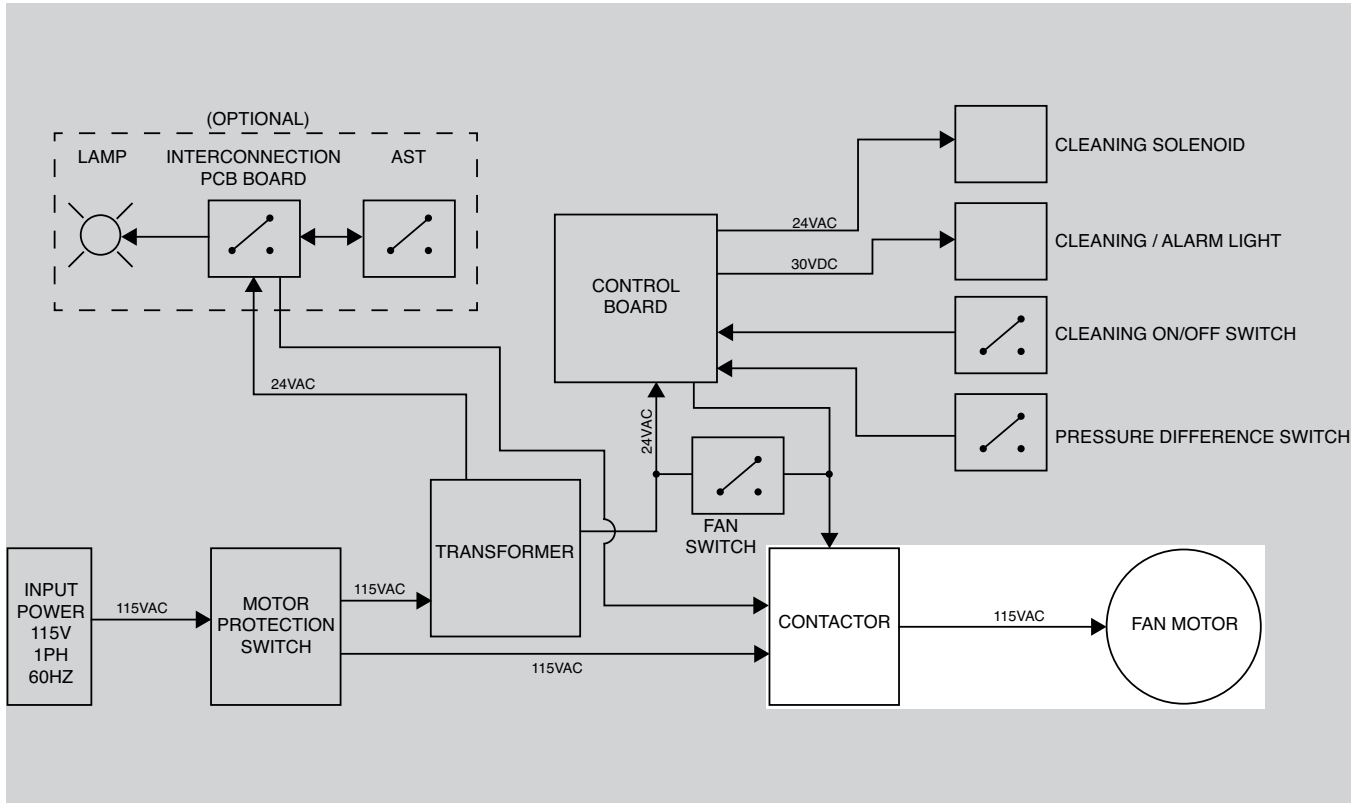

MOTOR

The single phase 3300 RPM motor is powered by 115VAC. When activated by the contactor this motor turns the blower paddles to create the 735 CFM (cubic feet per minute) air flow.

NOTE:

Unshaded areas of Block Logic Diagram are the subject of discussion.

Figure E.5 - Control board, cleaning system and fan switch

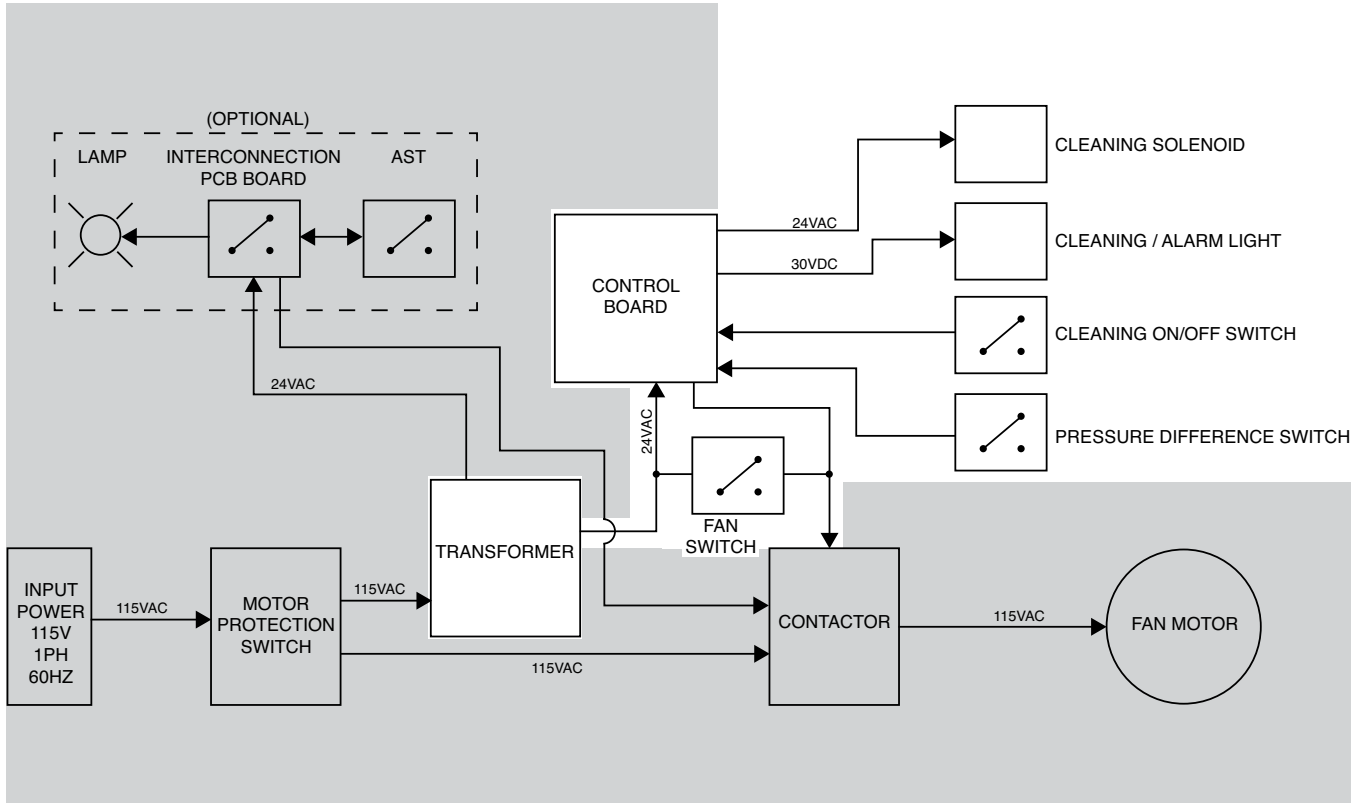

CONTROL BOARD, CLEANING SYSTEM AND FAN SWITCH

The control board receives 24VAC from the transformer. The control board distributes power to the cleaning solenoid and the cleaning/ alarm light. The control board activates the cleaning system via the cleaning ON/OFF switch and the pressure difference switch.

When the cleaning ON/OFF switch is activated (closed) the control board sends 30VDC to illuminate the cleaning/ alarm light and activates the cleaning solenoid.

The pressure difference switch monitors the static air pressure as it enters and exits the filter cartridge. If the air pressure entering the filter unit is greater than the air pressure exiting the filter unit, the pressure difference switch sends a signal to the control board to activate the cleaning solenoid.

The fan switch receives 24VAC from the transformer. When the fan switch activates (closes) the 24VAC energizes the contactor causing the contacts to close and send the input current to the motor.

NOTE:

Unshaded areas of Block Logic Diagram are the subject of discussion.

**TABLE OF CONTENTS
- TROUBLESHOOTING AND REPAIR SECTION -**

Troubleshooting and Repair..... Section F

How to Use Troubleshooting Guide..... F-2

PC Board Troubleshooting Procedures F-3

Troubleshooting Guide F-4/F-7

Case Cover Removal And Replacement Procedure F-9

Contactors Test F-15

Transformer Test..... F-19

Motor Protection Switch Test..... F-23

Motor Test F-27

Motor Capacitor Test F-29

Control PC Board And Cleaning Solenoid Test..... F-33

Extraction Arm Removal And Replacement Procedure..... F-37

Front Wheel Removal And Replacement Procedure F-41

Terminal Block Removal And Replacement Procedure..... F-45

Contactors Removal And Replacement Procedure..... F-49

Transformer Removal And Replacement Procedure F-53

Motor Protection Switch Removal And Replacement Procedure F-57

Motor And Fan Removal And Replacement Procedure..... F-61

Motor Capacitor Removal And Replacement Procedure..... F-67

Control PC Board Removal And Replacement Procedure F-71

Cleaning Solenoid Removal And Replacement Procedure F-75

HOW TO USE TROUBLESHOOTING GUIDE

WARNING

Service and repair should be performed by only Lincoln Electric Factory Trained Personnel. Unauthorized repairs performed on this equipment may result in danger to the technician and machine operator and will invalidate your factory warranty. For your safety and to avoid Electrical Shock, please observe all safety notes and precautions detailed throughout this manual.

This Troubleshooting Guide is provided to help you locate and repair possible machine malfunctions. Simply follow the three-step procedure listed below.

Step 1. LOCATE PROBLEM (SYMPTOM). Look under the column labeled “PROBLEM” (SYMPTOMS). This column describes possible symptoms that the machine may exhibit. Find the listing that best describes the symptom that the machine is exhibiting.

Step 2. PERFORM EXTERNAL TESTS. The second column, labeled “POSSIBLE AREAS OF MISADJUSTMENT(S)”, lists the obvious external possibilities that may contribute to the machine symptom. Perform these tests/checks in the order listed. In general, these tests can be conducted without removing the case cover.

Step 3. PERFORM COMPONENT TESTS. The last column, labeled “Recommended Course of Action” lists the most likely components that may have failed in your machine. It also specifies the appropriate test procedure to verify that the subject component is either good or bad. If there are a number of possible components, check the components in the order listed to eliminate one possibility at a time until you locate the cause of your problem.

All of the referenced test procedures referred to in the Troubleshooting Guide are described in detail at the end of this section. Refer to the Troubleshooting and Repair Table of Contents to locate each specific Test Procedure. All of the referred to test points, components, terminal strips, etc., can be found on the referenced electrical wiring diagrams and schematics. Refer to the Electrical Diagrams Section Table of Contents to locate the appropriate diagram.

CAUTION

If for any reason you do not understand the test procedures or are unable to perform the test/repairs safely, contact the Lincoln Electric Automation Department for electrical troubleshooting assistance before you proceed. Call 1-888-935-3878.

PC BOARD TROUBLESHOOTING PROCEDURES

WARNING

ELECTRIC SHOCK can kill.

- Have an electrician install and service this equipment. Turn the input power OFF at the fuse box before working on equipment. Do not touch electrically hot parts.



CAUTION

Sometimes machine failures appear to be due to PC board failures. These problems can sometimes be traced to poor electrical connections. To avoid problems when troubleshooting and replacing PC boards, please use the following procedure:

1. Determine to the best of your technical ability that the PC board is the most likely component causing the failure symptom.
2. Check for loose connections at the PC board to assure that the PC board is properly connected.
3. If the problem persists, replace the suspect PC board using standard practices to avoid static electrical damage and electrical shock. Read the warning inside the static resistant bag and perform the following procedures:

PC board can be damaged by static electricity.

- Remove your body's static charge before opening the static-shielding bag. Wear an anti-static wrist strap. For safety, use a 1 Meg ohm resistive cord connected to a grounded part of the equipment frame.
- If you don't have a wrist strap, touch an un-painted, grounded, part of the equipment frame. Keep touching the frame to prevent static build-up. Be sure not to touch any electrically live parts at the same time.



- Tools which come in contact with the PC board must be either conductive, anti-static or static-dissipative.
- Remove the PC board from the static-shielding bag and place it directly into the equipment. Don't set the PC board on or near paper, plastic or cloth which could have a static charge. If the PC board can't be installed immediately, put it back in the static-shielding bag.
- If the PC board uses protective shorting jumpers, don't remove them until installation is complete.
- If you return a PC board to The Lincoln Electric Company for credit, it must be in the static-shielding bag. This will prevent further damage and allow proper failure analysis.

4. Test the machine to determine if the failure symptom has been corrected by the replacement PC board.

NOTE: It is desirable to have a spare (known good) PC board available for PC board troubleshooting.

NOTE: Allow the machine to heat up so that all electrical components can reach their operating temperature.

5. Remove the replacement PC board and substitute it with the original PC board to recreate the original problem.
 - a. If the original problem does not reappear by substituting the original board, then the PC board was not the problem. Continue to look for bad connections in the control wiring harness, junction blocks and terminal strips.
 - b. If the original problem is recreated by the substitution of the original board, then the PC board was the problem. Reinstall the replacement PC board and test the machine.

6. Always indicate that this procedure was followed when warranty reports are to be submitted.

NOTE: Following this procedure and writing on the warranty report, "INSTALLED AND SWITCHED PC BOARDS TO VERIFY PROBLEM," will help avoid denial of legitimate PC board warranty claims.

Observe Safety Guidelines detailed in the beginning of this manual.

TROUBLESHOOTING GUIDE

PROBLEMS (SYMPTOMS)	POSSIBLE AREAS OF MISADJUSTMENT(S)	RECOMMENDED COURSE OF ACTION
MOBIFLEX 400-MS(/HE) BASE UNIT		
Motor does not start. Machine does not function.	<ol style="list-style-type: none"> 1. No input power. 2. Missing jumper on input connection. 3. Input power cord may be defective. 4. Motor protection switch may be defective. 5. Wire in base swivel mount missing. 	<ol style="list-style-type: none"> 1. Check for loose or faulty connections. See Wiring Diagram. 2. Perform the Contactors Test. 3. Perform the Motor Protection Switch Test.
Motor makes a humming sound. Machine does not function.	<ol style="list-style-type: none"> 1. Motor capacitor defective / not connected. 	<ol style="list-style-type: none"> 1. Perform the Motor Capacitor Test.
Motor stops automatically. Machine does not function.	<ol style="list-style-type: none"> 1. Motor protection switch may be activated. 	<ol style="list-style-type: none"> 1. Check overload current setting of 12A. 2. Perform the Motor Test.
Control light extinguished during cleaning process. No indication.	<ol style="list-style-type: none"> 1. Control light may be defective. 	<ol style="list-style-type: none"> 1. Perform the Control PC Board And Cleaning Solenoid Test.
Control light keeps blinking ("Alarm"). Insufficient airflow.	<ol style="list-style-type: none"> 1. Saturated LongLife filter. 2. Perform off-line filter cleaning cycle. See Off-line Cleaning in the Operators Manual. 3. Replace the LongLife filter. See LongLife Filter Cartridge in the Operators Manual. 	<ol style="list-style-type: none"> 1. N/A.
Control light keeps blinking ("Alarm"). No automatic filter cleaning.	<ol style="list-style-type: none"> 1. Filter cleaning mechanism may be defective or worn. 2. 24VAC magnetic valve may be defective. 3. No compressed air or compressed air pressure too low. Check the compressed air system and/or compressed air connection. 4. Pressure difference switch may be defective. 	<ol style="list-style-type: none"> 1. Perform the Control PC Board And Cleaning Solenoid Test.



If for any reason you do not understand the test procedures or are unable to perform the test/repairs safely, contact the Lincoln Electric Automation Department for electrical troubleshooting assistance before you proceed. Call 1-888-935-3878.

Observe Safety Guidelines detailed in the beginning of this manual.

TROUBLESHOOTING GUIDE

PROBLEMS (SYMPTOMS)	POSSIBLE AREAS OF MISADJUSTMENT(S)	RECOMMENDED COURSE OF ACTION
MOBIFLEX 400-MS(/HE) BASE UNIT		
<p>Machine does not react to pressing filter 'Cleaning ON/OFF - RESET' button. Activating off-line cleaning and reset not possible.</p>	<ol style="list-style-type: none"> 1. The filter 'Cleaning ON/OFF - RESET' button may be defective. 	<ol style="list-style-type: none"> 1. Check the filter 'Cleaning ON/OFF - RESET' button. 2. Perform the Control PC Board And Cleaning Solenoid Test. 3. Perform the Transformer Test.
<p>Poor suction. Machine does not function properly.</p>	<ol style="list-style-type: none"> 1. LongLife filter cartridge may be clogged. 2. Perform off-line filter cleaning cycle. See Off-line Cleaning in the Operators Manual. 3. Replace the LongLife filter. See LongLife Filter Cartridge in the Operators Cartridge. 4. Clean (see Periodic Maintenance in the Operators Manual) or replace (See Prefilter in the Operators Manual) the prefilter. 5. Check or replace the sealing material. 6. Remove obstructions from the outlet grid. 7. Clean the extraction fan. 	<ol style="list-style-type: none"> 1. Perform the Motor Test.
<p>Dust or smoke coming out of the filter cover. Pollution of the facility.</p>	<ol style="list-style-type: none"> 1. Replace the LongLife filter. See LongLife Filter Cartridge in the Operator Manual. 2. Position the LongLife filter cartridge correctly. 	<ol style="list-style-type: none"> 1. N/A.
<p>Dust or smoke coming out of the dust tray. Pollution of the facility.</p>	<ol style="list-style-type: none"> 1. Position the dust tray correctly. 2. Replace the sealing material. 	<ol style="list-style-type: none"> 1. N/A.
<p>Vibrations in the machine. Machine not steady.</p>	<ol style="list-style-type: none"> 1. Imbalance in extraction fan. 	<ol style="list-style-type: none"> 1. Clean the extraction fan.



If for any reason you do not understand the test procedures or are unable to perform the test/repairs safely, contact the Lincoln Electric Automation Department for electrical troubleshooting assistance before you proceed. Call 1-888-935-3878.

Observe Safety Guidelines detailed in the beginning of this manual.

TROUBLESHOOTING GUIDE

PROBLEMS (SYMPTOMS)	POSSIBLE AREAS OF MISADJUSTMENT(S)	RECOMMENDED COURSE OF ACTION
MOBIFLEX 400-MS(/HE) BASE UNIT & LFA 3.1 / 4.1 (K2633-2, -4) AUTOMATIC ONLY		
<p>Motor does not start automatically. Machine does not function.</p>	<ol style="list-style-type: none"> 1. Lens cap of arc sensor damaged or dirty. 2. Arc sensor may be defective. 	<ol style="list-style-type: none"> 1. Replace or clean plastic lens cap of arc sensor. 2. Replace the arc sensor.



If for any reason you do not understand the test procedures or are unable to perform the test/repairs safely, contact the Lincoln Electric Automation Department for electrical troubleshooting assistance before you proceed. Call 1-888-935-3878.

Observe Safety Guidelines
detailed in the beginning of this manual.

TROUBLESHOOTING GUIDE

PROBLEMS (SYMPTOMS)	POSSIBLE AREAS OF MISADJUSTMENT(S)	RECOMMENDED COURSE OF ACTION
LFA 3.1 / 4.1 MANUAL / AUTOMATIC		
Extraction hood not in balance. Extraction hood does not stay in desired position.	1. Not enough friction.	1. Adjust balance. See Balance Check in <i>Operator Manual</i> .
Extraction hood not in balance. Extraction hood can't be moved in desired position.	1. Too much friction.	1. Adjust friction. See Balance Check in <i>Operator Manual</i> .
Extraction capacity insufficient. Pollution of the facility.	1. Throttle valve closed. 2. Flexible hose(s) torn or loose. 3. Rubber seal(s) torn.	1. Open throttle valve. 2. Replace flexible hose(s) or apply correctly. 3. Replace rubber seal(s).
Extraction arm not in balance. Entire arm falls on its own.	1. Lack of spring tension fan side.	1. Increase spring tension. See Balance Check in <i>Operator Manual</i> .
Extraction arm not in balance. Hood section falls on its own.	1. Lack of spring tension hood side.	1. Increase spring tension. See Balance Check in <i>Operator Manual</i> .
Extraction arm creaks or squeaks. Excessive wear of parts.	1. Insufficient lubrication in hinges. 2. Worn out steel cable. 3. Worn out bearing of balance wheel.	1. Lubricate hinges using oil or grease. See Maintenance Section in <i>Operator Manual</i> . 2. Replace steel cable and lubricate. 3. Replace bearing and lubricate.
LFA 3.1 / 4.1 (K2633-2, -4) AUTOMATIC ONLY		
Insufficient light to the workpiece. No clear view.	1. Weld spatters on glass spatter guard. 2. Halogen lamp may be defective.	1. Replace glass spatted guard. 2. Replace halogen lamp.



CAUTION

If for any reason you do not understand the test procedures or are unable to perform the test/repairs safely, contact the Lincoln Electric Automation Department for electrical troubleshooting assistance before you proceed. Call 1-888-935-3878.

CASE COVER REMOVAL AND REPLACEMENT PROCEDURE

WARNING

Service and repair should be performed only by Lincoln Electric factory trained personnel. Unauthorized repairs performed on this equipment may result in danger to the technician or machine operator and will invalidate your factory warranty. For your safety and to avoid electrical shock, please observe all safety notes and precautions detailed throughout this manual.

If for any reason you do not understand the test procedures or are unable to perform the test/repairs safely, contact the Lincoln Electric Automation Department for electrical troubleshooting assistance before you proceed. Call 1-888-935-3878.

TEST DESCRIPTION

This procedure will aid the technician in the removal and replacement of the Case Covers.

MATERIALS NEEDED

- 10mm Nutdriver
- Needle Nose Pliers
- Phillips Screwdriver
- Wiring Diagram

CASE COVER REMOVAL AND REPLACEMENT PROCEDURE *(continued)*

Figure F.1 – Compressed air connection point

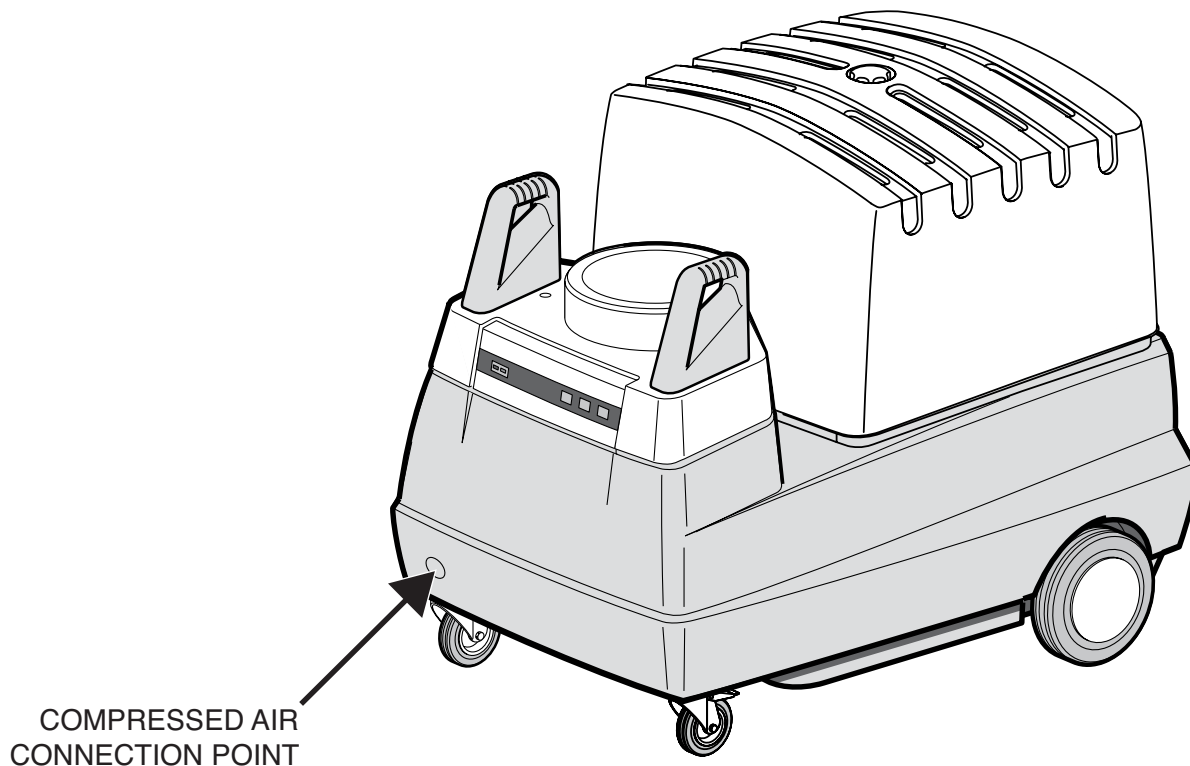

REMOVAL PROCEDURE

1. Remove the input power to the Mobiflex 400-MS(/HE).
2. Disconnect compressed air from the Mobiflex 400-MS(/HE), if necessary. The compressed air connection point is located on the front of the machine next to the input power cord. See **Figure F.1**.
3. Secure the Mobiflex 400-MS(/HE) in place by pressing down on the large front tab on the right (when facing the machine) front wheel. This will lock the wheel in place and keep the machine from moving while performing tests and procedures.
4. Perform the **Extraction Arm Removal Procedure**, if necessary.
5. Using a 10mm nutdriver, remove the four screws securing the control housing to the machine. See **Figure F.2**.
6. Using needle nose pliers, disconnect the ground strap from the control panel cover. See **Figure F.3**. See Wiring Diagram.
7. Using a Phillips screwdriver, remove the four screws securing the control panel cover to the machine. See **Figure F.4**. Do not fully remove the control panel cover at this time as there are several leads attached to the rear of the control panel cover.
8. Carefully tilt the control panel cover forward to gain access to the lead connections at the rear of the control panel cover.
9. Label and disconnect the two leads from the rear of the 'Cleaning ON/OFF' switch. See **Figure F.5**. See Wiring Diagram.
10. Label and disconnect the two leads from the rear of the 'Cleaning/ Alarm' light. See **Figure F.5**. See Wiring Diagram.
11. Label and disconnect the two leads from the rear of the 'Fan ON/OFF' switch. See **Figure F.5**. See Wiring Diagram.
12. Label and disconnect the two ground leads from the rear of the control panel cover. See Wiring Diagram.
13. The control panel can now be moved to gain access to the internal components of the machine.

CASE COVER REMOVAL AND REPLACEMENT PROCEDURE *(continued)*

Figure F.2 – Control housing removal

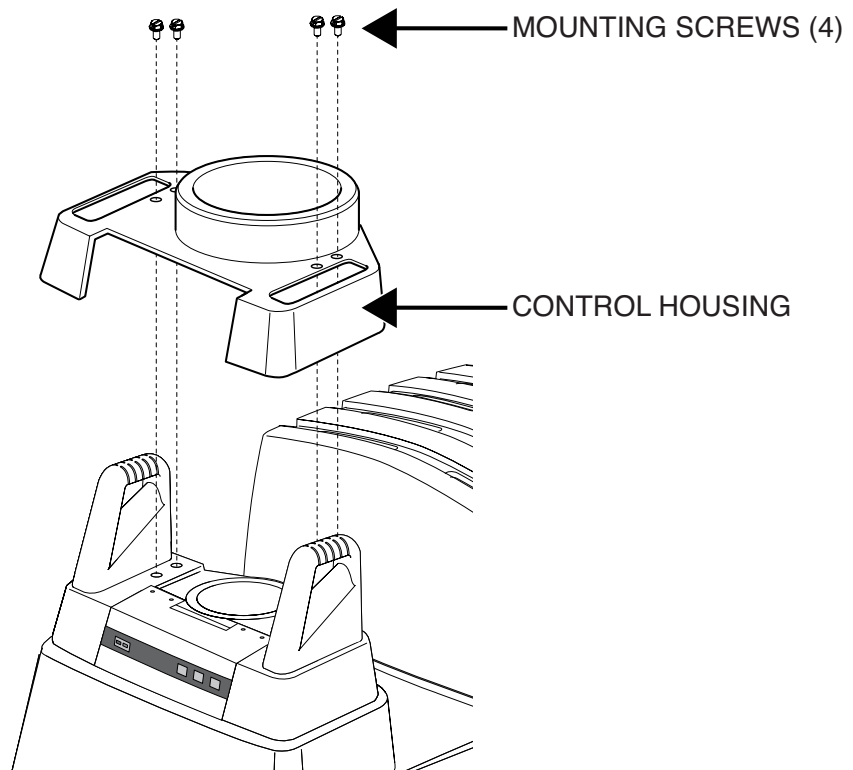
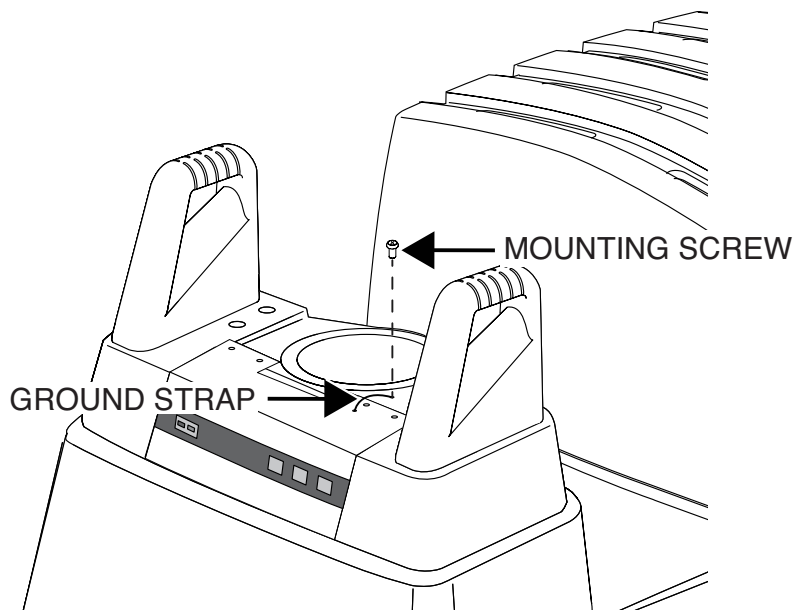

Figure F.3 – Ground strap disconnection



CASE COVER REMOVAL AND REPLACEMENT PROCEDURE *(continued)*

Figure F.4 – Control panel cover mounting screw locations

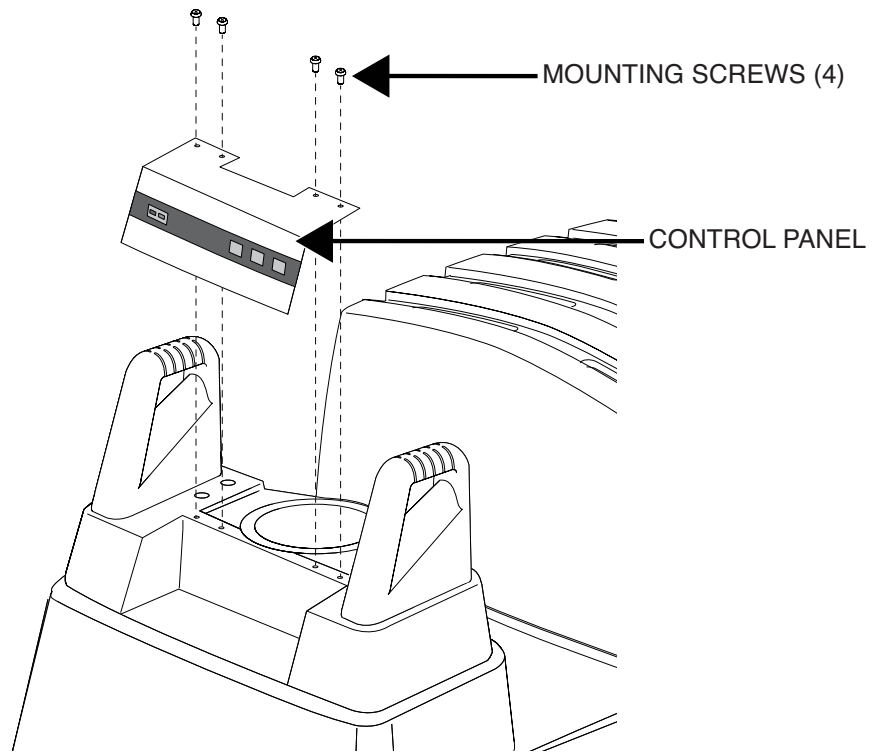
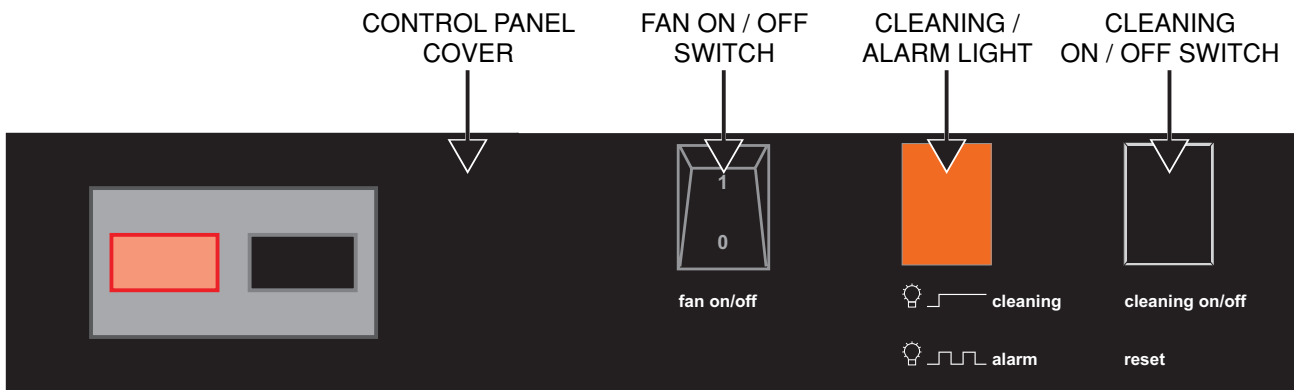

Figure F.5 – Control panel cover components



CASE COVER REMOVAL AND REPLACEMENT PROCEDURE *(continued)*

REPLACEMENT PROCEDURE

1. Carefully position the control panel cover onto the machine.
2. Carefully tilt the control panel cover forward to gain access to the lead connections at the rear of the control panel cover.
3. Connect the two ground leads to the rear of the control panel cover. See Wiring Diagram.
4. Connect the two leads to the rear of the 'Fan ON/OFF' switch. See Wiring Diagram.
5. Connect the two leads to the rear of the 'Cleaning/Alarm' light. See Wiring Diagram.
6. Connect the two leads to the rear of the 'Cleaning ON/OFF' switch. See Wiring Diagram.
7. Using a Phillips screwdriver, attach the four screws securing the control panel cover to the machine.
8. Using needle nose pliers, connect the ground strap to the control panel cover. See Wiring Diagram.
9. Carefully position the control housing onto the machine.
10. Using a 10mm nutdriver, attach the four screws securing the control housing to the machine.
11. Perform the ***Extraction Arm Replacement Procedure***, if necessary.
12. Connect compressed air to the Mobiflex 400-MS(/HE), if necessary. The compressed air connection point is located on the front of the machine next to the input power cord.

CONTACTOR TEST

WARNING

Service and repair should be performed only by Lincoln Electric factory trained personnel. Unauthorized repairs performed on this equipment may result in danger to the technician or machine operator and will invalidate your factory warranty. For your safety and to avoid electrical shock, please observe all safety notes and precautions detailed throughout this manual.

If for any reason you do not understand the test procedures or are unable to perform the test/repairs safely, contact the Lincoln Electric Automation Department for electrical troubleshooting assistance before you proceed. Call 1-888-935-3878.

TEST DESCRIPTION

This procedure will help determine if the Contactor is functioning properly.

MATERIALS NEEDED

- Slotted Screwdriver
- Volt/Ohmmeter
- 24VAC Power Supply
- Wiring Diagram

CONTACTOR TEST *(continued)*

Figure F.6 – Contactor location

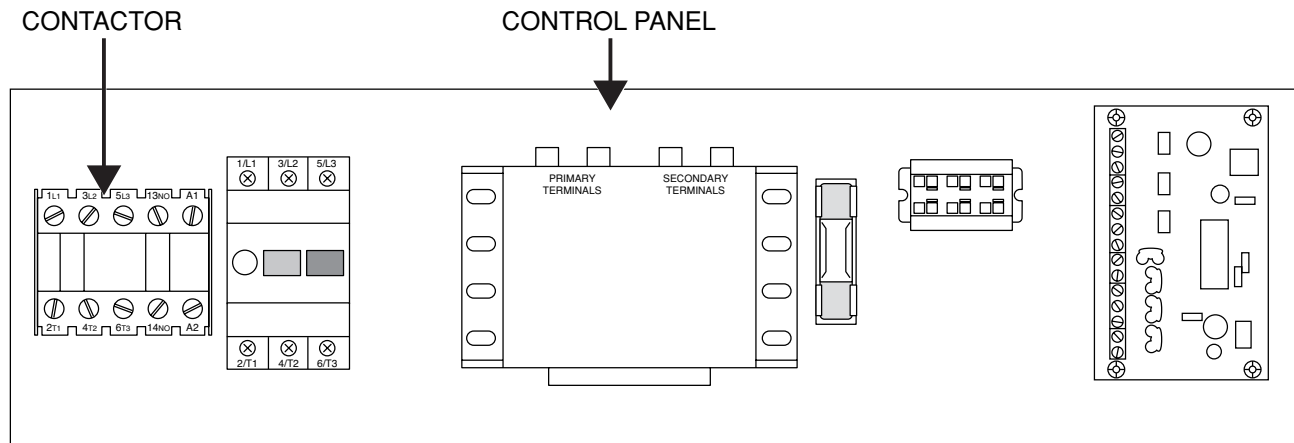

PROCEDURE

1. Remove the input power to the Mobiflex 400-MS/(HE).
2. Perform the **Case Cover Removal Procedure**.
3. Locate the contactor on the control panel. See Figure F.6.
4. Using a slotted screwdriver, label and disconnect the leads from terminals A1 and A2 of the contactor. See **Figure F.7**. See Wiring Diagram.
5. Using a volt/ohmmeter, check the resistance between terminals 3L2 and 4T2. Resistance should be infinite. If not the contactors may be stuck closed. See **Figure F.7**. See Wiring Diagram.
6. Using a volt/ohmmeter, check the resistance between terminals 5L3 and 6T3. Resistance should be infinite. If not the contactors may be stuck closed. See **Figure F.7**. See Wiring Diagram.
7. Using a 24VAC power supply, carefully apply 24VAC to terminals A1 and A2 of the contactor. This should activate the contactor. See **Figure F.7**. See Wiring Diagram.
8. Using a volt/ohmmeter, check resistance between terminals 3L2 and 4T2. The contactor should activate (close) and provide zero resistance. See **Figure F.7**. See Wiring Diagram.
9. Using a volt/ohmmeter, check resistance between terminals 5L3 and 6T3. The contactor should activate (close) and provide zero resistance. See **Figure F.7**. See Wiring Diagram.
10. If any of these tests fail, perform the **Contactor Removal And Replacement Procedure**.
11. Using a slotted screwdriver, connect the leads to terminals A1 and A2 of the contactor. See Wiring Diagram.
12. Perform the **Case Cover Replacement Procedure**.

CONTACTOR TEST *(continued)*

Figure F.7 – Contactor lead locations

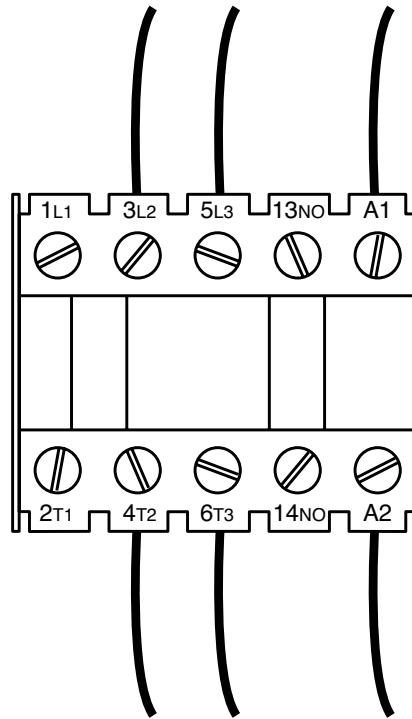

TRANSFORMER TEST

WARNING

Service and repair should be performed only by Lincoln Electric factory trained personnel. Unauthorized repairs performed on this equipment may result in danger to the technician or machine operator and will invalidate your factory warranty. For your safety and to avoid electrical shock, please observe all safety notes and precautions detailed throughout this manual.

If for any reason you do not understand the test procedures or are unable to perform the test/repairs safely, contact the Lincoln Electric Automation Department for electrical troubleshooting assistance before you proceed. Call 1-888-935-3878.

TEST DESCRIPTION

This test will help determine if the Transformer is functioning properly.

MATERIALS NEEDED

Volt/Ohmmeter
115VAC Power Supply
Wiring Diagram

TRANSFORMER TEST *(continued)*

Figure F.8 – Transformer location

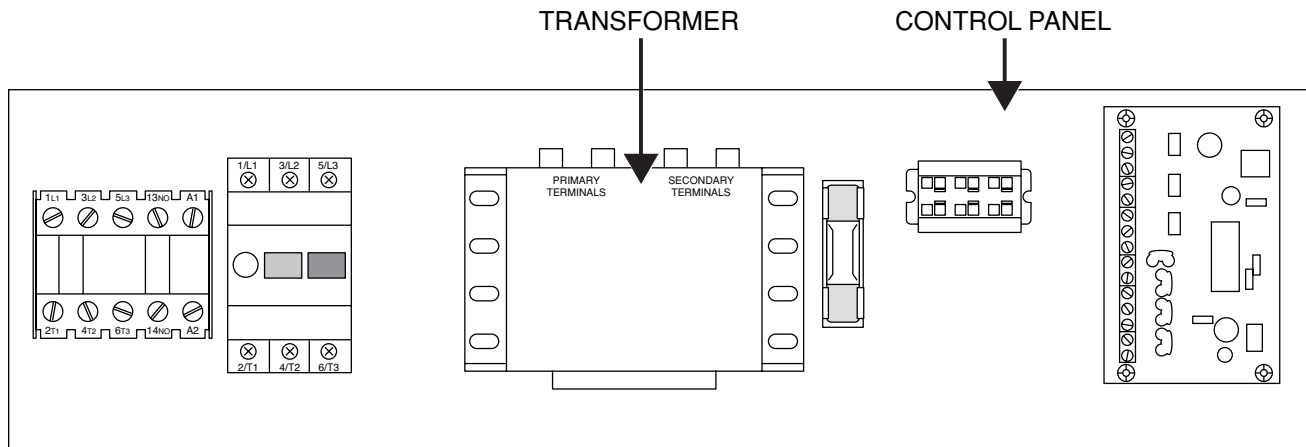

PROCEDURE

1. Remove the input power to the Mobiflex 400-MS(/HE).
2. Perform the **Case Cover Removal Procedure**.
3. Locate the transformer on the control panel. See Figure F.8.
4. Label and disconnect all four leads from the transformer. See **Figure F.9**. See Wiring Diagram.
5. Using a volt/ohmmeter, check the resistance of the 24 volt secondary winding of the transformer. Normal resistance is approximately 0.7 ohms. See **Figure F.10**. See Wiring Diagram.
6. Using a volt/ohmmeter, check the resistance of the 115V primary winding of the control transformer. Normal resistance is approximately 13 - 14 ohms. See **Figure F.10**. See Wiring Diagram.
7. Using a volt/ohmmeter, check the resistance between the primary and secondary windings. Normal resistance should be at least 500,000 ohms. See **Figure F.10**. See Wiring Diagram.
8. Using a volt/ohmmeter, check the resistance from the primary and secondary windings to ground. Normal resistance should be at least 500,000 ohms to ground. See **Figure F.10**. See Wiring Diagram.
9. Using a 115VAC power supply, carefully apply 115VAC to the correct primary terminals of the transformer. See **Figure F.10**. See Wiring Diagram.
10. Using a volt/ohmmeter, verify that 24VAC is being generated at the secondary terminals of the transformer. See **Figure F.10**. See Wiring Diagram.
11. If any of these tests fail, perform the **Transformer Removal And Replacement Procedure**.
12. Connect all four previously removed leads to the transformer terminals. See Wiring Diagram.
13. Perform the **Case Cover Replacement Procedure**.

TRANSFORMER TEST *(continued)*

Figure F.9 – Transformer lead locations

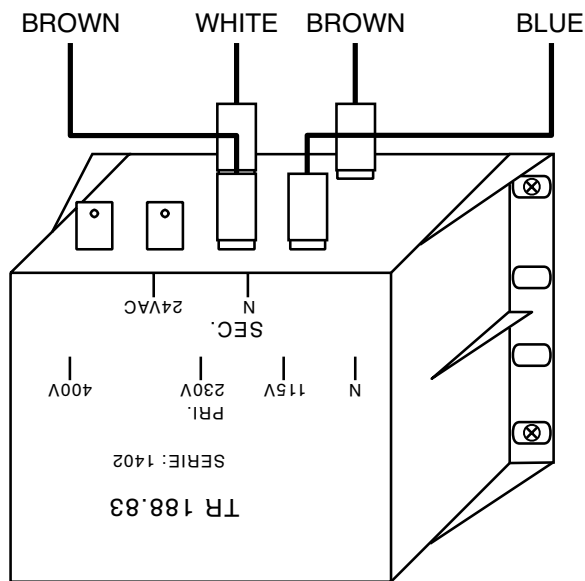
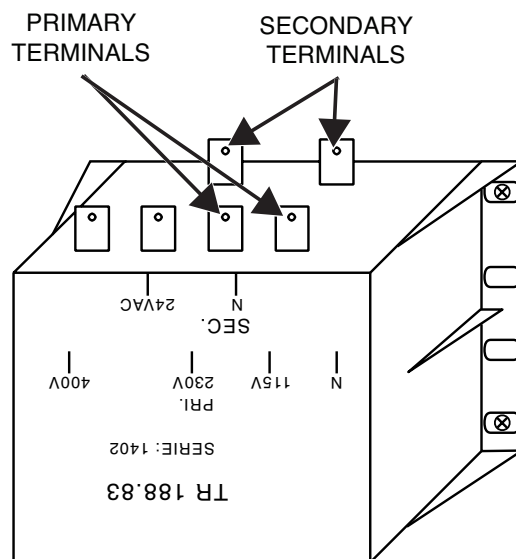

Figure F.10 – Transformer terminals



MOTOR PROTECTION SWITCH TEST

WARNING

Service and repair should be performed only by Lincoln Electric factory trained personnel. Unauthorized repairs performed on this equipment may result in danger to the technician or machine operator and will invalidate your factory warranty. For your safety and to avoid electrical shock, please observe all safety notes and precautions detailed throughout this manual.

If for any reason you do not understand the test procedures or are unable to perform the test/repairs safely, contact the Lincoln Electric Automation Department for electrical troubleshooting assistance before you proceed. Call 1-888-935-3878.

TEST DESCRIPTION

This test will help determine if the Motor Protection Switch is functioning properly.

MATERIALS NEEDED

Volt/Ohmmeter
Phillips Screwdriver
Wiring Diagram

MOTOR PROTECTION SWITCH TEST *(continued)*

Figure F.11 – Motor protection switch location

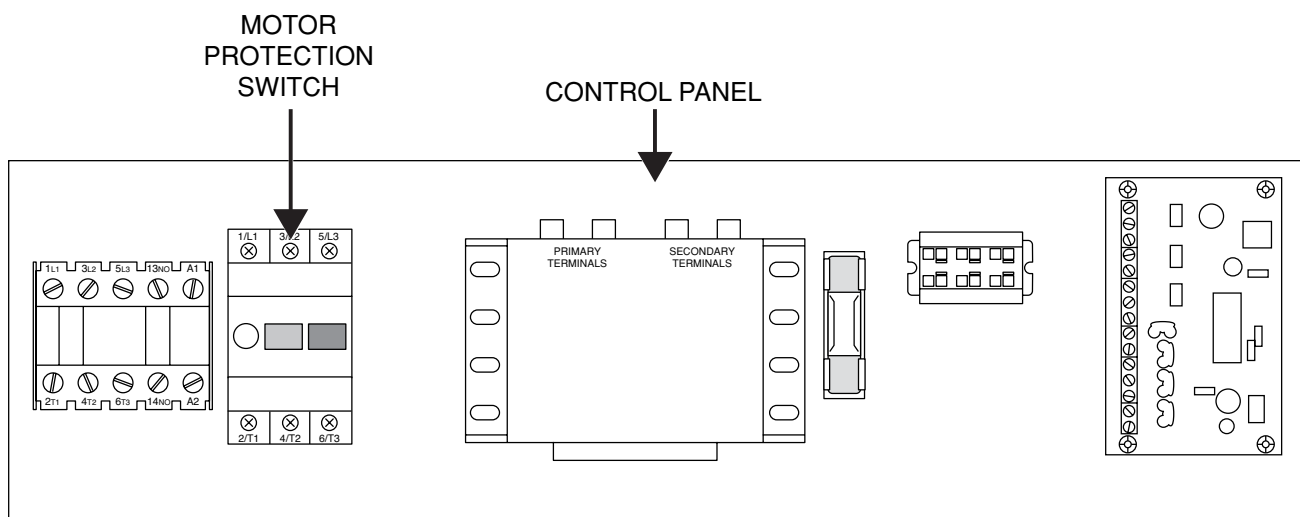

PROCEDURE

1. Remove the input power to the Mobiflex 400-MS(/HE).
2. Perform the **Case Cover Removal Procedure**.
3. Locate the motor protection switch on the control panel. See Figure F.11.
4. Using a volt/ohmmeter, perform the resistance test in **Table F.1**. See **Figure F.12**. See Wiring Diagram.
5. If any of the test produce questionable readings, using a Phillips screwdriver, label and disconnect all leads from the motor protection switch and retest. See **Figure F.12**. See Wiring Diagram.
6. If any of the tests fail, perform the **Motor Protection Switch Removal And Replacement Procedure**.
7. Using a Phillips screwdriver, connect the previously removed leads to the motor protection switch. See Wiring Diagram.
8. Perform the **Case Cover Replacement Procedure**.

MOTOR PROTECTION SWITCH TEST *(continued)*

Figure F.12 – Motor protection switch lead locations

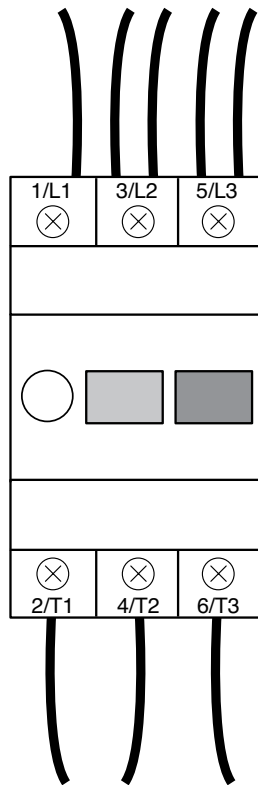

Table F.1 – Motor protection switch resistance tests

TEST POINTS	TEST POINTS	EXPECTED READING	CONDITION
1L1	2T1	NO RESISTANCE (ZERO OHMS)	POWER OFF, ON SWITCH ACTIVATED (CLOSED)
3L2	4T2	NO RESISTANCE (ZERO OHMS)	POWER OFF, ON SWITCH ACTIVATED (CLOSED)
5L3	6T3	NO RESISTANCE (ZERO OHMS)	POWER OFF, ON SWITCH ACTIVATED (CLOSED)
1L1	2T1	HIGH RESISTANCE (500,00 OHMS)	POWER OFF, ON SWITCH NOT ACTIVATED (OPEN)
3L2	4T2	HIGH RESISTANCE (500,00 OHMS)	POWER OFF, ON SWITCH NOT ACTIVATED (OPEN)
5L3	6T3	HIGH RESISTANCE (500,00 OHMS)	POWER OFF, ON SWITCH NOT ACTIVATED (OPEN)

MOTOR TEST

 **WARNING**

Service and repair should be performed only by Lincoln Electric factory trained personnel. Unauthorized repairs performed on this equipment may result in danger to the technician or machine operator and will invalidate your factory warranty. For your safety and to avoid electrical shock, please observe all safety notes and precautions detailed throughout this manual.

If for any reason you do not understand the test procedures or are unable to perform the test/repairs safely, contact the Lincoln Electric Automation Department for electrical troubleshooting assistance before you proceed. Call 1-888-935-3878.

TEST DESCRIPTION

This test will help determine if the Motor is functioning properly.

MATERIALS NEEDED

- Slotted Screwdriver
- Volt/Ohmmeter
- Wiring Diagram

MOTOR TEST *(continued)*

Figure F.13 – Motor lead location

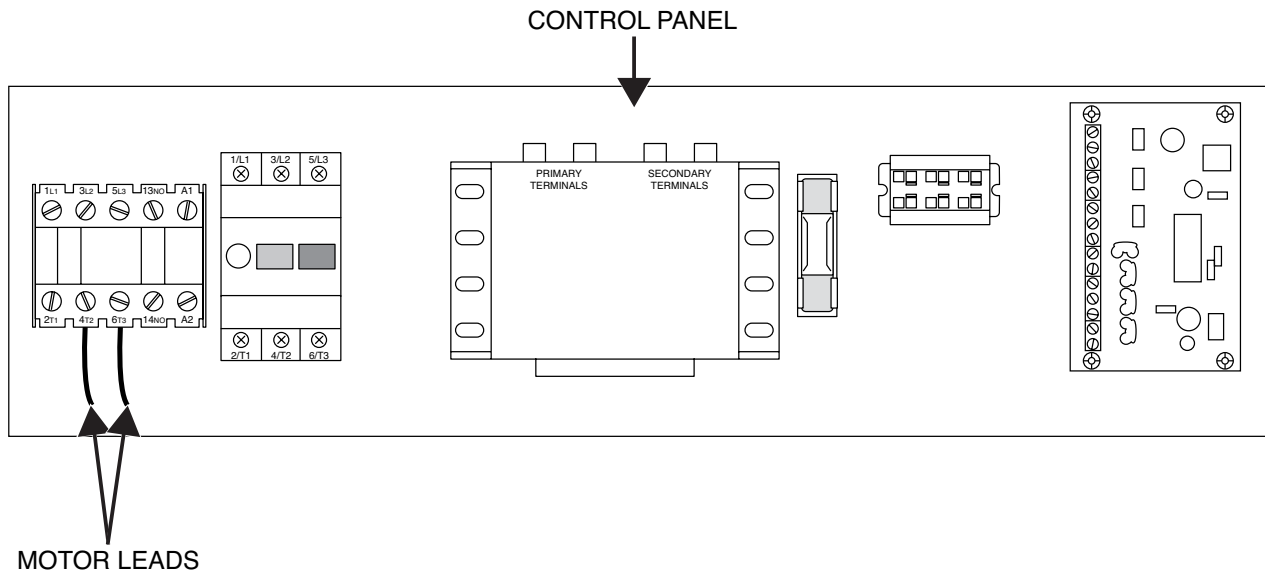

PROCEDURE

1. Remove the input power to the Mobiflex 400-MS/(HE).
2. Perform the **Case Cover Removal Procedure**.
3. Using a slotted screwdriver, label and disconnect the motor leads from terminals 4T2 and 6T3 of the contactor. See Figure F.13. See Wiring Diagram.
4. Using a volt/ohmmeter, check the resistance between the motor leads. Normal resistance should be about 0.8 to 1.2 Ohms. See Wiring Diagram.
5. Using a volt/ohmmeter, check the resistance between motor lead and ground. Normal resistance should be very high (500,000 Ohms). See Wiring Diagram.
6. If any of these test fail perform the **Motor Capacitor Test**.
7. If the motor capacitor tests OK, the motor may be faulty.
8. If faulty, perform the **Motor Removal And Replacement Procedure**.
9. Using a slotted screwdriver, connect the motor leads to terminals 4T2 and 6T3 of the contactor. See Wiring Diagram.
10. Perform the **Case Cover Replacement Procedure**.

MOTOR CAPACITOR TEST

WARNING

Service and repair should be performed only by Lincoln Electric factory trained personnel. Unauthorized repairs performed on this equipment may result in danger to the technician or machine operator and will invalidate your factory warranty. For your safety and to avoid electrical shock, please observe all safety notes and precautions detailed throughout this manual.

If for any reason you do not understand the test procedures or are unable to perform the test/repairs safely, contact the Lincoln Electric Automation Department for electrical troubleshooting assistance before you proceed. Call 1-888-935-3878.

TEST DESCRIPTION

This test will help determine if the Motor Capacitor is functioning properly.

MATERIALS NEEDED

- Phillips Screwdriver
- 7mm Nutdriver
- Capacitance Meter
- Wiring Diagram

MOTOR CAPACITOR TEST *(continued)*

Figure F.14 – Motor capacitor cover removal

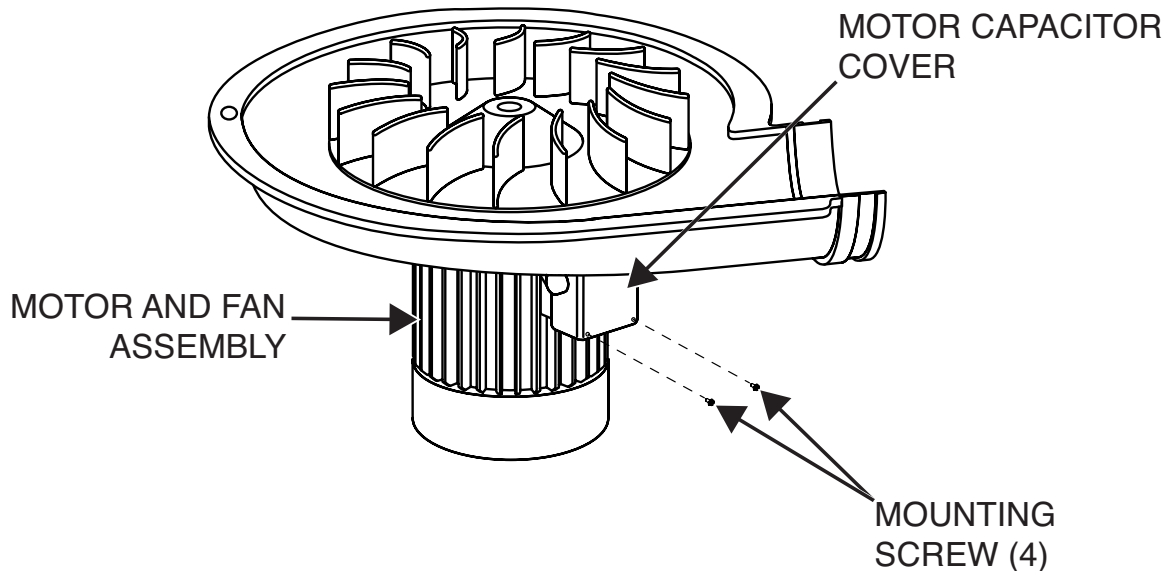

PROCEDURE

1. Remove the input power to the Mobiflex 400-MS(/HE) machine.
2. Perform the **Motor And Fan Removal Procedure**, to separate the motor and fan assembly from the machine.
3. Using a Phillips screwdriver, remove the four screws securing the motor capacitor cover. See Figure F.14.
4. Using a 7mm nutdriver, remove the nut securing the motor capacitor lead. See **Figure F.15**. See Wiring Diagram.
5. Using a capacitance meter, check the capacitance of the motor capacitor. It should measure $80\mu\text{F} \pm 5\%$. The capacitor is rated for 250VAC.
6. If measurement is significantly different the motor capacitor may be faulty.
7. If faulty, perform the **Motor Capacitor Removal And Replacement Procedure**.
8. Using a 7mm nutdriver, attach the nut securing the motor capacitor lead. See Wiring Diagram.
9. Using a Phillips screwdriver, attach the four screws securing the motor capacitor cover.
10. Perform the **Motor And Fan Replacement Procedure**.

MOTOR CAPACITOR TEST *(continued)*

Figure F.15 – Motor capacitor lead location

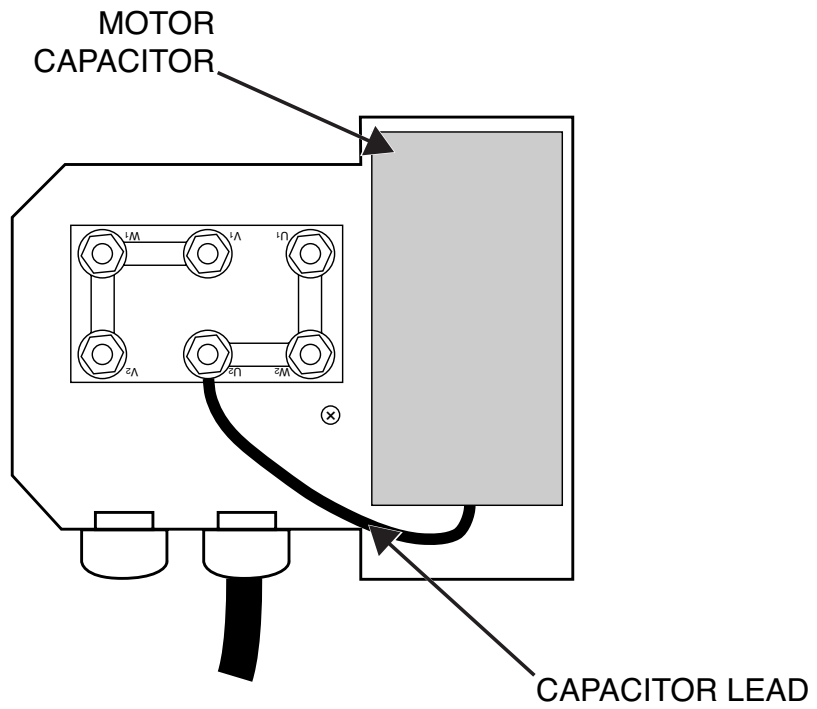

CONTROL PC BOARD AND CLEANING SOLENOID TEST

WARNING

Service and repair should be performed only by Lincoln Electric factory trained personnel. Unauthorized repairs performed on this equipment may result in danger to the technician or machine operator and will invalidate your factory warranty. For your safety and to avoid electrical shock, please observe all safety notes and precautions detailed throughout this manual.

If for any reason you do not understand the test procedures or are unable to perform the test/repairs safely, contact the Lincoln Electric Automation Department for electrical troubleshooting assistance before you proceed. Call 1-888-935-3878.

TEST DESCRIPTION

This test will help determine if the Control PC Board and Cleaning Solenoid are functioning properly.

MATERIALS NEEDED

Volt/Ohmmeter
Wiring Diagram

CONTROL PC BOARD AND CLEANING SOLENOID TEST *(continued)*

Figure F.16 – Control PC board location

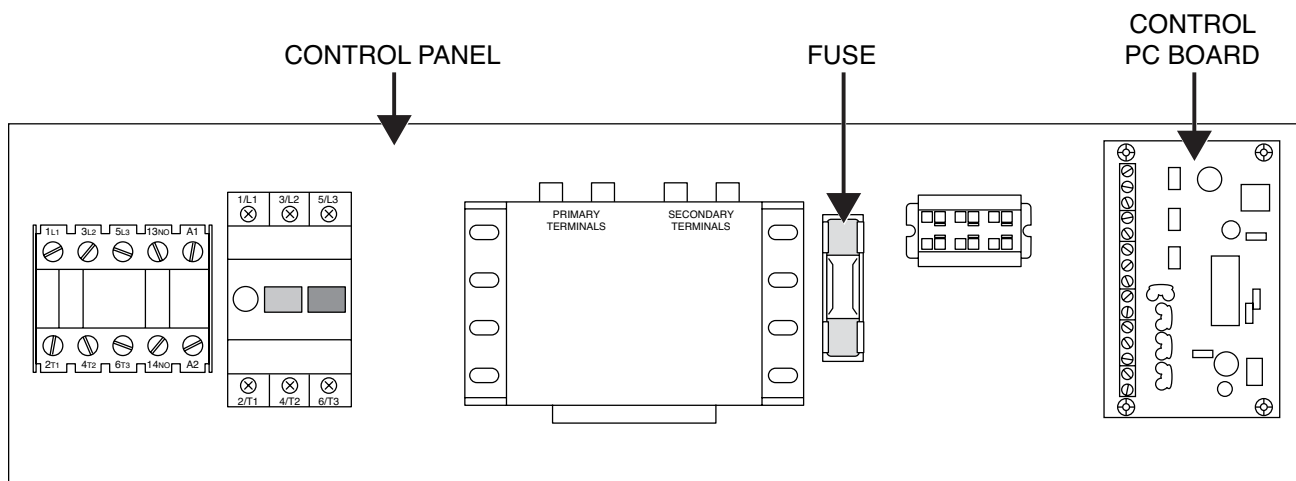

PROCEDURE

1. Remove the input power to the Mobiflex 400-MS(/HE).
2. Perform the **Case Cover Removal Procedure**.
3. Locate the control board. See Figure F.16.
4. Check for any missing, faulty or damaged leads or connections going to or from the control board. Also check the two orange leads connected to the cleaning light. See **Figure F.17**. See Wiring Diagram.
5. Carefully apply the correct input power to the Mobiflex 400-MS(/HE) machine.
6. Turn on the Mobiflex 400-MS(/HE).
7. Activate the cleaning on/off switch. See **Figure F.17**. The cleaning light should illuminate and the cleaning solenoid should cycle after about 5 - 10 seconds.
8. If the cleaning solenoid does not cycle, using a volt/ohmmeter, check for the presence of 24VAC at the white and brown leads at the top of the control board. See **Figure F.18**. See Wiring Diagram. This is the power from the transformer to the control board.
9. If the 24VAC is not present, check the fuse. See **Figure F.16**. See Wiring Diagram. Replace the fuse if blown.
10. If the fuse is OK, perform the **Transformer Test**.
11. If the 24VAC is present at the white and brown leads on the control board, check for the presence of 24VAC at the two black cleaning solenoid leads on the control board. The 24VAC will be present intermittently. See **Figure F.18**. See Wiring Diagram.
12. If the 24VAC is not present at the two black cleaning solenoid leads, the control board may be faulty.
13. If the 24VAC is present at the two black cleaning solenoid leads on the control board and the cleaning solenoid does not cycle, check the cleaning solenoid.
14. Remove the input power to the Mobiflex 400-MS(/HE).
15. To check the cleaning solenoid, remove the filter cover and filter cartridge to gain access to the cleaning solenoid. See **Figure F.19**.
16. Label and disconnect the two leads from the cleaning solenoid. See Wiring Diagram.
17. Using a volt/ohmmeter, check the resistance of the cleaning solenoid coil. Cleaning solenoid coil resistance should be 4.1 - 4.5 ohms. See Wiring Diagram. If the resistance reading is significantly different the cleaning solenoid may be faulty.

CONTROL PC BOARD AND CLEANING SOLENOID TEST *(continued)*

Figure F.17 – Cleaning on/off switch location

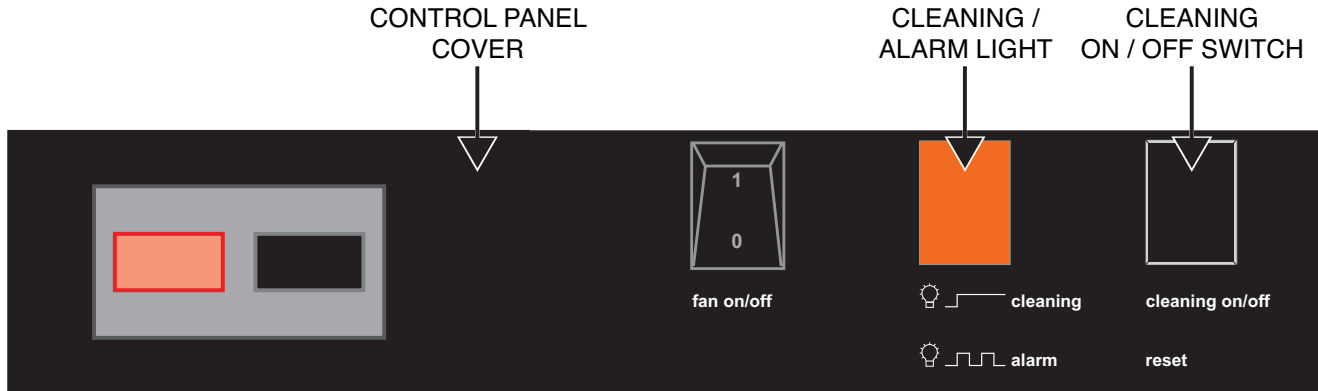

18. If the control board is faulty, perform the ***Control Board Removal And Replacement Procedure.***
19. If the cleaning solenoid is faulty, perform the ***Cleaning Solenoid Removal And Replacement Procedure.***
20. Connect the previously removed leads to the cleaning solenoid.
21. Place the filter cartridge and filter cover onto the machine.
22. Perform the ***Case Cover Replacement Procedure.***

CONTROL PC BOARD AND CLEANING SOLENOID TEST *(continued)*

Figure F.18 – Control board lead locations

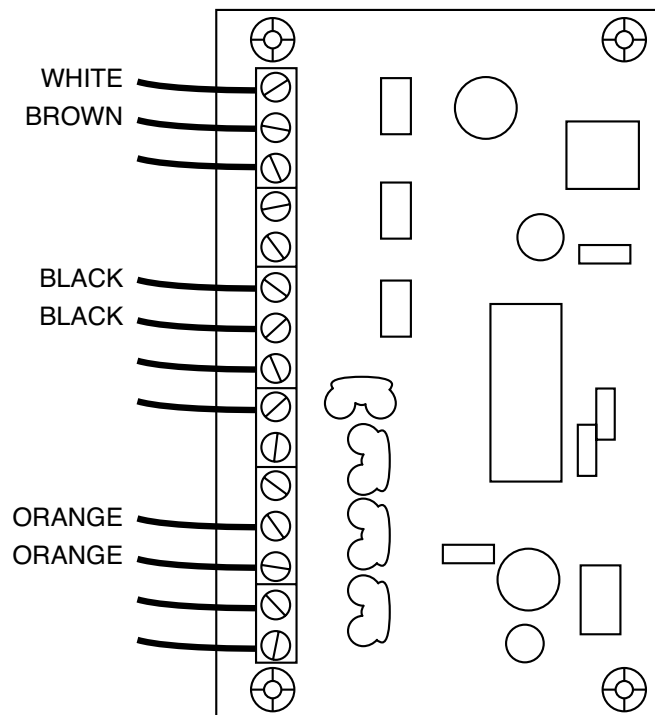
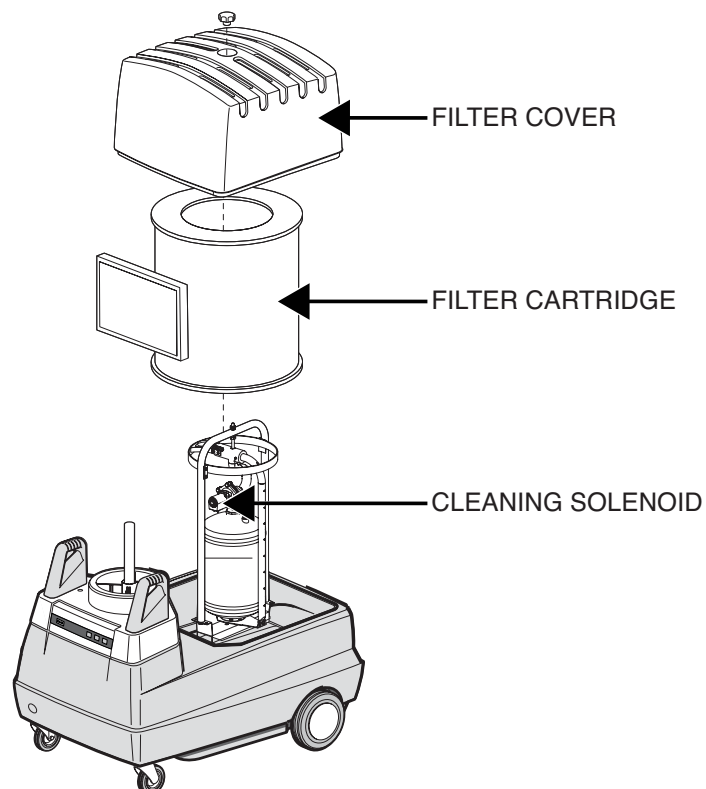

Figure F.19 – Solenoid location



EXTRACTION ARM REMOVAL AND REPLACEMENT PROCEDURE

WARNING

Service and repair should be performed only by Lincoln Electric factory trained personnel. Unauthorized repairs performed on this equipment may result in danger to the technician or machine operator and will invalidate your factory warranty. For your safety and to avoid electrical shock, please observe all safety notes and precautions detailed throughout this manual.

If for any reason you do not understand the test procedures or are unable to perform the test/repairs safely, contact the Lincoln Electric Automation Department for electrical troubleshooting assistance before you proceed. Call 1-888-935-3878.

TEST DESCRIPTION

This procedure will aid the technician in the removal and replacement of the Extraction Arm.

MATERIALS NEEDED

- 13mm Nutdriver
- 13mm Open End Wrench
- Strap
- Wiring Diagram

EXTRACTION ARM

REMOVAL AND REPLACEMENT PROCEDURE *(continued)*

Figure F.20 – Extraction arm tubes

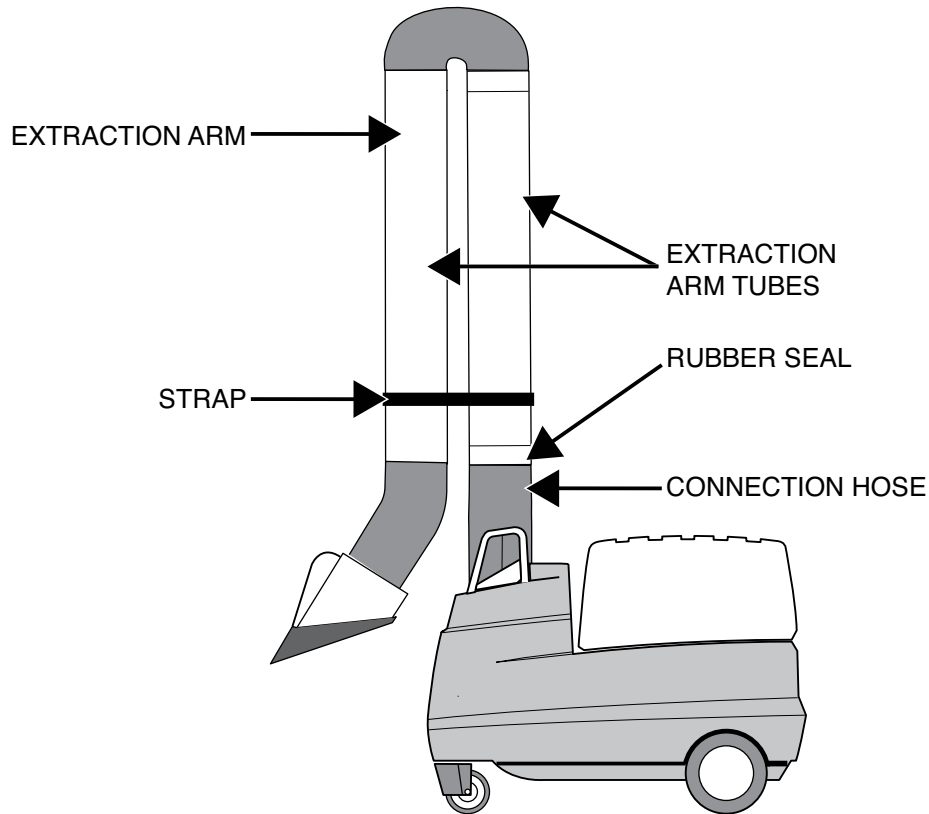

REMOVAL PROCEDURE

1. Remove the input power to the Mobiflex 400-MS(/HE).
2. Secure the Mobiflex 400-MS(/HE) in place by pressing down on the large front tab on the right (when facing the machine) front wheel. This will lock the wheel in place and keep the machine from moving while removing the extraction arm.

NOTE: It may be necessary to have the help of an assistant to perform the rest of this procedure.

3. Carefully position the extraction arm so both of the tubes are parallel with each other. See Figure F.20.
4. Using a strap, secure the two extraction arm tubes together. See Figure F.20.
5. Carefully roll the rubber seal in half, onto the extraction arm, to free the connection hose from the extraction arm. See Figure F.20.
6. Compress the connection hose to allow access to the extraction arm mounting hardware. See Figure F.20.
7. Disconnect the supply cable inside the base swivel mount. See Wiring Diagram.
8. Using a 13mm nutdriver and a 13mm open end wrench, remove the lower mounting nut and bolt. See **Figure F.21**.
9. Carefully tilt the extraction arm rearward so the extraction arm tube is resting on top of the filter area of the machine.

10. Using a 13mm nutdriver and a 13mm open end wrench, remove the upper mounting nut and bolt securing the extraction arm to the machine. See **Figure F.21**.
11. With the help of an assistant carefully lift the extraction arm up and off of the Mobiflex 400-MS(/HE).
12. Perform any necessary tests and / or removal and replacement procedures.
13. The extraction arm can now be replaced if necessary.

EXTRACTION ARM

REMOVAL AND REPLACEMENT PROCEDURE *(continued)*

Figure F.21 – Extraction arm removal

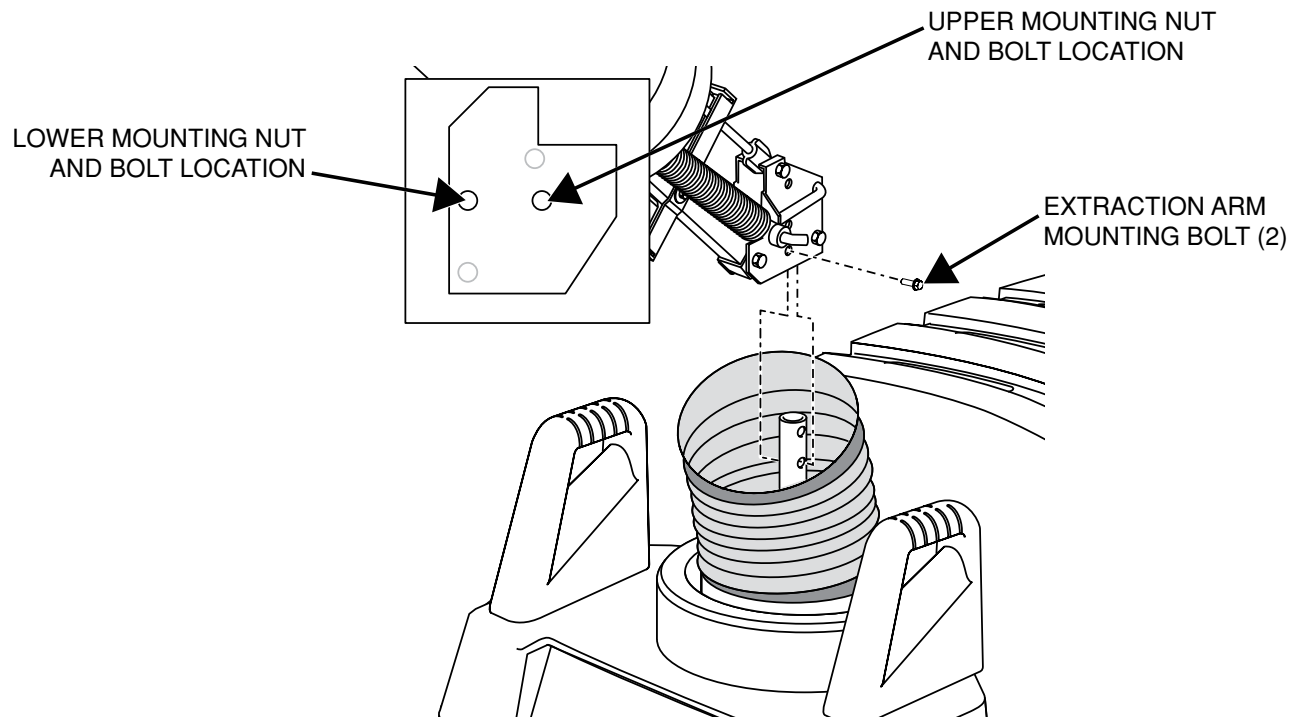

REPLACEMENT PROCEDURE

1. Secure the Mobiflex 400-MS(/HE) in place by pressing down on the large front tab on the right (when facing the machine) front wheel. This will lock the wheel in place and keep the machine from moving while replacing the extraction arm.
2. With the help of an assistant, carefully position the extraction arm onto the filter area of the Mobiflex 400-MS(/HE).
3. Using a 13mm nutdriver and a 13mm open end wrench, attach the upper mounting nut and bolt securing the extraction arm to the machine.
4. Carefully tilt the extraction arm upward so the extraction arm tube is in the vertical position.
5. Using a 13mm nutdriver and a 13mm open end wrench, attach the lower mounting nut and bolt securing the extraction arm to the machine.
6. Connect the supply cable inside the base swivel mount. See Wiring Diagram.
7. Position the connection hose over the end of the extraction arm.
8. Carefully roll the rubber seal in half, onto the connection hose, to secure the connection hose to the extraction arm.
9. Remove the strap securing the extraction arm tubes together.

NOTE: Use caution when removing the strap as this will release the spring tension on the extraction arm and the arm will snap into position.

FRONT WHEEL REMOVAL AND REPLACEMENT PROCEDURE

WARNING

Service and repair should be performed only by Lincoln Electric factory trained personnel. Unauthorized repairs performed on this equipment may result in danger to the technician or machine operator and will invalidate your factory warranty. For your safety and to avoid electrical shock, please observe all safety notes and precautions detailed throughout this manual.

If for any reason you do not understand the test procedures or are unable to perform the test/repairs safely, contact the Lincoln Electric Automation Department for electrical troubleshooting assistance before you proceed. Call 1-888-935-3878.

TEST DESCRIPTION

This procedure will aid the technician in the removal and replacement of the Front Wheel.

MATERIALS NEEDED

13mm Nutdriver

FRONT WHEEL REMOVAL AND REPLACEMENT PROCEDURE *(continued)*

Figure F.22 – Front wheel removal

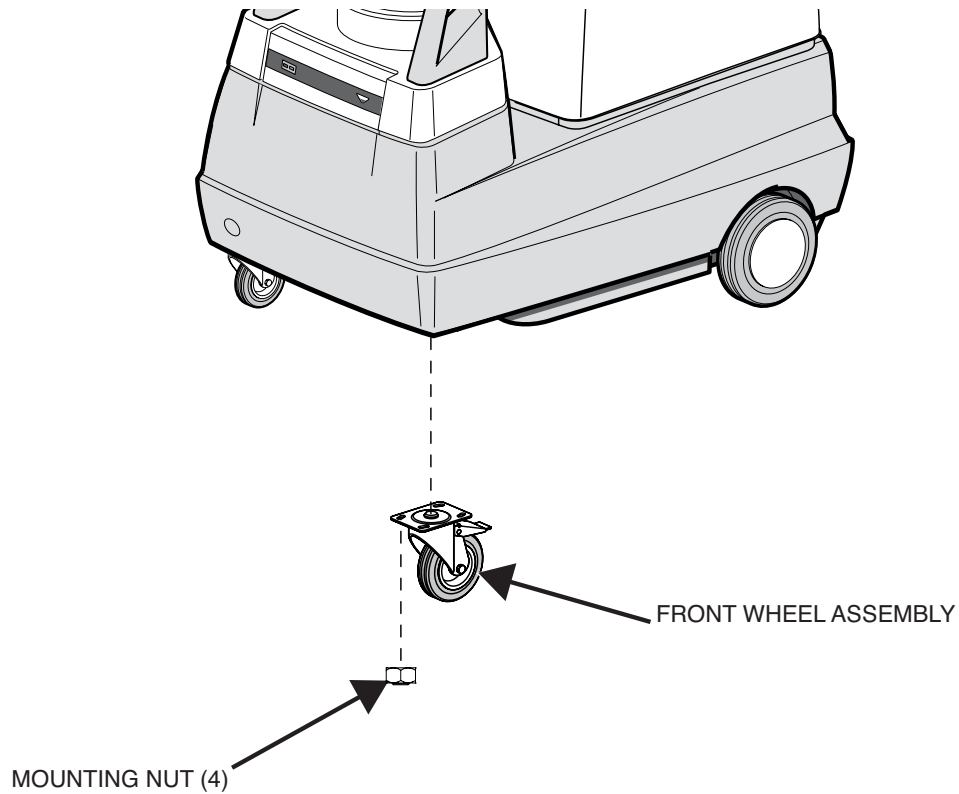

REMOVAL PROCEDURE

1. Remove the input power to the Mobiflex 400-MS(/HE) machine.
2. Perform the **Extraction Arm Removal Procedure**.
3. Carefully turn the machine on its side to gain access to front wheels.
4. Using a 13mm nutdriver, remove the four nuts securing the front wheel to the machine. See Figure F.22.
5. Slide the wheel off of the mounting posts.
6. The wheel can now be removed and replaced.

FRONT WHEEL REMOVAL AND REPLACEMENT PROCEDURE *(continued)*

REPLACEMENT PROCEDURE

1. With the machine on its side, position the new wheel onto the mounting posts.
2. Using a 13mm nutdriver, attach the four nuts securing the front wheel to the machine.
3. Carefully return the machine to its normal upright position.
4. Perform the ***Extraction Arm Replacement Procedure***.

TERMINAL BLOCK REMOVAL AND REPLACEMENT PROCEDURE

WARNING

Service and repair should be performed only by Lincoln Electric factory trained personnel. Unauthorized repairs performed on this equipment may result in danger to the technician or machine operator and will invalidate your factory warranty. For your safety and to avoid electrical shock, please observe all safety notes and precautions detailed throughout this manual.

If for any reason you do not understand the test procedures or are unable to perform the test/repairs safely, contact the Lincoln Electric Automation Department for electrical troubleshooting assistance before you proceed. Call 1-888-935-3878.

TEST DESCRIPTION

This procedure will aid the technician in the removal and replacement of the Terminal Block.

MATERIALS NEEDED

- Small Slotted Screwdriver
- Small Phillips Screwdriver
- Wiring Diagram

TERMINAL BLOCK

REMOVAL AND REPLACEMENT PROCEDURE *(continued)*

Figure F.23 – Terminal block lead locations

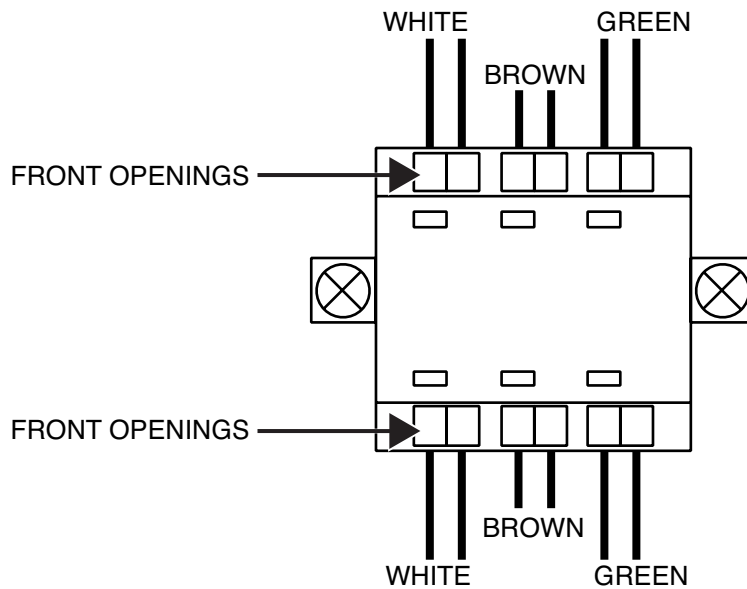

REMOVAL PROCEDURE

1. Remove the input power to the Mobiflex 400-MS(/HE) machine.
2. Perform the **Case Cover Removal Procedure**.
3. Label all leads connected to the terminal block. See Figure F.23. See Wiring Diagram.
4. Using a small slotted screwdriver, push in on front opening that corresponds to the lead being removed and pull lead out of the of the terminal block. Repeat this step for each lead connected to the terminal block. See **Figure F.24**. See Wiring diagram.
5. Using a small Phillips screwdriver, remove the two screws securing the terminal block to the machine. See **Figure F.24**.
6. The terminal block can now be removed and replaced.

TERMINAL BLOCK

REMOVAL AND REPLACEMENT PROCEDURE *(continued)*

Figure F.24 – Terminal block mounting screw locations

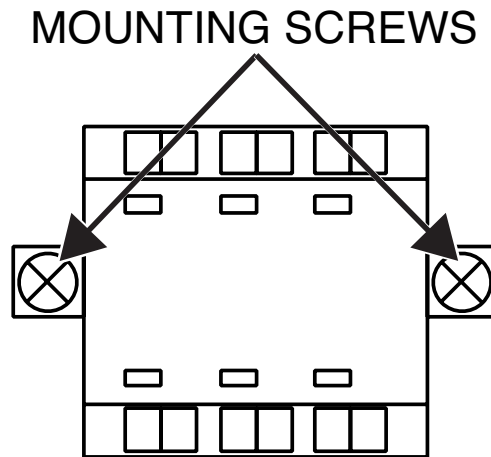

REPLACEMENT PROCEDURE

1. Carefully position new terminal block onto machine.
2. Using a small Phillips screwdriver, attach the two screws securing the terminal block to the machine.

NOTE: Do not over tighten screws as this may cause damage to the machine.

3. Using a small slotted screwdriver, push in on front opening that corresponds to the lead being connected and push lead into the terminal block. Repeat this step for each lead connected to the terminal block. See Wiring Diagram.
4. Perform the ***Case Cover Removal Procedure***.

CONTACTOR REMOVAL AND REPLACEMENT PROCEDURE

WARNING

Service and repair should be performed only by Lincoln Electric factory trained personnel. Unauthorized repairs performed on this equipment may result in danger to the technician or machine operator and will invalidate your factory warranty. For your safety and to avoid electrical shock, please observe all safety notes and precautions detailed throughout this manual.

If for any reason you do not understand the test procedures or are unable to perform the test/repairs safely, contact the Lincoln Electric Automation Department for electrical troubleshooting assistance before you proceed. Call 1-888-935-3878.

TEST DESCRIPTION

This procedure will aid the technician in the removal and replacement of the Contactor.

MATERIALS NEEDED

Slotted Screwdriver
Wiring Diagram

CONTACTOR REMOVAL AND REPLACEMENT PROCEDURE *(continued)*

Figure F.25 – Contactor lead locations

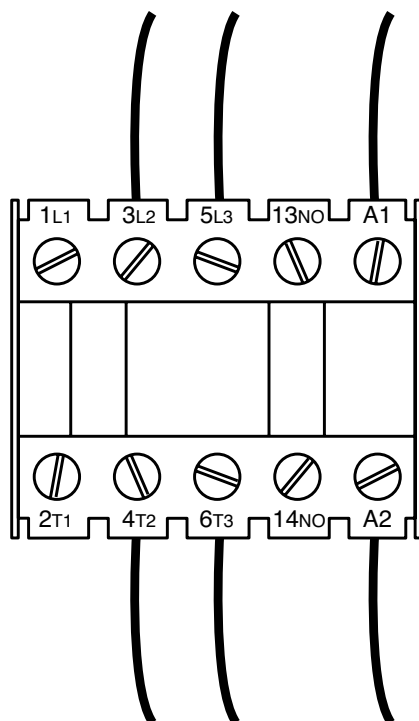

REMOVAL PROCEDURE

1. Remove the input power to the Mobiflex 400-MS(/HE).
2. Perform the **Case Cover Removal Procedure**.
3. Using a slotted screwdriver, label and disconnect the six leads from contactor terminals 3L2, 4T2, 5L3, 6T3, A1 and A2. See Figure F.25. See Wiring Diagram.
4. Using a slotted screwdriver, gently lift the top tab and press down on the contactor body to remove the contactor from the DIN rail.
5. The contactor can now be removed and replaced.

CONTACTOR REMOVAL AND REPLACEMENT PROCEDURE *(continued)*

REPLACEMENT PROCEDURE

1. Carefully position new contactor in front of DIN rail.
2. Place the bottom tabs of the contactor on the DIN rail and rock the contactor upward onto the DIN rail until it snaps onto the DIN rail.
3. Using a slotted screwdriver, attach the previously removed six leads to contactor terminals 3L2, 4T2, 5L3, 6T3, A1 and A2. See Wiring Diagram.
4. Perform the ***Case Cover Replacement Procedure***.

TRANSFORMER REMOVAL AND REPLACEMENT PROCEDURE

WARNING

Service and repair should be performed only by Lincoln Electric factory trained personnel. Unauthorized repairs performed on this equipment may result in danger to the technician or machine operator and will invalidate your factory warranty. For your safety and to avoid electrical shock, please observe all safety notes and precautions detailed throughout this manual.

If for any reason you do not understand the test procedures or are unable to perform the test/repairs safely, contact the Lincoln Electric Automation Department for electrical troubleshooting assistance before you proceed. Call 1-888-935-3878.

TEST DESCRIPTION

This procedure will aid the technician in the removal and replacement of the Transformer.

MATERIALS NEEDED

Phillips Screwdriver
Wiring Diagram

TRANSFORMER REMOVAL AND REPLACEMENT PROCEDURE *(continued)*

Figure F.26 – Transformer lead locations

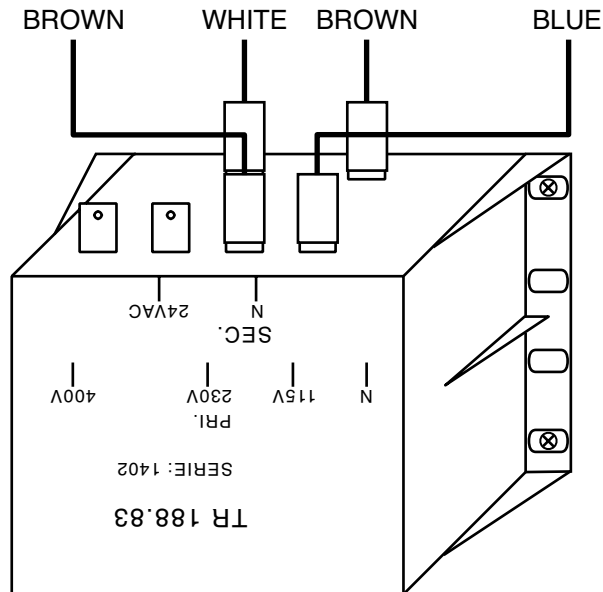

REMOVAL PROCEDURE

1. Remove the input power to the Mobiflex 400-MS(/HE).
2. Perform the **Case Cover Removal Procedure**.
3. Label and disconnect the four leads from the transformer. See Figure F.26. See Wiring Diagram.
4. Using a Phillips screwdriver, remove the four screws securing the transformer to the machine. See **Figure F.27**.
5. The transformer can now be removed and replaced.

TRANSFORMER REMOVAL AND REPLACEMENT PROCEDURE *(continued)*

Figure F.27 – Transformer mounting screw locations

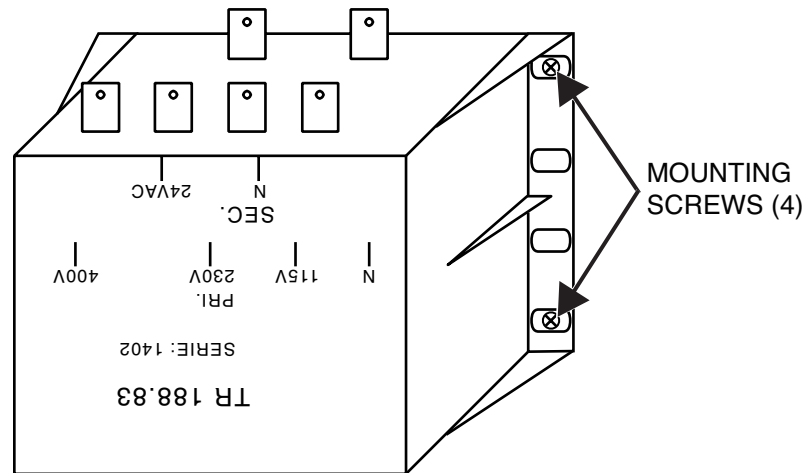

REPLACEMENT PROCEDURE

1. Carefully position new transformer onto machine.
2. Using a Phillips screwdriver, attach the four screws securing the transformer to the machine.
3. Connect the four previously removed leads to the transformer.
See Wiring Diagram.
4. Perform the **Case Cover Replacement Procedure**.

MOTOR PROTECTION SWITCH REMOVAL AND REPLACEMENT PROCEDURE

WARNING

Service and repair should be performed only by Lincoln Electric factory trained personnel. Unauthorized repairs performed on this equipment may result in danger to the technician or machine operator and will invalidate your factory warranty. For your safety and to avoid electrical shock, please observe all safety notes and precautions detailed throughout this manual.

If for any reason you do not understand the test procedures or are unable to perform the test/repairs safely, contact the Lincoln Electric Automation Department for electrical troubleshooting assistance before you proceed. Call 1-888-935-3878.

TEST DESCRIPTION

This procedure will aid the technician in the removal and replacement of the Motor Protection Switch.

MATERIALS NEEDED

Phillips Screwdriver
Wiring Diagram

MOTOR PROTECTION SWITCH

REMOVAL AND REPLACEMENT PROCEDURE *(continued)*

Figure F.28 – Motor protection switch lead locations

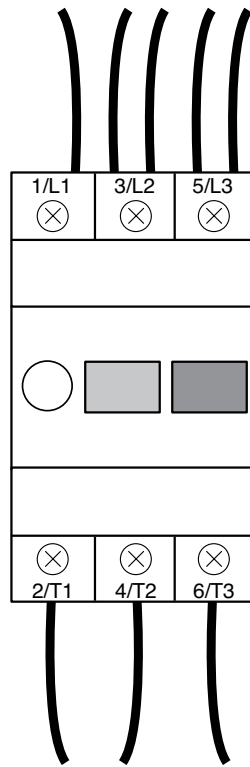

REMOVAL PROCEDURE

1. Remove the input power to the Mobiflex 400-MS(/HE).
2. Perform the **Case Cover Removal Procedure**.
3. Using a Phillips screwdriver, label and disconnect the eight leads connected to motor protection switch terminals 1/L1, 2/T1, 3/L2, 4/T2, 5/L3 and 6/T3. See Figure F.58. See Wiring Diagram.
4. Carefully pry the motor protection switch assembly up and away from the DIN rail.
5. The motor protection relay can now be removed and replaced.

MOTOR PROTECTION SWITCH REMOVAL AND REPLACEMENT PROCEDURE *(continued)*

REPLACEMENT PROCEDURE

1. Position the new motor protection switch in front of the DIN rail.
2. Rest the upper mounting tabs, on the rear of the motor protection switch, onto the DIN rail and rock the motor protection switch assembly downward until it snaps onto the DIN rail.
3. Using a Phillips screwdriver, connect the previously removed eight leads to motor protection switch terminals 1/L1, 2/T1, 3/L2, 4/T2, 5/L3 and 6/T3. See Wiring Diagram.
4. Perform the ***Case Cover Replacement Procedure***.

MOTOR AND FAN REMOVAL AND REPLACEMENT PROCEDURE

WARNING

Service and repair should be performed only by Lincoln Electric factory trained personnel. Unauthorized repairs performed on this equipment may result in danger to the technician or machine operator and will invalidate your factory warranty. For your safety and to avoid electrical shock, please observe all safety notes and precautions detailed throughout this manual.

If for any reason you do not understand the test procedures or are unable to perform the test/repairs safely, contact the Lincoln Electric Automation Department for electrical troubleshooting assistance before you proceed. Call 1-888-935-3878.

TEST DESCRIPTION

This procedure will aid the technician in the removal and replacement of the Motor and Fan Assembly.

MATERIALS NEEDED

- Small Slotted Screwdriver
- Phillips Screwdriver
- 7mm Nutdriver
- Gear Puller
- 13mm Socket
- 13mm Open End Wrench
- Wiring Diagram

MOTOR AND FAN REMOVAL AND REPLACEMENT PROCEDURE *(continued)*

Figure F.29 – Solenoid lead locations

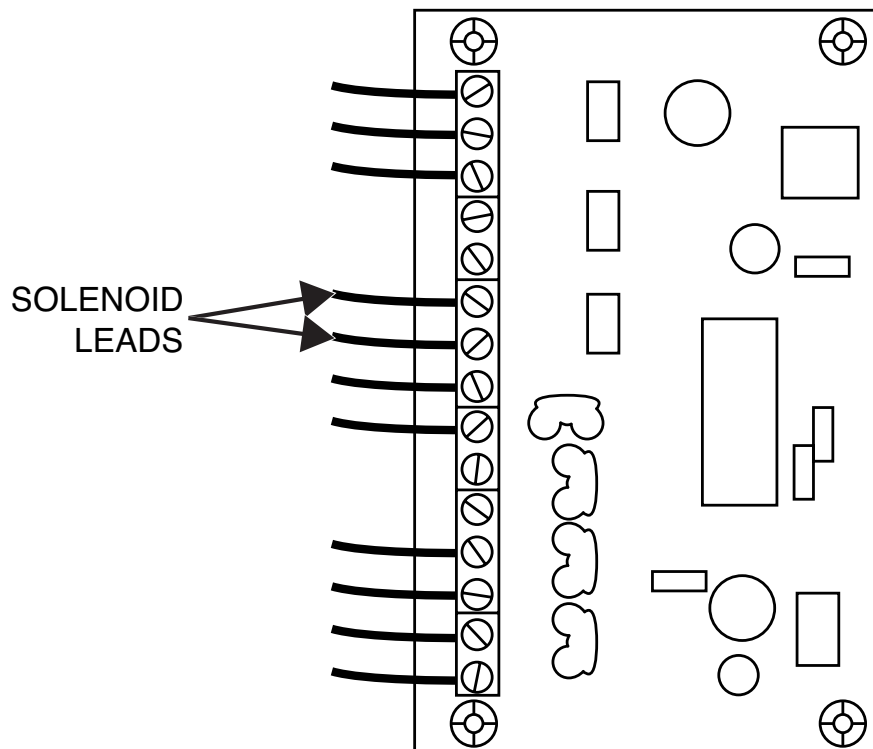

REMOVAL PROCEDURE

1. Remove the input power to the Mobiflex 400-MS(/HE) machine.
 2. Perform the **Case Cover Removal Procedure**.
 3. Empty the dustbin. See Maintenance section of **Operators Manual**.
 4. Carefully turn the machine on its side to gain access to the motor.
 5. Using a small slotted screwdriver, label and disconnect the solenoid leads from the control board. See Figure F.29. See Wiring Diagram.
 6. Loosen the plastic nut on the cable grommet and pull the solenoid leads to get enough slack to allow for the removal of the motor and fan assembly.
 7. Using a Phillips screwdriver, remove the nine screws securing the motor and fan assembly to the machine. See **Figure F.30**.
- NOTE:** Do not try to fully remove motor as the power cord is still attached.
8. Using a Phillips screwdriver, remove the four screws securing the motor capacitor cover. See **Figure F.31**.
 9. Using a 7mm nutdriver, remove the nut securing each of the two motor leads. See **Figure F.32**. See Wiring Diagram.
 10. Using a Phillips screwdriver, remove the screw securing the ground lead to the motor case. See **Figure F.32**. See Wiring Diagram.
 11. Loosen the plastic nut on the cable grommet and pull the cables out of the motor.
 12. The motor and fan assembly is now free of the machine.
 13. Using a gear puller, attach the gear puller to the fan and remove the fan from the fan housing and motor assembly. See **Figure F.33**. Note placement of the washer between the fan and fan housing.
 14. Using a 13mm socket and a 13mm open end wrench, remove the four nuts and bolts securing the motor assembly to the fan housing. See **Figure F.33**.
 15. The motor, fan and fan housing can now be removed and replaced.

MOTOR AND FAN REMOVAL AND REPLACEMENT PROCEDURE *(continued)*

Figure F.30 – Motor and fan assembly removal

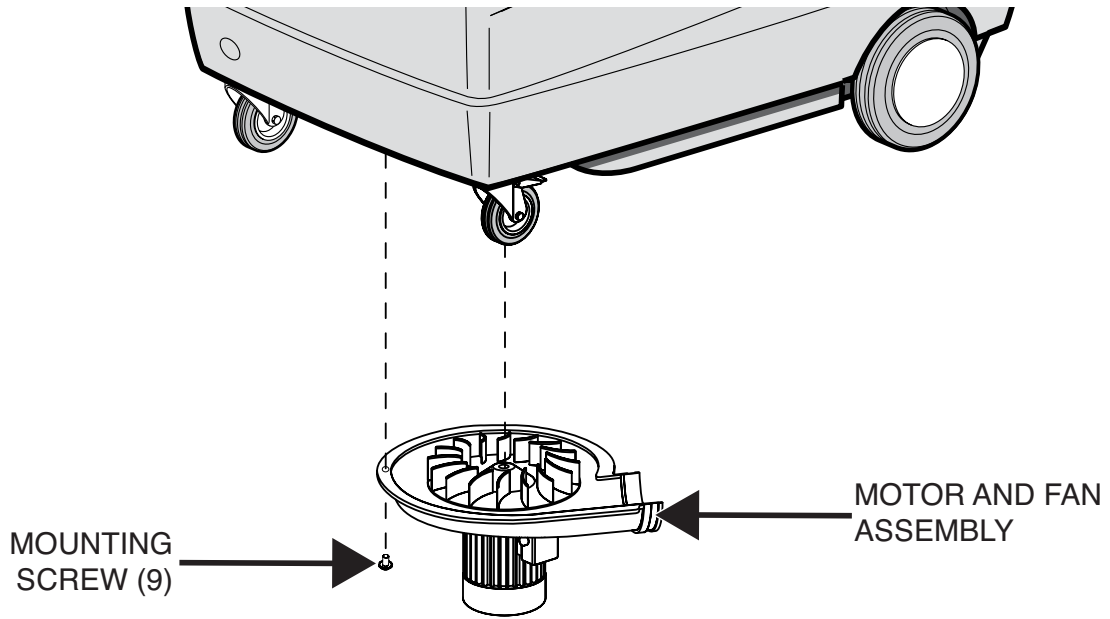
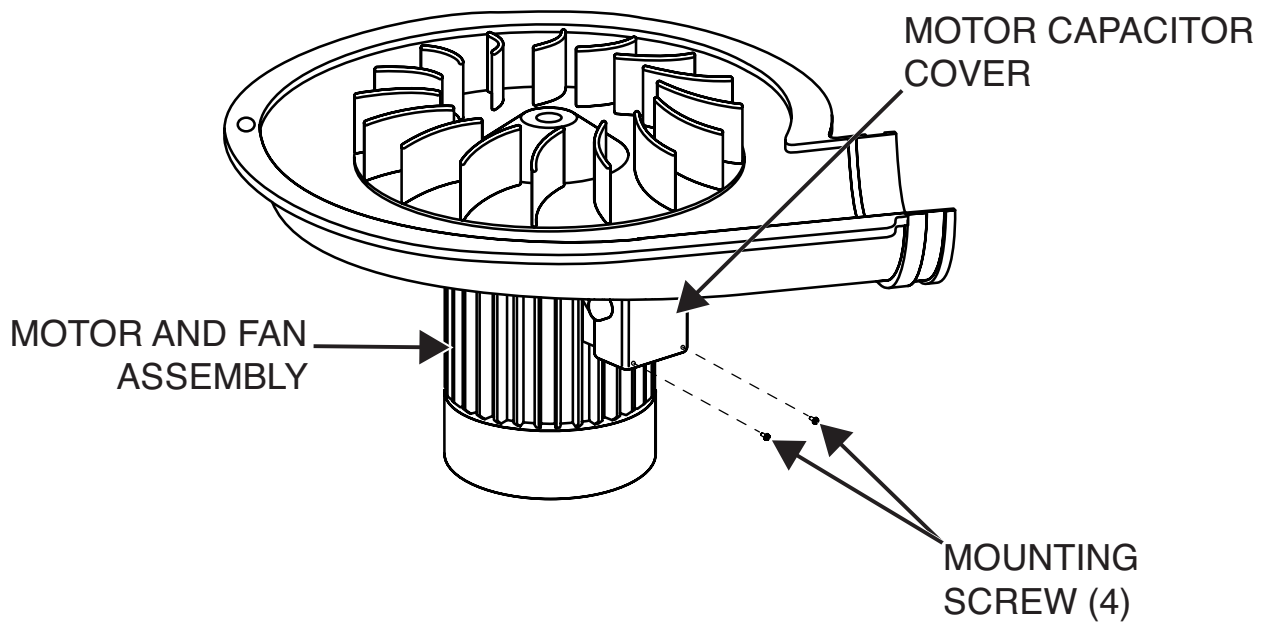

Figure F.31 – Motor capacitor cover removal



MOTOR AND FAN REMOVAL AND REPLACEMENT PROCEDURE *(continued)*

Figure F.32 – Motor lead locations

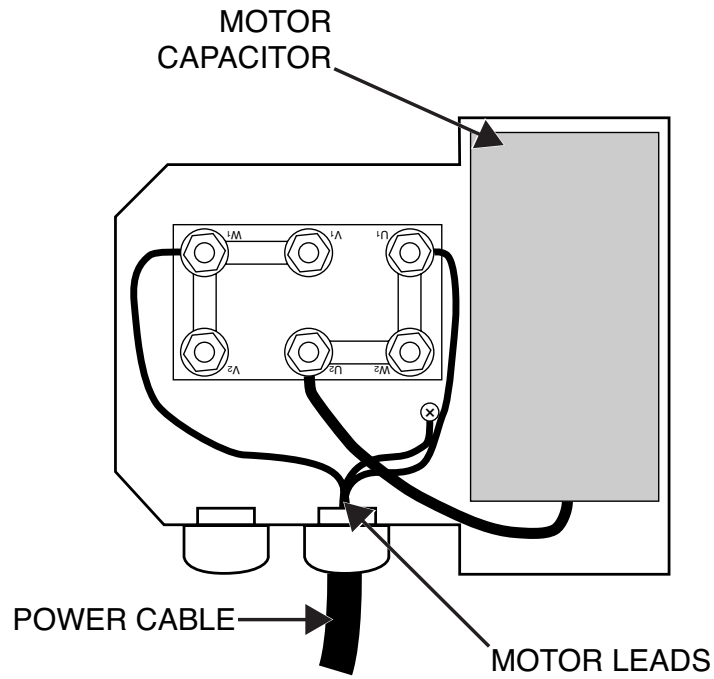
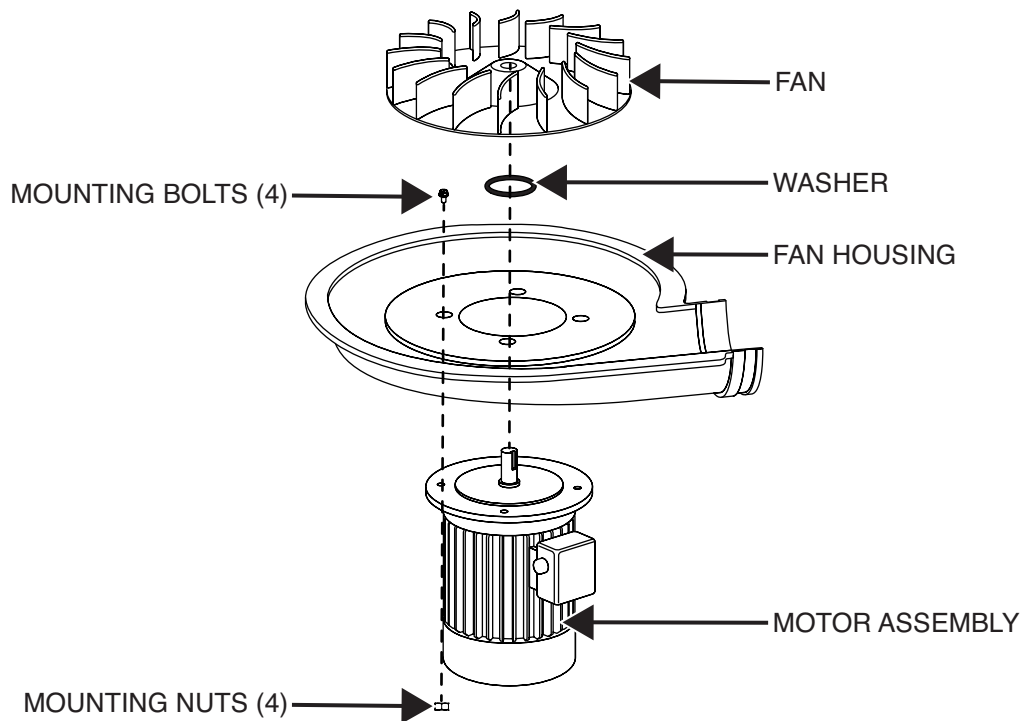

Figure F.33 – Motor and fan assembly removal



MOTOR AND FAN REMOVAL AND REPLACEMENT PROCEDURE *(continued)*

REPLACEMENT PROCEDURE

1. Carefully place the motor assembly upright on a flat surface.
2. Carefully place the fan housing on top of the motor assembly.
3. Using a 13mm socket and a 13mm open end wrench, attach the four nuts and bolts securing the fan housing to the motor assembly.
4. Place the previously removed washer on top of the fan housing.
5. Carefully position the fan onto the fan housing.
6. Using a gear puller, attach the gear puller to the fan and attach the fan to the fan housing and motor assembly.
7. Loosen the plastic nut on the cable grommet and pull the motor cables into the motor capacitor compartment.
8. Using a Phillips screwdriver, attach the screw securing the ground lead to the motor case. See Wiring Diagram.
9. Using a 7mm nutdriver, attach the nut securing each of the two motor leads. See Wiring Diagram.
10. Using a Phillips screwdriver, attach the four screws securing the motor capacitor cover.
11. Carefully position the motor and fan assembly into the machine. The machine should still be on its side to allow for installation of the motor and fan assembly.
12. Using a Phillips screwdriver, attach the nine screws securing the motor and fan assembly to the machine.
13. Pull the solenoid leads into the control panel to allow for connection to the control board. Tighten the plastic nut on the cable grommet to secure the solenoid leads in place.
14. Using a small slotted screwdriver, connect the solenoid leads to the control board. See Wiring Diagram.
15. Carefully return the machine to its upright position.
16. Perform the **Case Cover Replacement Procedure**.

MOTOR CAPACITOR REMOVAL AND REPLACEMENT PROCEDURE

WARNING

Service and repair should be performed only by Lincoln Electric factory trained personnel. Unauthorized repairs performed on this equipment may result in danger to the technician or machine operator and will invalidate your factory warranty. For your safety and to avoid electrical shock, please observe all safety notes and precautions detailed throughout this manual.

If for any reason you do not understand the test procedures or are unable to perform the test/repairs safely, contact the Lincoln Electric Automation Department for electrical troubleshooting assistance before you proceed. Call 1-888-935-3878.

TEST DESCRIPTION

This procedure will aid the technician in the removal and replacement of the Motor Capacitor.

MATERIALS NEEDED

- Phillips Screwdriver
- 7mm Nutdriver
- Wiring Diagram

MOTOR CAPACITOR

REMOVAL AND REPLACEMENT PROCEDURE *(continued)*

Figure F.34 – Motor capacitor cover removal

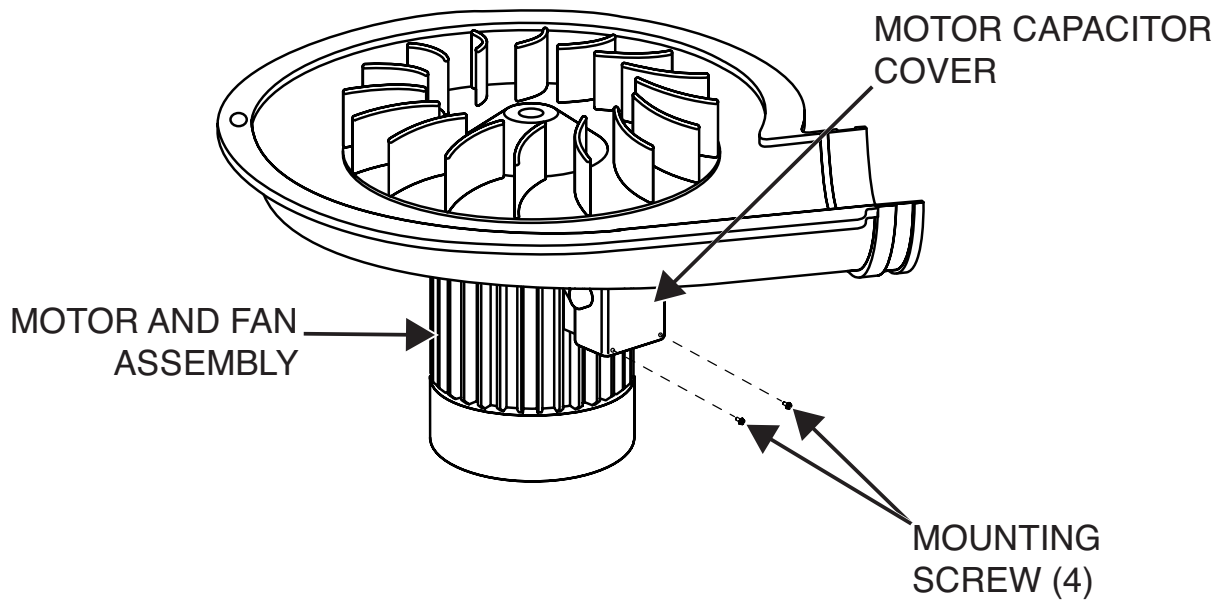

REMOVAL PROCEDURE

1. Remove the input power to the Mobiflex 400-MS(/HE) machine.
2. Perform the **Case Cover Removal Procedure**.
3. Perform the **Motor And Fan Removal Procedure**, to separate the motor and fan assembly from the machine.
4. Using a Phillips screwdriver, remove the four screws securing the motor capacitor cover. See Figure F.34.
5. Using a 7mm nutdriver, remove the nut securing the motor capacitor lead. See **Figure F.35**. See Wiring Diagram.
6. Remove the splice connecting the capacitor lead to the motor lead. See Wiring Diagram.
7. The motor capacitor can now be removed and replaced.

MOTOR CAPACITOR REMOVAL AND REPLACEMENT PROCEDURE *(continued)*

Figure F.35 – Motor capacitor lead location

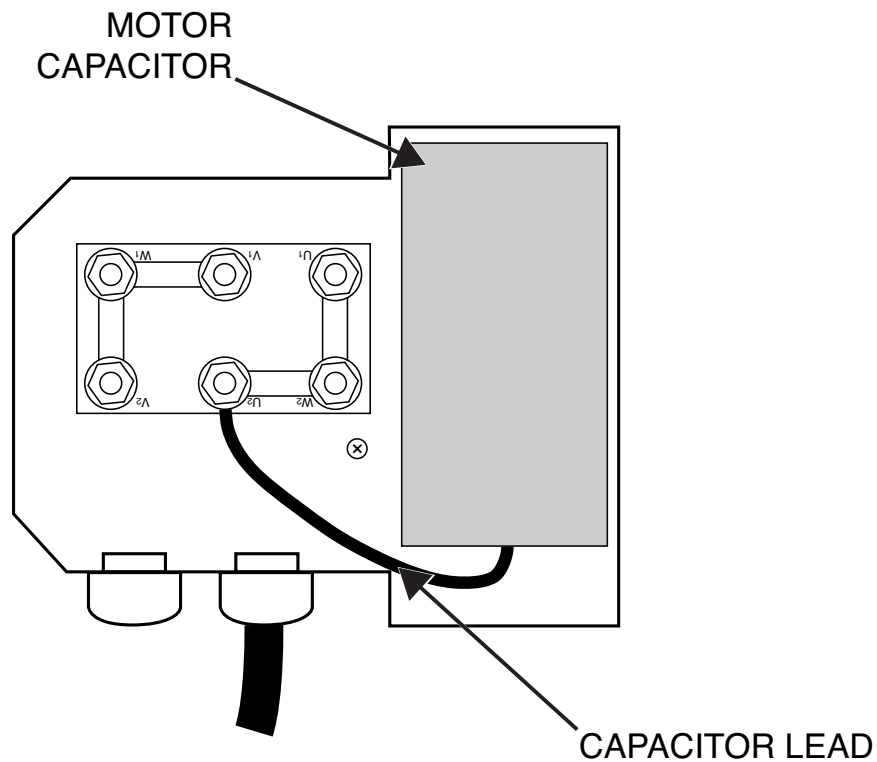

REPLACEMENT PROCEDURE

1. Carefully position the motor capacitor into the motor capacitor compartment on the side of the motor and fan assembly.
2. Attach a cable splice joining the capacitor lead and the motor lead. See Wiring Diagram.
3. Using a 7mm nutdriver, attach the nut securing the motor capacitor lead. See Wiring Diagram.
4. Using a Phillips screwdriver, attach the four screws securing the motor capacitor cover.
5. Perform the **Motor And Fan Replacement Procedure**.
6. Perform the **Case Cover Replacement Procedure**.

CONTROL PC BOARD REMOVAL AND REPLACEMENT PROCEDURE

WARNING

Service and repair should be performed only by Lincoln Electric factory trained personnel. Unauthorized repairs performed on this equipment may result in danger to the technician or machine operator and will invalidate your factory warranty. For your safety and to avoid electrical shock, please observe all safety notes and precautions detailed throughout this manual.

If for any reason you do not understand the test procedures or are unable to perform the test/repairs safely, contact the Lincoln Electric Automation Department for electrical troubleshooting assistance before you proceed. Call 1-888-935-3878.

TEST DESCRIPTION

This procedure will aid the technician in the removal and replacement of the Control PC Board.

MATERIALS NEEDED

Small Slotted Screwdriver
Wiring Diagram

CONTROL PC BOARD

REMOVAL AND REPLACEMENT PROCEDURE *(continued)*

Figure F.36 – Control PC board lead locations

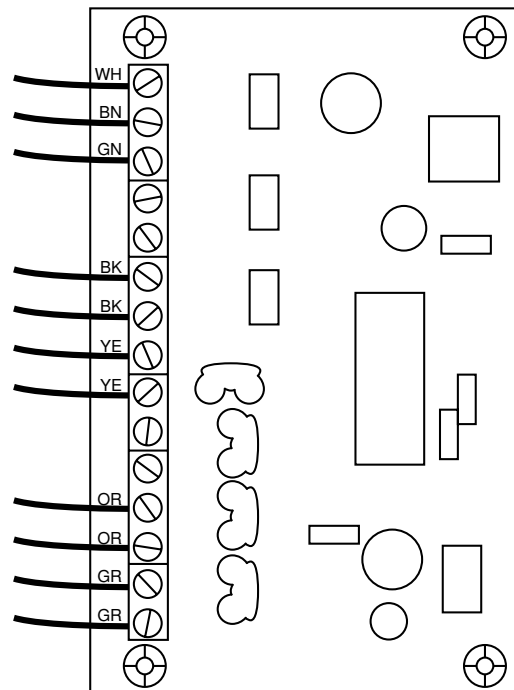

REMOVAL PROCEDURE

1. Remove the input power to the Mobiflex 400-MS(/HE).
2. Perform the **Case Cover Removal Procedure**.
3. Using a small slotted screwdriver, label and disconnect the eleven leads from the control board. See Figure F.36. See Wiring Diagram.
4. Remove the control board from the four plastic stand-offs. See **Figure F.37**.
5. The control board can now be replaced.

CONTROL PC BOARD

REMOVAL AND REPLACEMENT PROCEDURE *(continued)*

Figure F.37 – Control PC board mounting points

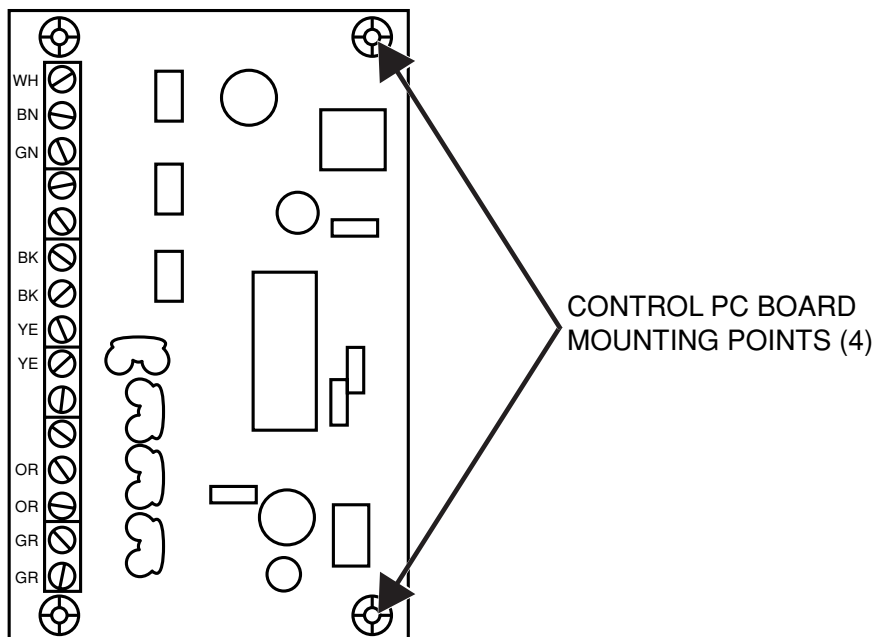

REPLACEMENT PROCEDURE

1. Carefully secure the control PC board onto the four plastic stand offs.
2. Using a small slotted screwdriver, connect the eleven previously removed leads to the control board. See Wiring Diagram.
3. Perform the **Case Cover Replacement Procedure**.

CLEANING SOLENOID REMOVAL AND REPLACEMENT PROCEDURE

WARNING

Service and repair should be performed only by Lincoln Electric factory trained personnel. Unauthorized repairs performed on this equipment may result in danger to the technician or machine operator and will invalidate your factory warranty. For your safety and to avoid electrical shock, please observe all safety notes and precautions detailed throughout this manual.

If for any reason you do not understand the test procedures or are unable to perform the test/repairs safely, contact the Lincoln Electric Automation Department for electrical troubleshooting assistance before you proceed. Call 1-888-935-3878.

TEST DESCRIPTION

This procedure will aid the technician in the removal and replacement of the Cleaning Solenoid.

MATERIALS NEEDED

Needle Nose Pliers
Wiring Diagram

CLEANING SOLENOID REMOVAL AND REPLACEMENT PROCEDURE *(continued)*

Figure F.38 – Solenoid removal

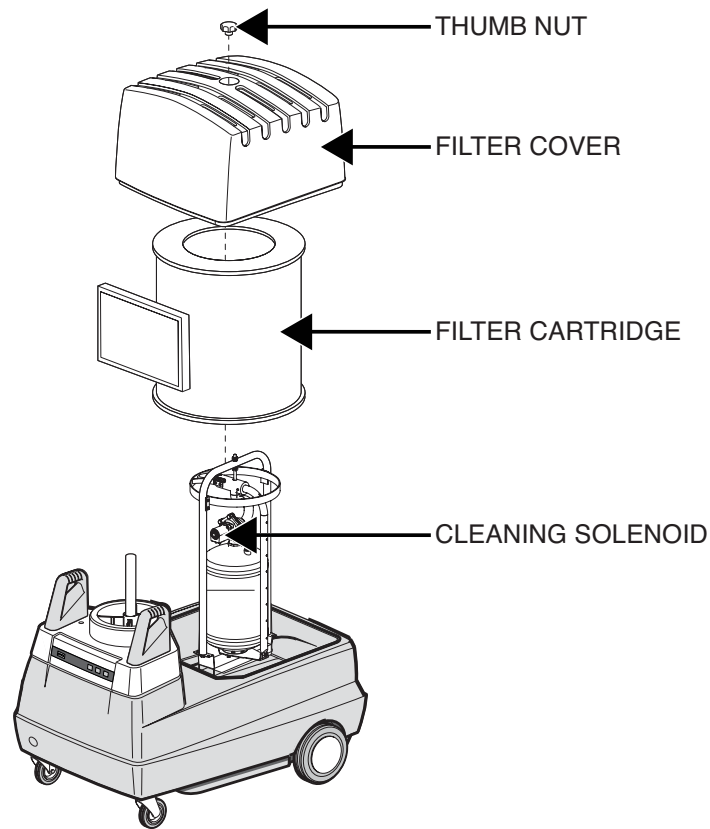

REMOVAL PROCEDURE

1. Remove the input power to the Mobiflex 400-MS(/HE).
2. Loosen the thumb nut securing the filter cover. See Figure F.38.
3. Carefully lift the filter cover off the machine and set aside. See Figure F.38.
4. Carefully lift the filter cartridge out of the machine. See Figure F.38.
5. Label and disconnect the two leads from the solenoid. See Wiring Diagram.
6. Using needle nose pliers, remove the clip on the rear of the solenoid. See Figure F.38.
7. Carefully pull the solenoid off of the mounting post.
8. The solenoid can now be replaced.

CLEANING SOLENOID REMOVAL AND REPLACEMENT PROCEDURE *(continued)*

REPLACEMENT PROCEDURE

1. Carefully place the new solenoid onto the mounting post.
2. Connect the two previously removed leads to the solenoid. See Wiring Diagram.
3. Carefully place the filter cartridge into the machine.
4. Carefully place the filter cover onto the machine.
5. Using the thumb nut secure the filter cover in place.

TABLE OF CONTENTS - DIAGRAMS SECTION -

DiagramsSection G

Diagrams G-2

ELECTRICAL DIAGRAM

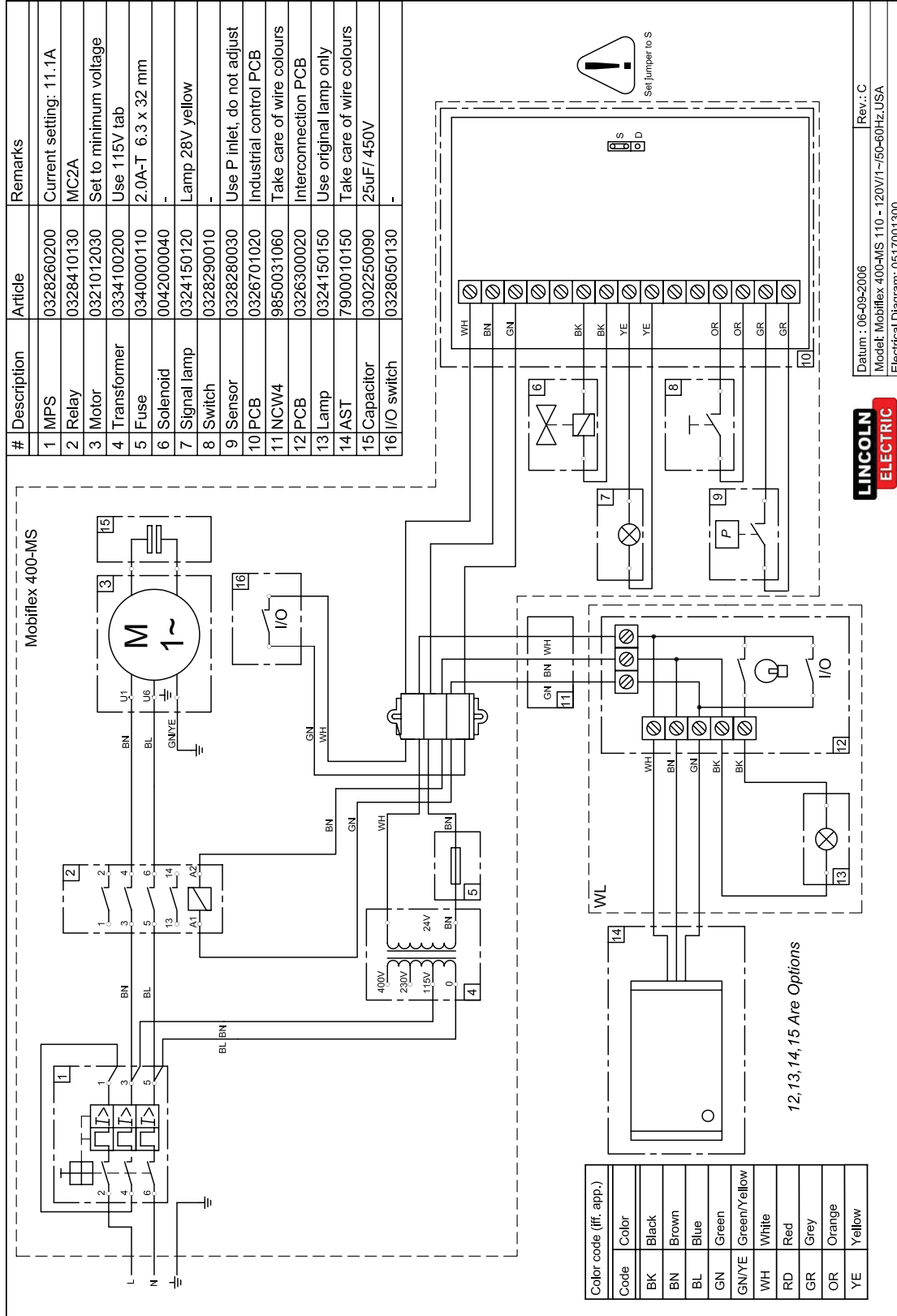

#	Description	Article	Remarks
1	MPS	0328260200	Current setting: 11.1A
2	Relay	0328410130	MC2A
3	Motor	0321012030	Set to minimum voltage
4	Transformer	0334100200	Use 115V tab
5	Fuse	0340000110	2.0A-T 6.3 x 32 mm
6	Solenoid	0042000040	-
7	Signal lamp	0324150120	Lamp 28V yellow
8	Switch	0328290010	-
9	Sensor	0328280030	Use P inlet, do not adjust
10	PCB	0326701020	Industrial control PCB
11	NCW4	9850031060	Take care of wire colours
12	PCB	0326300020	Interconnection PCB
13	Lamp	0324150150	Use original lamp only
14	AST	7900010150	Take care of wire colours
15	Capacitor	0302250090	25uF/450V
16	I/O switch	0328050130	-

Code	Color
BK	Black
BN	Brown
BL	Blue
GN	Green
GN/YE	Green/Yellow
WH	White
RD	Red
GR	Grey
OR	Orange
YE	Yellow

12, 13, 14, 15 Are Options

Datum : 06-09-2006
 Model: Mobiflex 400-MS 110 - 120V/1~/50-60Hz USA
 Electrical Diagram: 0517001300
 Rev.: C



NOTE: This diagram is for reference only. It may not be accurate for all machines covered by this manual. The specific diagram for a particular code is pasted inside the machine on one of the enclosure panels. If the diagram is illegible, write to the Service Department for a replacement. Give the equipment code number.