



## **NA-5**

### **AUTOMATIC WELDING SYSTEMS**

For use with machines having Code Numbers: **NA-5N**  
**NA-5NF**  
**NA-5S**  
**NA-5SF**

# **SERVICE MANUAL**

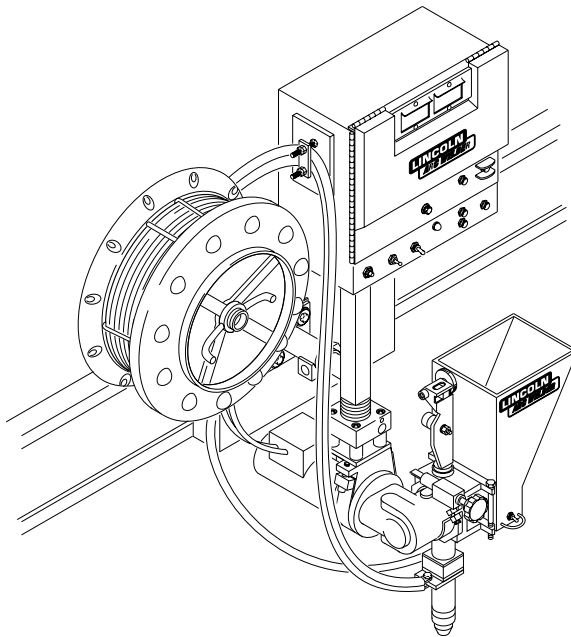

## ⚠️ WARNING

### ⚠️ CALIFORNIA PROPOSITION 65 WARNINGS ⚠️

Diesel engine exhaust and some of its constituents are known to the State of California to cause cancer, birth defects, and other reproductive harm.

The Above For Diesel Engines

The engine exhaust from this product contains chemicals known to the State of California to cause cancer, birth defects, or other reproductive harm.

The Above For Gasoline Engines

**ARC WELDING CAN BE HAZARDOUS. PROTECT YOURSELF AND OTHERS FROM POSSIBLE SERIOUS INJURY OR DEATH. KEEP CHILDREN AWAY. PACEMAKER WEARERS SHOULD CONSULT WITH THEIR DOCTOR BEFORE OPERATING.**

Read and understand the following safety highlights. For additional safety information, it is strongly recommended that you purchase a copy of "Safety in Welding & Cutting - ANSI Standard Z49.1" from the American Welding Society, P.O. Box 351040, Miami, Florida 33135 or CSA Standard W117.2-1974. A Free copy of "Arc Welding Safety" booklet E205 is available from the Lincoln Electric Company, 22801 St. Clair Avenue, Cleveland, Ohio 44117-1199.

**BE SURE THAT ALL INSTALLATION, OPERATION, MAINTENANCE AND REPAIR PROCEDURES ARE PERFORMED ONLY BY QUALIFIED INDIVIDUALS.**



### FOR ENGINE powered equipment.

1.a. Turn the engine off before troubleshooting and maintenance work unless the maintenance work requires it to be running.



1.b. Operate engines in open, well-ventilated areas or vent the engine exhaust fumes outdoors.



1.c. Do not add the fuel near an open flame welding arc or when the engine is running. Stop the engine and allow it to cool before refueling to prevent spilled fuel from vaporizing on contact with hot engine parts and igniting. Do not spill fuel when filling tank. If fuel is spilled, wipe it up and do not start engine until fumes have been eliminated.



1.d. Keep all equipment safety guards, covers and devices in position and in good repair. Keep hands, hair, clothing and tools away from V-belts, gears, fans and all other moving parts when starting, operating or repairing equipment.

1.e. In some cases it may be necessary to remove safety guards to perform required maintenance. Remove guards only when necessary and replace them when the maintenance requiring their removal is complete. Always use the greatest care when working near moving parts.

1.f. Do not put your hands near the engine fan. Do not attempt to override the governor or idler by pushing on the throttle control rods while the engine is running.

1.g. To prevent accidentally starting gasoline engines while turning the engine or welding generator during maintenance work, disconnect the spark plug wires, distributor cap or magneto wire as appropriate.

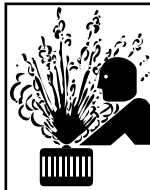

1.h. To avoid scalding, do not remove the radiator pressure cap when the engine is hot.



### ELECTRIC AND MAGNETIC FIELDS may be dangerous

2.a. Electric current flowing through any conductor causes localized Electric and Magnetic Fields (EMF). Welding current creates EMF fields around welding cables and welding machines

2.b. EMF fields may interfere with some pacemakers, and welders having a pacemaker should consult their physician before welding.

2.c. Exposure to EMF fields in welding may have other health effects which are now not known.

2.d. All welders should use the following procedures in order to minimize exposure to EMF fields from the welding circuit:

2.d.1. Route the electrode and work cables together - Secure them with tape when possible.

2.d.2. Never coil the electrode lead around your body.

2.d.3. Do not place your body between the electrode and work cables. If the electrode cable is on your right side, the work cable should also be on your right side.

2.d.4. Connect the work cable to the workpiece as close as possible to the area being welded.

2.d.5. Do not work next to welding power source.

Mar '95



### ELECTRIC SHOCK can kill.

- 3.a. The electrode and work (or ground) circuits are electrically “hot” when the welder is on. Do not touch these “hot” parts with your bare skin or wet clothing. Wear dry, hole-free gloves to insulate hands.
- 3.b. Insulate yourself from work and ground using dry insulation. Make certain the insulation is large enough to cover your full area of physical contact with work and ground.
- In addition to the normal safety precautions, if welding must be performed under electrically hazardous conditions (in damp locations or while wearing wet clothing; on metal structures such as floors, gratings or scaffolds; when in cramped positions such as sitting, kneeling or lying, if there is a high risk of unavoidable or accidental contact with the workpiece or ground) use the following equipment:**
- Semiautomatic DC Constant Voltage (Wire) Welder.
  - DC Manual (Stick) Welder.
  - AC Welder with Reduced Voltage Control.
- 3.c. In semiautomatic or automatic wire welding, the electrode, electrode reel, welding head, nozzle or semiautomatic welding gun are also electrically “hot”.
- 3.d. Always be sure the work cable makes a good electrical connection with the metal being welded. The connection should be as close as possible to the area being welded.
- 3.e. Ground the work or metal to be welded to a good electrical (earth) ground.
- 3.f. Maintain the electrode holder, work clamp, welding cable and welding machine in good, safe operating condition. Replace damaged insulation.
- 3.g. Never dip the electrode in water for cooling.
- 3.h. Never simultaneously touch electrically “hot” parts of electrode holders connected to two welders because voltage between the two can be the total of the open circuit voltage of both welders.
- 3.i. When working above floor level, use a safety belt to protect yourself from a fall should you get a shock.
- 3.j. Also see Items 6.c. and 8.



### ARC RAYS can burn.

- 4.a. Use a shield with the proper filter and cover plates to protect your eyes from sparks and the rays of the arc when welding or observing open arc welding. Headshield and filter lens should conform to ANSI Z87.1 standards.
- 4.b. Use suitable clothing made from durable flame-resistant material to protect your skin and that of your helpers from the arc rays.
- 4.c. Protect other nearby personnel with suitable, non-flammable screening and/or warn them not to watch the arc nor expose themselves to the arc rays or to hot spatter or metal.



### FUMES AND GASES can be dangerous.

- 5.a. Welding may produce fumes and gases hazardous to health. Avoid breathing these fumes and gases. When welding, keep your head out of the fume. Use enough ventilation and/or exhaust at the arc to keep fumes and gases away from the breathing zone. **When welding with electrodes which require special ventilation such as stainless or hard facing (see instructions on container or MSDS) or on lead or cadmium plated steel and other metals or coatings which produce highly toxic fumes, keep exposure as low as possible and below Threshold Limit Values (TLV) using local exhaust or mechanical ventilation. In confined spaces or in some circumstances, outdoors, a respirator may be required. Additional precautions are also required when welding on galvanized steel.**
- 5.b. Do not weld in locations near chlorinated hydrocarbon vapors coming from degreasing, cleaning or spraying operations. The heat and rays of the arc can react with solvent vapors to form phosgene, a highly toxic gas, and other irritating products.
- 5.c. Shielding gases used for arc welding can displace air and cause injury or death. Always use enough ventilation, especially in confined areas, to insure breathing air is safe.
- 5.d. Read and understand the manufacturer’s instructions for this equipment and the consumables to be used, including the material safety data sheet (MSDS) and follow your employer’s safety practices. MSDS forms are available from your welding distributor or from the manufacturer.
- 5.e. Also see item 1.b.

Mar '95

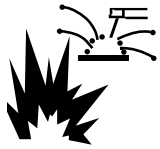

## WELDING SPARKS can cause fire or explosion.

6.a. Remove fire hazards from the welding area.

If this is not possible, cover them to prevent the welding sparks from starting a fire.

Remember that welding sparks and hot materials from welding can easily go through small cracks and openings to adjacent areas. Avoid welding near hydraulic lines. Have a fire extinguisher readily available.

- 6.b. Where compressed gases are to be used at the job site, special precautions should be used to prevent hazardous situations. Refer to "Safety in Welding and Cutting" (ANSI Standard Z49.1) and the operating information for the equipment being used.
- 6.c. When not welding, make certain no part of the electrode circuit is touching the work or ground. Accidental contact can cause overheating and create a fire hazard.
- 6.d. Do not heat, cut or weld tanks, drums or containers until the proper steps have been taken to insure that such procedures will not cause flammable or toxic vapors from substances inside. They can cause an explosion even though they have been "cleaned". For information, purchase "Recommended Safe Practices for the Preparation for Welding and Cutting of Containers and Piping That Have Held Hazardous Substances", AWS F4.1 from the American Welding Society (see address above).
- 6.e. Vent hollow castings or containers before heating, cutting or welding. They may explode.
- 6.f. Sparks and spatter are thrown from the welding arc. Wear oil free protective garments such as leather gloves, heavy shirt, cuffless trousers, high shoes and a cap over your hair. Wear ear plugs when welding out of position or in confined places. Always wear safety glasses with side shields when in a welding area.
- 6.g. Connect the work cable to the work as close to the welding area as practical. Work cables connected to the building framework or other locations away from the welding area increase the possibility of the welding current passing through lifting chains, crane cables or other alternate circuits. This can create fire hazards or overheat lifting chains or cables until they fail.
- 6.h. Also see item 1.c.

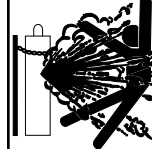

## CYLINDER may explode if damaged.

7.a. Use only compressed gas cylinders containing the correct shielding gas for the process used and properly operating regulators designed for the gas and pressure used. All hoses, fittings, etc. should be suitable for the application and maintained in good condition.

- 7.b. Always keep cylinders in an upright position securely chained to an undercarriage or fixed support.
- 7.c. Cylinders should be located:
  - Away from areas where they may be struck or subjected to physical damage.
  - A safe distance from arc welding or cutting operations and any other source of heat, sparks, or flame.
- 7.d. Never allow the electrode, electrode holder or any other electrically "hot" parts to touch a cylinder.
- 7.e. Keep your head and face away from the cylinder valve outlet when opening the cylinder valve.
- 7.f. Valve protection caps should always be in place and hand tight except when the cylinder is in use or connected for use.
- 7.g. Read and follow the instructions on compressed gas cylinders, associated equipment, and CGA publication P-1, "Precautions for Safe Handling of Compressed Gases in Cylinders," available from the Compressed Gas Association 1235 Jefferson Davis Highway, Arlington, VA 22202.



## FOR ELECTRICALLY powered equipment.

- 8.a. Turn off input power using the disconnect switch at the fuse box before working on the equipment.
- 8.b. Install equipment in accordance with the U.S. National Electrical Code, all local codes and the manufacturer's recommendations.
- 8.c. Ground the equipment in accordance with the U.S. National Electrical Code and the manufacturer's recommendations.

## PRÉCAUTIONS DE SÛRETÉ

Pour votre propre protection lire et observer toutes les instructions et les précautions de sûreté spécifiques qui paraissent dans ce manuel aussi bien que les précautions de sûreté générales suivantes:

### Sûreté Pour Soudage A L'Arc

1. Protégez-vous contre la secousse électrique:
  - a. Les circuits à l'électrode et à la pièce sont sous tension quand la machine à souder est en marche. Eviter toujours tout contact entre les parties sous tension et la peau nue ou les vêtements mouillés. Porter des gants secs et sans trous pour isoler les mains.
  - b. Faire très attention de bien s'isoler de la masse quand on soude dans des endroits humides, ou sur un plancher métallique ou des grilles métalliques, principalement dans les positions assis ou couché pour lesquelles une grande partie du corps peut être en contact avec la masse.
  - c. Maintenir le porte-électrode, la pince de masse, le câble de soudage et la machine à souder en bon et sûr état de fonctionnement.
  - d. Ne jamais plonger le porte-électrode dans l'eau pour le refroidir.
  - e. Ne jamais toucher simultanément les parties sous tension des porte-électrodes connectés à deux machines à souder parce que la tension entre les deux pinces peut être le total de la tension à vide des deux machines.
  - f. Si on utilise la machine à souder comme une source de courant pour soudage semi-automatique, ces précautions pour le porte-électrode s'appliquent aussi au pistolet de soudage.
2. Dans le cas de travail au dessus du niveau du sol, se protéger contre les chutes dans le cas où on recoit un choc. Ne jamais enrouler le câble-électrode autour de n'importe quelle partie du corps.
3. Un coup d'arc peut être plus sévère qu'un coup de soleil, donc:
  - a. Utiliser un bon masque avec un verre filtrant approprié ainsi qu'un verre blanc afin de se protéger les yeux du rayonnement de l'arc et des projections quand on soude ou quand on regarde l'arc.
  - b. Porter des vêtements convenables afin de protéger la peau de soudeur et des aides contre le rayonnement de l'arc.
  - c. Protéger l'autre personnel travaillant à proximité au soudage à l'aide d'écrans appropriés et non-inflammables.
4. Des gouttes de laitier en fusion sont émises de l'arc de soudage. Se protéger avec des vêtements de protection libres de l'huile, tels que les gants en cuir, chemise épaisse, pantalons sans revers, et chaussures montantes.

5. Toujours porter des lunettes de sécurité dans la zone de soudage. Utiliser des lunettes avec écrans latéraux dans les zones où l'on pique le laitier.
6. Eloigner les matériaux inflammables ou les recouvrir afin de prévenir tout risque d'incendie dû aux étincelles.
7. Quand on ne soude pas, poser la pince à un endroit isolé de la masse. Un court-circuit accidentel peut provoquer un échauffement et un risque d'incendie.
8. S'assurer que la masse est connectée le plus près possible de la zone de travail qu'il est pratique de le faire. Si on place la masse sur la charpente de la construction ou d'autres endroits éloignés de la zone de travail, on augmente le risque de voir passer le courant de soudage par les chaînes de levage, câbles de grue, ou autres circuits. Cela peut provoquer des risques d'incendie ou d'échauffement des chaînes et des câbles jusqu'à ce qu'ils se rompent.
9. Assurer une ventilation suffisante dans la zone de soudage. Ceci est particulièrement important pour le soudage de tôles galvanisées plombées, ou cadmiées ou tout autre métal qui produit des fumées toxiques.
10. Ne pas souder en présence de vapeurs de chlore provenant d'opérations de dégraissage, nettoyage ou pistelage. La chaleur ou les rayons de l'arc peuvent réagir avec les vapeurs du solvant pour produire du phosgène (gas fortement toxique) ou autres produits irritants.
11. Pour obtenir de plus amples renseignements sur la sûreté, voir le code "Code for safety in welding and cutting" CSA Standard W 117.2-1974.

## PRÉCAUTIONS DE SÛRETÉ POUR LES MACHINES À SOUDER À TRANSFORMATEUR ET À REDRESSEUR

1. Relier à la terre le chassis du poste conformément au code de l'électricité et aux recommandations du fabricant. Le dispositif de montage ou la pièce à souder doit être branché à une bonne mise à la terre.
2. Autant que possible, l'installation et l'entretien du poste seront effectués par un électricien qualifié.
3. Avant de faire des travaux à l'intérieur de poste, la débrancher à l'interrupteur à la boîte de fusibles.
4. Garder tous les couvercles et dispositifs de sûreté à leur place.

Mar. '93

## MASTER TABLE OF CONTENTS FOR ALL SECTIONS

	<b>Page</b>
<b>Safety</b> .....	<b>i-iv</b>
<hr/>	
<b>Installation</b> .....	<b>Section A</b>
Technical Specifications .....	A-2
Mechanical Installation .....	A-4
Electrical Installation .....	A-6
Electrode Polarity .....	A-8
Power Source Connection Diagrams .....	A-8
<hr/>	
<b>Operating Instructions</b> .....	<b>Section B</b>
Safety Precautions .....	B-2
Operator's Instructions .....	B-2
Controls and Their Functions .....	B-3
Setup Instructions .....	B-4
Starting and Stopping Sequences .....	B-5
Setting Travel Starting and Stopping .....	B-6
Voltage Control Response .....	B-9
Automatic Shutdown .....	B-10
Cold Start Circuitry .....	B-11
Security of Weld Procedure Settings .....	B-12
<hr/>	
<b>Accessories</b> .....	<b>Section C</b>
General .....	C-2
Listing of Accessories .....	C-3
<hr/>	
<b>Maintenance</b> .....	<b>Section D</b>
Control Box .....	D-2
Welding Head .....	D-3
Optional Features .....	D-6
<hr/>	
<b>Theory of Operation</b> .....	<b>Section E</b>
General Description .....	E-2
Input Power Circuits .....	E-2
Power and Voltage Boards .....	E-3
Control, Logic and Procedure Boards .....	E-4
Optional start, Crater Fill and Weld Timer Boards .....	E-5
SCR Operation .....	E-6
<hr/>	
<b>Troubleshooting</b> .....	<b>Section F</b>
<hr/>	
<b>Electrical Diagrams</b> .....	<b>Section G</b>
<hr/>	
<b>Parts Listing</b> .....	<b>P-135</b>
<hr/>	



# TABLE OF CONTENTS

## - INSTALLATION SECTION -

---

<b>Installation</b> .....	<b>Section A</b>
Technical Specifications .....	A-2
Mechanical Installation .....	A-4
Introduction .....	A-4
Control Box Installation .....	A-4
Welding Head Installation .....	A-5
Electrical Installation .....	A-6
Input Power Requirements .....	A-6
Control Box to Welding Head Connections .....	A-6
Power Supply to Control Box Connections .....	A-7
Electrode Polarity .....	A-8
Power Source Connection Diagrams .....	A-8
Figure A.8 — Connection of NA-5 (All) to a DC-600 .....	A-9
Figure A.9 — Connection of NA-5 (All) to a DC-650 Pro .....	A-10
Figure A.10 — Connection of NA-5 (All) to a R3S-400, -600 or -800 with no Line Voltage Compensator (Obsolete) .....	A-11
Figure A.11 — Connection of NA-5 (All) to a SAM-400 Motor Generator or Engine Welder .....	A-12
Figure A.12 — Connection of NA-5 (All) to a SAM-650 Engine Welder .....	A-13
Figure A.13 — Connection of NA-5 to DC-1000 or DC-1500 .....	A-14
Figure A.14 — Connection of NA-5 to DC-400 or CV-400 .....	A-15



## TECHNICAL SPECIFICATIONS – NA-5

MINIMUM ELECTRICAL INPUT REQUIREMENTS				
115 VAC @ 3 amps 50/60 Hz power				
REQUIRED WELDING POWER SOURCE				
NA-5		DC Constant Voltage		
WIRE FEED SPEED and GEAR RATIOS				
GEAR RATIO	FEED SPEED RANGE in./min (m/min)	MAX. WIRE SIZE in. (mm)		
		CORED WIRE	SOLID WIRE	
21:1	100 - 2070 (2.54 - 52.6)	0.052 (1.3)	0.052 (1.3)	
57:1	38 - 7.78 (0.96 - 19.8)	3/32 (2.4)	1/16 (1.6)	
95:1	22 - 456 (0.56 - 11.6)	5/32 (4.0)	1/8 (3.2)	
142:1	15 - 300 (0.38 - 7.62)	5/32 (4.0)	7/32 (5.6)	
PHYSICAL DIMENSIONS				
MODEL	LENGTH in. (mm)	WIDTH in. (mm)	HEIGHT in. (mm)	WEIGHT lbs (kg)
NA-5 Control Box	9.02 (229)	17.87 (454)	15.05 (382)	30 (13)

NA-5



Return to Section TOC

Return to Section TOC

Return to Section TOC

Return to Section TOC

Return to Master TOC

Return to Master TOC

Return to Master TOC

Return to Master TOC

FIGURE A.1 – BASIC CONTROL AND WIRE DRIVE SYSTEM.

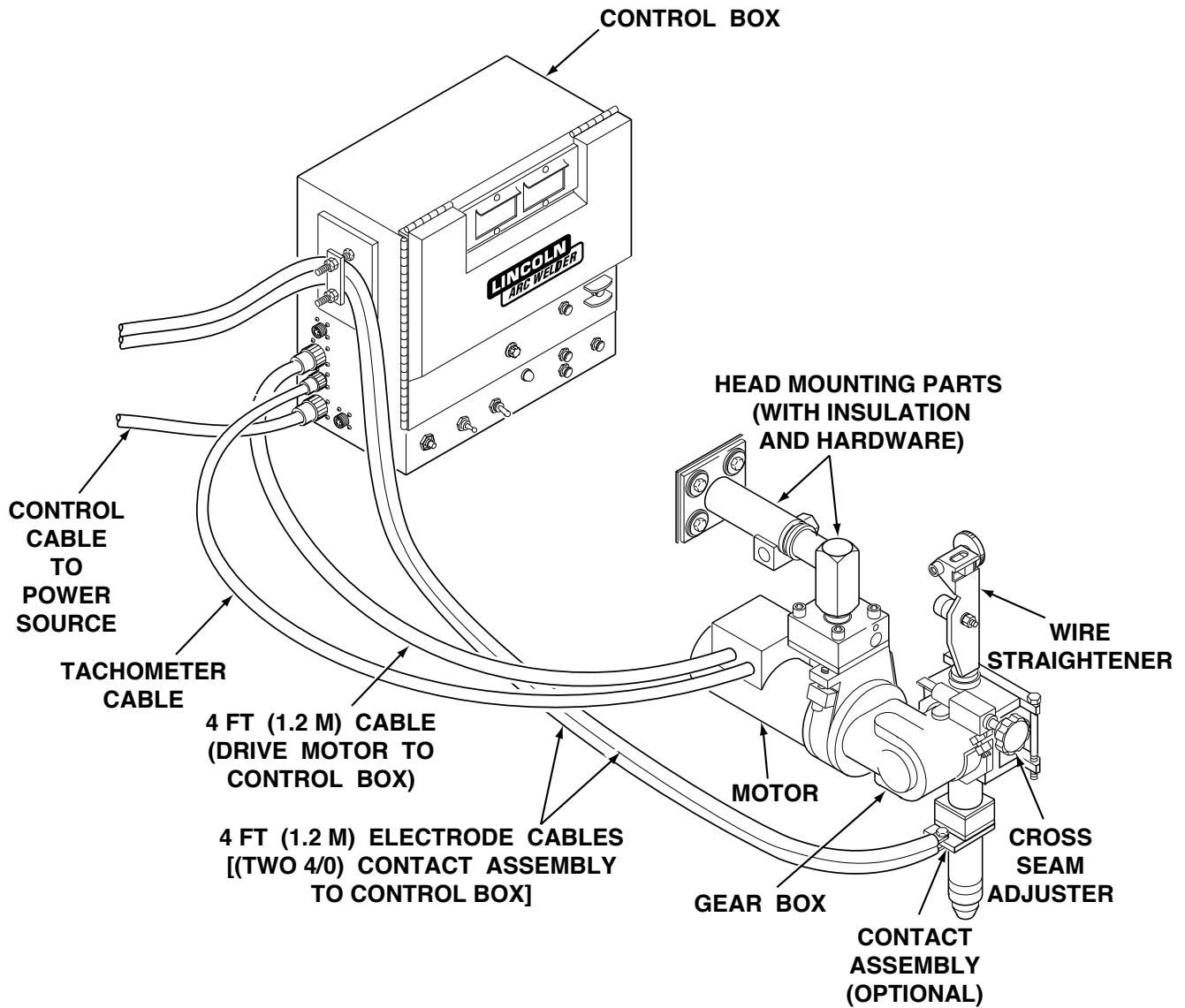

Return to Section TOC  
Return to Section TOC  
Return to Section TOC  
Return to Section TOC  
Return to Section TOC  
Return to Master TOC  
Return to Master TOC  
Return to Master TOC  
Return to Master TOC

## MECHANICAL INSTALLATION

### ⚠ WARNING



#### ELECTRIC SHOCK can kill.

- Turn off input power to the welding power source using the disconnect switch before working on this equipment.

## INTRODUCTION

This section covers the basic requirements to install the control box and welding head shown in **Figure A.1**. This section will give you mounting hole alignments, component mounting clearances, and any special instructions or precautions that must be followed when installing the control box and mounting head.

## CONTROL BOX INSTALLATION

The control box can be mounted either on the standard travel carriage or on a separate fixture. It is electrically grounded by a lead in the input cable assembly.

To install the control box on the standard travel carriage, use mounting kit T14469 and perform the following steps. Also refer to Figure A.2.

1. Align the mounting holes in adapter plate M-13945 to the holes in the travel carriage.
2. Install four hex head screws through the adapter plate and into the travel carriage.
3. Secure the control box to the adapter plate with four lock washers and four bolts, two from the bottom and two from the back.

Before mounting the control box onto a fixture, you must provide mounting holes in the fixture per the measurements provided in **Figure A.3** or dimension print S16717. When placing the mounting holes, ensure the controls and meters are convenient to the operator.

**FIGURE A.2 – CONTROL BOX  
CARRIAGE MOUNTING.**

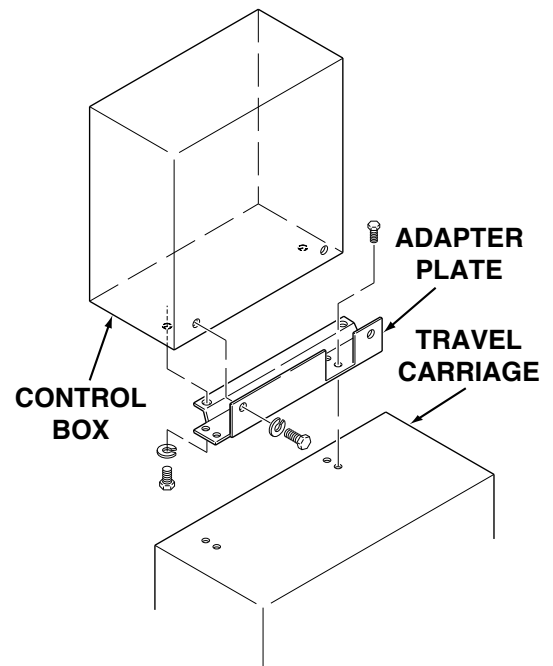

To install the control box on a fixture, perform the following steps and refer to Figure A.3.

1. Align the mounting holes on the back and/or bottom of the control box with the holes you put in the fixture according to the measurements provided in Figure A.3.
2. Secure the control box to the fixture using lock washers and hex head screws at each of the mounting holes.

**FIGURE A.3 – CONTROL BOX  
FIXTURE MOUNTING.**

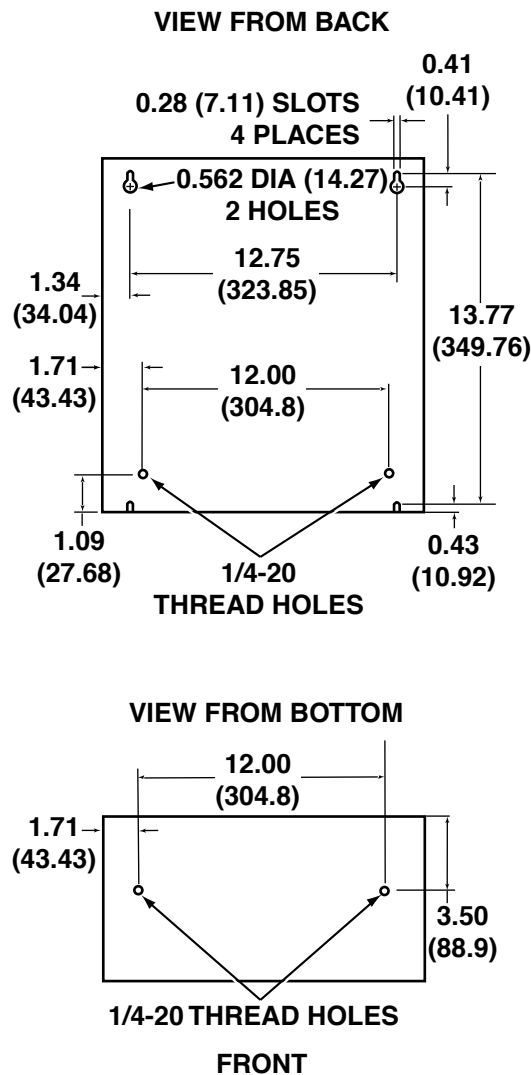

**NOTE: DIMENSIONS ARE IN INCHES  
WITH MILLIMETERS IN  
PARENTHESES.**

## WELDING HEAD INSTALLATION

The welding head can be mounted either with the standard head mounting hardware or with the horizontal head and/or vertical lift adjusters. Design the installation of your welding head so it meets the adjustability requirements of your welding application. Refer to **Section C**, Accessories, for more information regarding the adjustable mounting hardware.

The welding head and electrode are electrically “hot” when welding. **They must be insulated from ground.**

Standard head mounting hardware and insulation are shipped with the NA-5 welding head. If you are mounting the welding head on a separate fixture, provide the mounting holes for the standard head mount as specified in Figure A.4. For best arc striking, use a rigid mounting that prevents the head from moving when the electrode strikes the work.

**FIGURE A.4 – WELDING HEAD  
MOUNTING HOLES.**

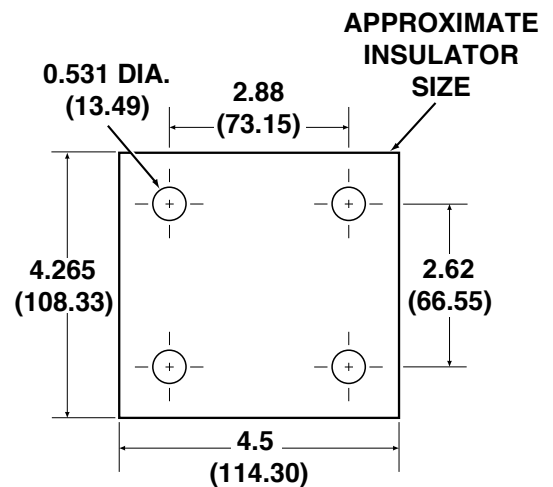

**NOTE: DIMENSIONS ARE IN INCHES  
WITH MILLIMETERS IN  
PARENTHESES.**

When mounting the welding head to the standard travel carriage, (see 305-B sec. T2.2.4) mount it so only a minimum of overhang weight exists. Mount the head so it stays within the dimension shown in Figure A.5.

**FIGURE A.5 – MOUNT TO CARRIAGE OVERHANG DIMENSION.**

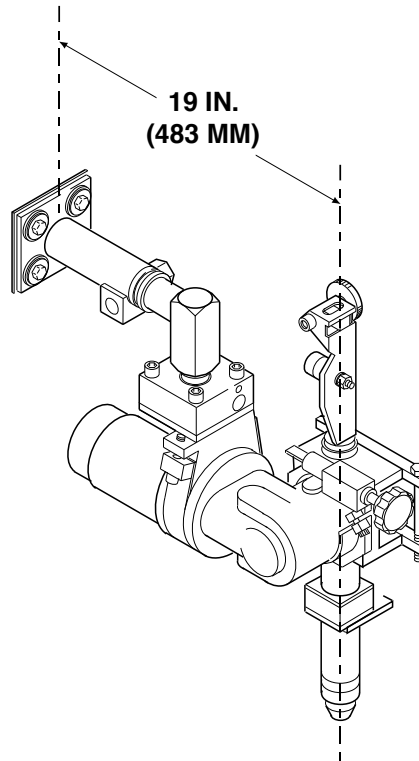

**ELECTRICAL INSTALLATION**

**⚠ WARNING**



**ELECTRIC SHOCK can kill.**

- Do not touch electrically live parts such as output terminals or internal wiring.

-----  
 This section provides information on proper wiring procedures for the NA-5 welding system. This section also provides basic con-

nection diagrams for connecting automatic welding systems to various welding power sources.

**INPUT POWER REQUIREMENTS**

350 volt-amperes of 115 VAC 50/60 Hz power is required for the wire feed motor and controls. Another 250 volt-amperes may be required depending on the travel circuit.

**CONTROL BOX TO WELDING HEAD CONNECTIONS**

All welding heads include a 4 ft (1.2 m) motor cable and motor tachometer cable. Insert the plugs on these cables into the matching receptacles on the side of the control box.

If the 4 ft (1.2 m) cables are not sufficient, install a K335 or K338 control to head extension cable of the length ordered [up to 30 ft (9.1 m)]. The K335, for the NA-5S head, includes motor, tachometer and flux hopper lead extensions with polarized plugs on each end, and electrode cables. The K338 for the NA-5N, NF, and SF heads is the same as the K335 without the flux hopper lead extension.

The NA-5N and NA-5S also include two 4 ft (1.2 m) lengths of electrode cable. Bolt the terminals at one end of the the cable pair to the wire contact assembly and the terminals at the other end to the electrode leads on the power source to control cable assembly. Properly insulate the bolted connection. When the K335 or K338 extension cables are used between the controls and heads, the 4 ft (1.2 m) lengths of electrode cable are not used. If currents or duty cycles higher than 1000 amps at 80% duty cycle will be used, add additional electrode cable per Table A.1.

**TABLE A.1**

	<b>80% Duty Cycle</b>
Below 1000 amps	Two 4/0
1000 to 1300 amps	Three 4/0
1300 to 1500 amps	Four 4/0

Return to Section TOC

Return to Section TOC

Return to Section TOC

Return to Section TOC

Return to Master TOC

Return to Master TOC

Return to Master TOC

Return to Master TOC

The “F” models do not include the 4 ft (1.2 m) lengths of electrode cable as standard. If you are not using a K335 or K338 extension cable for the NA-5NF or NA-5SF, order an appropriate length of the needed electrode cable. Connect it between the wire contact assembly and the control cable assembly as described above.

## POWER SUPPLY TO CONTROL BOX CONNECTIONS

At the NA-5 control box, in order to activate the NA-5 weld current sensing switch, the electrode cables of the control cable assembly must be placed under the clamp bar on the left-hand side of the control box, as shown in Figure A.6. This is required for proper operation of the reed switch. The nuts holding the clamp bar in place need only to be pulled up snug. Do not overtighten. If a carriage is used, the electrode cables should also be clamped to it with the cable clamp supplied on the carriage. Do not clamp the control cable under the travel carriage clamp but route it over its top.

**FIGURE A.6 – CONTROL BOX ELECTRICAL CONNECTIONS.**

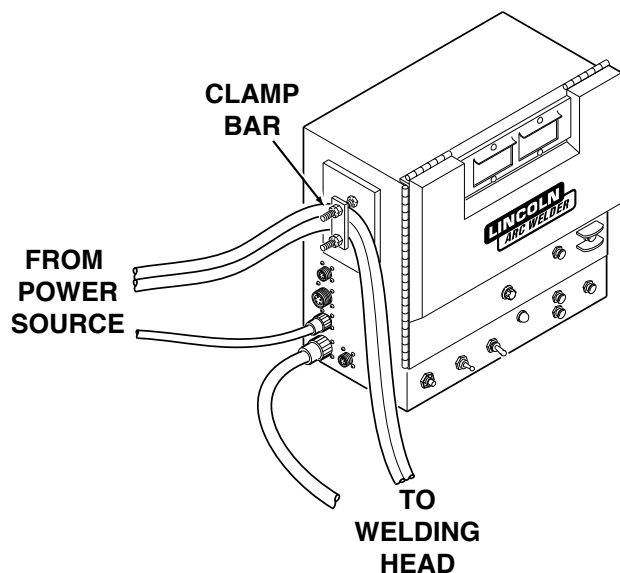

Insert the polarized connector of the K215 or K597\* control cable into the matching receptacle on the side of the control box.

With the power source off, connect the control cable assembly to the power source as follows:

1. If using the multi-process power source (SAM, SA-800, SAF-600, DC-400, DC-600, DC-1000, or DC-1500 types), be sure it is properly set for the welding process being used per the connection diagram (Figures **A.8** to **A.14**).
2. Connect the K215 control cable leads to the power source terminal strip exactly as specified on the connection diagram.\* Include all jumpers on the terminal strips as shown on the diagram. Do not put on any other jumpers. If currents or duty cycles higher than 1000 amps at 80% duty cycle will be used, add additional electrode cables to the K215 assembly per **Table A.1**.
3. Depending on the power source and the process to be used, the jumpers on the NA-5 voltage board may have to be changed. As shipped, the NA-5 is connected for use with the DC-400, DC-600, DC-1000, and DC-1500 type power sources. For other power sources, refer to the appropriate connection diagram and to IM305 Sec. T3.6.
4. Connect work leads of sufficient size and length per **Table A.1** between the “To Work” stud on the power source and the work. Be sure the connection to the work makes a tight and clean metal-to-metal contact.

*\*The K597 cable assembly has a 14-pin MS-type connector for use with later model Lincoln CV power sources.*

NA-5

**LINCOLN**  
ELECTRIC

## ELECTRODE POLARITY

### ⚠ WARNING



**ELECTRIC SHOCK  
can kill.**

- Turn off input power to the welding power source using the disconnect switch before working on this equipment.

Polarity is changed at the power source.

The polarity of the NA-5 control circuit is shipped connected for electrode positive. If electrode negative is required, two leads inside the NA-5 control must be reversed. Proceed as follows:

1. Turn off the input power to the NA-5 control box by turning off the welding power source.
2. Open the control box door and locate the terminal strips on the back of the control box in the lower left-hand corner as shown in Figure A.7.
3. On the right end of the lower terminal strip, interchange the black and white leads going to the terminals marked (+) and (-). The black lead (#67) must be connected to the same polarity as the electrode welding lead; i.e. if the electrode is positive, connect the black lead to the (+) terminal on the terminal strip. The white lead (#21) is connected to the opposite polarity terminal.

FIGURE A.7 – TERMINAL STRIP LOCATION.

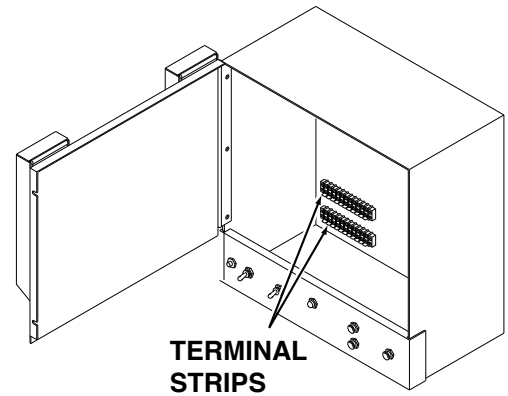

## POWER SOURCE CONNECTION DIAGRAMS

The following section contains the wiring diagrams necessary to connect the applicable power source to the control box. If there is no diagram, refer to power source manual.

### ⚠ WARNING



**ELECTRIC SHOCK  
can kill.**

- Turn off input power to the welding power source using the disconnect switch before working on this equipment.

NA-5

**LINCOLN**  
ELECTRIC



FIGURE A.8 – CONNECTION OF NA-5 (ALL) TO A DC-600.

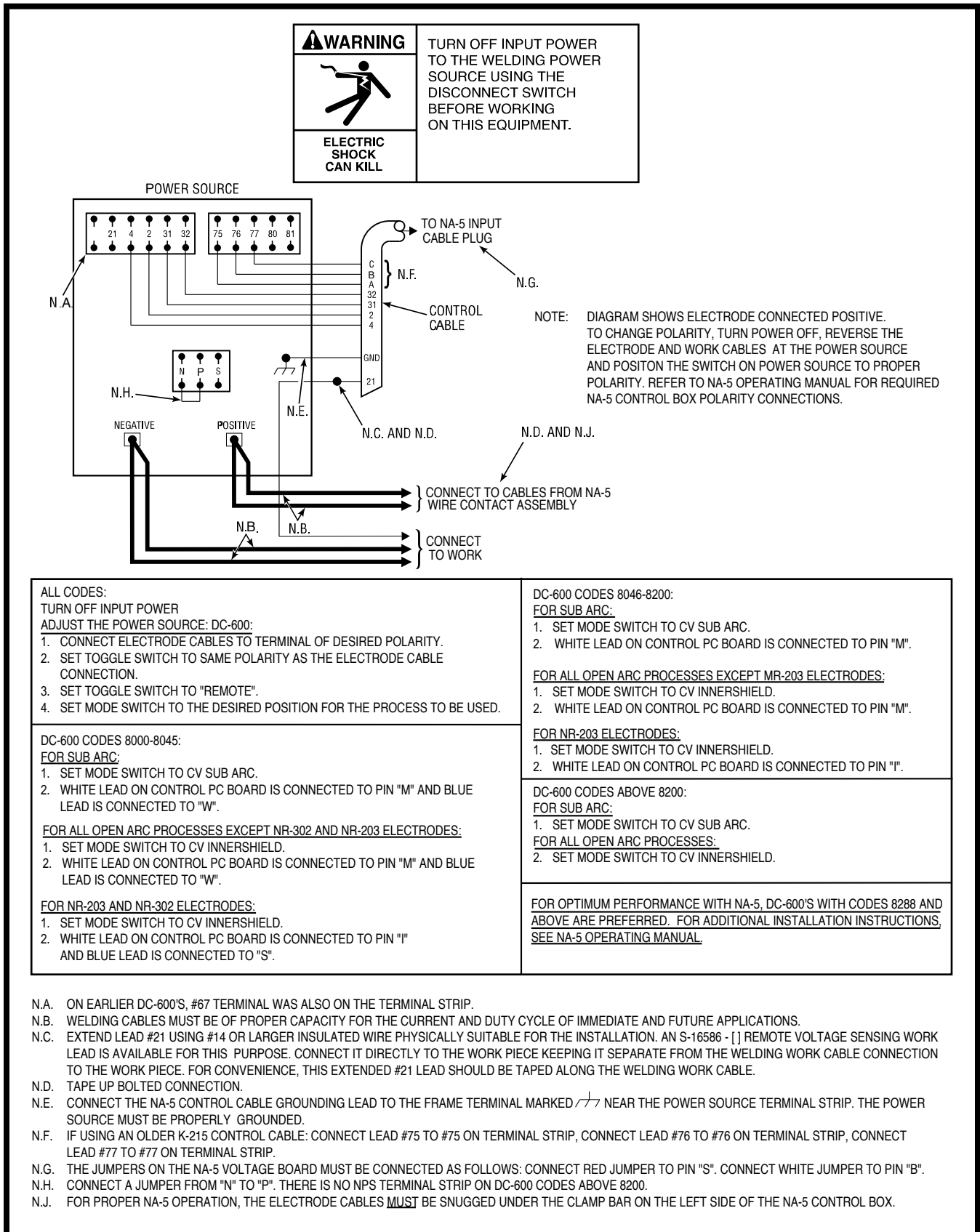

CLEVELAND, OHIO U.S.A.

NA-5



Return to Section TOC

Return to Section TOC

Return to Section TOC

Return to Section TOC

Return to Master TOC

Return to Master TOC

Return to Master TOC

Return to Master TOC



FIGURE A.9 – CONNECTION OF NA-5 (ALL) TO A DC-650 PRO

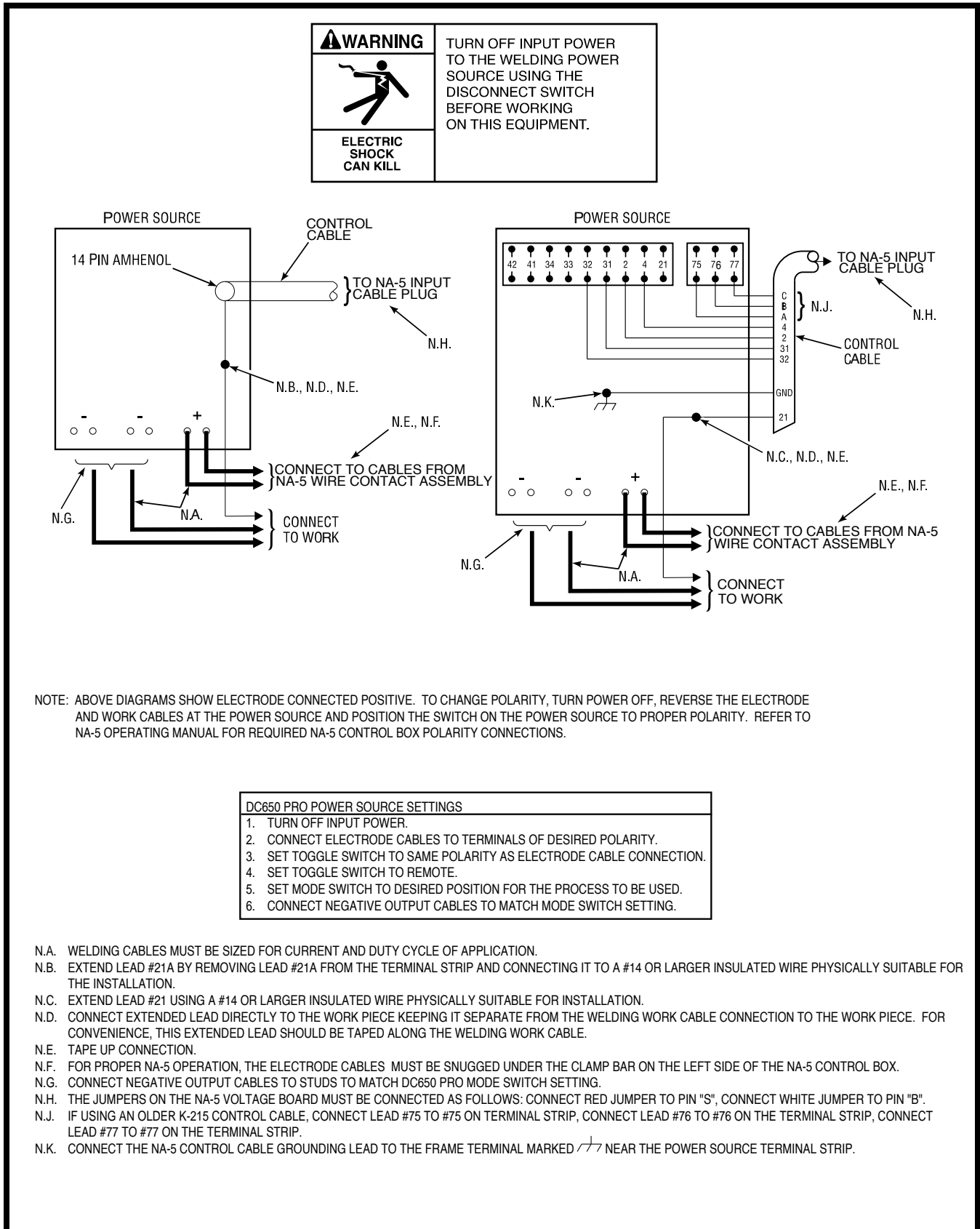
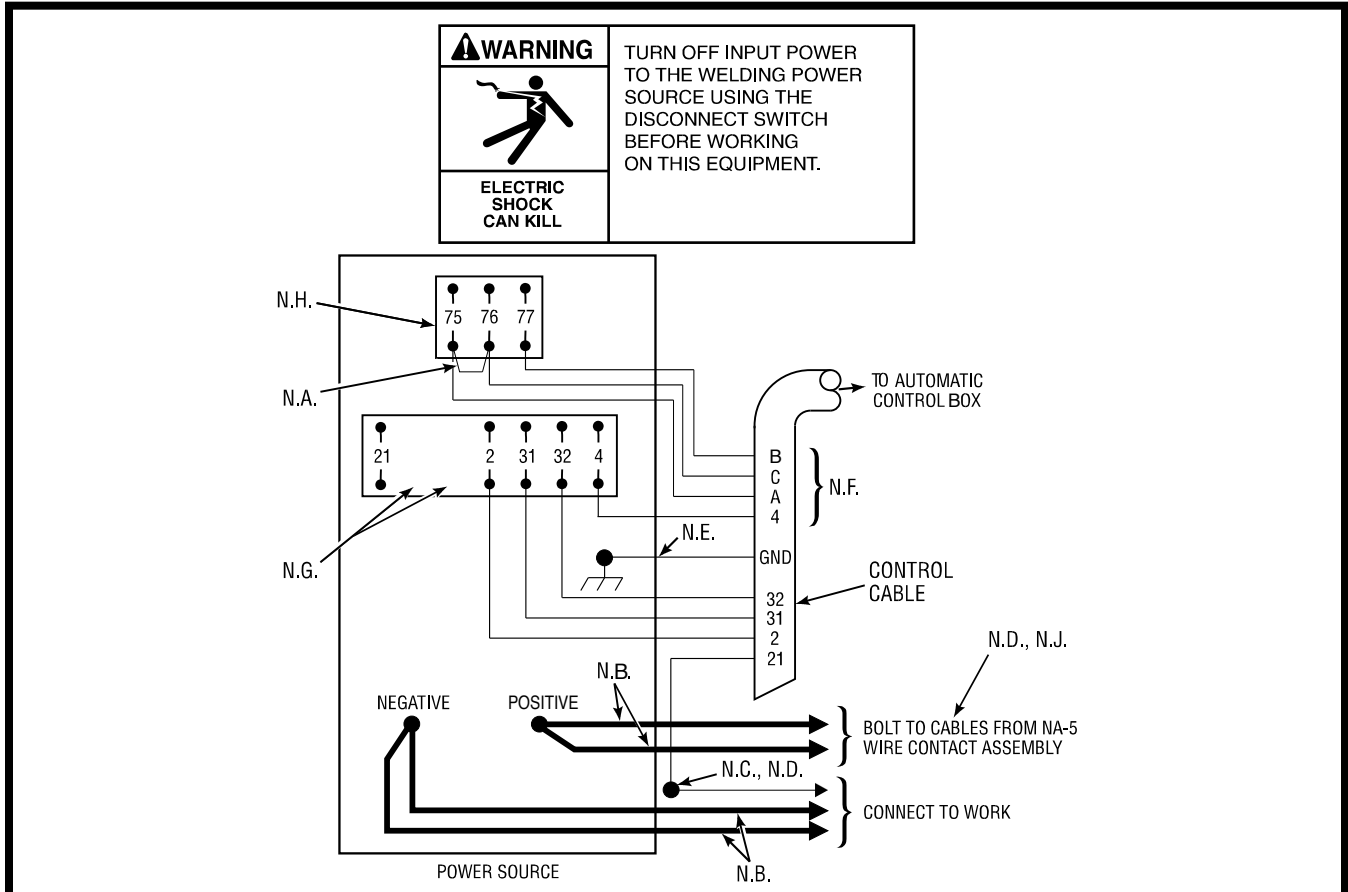

FIGURE A.10 – CONNECTION OF NA-5 (ALL) TO A R3S-400, -600, OR -800 WITH NO LINE VOLTAGE COMPENSATOR (OBSOLETE).



NOTE: ABOVE DIAGRAM SHOWS ELECTRODE CONNECTED POSITIVE. TO CHANGE POLARITY, TURN POWER OFF, REVERSE THE ELECTRODE AND WORK CABLES AT THE POWER SOURCE AND POSITION THE SWITCH ON POWER SOURCE TO PROPER POLARITY. REFER TO NA-5 OPERATING MANUAL FOR REQUIRED NA-5 CONTROL BOX POLARITY CONNECTIONS.

R3S POWER SOURCE SETTINGS	NA-5 SETTINGS
TURN POWER SOURCE OFF.	
<p><b>FOR ALL PROCESSES:</b></p> <ol style="list-style-type: none"> <li>CONNECT ELECTRODE CABLE TO TERMINAL OF DESIRED POLARITY.</li> <li>SET THE POLARITY SWITCH TO THE SAME POLARITY AS THE ELECTRODE CABLE CONNECTION.</li> <li>SET TOGGLE SWITCH TO REMOTE.</li> <li>INSTALL VOLTAGE TRIANGLE IN A POSITION AS CLOSE AS POSSIBLE TO THE DESIRED ARC VOLTAGE.</li> </ol>	<p><b>FOR SUB ARC:</b></p> <ol style="list-style-type: none"> <li>RED LEAD ON VOLTAGE PC BOARD IS CONNECTED TO PIN "S".</li> <li>WHITE LEAD ON VOLTAGE PC BOARD IS CONNECTED TO PIN "A".</li> </ol> <p><b>FOR ALL OPEN ARC PROCESSES:</b></p> <ol style="list-style-type: none"> <li>RED LEAD ON VOLTAGE PC BOARD IS CONNECTED TO PIN "F".</li> <li>WHITE LEAD ON VOLTAGE PC BOARD IS CONNECTED TO PIN "A".</li> </ol>

FOR ADDITIONAL INSTALLATION INSTRUCTIONS, SEE NA-5 OPERATING MANUAL.

- N.A. ADD JUMPER FROM #75 TO #76, USING INSULATED COPPER WIRE.
- N.B. WELDING CABLES MUST BE OF PROPER CAPACITY FOR THE CURRENT AND DUTY CYCLE OF IMMEDIATE AND FUTURE APPLICATIONS.
- N.C. EXTEND LEAD #21 USING #14 OR LARGER INSULATED WIRE PHYSICALLY SUITABLE FOR THE INSTALLATION. AN S-16586 [ ] REMOTE VOLTAGE-SENSING WORK LEAD IS AVAILABLE FOR THIS PURPOSE. CONNECT IT DIRECTLY TO THE WORK PIECE, KEEPING IT SEPARATE FROM THE WELDING WORK CABLE CONNECTION TO THE WORK PIECE. FOR CONVENIENCE, THIS EXTENDED #21 LEAD SHOULD BE TAPED ALONG THE WELDING WORK CABLE.
- N.D. TAPE UP BOLTED CONNECTION.
- N.E. CONNECT THE NA-5 CONTROL CABLE GROUNDING LEAD TO THE FRAME TERMINAL MARKED NEAR THE POWER SOURCE TERMINAL STRIP. THE POWER SOURCE MUST BE PROPERLY GROUNDED.
- N.F. IF USING AN OLDER K-215 CONTROL CABLE: CONNECT LEAD #75 TO #75 ON TERMINAL STRIP, CONNECT LEAD #76 TO #77 ON TERMINAL STRIP, CONNECT LEAD #77 TO #76 ON TERMINAL STRIP, AND ADD JUMPER PER N.A.
- N.G. ON EARLIER R3S MACHINES, #67 AND #1 TERMINALS WERE ALSO ON THE TERMINAL STRIP.
- N.H. THE UPPER TERMINAL STRIP (#75, #76, #77) WAS NOT PRESENT ON EARLY R3S MACHINES. THOSE MACHINES ARE NOT COMPATIBLE WITH THE NA-5 SINCE THERE CAN BE NO ADJUSTMENT OF VOLTAGE BY THE NA-5.
- N.J. FOR PROPER NA-5 OPERATION, THE ELECTRODE CABLES MUST BE SNUGGED UNDER THE CLAMP BAR ON THE LEFT SIDE OF THE NA-5 CONTROL BOX.



CLEVELAND, OHIO U.S.A.

NA-5



Return to Section TOC

Return to Section TOC

Return to Section TOC

Return to Section TOC



Return to Master TOC

Return to Master TOC

Return to Master TOC

Return to Master TOC

FIGURE A.11 – CONNECTION OF NA-5 (ALL) TO A SAM-400 MOTOR GENERATOR OR ENGINE WELDER.

 <p><b>WARNING</b></p>	<p>TURN OFF INPUT POWER TO THE WELDING POWER SOURCE USING THE DISCONNECT SWITCH BEFORE WORKING ON THIS EQUIPMENT.</p>
	
<p><b>ELECTRIC SHOCK CAN KILL</b></p>	

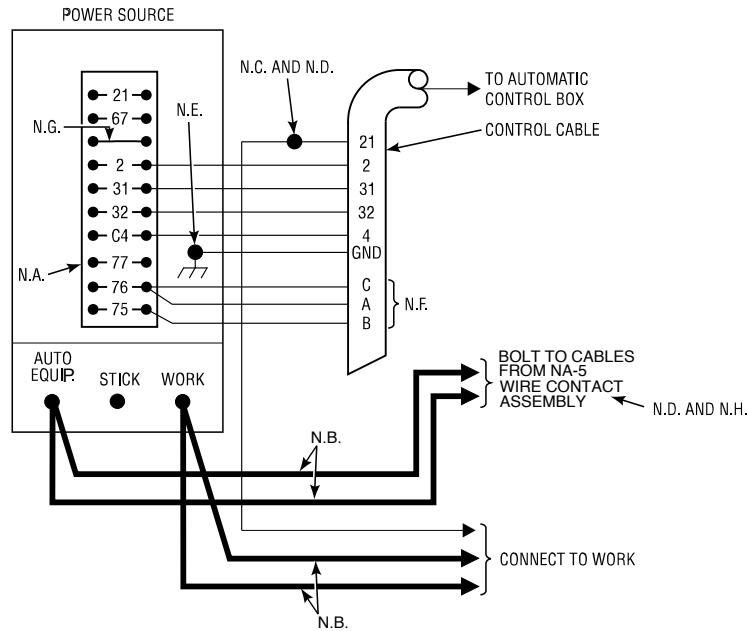

NOTE: TO CHANGE POLARITY, TURN POWER OFF, AND POSITION THE SWITCH ON POWER SOURCE TO PROPER POLARITY. REFER TO NA-5 OPERATING MANUAL FOR REQUIRED NA-5 CONTROL BOX POLARITY CONNECTIONS.

SAM POWER SOURCE SETTINGS	NA-5 SETTINGS
<p>TURN POWER SOURCE OFF.</p> <p><b>FOR SUB ARC:</b></p> <ol style="list-style-type: none"> <li>1. SET THE ELECTRODE POLARITY SWITCH TO THE VARIABLE VOLTAGE POSITION OF THE POLARITY DESIRED FOR THE PROCESS BEING USED.</li> <li>2. SET THE TOGGLE SWITCH TO CONSTANT VOLTAGE.</li> <li>3. SET THE CONSTANT VOLTAGE CONTROL TO NUMBER 7 AND THE CURRENT CONTROL TO 500.</li> </ol> <p><b>FOR ALL OPEN ARC PROCESSES:</b></p> <ol style="list-style-type: none"> <li>1. SET THE ELECTRODE POLARITY SWITCH TO THE CONSTANT VOLTAGE POSITION OF THE POLARITY DESIRED FOR THE PROCESS BEING USED.</li> <li>2. SET THE TOGGLE SWITCH TO CONSTANT VOLTAGE.</li> <li>3. SET THE CONSTANT VOLTAGE CONTROL TO NUMBER 5.</li> </ol>	<p><b>FOR SUB ARC:</b></p> <ol style="list-style-type: none"> <li>1. RED LEAD ON VOLTAGE PC BOARD IS CONNECTED TO PIN "S".</li> <li>2. WHITE LEAD ON VOLTAGE PC BOARD IS CONNECTED TO PIN "A".</li> </ol> <p><b>FOR ALL OPEN ARC PROCESSES:</b></p> <ol style="list-style-type: none"> <li>1. RED LEAD ON VOLTAGE PC BOARD IS CONNECTED TO PIN "F".</li> <li>2. WHITE LEAD ON VOLTAGE PC BOARD IS CONNECTED TO PIN "A".</li> </ol> <p>FOR ADDITIONAL INSTALLATION INSTRUCTIONS, SEE NA-5 OPERATING MANUAL.</p>

- N.A. REMOVE SAM PORTABLE FIELD CONTROL AND CONNECT NA-5 CONTROL CABLE.
- N.B. WELDING CABLES MUST BE OF PROPER CAPACITY FOR THE CURRENT AND DUTY CYCLE OF IMMEDIATE AND FUTURE APPLICATIONS.
- N.C. EXTEND LEAD #21 USING #14 OR LARGER INSULATED WIRE PHYSICALLY SUITABLE FOR THE INSTALLATION. AN S-16586-[ ] REMOTE VOLTAGE-SENSING WORK LEAD IS AVAILABLE FOR THIS PURPOSE. CONNECT IT DIRECTLY TO THE WORK PIECE, KEEPING IT SEPARATE FROM THE WELDING WORK CABLE CONNECTION TO WORK PIECE. FOR CONVENIENCE, THIS EXTENDED #21 LEAD SHOULD BE TAPED ALONG THE WELDING WORK CABLE.
- N.D. TAPE UP BOLTED CONNECTION.
- N.E. CONNECT THE NA-5 CONTROL CABLE GROUNDING LEAD TO THE FRAME TERMINAL MARKED , NEAR THE POWER SOURCE TERMINAL STRIP. THE POWER SOURCE MUST BE PROPERLY GROUNDED.
- N.F. IF USING AN OLDER K-215 CONTROL CABLE: CONNECT LEAD #76 TO #75 ON TERMINAL STRIP, CONNECT LEADS #75 AND #77 TO #76 ON TERMINAL STRIP.
- N.G. ON EARLIER SAM MACHINES, #1 TERMINAL WAS ALSO ON THE TERMINAL STRIP.
- N.H. FOR PROPER NA-5 OPERATION, THE ELECTRODE CABLES MUST BE SNUGGED UNDER THE CLAMP BAR ON THE LEFT SIDE OF THE NA-5 CONTROL BOX.



CLEVELAND, OHIO U.S.A.

NA-5



Return to Section TOC

FIGURE A.12 – CONNECTION OF NA-5 (ALL) TO A SAM-650 ENGINE WELDER.

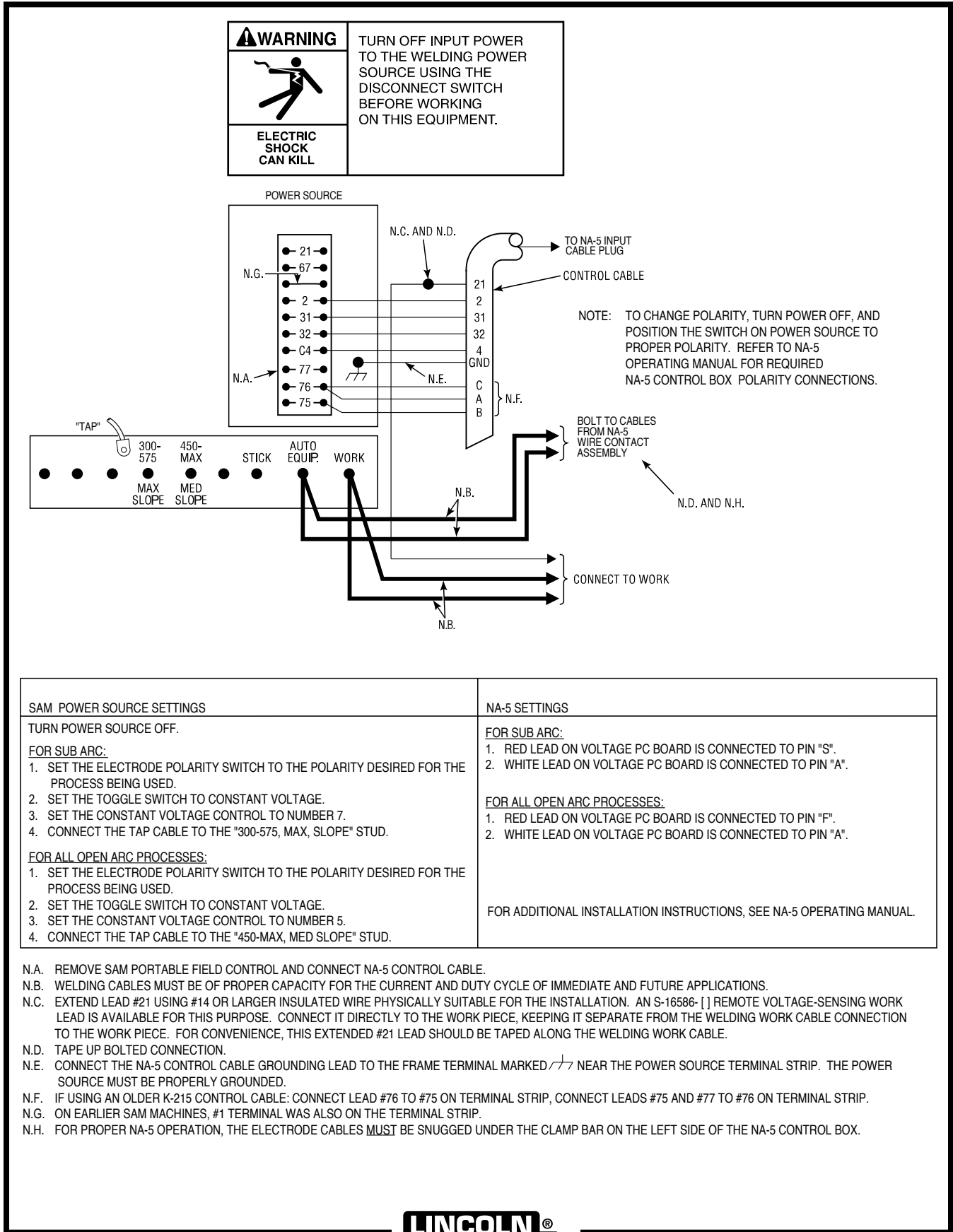

FIGURE A.13 – CONNECTION OF NA-5 TO DC-1000 OR DC-1500.

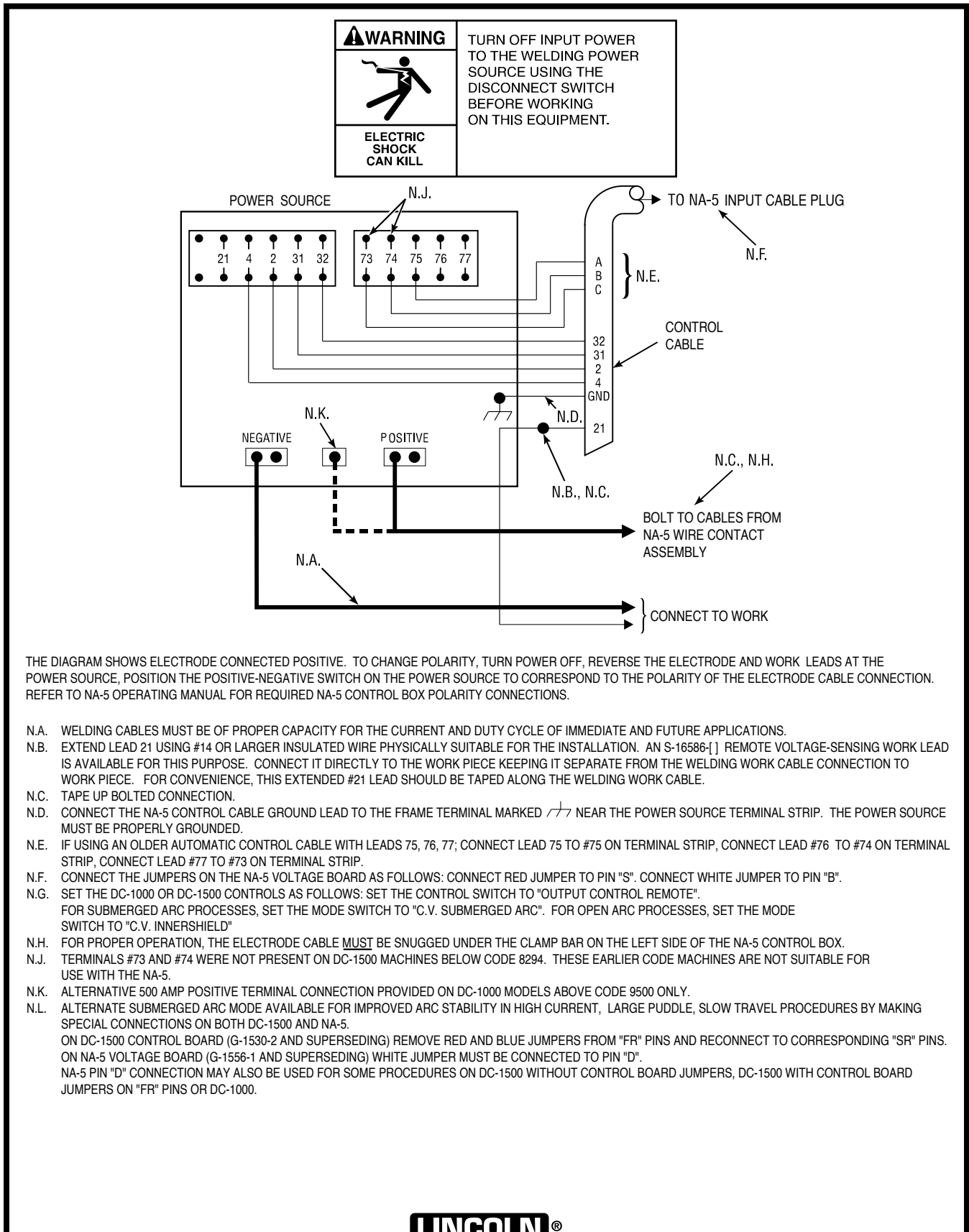
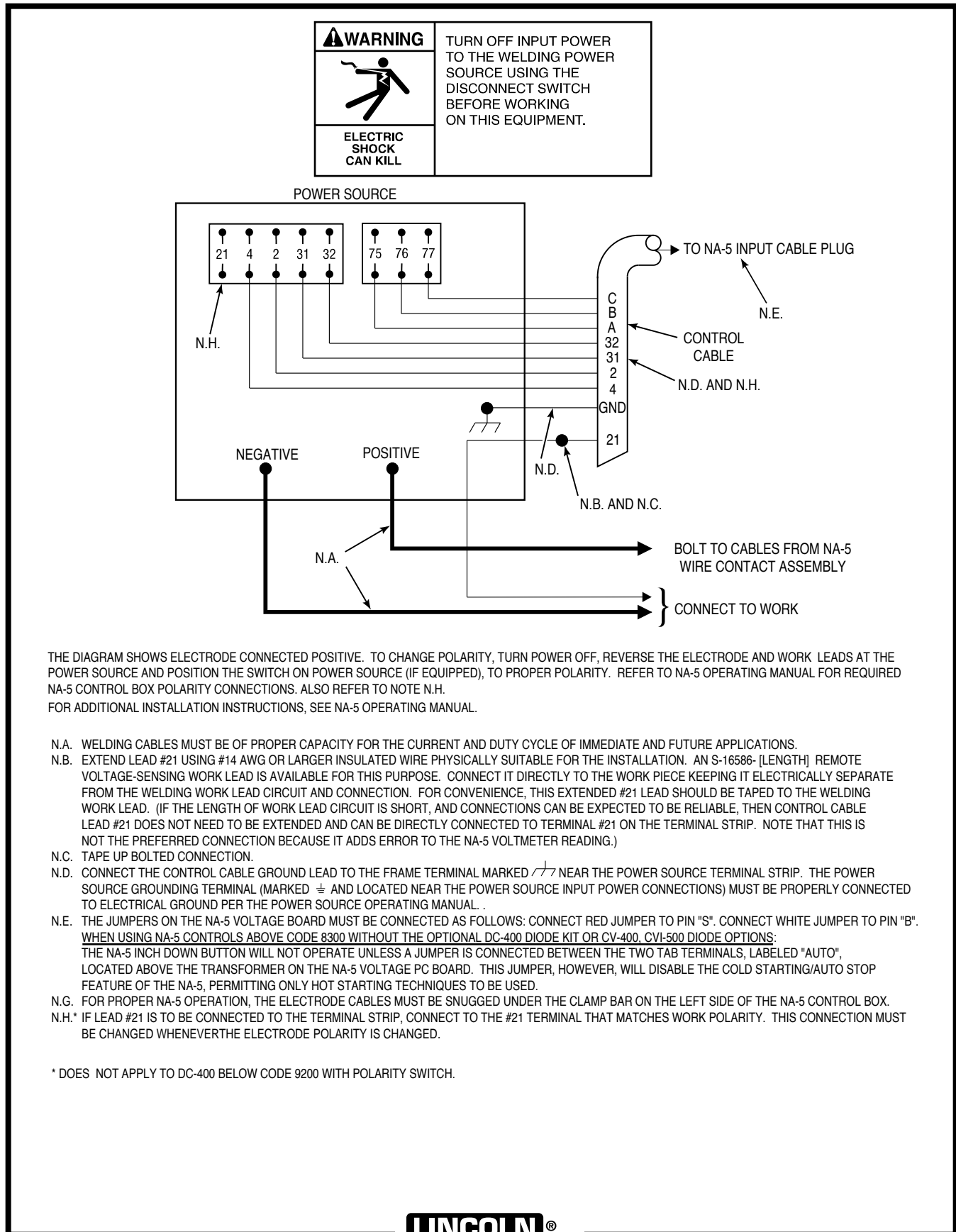

FIGURE A.14 – CONNECTION OF NA-5 TO DC-400 OR CV-400.



**LINCOLN**<sup>®</sup>  
**ELECTRIC**

CLEVELAND, OHIO U.S.A.

NA-5

**LINCOLN**<sup>®</sup>  
**ELECTRIC**

Return to Section TOC

Return to Section TOC

Return to Section TOC

Return to Section TOC

Return to Master TOC

Return to Master TOC

Return to Master TOC

Return to Master TOC

NA-5



# TABLE OF CONTENTS

## - OPERATING INSTRUCTIONS SECTION -

---

<b>Operating Instructions</b> .....	<b>Section B</b>
Safety Precautions .....	B-2
Operator's Instructions .....	B-2
Controls and Their Functions .....	B-3
Exposed Controls (With Lockable Cover Down) .....	B-3
Controls Under the Lockable Security Cover .....	B-3
Setup Instructions .....	B-4
Starting and Stopping Sequences .....	B-5
Means of Arc Striking .....	B-5
Setting Travel Starting and Stopping .....	B-6
Starting Sequences .....	B-6
Stopping Sequences .....	B-6
Reconfiguring the Travel Sequences .....	B-6
Voltage Control Response .....	B-9
Automatic Shutdown .....	B-10
Cold Start Circuitry .....	B-11
Security of Weld Procedure Settings .....	B-12

Return to Master TOC

Return to Master TOC

Return to Master TOC

Return to Master TOC



## SAFETY PRECAUTIONS

### ⚠ WARNING



#### ELECTRIC SHOCK can kill.

- Do not touch electrical-ly live parts or electrode with skin or wet clothing.
- Insulate yourself from work or ground.
- Always wear dry insulating gloves.



#### FUMES AND GASES can be dangerous.

- Keep your head out of fumes.
- Use ventilation or exhaust to remove fumes from breathing zone.

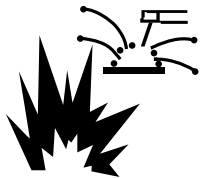

#### WELDING SPARKS can cause fire or explosion.

- Keep flammable material away.
- Do not weld on containers that have held combustibles.



#### ARC RAYS can burn.

- Wear eye, ear, and body protection.

Observe additional Safety Guidelines detailed in the beginning of this manual.

## OPERATOR'S INSTRUCTIONS

Once the system is properly set up, the operator can make production welds *without readjusting the controls* using the following simple instructions:

1. Be sure there is enough electrode in the machine to complete the weld.
2. If submerged arc welding, fill flux hopper with new or freshly screened flux. All reused flux must be screened 100% through an 8 mesh screen [0.065 to 0.075 in. (1.6 to 1.9 mm) opening]. Turn the switch on the hopper to "On."
3. Start the power source.
4. Turn the "Power Control" switch on the wire feeder control to "On."
5. Position the welding head at the start of the weld. Be sure the travel carriage or other travel mechanism is set to move in the proper direction.
6. Set the travel switch to "Automatic Travel." When set to "Hand Travel", the travel system operates without welding.
7. For best starts, cut the electrode to a sharp point.
8. Press the "Inch Down" button to feed the electrode out of the nozzle.
  - a. For most applications, when hot starting, leave the electrode 1/4 in. (6.4 mm) or more away from the work.
  - b. When cold starting some submerged arc welding, inch the electrode down until it touches the work and the flux valve opens.
9. Press the "Start" button.
10. While welding, turn the cross seam adjuster handwheel as needed to keep the arc in the joint.
11. At the end of the weld, press the "Stop" button.
12. If needed, press the "Inch Up" button to get the electrode up and out of the way. Remove the work and reload the fixture.

**NOTE:** When the contact tip in the end of the nozzle wears during repetitive welding, it must be replaced. Check the contact tip for wear if weld quality seems to be deteriorating.

NA-5

**LINCOLN**<sup>®</sup>  
ELECTRIC

## CONTROLS AND THEIR FUNCTIONS

The operator controls for the NA-5 are illustrated in Figure B.1. Refer to the figure and the following explanations of the controls.

### EXPOSED CONTROLS (WITH LOCKABLE COVER DOWN)

1. **CIRCUIT BREAKER.** Protects the circuit from severe wire feed motor overloads and short circuits. Press to reset.
2. **CONTROL POWER.** Turns input control power "On" and "Off." Also used as an emergency "Off" in case of malfunction.
3. **ELECTRODE "HOT" LIGHT.** Comes on when the "Start button" is pressed and the electrode circuit becomes electrically hot.

FIGURE B.1 – NA-5 CONTROLS.

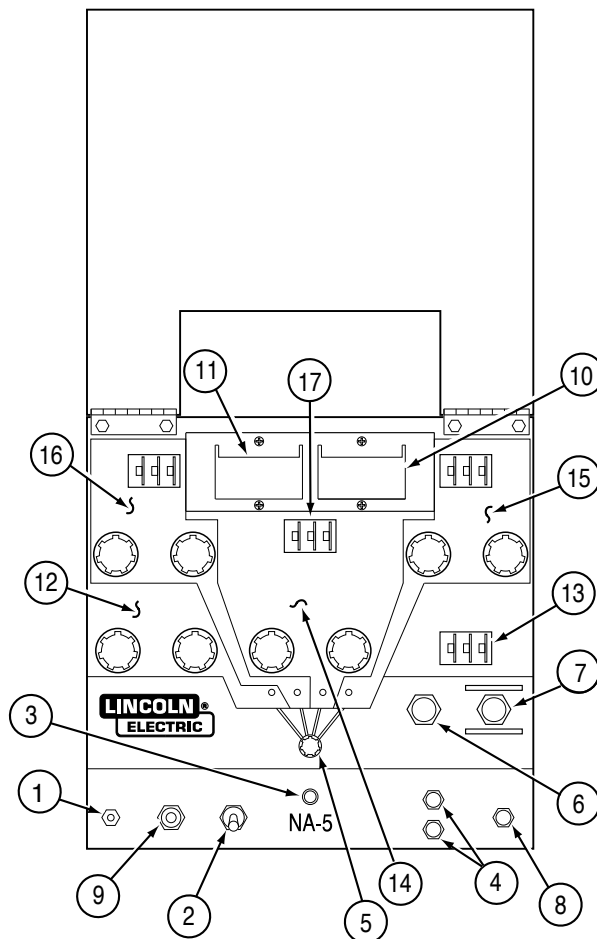

NA-5

**LINCOLN**  
ELECTRIC

4. **INCH UP AND INCH DOWN.** Press to inch electrode up or down.
5. **MODE SELECTOR SWITCH AND LIGHTS.** Used to preset the voltage and wire feed speed for the various modes of operation (Strike, Start, Weld, and Crater).
6. **SET-ACTUAL BUTTON.** When pressed, will display the actual wire speed and voltage in the wire speed and volts meters. When the button is not pressed, the set wire speed and voltage is displayed.
7. **START.** Begins welding cycle.
8. **STOP.** Initiates the stopping cycle at the end of the weld.
9. **TRAVEL.** Turn to "Off" for no travel, "Hand Travel" for travel without welding, and "Automatic Welding" for welding operations.
10. **VOLTS METER.** Displays the set or actual voltage for each mode (Strike, Start, Weld, Crater).
11. **WIRE SPEED METER.** Displays the set or actual wire speed for each mode (Strike, Start, Weld, Crater).

### CONTROLS UNDER THE LOCKABLE SECURITY COVER

12. **ARC STRIKING CONTROLS.** Sets the wire speed until the welding current begins to flow and controls the power source voltage during arc striking.
13. **BURNBACK AND ELECTRODE BACKUP TIME.** Controls the length of burnback delay time after the stop circuit is energized.
14. **WELD CONTROLS.** Controls the voltage and wire speed during the welding mode.
15. **CRATER CONTROLS (OPTIONAL).** Sets the ending current and voltage for an adjustable period of time.
16. **START CONTROLS (OPTIONAL).** Sets the starting current and voltage for an adjustable period of time.
17. **WELD TIME (OPTIONAL).** Controls the time of the weld mode.

## SETUP INSTRUCTIONS

Use the following steps to set up the NA-5 welding system prior to welding:

1. If using a multi-process power source (SAM, DC-400, DC-600, DC-1000, OR DC-1500 type), make connections and settings per the power source connection diagram (Figures **A.8** to **A.14**) for the process being used.

### AUTO TAB

When using the NA-5 with the DC-400 or CV-400 power source, the auto tab jumper on the NA-5 voltage PC board must be connected in order for the inch down circuit to function. When the auto tab jumper is connected, the cold starting feature of the NA-5 is disabled and only the hot starting technique can be used. If the cold start technique is to be used, the optional Diode must be installed on the DC-400 or CV-400.

2. Set the power source and NA-5 circuit polarity per information on **Electrode Polarity** in Section A, Installation.
3. Depending on the procedures and applications, decide:
  - a. The means of arc striking and whether to start the travel with the "Start" button or the arc.
  - b. Whether the initial bead size or penetration requires use of the optional "Start Controls."

See the **Starting and Stopping Sequences** section.

4. Depending upon the procedures and applications:
  - a. Select the arc and travel stopping sequence. See the **Starting and Stopping Sequences** section.
  - b. Decide if the control of the ending bead size or crater fill requires the use of optional "Crater Controls". See the **Starting and Stopping Sequences** section.

5. Set the head position relative to the work as required for the fixture, application, and procedures. See IM305 Sec. T3.2.3.
6. Rotate the wire straightener, if used, until the top of the straightener faces the wire reel. This is required for smooth feeding of the electrode into the straightener.
7. Refer to the instructions for the wire contact assembly being used. See IM305 Sec. T2.2.6, T2.2.7, T2.5.3, or T2.5.4.
8. The mount for standard 50 and 60 lb (22.7 and 27.2 kg) electrode coils includes a two-position brake assembly. Generally the brake should be at the inner position (nearest to the wire reel shaft) for wire feed speeds below 400 in./min (10 m/min). It should be at the outer position for faster wire speeds. To adjust the brake position, remove the wire reel. Pull the cotter pin that holds the brake shoe to the arm, move the shoe, and replace the cotter pin. Do not bend the cotter pin — it is held in place by a friction fit.
9. Load the wire reel per IM305 Sec. T3.2.2 or install the Speed-Feed drum or reel per Sec. T2.5.7-A or -B.
10. Straighten the first 6 in. (152.4 mm) of electrode and push it through the wire straightener to the drive rolls. To use the cored wire straightener, remove the knurled nut at the top and feed the wire through the nut, down through the straightener, and into the drive rolls. Screw the nut back onto the straightener. Feed the wire through the nozzle tip and adjust the straightener for optimum straightness. With wire contact assemblies, except the K231, adjust until the electrode is straight as it comes out of the nozzle. Do not completely straighten the wire when using the K231 contact nozzle because the nozzle relies on the small curvature of the electrode for proper electrical contact within the contact tip.

NA-5



11. Set the travel speed as specified by the procedures. With the wire feeder travel switch set to "Hand Travel", the travel runs without welding, permitting accurate measurement of travel speed. When using a Lincoln travel carriage, adjust the speed with the rheostat and the direction with the toggle switch on the carriage control panel.
12. Connect the work lead to the work or a suitable piece of scrap. Clip the end of the electrode to a sharp point.
13. Preset the "Start" (if used), "Weld", and "Crater" (if used) controls to the wire speed and voltage specified in the procedure.
14. Make several test welds, readjusting the controls in the following order:
  - a. Set the "Arc Striking", "Inch Wire Speed", and "Volts" controls for optimum arc striking. The optimum strike control settings for most processes will be typically 4 to 5 volts higher than the weld mode voltage setting and 40% to 50% of the weld mode wire feed speed setting (possibly lower if cold starting is used).
  - b. If striking is still not satisfactory, refer to the section on **Setting Travel Starting and Stopping** or IM305 Sec. T3.5.2 for information on wire feed motor acceleration.
  - c. If installed, adjust the "Start Controls" to set the welding procedures for the time set on the timer to provide the bead size, penetration, or other factor as needed for the application.
  - d. If installed, adjust the "Crater Controls" to set the welding procedures for the set time after the "Stop" button is pressed to provide the bead size or fill the crater as needed for the application.
  - e. Set the "Burnback Time" to provide the stopping characteristics needed.

## STARTING AND STOPPING SEQUENCES

### MEANS OF ARC STRIKING

The NA-5 Codes utilize "hot start" arc striking which operates as follows:

1. With the electrode not touching the work, press the "Start" button.
2. The electrically "hot" electrode inches down as set by the "Inch Wire Speed" control.
3. When the electrode makes contact with the work, the arc strikes and the circuit automatically switches from "Strike" settings to "Weld" (or "Start", if used) settings.

NA-5 models above Code 8300 offer both "hot start" arc striking, as described above, or "Cold Start" arc striking which operates as follows:

1. Press the "Inch Down" button until the tip of the electrode touches the work, automatically stops, and the flux (if used) is automatically dispensed.

**NOTE:** If inch speed is set too high, the electrode may stop with too much force on its tip, resulting in possible poor starting.

2. The arc establishes when the "Start" button is pressed, and the circuit automatically switches to "Weld" (or "Start", is used) settings. Should the arc not start immediately, the wire will retract slightly until the arc is established and then feed down in the normal manner.

Use either the standard "on-the-fly" travel starting or rewire the controls for "standstill" travel starting as described in the **Setting Travel Starting and Stopping** section.

### Optional "Start Controls"

Recommended for applications where penetration, bead size, and other characteristics must be carefully controlled at the start.

NA-5



The starting sequence is as described above except that when the arc strikes, the machine welds at the wire speed and voltage set by the “Start Controls” panel until the time set on the thumbwheel switch elapses. The circuit then automatically switches to the “Welding Controls” wire speed and voltage. Actual settings depend on application requirements.

#### Available options for applications with particularly difficult starting.

1. K238 High Frequency Generator - See IM305 Sec. T2.5.8.

## SETTING TRAVEL STARTING AND STOPPING

Standard machines can be connected for a variety of starting and stopping sequences.

### STARTING SEQUENCES

#### “On-the-Fly” Travel Starting

When shipped, all models are connected for “On-the-Fly” travel starting. The starting sequence is as follows:

1. With the electrode NOT touching the work, press the “Start” button. This starts both the wire feed and travel motors.
2. When the electrically “hot” electrode touches the work to start the arc, there is relative motion between the end of the electrode and the work. This “scratching” type contact helps assure consistent arc striking.

This sequence is recommended for most welding applications including:

1. Roundabouts and any other weld which ends at its starting point. A K337 Weld Timer Module to control the welding cycle duration can be installed.
2. Welds started on a run-out tab.

3. Any application for improved arc striking.

#### “Standstill” Travel Starting

All models can be reconnected so the travel remains at a standstill until the arc starts. “Standstill” travel starting is used when the electrode *must* be started at a precise location.

For consistent arc striking with “Standstill” travel starting, always clip the end of the electrode to a sharp point before starting.

### STOPPING SEQUENCES

As shipped, the travel stops when the “Stop” button is pressed, producing a small crater area.

When the end of the weld overlaps the beginning, changing the stopping sequence to stop the travel later spreads the crater over a longer area.

### RECONFIGURING THE TRAVEL SEQUENCES

#### WARNING



#### ELECTRIC SHOCK can kill.

- Turn off input power to the welding power source using the disconnect switch before working on this equipment.

To change the travel sequence, turn off all input power to the NA-5 control box. Open the control box. The logic board is mounted on the back of the box in the upper right hand corner. To change the travel circuit for the various modes of starting and stopping, follow the information in the wiring diagram for the NA-5 being used. **Table B.1** also shows information on reconfiguring the travel sequences.

NA-5

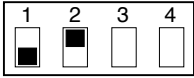
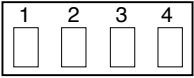
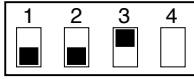
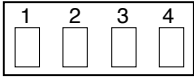
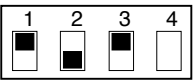
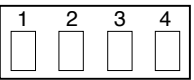
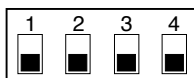
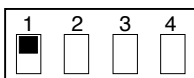
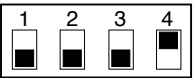
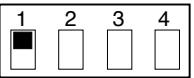

**LINCOLN**<sup>®</sup>  
ELECTRIC

TABLE B.1 – TRAVEL SEQUENCE LEAD AND SWITCH POSITIONS.

Travel Starts	Travel Stops	Older Models	Newer Models*
With "Start" Button	With "Stop" Button	Lead #691 to Pin 6 Lead #692 to Pin 5	 
With Arc Striking	With Arc Stopping	Lead #691 to Pin 6 Lead #692 to Pin 7	 
With Arc Striking	With Stop Button	Lead #691 to Pin 5 Lead #692 to Pin 7	 
With "Start" Button	With End Crater Fill Time (With optional procedure module installed in crater receptacle <sup>1</sup> )	Lead #691 to Pin 6 Lead #692 to Pin 9	 
With "Start" Button	After Burnback Time (with optional procedure module installed in crater receptacle <sup>1</sup> )	Lead #691 to Pin 6 Lead #692 to Pin 8	 

<sup>1</sup>If the optional procedure module is installed in the crater receptacle, DIP switch position 1 on switch #2 should be in the UP position as shown. Additionally, remove 583C to 584C jumper plug from the procedure board. If the procedure module is not installed, the switch should be in the down position and the 583C to 584C jumper plug should be reinstalled on the procedure board.

**\*NOTE:**

-  Indicates switch in up ↑ position
-  Indicates switch in down ↓ position
-  Indicates switch position does not matter

Return to Section TOC  
Return to Master TOC  
Return to Section TOC  
Return to Master TOC  
Return to Section TOC  
Return to Master TOC  
Return to Section TOC  
Return to Master TOC



## Wire Feed Motor Acceleration

**⚠ WARNING****ELECTRIC SHOCK can kill.**

- Turn off input power to the welding power source using the disconnect switch before working on this equipment.

The NA-5 has two different speeds of controlled wire feed motor acceleration. As shipped, the unit is connected for fast acceleration which is best for most applications. To change to the slower acceleration, turn off all input power to the NA-5 control box. Open the control box. Locate the Control PC Board mounted on the back of the box in the lower right hand corner. Change the jumper plug from the “F” pin to the “S” pin as shown in Figure B.2.

**FIGURE B.2 – ACCELERATION JUMPER PLUGS.**

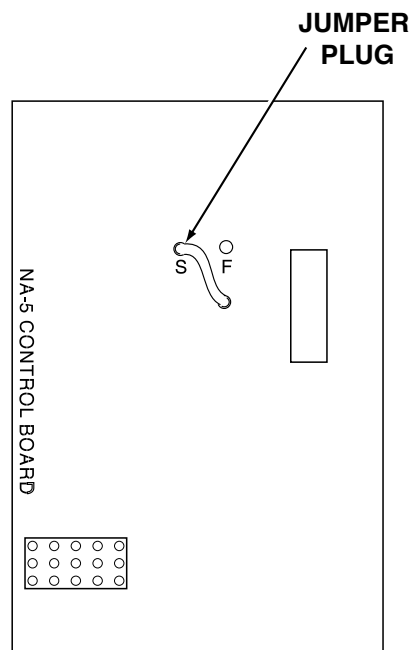
**Burnback and Electrode Backup**

The primary consideration in setting the arc stopping sequence is to prevent the electrode from sticking in the puddle. This is easily done with the machine as shipped.

The standard stopping sequence when the optional “Crater Controls” are not used is as follows:

1. Press the “Stop” button.
2. The wire feed motor stops and the “Burnback Time Delay” starts.
3. The arc continues to burn the electrode back from the puddle until the arc goes out or the time set on the thumbwheel switch elapses. This control should be set for just enough burnback time to prevent crater sticking.

There are two other ways this circuit can be connected. One will cause the wire to retract\* with a contactor drop out delay at the end of the weld. The second will cause the wire to retract\* during burnback time, and there will be no contactor drop out delay at the end of the weld. If either one of these alternate methods of stopping the weld is desired, the connections on the logic board can be easily changed.

To change the stopping sequence, turn the input AC power off at the power source, remove the screw holding the inner panel, and swing the panel open. Change the connections (older models) or switch positions (newer models) on the logic board as shown in **Table B.2**.

**Optional “Crater Controls”**

This option is recommended for applications where the ending bead size must be controlled, applications when the crater must be filled, roundabouts, and any other welds where the end overlaps the start.

When the “Stop” button is pressed, the machine welds at the wire speed and voltage set by the “Crater Controls” until the time set on the thumbwheel switch elapses. The circuit then automatically switches to the arc stopping sequence described above.

**NOTE:** Setting crater time to 0.00 seconds will give zero crater time; however, the crater settings will be active during burnback time until the arc goes out.



*\*Wire will retract at weld mode speed (or crater mode speed, if installed) until the arc goes out and then retract at strike mode speed for the remainder of burnback time.*

NA-5

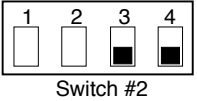
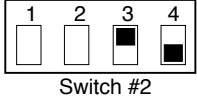
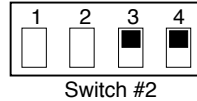
TABLE B.2 – STOPPING SEQUENCE SETTINGS.

When “Stop” Button is Pressed	Older Models	Newer Models*
Feed motor stops and electrode burns back with contactor delay (standard)	Lead #693 to Pin 3 Lead #690 to Pin 4	 Switch #2
Feed motor inches up and electrode burns back with contactor delay	Lead #693 to Pin 1 Lead #690 to Pin 4	 Switch #2
Feed motor inches up and contactor opens (no burnback)	Lead #693 to Pin 1 Lead #690 to Pin 2	 Switch #2

**\*NOTE:**

-  Indicates switch in up ↑ position
-  Indicates switch in down ↓ position
-  Indicates switch position does not matter

**VOLTAGE CONTROL RESPONSE**

The NA-5 is provided with selectable voltage control response. Proper setting depends on the power source and process being used. Refer to the appropriate power source connection diagram for the proper connection of the jumpers located on the NA-5 Voltage P.C. Board, shown in Figure B.3.

To change the voltage control response:

1. Turn off all input power to the NA-5 control.
2. Open the control box.
3. Locate the Voltage P.C. Board mounted on the right side of the box. Position the jumper plugs on the Voltage P.C. Board per the appropriate power source connection diagram.

**FIGURE B.3 – VOLTAGE CONTROL RESPONSE JUMPER PLUG LOCATIONS.**

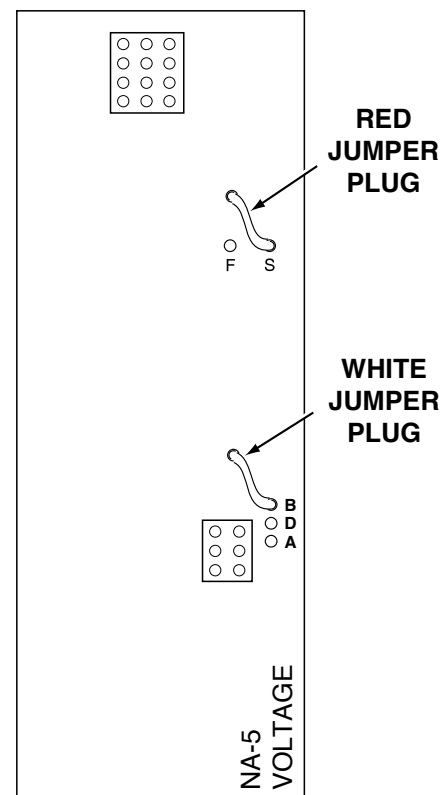

NA-5



Return to Section TOC

Return to Master TOC



## AUTOMATIC SHUTDOWN

If the NA-5 voltage control is unable to supply the “Set” value of the arc voltage while welding, the automatic shutdown circuit will activate. This protection circuit immediately returns the NA-5 control to idle state within a few seconds after the arc voltage discrepancy occurs.

Typical causes that activate this protective shutdown circuit are as follows:

1. “Set” value of arc voltage is outside the power source range.
2. Power source voltage control not set for “Remote”.
3. Misconnection of NA-5 control cable leads to the power source.
4. Incorrect weld polarity connections, or settings, at NA-5 or power source.
5. Lost connection of NA-5 voltage sensing leads (#67 and #21) between arc and voltage control or a blown 1/8 amp fuse on voltage PC boards built since 1983.

With NA-5 units above Code 8300, the conditions of causes 4 and 5 above would result in the wrong wire feed direction when the weld is started. See the section on **Cold Start Circuitry**.

In the case of full-range control power sources, such as the DC-600, this protective shutdown circuit could prevent welding under the conditions of causes 3, 4 and 5 above by holding the power output at minimum, possibly providing too low of a power source output to even establish an arc, or causing the field fuse to blow because of rapid field reversals with NA-5 controls above Code 8300. See the section on **Cold Start Circuitry**.

Although out of range shutdown can occur with all power sources when working with very low or very high arc voltages, it is most

likely to occur when using the R3S models with the somewhat limited voltage ranges of the various taps. For instance, if the R3S-400 triangle tap setting is for 31 volts, the range of control from the remote circuit is approximately 7 volts, i.e. 27.5 to 34.5 volts at nominal input voltage. If the NA-5 controls are set for 29 volts, and the input voltage to the R3S goes up, it may not be possible for the NA-5 control circuit to hold the 29 volts, so the welding will shut down. By changing to the 27 volt triangle setting, the range will be approximately 23.5 to 30.5 volts, and at high input voltage, there will be sufficient control to hold the “Set” arc voltage. On these machines, if the NA-5 stops welding, follow this procedure:

1. Move the NA-5 voltage set point 2 volts lower than the desired procedure and make a test weld.
  - a. If the NA-5 still shuts down, go to step 2 below.
  - b. If the NA-5 keeps welding, change the R3S triangle setting to the next higher voltage and reset the NA-5 set point to the desired procedure. The R3S is now set properly unless there is a significant change in input voltage. Skip the following step.
2. Move the NA-5 voltage setting set point 2 volts higher than the desired procedure and make a test weld.
  - a. If the NA-5 keeps welding, change the R3S triangle setting to the next lower voltage and reset the NA-5 set point to the desired procedure. The R3S is now set properly unless there is a significant change in input voltage. Skip the following step.
  - b. If the NA-5 still shuts down, refer to the following paragraph and other causes previously listed.

NA-5



In some cases, it is also possible to hold the “Actual” button pressed while starting the arc. Before the NA-5 shuts down, the actual arc voltage can be read on the digital meter. Comparing this reading to the “Set” reading will tell what change in the range controls of the power source are required so it can supply the desired voltage. Should the meter read zero, check the NA-5 sensing leads (#21 and #67) connections. Should the meter read negative (-) voltage, the polarity connections or settings at the NA-5 or power source are wrong.

This same general procedure can be used on the other power sources. For example, if the NA-5 keeps shutting down and the other possible causes have been checked, adjust the “Set” voltage higher and/or lower than the desired voltage. If the NA-5 continues to weld at one of these voltages, it can be determined what change in the range controls of the power source are required so it can supply the desired voltage.

## COLD START CIRCUITRY

NA-5 controls above Code 8300 contain circuitry added to the voltage PC board to facilitate the “cold starting” features of these units.\* This circuitry senses the voltage present between the electrode and work, via leads #67 and #21, and permits normal wire feed if this voltage exceeds approximately 6.5 VDC. However, if this voltage level is not exceeded, or drops below approximately 3.5 VDC, the “Auto Stop” activates while inching down or electrode backup occurs if the arc start circuit has been initiated.

*\*Units below Code 8300 can be provided with the cold start circuitry by replacing the old L-6257 voltage board with the new G-1556 voltage board. This new board will mount and connect in the same manner as the old board, except the third harness connector (previously connected to a jumper plug) must be connected to the lower receptacle of the new voltage board.*

**NOTE:** HI-FREQ starting cannot be used with converted units below Code 8300.

### A. Auto Stop

When the “Inch Down” button is pressed, a low-level DC voltage signal is applied between the electrode and work which permits the wire to inch down normally. When the electrode makes electrical contact with the work, it shorts out this signal causing the wire feed to automatically stop and the flux solenoid to activate until the “Inch Down” button is released. The “Inch Up” button is not affected by this circuit.

### B. Electrode Backup

If while starting or welding the electrode stubs or shorts to work, the resulting loss of arc voltage will cause the electrode to momentarily back up until the arc voltage is re-established and then change back to the normal feed direction.

**NOTE:** The “cold starting” circuitry will cause the NA-5 to feed in the wrong direction when the “Start” button is pressed if the “Actual” arc voltage, as read on the NA-5 voltmeter, does not exceed typically about 6.5 volts. Usual causes for the situation are:

1. No wire loaded through the NA-5 head and nozzle assembly (except when using the K148 Contact Nozzle).
2. No power source weld cable connection to the NA-5 head or work.
3. Incorrect electrode polarity connections at the NA-5 or power source.
4. Little or no output voltage from the power source.
5. An open voltage sensing lead #67 or #21 to the NA-5 control box or a blown 1/8 amp fuse on a voltage PC board built since 1983.

NA-5



## SECURITY OF WELD PROCEDURE SETTINGS

There are two means provided to prevent or limit unauthorized readjustment of the NA-5 voltage and wire feed speed controls once set to the desired procedure.

1. The security panel of the NA-5 can be locked to prevent access to the control knobs.
2. The control range of the procedure control knobs can be limited to either about 3% or about 15% of the full range control by installing a knob rotation stop screw to any or all of the control knobs. This stop screw is installed in the following manner:
  - a. Turn off the input power to the NA-5.
  - b. Loosen each knob set screw and remove all knobs, including the rotary select switch knob.
  - c. Remove the felt seal and square spacer tube mounted behind each control knob.
  - d. Open the control box. Disconnect, then remove, the procedure control PC board assembly and its panel insulation.
  - e. Install a 1/2 in. long, pan or round head, #4 sheet metal screw into the 0.10 in. diameter hole located beneath each square so the head is on the back side of the panel (inside the control box).
  - f. Remount the PC board assembly and its panel insulation. Reconnect the PC board and close and secure the control box.
  - g. Remount the rotary select switch knob and replace each square spacer tube and felt seal so the #4 screw protrudes between the tube and the felt seal.
  - h. Turn on the NA-5 input power and set the desired procedure by rotating the shafts of the controls.
  - i. Carefully replace each control knob so the #4 screw inserts into the center of the shorter length channel on the back of the knob for about 3% of the total range of control or into the center of the longer length channel for about 15% of the total range of control.
  - j. With finger pressure on the knob against the felt seal, carefully retighten the set screw of each knob.

**NOTE:** Steps h thru j will have to be repeated if it is desired to change the procedure settings to values outside the selected 3% or 15% control range limit.

NA-5



# TABLE OF CONTENTS

## - ACCESSORIES SECTION -

<b>Accessories</b> .....	<b>Section C</b>
General .....	C-2
Listing of Accessories .....	C-3
K29 Vertical Lift Adjuster .....	C-3
K58 Magnetic Separator .....	C-3
K96 Horizontal Adjuster .....	C-3
K129 Submerged Arc Small Wire Twinarc® .....	C-3
K148 Contact Nozzle and K149 Linc-Fill™ Long Stickout Extension .....	C-3
K218 Horizontal Fillet/Lap Attachment .....	C-3
K219 Flux Hopper Kit .....	C-3
K223 Solenoid Kit .....	C-3
K225 Submerged Arc Twinarc Kit .....	C-4
K238 High Frequency Unit .....	C-4
K239 Twinarc Kit for Innershield® Electrodes .....	C-4
K278 Spreadarc™ .....	C-4
K281 Solid Wire Straightener for Tiny Twinarc .....	C-4
K285 Concentric Flux Cone .....	C-4
K310 Flux Screen .....	C-4
K325 TC-3 Travel Carriage .....	C-4
K334 Start and Crater Controls .....	C-5
K336 Remote Interface Module .....	C-5
K337 Weld Timer Module .....	C-5
K349 Multi-Procedure Kit .....	C-5
S-22022 or S-22182 Current Relay .....	C-5
Speed-Feed Drum .....	C-5
Speed-Feed Reel .....	C-5

## GENERAL

This section contains a listing and short description of the accessories that are available with the NA-5 automatic welding system.

**TABLE C.1 – NA-5 AUTOMATIC WELDING SYSTEM ACCESSORIES.**

Product Number	Product Name
K29	VERTICAL LIFT ADJUSTER
K58	MAGNETIC SEPARATOR
K96	HORIZONTAL ADJUSTER
K129	SUBMERGED ARC SMALL WIRE TWINARC
K148	CONTACT NOZZLE
K149	LINC-FILL LONG STICKOUT EXTENSION
K218	HORIZONTAL FILLET/LAP ATTACHMENT
K219	FLUX HOPPER KIT
K223	SOLENOID KIT
K225	SUBMERGED ARC TWINARC KIT
K238	HIGH FREQUENCY UNIT
K239	TWINARC KIT FOR INNERSHIELD ELECTRODES
K278	SPREADARC
K281	SOLID WIRE STRAIGHTENER FOR TINY TWINARC
K285	CONCENTRIC FLUX CONE
K310	FLUX SCREEN
K325	TC-3 TRAVEL CARRIAGE
K334	START AND CRATER CONTROLS
K336	REMOTE INTERFACE MODULE
K337	WELD TIMER MODULE
K349	MULTI-PROCEDURE KIT
S22022 or S22182	CURRENT RELAY
	SPEED-FEED DRUMS
	SPEED-FEED REELS

NA-5



## LISTING OF ACCESSORIES

### K29 VERTICAL LIFT ADJUSTER

When mounted in the NA-5 head mounting system, the K29 Vertical Lift Adjuster provides quick hand crank adjustment of the vertical head position. It also has some horizontal adjustability as described in Sec. T3.2.3 of operator's manual IM305. Installation instructions are shipped with each K29 Vertical Lift Adjuster kit, are contained in the IM305 manual, and can be ordered as Sec. T2.2.11.

### K58 MAGNETIC SEPARATOR

Useful with any submerged arc equipment. The unit removes foreign magnetic particles from reused submerged arc welding flux. Operating instructions are included with the kit.

### K96 HORIZONTAL ADJUSTER

When mounted in the NA-5 head mounting system, the K96 Horizontal Adjuster provides quick hand crank adjustment of the horizontal head position. Installation instructions are shipped with each K96 Horizontal Adjuster kit, are contained in the IM305 manual, and can be ordered as Sec. T2.2.12.

### K129 SUBMERGED ARC SMALL WIRE TWINARC®

The Twinarc system provides for the feeding of two small solid wires through a single wire feeder. The Twinarc assembly includes a wire reel, reel brake, shaft and mounting bracket, drive roll, idle roll assembly, dual wire guides, and nozzle and contact tip or contact tip holder. Instructions are shipped with each kit, are contained in the IM305 manual, and can be ordered as Sec. T2.5.3 K129.

### K148 CONTACT NOZZLE AND K149 LINC-FILL™ LONG STICKOUT EXTENSION

This Innershield and submerged arc nozzle is designed for 0.062 through 3/16 in. (1.57 through 4.76 mm) wire at high currents. When long stickout [2 to 5 (50.80 to 127.00 mm)] is required, the K149 Linc-Fill Long Stickout Extension is recommended along with the K237 Linc-Fill Starting Relay. Instructions are contained in the IM305 manual and can also be ordered as Sec. T2.2.7.

### K218 HORIZONTAL FILLET/LAP ATTACHMENT

This special contact assembly automatically guides the electrode when making submerged arc horizontal fillet and lap welds to ensure accurate bead placement without expensive fixtures and clamps. Installation, operating, and maintenance instructions are shipped with each kit, are contained in the IM305 manual, and can also be ordered as Sec. T2.5.4.

### K219 FLUX HOPPER KIT

This flux hopper, which has an electric flux valve, can be mounted on NA-5N and NA-5NF heads for submerged arc welding. Installation instructions are included with each kit. The operator and maintenance instructions are contained in the IM305 manual and can also be ordered as Sec. T2.5.9.

### K223 SOLENOID KIT

The solenoid kit includes a valve to control water flow when using the cooling attachment on the K148 or K239 contact nozzle assembly. It opens when the start button is pressed and can be wired to close either when the stop button is pressed or when the arc goes out. Installation instructions are shipped with each kit.

NA-5





### **K225 SUBMERGED ARC TWINARC KIT**

The Twinarc kit provides for the feeding of two 5/64, 3/32, or 1/8 in. (1.98, 2.38, or 3.18 mm) solid wires through a single wire feeder. The electrode wire must be the same size. The assembly includes a wire reel, insulated reel mounting bracket, wire straightener, dual wire guides, nozzle, and contact block. Installation, operating, and maintenance instructions are shipped with each kit, are contained in the IM305 manual, and can be ordered as Sec. T2.5.3 K225.

### **K238 HIGH FREQUENCY UNIT**

This unit supplies high frequency to the welding leads for more positive starts, which may be required for certain difficult starting applications. Factory-installed insulation is required. Instructions are shipped with each unit. Installation instructions are contained in the IM305 manual and can be ordered as Sec. T2.5.8.

### **K239 TWINARC KIT FOR INNERSHIELD® ELECTRODES**

This kit provides for welding with two Innershield electrodes. Two 3/32 in. (2.38 mm) flux-cored electrodes are fed through a single wire feeder. Both wires must be the same size. The K239 kit includes the nozzle equipped for water cooling, drive rolls, drive roll locating collar, idle roll assembly, ingoing and outgoing guide tubes, wire straightener, wire reel, and wire reel mounting shaft and insulation. Instructions are included in the kit, are contained in the IM305 manual, and can also be ordered as Sec. T2.5.3 K239.

### **K278 SPREADARC™**

The primary application for this accessory is for hardfacing buildup using a Twinarc nozzle. The combination "Spreadarc-Twinarc" covers large areas quickly with smooth beads of minimum admixture with the base metal. Flux cored electrode, open

arc, and submerged arc procedures can be used. Instructions are shipped with the kit, are contained in the IM305 manual, and can also be ordered as Sec. T2.5.6.

### **K281 SOLID WIRE STRAIGHTENER FOR TINY TWINARC**

This wire straightener will straighten 0.045 through 3/32 in. (1.14 through 2.38 mm) wire diameters. It is recommended for welding procedures requiring long stickout and where wire position accuracy is essential. Instructions are shipped with the kit, are contained in the IM305 manual, and can be ordered as Sec. T2.5.5.

### **K285 CONCENTRIC FLUX CONE**

The concentric flux cone was designed to fit on the K148 Contact Nozzle alone, the K148 Contact Nozzle with a K149 Linc-Fill Long Stickout Extension, the K129 Submerged Arc Small Wire Twinarc, and the K391 nozzles. (The maximum electrical stickout when using the K149 Linc-Fill Long Stickout Extension will be 4 in. [101.6 mm.]). Use of this attachment results in the flux being fed concentrically around the electrodes. Installation, operating, and maintenance instructions are shipped with each kit, are contained in the IM305 manual, and can be ordered as Sec. T2.2.8 K285.

### **K310 FLUX SCREEN**

Useful for any submerged arc equipment. It removes foreign magnetic particles from reused submerged arc welding flux. Operating instructions are included in the kit.

### **K325 TC-3 TRAVEL CARRIAGE**

The K325 Travel Carriage carries the control box and wire drive head, in either direction, on a beam of suitable length and mechanical specifications. Two models are available: Standard and High Capacity.

### **K334 START AND CRATER CONTROLS**

Easily installed procedure and timer boards to permit adjustment of wire speed and voltage. Can be installed to function at either the start of the weld or at the end for crater filling. Installation, operating, and maintenance instructions are shipped with each kit and can be ordered as Sec. T2.5.13 K334.

### **K336 REMOTE INTERFACE MODULE**

Permits connection of customer-furnished remote start-stop and inch momentary contact closure or momentary 24 volt signals. Also used when a single remote signal is desired to start or stop multiple heads. This module replaces the earlier K336 Remote Pushbutton Interface Module. Installation and application instructions are shipped with each kit and can be ordered as Sec. T2.5.11 K336.

### **K337 WELD TIMER MODULE**

Permits setting of weld time for an adjustable period. Eliminates need to press the "Stop" button. Instructions are included in the kit.

### **K349 MULTI-PROCEDURE KIT**

The K349 Multi-Procedure Kit provides three additional weld mode procedure settings of wire feed speed and voltage, allowing the choice of four NA-5 weld mode procedures. Installation, operating, and maintenance instructions are shipped with each kit, are contained in the IM305 manual, and can be ordered as Sec. T2.5.19 K349.

### **S22022 OR S22182 CURRENT RELAY MODULES**

The current relay is useful to fixture builders and others who need a signal indicating that welding current is flowing. Installation, operating, and maintenance instructions are shipped with each kit. The S22022 relay module is suitable for dry circuit applications and it is rated at 2 Amps, 115 VAC or 28 VDC. This relay has both normally open and normally closed contacts. The S22182 relay module is suitable for applications requiring at least 10 mA current and it is rated at 3 Amps, 115 VAC or 28 VDC. This relay only has normally open contacts.

### **SPEED-FEED DRUM**

These drums must be set on a turntable which permits them to freely turn in a clockwise direction. Installation, operating, and maintenance instructions are contained in the IM305 manual and can be ordered as Sec. T2.5.7-A.

### **SPEED-FEED REEL**

These reels require dereeling equipment that permits the reel to rotate freely as the electrode is used. Installation, operating, and maintenance instructions are contained in the IM305 manual and can be ordered as Sec. T2.5.7-B.

NA-5





Return to Section TOC

Return to Section TOC

Return to Section TOC

Return to Section TOC

Return to Master TOC

Return to Master TOC

Return to Master TOC

NA-5



# TABLE OF CONTENTS - MAINTENANCE SECTION -

<b>Maintenance</b> .....	<b>Section D</b>
Control Box .....	D-2
General .....	D-2
Circuit Protection .....	D-2
Ground Fault Fuse Protection .....	D-3
Welding Head .....	D-3
Wire Drive Gear Box .....	D-3
Wire Drive Motor .....	D-4
Changing Wire Feed Gear Ratios .....	D-4
Wire Drive Mechanism .....	D-5
Wire Straighteners .....	D-5
Optional Features .....	D-6
Contact Assemblies .....	D-6
Wire Reel Mounting for 50 or 60 lb (22.7 or 27.2 kg) Coils .....	D-6
Travel Carriage .....	D-6
Vertical Lift Adjuster .....	D-6
Horizontal Adjuster .....	D-6
High Frequency Generator .....	D-6
Spreadarc .....	D-6

Return to Master TOC

Return to Master TOC

Return to Master TOC

Return to Master TOC

## CONTROL BOX

### GENERAL

Inspect the control box every 3 months. If needed, blow dirt out using *low* pressure air. No further maintenance should be required.

### CIRCUIT PROTECTION

The circuit breaker mounted on the left side of the control box protects the control circuit from short circuit conditions and from severe wire feed overloads. If it is open, determine and correct the cause for the overload. To reset the circuit breaker, push in the red button shown in Figure D.1.

FIGURE D.1 – CIRCUIT BREAKER RESET BUTTON.

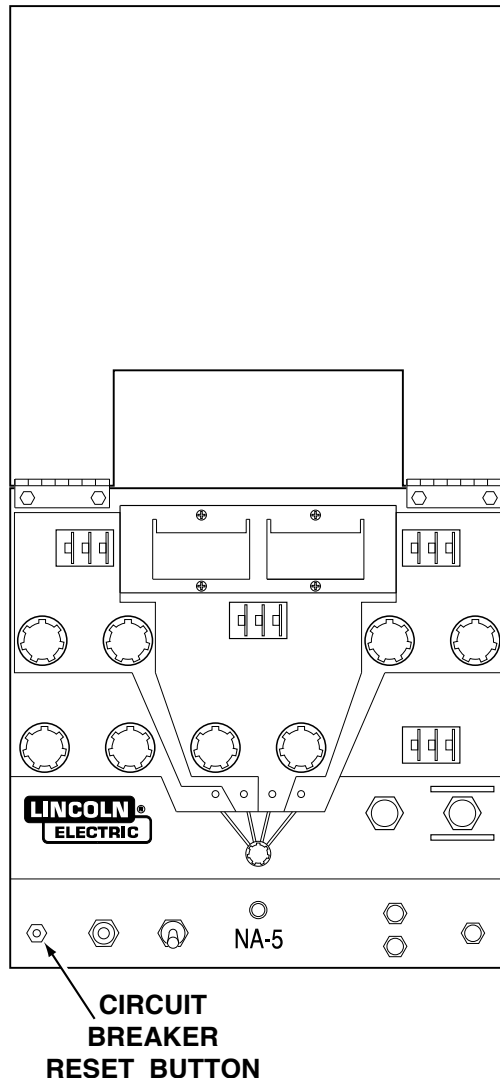

If a complete or partial short occurs in the field circuit, or if there is a defect on the PC board, a 1/2 amp slow-blow type fuse will blow. This field circuit fuse is mounted on the power PC board, shown in Figure D.2, inside the control box. Before replacing the fuse, check the motor field for a short condition. Normal resistance is approximately 700 ohms.

With NA-5 controls above Code 8300, the field circuit fuse may blow due to frequent motor field reversals from application problems affecting the “cold” starting circuit, such as the power source output being too low to establish an arc or the welding procedure causing frequent electrode-to-puddle shorting. (Refer to **Automatic Shutdown** in Section B, Operating Instructions.)

FIGURE D.2 – POWER PC BOARD FUSE LOCATIONS.

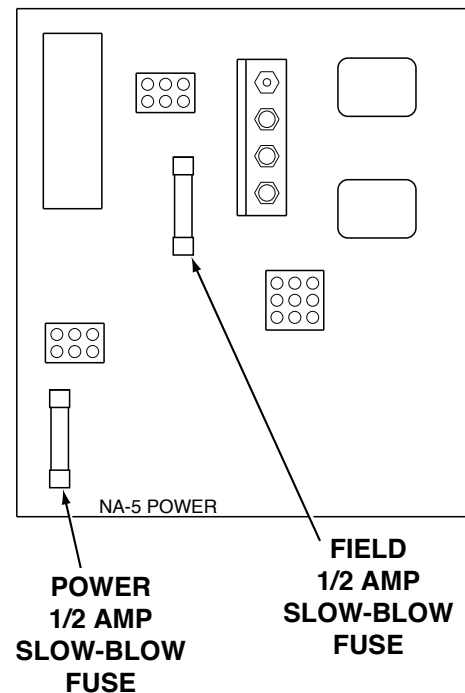

The power supply for the electronic circuitry is protected by a 1/2 amp slow-blow type fuse shown in Figure D.2. It is located on the power PC board inside the control box.

NA-5



Return to Section TOC  
Return to Master TOC

Return to Section TOC  
Return to Master TOC

Return to Section TOC  
Return to Master TOC

Return to Section TOC  
Return to Master TOC

The 1/8 amp fast-blow fuse, shown in Figure D.3, on a voltage PC board built since 1983, protects the NA-5 circuitry from damage which may result from a ground or case faulted control lead. If the fuse blows, the NA-5 voltage sensing lead circuit will be opened (Refer to **Automatic Shutdown** in Section B, Operating Procedures) and the Troubleshooting Guide.

**FIGURE D.3 – VOLTAGE BOARD FUSE LOCATION.**

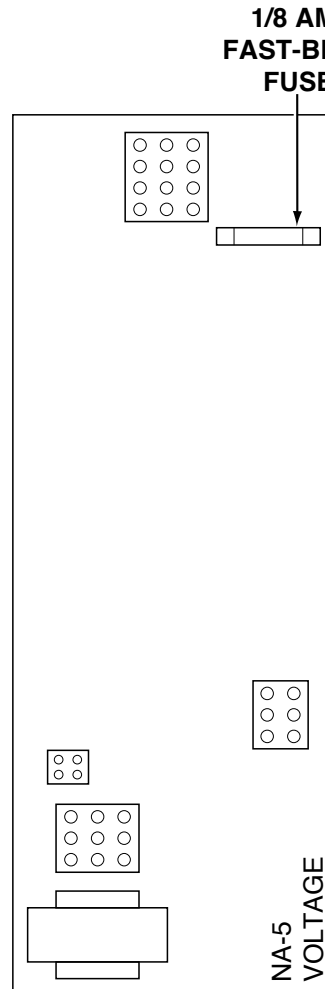

### GROUND FAULT FUSE PROTECTION

A 1/8 amp fast-blow fuse, shown in Figure D.3, is located on the voltage PC board. This fuse will protect the NA-5 circuitry from damage resulting from a ground or case faulted control lead when the arc voltage potential exists between ground and the

NA-5 circuit common (#510). Such a condition typically exists when the NA-5 polarity connections are set for electrode negative.

## WELDING HEAD

### WIRE DRIVE GEAR BOX

Once a year, recoat all gear teeth with a non-fluid molydisulfide type grease such as Non-Fluid Oil Corporation's A-29 Special/MS Lubricant. For access to the gears in the first chamber, remove the adapter plate and motor assembly as shown in Figure D.4.

**FIGURE D.4 – WIRE DRIVE MOTOR GEAR BOX.**

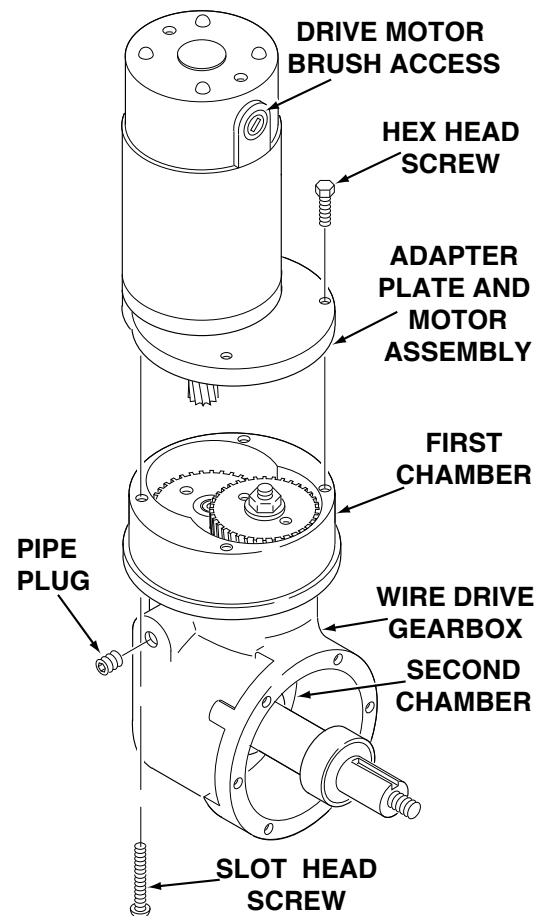

To lubricate the gears in the second chamber, remove one of the pipe plugs and feed grease until it comes in contact with the bevel gear teeth. Then, rotate the output shaft by hand until all teeth are lubricated.

NA-5

**LINCOLN**  
ELECTRIC

## WIRE DRIVE MOTOR

Periodically inspect the wire drive motor brushes, **Figure D.4**. Replace the brushes as needed.

## CHANGING WIRE FEED GEAR RATIOS

Four wire size conversion kits are available to modify the wire feeder for different size or type electrodes. The kits include drive rolls and guide tubes for the wire specified, as shown in Table D.1.

TABLE D.1 - CONVERSION KITS

Wire Type in. (mm)	Conversion Kit
3/32-7/32 (2.38-5.56) Solid or Cored	T13724-A
1/16-3/32 (1.59-2.38) Solid or Cored	T13724-B
0.035-0.052 (0.89-1.32) Solid	T13724-C
0.045-0.052 (1.14-1.32) Cored	T13724-D

Refer to Table D.2. Four gear ratios are available: 21:1, 57:1, 95:1, and 142:1. To change the gear ratio, replace the motor pinion and the first reduction gear per the following instructions (Refer to **Figures D.4**, **D.5** and **D.6**).

**NOTE:** Any item numbers in parentheses on Figure D.5 refer to item numbers in the task description breakdown.

FIGURE D.5 – CHANGING THE WIRE FEED GEAR RATIO

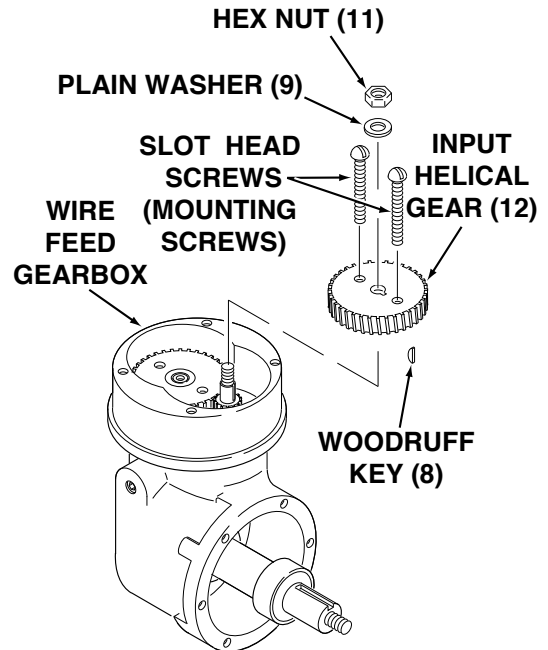

1. Remove the four screws that mount the adapter plate and motor assembly to the gear box. Remove the adapter plate and motor assembly from the gear box.
2. Take the two long screws removed in step 1 and screw one into each of the tapped holes located on the face of fiber input helical gear (12). Insert the screws through the full thickness of the gear, and using a screwdriver wedged between the screws to prevent rotation, remove hex nut (11) that holds the gear to the shaft. Remove plain washer (9).

TABLE D.2 – WIRE FEED GEAR RATIOS.

Gear Ratio	Feed Speed Range in./min (m/min)	Max Wire Size in. (mm)	
		Cored Wire	Solid Wire
21:1	100-2070 (2.54-52.58)	0.052 (1.3)	0.052 (1.3)
57:1	40-778 (1.02-19.76)	3/32 (3.0)	1/16 (1.6)
95:1	22-456 (0.56-11.58)	5/32 (4.0)	1/8 (3.2)
142:1	15-300 (0.38-7.62)	5/32 (4.0)	7/32 (5.6)

3. Pull the gear from the shaft using the screws as a pulling device.
4. Be certain woodruff key (8) is properly located on the shaft. Screw the adapter plate and motor assembly mounting screws into the new fiber input helical gear from the stenciled side and place the gear on the shaft. Replace plain washer (9), tighten the hex nut (1), and remove the adapter plate and motor assembly mounting screws from the gear.
5. After noting the relation of the adapter plate with the motor leads, remove the adapter plate from the wire drive motor. See Figure D.6. Support the pinion properly and, with the proper size punch, drive the roll pin that holds the pinion out of the shaft. Pull the pinion off. Install the new pinion and replace the roll pin. Replace the adapter plate in its original location.
6. Cover the teeth of the motor pinion and the input gear with a non-fluid molydisulfide type grease such as Non-Fluid Oil Corporation's A-29 Special/MS Lubricant. This grease can be scooped from the cavity of the gear case.
7. Reassemble the motor on the gear box; make sure the gears mesh properly and the adapter plate locating bead is in its cavity. Replace and tighten the four screws removed in step 1.
8. Jumper on wire speed meter PC board must be properly positioned for the gear ratio and drive rolls being used (See the wiring diagram for the wire speed meter PC board.)

## WIRE DRIVE MECHANISM

Drive mechanisms for three wire size ranges are available: 0.035 through 0.052 in. (0.9 through 1.3 mm), 1/16 through 3/32 in. (1.6 through 2.4 mm), and 3/32 through 7/32 in. (2.4 through 5.6 mm). If changing to wire sizes outside this range, change the drive rolls and the incoming and outgoing guide tubes. Also change the gear ratio as necessary.

**FIGURE D.6 – DRIVE MOTOR PINION GEAR REMOVAL.**

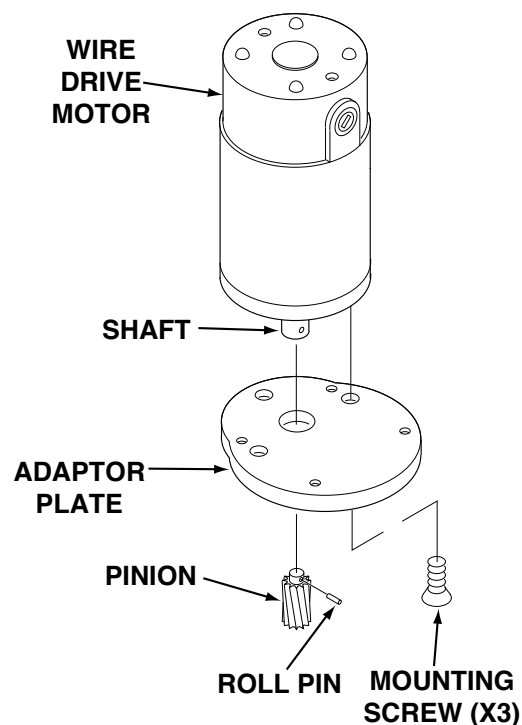

The electrode is driven by gripping between the grooved drive rolls and spring-loaded idle roll. Replace the drive rolls when they become worn. The drive rolls for 1/16 in. (1.6 mm) and larger diameter electrodes have two sets of teeth so they can be reversed once before they must be replaced.

## WIRE STRAIGHTENERS

### Solid Electrode

Periodically inspect the slide bushing at the top of the straightener and the ingoing wire guide at the bottom of the straightener for signs of wire milling. If necessary, rotate the guide to present an unworn surface. To reverse the slide bushing for a fresh wear surface, remove the cross adjustment screw and turn the bushing over.

### Flux-Cored Electrode

Severe wear at the "V" groove in the curved arm of the straightener can result in wire wander at the arc. Periodically check the groove and replace the arm when badly worn. Also replace the ingoing guide at the top of the straightener if it shows signs of wire milling.

## OPTIONAL FEATURES

### CONTACT ASSEMBLIES

A dirty or rusty electrode and excessively high currents cause rapid wear of the contact tips. The nozzle contact tip must be replaced when it no longer provides accurate wire location or good electrical contact. See Sec. T2.2.6, Sec. T2.2.7, or Sec. T2.5.3 of the IM305 manual for specific instructions to replace contact tips and to perform maintenance on other various contact assemblies.

### WIRE REEL MOUNTING FOR 50 OR 60 LB (22.7 OR 27.2 KG) COILS

Periodically coat the reel shaft with a thin layer of grease. No maintenance of the two-position adjustable brake is needed except to replace the shoe assembly if it wears through.

### TRAVEL CARRIAGE

Periodically:

1. Disengage the release handle and see that the carriage moves freely along the beam.
2. Add a few drops of machine oil to each of the head lift bearings. This can be done through the front opening in the carriage.
3. Add a few drops of oil to the clutch handle bearings.
4. Add a few drops of oil into each of the cups at the travel mounting pivot point.

(No change of lubrication is required for cold temperature operation.)

Once a year:

1. Check the motor brushes. If 0.25 in. (6.35 mm) or shorter, replace with new brushes.

2. Check the carriage drive gear teeth. If the teeth are badly worn, replace the drive gear.
3. After 5,000 hours of operation, the motor and the first reduction gear should be removed from the gear box, and all the gear teeth should be recoated with a good grade of graphite grease.

### VERTICAL LIFT ADJUSTER

Every month, add a few drops of SAE-140 oil or equivalent to the oil cup on the back of the vertical lift housing. Every year, replace the grease in the top section gear cavity with a medium grease. If the unit is disassembled for cleaning, apply a layer of medium grease to the screw threads of the head lift tube and head lift screw. Apply a thin layer of grease to the outside diameter of the head lift tube and the inside diameter of the long hole in the head lift body. Slide the head lift tube into the head lift body and screw in the head lift screw. Fill the upper section gear cavity one-half full of grease. Be sure the needle bearings are packed in grease.

### HORIZONTAL ADJUSTER

Twice a year, apply a thin coat of grease to all sliding surfaces. Every year, replace the grease in the gear cavity with a medium grease.

### HIGH FREQUENCY GENERATOR

Inspect the spark gaps monthly and maintain the setting specified on the spark gap cover plate.

### SPREADARC

Refer to the maintenance information provided in IM305 Sec. T2.5.6.



**TABLE OF CONTENTS  
-THEORY OF OPERATION SECTION-**

<b>Theory of Operation .....</b>	<b>Section E</b>
General Description .....	E-2
Input Power Circuits.....	E-2
Power and Voltage Boards .....	E-3
Control, Logic and Procedure Boards .....	E-4
Optional start, Crater Fill and Weld Timer Boards .....	E-5
SCR Operation .....	E-6

Return to Master TOC

Return to Master TOC

Return to Master TOC

Return to Master TOC

## GENERAL DESCRIPTION

The NA-5 is a fully automatic wire feed control unit. It is designed for multiple process CV operation and can be used with a variety of wire feeder heads, contact nozzles and welding processes. The NA-5 control unit enables the operator to preset wire feed speed and

arc voltage on digital meters. These preset conditions are internally monitored and remain constant until changed by the operator.

FIGURE E.1 Input Circuits

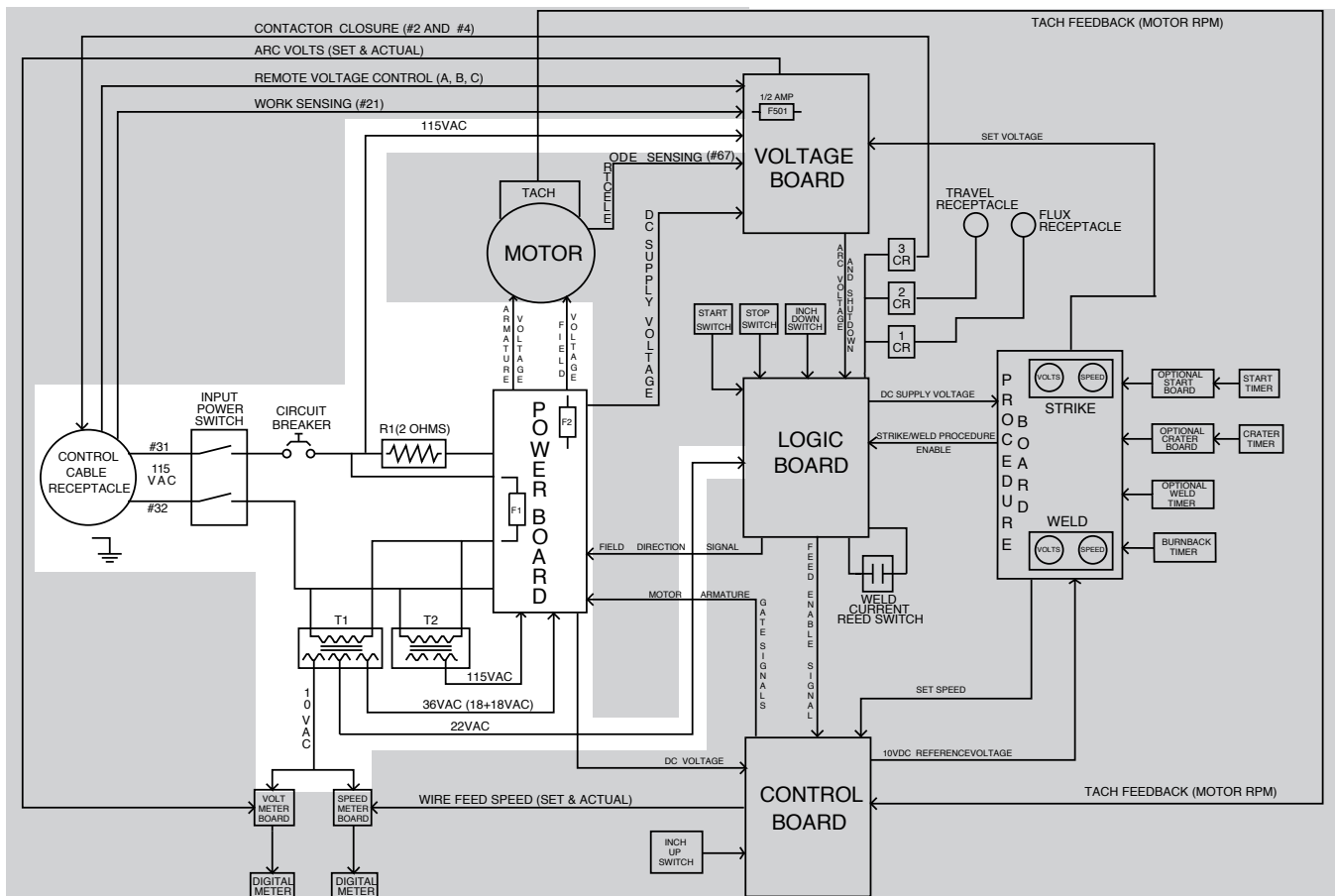

## INPUT POWER CIRCUITS

The NA-5 control unit is supplied with 115VAC power usually from the welding power source. The 115VAC power is connected to the control box circuitry through the control cable receptacle, the input power switch and a 5 amp circuit breaker.

The 115VAC is applied through a 2 ohm resistor to the power board where it is rectified and controlled to supply armature and field voltage to the wire

drive motor. The voltage board receives 115VAC and transforms and rectifies it to 24VDC for the "work touch sensing" circuit. The T1 and T2 transformer primaries are also supplied with 115VAC via the F1 (1/2amp) fuse on the power board. The T1 and T2 secondary windings offer a variety of isolated AC supply voltages to the power, logic and meter boards.

**NOTE:** Unshaded areas of block logic diagrams are the subject of discussion.

FIGURE E.2 Power and Voltage Boards

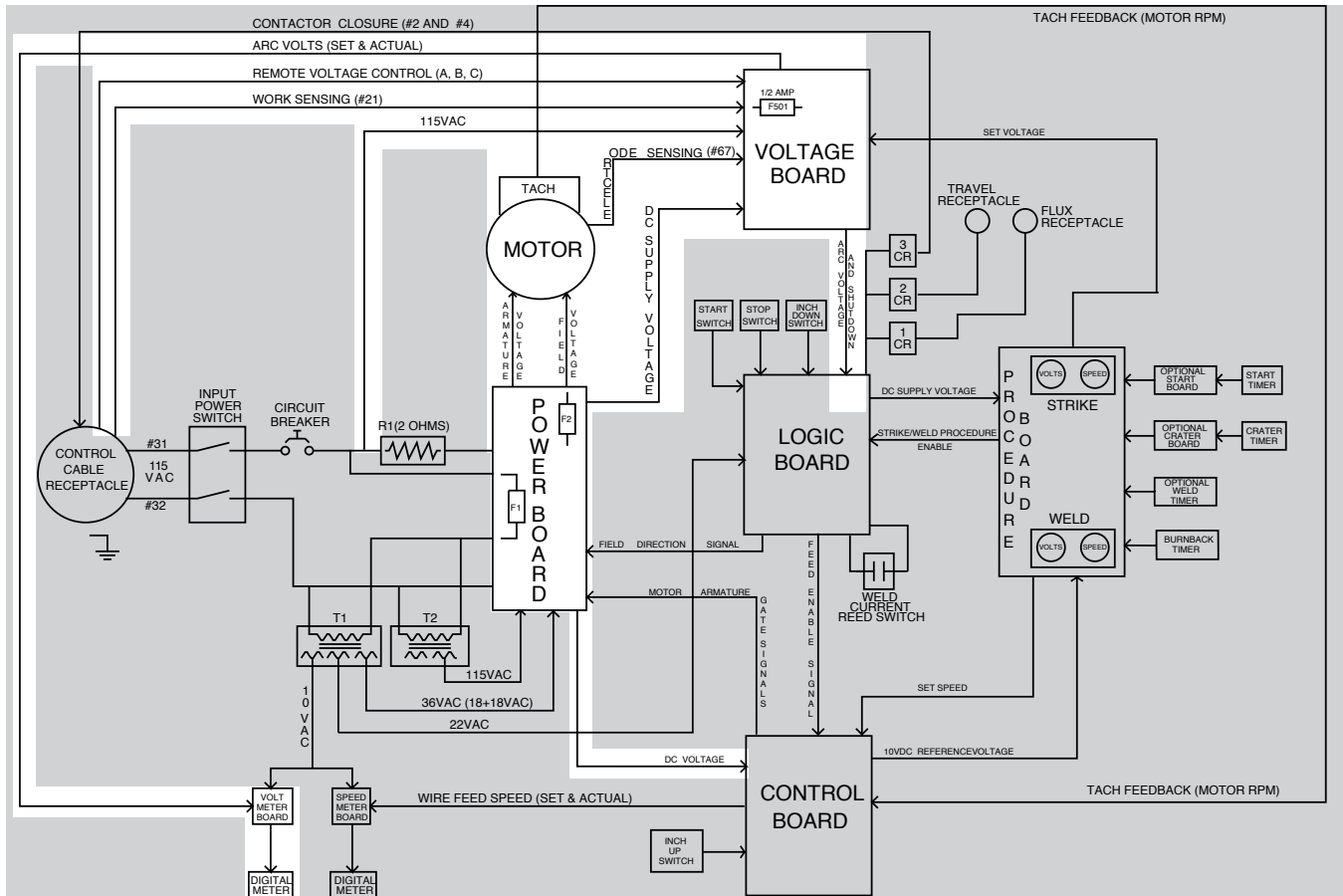

## POWER AND VOLTAGE BOARDS

The AC voltages that are received by the power board are rectified and regulated. These DC voltages are supplied to the motor, voltage board and control board. The two SCR-controlled 115VDC supplies power the motor armature and field circuits.

The actual arc voltage is sensed at leads #67 (electrode) and #21 (work) which are coupled to the voltage board. The preset voltage requirements are also sent to the voltage board. This information is compared and processed on the voltage board and the resultant correction signal is sent to the Lincoln CV power source via the remote voltage control leads (A, B, C). The preset and actual arc voltage information is also sent to the voltage meter board where it is processed and displayed on the digital

meter.

The voltage board also generates a low DC voltage that is applied to the electrode during the inch down mode. When the electrode makes contact with the work piece, this low voltage is "loaded down", signaling the control circuitry to stop the wire feed motor. This feature allows the operator to utilize the "work touch sensing" feature.

If for any reason the actual welding arc voltage does not match the set weld voltage (+/- 0.5Volts) the NA-5 will shutdown. This feature insures that the actual welding voltage is the same as the preset voltage during the welding cycle. This circuitry is incorporated on the voltage board.

**NOTE:** Unshaded areas of block logic diagrams are the subject of discussion.

FIGURE E.4 Control Logic and Procedure Boards

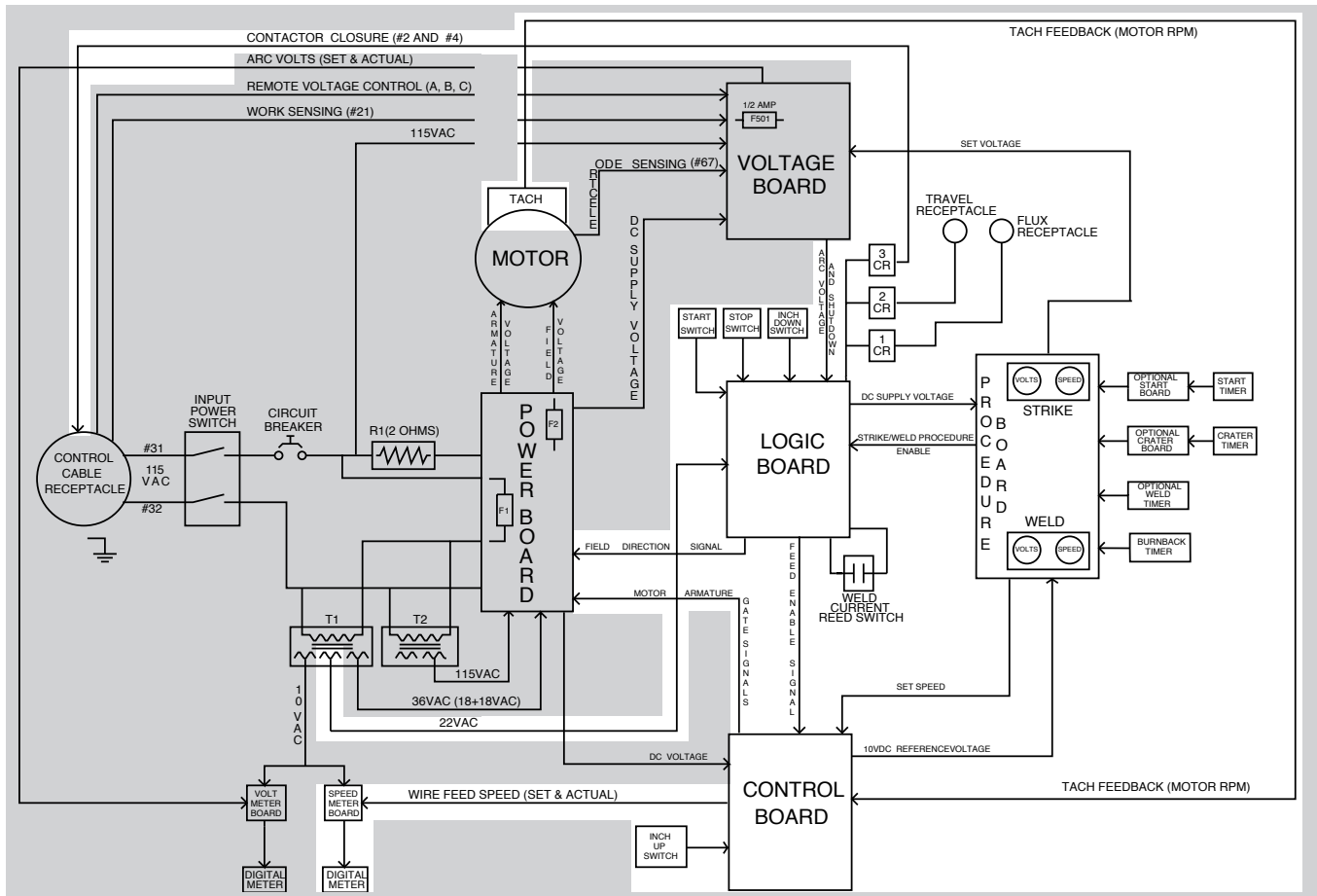

## CONTROL, LOGIC AND PROCEDURE BOARDS

The logic board interprets and processes the signals it receives from the various PC boards, switches and controls. The logic board also houses a DC power supply (+5 -10) which is derived from the 22VAC received from the T2 transformer. This DC voltage is also used on the procedure board.

Upon receiving voltage reference level commands from the procedure and voltage boards, or the user-operated switches, the logic board sends the appropriate command signals to the control and power boards to drive the wire feed motor to the proper speed and direction. When the "start" signal is received by the logic board the power source contact relay (3CR) is energized along with the travel relay (2CR) and the flux relay (1CR). The "inch down" and "stop" switches signal the logic board which then directs the control and power boards to apply the appropriate armature and field voltages to the wire drive motor. The "inch up" switch, which is connected directly to the control board, dictates that the wire drive motor reverse direction, backing the electrode wire away from the work piece. When the welding current closes the reed switch the logic board directs the

procedure board to proceed from the "strike" settings to the optional start board if used, or to the welding wire speed and arc voltage parameters.

The control board receives information from the logic board, the procedure board and the tach feedback circuit. The control board then applies the appropriate gate signal to the SCR power supply on the power board. This variable and regulated DC voltage is applied to the motor armature thus controlling the speed of the wire feed motor. The preset and actual wire feed speed information is sent to the speed meter board where it is processed and displayed on the digital meter.

The procedure board incorporates the many options available with the NA-5. The "strike" and "weld" controls are part of the procedure board and are not optional. The wire feed speed and arc voltage settings for the various modes are "programmed" through the procedure board and are then sent to the logic, voltage and control boards at the appropriate times during the welding cycle. The burnback time is also coupled through the procedure board. This control determines the length of time of burnback delay after the stop circuit is energized. Depending on the connections on the logic board, it may also determine the length of time the wire feed motor reverses after the stop button is pressed.

**NOTE:** Unshaded areas of block logic diagrams are the subject of discussion.

FIGURE E.3 Optional Start, Crater Fill and Weld Timer Boards

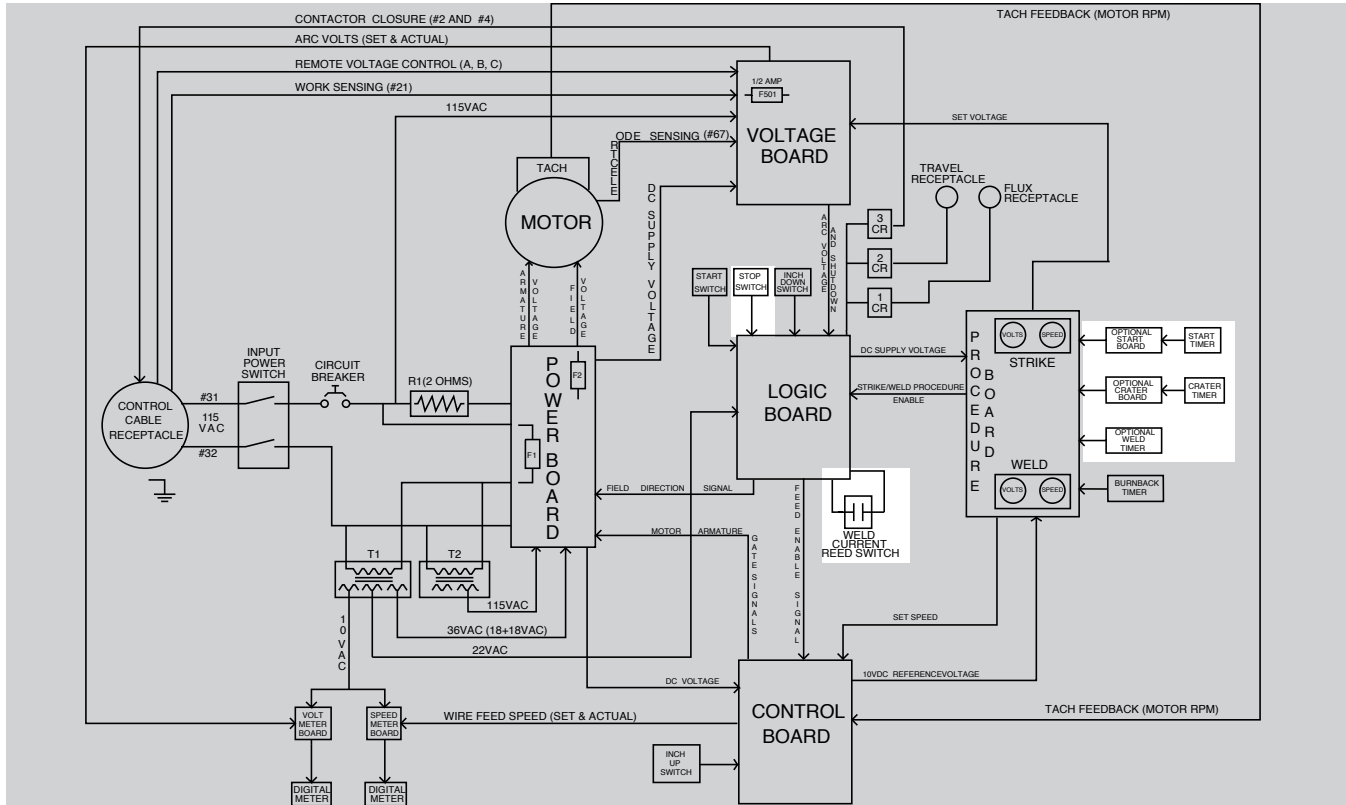

## OPTIONAL START, CRATER FILL AND WELD TIMER BOARDS

When installed, the optional start board dictates to the procedure board the starting wire feed speed and arc voltage. This condition can be operator set for a predetermined period of time. These parameters can be set either higher or lower than those of the welding procedure to control penetration, bead shape, or other factors at the start of the weld. The start circuit becomes active when the weld current sensing reed switch is closed.

The crater fill board is used by the operator to adjust the finishing wire feed speed and voltage either higher or lower than the welding procedure for an adjustable period of time. This circuit becomes active when the "stop"

switch is pressed. This optional feature is helpful in controlling bead shape and filling craters at the end of a weld.

The weld timer permits setting of weld time for an adjustable period of time. This feature eliminates the need to press the "stop" switch.

**NOTE:** Unshaded areas of block logic diagrams are the subject of discussion.

## SCR OPERATION

A silicon controlled rectifier (SCR) is a three terminal device used to control rather large currents to a load. An SCR acts very much like a switch. When a gate signal is applied to the SCR it is turned ON and there is current flow from anode to cathode. In the ON state the SCR acts like a closed switch. When the SCR is turned OFF there is no current flow from anode to cathode thus the device acts like an open switch. As the name suggests, the SCR is a rectifier, so it passes current only during positive half cycles of the AC supply. The positive half cycle is the portion of the sine wave in which the anode of the SCR is more positive than the cathode.

When an AC supply voltage is applied to the SCR, the device spends a certain portion of the AC cycle time in the on state and the remainder of the time in the off state. The amount of time spent in the ON state is controlled by the Gate.

An SCR is fired by a short burst of current into the gate. This gate pulse must be more positive than the cathode voltage. Since there is a standard PN junction between gate and cathode, the voltage between

these terminals must be slightly greater than 0.6V. Once the SCR has fired it is not necessary to continue the flow of gate current. As long as current continues to flow from anode to cathode the SCR will remain on. When the anode to cathode current drops below a minimum value, called holding current, the SCR will shut off. This normally occurs as the AC supply voltage passes through zero into the negative portion of the sine wave. If the SCR is turned on early in the positive half cycle, the conduction time is longer resulting in greater SCR output. If the gate firing occurs later in the cycle the conduction time is less resulting in lower SCR output.

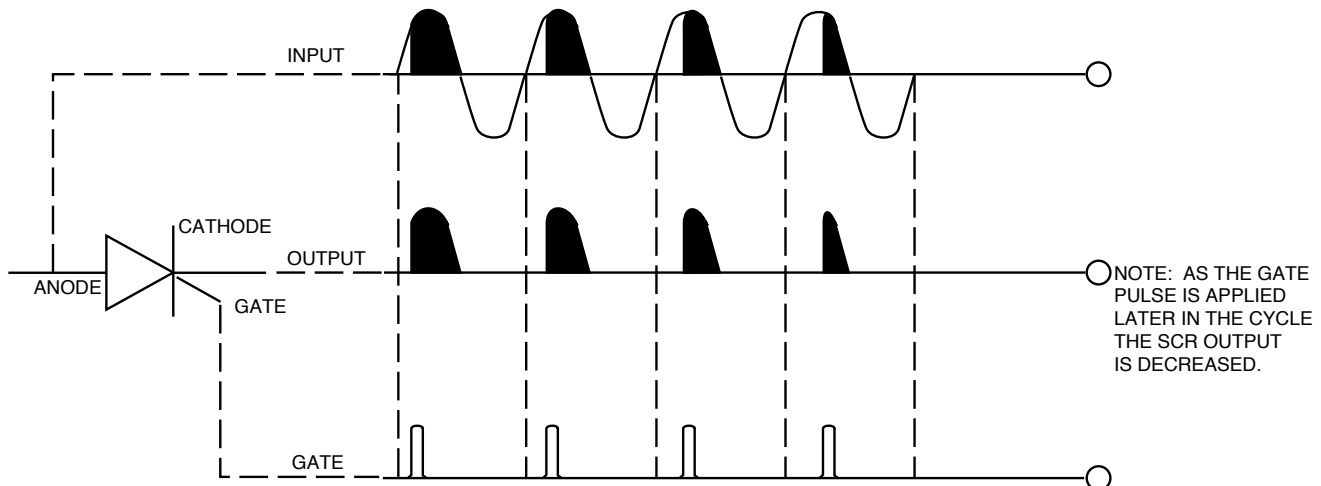

FIGURE E.4 SCR Operation

## TABLE OF CONTENTS

### -TROUBLESHOOTING AND REPAIR SECTION-

<b>Troubleshooting and Repair</b> .....	<b>Section F</b>
How to Use Troubleshooting Guide .....	F-2
PC Board Troubleshooting Procedures .....	F-3
Troubleshooting Guide .....	F-4
PC Board LED Definitions .....	F-36
PC Board LED Sequence Table .....	F-37
Test Procedures .....	F-38
DC Power Supply Test.....	F-38
T1 and T2 Transformer Test.....	F-42
Voltage Board Transformer Test.....	F-45
Wire Feed Drive Motor Test .....	F-48
External Resistance Test (Leads #21 and #67).....	F-50
Out of Voltage Range Shut Sown Test .....	F-52
Tach Board Feedback Test.....	F-55
VoltmeterAccuracy Test.....	F-57
Wire Speed Accuracy Test.....	F-60
Meter Circuit Accuracy Test .....	F-64
Replacement Procedures.....	F-71
PC Board(s) Removal and Replacement .....	F-71
Digital Meter and Meter PC Board Removal and Replacement .....	F-73
Tach PC Board Removal and Replacement .....	F-77
Wire Drive Motor Removal and Replacement.....	F-81
Retest After Repair .....	F-85



## HOW TO USE TROUBLESHOOTING GUIDE

### WARNING

Service and Repair should only be performed by Lincoln Electric Factory Trained Personnel. Unauthorized repairs performed on this equipment may result in danger to the technician and machine operator and will invalidate your factory warranty. For your safety and to avoid Electrical Shock, please observe all safety notes and precautions detailed throughout this manual.

This Troubleshooting Guide is provided to help you locate and repair possible machine malfunctions. Simply follow the three-step procedure listed below.

#### **Step 1. LOCATE PROBLEM (SYMPTOM).**

Look under the column labeled “PROBLEM (SYMPTOMS)”. This column describes possible symptoms that the machine may exhibit. Find the listing that best describes the symptom that the machine is exhibiting. Symptoms are grouped into the following categories: wire feeding problems, mode function problems, function problems and welding problems.

#### **Step 2. PERFORM EXTERNAL TESTS.**

The second column labeled “POSSIBLE AREAS OF MISADJUSTMENT(S)” lists the obvious external possibilities that may contribute to the machine symptom. Perform these tests/checks in the order listed. In general, these tests can be conducted without removing the case wrap-around cover.

#### **Step 3. RECOMMENDED COURSE OF ACTION**

The last column labeled “Recommended Course of Action” lists the most likely components that may have failed in your machine. It also specifies the appropriate test procedure to verify that the subject component is either good or bad. If there are a number of possible components, check the components in the order listed to eliminate one possibility at a time until you locate the cause of your problem.

All of the referenced test procedures referred to in the Troubleshooting Guide are described in detail at the end of this chapter. Refer to the Troubleshooting and Repair Table of Contents to locate each specific Test Procedure. All of the specified test points, components, terminal strips, etc. can be found on the referenced electrical wiring diagrams and schematics. Refer to the Electrical Diagrams Section Table of Contents to locate the appropriate diagram.

### CAUTION

If for any reason you do not understand the test procedures or are unable to perform the tests/repairs safely, contact the Lincoln Electric Service Department for technical troubleshooting assistance before you proceed. Call 216-383-2531 or 1-888-935-3877.

## PC BOARD TROUBLESHOOTING PROCEDURES

**! WARNING**

**ELECTRIC SHOCK can kill. Have an electrician install and service this equipment. Turn the input power OFF at the fuse box before working on equipment. Do not touch electrically hot parts.**

**CAUTION:** Sometimes machine failures appear to be due to PC board failures. These problems can sometimes be traced to poor electrical connections. To avoid problems when troubleshooting and replacing PC boards, please use the following procedure:

1. Determine to the best of your technical ability that the PC board is the most likely component causing the failure symptom.
2. Check for loose connections at the PC board to assure that the PC board is properly connected.
3. If the problem persists, replace the suspect PC board using standard practices to avoid static electrical damage and electrical shock. Read the warning inside the static resistant bag and perform the following procedures:



**ATTENTION  
Static-Sensitive  
Devices  
Handle only at  
Static-Safe  
Workstations**

**Reusable  
Container  
Do Not Destroy**

**P.C. Board can be damaged by static electricity.**

- Remove your body's static charge before opening the static-shielding bag. Wear an anti-static wrist strap. For safety, use a 1 Meg ohm resistive cord connected to a grounded part of the equipment frame.

- If you don't have a wrist strap, touch an unpainted, grounded, part of the

equipment frame. Keep touching the frame to prevent static build-up. Be sure not to touch any electrically live parts at the same time.

- Tools which come in contact with the P.C. Board must be either conductive, anti-static or static-dissipative.

- Remove the P.C. Board from the static-shielding bag and place it directly into the equipment. Don't set the P.C. Board on or near paper, plastic or cloth which could have a static charge. If the P.C. Board can't be installed immediately, put it back in the static-shielding bag.

- If the P.C. Board uses protective shorting jumpers, don't remove them until installation is complete.

- If you return a P.C. Board to The Lincoln Electric Company for credit, it must be in the static-shielding bag. This will prevent further damage and allow proper failure analysis.

4. Test the machine to determine if the failure symptom has been corrected by the replacement PC board.

**NOTE:** It is desirable to have a spare (known good) PC board available for PC board troubleshooting.

**NOTE:** Allow the machine to heat up so that all electrical components can reach their operating temperature.

5. Remove the replacement PC board and substitute it with the original PC board to recreate the original problem.

- a. If the original problem does not reappear by substituting the original board, then the PC board was not the problem. Continue to look for bad connections in the control wiring harness, junction blocks, and terminal strips.

- b. If the original problem is recreated by the substitution of the original board, then the PC board was the problem. Reinstall the replacement PC board and test the machine.

6. Always indicate that this procedure was followed when warranty reports are to be submitted.

**NOTE:** Following this procedure and writing on the warranty report, "INSTALLED AND SWITCHED PC BOARDS TO VERIFY PROBLEM," will help avoid denial of legitimate PC board warranty claims.

NA-5

Observe all Safety Guidelines detailed throughout this manual

PROBLEMS (SYMPTOMS)	POSSIBLE AREAS OF MISADJUSTMENTS(S)	RECOMMENDED COURSE OF ACTION
<b>WIRE FEEDING PROBLEMS</b>		
<p>The wire feeds whenever the input power switch is in the "ON" position.</p>	<ol style="list-style-type: none"> <li>1. Check the "Start" switch (S5). Make sure it is not stuck closed.</li> <li>2. Check the "Inch Down" switch (S4). Make sure it is not stuck closed.</li> <li>3. Check the "Inch Up" switch (S3). Make sure it is not stuck closed.</li> <li>4. Check to make sure that jumper lead #693 is connected to the proper pin on the logic board. See wiring diagram.</li> </ol>	<ol style="list-style-type: none"> <li>1. Check light 7B on the logic board. It should NOT be on. If light 7B is ON remove lead #518A from the "Start" switch. If the light remains ON the logic board may be faulty. If the light goes OFF check the switch and associated leads. See wiring diagram and <b>Figure F.1.</b></li> <li>2. Check light 7J on the logic board. It should NOT be on. If light 7J is ON remove lead #592 from the "Inch Down" switch. If the light remains ON the logic board may be faulty. If the light goes OFF check the switch and associated leads. See wiring diagram and <b>Figure F.1.</b></li> <li>3. Disconnect lead #586 from the "Inch Up" switch. If the problem is resolved check the switch and associated leads. See wiring diagram.</li> <li>4. Check lights 7B, 7J and 7E. They should all be OFF. If lights 7B and 7J are OFF and light 7E is ON the logic board may be faulty. See <b>Figure F.1.</b></li> <li>5. Disconnect plug "A" from the logic board. If the wire feed stops the logic board may be faulty. See <b>Figure F.1.</b></li> <li>6. If the feed does not stop with plug "A" disconnected, disconnect plug "E" from the logic board. If the wire feed stops with plug "E" disconnected the logic board may be faulty. If the wire feed does NOT stop with plug "E" disconnected the power board may be faulty. Replace. See <b>Figure F.1.</b></li> </ol>

**⚠ CAUTION**

If for any reason you do not understand the test procedures or are unable to perform the tests/repairs safely, contact the Lincoln Electric Service Department before you proceed.

Return to Section TOC

Return to Master TOC

Return to Section TOC

Return to Master TOC

Return to Section TOC

Return to Master TOC

Return to Section TOC

Return to Master TOC

Observe all Safety Guidelines detailed throughout this manual

PROBLEMS (SYMPTOMS)	POSSIBLE AREAS OF MISADJUSTMENTS(S)	RECOMMENDED COURSE OF ACTION
<b>WIRE FEEDING PROBLEMS</b>		
<p>The wire does not feed. Pressing any of the switches (buttons) will NOT feed the wire. The motor does NOT run.</p>	<ol style="list-style-type: none"> <li>1. Make sure input power switch is ON.</li> <li>2. Check the circuit breaker (CB1). Reset if tripped.</li> <li>3. Make sure 115VAC is being applied to the control box through the control cable receptacle. Leads #31 and #32.</li> <li>4. Check the two fuses on the power board. Replace if blown. If fuse F101 immediately fails when replaced contact your local Lincoln Authorized Field Service Facility.</li> <li>5. Make sure the motor cable is connected to the motor receptacle on the NA-5 control box.</li> </ol>	<ol style="list-style-type: none"> <li>1. Check the lights (LEDS) locate on the PC boards. Some should be lit. See <b>Table F.1</b>. If none of the lights are lit perform the <b>T1 and T2 Transformer Test</b>.</li> <li>2. If the appropriate lights are lit (see <b>Table F.1</b>) and the wire does NOT feed perform the <b>Wire Drive Motor Test</b>.</li> <li>3. If only some of the appropriate lights on the power board are lit the power board may be faulty.</li> <li>4. If all of the appropriate lights are lit, except light 1D on the power board, check resistor R1. Normal resistance is 2 ohms. See wiring diagram.</li> <li>5. If fuse F101 immediately fails when input power is applied, unplug all of the PC boards except the power board. If the fuse still fails the power board may be faulty. If the fuse does not fail reconnect the PC boards one at a time until the faulty board is located. Also check and inspect the wiring harness for “short” or “grounds”. Reconnect the PC boards in the following order: control, voltage, logic, procedure, option, timer, remote interface, speedmeter and volt-meter.</li> </ol> <p>NOTE: Some of the above PC boards are optional and may not be used in all NA-5 control units.</p>

**⚠ CAUTION**

If for any reason you do not understand the test procedures or are unable to perform the tests/repairs safely, contact the Lincoln Electric Service Department before you proceed.

Return to Section TOC

Return to Master TOC

Return to Section TOC

Return to Master TOC

Return to Section TOC

Return to Master TOC

Return to Section TOC

Return to Master TOC

Observe all Safety Guidelines detailed throughout this manual

PROBLEMS (SYMPTOMS)	POSSIBLE AREAS OF MISADJUSTMENTS(S)	RECOMMENDED COURSE OF ACTION
WIRE FEEDING PROBLEMS		
<p>The wire will not feed and the circuit breaker (CB1) trips when the inch down, inch up or the start buttons are pressed. The wire drive motor does not turn.</p>	<ol style="list-style-type: none"> <li>1. Check for a mechanical restriction in the wire feeding path.</li> <li>2. Make sure the proper input voltage (115VAC) is applied to the NA-5 control unit.</li> <li>3. Check the F102 field fuse on the power board. Replace if faulty. Note: Frequent motor polarity changes can cause the fuse to fail. This can be caused by the following:                             <ul style="list-style-type: none"> <li>•A welding procedure with frequent electrode to puddle shorting.</li> <li>•A power source output too low to establish an arc.</li> </ul> </li> </ol>	<ol style="list-style-type: none"> <li>1. Perform the <b>Wire Drive Motor Test</b>.</li> <li>2. The power board may be faulty. See <b>Table F.1</b>.</li> <li>3. Check the motor control cable for “shorts’ or “grounds”.</li> </ol>
<p>When the inch up button is pressed the wire feeds down. When the inch down button is pressed the wire feeds up.</p>	<ol style="list-style-type: none"> <li>1. The welding head is designed to feed wire in the proper direction when it is installed as shipped from the factory. If the nozzle and wire straightener are rotated about the axis of the gearbox output shaft, the wire may feed in the opposite direction. Interchange leads #626 and #627 at the terminal strip (TS2) inside the control box. See wiring diagram.</li> </ol>	

⚠ CAUTION

If for any reason you do not understand the test procedures or are unable to perform the tests/repairs safely, contact the Lincoln Electric Service Department before you proceed.

Return to Section TOC

Return to Master TOC

Return to Section TOC

Return to Master TOC

Return to Section TOC

Return to Master TOC

Return to Section TOC

Return to Master TOC

Observe all Safety Guidelines detailed throughout this manual

PROBLEMS (SYMPTOMS)	POSSIBLE AREAS OF MISADJUSTMENTS(S)	RECOMMENDED COURSE OF ACTION
WIRE FEEDING PROBLEMS		
<p>The wire will not feed when the inch down button is pressed. The wire does inch up OK and feeds down when the start button is pressed.</p>	<ol style="list-style-type: none"> <li>1. If a DC400, Pulse Power 500 or a CV400 power source is used a Diode Kit must be installed in the power source.</li> <li>2. Check to see if light 7J on the logic board is ON while the inch down button is pressed. If it does NOT light check the inch down button and associated leads. See wiring diagram.                             <ul style="list-style-type: none"> <li>•(For codes below 8300) If light 7J DOES light when the inch down button is pressed the logic board may be faulty.</li> <li>•(For codes above 8300) Jumper the AUTO tabs on the voltage board and press inch down button. If the wire does NOT feed down the logic board may be faulty.</li> </ul> </li> </ol>	<ol style="list-style-type: none"> <li>1. Disconnect the white #21 lead from the NA-5 polarity terminal strip (TS1). See wiring diagram. With the inch down button pressed read the ACTUAL volts on the NA-5 digital voltmeter. The digital meter should read over 19 volts and the wire should inch down. If not, perform the <b>Voltage Board Transformer Test</b>. If the test is OK the voltage board may be faulty. Replace.</li> <li>2. If the voltage is over 19 volts and the wire DOES inch down with the #21 lead disconnected reconnect the #21 lead to the terminal strip and read the ACTUAL volts with the inch down button pressed. If the voltage is less than 8 volts perform the <b>#21 - #67 External Resistance Test</b>. If the resistance test is OK the voltage board may be faulty. Replace.</li> </ol>

⚠ CAUTION

If for any reason you do not understand the test procedures or are unable to perform the tests/repairs safely, contact the Lincoln Electric Service Department before you proceed.

Return to Section TOC

Return to Master TOC

Return to Section TOC

Return to Master TOC

Return to Section TOC

Return to Master TOC

Return to Section TOC

Return to Master TOC

Observe all Safety Guidelines detailed throughout this manual

PROBLEMS (SYMPTOMS)	POSSIBLE AREAS OF MISADJUSTMENTS(S)	RECOMMENDED COURSE OF ACTION
<b>WIRE FEEDING PROBLEMS</b>		
<p>The wire will not inch down but does inch up properly. The wire does not feed in either direction when the start button is pressed.</p>	<ol style="list-style-type: none"> <li>1. Check to make sure that light 7J, on the logic board, is lit when the inch down button is pressed. If not check the inch down switch and associated leads. See wiring diagram.</li> <li>2. Check to make sure that light 7B, on the logic board, is lit when the start button is pressed. If not check the start button and associated leads. See wiring diagram.</li> </ol>	<ol style="list-style-type: none"> <li>1. The logic board may be faulty. Replace.</li> <li>2. The power board may be faulty. Replace.</li> </ol>
<p>The wire will not inch down but does inch up properly. When the start button is pressed the wire feeds up instead of down.</p>	<ol style="list-style-type: none"> <li>1. For codes below 8300 make sure the jumper plug is securely installed in the harness receptacle near the voltage board.</li> <li>2. Check to make sure light 7E, on the logic board, is on when the inch down button is pressed. If light 7E is ON the power board may be faulty.</li> <li>3. Check the 1/8 amp fuse on the voltage board . Replace if faulty.</li> </ol>	<ol style="list-style-type: none"> <li>1. Jumper the AUTO tabs on the voltage board. (Above code 8300) Press the inch down button. If the wire inches down the voltage board may be faulty. Replace.</li> </ol> <p>If the wire does NOT inch down the logic board may be faulty. Replace.</p>

**⚠ CAUTION**

If for any reason you do not understand the test procedures or are unable to perform the tests/repairs safely, contact the Lincoln Electric Service Department before you proceed.

Return to Section TOC

Return to Master TOC

Return to Section TOC

Return to Master TOC

Return to Section TOC

Return to Master TOC

Return to Section TOC

Return to Master TOC



Observe all Safety Guidelines detailed throughout this manual

PROBLEMS (SYMPTOMS)	POSSIBLE AREAS OF MISADJUSTMENTS(S)	RECOMMENDED COURSE OF ACTION
<b>WIRE FEEDING PROBLEMS</b>		
<p>NA-5 units above code 8300 with "cold starting". The wire feeds up instead of down when the start button is pressed. The wire inches up and down properly.</p>	<ol style="list-style-type: none"> <li>1. Make sure the electrode wire is fed into the welding tip.</li> <li>2. Check the 1/8 amp fuse on the voltage board. Replace if faulty.</li> <li>3. Make sure electrode polarity is correct and the same as the #67 and #21 leads at terminal strip (TS1). See wiring diagram.</li> <li>4. Make sure the welding power source is producing welding arc voltage.</li> </ol>	<ol style="list-style-type: none"> <li>1. Jumper the #2 and #4 leads at the Lincoln CV power source. Open circuit voltage should be present at both the power source and at the ACTUAL voltmeter reading on the NA-5. If open circuit voltage is present at the power source but NOT at the NA-5 ACTUAL voltmeter reading perform the <b>#21-#67 External resistance Test</b>.</li> <li>2. With the start button pressed light 7K should be lit. If it is not the logic board may be faulty.</li> <li>3. Check contactor relay 3CR. Leads #2 and #4 are closed by relay 3CR. Make sure the relay is functioning properly.</li> <li>4. Check the control cable between the power source and the NA-5 control unit. See wiring diagram.</li> </ol>

**⚠ CAUTION**

If for any reason you do not understand the test procedures or are unable to perform the tests/repairs safely, contact the Lincoln Electric Service Department before you proceed.

Return to Section TOC

Return to Master TOC

Return to Section TOC

Return to Master TOC

Return to Section TOC

Return to Master TOC

Return to Section TOC

Return to Master TOC

Observe all Safety Guidelines detailed throughout this manual

PROBLEMS (SYMPTOMS)	POSSIBLE AREAS OF MISADJUSTMENTS(S)	RECOMMENDED COURSE OF ACTION
<b>WIRE FEEDING PROBLEMS</b>		
<p>NA-5 units above code 8300 with "cold starting". While pressing the inch down button the wire does not stop when it touches the work.</p>	<ol style="list-style-type: none"> <li>1. Check the 1/8 amp fuse on the voltage board. Replace if faulty.</li> <li>2. While pressing the inch down button with the wire touching the work piece, observe light 7G on the logic board. If the light goes on but the wire does NOT stop feeding the logic board may be faulty.</li> </ol>	<ol style="list-style-type: none"> <li>1. Perform the <b>#21-#67 External Resistance Test</b>.</li> <li>2. Check the continuity of leads #667 and #621 to the voltage board. See wiring diagram.</li> <li>3. The logic board may be faulty.</li> <li>4. The voltage board may be faulty.</li> </ol>
<p>The wire will NOT inch up but does inch down and weld properly.</p>	<ol style="list-style-type: none"> <li>1. With the unit at idle (no buttons pressed) observe lights 1D, on the power board, and light 7E, on the logic board. 1D should be ON. 7E should be OFF.</li> <li>2. If 1D is OFF replace the power board.</li> <li>3. If 7E is ON replace the logic board.</li> </ol>	<ol style="list-style-type: none"> <li>1. Check the inch up switch (button) for proper operation. Also check associated leads for loose or faulty connections. See wiring diagram.</li> </ol>
<p>The wire feeds UP when either inch button is pressed.</p>	<ol style="list-style-type: none"> <li>1. While pressing the inch down button observe light 7E on the logic board. It should be ON.</li> <li>2. If light 7E is ON, while the inch down button is pressed, the power board may be faulty. Replace.</li> <li>3. If light 7E remains OFF, while the inch down button is pressed, the logic board may be faulty. Replace.</li> </ol>	<ol style="list-style-type: none"> <li>1. Check the inch up and inch down switches (buttons) for proper operation and wiring. See wiring diagram.</li> </ol>

**⚠ CAUTION**

If for any reason you do not understand the test procedures or are unable to perform the tests/repairs safely, contact the Lincoln Electric Service Department before you proceed.

Observe all Safety Guidelines detailed throughout this manual

PROBLEMS (SYMPTOMS)	POSSIBLE AREAS OF MISADJUSTMENTS(S)	RECOMMENDED COURSE OF ACTION
<b>WIRE FEEDING PROBLEMS</b>		
<p>The wire feeds down when either inch button is pressed.</p>	<ol style="list-style-type: none"> <li>1. With the unit at idle (no buttons pressed) observe light 7E on the logic board. It should be OFF.</li> <li>2. If light 7E is ON the logic board may be faulty. Replace.</li> <li>3. If light 7E is OFF the power board may be faulty. Replace.</li> </ol>	<ol style="list-style-type: none"> <li>1. Check the inch up and inch down switches (buttons) for proper operation and wiring. See wiring diagram.</li> </ol>

**⚠ CAUTION**

If for any reason you do not understand the test procedures or are unable to perform the tests/repairs safely, contact the Lincoln Electric Service Department before you proceed.

Return to Section TOC

Return to Master TOC

Return to Section TOC

Return to Master TOC

Return to Section TOC

Return to Master TOC

Return to Section TOC

Return to Master TOC

Observe all Safety Guidelines detailed throughout this manual

PROBLEMS (SYMPTOMS)	POSSIBLE AREAS OF MISADJUSTMENTS(S)	RECOMMENDED COURSE OF ACTION
<b>MODE FUNCTION PROBLEMS</b>		
<p>The speed and voltage controls do not function. All of the mode lights function properly.</p>	<ol style="list-style-type: none"> <li>1. Check lights 1A and 1B located on the power board. They should both be ON.</li> <li>2. If both lights 1A and 1B are ON the control board may be faulty. Replace.</li> </ol>	<ol style="list-style-type: none"> <li>1. If lights 1A and /or 1B are OFF perform the <b>DC Power Supply Test</b>.</li> <li>2. Perform the <b>T1 and T2 Transformer Test</b>.</li> <li>3. The power board may be faulty. Replace.</li> </ol>
<p>All the mode lights function properly. None of the speed controls operate properly.</p> <p>All the mode lights function properly. None of the voltage controls operate properly.</p>	<ol style="list-style-type: none"> <li>1. The control board may be faulty. Replace.</li> <li>1. The voltage board may be faulty. Replace.</li> </ol>	

**⚠ CAUTION**

If for any reason you do not understand the test procedures or are unable to perform the tests/repairs safely, contact the Lincoln Electric Service Department before you proceed.

Return to Section TOC  
Return to Section TOC  
Return to Section TOC  
Return to Section TOC  
Return to Section TOC

Return to Master TOC  
Return to Master TOC  
Return to Master TOC  
Return to Master TOC  
Return to Master TOC

Observe all Safety Guidelines detailed throughout this manual

PROBLEMS (SYMPTOMS)	POSSIBLE AREAS OF MISADJUSTMENTS(S)	RECOMMENDED COURSE OF ACTION
<b>MODE FUNCTION PROBLEMS</b>		
Only the strike mode functions, when the unit is at idle, regardless of the selector switch position.	<ol style="list-style-type: none"> <li>1. The logic board may be faulty. Replace.</li> <li>2. The procedure board may be faulty.</li> </ol>	
Only the strike mode functions while welding. The unit stays in the strike mode and does not progress through the welding sequence.	<ol style="list-style-type: none"> <li>1. While the unit is welding check light 7D on the logic board. It should be ON when welding current is present. If light 7D is ON the logic board may be faulty.</li> <li>3. If light 7D is NOT lit when weld current is present make sure the weld cables have been properly routed through the cable clamp on the left side of the control box.</li> </ol>	<ol style="list-style-type: none"> <li>1. If light 7D is NOT lit, when weld current is present, connect a jumper wire from terminal #528 to #500 on terminal strip TS1. See wiring diagram. If light 7D does light check the CR4 reed switch and associated leads and connections. See wiring diagram.</li> <li>2. If 7D does NOT light, with the jumper wire in place, check the #528 lead and the #500 lead between the TS1 terminal strip and the logic board. See wiring diagram.</li> <li>3. The logic board may be faulty. Replace.</li> </ol>
The strike light is OFF and neither strike control functions. The other mode lights work. The unit will not feed wire when the start button is pressed.	<ol style="list-style-type: none"> <li>1. Check light 7D on the logic board. If it is off the logic board may be faulty. Replace.</li> <li>2. If the start light is on all the time the start board (if used) may be faulty. Replace or install jumper plug in procedure board.</li> <li>3. If the crater light is on all the time the crater board (if used) may be faulty. Replace or install jumper plug in procedure board.</li> <li>4. If the weld light is on all the time the logic board may be faulty. Replace.</li> </ol>	<ol style="list-style-type: none"> <li>1. If light 7D is ON check the CR4 reed switch and associated leads. See wiring diagram.</li> </ol>

**⚠ CAUTION**

If for any reason you do not understand the test procedures or are unable to perform the tests/repairs safely, contact the Lincoln Electric Service Department before you proceed.

NA-5



Observe all Safety Guidelines detailed throughout this manual

PROBLEMS (SYMPTOMS)	POSSIBLE AREAS OF MISADJUSTMENTS(S)	RECOMMENDED COURSE OF ACTION
<b>MODE FUNCTION PROBLEMS</b>		
The strike light does not light. The strike controls (voltage and wire feed speed) do function normally.	1. The procedure board may be faulty. Replace.	
The strike light comes on but the strike controls (voltage and wire feed speed) do not function normally.	1. The procedure board may be faulty. Replace.	
The start light does not light. The start controls (voltage and wire feed speed) may or may not function normally. The NA-5 is at idle with the selector switch in the "Start" position.	1. Make sure the start option board is installed correctly. 2. The procedure board may be faulty. Replace.	1. Check the lead harness between the start option board and the procedure board for loose or faulty connections. See wiring diagram.
The start light is ON but the start controls (voltage and wire feed speed) do not function. The NA-5 is at idle with the selector switch in the "Start" position.	1. If no other mode lights are lit the start option board may be faulty. Replace. 2. If the strike light is also lit (along with the start light) the logic board may be faulty. 3. If the weld and or crater lights are also lit (along with the start light) the procedure board may be faulty.	1. Check the lead harness between the start option board and the procedure board for loose or faulty connections. See wiring diagram.

**⚠ CAUTION**

If for any reason you do not understand the test procedures or are unable to perform the tests/repairs safely, contact the Lincoln Electric Service Department before you proceed.

Return to Section TOC

Return to Master TOC

Return to Section TOC

Return to Master TOC

Return to Section TOC

Return to Master TOC

Return to Section TOC

Return to Master TOC

Observe all Safety Guidelines detailed throughout this manual

PROBLEMS (SYMPTOMS)	POSSIBLE AREAS OF MISADJUSTMENTS(S)	RECOMMENDED COURSE OF ACTION
<b>MODE FUNCTION PROBLEMS</b>		
<p>When the start button is pressed and the unit is welding, the start mode is skipped.</p>	<ol style="list-style-type: none"> <li>1. Make sure the start option is installed properly in the NA-5.</li> <li>2. Make sure the start timer is set for a time greater than zero seconds.</li> <li>3. If the weld light goes ON as soon as (but not before) the arc is struck and the start timer is set for a time greater than zero seconds, the start timer board may be faulty.</li> <li>4. If the weld light goes ON before the arc is struck replace the start option board with the jumper plug. If the weld light continues to go ON before the arc is struck the logic board may be faulty. Replace.</li> <li>5. With the jumper plug installed: If the weld light does NOT go ON until the arc is struck the start option board may be faulty.</li> </ol>	<ol style="list-style-type: none"> <li>1. Check the lead harness between the start option boards and the procedure board for loose or faulty connections. See wiring diagram.</li> </ol>

**⚠ CAUTION**

If for any reason you do not understand the test procedures or are unable to perform the tests/repairs safely, contact the Lincoln Electric Service Department before you proceed.

Return to Section TOC

Return to Master TOC

Return to Section TOC

Return to Master TOC

Return to Section TOC

Return to Master TOC

Return to Section TOC

Return to Master TOC



Observe all Safety Guidelines detailed throughout this manual

PROBLEMS (SYMPTOMS)	POSSIBLE AREAS OF MISADJUSTMENTS(S)	RECOMMENDED COURSE OF ACTION
<b>MODE FUNCTION PROBLEMS</b>		
<p>When welding the start timer does not time out. The unit stays in the start mode.</p>	<ol style="list-style-type: none"> <li>1. When the weld is stopped check to see if the crater (if used) or burnback timer is functioning properly. If the crater and or burnback timer IS functioning properly the start timer may be faulty.</li> <li>2. If the start, crater and burnback timers are not working properly the procedure board may be faulty.</li> </ol>	<ol style="list-style-type: none"> <li>1. Check the lead harness between the start option boards and the procedure board for loose or faulty connections. See wiring diagram.</li> </ol>
<p>The crater light does not light. The crater controls (voltage and wire feed speed) may or may not function. The NA-5 is at idle with the selector switch in the "Crater" position.</p>	<ol style="list-style-type: none"> <li>1. Make sure the crater option boards are installed correctly.</li> <li>2. The procedure board may be faulty. Replace.</li> </ol>	<ol style="list-style-type: none"> <li>1. Check the lead harness between the crater option boards and the procedure board for loose or faulty connections. See wiring diagram.</li> </ol>
<p>The crater light is ON but the crater controls (voltage and wire feed speed) do not function. The NA-5 is at idle with the selector switch in the "Crater" position.</p>	<ol style="list-style-type: none"> <li>1. If no other lights are lit the crater option board may be faulty. Replace.</li> <li>2. If the strike light is also lit (along with the crater light) the logic board may be faulty.</li> <li>3. If the weld and or start lights are also lit (along with the crater light) the procedure board may be faulty.</li> </ol>	<ol style="list-style-type: none"> <li>1. Check the lead harness between the crater option boards and the procedure board for loose or faulty connections. See wiring diagram.</li> </ol>

**⚠ CAUTION**

If for any reason you do not understand the test procedures or are unable to perform the tests/repairs safely, contact the Lincoln Electric Service Department before you proceed.

Return to Section TOC

Return to Section TOC

Return to Section TOC

Return to Section TOC

Return to Master TOC

Return to Master TOC

Return to Master TOC

Return to Master TOC

Observe all Safety Guidelines detailed throughout this manual

PROBLEMS (SYMPTOMS)	POSSIBLE AREAS OF MISADJUSTMENTS(S)	RECOMMENDED COURSE OF ACTION
<b>MODE FUNCTION PROBLEMS</b>		
<p>At the end of the weld the crater light does NOT light.</p>	<ol style="list-style-type: none"> <li>1. Make sure the crater option is installed properly in the NA-5.</li> <li>2. Make sure the crater timer is set for a time greater than zero seconds.</li> <li>3. The crater option and or timer board may be faulty. Replace.</li> <li>4. The logic board may be faulty.</li> </ol>	<ol style="list-style-type: none"> <li>1. Check the lead harness between the crater boards and the procedure board for loose or faulty connections. See wiring diagram.</li> </ol>
<p>At the end of the weld the crater timer does not time out. The unit stays in the crater mode.</p>	<ol style="list-style-type: none"> <li>1. Replace the crater option board with the jumper plug. Set the burnback timer for any time greater than zero seconds. If the unit then stops after the weld and burnback time, the crater timer board may be faulty. Replace.</li> <li>2. If the unit does not stop the procedure board may be faulty.</li> </ol>	<ol style="list-style-type: none"> <li>1. Check the lead harness between the crater boards and the procedure board for loose or faulty connections. See wiring diagram.</li> </ol>
<p>No burnback/retract occurs at the end of the weld.</p>	<ol style="list-style-type: none"> <li>1. Make sure the burnback timer is set for a time greater than zero ohms.</li> <li>2. Be sure the jumper leads or dip switches on the logic board are configured correctly for the burnback/retract desired. See wiring diagram.</li> <li>3. The burnback timer module may be faulty. Replace.</li> <li>4. The procedure board may be faulty.</li> </ol>	<ol style="list-style-type: none"> <li>1. Check the lead harness between the burnback module and the procedure board for loose or faulty connections.</li> </ol>

**⚠ CAUTION**

If for any reason you do not understand the test procedures or are unable to perform the tests/repairs safely, contact the Lincoln Electric Service Department before you proceed.

Observe all Safety Guidelines detailed throughout this manual

PROBLEMS (SYMPTOMS)	POSSIBLE AREAS OF MISADJUSTMENTS(S)	RECOMMENDED COURSE OF ACTION
<b>MODE FUNCTION PROBLEMS</b>		
<p>1. The burnback timer does not time out properly.</p>	<p>1. Test if the other timers (start, weld, crater) function properly. If they time out correctly the burnback module may be faulty. Replace.</p> <p>2. If the other timers (start, weld, crater) do NOT function correctly the procedure board may be faulty.</p>	<p>1. Check the lead harness between the burnback module and the procedure board for loose or faulty connections.</p>
<p>The weld light does not light. The weld controls (voltage and wire feed speed) may or may not function. The NA-5 is at idle with the selector switch in the "Weld" position.</p>	<p>1. The procedure board may be faulty. Replace.</p>	
<p>The weld light is ON but the weld controls (voltage and wire feed speed) do not function. The NA-5 is at idle with the selector switch in the "Weld" position.</p>	<p>1. If the option boards (start and crater) are not installed make sure the jumper plugs are installed in the procedure board.</p> <p>2. If the strike light is also lit (along with the weld light) the logic board may be faulty.</p> <p>3. The procedure board may be faulty. Replace.</p>	

**⚠ CAUTION**

If for any reason you do not understand the test procedures or are unable to perform the tests/repairs safely, contact the Lincoln Electric Service Department before you proceed.

Return to Section TOC

Return to Master TOC

Return to Section TOC

Return to Master TOC

Return to Section TOC

Return to Master TOC

Return to Section TOC

Return to Master TOC

Observe all Safety Guidelines detailed throughout this manual

PROBLEMS (SYMPTOMS)	POSSIBLE AREAS OF MISADJUSTMENTS(S)	RECOMMENDED COURSE OF ACTION
<b>MODE FUNCTION PROBLEMS</b>		
<p>During the welding sequence the weld light does not go ON.</p>	<ol style="list-style-type: none"> <li>1. If the optional start timer is installed determine if the start mode is timing out. If the sequence stays in the “start” mode the start timer may be faulty.</li> <li>2. If the start module is OK and the weld light does not go ON the logic board may be faulty. Replace.</li> <li>3. If a start module is NOT used make sure the jumper plug is installed in the procedure board receptacle.</li> </ol>	
<p>While welding the weld mode is omitted in the welding sequence. The weld timer is set for a longer time than zero seconds.</p>	<ol style="list-style-type: none"> <li>1. The weld timer module may be faulty. Replace.</li> </ol>	<ol style="list-style-type: none"> <li>1. Check the lead harness between the weld timer and the procedure board for loose or faulty connections.</li> </ol>
<p>The weld timer does not time out. the unit stays in the weld mode.</p>	<ol style="list-style-type: none"> <li>1. Set the burnback timer for a value greater than zero seconds. Start the weld sequence and then stop it with the stop button. Check to see if the unit returns to the normal idle state.(Strike light ON and “Hot Electrode” light OFF).                             <ul style="list-style-type: none"> <li>• If the weld mode ends and the unit returns to the normal idle state, the weld timer module may be faulty.</li> <li>• If the unit does NOT return to the normal idle state the procedure board may be faulty.</li> </ul> </li> </ol>	<ol style="list-style-type: none"> <li>1. Check the lead harness between the weld timer and the procedure board for loose or faulty connections.</li> </ol>

**⚠ CAUTION**

If for any reason you do not understand the test procedures or are unable to perform the tests/repairs safely, contact the Lincoln Electric Service Department before you proceed.

Return to Section TOC  
Return to Section TOC  
Return to Section TOC  
Return to Section TOC

Return to Master TOC  
Return to Master TOC  
Return to Master TOC  
Return to Master TOC

Observe all Safety Guidelines detailed throughout this manual

PROBLEMS (SYMPTOMS)	POSSIBLE AREAS OF MISADJUSTMENTS(S)	RECOMMENDED COURSE OF ACTION
<b>FUNCTION PROBLEMS</b>		
<p>The start button does not initiate the power source output or the wire feed. The mode selector switch is in the strike position and the mode strike light is lit.</p>	<ol style="list-style-type: none"> <li>1. If the crater and or start option boards are NOT used the jumper plugs must be installed in the procedure board receptacles.</li> <li>2. With the unit at idle check light 7C on the logic board. It should be OFF. Also check light 7B on the logic board. With the start button pressed light 7B should go ON. If lights 7C and 7B are functioning normally the logic board may be faulty.</li> </ol>	<ol style="list-style-type: none"> <li>1. If light 7C is ON check the stop button and associated leads for “shorts” or “grounds”. Light 7C should be on ONLY when the stop button is pressed.</li> <li>2. If light 7B does NOT go on, when the start button is pressed, check the start switch (button) and associated leads for loose or faulty connections. See wiring diagram.</li> <li>3. Check the lead harness between the logic board and the procedure board for loose or faulty connections. See wiring diagram.</li> </ol>
<p>The start button initiates the power source output, but the wire does not feed.</p>	<ol style="list-style-type: none"> <li>1. If the wire inches up properly, but does not feed when the start button is pressed, the logic board may be faulty.</li> <li>2. If the wire does NOT feed, when the inch up button is pressed, check light 1E on the power board. It should go ON when the inch up button is pressed. If light 1E does not go on when the inch up button is pressed the control board may be faulty.</li> <li>3. The power board may be faulty.</li> </ol>	<ol style="list-style-type: none"> <li>1. If the wire does not feed when the inch up button is pressed perform the <b>Wire Drive Motor Test</b>.</li> </ol>

**⚠ CAUTION**

If for any reason you do not understand the test procedures or are unable to perform the tests/repairs safely, contact the Lincoln Electric Service Department before you proceed.

Return to Section TOC

Return to Master TOC

Return to Section TOC

Return to Master TOC

Return to Section TOC

Return to Master TOC

Return to Section TOC

Return to Master TOC

Observe all Safety Guidelines detailed throughout this manual

PROBLEMS (SYMPTOMS)	POSSIBLE AREAS OF MISADJUSTMENTS(S)	RECOMMENDED COURSE OF ACTION
<b>FUNCTION PROBLEMS</b>		
<p>The start button initiates the wire feed, but does not activate the power source output.</p>	<ol style="list-style-type: none"> <li>1. Make sure that lead #690 is connected to the proper pin on the logic board. On newer logic boards the dip switches must be in the proper position. See wiring diagram.</li> <li>2. Make sure the power source is capable of producing welding output voltage. Jumper #2 and #4 at the power source's terminal strip. This should produce open circuit voltage at the output terminals. If open circuit voltage is not present the power source may be faulty.</li> <li>3. Check or replace the control cable between the NA-5 and the power source.</li> <li>4. With the start button pressed check light 7K on the logic board and the "Electrode Hot" light. Both lights should be on. If the lights are OFF unplug the burnback timer. If the problem is resolved the burnback timer may be faulty. Replace.</li> <li>5. The logic board may be faulty.</li> </ol>	<ol style="list-style-type: none"> <li>1. The CR3 relay may be faulty. Check or replace.</li> <li>2. Check the #2 and #4 leads between the CR3 relay and the control cable receptacle. See wiring diagram.</li> </ol>

**⚠ CAUTION**

If for any reason you do not understand the test procedures or are unable to perform the tests/repairs safely, contact the Lincoln Electric Service Department before you proceed.

Return to Section TOC

Return to Master TOC

Return to Section TOC

Return to Master TOC

Return to Section TOC

Return to Master TOC

Return to Section TOC

Return to Master TOC

Observe all Safety Guidelines detailed throughout this manual

PROBLEMS (SYMPTOMS)	POSSIBLE AREAS OF MISADJUSTMENTS(S)	RECOMMENDED COURSE OF ACTION
<b>TRAVEL FUNCTION PROBLEMS</b>		
<p>The travel function will not operate regardless of the travel switch position.</p>	<ol style="list-style-type: none"> <li>1. Check the travel switch for proper operation. Also check associated leads for loose or faulty connections.</li> <li>2. Check the travel receptacle and associated leads for loose or faulty connections.</li> <li>3. Make sure the travel unit is operational.</li> </ol>	<ol style="list-style-type: none"> <li>1. With the travel switch (S2) in the hand travel position, and the 115VAC input power applied to the NA-5 unit, check for 115VAC at the travel receptacle. 115VAC should be present at leads #531 to #532. 115VAC should also be present at leads #25 to #531. If either of these two voltages are missing or not correct check the lead harness, switch (S2) and travel receptacle for loose or faulty connections. See wiring diagram.</li> <li>2. If the above voltages are correct the problem is in the travel unit or connecting cable.</li> </ol>
<p>The travel will not function with the travel switch in the "Hand" travel position. The unit operates properly with the travel switch in the "Auto" position.</p>	<ol style="list-style-type: none"> <li>1. Check the travel switch and associated leads for loose or faulty connections.</li> </ol>	<ol style="list-style-type: none"> <li>1. The travel switch may be faulty. Check or replace.</li> </ol>

**⚠ CAUTION**

If for any reason you do not understand the test procedures or are unable to perform the tests/repairs safely, contact the Lincoln Electric Service Department before you proceed.

Return to Section TOC

Return to Master TOC

Return to Section TOC

Return to Master TOC

Return to Section TOC

Return to Master TOC

Return to Section TOC

Return to Master TOC



Observe all Safety Guidelines detailed throughout this manual

PROBLEMS (SYMPTOMS)	POSSIBLE AREAS OF MISADJUSTMENTS(S)	RECOMMENDED COURSE OF ACTION
<b>TRAVEL FUNCTION PROBLEMS</b>		
<p>The travel will not function with the travel switch in the "Auto" position. The travel operates correctly with the travel switch in the "Hand" position.</p>	<ol style="list-style-type: none"> <li>1. Make sure the jumper leads #691 and #692 are connected properly to the correct pins on the logic board. See wiring diagram.</li> <li>2. Check the travel switch (S2) and associated leads for loose or faulty connections. See wiring diagram.</li> <li>3. Check light 7H located on the logic board. This light should be ON when the "Auto" travel is active. If light 7H does not light the logic board may be faulty.</li> </ol>	<ol style="list-style-type: none"> <li>1. If light 7H, located on the logic board, does light when the automatic travel is active check the CR2 relay. Normal coil resistance is 10,000 ohms. The contacts (terminals 2 and 4) should "close" when 110VDC is applied to the relay coil (terminals 1 + and 3 -).</li> </ol>
<p>The travel runs continuously when the travel switch is in the "Auto" position.</p>	<ol style="list-style-type: none"> <li>1. Make sure the jumper leads #691 and #692 are connected properly to the correct pins on the logic board. See wiring diagram.</li> <li>2. Check light 7H on the logic board. If light 7H is always ON the logic board may be faulty.</li> </ol>	<ol style="list-style-type: none"> <li>1. The 2CR relay may be faulty. The contacts (terminals 2 and 4) may be stuck closed.</li> <li>2. Check the associated leads for misconnections. See wiring diagram.</li> </ol>

**⚠ CAUTION**

If for any reason you do not understand the test procedures or are unable to perform the tests/repairs safely, contact the Lincoln Electric Service Department before you proceed.

Return to Section TOC

Return to Master TOC

Return to Section TOC

Return to Master TOC

Return to Section TOC

Return to Master TOC

Return to Section TOC

Return to Master TOC

Observe all Safety Guidelines detailed throughout this manual

PROBLEMS (SYMPTOMS)	POSSIBLE AREAS OF MISADJUSTMENTS(S)	RECOMMENDED COURSE OF ACTION
<b>FUNCTION PROBLEMS</b>		
<p>After pressing the stop button, the electrode "Hot" light goes OFF, but the electrode wire remains electrically hot. (The welding voltage is always present). The wire stops feeding.</p>	<ol style="list-style-type: none"> <li>Carefully disconnect the #2 lead from the power source terminal strip. The welding voltage should be disabled. If the welding voltage is still present the power source is faulty.</li> <li>Check or replace the control cable between the power source and the NA-5 unit.</li> </ol>	<ol style="list-style-type: none"> <li>The 3CR relay may be faulty. The contacts (terminals 2 and 4) may be stuck closed.</li> <li>Check the associated leads for misconnections. See wiring diagram.</li> </ol>
<p>After pressing the stop button, the weld light remains on and the wire continues to feed.</p>	<ol style="list-style-type: none"> <li>If a crater option module is used, check to make sure the logic board jumper (#694) is on pin P10.</li> <li>While pressing the stop button observe light 7C located on the logic board. It should be lit. If light 7C is ON and the wire feeding and welding does not stop, the logic board may be faulty.</li> </ol>	<ol style="list-style-type: none"> <li>If, while pressing the stop button, light 7C does NOT go on, check the stop button and associated leads.</li> </ol>
<p>The set and actual speed meter readings match within a few IPM, but both are in error.</p>	<ol style="list-style-type: none"> <li>Made sure the calibration jumper on the speedmeter board is connected properly. See <b>Operation Section</b>.</li> </ol>	<ol style="list-style-type: none"> <li>Remove the drive motor end cap and the tach cover plate from the end of the wire drive motor. Check to make sure the slotted disc is secure and aligned and rotates freely through the center of the module pick-up.</li> <li>Perform the <b>Wire Speed Accuracy Test</b></li> <li>Perform the <b>Meter Circuit Accuracy Test</b>.</li> <li>The control board may be faulty. Replace.</li> </ol>

**⚠ CAUTION**

If for any reason you do not understand the test procedures or are unable to perform the tests/repairs safely, contact the Lincoln Electric Service Department before you proceed.

Observe all Safety Guidelines detailed throughout this manual

PROBLEMS (SYMPTOMS)	POSSIBLE AREAS OF MISADJUSTMENTS(S)	RECOMMENDED COURSE OF ACTION
<b>FUNCTION PROBLEMS</b>		
<p>The set speed and actual speed meter readings do not match within a few IPM. One or both readings may be erratic.</p>	<p>1. Contact your local Lincoln Authorized Field Service Facility.</p>	<p>1. Check the lead and switch continuity of the SET speedmeter circuit. See wiring diagram.</p> <p>2. Check the lead and switch continuity of the ACTUAL speedmeter circuit. See wiring diagram.</p> <p>3. Perform the <b>Wire Speed Accuracy Test</b></p> <p>4. Perform the <b>Meter Circuit Accuracy Test.</b></p> <p>5. The control board may be fault</p>
<p>The set speed is adjustable and steady. The actual speed is uncontrollable. The meter displays the actual speed correctly.</p>	<p>1. Contact your local Lincoln Authorized Field Service Facility.</p>	<p>1. While the motor is running carefully unplug the 15 pin molex from the control board.</p> <p style="padding-left: 20px;">A. If the motor continues to run the power board may be faulty. Replace.</p> <p style="padding-left: 20px;">B. If the motor stops the control board may be faulty. Replace.</p> <p>2. Perform the <b>Wire Drive Motor Test.</b></p>

**⚠ CAUTION**

If for any reason you do not understand the test procedures or are unable to perform the tests/repairs safely, contact the Lincoln Electric Service Department before you proceed.

Return to Section TOC

Return to Master TOC

Return to Section TOC

Return to Master TOC

Return to Section TOC

Return to Master TOC

Return to Section TOC

Return to Master TOC

Observe all Safety Guidelines detailed throughout this manual

PROBLEMS (SYMPTOMS)	POSSIBLE AREAS OF MISADJUSTMENTS(S)	RECOMMENDED COURSE OF ACTION
<b>FUNCTION PROBLEMS</b>		
<p>The set speed is adjustable and steady. The actual speed reading is incorrect and or erratic.</p>	<ol style="list-style-type: none"> <li>1. Check that the jumper plug is installed securely in the harness receptacle near the voltage board. Codes below 8300 only.</li> <li>2. Check for loose or faulty connections on leads #510A, #525A and #555 between the tach receptacle and the control board.</li> <li>3. Check the tach cable from the tach board to the tach receptacle. The shield in the cable should NOT be grounded to the case.</li> </ol>	<ol style="list-style-type: none"> <li>1. Remove the drive motor end cap and the tach cover plate from the end of the wire drive motor. Check to make sure the slotted disc is secure and aligned and rotates freely through the center of the module pick-up.</li> <li>2. Perform the <b>Tach Board Feedback Test</b>.</li> <li>3. If the <b>Tach Board Feedback Test</b> is OK the control board may be faulty. Replace.</li> </ol>
<p>The set volts and actual volts readings match within a few tenths of a volt while welding. However both readings are inaccurate.</p>	<ol style="list-style-type: none"> <li>1. Put the Lincoln power source in the machine control mode. Check to see if the power supply can be set for the arc voltage required for the process. If not, the power source may be faulty.</li> <li>2. The control cable may be faulty. Check or replace.</li> </ol>	<ol style="list-style-type: none"> <li>1. Check the voltage sensing leads for continuity. (zero ohms). #21 should have continuity to the work piece and #67 should have continuity to the wire feed head assembly. See wiring diagram.</li> <li>2. Perform the <b>Voltmeter Accuracy Test</b>.</li> <li>3. Perform the <b>Meter Circuit Accuracy Test</b>.</li> <li>4. The voltage board may be faulty.</li> </ol>

**⚠ CAUTION**

If for any reason you do not understand the test procedures or are unable to perform the tests/repairs safely, contact the Lincoln Electric Service Department before you proceed.

Return to Section TOC

Return to Master TOC

Return to Section TOC

Return to Master TOC

Return to Section TOC

Return to Master TOC

Return to Section TOC

Return to Master TOC

Observe all Safety Guidelines detailed throughout this manual

PROBLEMS (SYMPTOMS)	POSSIBLE AREAS OF MISADJUSTMENTS(S)	RECOMMENDED COURSE OF ACTION
<b>FUNCTION PROBLEMS</b>		
<p>The actual volts reading does NOT match the set volts reading within a few tenths of a volt. One reading may be erratic. The NA-5 does not shut off.</p>	<ol style="list-style-type: none"> <li>1. NA-5 units with a G1556-2 (or higher) voltage board do not control the actual strike voltage to match the set strike voltage. The actual strike voltage is a function of the set strike voltage and the OCV control characteristics of the welding power source.  NA-5 controls with a G1556-3 (or higher) voltage board must have the jumper plug connected to the 4-cavity receptacle on the board, unless the pulsed power filter board option is connected.</li> <li>2. Make sure the shutdown "BYPASS" pins are not jumpered together on the NA-5 voltage board.</li> <li>3. Check the voltage sensing leads for continuity. (zero ohms). #21 lead should have continuity to the work piece and #67 lead should have continuity to the wire feed head assembly. See wiring diagram.</li> <li>4. Put the Lincoln welding power source in the machine control mode. Check to see if the power supply can be set for the arc voltage required for the process. If not, the power supply may be faulty.</li> </ol>	<ol style="list-style-type: none"> <li>1. If the actual reading is the problem check the actual volts switch and associated leads. See wiring diagram.</li> <li>2. If the set reading is the problem check the set volts switch and the associated leads. See wiring diagram.</li> <li>3. Perform the <b><i>Voltmeter Accuracy Test</i></b></li> <li>4. Perform the <b><i>Meter Circuit Accuracy Test</i></b>.</li> <li>5. The voltage board may be faulty.</li> </ol>

**⚠ CAUTION**

If for any reason you do not understand the test procedures or are unable to perform the tests/repairs safely, contact the Lincoln Electric Service Department before you proceed.

Return to Section TOC

Return to Master TOC

Return to Section TOC

Return to Master TOC

Return to Section TOC

Return to Master TOC

Return to Section TOC

Return to Master TOC

Observe all Safety Guidelines detailed throughout this manual

PROBLEMS (SYMPTOMS)	POSSIBLE AREAS OF MISADJUSTMENTS(S)	RECOMMENDED COURSE OF ACTION
<b>FUNCTION PROBLEMS</b>		
The NA-5 repeatedly shutdown while welding.	<ol style="list-style-type: none"> <li>1. Make sure the power source polarity switch is set for the correct electrode polarity.</li> <li>2. Make sure the #67 and #21 leads are connected to the TS1 terminal strip for the correct electrode polarity. See wiring diagram.</li> <li>3. Make certain the voltage control switch on the Lincoln CV power source is set in the "Remote" position.</li> <li>4. Make sure the #21 lead has continuity (zero ohms) to the work piece.</li> <li>5. Make sure the #67 lead has continuity (zero ohms) to the wire feed head assembly.</li> <li>6. Check the 1/8 amp fuse on the NA-5 voltage board. Replace if faulty.</li> <li>7. The control cable may be faulty. Check or replace.</li> <li>8. Be sure the welding power source is compatible with the NA-5.</li> </ol>	<ol style="list-style-type: none"> <li>1. Perform the <i><b>Out of Voltage Range Shutdown Test.</b></i></li> <li>2. The voltage board may be faulty.</li> </ol>

**⚠ CAUTION**

If for any reason you do not understand the test procedures or are unable to perform the tests/repairs safely, contact the Lincoln Electric Service Department before you proceed.

Return to Section TOC  
 Return to Section TOC  
 Return to Section TOC  
 Return to Section TOC  
 Return to Section TOC  
 Return to Section TOC

Return to Master TOC  
 Return to Master TOC  
 Return to Master TOC  
 Return to Master TOC  
 Return to Master TOC  
 Return to Master TOC

Observe all Safety Guidelines detailed throughout this manual

PROBLEMS (SYMPTOMS)	POSSIBLE AREAS OF MISADJUSTMENTS(S)	RECOMMENDED COURSE OF ACTION
<b>FUNCTION PROBLEMS</b>		
The circuit breaker trips when the inch up, inch down, or start buttons are pressed.	1. The power board may be faulty. Replace.	1. Perform the <i>Wire Drive Motor Test</i> .  2. Perform the <i>DC Power Supply Test</i> .
The circuit breaker trips and or the fuse (F101) blows when the NA-5 is turned on. (input power applied).	1. Contact your Local Lincoln Authorized Field Service Facility.	1. If fuse F101 or the circuit breaker immediately fails when input power is applied, unplug all of the PC boards except the power board. If the fuse still fails the power board may be faulty. If the fuse does not fail reconnect the PC boards one at a time until the faulty board is located. Also check and inspect the wiring harness for "short" or "grounds". Reconnect the PC boards in the following order: control, voltage, logic, procedure, option-timer, remote interface, speedmeter and voltmeter. NOTE: Some of the above PC boards are optional and may not be used in all NA-5 control units.

**⚠ CAUTION**

If for any reason you do not understand the test procedures or are unable to perform the tests/repairs safely, contact the Lincoln Electric Service Department before you proceed.

Return to Section TOC

Return to Master TOC

Return to Section TOC

Return to Master TOC

Return to Section TOC

Return to Master TOC

Return to Section TOC

Return to Master TOC



Observe all Safety Guidelines detailed throughout this manual

PROBLEMS (SYMPTOMS)	POSSIBLE AREAS OF MISADJUSTMENTS(S)	RECOMMENDED COURSE OF ACTION
<b>FUNCTION PROBLEMS</b>		
<p>The circuit breaker trips after the wire has been feeding for a period of time. Welding is normal.</p>	<p>1. Check to make sure there are not any mechanical restrictions in the wire feeding path which could cause excessive loading on the wire drive motor.</p>	<p>1. Perform the <i>DC Power Supply Test</i>.</p> <p>2. Perform the <i>Wire Drive Motor Test</i>.</p> <p>3. The power board may be faulty.</p>
<p>The 1/8 amp fuse on the voltage board repeatedly fails.</p>	<p>1. Check to make sure the PC boards are NOT grounded to the case of the NA-5. This can happen due to metallic dust build-up.</p>	<p>1. Remove the input power to the NA-5 and replace the 1/8 amp fuse. Locate and remove the #21 and #67 leads from the TS1 terminal strip.</p> <p style="padding-left: 20px;">A. Make a resistance check from the following leads to the NA-5 case grounding screw. Lead #510A, 510P, 500, 515 and 525.</p> <p style="padding-left: 20px;">B. The resistances should be above 1000 ohms. If any tests are below 1000 ohms that circuit has low resistance to case ground. Isolate faulty leads or PC board. See wiring diagram and schematic.</p>

**⚠ CAUTION**

If for any reason you do not understand the test procedures or are unable to perform the tests/repairs safely, contact the Lincoln Electric Service Department before you proceed.

Return to Section TOC

Return to Master TOC

Return to Section TOC

Return to Master TOC

Return to Section TOC

Return to Master TOC

Return to Section TOC

Return to Master TOC

Observe all Safety Guidelines detailed throughout this manual

PROBLEMS (SYMPTOMS)	POSSIBLE AREAS OF MISADJUSTMENTS(S)	RECOMMENDED COURSE OF ACTION
<b>STARTING/WELDING PROBLEMS</b>		
<p>The arc voltage appears to rise too slowly. The wire stubs or blasts off at the start of the weld sequence. Once the arc is established the welding is OK.</p>	<ol style="list-style-type: none"> <li>1. Increase the strike and or start voltage settings.</li> <li>2. Put the output control switch (on the power source) in the "Machine Control" position. Jumper the "BYPASS" pins on the NA-5 voltage board. Control the arc voltage from the power source. If the problem is NOT remedied the power source may be at fault. If the problem is solved the NA-5 may be at fault.</li> <li>3. If the start response jumper, on the voltage board, is in the "B" position, change to the "A" position. If the "A" position cures the starting problem the voltage board may be faulty.</li> </ol>	<ol style="list-style-type: none"> <li>1. The voltage board may be faulty. Replace.</li> </ol>
<p>The voltage seems too high or flares excessively at the start of the weld sequence. Once the arc is established the welding is OK.</p>	<ol style="list-style-type: none"> <li>1. Decrease the strike and or start voltage settings.</li> <li>2. Put the output control switch (on the power source) in the "Machine Control" position. Jumper the "BYPASS" pins on the voltage board. Control the arc voltage from the power source. If the problem is NOT remedied the power source may be at fault. If the problem is solved the NA-5 may be at fault.</li> </ol>	<ol style="list-style-type: none"> <li>1. The voltage board may be faulty. Replace.</li> </ol>

**⚠ CAUTION**

If for any reason you do not understand the test procedures or are unable to perform the tests/repairs safely, contact the Lincoln Electric Service Department before you proceed.

Observe all Safety Guidelines detailed throughout this manual

PROBLEMS (SYMPTOMS)	POSSIBLE AREAS OF MISADJUSTMENTS(S)	RECOMMENDED COURSE OF ACTION
<b>WELDING PROBLEMS</b>		
The arc is unstable or oscillating.	<ol style="list-style-type: none"> <li>1. Check the welding cables for loose or faulty connections.</li> <li>2. Make sure the electrode and gas (if used) is correct for the process being used.</li> <li>3. Put the output control switch (on the power source) in the "Machine Control" position. Jumper the "BYPASS " pins on the NA-5 voltage board. Control the arc voltage from the power source. If the problem is NOT remedied the power source may be at fault. If the problem is solved the NA-5 may be at fault.</li> </ol>	<ol style="list-style-type: none"> <li>1. The NA-5 voltage board may be faulty. Replace.</li> </ol>

**⚠ CAUTION**

If for any reason you do not understand the test procedures or are unable to perform the tests/repairs safely, contact the Lincoln Electric Service Department before you proceed.

Return to Section TOC  
 Return to Section TOC  
 Return to Section TOC  
 Return to Section TOC  
 Return to Section TOC  
 Return to Section TOC

Return to Master TOC  
 Return to Master TOC  
 Return to Master TOC  
 Return to Master TOC  
 Return to Master TOC  
 Return to Master TOC

Observe all Safety Guidelines detailed throughout this manual

PROBLEMS (SYMPTOMS)	POSSIBLE AREAS OF MISADJUSTMENTS(S)	RECOMMENDED COURSE OF ACTION
<b>FUNCTION PROBLEMS</b>		
The flux or gas/water solenoid does not function (open).	<ol style="list-style-type: none"> <li>1. Make sure the switch on the flux hopper is in the ON position.</li> <li>2. Check light 7G located on the logic board. This light should be on when the flux valve would normally be active. If light 7G does not light the logic board may be faulty.</li> </ol>	<ol style="list-style-type: none"> <li>1. If light 7G, located on the logic board, does light when the flux (gas/water) solenoid is normally active, check the CR1 relay. Normal coil resistance is 10,000 ohms. The contacts (terminals 2 and 4) should “close” when 110VDC is applied to the relay coil (terminals 1 + and 3 -).</li> <li>2. Check the wiring harness for loose or faulty connections between the CR1 relay, the logic board, the TS2 terminal strip and the flux receptacle. See wiring diagram.</li> </ol>
The flux or gas/water solenoid continuously remains open.	<ol style="list-style-type: none"> <li>1. Check light 7G located on the logic board. This light should be lit only when the flux valve would normally be active. If light 7G is lit continuously the logic board may be faulty.</li> <li>2. Check to make sure the solenoid is not stuck in the open position.</li> </ol>	<ol style="list-style-type: none"> <li>1. Check the CR1 relay. The contacts (terminal 2 and 4) should “close” only when 110VDC is applied to the relay coil. (terminals 1+ and 3-). If the contacts are “closed” continuously replace the CR1 relay.</li> </ol>

**⚠ CAUTION**

If for any reason you do not understand the test procedures or are unable to perform the tests/repairs safely, contact the Lincoln Electric Service Department before you proceed.

Return to Section TOC

Return to Master TOC

Return to Section TOC

Return to Master TOC

Return to Section TOC

Return to Master TOC

Return to Section TOC

Return to Master TOC

Observe all Safety Guidelines detailed throughout this manual

PROBLEMS (SYMPTOMS)	POSSIBLE AREAS OF MISADJUSTMENTS(S)	RECOMMENDED COURSE OF ACTION
<b>WELDING PROBLEMS</b>		
<p>The arc is unstable or oscillating.</p>	<ol style="list-style-type: none"> <li>1. Check the welding cables for loose or faulty connections.</li> <li>2. Make sure the electrode and gas (if used) is correct for the process being used.</li> <li>3. Put the Lincoln power source in the machine control mode. Jumper the "BYPASS" pins on the NA-5 voltage board. Adjust the weld voltage at the power source for the process being used. If the problem is NOT resolved the power source may be faulty.</li> </ol>	<ol style="list-style-type: none"> <li>1. The NA-5 voltage board may be faulty Replace.</li> </ol>
<p>The welding arc is variable or "hunting".</p>	<ol style="list-style-type: none"> <li>1. Make sure the welding parameters are correct for the welding procedure being used.</li> <li>2. Check the welding cables for loose or faulty connections.</li> <li>3. Check the wire feeding path for restrictions.</li> <li>4. The contact tip may be worn. Check or replace.</li> <li>5. The welding power source may be faulty. Check or replace.</li> </ol>	<ol style="list-style-type: none"> <li>1. Put the Lincoln power source in the machine control mode. Jumper the "BYPASS" pins on the NA-5 voltage board. Adjust the weld voltage at the power source for the process being used. If the problem is resolved check or replace the control cable or the NA-5 voltage board may be faulty.</li> <li>2. Perform the <b>Wire Drive Motor Test.</b></li> </ol>

**⚠ CAUTION**

If for any reason you do not understand the test procedures or are unable to perform the tests/repairs safely, contact the Lincoln Electric Service Department before you proceed.

Return to Section TOC

Return to Master TOC

Return to Section TOC

Return to Master TOC

Return to Section TOC

Return to Master TOC

Return to Section TOC

Return to Master TOC

Observe all Safety Guidelines detailed throughout this manual

PROBLEMS (SYMPTOMS)	POSSIBLE AREAS OF MISADJUSTMENTS(S)	RECOMMENDED COURSE OF ACTION
<b>WELDING PROBLEMS</b>		
<p>Poor arc striking with sticking or “blast offs”. The weld bead is ropey and has porosity.</p>	<ol style="list-style-type: none"> <li>1. Make sure the welding parameters (voltages and wire feed speed) and techniques are correct for the welding procedure being used.</li> <li>2. Check the welding cables for loose or faulty connections.</li> <li>3. The contact tip may be worn. Check or replace.</li> <li>4. The welding power source may be faulty. Check or replace.</li> </ol>	<ol style="list-style-type: none"> <li>1. Put the Lincoln power source in the machine control mode. Jumper the “BYPASS” pins on the NA-5 voltage board. Adjust the weld voltage at the power source for the process being used. If the problem is resolved check or replace the control cable or the NA-5 voltage board may be faulty.</li> </ol>

**⚠ CAUTION**

If for any reason you do not understand the test procedures or are unable to perform the tests/repairs safely, contact the Lincoln Electric Service Department before you proceed.

Return to Section TOC

Return to Master TOC

Return to Section TOC

Return to Master TOC

Return to Section TOC

Return to Master TOC

Return to Section TOC

Return to Master TOC

**PC BOARD LED (LIGHT) DEFINITIONS**

LED Number	Functions Indicated By PC Board LEDs
1A	+15VDC Analog Supply Present
1B	-10VDC Analog Supply Present
1C	Down Field Voltage Applied
1D	Up Field Voltage Applied
1E	Armature Voltage Applied
1F	115VDC Relay Supply Present
7A	+15VDC Logic Supply Present
7B	"Start" Switch Pressed
7C	"Stop" Switch Pressed
7D	Welding Current Present
7E	Signal to Apply Down Field Voltage
7G	Signal to Operate Flux or Water Solenoid
7H	Signal to Operate Travel Circuit
7J	"Inch Down" Switch Pressed
7K	Signal to Operate Power Source Output Contactor

LED LIGHT LOCATIONS

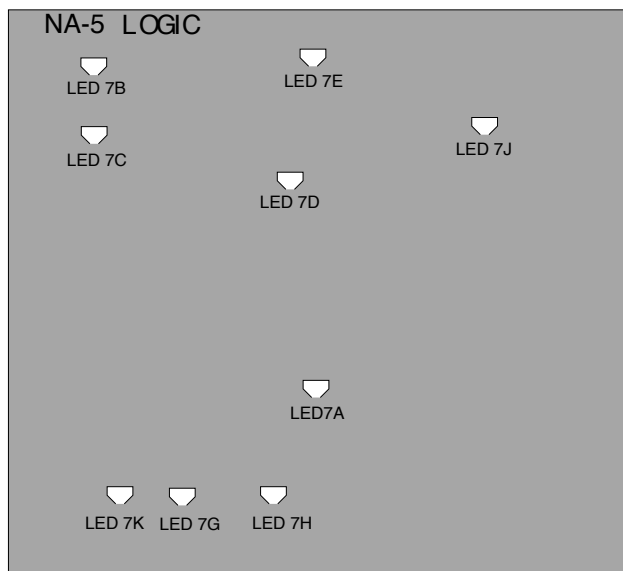

LED LIGHT LOCATIONS

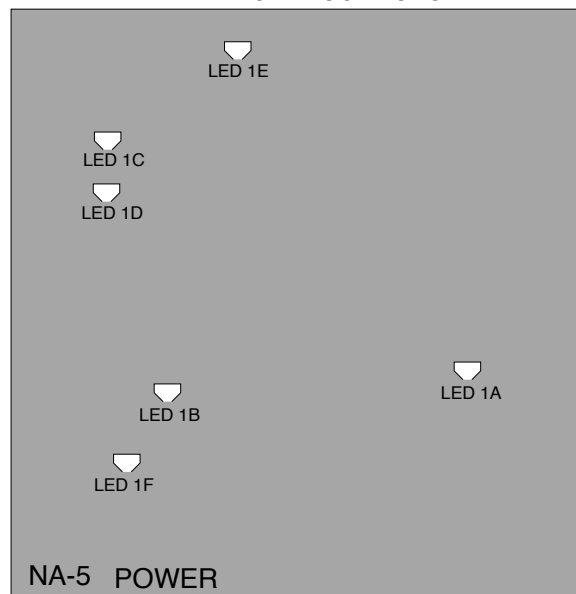



## PC BOARD LED (LIGHT) SEQUENCE TABLE ABOVE CODE 8300

INDICATOR LIGHTS			CONDITIONS FOR LIGHT "ON"					
Light No.	Location (PC Board)	Idle Mode	"Inch Up" Switch Pressed	"Inch Down" Switch Pressed	"Start" Switch Pressed	"Stop" Switch Pressed	Burnback Mode	Weld Arc Establish
1A	Power	ON	ON	ON	ON	ON	ON	ON
1B	Power	ON	ON	ON	ON	ON	ON	ON
1C	Power			ON	ON			ON
1D	Power	ON	ON			ON	ON	
1E	Power		ON	ON	ON			ON
1F	Power	ON	ON	ON	ON	ON	ON	ON
7A	Logic	ON	ON	ON	ON	ON	ON	ON
7B	Logic				ON*			
7C	Logic					ON*		
7D	Logic						ON	ON
7E	Logic			ON	ON			ON
7G	Logic			ON*	ON			ON
7H	Logic				ON**		ON**	ON
7J	Logic			ON*				
7K	Logic				ON		ON	ON

ON\* only while switch is pressed

ON\*\* dependent on travel mode

## DC POWER SUPPLY TEST

### WARNING

Service and repair should be performed only by Lincoln Electric factory trained personnel. Unauthorized repairs performed on this equipment could result in danger to the technician or the machine operator and will invalidate your factory warranty. For your safety and to avoid electrical shock, please observe all safety notes and precautions detailed throughout this manual.

If for any reason you do not understand the test procedures or are unable to perform the tests/repairs safely, contact the Lincoln Electric service department for technical troubleshooting assistance before you proceed.  
Call (216) 383-2531 or 1-888-935-3877.

### TEST DESCRIPTION

This will help determine if the power and logic boards are supplying the correct DC voltages to the NA-5 circuitry.

This procedure takes approximately 16 minutes to perform.

### MATERIALS NEEDED

5/16" Nutdriver  
Volt/Ohmmeter (Multimeter)  
Wiring diagram

## DC POWER SUPPLY TEST (continued)

## TEST PROCEDURE

1. Remove input power to the NA-5.
2. Using the 5/16" nutdriver open the control box PC board access door.
3. Locate the power, logic, voltage, control and procedure boards. See Figure F.1
4. Apply 115VAC to the NA-5 wire feeder at the correct pins. See wiring diagram.
5. Perform the power supply checks as described in Table F.1. If any of the readings are incorrect (out of range) or missing the power or logic board may be faulty. See wiring diagram. Note: Do not unplug the molex connectors.

**Also check associated leads and plugs for loose or faulty connections.**

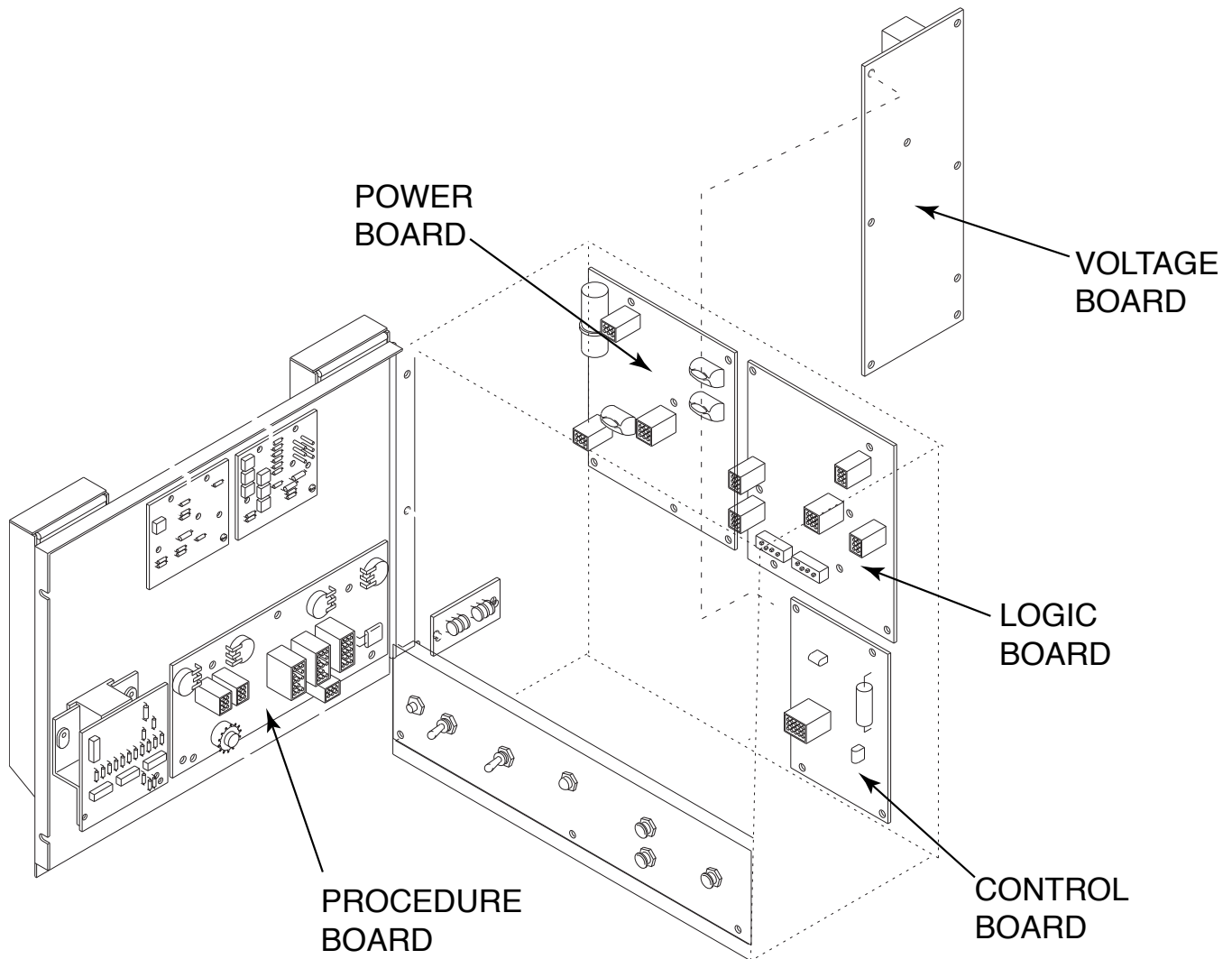
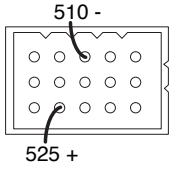
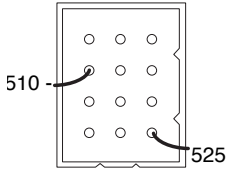
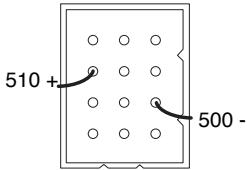
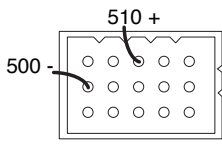
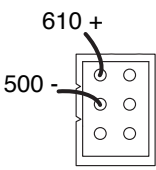

FIGURE F.1 P.C. BOARD LOCATIONS

## DC POWER SUPPLY TEST (continued)

TABLE F.1 DC POWER SUPPLY CHECKS

CHECK POINT LOCATION	TEST DESCRIPTION	CONNECTOR PLUG PIN NO.	LEAD NO.	NORMAL ACCEPTABLE VOLTAGE READING
CONTROL PC BOARD CONNECTOR PLUG	CHECK +15VDC SUPPLY FROM POWER BOARD TO CONTROL BOARD	PIN 10 + PIN 9 - 	525 + 510 -	14.0 - 16.0 VDC
VOLTAGE PC BOARD 12 PIN CONNECTOR PLUG	CHECK +15VDC SUPPLY FROM POWER BOARD TO VOLTAGE BOARD	PIN 3 + PIN 7 - 	525 + 510 -	14.0 - 16.0 VDC
VOLTAGE PC BOARD 12 PIN CONNECTOR PLUG	CHECK -10VDC SUPPLY FROM POWER BOARD TO VOLTAGE BOARD	PIN 6 - PIN 7 + 	500 - 510 +	9.0 - 11.0 VDC
CONTROL PC BOARD CONNECTOR PLUG	CHECK -10VDC SUPPLY FROM POWER BOARD TO CONTROL BOARD	PIN 14 - PIN 9 + 	500 - 510 +	9.0 - 11.0 VDC
LOGIC PC BOARD J1 CONNECTOR PLUG	CHECK +110VDC SUPPLY FROM POWER BOARD TO LOGIC BOARD	PLUG J1 PIN 1 + PLUG J1 PIN 2 - 	610 + 500 -	90 - 135 VDC

Return to Section TOC

Return to Section TOC

Return to Section TOC

Return to Section TOC

Return to Master TOC

Return to Master TOC

Return to Master TOC

Return to Master TOC

## DC POWER SUPPLY TEST (continued)

TABLE F.1 DC POWER SUPPLY CHECKS (continued)

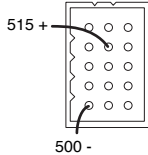
CHECK POINT LOCATION	TEST DESCRIPTION	CONNECTOR PLUG PIN NO.	LEAD NO.	NORMAL ACCEPTABLE VOLTAGE READING
PROCEDURE PC BOARD J19 CONNECTOR PLUG	CHECK +15VDC SUPPLY FROM LOGIC BOARD TO PROCEDURE BOARD	PLUG J19 PIN 5 +  PLUG J19 PIN 15 -  	515 +  500 -	14.0 - 16.0 VDC
VOLTMETER BOARD	CHECK +5VDC SUPPLY PRODUCED ON THE VOLTMETER BOARD	TEST POINT <sup>1</sup> : TP5 +  TEST POINT <sup>1</sup> : 510P -	TP5 +  LEAD 510P -	4.75 - 5.25 VDC
SPEEDMETER BOARD	CHECK +5VDC SUPPLY PRODUCED ON THE SPEEDMETER BOARD	TEST POINT <sup>1</sup> : TP5 +  TEST POINT <sup>1</sup> : 510P -	TP5 +  LEAD 510P -	4.75 - 5.25 VDC

<sup>1</sup>Scrape encapsulation from test points.

## T1 and T2 TRANSFORMER TEST

### WARNING

Service and repair should be performed only by Lincoln Electric factory trained personnel. Unauthorized repairs performed on this equipment could result in danger to the technician or the machine operator and will invalidate your factory warranty. For your safety and to avoid electrical shock, please observe all safety notes and precautions detailed throughout this manual.

If for any reason you do not understand the test procedures or are unable to perform the tests/repairs safely, contact the Lincoln Electric service department for technical troubleshooting assistance before you proceed.  
Call (216) 383-2531 or 1-888-935-3877.

### TEST DESCRIPTION

This test will help the technician to determine if the T1 and/or T2 transformers are functioning properly.

This procedure takes approximately 15 minutes to perform.

### MATERIALS NEEDED

115VAC power supply  
Volt-Ohmmeter (Multimeter)  
5/16" Nutdriver  
Slot head screwdriver

NA-5

 LINCOLN  
ELECTRIC

## T1 and T2 TRANSFORMER TEST (Continued)

### PROCEDURE

1. Remove all input power to the NA-5.
2. Using 5/16" nutdriver open the control box PC board access door.
3. Locate the T1 and T2 transformers. See Figure F.2
4. Locate and remove the two sets of primary leads (#531B and #532) from the upper terminal strip TS2. Label leads for reassembly. See wiring diagram and Figure F.2
5. Using the 115VAC supply carefully apply 115VAC to the T1 primary leads #531B and #532.
6. Check for approximately 10VAC at the yellow secondary leads (#601 and #602). See wiring diagram.

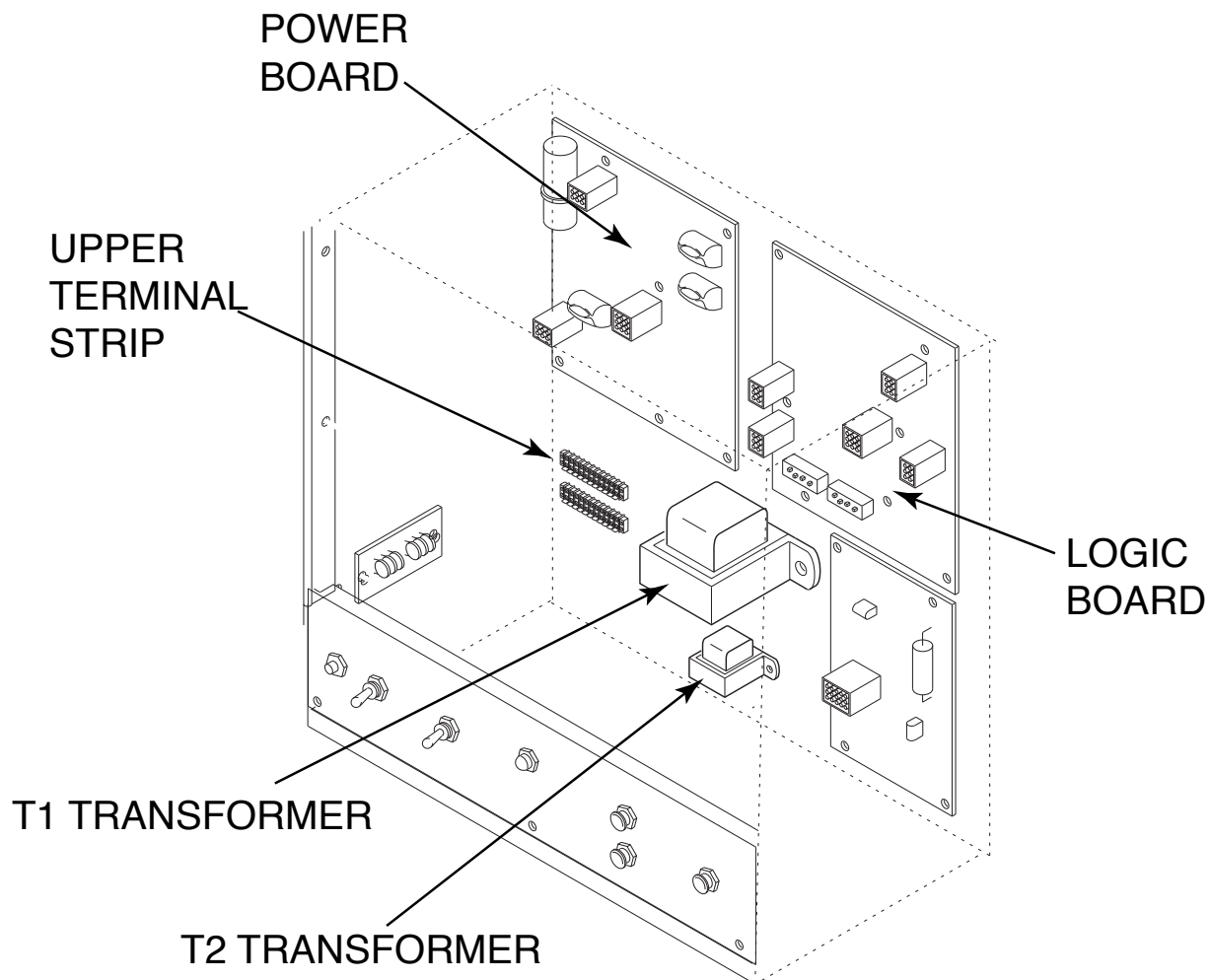

FIGURE F.2 T1 AND T2 TRANSFORMERS

**T1 and T2 TRANSFORMER TEST** (Continued)

7. Check for approximately 22VAC at the blue secondary leads. The blue secondary leads are connected to the logic board. See wiring diagram.
8. Check for approximately 18VAC at the white to red leads. The white and red leads are connected to the power board. See wiring diagram.
9. Check for approximately 36VAC at the red to red leads. Both red leads are also connected to the power board. See wiring diagram.
10. If all the secondary voltages are correct the T1 transformer is functioning properly.
11. If any or all of the secondary voltages are low or not present the T1 transformer may be faulty.
12. Using the 115VAC supply carefully apply 115VAC to the T2 primary leads #531B and #532.
13. Check for approximately 115VAC at the orange secondary leads. The orange leads are connected to the power board. See wiring diagram.
14. Check for approximately 24VAC at the brown secondary leads. See wiring diagram.
15. If all the secondary voltages are correct the T2 transformer is functioning properly.
16. If any or all of the secondary voltages are low or not present the T2 transformer may be faulty.
17. Reconnect the primary leads (#531B and #532) to the TS2 terminal strip.
18. Close and secure the access door.

Return to Section TOC

Return to Master TOC

Return to Section TOC

Return to Master TOC

Return to Section TOC

Return to Master TOC

Return to Section TOC

Return to Master TOC



## VOLTAGE BOARD TRANSFORMER TEST

### WARNING

Service and repair should be performed only by Lincoln Electric factory trained personnel. Unauthorized repairs performed on this equipment could result in danger to the technician or the machine operator and will invalidate your factory warranty. For your safety and to avoid electrical shock, please observe all safety notes and precautions detailed throughout this manual.

If for any reason you do not understand the test procedures or are unable to perform the tests/repairs safely, contact the Lincoln Electric service department for technical troubleshooting assistance before you proceed.  
Call (216) 383-2531 or 1-888-935-3877.

### TEST DESCRIPTION

This test will aid the technician in determining if the transformer on the voltage board is functioning properly.

This procedure takes approximately 15 minutes to perform.

### MATERIALS NEEDED

5/16" Nutdriver  
Phillips head screwdriver  
115VAC power supply  
Volt/Ohmmeter

## VOLTAGE BOARD TRANSFORMER TEST (Continued)

### TEST PROCEDURE

1. Remove all input power to the NA-5.
2. Using the 5/16" nutdriver open the control box PC board access door.
3. Locate the voltage board. See Figure F.3
4. Remove the molex type plugs from the voltage board.
5. Using the phillips head screwdriver remove the voltage board from the control box.
6. Locate the transformer and test points on the voltage board. See Figure F.4

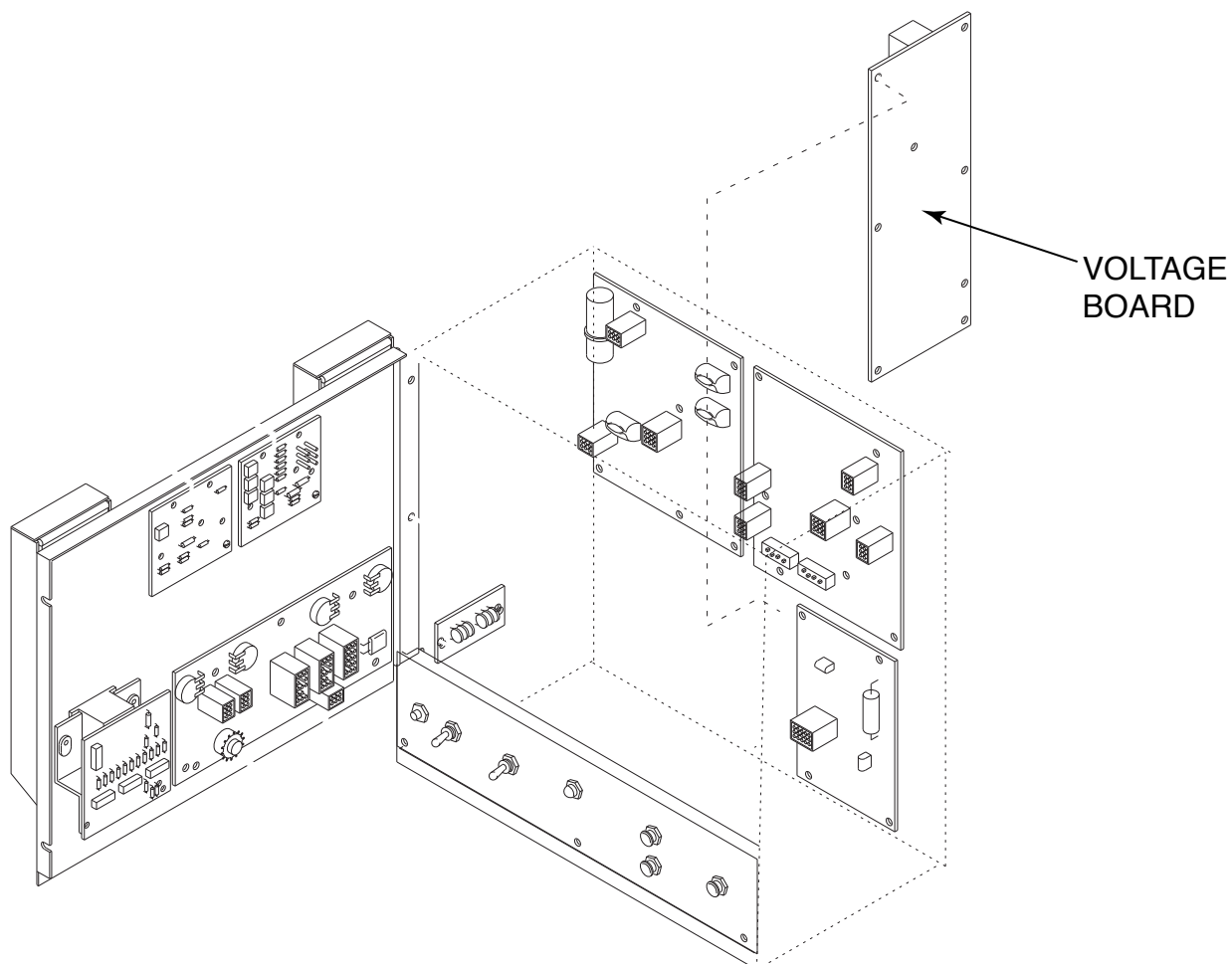

FIGURE F.3 VOLTAGE BOARD LOCATION

## VOLTAGE BOARD TRANSFORMER TEST (Continued)

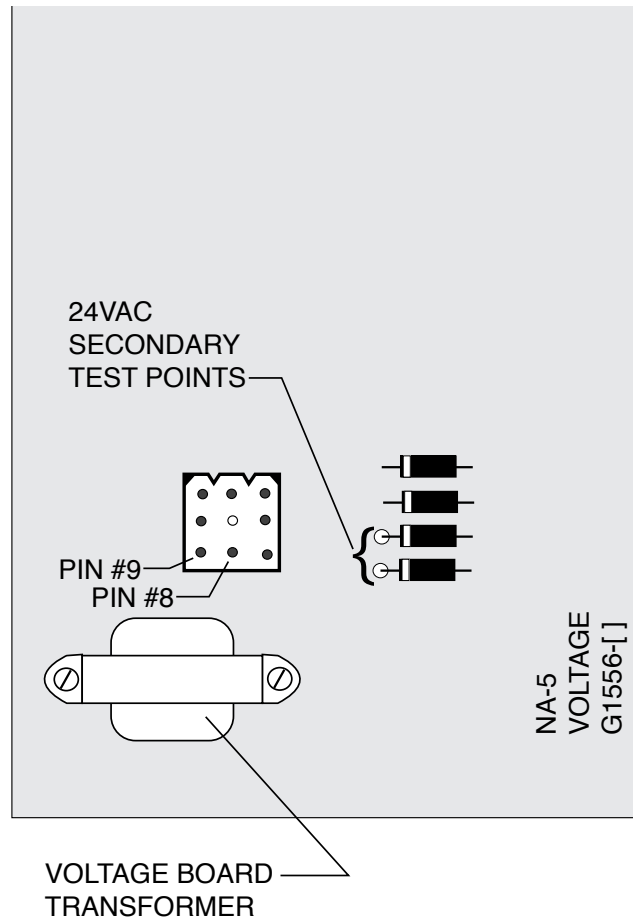

FIGURE F.4 TRANSFORMER TEST POINTS

7. Using the 115VAC supply carefully apply 115VAC to pins #8 and #9 in the nine pin molex plug cavity on the voltage board. See Figure F.4 Make sure the board and leads are insulated from each other and any metal conductors.
8. Using the voltmeter check for approximately 24VAC at the secondary test points. See Figure F.4
9. If the secondary voltage is correct the transformer is functioning properly.
10. If the secondary voltage is low or not present the transformer may be faulty.
11. Carefully remove the 115VAC supply from the voltage board.
12. Install the voltage board and connect the molex plugs.
13. Close and secure the access door.

Note: The secondary voltage will vary with the input primary voltage. The insulating material will have to be removed from the secondary test points to insure that the meter probes make good electrical contact.

## WIRE FEED DRIVE MOTOR TEST

**⚠ WARNING**

Service and repair should be performed only by Lincoln Electric factory trained personnel. Unauthorized repairs performed on this equipment could result in danger to the technician or the machine operator and will invalidate your factory warranty. For your safety and to avoid electrical shock, please observe all safety notes and precautions detailed throughout this manual.

If for any reason you do not understand the test procedures or are unable to perform the tests/repairs safely, contact the Lincoln Electric service department for technical troubleshooting assistance before you proceed.  
Call (216) 383-2531 or 1-888-935-3877.

**TEST DESCRIPTION**

This test will determine if the wire drive motor is able to function when supplied with the correct voltages..

This procedure takes approximately 17 minutes to perform.

**MATERIALS NEEDED**

Variable DC voltage supply 0 to 90 VDC  
Isolated DC voltage supply 0 to 120 VDC  
Volt/Ohmmeter

NA-5

**LINCOLN**  
ELECTRIC

## WIRE FEED DRIVE MOTOR TEST (Continued)

### TEST PROCEDURE

1. Remove the wire feed motor connector from the NA-5 control box.
2. Using the ohmmeter, measure the resistances per the table below. Also see Figure F.5.
3. If the motor resistance test is good, proceed to the **Motor Applied Voltage Test**.

### MOTOR APPLIED VOLTAGE TEST

1. Carefully connect the isolated 120 VDC supply (**SUPPLY TURNED OFF**) to pins C and D on the motor connector.
2. Carefully connect the variable 0 to 90 VDC supply (**SUPPLY TURNED OFF**) to pins A and B on the motor connector. (See **Table F.1**.)
3. Apply field voltage first (pins C and D) to the motor. Then, slowly apply the armature voltage to pins A and B. (See **Table F.1**.)
4. The motor should run, and the speed should vary with changes to the armature voltage.
5. If the motor does NOT run and change speed correctly, the motor or gear box may be faulty.
6. To stop the motor, **REMOVE THE ARMATURE VOLTAGE FIRST** (pins A and B).

**FIGURE F.5 WIRE FEED DRIVE MOTOR CONNECTOR PINS.**

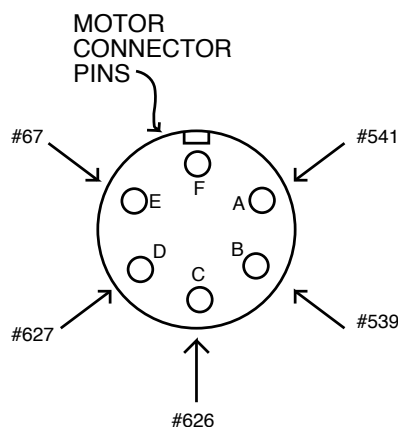

TEST POINTS	RESISTANCE	DC VOLTAGE
Lead #539 to lead #541 armature	4 to 5 ohms	0 to 90 VDC
Lead #626 to lead #627 field winding	750 to 850 ohms	90 to 120 VDC
All leads to motor shell (Except lead #67)	500,000 ohms min.	NONE
Lead #67 to motor shell	zero ohms	Not Applicable

Return to Section TOC  
 Return to Master TOC  
 Return to Section TOC  
 Return to Master TOC  
 Return to Section TOC  
 Return to Master TOC  
 Return to Section TOC  
 Return to Master TOC

## EXTERNAL RESISTANCE TEST (LEADS #21 AND #67)

### WARNING

Service and repair should be performed only by Lincoln Electric factory trained personnel. Unauthorized repairs performed on this equipment could result in danger to the technician or the machine operator and will invalidate your factory warranty. For your safety and to avoid electrical shock, please observe all safety notes and precautions detailed throughout this manual.

If for any reason you do not understand the test procedures or are unable to perform the tests/repairs safely, contact the Lincoln Electric service department for technical troubleshooting assistance before you proceed. Call (216) 383-2531 or 1-888-935-3877.

### TEST DESCRIPTION

This test will help the technician to determine if the external voltage sensing leads are connected properly and intact.

This procedure takes approximately 8 minutes to perform.

### MATERIALS NEEDED

Volt-Ohmmeter (Multimeter)  
5/16" Nutdriver  
3/4" wrench  
Wiring diagram

**EXTERNAL RESISTANCE TEST (LEADS #21 AND #67) (Continued)**

**PROCEDURE**

1. Make sure the electrode wire is fed through the wire contact assembly tip but NOT touching the "work" piece.
2. Disconnect input power to the NA-5.
3. Make sure the drive motor cable and power source control cables are properly connected to the NA-5 control box.
4. Using the 5/16" nutdriver open the control box PC board access door.
5. Locate the TS1 terminal strip. See wiring diagram.
6. Using the ohmmeter check the resistances per the following table F.2
7. Reconnect the welding cable leads to the contact assembly.
8. If any of the resistances are not correct per Table F.2 check the associated leads, cables and circuits for "opens" or "shorts". See wiring diagram.
9. Close and secure the control box access door.

**TABLE F.2 EXTERNAL VOLTAGE SENSING LEADS TEST POINTS**

TEST POINTS	EXPECTED RESISTANCES	COMMENTS AND CONDITIONS
Lead #667 to Electrode wire	Zero or less than 1 ohm	Electrode wire must be in contact assembly tip
Lead #621 to work piece	Zero or less than 1 ohm	Polarity switches must be in the correct positions
Lead #667 to #621	Greater than 15K ohms	Using the 3/4" wrench disconnect the welding cable(s) from the contact assembly

Return to Section TOC  
Return to Master TOC

## OUT OF VOLTAGE RANGE SHUT DOWN TEST

### WARNING

Service and repair should be performed only by Lincoln Electric factory trained personnel. Unauthorized repairs performed on this equipment could result in danger to the technician or the machine operator and will invalidate your factory warranty. For your safety and to avoid electrical shock, please observe all safety notes and precautions detailed throughout this manual.

If for any reason you do not understand the test procedures or are unable to perform the tests/repairs safely, contact the Lincoln Electric service department for technical troubleshooting assistance before you proceed.  
Call (216) 383-2531 or 1-888-935-3877.

### TEST DESCRIPTION

This test will help determine if the out-of-voltage range shut down circuitry is functioning properly.

This procedure takes approximately 18 minutes to perform.

### MATERIALS NEEDED

5/16" Nutdriver  
Jumper wire  
Lincoln CV Power Source

NA-5





## OUT OF VOLTAGE RANGE SHUT DOWN TEST (Continued)

### TEST PROCEDURE

1. Remove input power to the NA-5
2. Using the 5/16" nutdriver open the control box PC board access door.
3. Locate the voltage PC board. Jumper together the "BYPASS" and "Common" pins on the NA-5 voltage PC board. See Figure F.6 (On older voltage boards these pins may be labeled "B"). This should disable the shut down circuit.
4. Connect to a Lincoln Electric CV power source per connection diagram. See the *Installation section* of this manual.

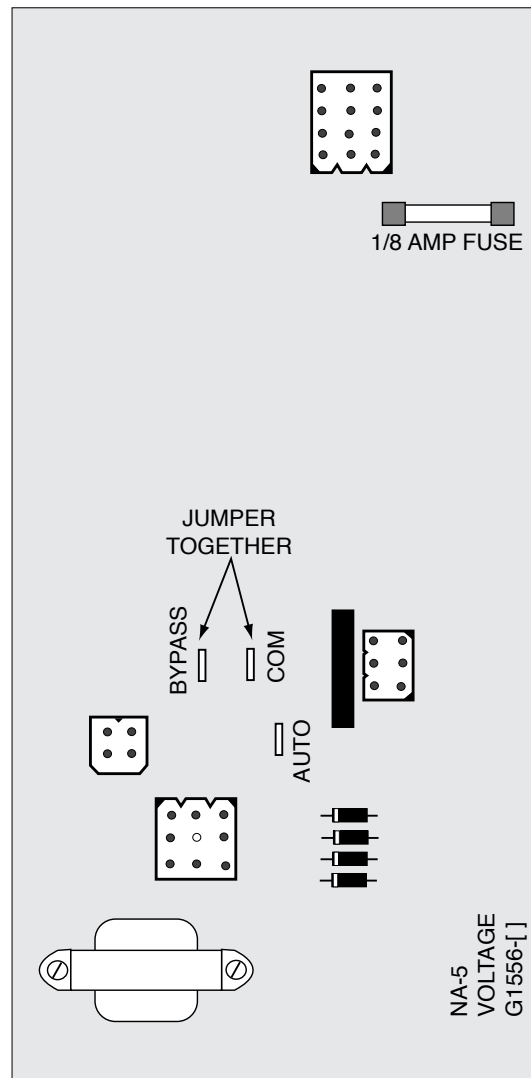

FIGURE F.6 VOLTAGE BOARD AND PIN LOCATIONS

## OUT OF VOLTAGE RANGE SHUT DOWN TEST (Continued)

5. Start welding and observe the ACTUAL voltage reading on the NA-5 digital meter. The actual voltage must match the SET voltage within +/- 0.5VDC. If it does NOT, the NA-5 is designed to shut down.
6. If the NA-5 continues to shut down with the "BYPASS" pins jumpered together, the voltage PC board may be faulty.
7. If the ACTUAL voltage reading is zero, the sensing leads may be faulty. Perform the **External Resistance Test**. Also check the 1/8 amp fuse on the voltage PC board.
8. Check the polarity switches in the Lincoln power source and its associated leads. Set the switches to the same polarity as the electrode. See the Wiring Diagram.
9. If the ACTUAL voltage reading is different from the SET voltage reading, the power source may not be capable of producing the required arc voltage, the control cable may be faulty or misconnected, or the NA-5 voltage PC board may be faulty.
10. After all tests are complete, remove the input power to the wire feeder and remove the jumper wire you placed on the "BYPASS" pins on the voltage PC board. Close and secure the access door.

Return to Section TOC

Return to Master TOC

Return to Section TOC

Return to Master TOC

Return to Section TOC

Return to Master TOC

Return to Section TOC

Return to Master TOC

## TACH BOARD FEEDBACK TEST

### WARNING

Service and repair should be performed only by Lincoln Electric factory trained personnel. Unauthorized repairs performed on this equipment could result in danger to the technician or the machine operator and will invalidate your factory warranty. For your safety and to avoid electrical shock, please observe all safety notes and precautions detailed throughout this manual.

If for any reason you do not understand the test procedures or are unable to perform the tests/repairs safely, contact the Lincoln Electric service department for technical troubleshooting assistance before you proceed.  
Call (216) 383-2531 or 1-888-935-3877.

### TEST DESCRIPTION

This procedure will aid the technician to determine if the tach board is functioning properly.

This procedure takes approximately 10 minutes to perform.

### MATERIALS NEEDED

5/16" Nutdriver  
Phillips head screwdriver  
Analog volt/ohmmeter (Multimeter)  
Wiring diagram

## TACH BOARD FEEDBACK TEST (Continued)

## PROCEDURE

1. Remove input power to the NA-5.
2. Using the 5/16" nutdriver open the control box PC board access door.
3. Locate leads #510A, #525A and #555 on the control board.
4. Apply 115VAC to the NA-5 wire feeder at the correct pins. See wiring diagram.
5. Check leads #525A(+) to #510A(-) for the presence of 15VDC. This is the supply voltage from the control PC board to the tach PC board. If the voltage is present, proceed to the next step. If the voltage is missing check the associated wiring and then perform the **DC Power Supply Test**.
6. With the motor running (activate either inch switches or the start switch) and check leads #555(+) to #510A(-) for the presence of between 4.5 - 10.5VDC. (The motor must be running.) This is the feedback voltage from the tach PC board to the control PC board. This voltage is dependent upon motor speed.
7. If the feedback voltage is missing or does not vary with motor speed, the tach PC board may be faulty. Also check for loose or faulty connections.
8. After the completion of the tests remove the 115VAC power and close and secure the access door.

Return to Section TOC  
Return to Master TOCReturn to Section TOC  
Return to Master TOCReturn to Section TOC  
Return to Master TOCReturn to Section TOC  
Return to Master TOC

## VOLTMETER ACCURACY TEST

### WARNING

Service and repair should be performed only by Lincoln Electric factory trained personnel. Unauthorized repairs performed on this equipment could result in danger to the technician or the machine operator and will invalidate your factory warranty. For your safety and to avoid electrical shock, please observe all safety notes and precautions detailed throughout this manual.

If for any reason you do not understand the test procedures or are unable to perform the tests/repairs safely, contact the Lincoln Electric service department for technical troubleshooting assistance before you proceed.  
Call (216) 383-2531 or 1-888-935-3877.

### TEST DESCRIPTION

This test will help determine if the NA-5 voltmeter is providing accurate readings.

This procedure takes approximately 10 minutes to perform.

### MATERIALS NEEDED

Digital volt/ohmmeter with at least 3-1/2 digits and +/-0.5% accuracy

## VOLTMETER ACCURACY TEST (Continued)

### TEST PROCEDURE

Perform the following checks with the NA-5 connected to a Lincoln CV welding power source according to the proper connection diagram. See the **Installation Section** of this manual.

1. Connect the test voltmeter (see Materials Needed) between the "work" and the electrode cable connection at the welding head. See Figure F.7
2. Using the 5/16" nutdriver open the control box PC board access door.
3. Place a jumper wire between leads #2 and #4 located on CR3 relay. See Figure F.8 This this should energize the output terminals of the Lincoln CV welding power source. An open circuit voltage should be present at the welding output terminals. The test voltmeter reading should match the ACTUAL volts meter reading on the NA-5 within +/- 0.5VDC (typically +/- 0.2VDC). If it does not, check the integrity and placement of the voltage sensing leads #21 and #67 and associated wiring. Perform the **Meter Circuit Accuracy Test**.

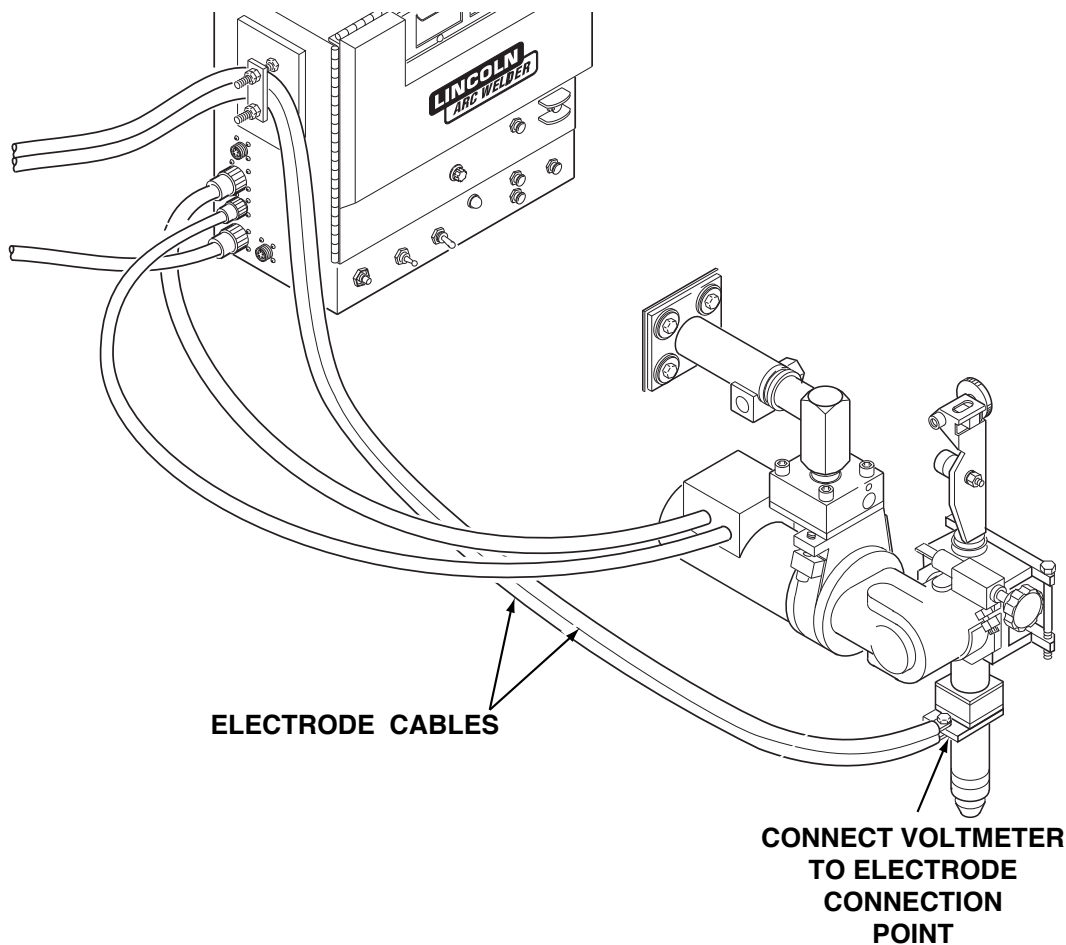
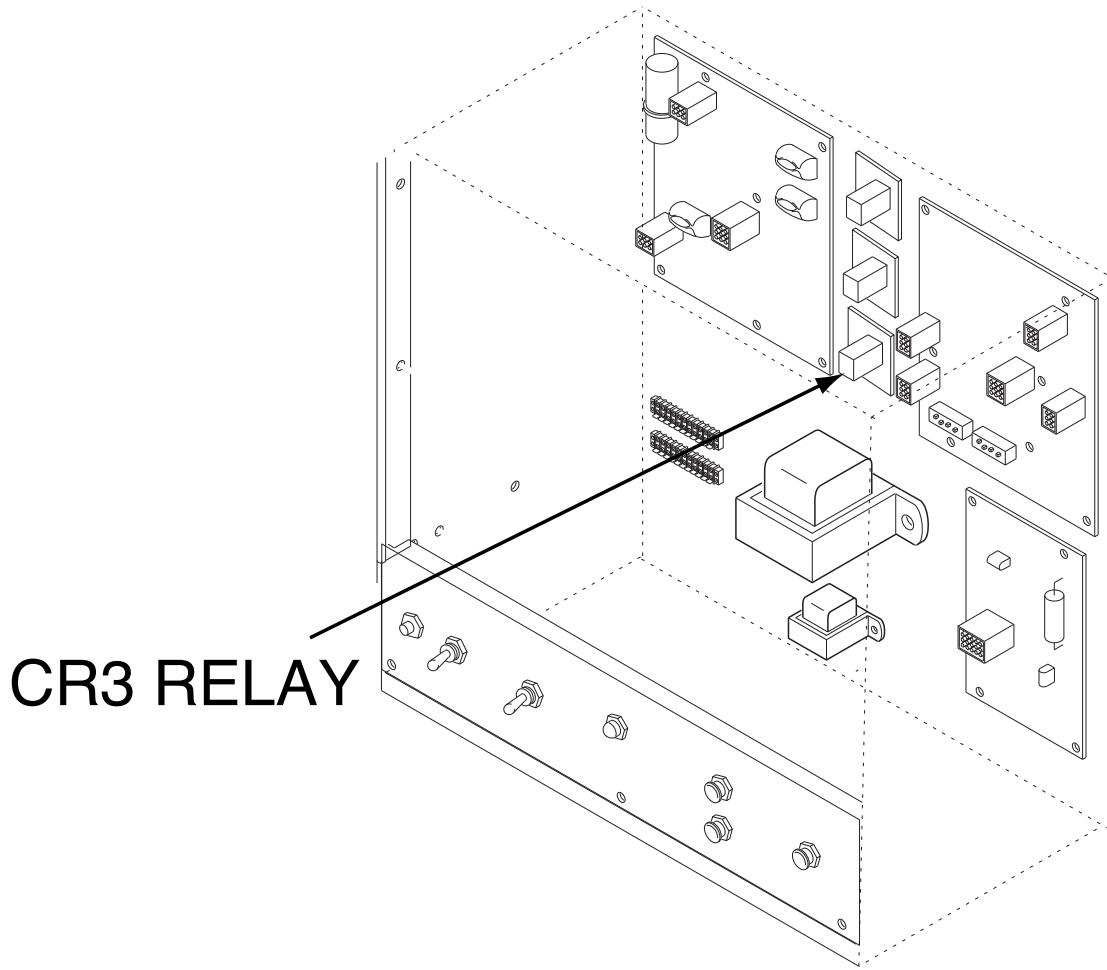

FIGURE F.7 TEST METER CONNECTION POINTS

## VOLTMETER ACCURACY TEST (Continued)



CR3 RELAY

FIGURE F.8 CR3 RELAY

4. Remove the jumper wire from leads #2 and #4.
5. Remove the test voltmeter and, while welding, compare the SET volts and ACTUAL volts meter readings. Depending upon the arc voltage characteristics of the process being welded, the ACTUAL reading may vary somewhat about an average value. The average ACTUAL reading should match the SET reading within +/- 0.5 VDC. If not, refer to the ***Meter Circuit Accuracy Test***.
6. If no further tests are required, remove all test equipment and close and secure the access door.

## WIRE SPEED ACCURACY TEST

### WARNING

Service and repair should be performed only by Lincoln Electric factory trained personnel. Unauthorized repairs performed on this equipment could result in danger to the technician or the machine operator and will invalidate your factory warranty. For your safety and to avoid electrical shock, please observe all safety notes and precautions detailed throughout this manual.

If for any reason you do not understand the test procedures or are unable to perform the tests/repairs safely, contact the Lincoln Electric service department for technical troubleshooting assistance before you proceed.  
Call (216) 383-2531 or 1-888-935-3877.

### TEST DESCRIPTION

This test will help determine if the NA-5 is providing the proper wire feed per inches of revolution of the drive roll.

This procedure takes approximately 20 minutes to perform.

### MATERIALS NEEDED

Ruler or other linear measuring device  
5/16" Nutdriver



## WIRE SPEED ACCURACY TEST (Continued)

### TEST PROCEDURE

Perform the following checks with the NA-5 connected to a Lincoln CV welding power source according to the proper connection diagram. See the **Installation Section** of this manual.

1. Check to make sure the speedmeter calibration jumper is connected to the proper calibration pin for the head and drive roll system being used. See Table F.3

TABLE F.3

SPEEDMETER CALIBRATION	HEAD RATIO	DRIVE ROLL PART NUMBER	WIRE SIZE RANGE	RATED SPEED RANGE (IPM)
21*	21/1	S12778 S19113	Single .035 - .052 Solid Single .045 - .052 Cored	100 - 2070
57F** 57**	57/1 57/1	S12778 S12515	Single .035 - .052 Single 1/16 - 3/32	40 - 778 38 - 762
95	95/1	S12514	Single 3/32 - 5/32	22 - 428
95S***	95/1	S12515 S19113 S13161-052 S13161-5/64 S14904 (Outer) S14905 (Inner)	Single 1/16 - 3/32 Single .045 - .052 Cored Twin .045 - .052 Twin 1/16 - 5/64 Twin 3/32	23 - 456
142	142/1	S12514	Single 3/32 - 7/32	15 - 289
142T***	142/1	S14904 (Outer) S14905 (Inner)	Twin 5/64 - 1/8	15 - 300

\* Present on HI -Speed NA-5 speedmeter board only. \*\* Early speedmeter pins were labeled 55F and 55, respectively.

\*\*\* Early speedmeter PC boards did not include these calibration pins.

## WIRE SPEED ACCURACY TEST (Continued)

2. Check for the proper wire feed inches per revolution of the drive roll.
  - A. Set the Strike speed control to any setting between 50 and 125 IPM. While pressing the INCH DOWN button measure the precise length of wire fed by exactly 10 revolutions of the drive roll. The measured length should be within the range specified in Table F.4 for the drive roll and wire size employed.
  - B. If the measured length is not within the specified lengths there may be a problem with the wire or wire feeding path. See the **Troubleshooting Guide (Feeding Problems)** in this section of the manual. Also check for correct drive roll tension adjustment.

TABLE F.4

DRIVE ROLL PART NUMBER	WIRE SIZE RANGE	INCHES OF WIRE FED PER 10 REVOLUTIONS OF DRIVE ROLL
S12778	Single .035 - .052 Solid	53 - 54
S19113	Single .045 - .052 Cored	53 - 55
S12515	Single 1/16 - 3/32	51 - 53
S12514	Single 3/32 - 5/32	49 - 51
S13161-052	Twin .045 - .052	53 - 55
S13161-5/64	Twin 1/16 - 5/64	53 - 55
S14904 (Outer) S14905 (Inner)	Twin 3/32	51 - 52
S12514	Single 3/32 - 7/32	49 - 52
S14904 (Outer) S14905 (Inner)	Twin 5/64 - 1/8	51 - 53

## WIRE SPEED ACCURACY TEST (Continued)

3. Check for the proper drive roll revolutions per minute. (RPM)
  - A. Adjust the STRIKE speed control to obtain the SET speed specified for the speedmeter calibration pin and head ratio specified per Table F.5 While pressing the INCH down button count the drive roll revolutions in 60 seconds. The drive roll revolutions and actual speed reading should match Table F.5
  - B. If the readings do not match the number in Table F.5 refer to the ***Meter Circuit Accuracy Test.***

TABLE F.5

SPEEDMETER CALIBRATION PIN	HEAD RATIO	SET SPEEDMETER READING (IPM) READING (IPM)	DRIVE ROLL RPM	ACTUAL SPEEDMETER
21*	21/1	0.27 (IPM X 1000)	50 +/- 2	0.27 +/- 0.01 (IPM X 1000)
57F**	57/1	268	50 +/- 1	268 +/- 2
57**	57/1	262	50 +/- 1	262 +/- 2
95	95/1	249	50 +/- 1	249 +/- 2
95S***	95/1	265	50 +/- 1	265 +/- 2
142	142/1	250	50 +/- 1	250 +/- 2
142T***	142/1	260	50 +/- 1	260 +/- 2

\* Present on HI -Speed NA-5 speedmeter board only. \*\* Early speedmeter pins were labeled 55F and 55, respectively.

\*\*\* Early speedmeter PC boards did not include these calibration pins.

**METER CIRCUIT ACCURACY TEST****⚠ WARNING**

Service and repair should be performed only by Lincoln Electric factory trained personnel. Unauthorized repairs performed on this equipment could result in danger to the technician or the machine operator and will invalidate your factory warranty. For your safety and to avoid electrical shock, please observe all safety notes and precautions detailed throughout this manual.

If for any reason you do not understand the test procedures or are unable to perform the tests/repairs safely, contact the Lincoln Electric service department for technical troubleshooting assistance before you proceed.  
Call (216) 383-2531 or 1-888-935-3877.

**TEST DESCRIPTION**

This test will help determine if the NA-5 meter circuit is functioning properly.

The Speed Meter Circuit tests take approximately 15 minutes to perform.

The Volt Meter Circuit tests take approximately 15 minutes to perform.

**MATERIALS NEEDED**

Digital volt/ohmmeter with at least 3-1/2 digits and +/- 0.5% accuracy  
5/16" Nutdriver

## METER CIRCUIT ACCURACY TEST (Continued)

### TEST PROCEDURE

1. Remove input power to the NA-5.
2. Using the 5/16" nutdriver open the control box PC board access door.
3. Locate the voltmeter PC board. See Figure F.9
4. Apply input power to the NA-5.

### 5. Test for AC supply to the voltmeter PC board.

- Check for 8 to 11VAC from lead #601 to #602. See Figure F.9

Note: The coating will have to be removed from the test points to ensure accurate voltmeter readings. If the correct AC voltage is not present check for loose or faulty connects with the associated leads. See wiring diagram.

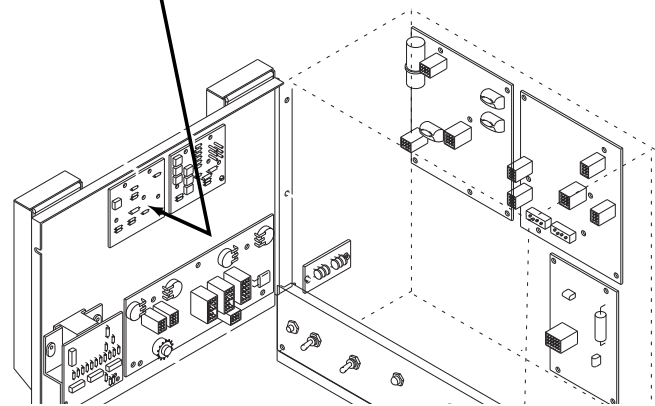
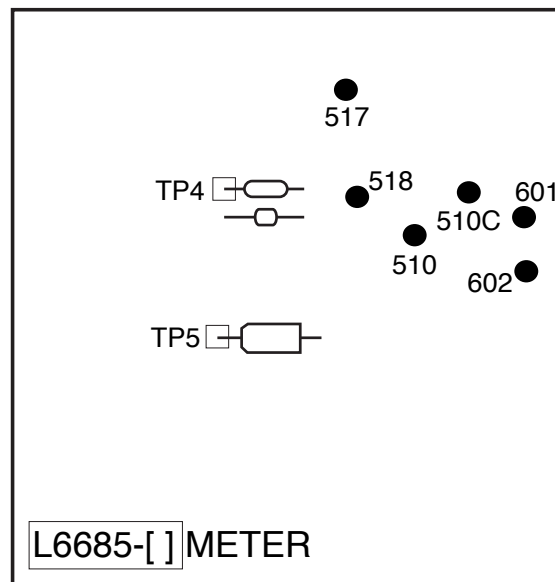

FIGURE F.9 VOLTMETER PC BOARD AND TEST POINTS

## METER CIRCUIT ACCURACY TEST (Continued)

### 6. Test for DC volts on the voltmeter PC board.

- Check for 4.75 to 5.25VDC from TP5 to lead #510C. See **Figure F.9**

Note: The coating will have to be removed from the test points to ensure accurate voltmeter readings.

- If the display is NOT lit and the correct DC voltage is present at TP5 to lead #510C, the digital meter may be faulty. Replace the meter.
- If the AC voltage IS present at leads #601 to #602 and the DC voltage is missing, the voltmeter PC board may be faulty.

### 7. Test Digital Voltmeter Accuracy

- Use a test meter with at least 3-1/2 digits and +/- 0.5% accuracy.
- Connect the + probe to TP4 and the - probe to lead 510C. Do NOT disconnect plug.

Note: The coating will have to be removed from the test points to ensure accurate meter readings.

- With the NA-5 voltmeter reading SET values of STRIKE voltage, adjust the strike voltage control until the test meter matches the settings in the table below.
- If the NA-5 digital voltmeter does not match the readings, the digital meter may be faulty.

NA-5 SET VOLTS READING	TEST VOLTMETER READING
15.0VDC	.150 +/- .004VDC
30.0VDC	.300 +/- .004VDC
60.0VDC	.600 +/- .006 VDC

## METER CIRCUIT ACCURACY TEST (Continued)

### 8. Test Voltmeter PC Board Accuracy

- Use a test meter with at least 3-1/2 digits and +/- 0.5% accuracy.
- Connect the + probe to lead #517 and the - probe to lead #510C. Do not disconnect plug.

Note: The coating will have to be removed from the test points to ensure accurate meter readings.

- With the NA-5 voltmeter reading SET values of STRIKE voltage, adjust the strike voltage control until the NA-5 voltmeter matches the settings in the table below.
- If the test meter does not match the readings, the voltmeter PC board may be faulty.

NA-5 SET VOLTS READING	TEST VOLTMETER READING
15.0VDC	1.50VDC +/- .04
30.0VDC	3.00VDC +/- .04
60.0VDC	6.00VDC +/- .06

## METER CIRCUIT ACCURACY TEST (Continued)

9. Locate the speedmeter PC board.  
See Figure F.10

10. Apply input power to the NA-5.

11. **Test for AC supply to the speedmeter PC board.**

- Check for 8 to 11VAC from lead #601 or #602. See Figure F.10

Note: The coating will have to be removed from the test points to ensure accurate voltmeter readings. If the correct AC voltage is not present check for loose or faulty connects with the associated leads. See wiring diagram.

12. **Test for DC volts on the speedmeter PC board.**

- Check for 4.75 to 5.25VDC from TP5 to lead #510P. See Figure F.10

Note: The coating will have to be removed from the test points to ensure accurate meter readings.

- If the display is NOT lit and the correct DC voltage is present at TP5 to lead #510P, the digital meter may be faulty. Replace the meter.
- If the AC voltage IS present at leads #601 to #602 and the DC voltage is missing, the speedmeter PC board may be faulty.

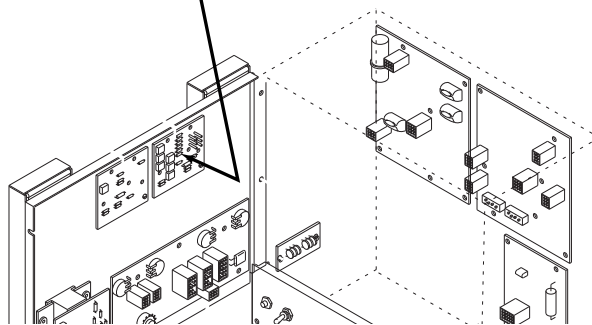
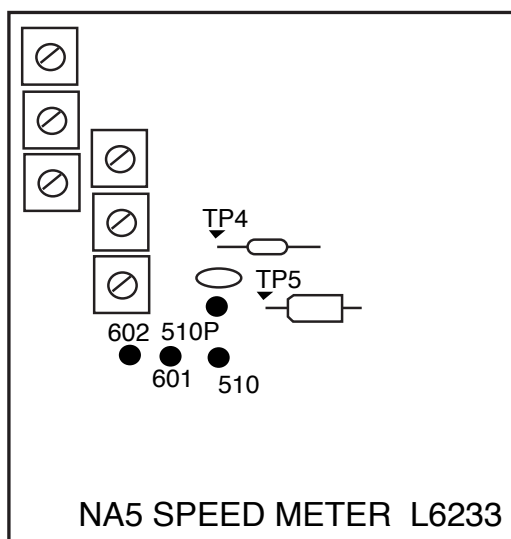

FIGURE F.10 SPEEDMETER PC BOARD AND TEST POINTS



## METER CIRCUIT ACCURACY TEST (Continued)

### 13. Test Speedometer Digital Meter Accuracy

- Use a test meter with at least 3-1/2 digits and +/- 0.5% accuracy.
- Connect the + probe to TP4 and the - probe to lead 510P. Do NOT disconnect plug.

Note: The coating will have to be removed from the test points to ensure accurate meter readings.

- With the NA-5 speedometer reading SET values of STRIKE speed, adjust the strike wire speed control until the test meter matches the settings in the table below.
- If the NA-5 digital speedometer does not match the readings, the digital meter may be faulty.

NA-5 SET SPEED READING (IPM)	TEST VOLTMETER READING
150 (1.50*)	.150 +/- .004VDC
300 (3.00*)	.300 +/- .004VDC

\*For Hi-Speed NA-5 speedometer (IPM X 1000).

## METER CIRCUIT ACCURACY TEST (Continued)

### 14. Test Speedmeter PC Board Accuracy

- Use a test meter with at least 3-1/2 digits and +/- 0.5% accuracy.
- Connect the + probe to lead #519 (Jumper lead) and the - probe to lead #510P. Do not disconnect plug.

Note: The coating will have to be removed from the test points to ensure accurate meter readings.

- With the NA-5 speedmeter reading SET values of STRIKE speed, adjust the strike wire speed control until the NA-5 speedmeter matches the settings in the table below.

- If the test meter does not match the readings, the speedmeter PC board may be faulty.

15. When the testing is complete close and secure the access door.

SPEEDMETER CALIBRATION PIN	NA-5 SET SPEED READING (IPM)	TEST VOLTMETER READING
21*	2.07*	6.00 +/- .06
57F	778	6.00 +/- .06
57	762	6.00 +/- .06
95	428	6.00 +/- .06
95S	456	6.00 +/- .06
142	289	6.00 +/- .06
142T	300	6.00 +/- .06

\* For Hi-Speed NA-5 speedmeter (IPM X 1000)

## PC BOARD(S) REMOVAL AND REPLACEMENT

### WARNING

Service and repair should be performed only by Lincoln Electric factory trained personnel. Unauthorized repairs performed on this equipment could result in danger to the technician or the machine operator and will invalidate your factory warranty. For your safety and to avoid electrical shock, please observe all safety notes and precautions detailed throughout this manual.

If for any reason you do not understand the test procedures or are unable to perform the tests/repairs safely, contact the Lincoln Electric service department for technical troubleshooting assistance before you proceed.  
Call (216) 383-2531 or 1-888-935-3877.

### DESCRIPTION

The following procedure will aid the technician in removing and replacing the printed circuit boards for maintenance or replacement.

This procedure takes approximately 17 minutes to perform.

### MATERIALS NEEDED

Phillips head screwdriver  
5/16" Nutdriver

NA-5



## PC BOARD(S) REMOVAL AND REPLACEMENT (Continued)

### PROCEDURE

Before starting the following procedure, refer to the **PC Board Troubleshooting Procedures** at the beginning of this section.

1. Remove the input power to the NA-5.
2. Using the 5/16" nutdriver open the control box PC board cover.
3. Carefully remove the molex type plugs (and leads) connected to the PC board that is to be removed.
4. Using the phillips head screwdriver, remove the PC board mounting screws.
5. Carefully remove the PC board.

### REPLACEMENT PROCEDURE

1. Using the phillips head screwdriver and mounting screws carefully position and install the new PC board.
2. Reconnect the molex type plugs (and leads) into the new PC board.
3. Close and secure the access door.

**DIGITAL METER AND METER PC BOARD REMOVAL AND REPLACEMENT****⚠ WARNING**

Service and repair should be performed only by Lincoln Electric factory trained personnel. Unauthorized repairs performed on this equipment could result in danger to the technician or the machine operator and will invalidate your factory warranty. For your safety and to avoid electrical shock, please observe all safety notes and precautions detailed throughout this manual.

If for any reason you do not understand the test procedures or are unable to perform the tests/repairs safely, contact the Lincoln Electric service department for technical troubleshooting assistance before you proceed.  
Call (216) 383-2531 or 1-888-935-3877.

**DESCRIPTION**

The following procedure will help the technician remove the digital meters and meter PC boards for repair or replacement.

This meter PC Board portion of this procedure takes approximately 8 minutes to perform.

The total Meter PC Board and Meter Replacement procedure takes approximately 15 minutes to perform.

**MATERIALS NEEDED**

5/16" Nutdriver  
Phillips head screwdriver

## DIGITAL METER AND METER PC BOARD REMOVAL AND REPLACEMENT

### METER PC BOARD REMOVAL PROCEDURE

1. Remove input power to the NA-5.
  2. Using the 5/16" nutdriver open the control box PC board access door.
  3. Locate and unplug the meter PC board that is to be removed. See Figure F.11
  4. Using the 5/16" nutdriver remove the four PC board mounting nuts.
  5. Carefully remove the meter PC board.
- Note insulation placement for reassembly. Also make sure the plug on the back of the PC board plugs into the prongs on the meter when you reassemble.

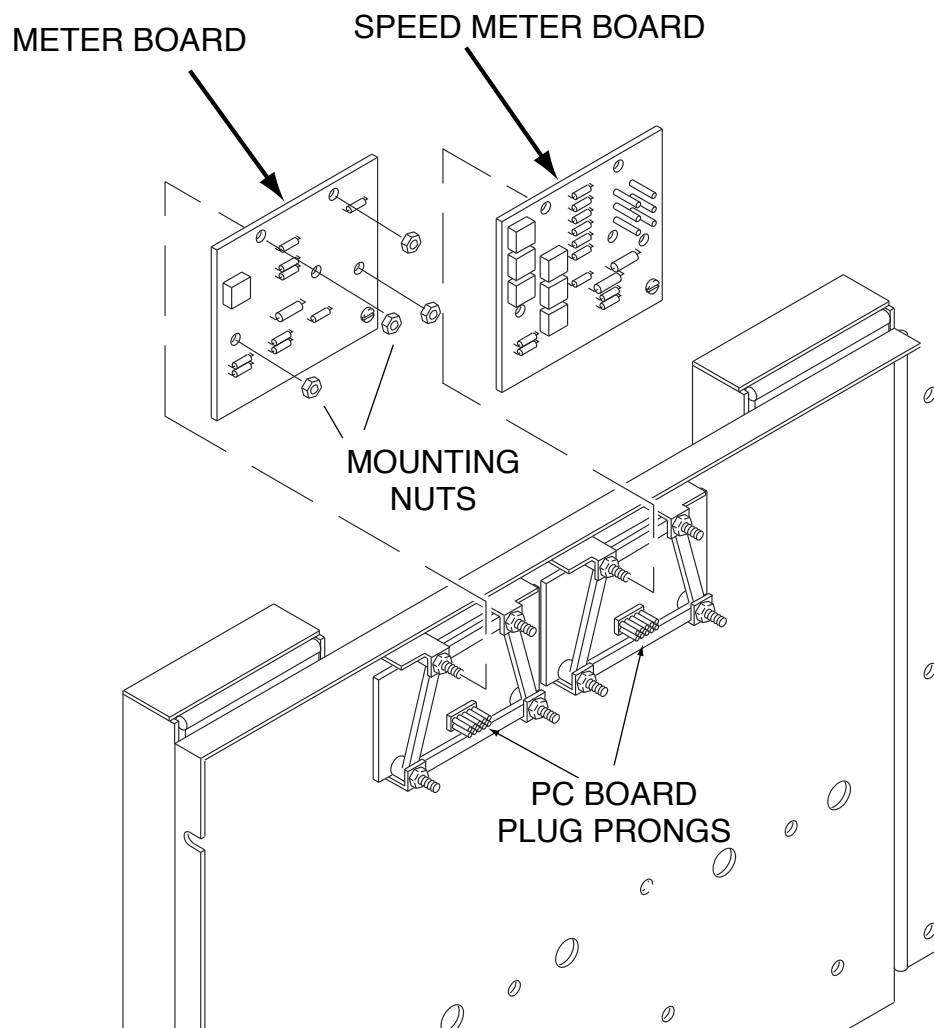

FIGURE F.11 METER PC BOARD, MOUNTING NUTS AND PLUG

## DIGITAL METER AND METER PC BOARD REMOVAL AND REPLACEMENT

### DIGITAL METER REMOVAL PROCEDURE

1. Using the phillips head screwdriver remove the four screws from the meter bezel. See Figure F.12
2. Carefully remove the bezel assembly.
3. Carefully remove the meter shield assembly.
4. Using the 5/16" nutdriver, remove the two nuts, screws and lockwashers holding the digital meter to the cover assembly.
5. Carefully remove the digital meter.

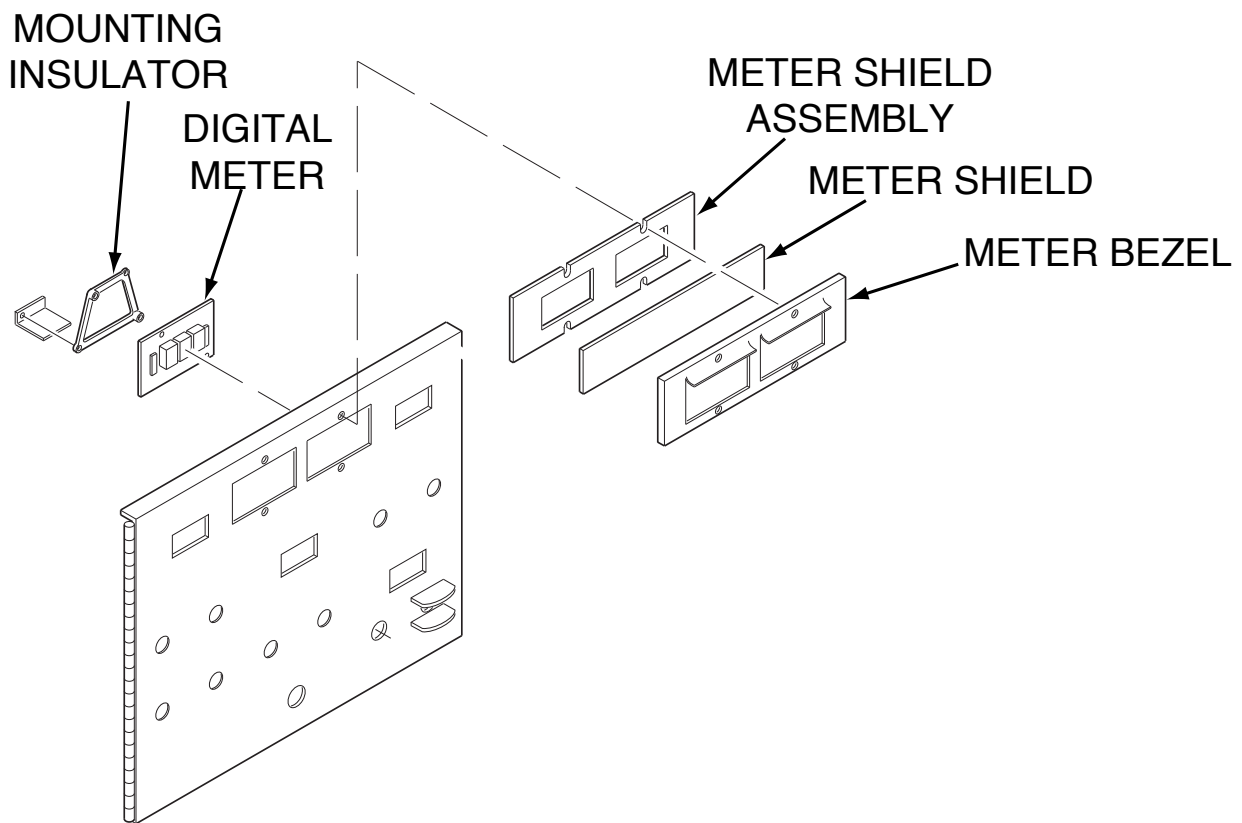

FIGURE F.12 METER BEZEL AND SCREW LOCATIONS

## DIGITAL METER AND METER PC BOARD REMOVAL AND REPLACEMENT

### REPLACEMENT PROCEDURE

1. With the 5/16" nutdriver, fasten the digital meter to the cover assembly with two screws, nuts and lock-washers.
2. Using the phillips head screwdriver, reattach the meter shield and bezel assembly.
3. Position the insulation and plug the PC meter board into the digital meter.
4. Mount the meter PC board using the four nuts previously removed.
5. Reattach the molex plug.
6. Close and secure the access door.

Return to Section TOC

Return to Master TOC

Return to Section TOC

Return to Master TOC

Return to Section TOC

Return to Master TOC

Return to Section TOC

Return to Master TOC



## TACH PC BOARD REMOVAL AND REPLACEMENT

### WARNING

Service and repair should be performed only by Lincoln Electric factory trained personnel. Unauthorized repairs performed on this equipment could result in danger to the technician or the machine operator and will invalidate your factory warranty. For your safety and to avoid electrical shock, please observe all safety notes and precautions detailed throughout this manual.

If for any reason you do not understand the test procedures or are unable to perform the tests/repairs safely, contact the Lincoln Electric service department for technical troubleshooting assistance before you proceed.  
Call (216) 383-2531 or 1-888-935-3877.

### DESCRIPTION

The following procedure will help the technician remove the Tach PC board and related components for repair or replacement.

This procedure takes approximately 9 minutes to perform.

### MATERIALS NEEDED

5/16" Nutdriver  
Slot head screwdriver  
Phillips head screwdriver  
3/8" Wrench

NA-5

 LINCOLN  
ELECTRIC

## TACH PC BOARD REMOVAL AND REPLACEMENT (Continued)

### PROCEDURE

1. Remove input power to the NA-5.
2. With the 5/16" nutdriver locate and remove the four screws holding the tach cover to the wire feed drive motor. See Figure F.13
3. Using the 5/16" nutdriver remove the two screws from the connection box cover.
4. Locate and disconnect the in-line connectors from leads #510A, #525A and #555.
5. Using the phillips head screwdriver, remove the two screws from the pick-up assembly cover . See **Figure F.14**. Remove the cover.
6. Hold the nut in place with the 3/8" wrench. With the phillips head screwdriver, remove the locking screw from the rotating disc. See **Figure F.15**

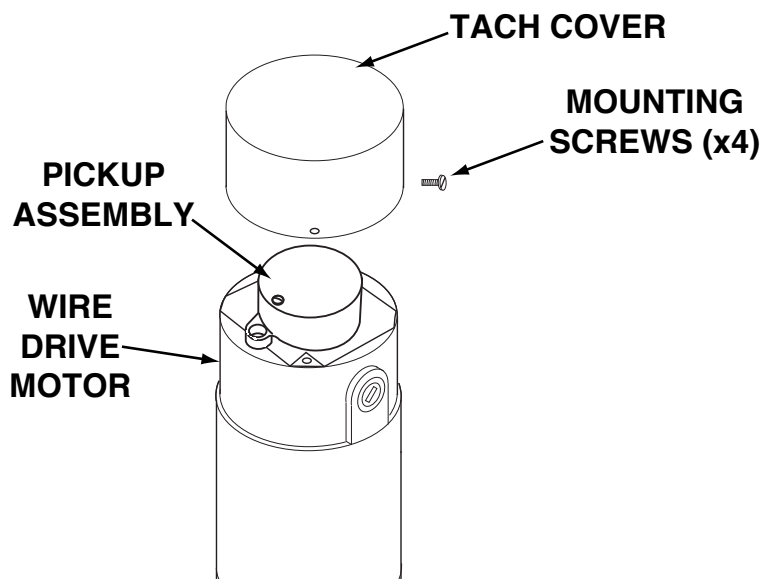

FIGURE F.13 DRIVE MOTOR, TACH COVER, AND CONNECTION BOX

## TACH PC BOARD REMOVAL AND REPLACEMENT (Continued)

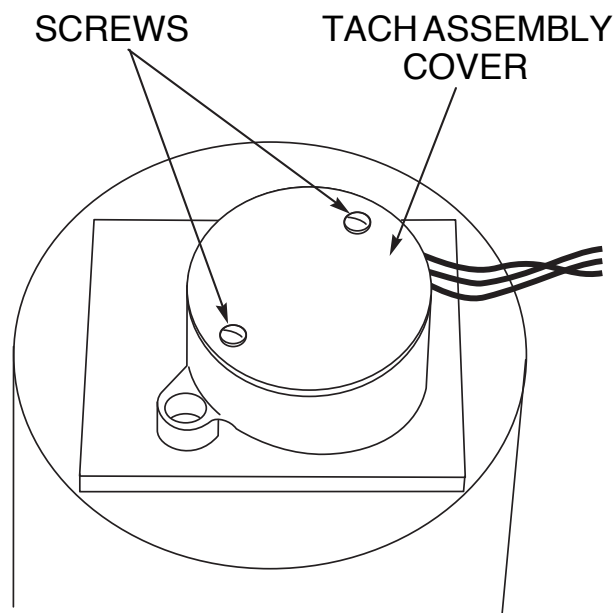

FIGURE F.14 PICK-UP ASSEMBLY AND COVER

7. Carefully remove the rotating disc and tach PC board together. Note spacer washers underneath the disc.
8. If tach PC board is to be removed carefully remove leads from connection box and cover plate.

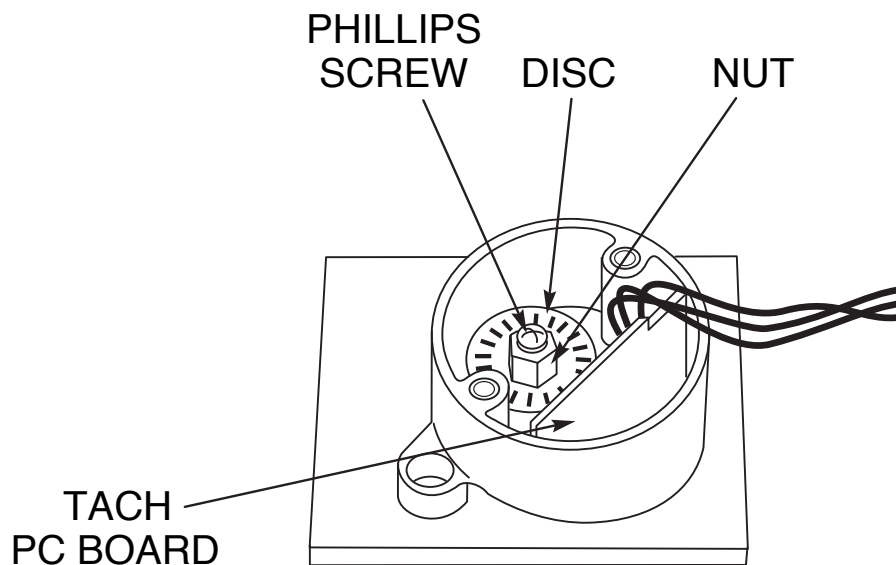

FIGURE F.15 ROTATING DISC, NUT AND TACH BOARD

**TACH PC BOARD REMOVAL AND REPLACEMENT** (Continued)**REASSEMBLY**

1. Upon reassembly the spacers must be used to assure that the disc rotates freely and smoothly within the sensor "window" on the printed circuit board. Note the tach PC board must be held in place when aligning the rotating disc in the sensor window. Press down on the tach PC board with your finger to simulate the cover.
2. Use the 3/8" wrench to hold the nut in place. Attach the rotating disc with the phillips head screw.
3. Thread leads #510A, #525A and #555 through the cover plate and into the connection box. Attach to their respective in-line connectors.
4. Replace the connection box cover.
5. Replace the pick-up assembly cover.
6. Reattach the tach cover to the wire feed drive motor.

Return to Section TOC

Return to Section TOC

Return to Section TOC

Return to Section TOC

Return to Master TOC

Return to Master TOC

Return to Master TOC

Return to Master TOC

NA-5

**LINCOLN**  
ELECTRIC

## WIRE DRIVE MOTOR REMOVAL AND REPLACEMENT

### WARNING

Service and repair should be performed only by Lincoln Electric factory trained personnel. Unauthorized repairs performed on this equipment could result in danger to the technician or the machine operator and will invalidate your factory warranty. For your safety and to avoid electrical shock, please observe all safety notes and precautions detailed throughout this manual.

If for any reason you do not understand the test procedures or are unable to perform the tests/repairs safely, contact the Lincoln Electric service department for technical troubleshooting assistance before you proceed.  
Call (216) 383-2531 or 1-888-935-3877.

### DESCRIPTION

This procedure will aid the technician in the removal and replacement of the drive motor to the gear box and also associated wiring to the control box.

This procedure takes approximately 35 minutes to perform.

### MATERIALS NEEDED

7/16" Wrench  
5/16" Nutdriver  
Large slot head screwdriver

## WIRE DRIVE MOTOR REMOVAL AND REPLACEMENT (Continued)

### MOTOR REMOVAL PROCEDURE

1. Remove input power to the NA-5.
2. Remove the motor and tach cable from the NA-5 control box.
3. Perform the ***Tach Board Removal Procedure***.
4. Using the slot head screwdriver remove the two screws mounting the tach housing to the drive motor. Remove the tach housing from the drive motor.
5. Using the phillips head screwdriver remove the cover plate adaptor. See Figure F.16
6. Using the 5/16" nutdriver remove the clamp holding the connection box to the drive motor.
7. Carefully remove the connection box being careful not to stretch the leads.

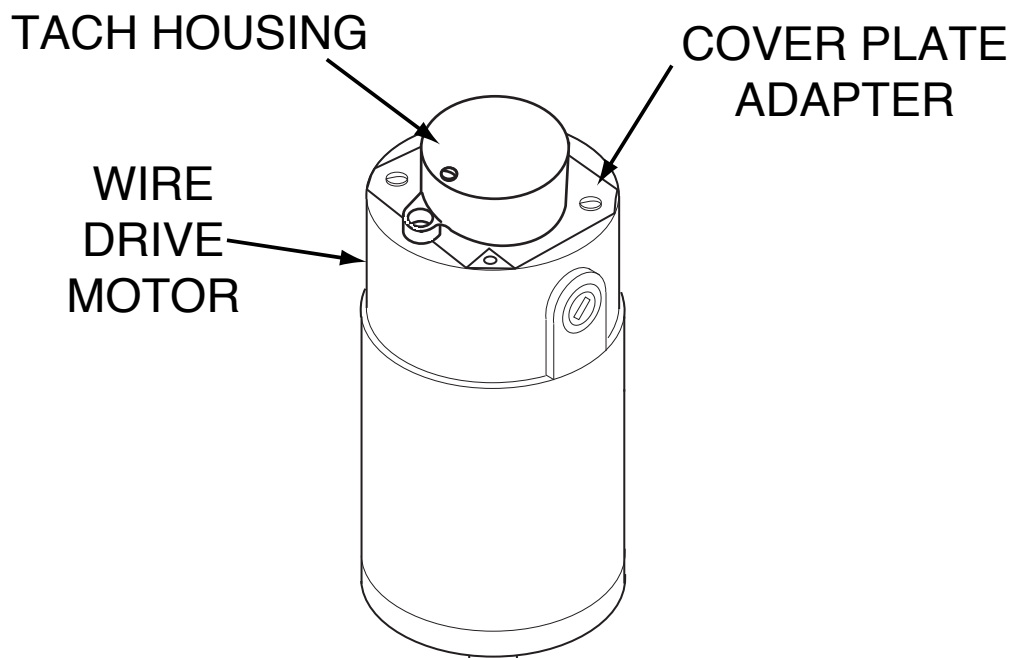

FIGURE F.16 DRIVE MOTOR AND TACH HOUSING

## WIRE DRIVE MOTOR REMOVAL AND REPLACEMENT (Continued)

8. Remove leads #67, #627, #626, #539 and #541 from the terminal strip in the connector box.
9. Using the 7/16" wrench, remove two 1/4-20 bolts holding the adapter plate and motor assembly to the wire feed gear box. (Older models may have slot head 1/4-20 bolts). See Figure F.17
10. Using the large slot head screwdriver, remove the two slot head screws that go through the wire feed gear box and into the adapter plate.
11. Carefully remove the adapter plate and motor assembly (with pinion attached).
12. With a slot head screwdriver, remove the adapter plate from the drive motor.

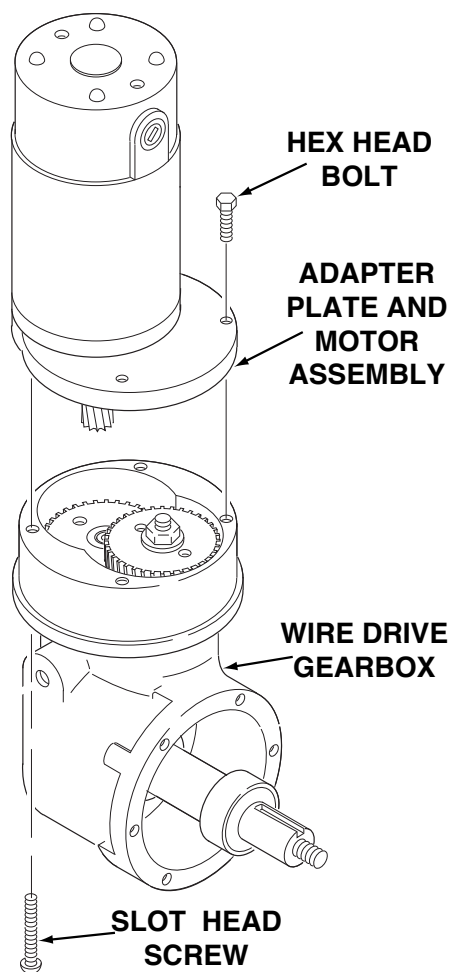

FIGURE F.17 DRIVE MOTOR

## WIRE DRIVE MOTOR REMOVAL AND REPLACEMENT (Continued)

### MOTOR REPLACEMENT PROCEDURE

1. Attach the adapter plate to the drive motor using the slot head screwdriver.
2. Carefully install the replacement motor (with correct pinion) and mount the adapter mounting plate using the 1/4-20 bolts and slot head screws previously removed.
3. Attach leads #67, #627, #626, #539 and #541 to their respective terminals in the connector box.
4. Carefully position the connector box and clamp to the drive motor and using the 5/16" nutdriver secure in position. Be sure NOT to "pinch" any leads.
5. Using the phillips head screwdriver mount the cover plate adaptor to the drive motor.
6. Using the slot head screwdriver attach the tach housing to the drive motor.
7. Perform the ***Tach Board Replacement Procedure***.
8. Assemble the motor and tach cables to the NA-5 control box.

Return to Section TOC

Return to Section TOC

Return to Section TOC

Return to Section TOC

Return to Master TOC

Return to Master TOC

Return to Master TOC

Return to Master TOC



**RETEST AFTER REPAIR**

If a failed test indicates that any mechanical part that could affect the machine's electrical characteristics must be replaced or if any electrical components are repaired or replaced, the machine must be retested and must meet the following standards.

Wire Feed Speed per following table:.....

<b>Gear Ratio</b>	<b>Wire Speed Range in/min (m/min)</b>
21/1	100-2070 (2.54-52.58)
57/1	38-778 (.97-19.76)
95/1	22-456 (.56-11.58)
142/1	15-300 (.38-7.62)

LEDS .....Must operate per PC Board LED Definitions table in ***Troubleshooting Section.***

Flux or Water Solenoid .....Must operate when "Start" switch is pressed.

Relay 3CR .....Must operate and "close" power source contactor.

Relay 2CR .....Must operate and activate external travel circuit, if used.

Voltmeter .....Refer to ***Voltmeter Accuracy Test.***

Wire Speed Meter .....Refer to ***Wire Speed Accuracy Test.***

Voltage control and shutdown .....Refer to ***Out of Voltage Range Shut Down Test.***

Return to Section TOC  
Return to Master TOC  
Return to Section TOC  
Return to Master TOC  
Return to Section TOC  
Return to Master TOC  
Return to Section TOC  
Return to Master TOC

Return to Section TOC

Return to Section TOC

Return to Section TOC

Return to Section TOC

Return to Master TOC

Return to Master TOC

Return to Master TOC

TABLE OF CONTENTS  
-ELECTRICAL DIAGRAMS SECTION-

<b>Electrical Diagrams .....</b>	<b>Section G</b>
Wiring Diagram .....	G-2
Logic PC Board (L6242-1) Schematic .....	G-3
Logic PC Board (L6242-2 & above) Schematic .....	G-4
Power PC Board (L6252-1) Schematic .....	G-5
Power PC Board (L6252-2 & above) Schematic .....	G-6
Voltage PC Board Schematic .....	G-7
Control Circuit Schematic .....	G-8
Procedure Board Schematic .....	G-9
Option & Timer Board Schematics .....	G-10
Meter PC Board Schematic & Layout .....	G-11
Miscellaneous PC Board Layouts .....	G-12

Return to Master TOC

Return to Master TOC

Return to Master TOC

Return to Master TOC

# NOTES

---

Return to Section TOC

Return to Section TOC

Return to Section TOC

Return to Section TOC

Return to Master TOC

Return to Master TOC

Return to Master TOC

Wiring Diagram

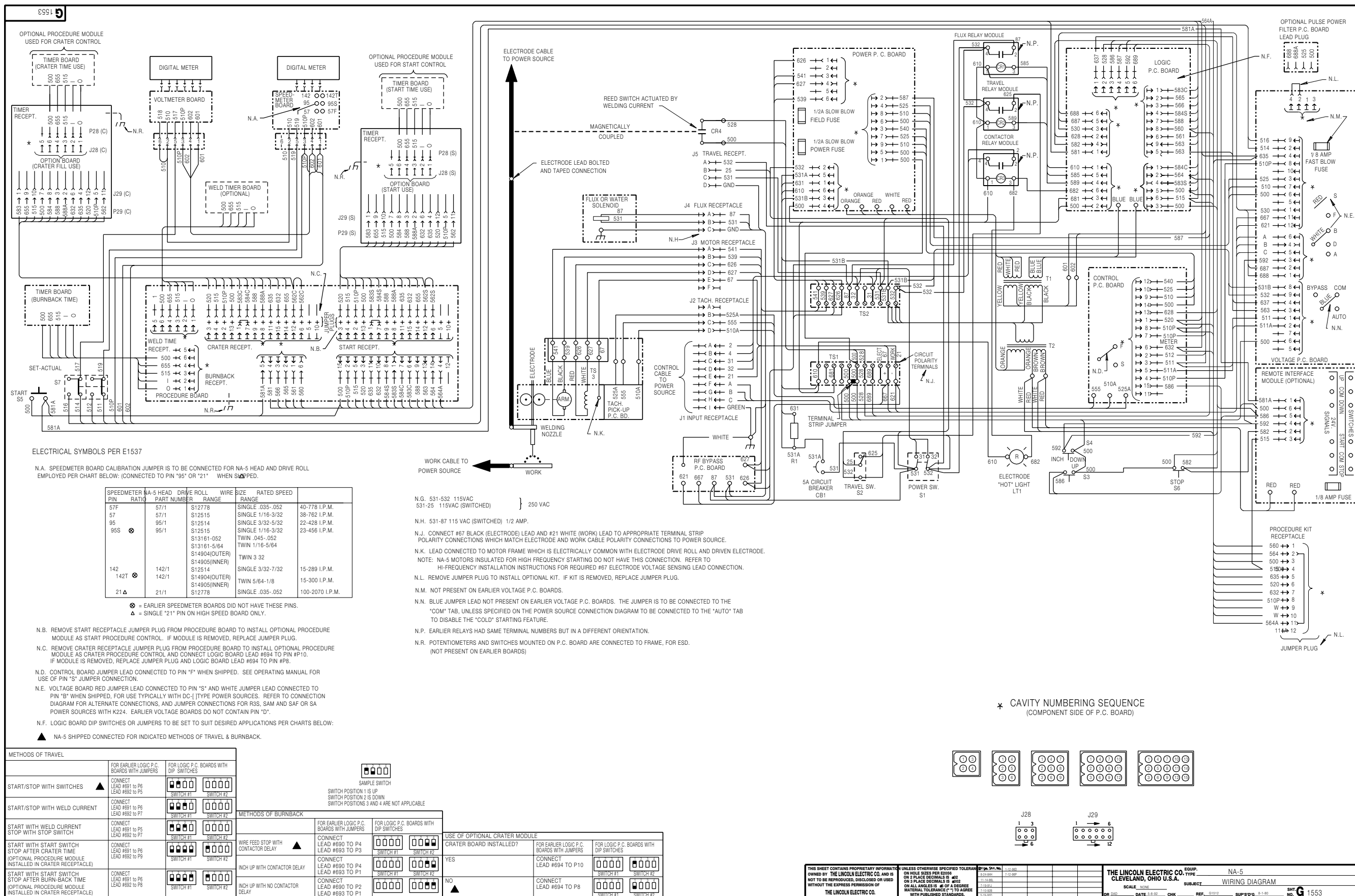

NOTE: This diagram is for reference only. It may not be accurate for all machines covered by this manual.

LOGIC PC BOARD (L6242-1) SCHEMATIC

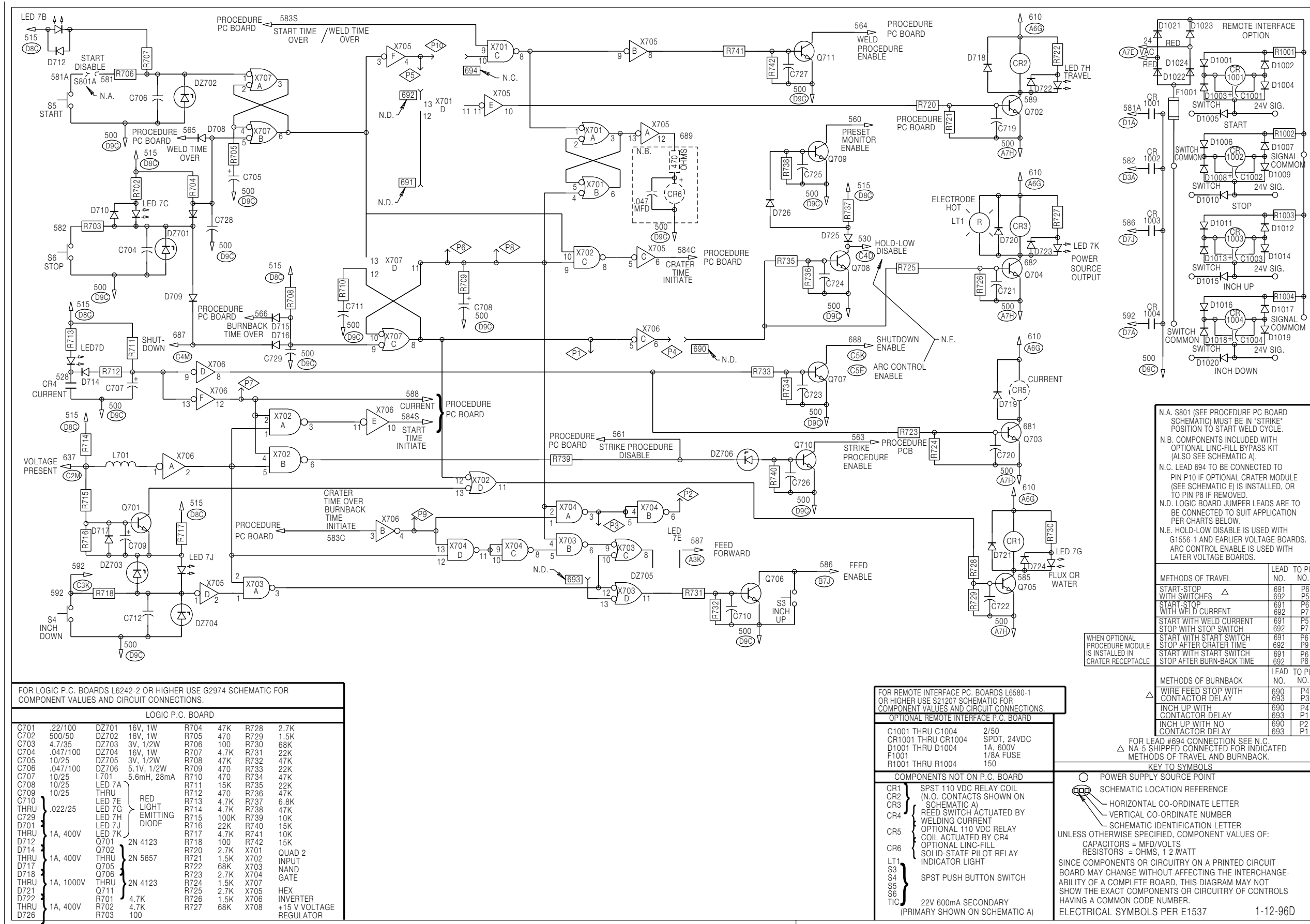

N.A. S801 (SEE PROCEDURE PC BOARD SCHEMATIC) MUST BE IN "STRIKE" POSITION TO START WELD CYCLE.  
 N.B. COMPONENTS INCLUDED WITH OPTIONAL LINC-FILL BYPASS KIT (ALSO SEE SCHEMATIC A).  
 N.C. LEAD 694 TO BE CONNECTED TO PIN P10 IF OPTIONAL CRATER MODULE (SEE SCHEMATIC E) IS INSTALLED, OR TO PIN P8 IF REMOVED.  
 N.D. LOGIC BOARD JUMPER LEADS ARE TO BE CONNECTED TO SUIT APPLICATION PER CHARTS BELOW.  
 N.E. HOLD-LOW DISABLE IS USED WITH G1556-1 AND EARLIER VOLTAGE BOARDS. ARC CONTROL ENABLE IS USED WITH LATER VOLTAGE BOARDS.

METHODS OF TRAVEL	LEAD NO.	TO PIN NO.
START-STOP WITH SWITCHES	691	P6
START-STOP WITH WELD CURRENT	691	P6
START WITH WELD CURRENT STOP WITH STOP SWITCH	691	P5
START WITH START SWITCH STOP AFTER CRATER TIME	691	P6
START WITH START SWITCH STOP AFTER BURN-BACK TIME	691	P8

METHODS OF BURNBACK	LEAD NO.	TO PIN NO.
WIRE FEED STOP WITH CONTACTOR DELAY	690	P4
INCH UP WITH CONTACTOR DELAY	690	P4
INCH UP WITH NO CONTACTOR DELAY	690	P2

FOR LEAD #694 CONNECTION SEE N.C.  
 Δ NA-5 SHIPPED CONNECTED FOR INDICATED METHODS OF TRAVEL AND BURNBACK.

KEY TO SYMBOLS

○ POWER SUPPLY SOURCE POINT  
 □ SCHEMATIC LOCATION REFERENCE  
 — HORIZONTAL CO-ORDINATE LETTER  
 — VERTICAL CO-ORDINATE NUMBER  
 — SCHEMATIC IDENTIFICATION LETTER

UNLESS OTHERWISE SPECIFIED, COMPONENT VALUES OF:  
 CAPACITORS = MFD/VOLTS  
 RESISTORS = OHMS, 1/2 WATT

SINCE COMPONENTS OR CIRCUITRY ON A PRINTED CIRCUIT BOARD MAY CHANGE WITHOUT AFFECTING THE INTERCHANGEABILITY OF A COMPLETE BOARD, THIS DIAGRAM MAY NOT SHOW THE EXACT COMPONENTS OR CIRCUITRY OF CONTROLS HAVING A COMMON CODE NUMBER.

ELECTRICAL SYMBOLS PER E1537 1-12-96D

FOR LOGIC P.C. BOARDS L6242-2 OR HIGHER USE G2974 SCHEMATIC FOR COMPONENT VALUES AND CIRCUIT CONNECTIONS.

LOGIC P.C. BOARD					
C701	.22/100	DZ701	16V, 1W	R704	47K
C702	500/50	DZ702	16V, 1W	R705	470
C703	4.7/35	DZ703	3V, 1/2W	R706	100
C704	.047/100	DZ704	16V, 1W	R707	4.7K
C705	10/25	DZ705	3V, 1/2W	R708	47K
C706	.047/100	DZ706	5.1V, 1/2W	R709	470
C707	10/25	L701	5.6mH, 28mA	R710	470
C708	10/25	LED 7A		R711	15K
C709	10/25	THRU		R712	470
C710	022/25	LED 7E		R713	4.7K
THRU		LED 7G		R714	4.7K
C729		LED 7H		R715	100K
D701		LED 7J		R716	22K
THRU	1A, 400V	LED 7K		R717	4.7K
D712		Q701	2N 4123	R718	100
D714		Q702		R720	2.7K
THRU	1A, 400V	THRU	2N 5657	R721	1.5K
D717		Q705		R722	68K
D718		Q706		R723	2.7K
THRU	1A, 1000V	THRU	2N 4123	R724	1.5K
D721		Q711		R725	2.7K
D722		R701	4.7K	R726	1.5K
THRU	1A, 400V	R702	4.7K	R727	68K
D726		R703	100	X701	QUAD 2
				X702	INPUT
				X703	NAND
				X704	GATE
				X705	HEX
				X706	INVERTER
				X707	+15 V VOLTAGE
				X708	REGULATOR

FOR REMOTE INTERFACE P.C. BOARDS L6580-1 OR HIGHER USE S21207 SCHEMATIC FOR COMPONENT VALUES AND CIRCUIT CONNECTIONS.

OPTIONAL REMOTE INTERFACE P.C. BOARD	
C1001 THRU C1004	2/50
CR1001 THRU CR1004	SPDT, 24VDC
D1001 THRU D1004	1A, 600V
F1001	1/8A FUSE
R1001 THRU R1004	150

COMPONENTS NOT ON P.C. BOARD	
CR1	SPST 110 VDC RELAY COIL (N.O. CONTACTS SHOWN ON SCHEMATIC A)
CR2	REED SWITCH ACTUATED BY WELDING CURRENT
CR3	OPTIONAL 110 VDC RELAY COIL ACTUATED BY CR4
CR4	SOLID-STATE PILOT RELAY INDICATOR LIGHT
CR5	
CR6	
LT1	
S3	
S4	
S5	
S6	
TIC	22V 600mA SECONDARY (PRIMARY SHOWN ON SCHEMATIC A)



NOTE: Lincoln Electric assumes no responsibility for liabilities resulting from board level troubleshooting. PC Board repairs will invalidate your factory warranty. Individual Printed Circuit Board Components are not available from Lincoln Electric. This information is provided for reference only. Lincoln Electric discourages board level troubleshooting and repair since it may compromise the quality of the design and may result in danger to the Machine Operator or Technician. Improper PC board repairs could result in damage to the machine.

LOGIC PC BOARD (L6242-2 & above) SCHEMATIC

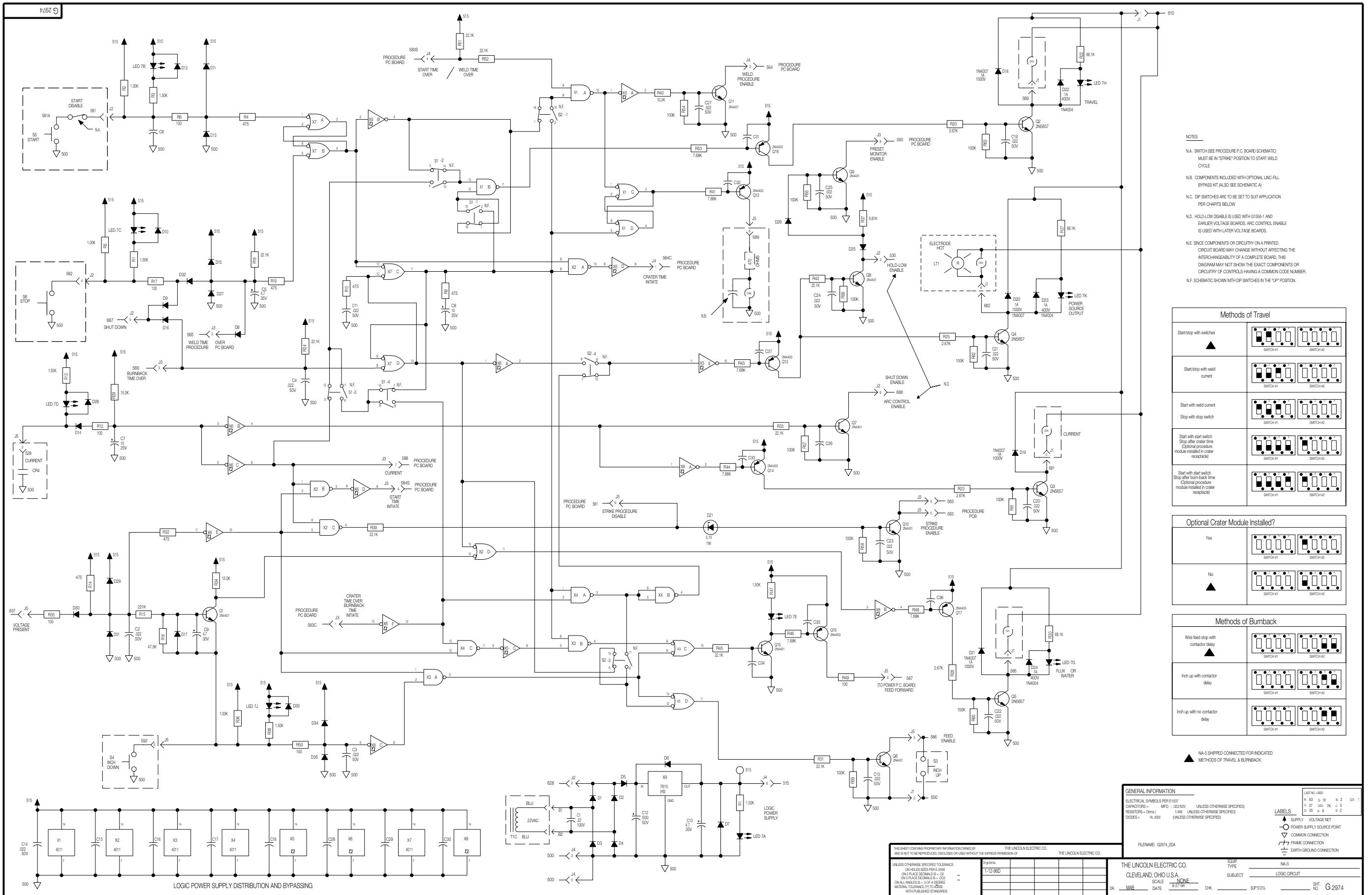

**NOTES:**

- N.A. SWITCH (SEE PROCEDURE P.C. BOARD SCHEMATIC) MUST BE IN "STRIKE" POSITION TO START WELD CYCLE
- N.B. COMPONENTS INCLUDED WITH OPTIONAL LINC-FILL BYPASS KIT (ALSO SEE SCHEMATIC A)
- N.C. DIP SWITCHES ARE TO BE SET TO SUIT APPLICATION PER CHARTS BELOW
- N.D. HOLD-LOW DISABLE IS USED WITH G1555-1 AND EARLIER VOLTAGE BOARDS. ARC CONTROL ENABLE IS USED WITH LATER VOLTAGE BOARDS.
- N.E. SINCE COMPONENTS OR CIRCUITRY ON A PRINTED CIRCUIT BOARD MAY CHANGE WITHOUT AFFECTING THE INTERCHANGEABILITY OF A COMPLETE BOARD, THIS DIAGRAM MAY NOT SHOW THE EXACT COMPONENTS OR CIRCUITRY OF CONTROLS HAVING A COMMON CODE NUMBER.
- N.F. SCHEMATIC SHOWN WITH DIP SWITCHES IN THE "UP" POSITION.

**Methods of Travel**

Start/stop with switches	
Start/stop with weld current	
Start with weld current Stop with stop switch	
Start with start switch Stop after crater time Optional procedure module installed in crater receptacle	
Start with start switch Stop after burnback time Optional procedure module installed in crater receptacle	

**Optional Crater Module Installed?**

Yes	
No	

**Methods of Burnback**

Wire feed stop with contactor delay	
Inch up with contactor delay	
Inch up with no contactor delay	

▲ N.A. SHIPPED CONNECTED FOR INDICATED METHODS OF TRAVEL & BURNBACK.

**GENERAL INFORMATION**

ELECTRICAL SYMBOLS PER IEC607 CAPACITORS - MFD 1/200V UNLESS OTHERWISE SPECIFIED RESISTORS - Ohms 1/4W UNLESS OTHERWISE SPECIFIED DIODES - 1A, 40V UNLESS OTHERWISE SPECIFIED

FILENAME: G2974\_2DA

THE LINCOLN ELECTRIC CO. CLEVELAND, OHIO U.S.A. SCALE: NONE

DR: MAR DATE: 9/27/94 CHK: SPS/DLS SH: NO. G2974

THIS SHEET CONTAINS PROPRIETARY INFORMATION OWNED BY THE LINCOLN ELECTRIC CO. AND IS NOT TO BE REPRODUCED, DISCLOSED OR USED WITHOUT THE EXPRESS PERMISSION OF THE LINCOLN ELECTRIC CO.

UNLESS OTHERWISE SPECIFIED TOLERANCE:	ON HOLES: SEE PERI-E-0066
	ON PLACES: DECIMALS 0.1 & 0.01
	ON ALL ANGLES: 0.1 - 30° IF ASSUMED
	MATERIAL TOLERANCE: 1% TO 4% WITH PUBLISHED DIMENSIONS

Return to Section TOC

**NOTE:** Lincoln Electric assumes no responsibility for liabilities resulting from board level troubleshooting. PC Board repairs will invalidate your factory warranty. **Individual Printed Circuit Board Components are not available from Lincoln Electric.** This information is provided for reference only. Lincoln Electric discourages board level troubleshooting and repair since it may compromise the quality of the design and may result in danger to the Machine Operator or Technician. Improper PC board repairs could result in damage to the machine.



POWER PC BOARD (L6252-1) SCHEMATIC

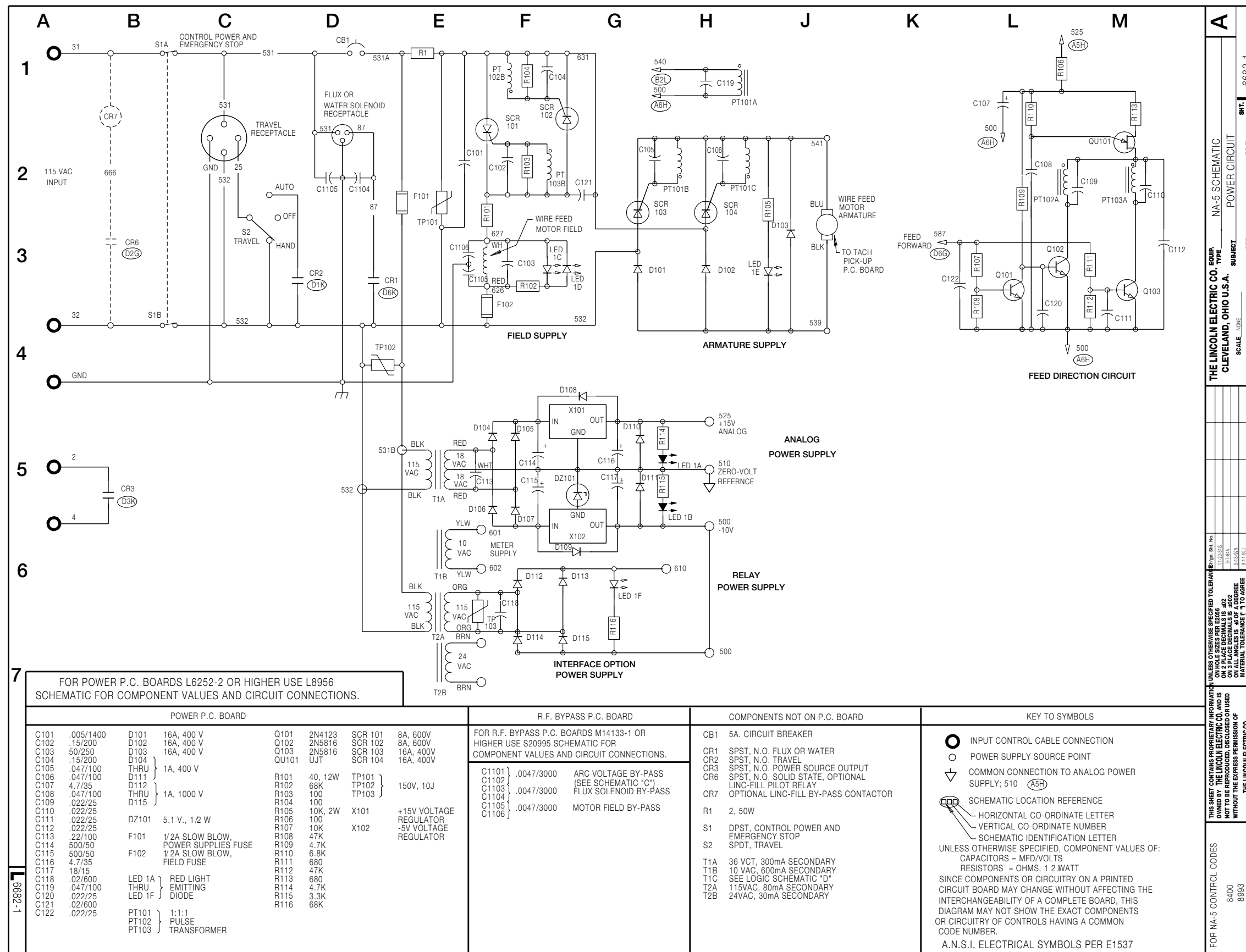

THE LINCOLN ELECTRIC CO. EQUIP. NA-5 SCHEMATIC  
 CLEVELAND, OHIO U.S.A. POWER CIRCUIT  
 SCALE: NONE SUBJECT: SUPERDQ 10.9.81  
 DATE: 12.91 CHK: REF. SMT. NO. 6682-1

Return to Section TOC  
 Return to Master TOC  
 Return to Section TOC  
 Return to Master TOC  
 Return to Section TOC  
 Return to Master TOC  
 Return to Section TOC  
 Return to Master TOC

**NOTE:** Lincoln Electric assumes no responsibility for liabilities resulting from board level troubleshooting. PC Board repairs will invalidate your factory warranty. **Individual Printed Circuit Board Components are not available from Lincoln Electric.** This information is provided for reference only. Lincoln Electric discourages board level troubleshooting and repair since it may compromise the quality of the design and may result in danger to the Machine Operator or Technician. Improper PC board repairs could result in damage to the machine.





POWER PC BOARD (L6252-2 & above) SCHEMATIC

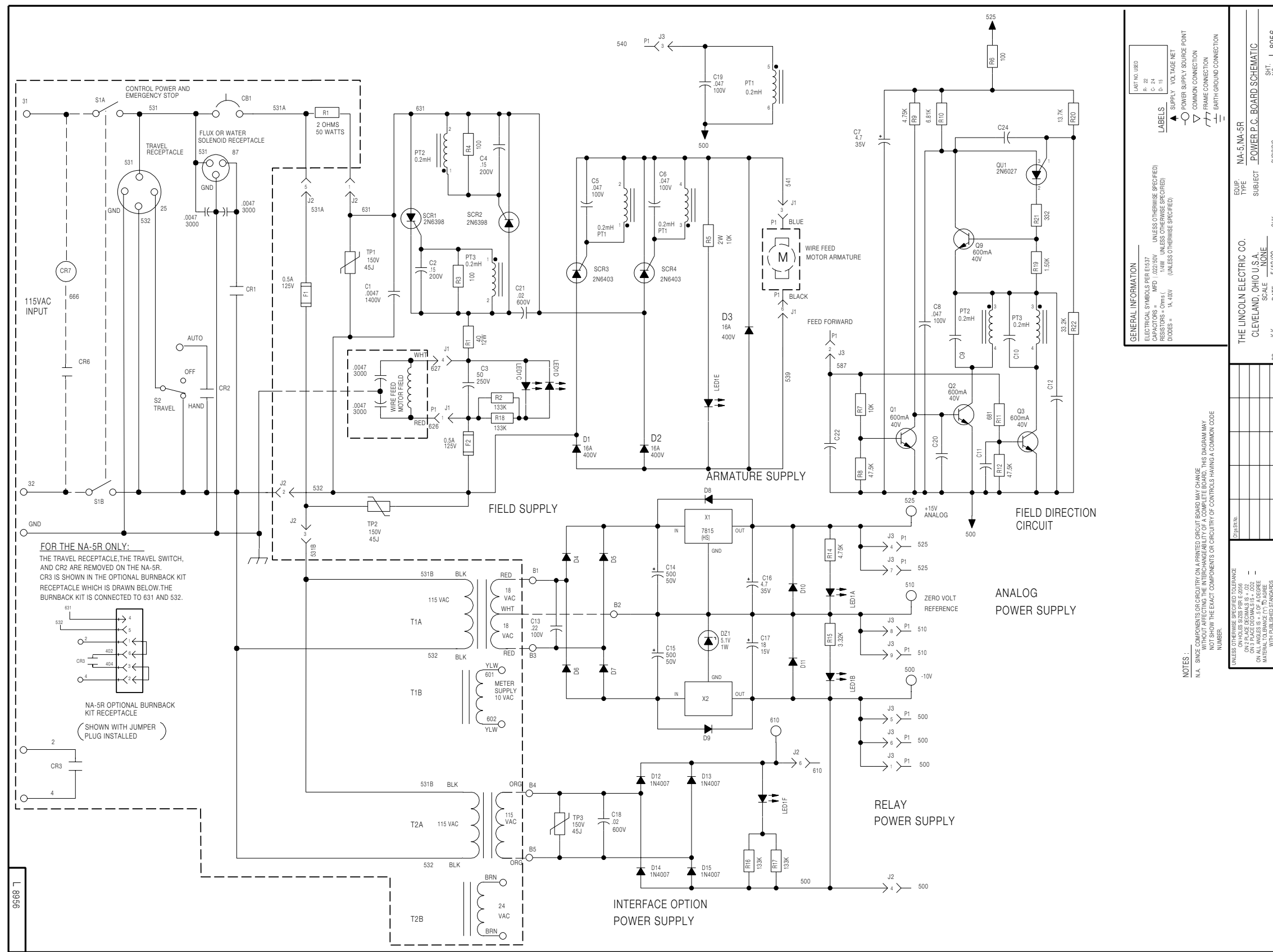

**NOTE:** Lincoln Electric assumes no responsibility for liabilities resulting from board level troubleshooting. PC Board repairs will invalidate your factory warranty. **Individual Printed Circuit Board Components are not available from Lincoln Electric.** This information is provided for reference only. Lincoln Electric discourages board level troubleshooting and repair since it may compromise the quality of the design and may result in danger to the Machine Operator or Technician. Improper PC board repairs could result in damage to the machine.



Return to Section TOC  
 Return to Master TOC  
 Return to Section TOC  
 Return to Master TOC  
 Return to Section TOC  
 Return to Master TOC  
 Return to Section TOC  
 Return to Master TOC

VOLTAGE PC BOARD SCHEMATIC

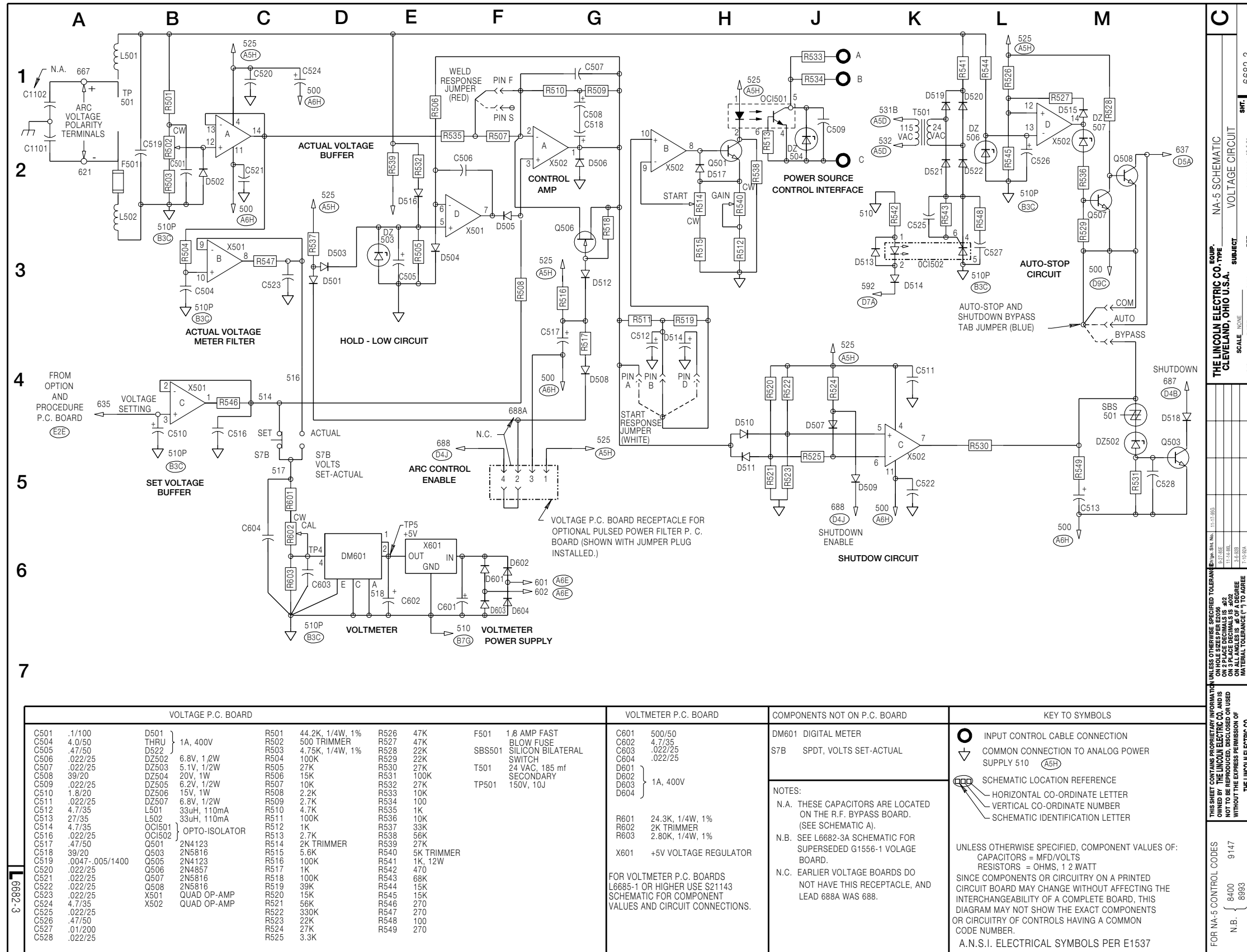

THE LINCOLN ELECTRIC CO., TYPE NA-5 SCHEMATIC VOLTAGE CIRCUIT  
 CLEVELAND, OHIO U.S.A. SUBJECT  
 SCALE NONE REF. 6682-3  
 DATE 2-2-82 CHK. sup:pdq 10-12-81 SHF. L 6682-3

UNLESS OTHERWISE SPECIFIED, TOLERANCES ARE:  
 DIMENSIONS - AS SHOWN  
 ANGLES - AS SHOWN  
 HOLE LOCATIONS - AS SHOWN  
 MATERIAL TOLERANCE - AS SHOWN  
 WITH PUBLISHED STANDARDS.

THIS SHEET CONTAINS PROPRIETARY INFORMATION OWNED BY THE LINCOLN ELECTRIC CO. AND IS NOT TO BE REPRODUCED OR USED IN ANY MANNER WITHOUT THE EXPRESS PERMISSION OF THE LINCOLN ELECTRIC CO.

FOR NA-5 CONTROL CODES  
 N.B. { 8400 9147  
 N.B. { 8993

**NOTE:** Lincoln Electric assumes no responsibility for liabilities resulting from board level troubleshooting. PC Board repairs will invalidate your factory warranty. **Individual Printed Circuit Board Components are not available from Lincoln Electric.** This information is provided for reference only. Lincoln Electric discourages board level troubleshooting and repair since it may compromise the quality of the design and may result in danger to the Machine Operator or Technician. Improper PC board repairs could result in damage to the machine.



CONTROL CIRCUIT SCHEMATIC

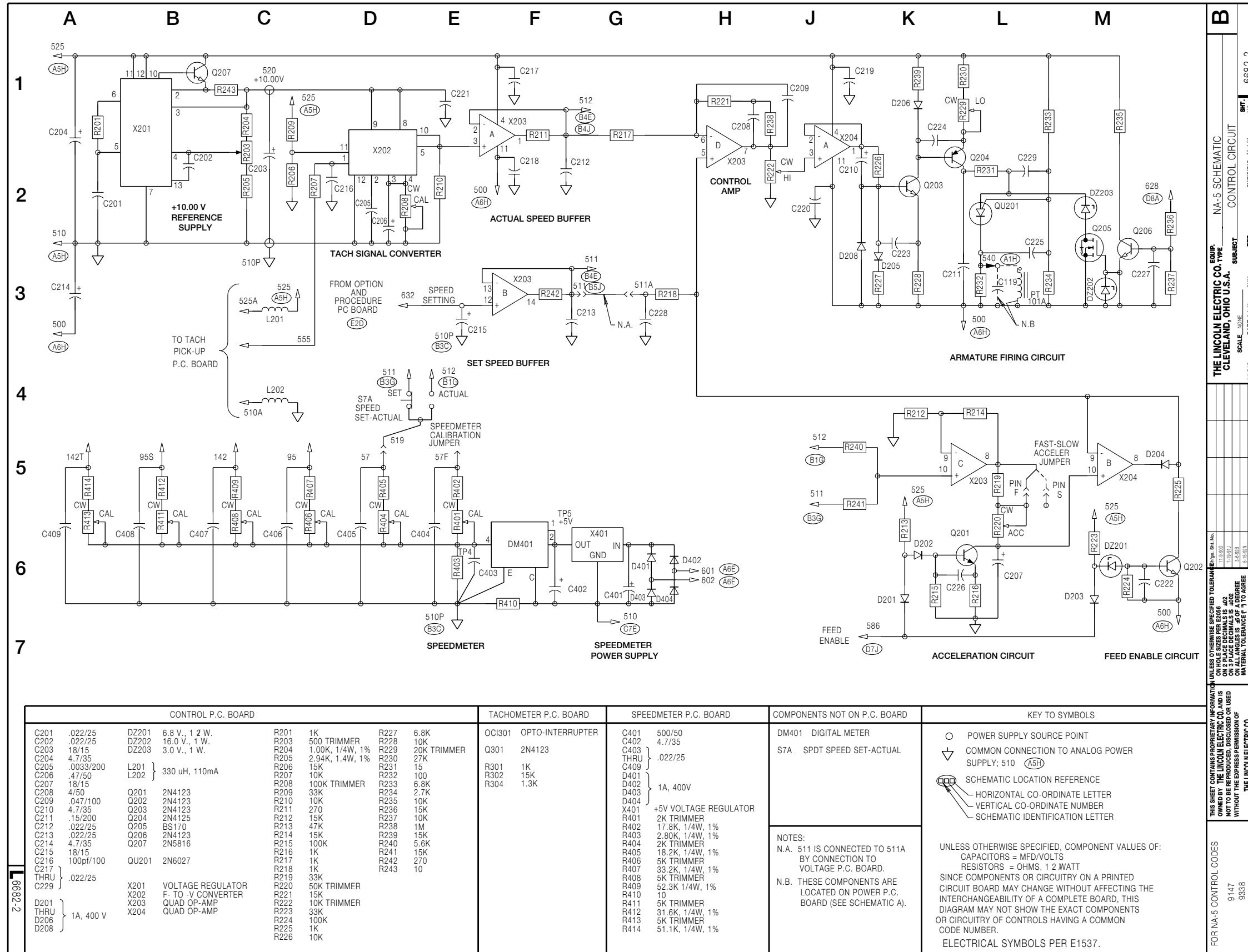

THE LINCOLN ELECTRIC CO. EQUIP. NA-5 SCHEMATIC CONTROL CIRCUIT  
 CLEVELAND, OHIO U.S.A. SUBJECT  
 SCALE NONE DATE 7-2-92 CHK REF. SUPERV. NO. 6682-2  
 DR. LOAD. DATE 7-2-92

**NOTE:** Lincoln Electric assumes no responsibility for liabilities resulting from board level troubleshooting. PC Board repairs will invalidate your factory warranty. **Individual Printed Circuit Board Components are not available from Lincoln Electric.** This information is provided for reference only. Lincoln Electric discourages board level troubleshooting and repair since it may compromise the quality of the design and may result in danger to the Machine Operator or Technician. Improper PC board repairs could result in damage to the machine.



PROCEDURE PC BOARD SCHEMATIC

Return to Section TOC  
Return to Master TOC

Return to Section TOC  
Return to Master TOC

Return to Section TOC  
Return to Master TOC

Return to Section TOC  
Return to Master TOC

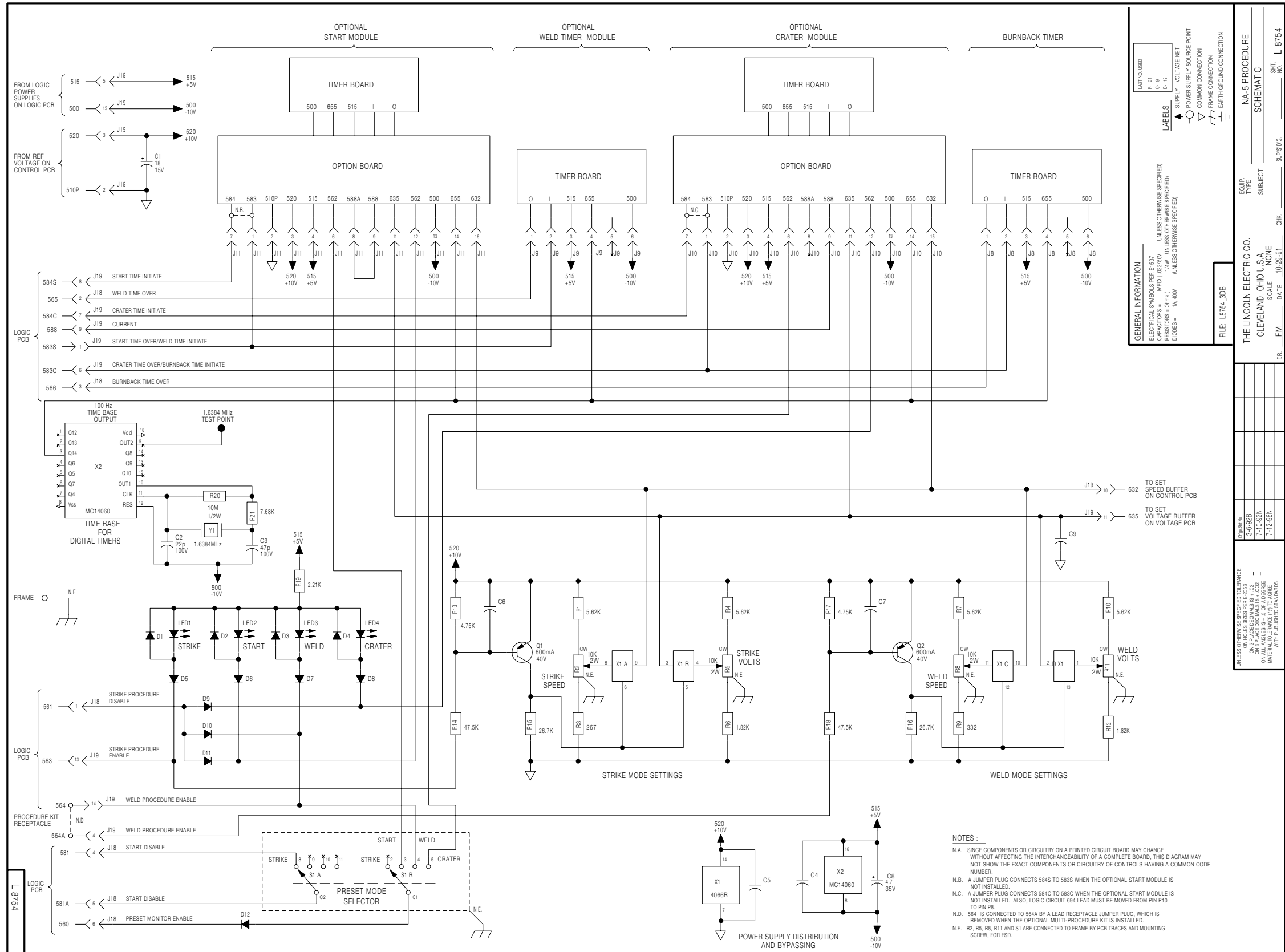

**NOTE:** Lincoln Electric assumes no responsibility for liabilities resulting from board level troubleshooting. PC Board repairs will invalidate your factory warranty. **Individual Printed Circuit Board Components are not available from Lincoln Electric.** This information is provided for reference only. Lincoln Electric discourages board level troubleshooting and repair since it may compromise the quality of the design and may result in danger to the Machine Operator or Technician. Improper PC board repairs could result in damage to the machine.





OPTION & TIMER PC BOARD SCHEMATICS

Return to Section TOC  
Return to Master TOC

Return to Section TOC  
Return to Master TOC

Return to Section TOC  
Return to Master TOC

Return to Section TOC  
Return to Master TOC

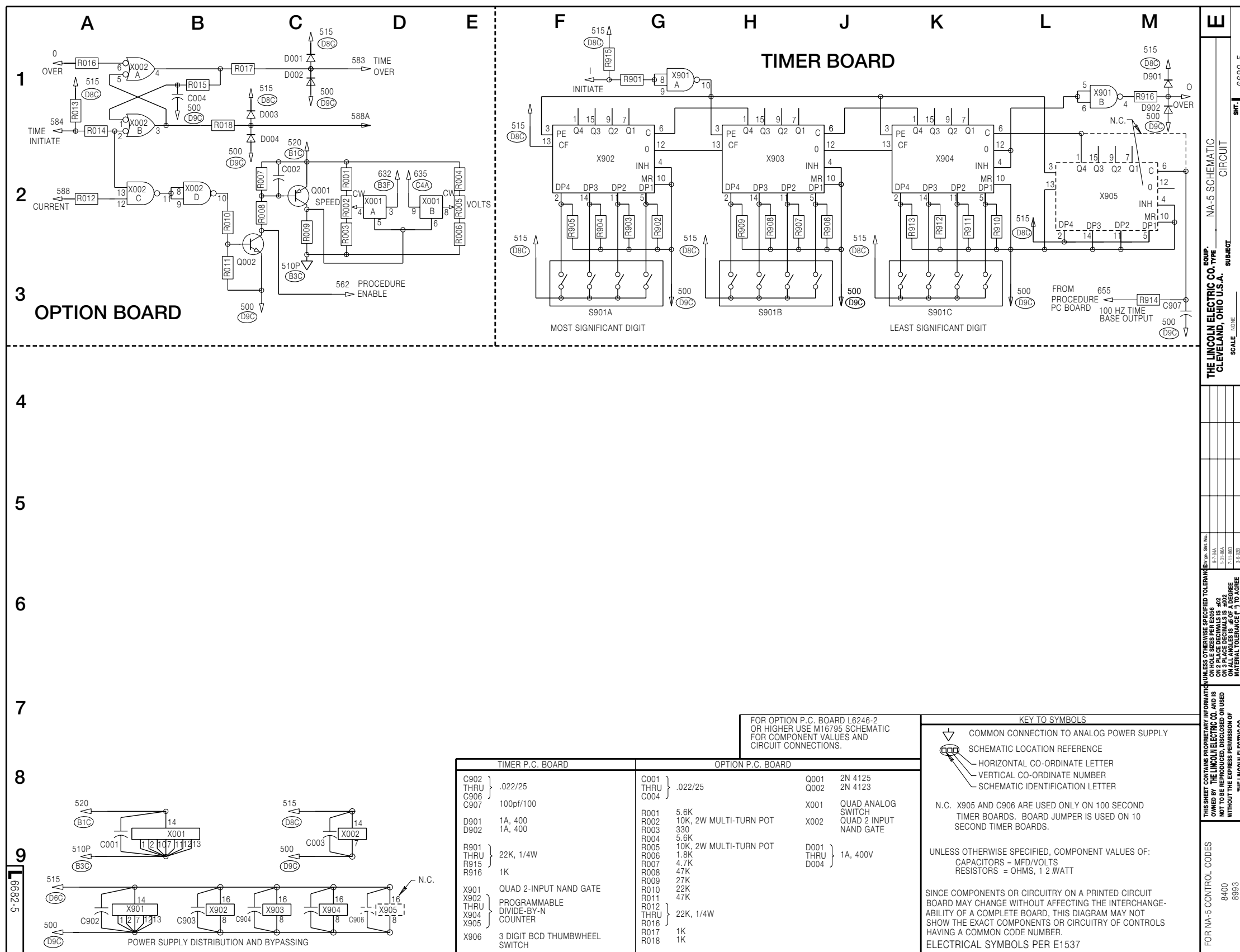

THE LINCOLN ELECTRIC CO. TYPE NA-5 SCHEMATIC CLEVELAND, OHIO U.S.A.

SCALE: NONE

DATE: 2-2-92

CHK: [Signature]

REF: [Signature]

SUPP'D TO: 6682-5

DRG. NO. 6682-5

THIS SHEET CONTAINS PROPRIETARY INFORMATION UNLESS OTHERWISE SPECIFIED TOLERANCES: DIMENSIONS: UNLESS OTHERWISE SPECIFIED TOLERANCES: .001 IN. MIN. ON HOLE SIZES PER E2658 .002 IN. MIN. ON 2 PLACE DECIMALS IS .002 ON ALL ANGLES IS 1/4 OF A DEGREE MATERIAL TOLERANCE IS TO AGREE WITH PUBLISHED STANDARDS.

NOT TO BE REPRODUCED, DISCLOSED OR USED WITHOUT THE EXPRESS PERMISSION OF THE LINCOLN ELECTRIC CO.

FOR NA-5 CONTROL CODES: 8400 8993

**NOTE:** Lincoln Electric assumes no responsibility for liabilities resulting from board level troubleshooting. PC Board repairs will invalidate your factory warranty. **Individual Printed Circuit Board Components are not available from Lincoln Electric.** This information is provided for reference only. Lincoln Electric discourages board level troubleshooting and repair since it may compromise the quality of the design and may result in danger to the Machine Operator or Technician. Improper PC board repairs could result in damage to the machine.



METER PC BOARD SCHEMATIC & LAYOUT

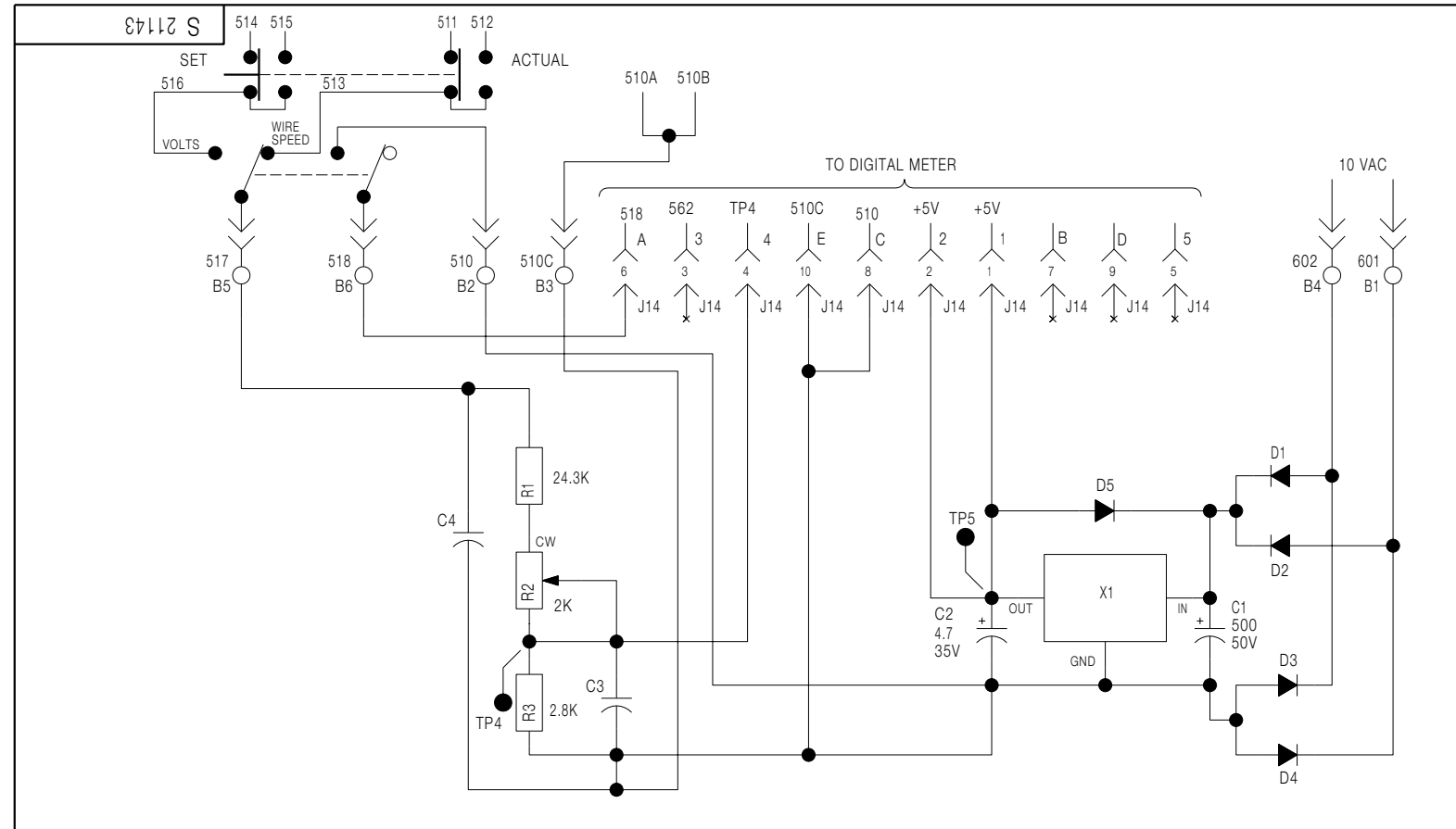

NOTES :  
 N.A. SINCE COMPONENTS OR CIRCUITRY ON A PRINTED CIRCUIT BOARD MAY CHANGE WITHOUT AFFECTING THE INTERCHANGEABILITY OF A COMPLETE BOARD. THIS DIAGRAM MAY NOT SHOW THE EXACT COMPONENTS OR CIRCUITRY OF CONTROLS HAVING A COMMON CODE NUMBER.

GENERAL INFORMATION  
 ELECTRICAL SYMBOLS PER E1537  
 CAPACITORS = MFD (.022/50V UNLESS OTHERWISE SPECIFIED)  
 RESISTORS = Ohms ( 1/4W UNLESS OTHERWISE SPECIFIED)  
 DIODES = 1A, 400V (UNLESS OTHERWISE SPECIFIED)

LABELS  
 ▲ SUPPLY VOLTAGE NET  
 ○ POWER SUPPLY SOURCE POINT  
 ▽ COMMON CONNECTION  
 ≡ FRAME CONNECTION  
 ⊥ EARTH GROUND CONNECTION

FILE: S21143\_1CA

UNLESS OTHERWISE SPECIFIED TOLERANCE ON HOLES SIZES PER E-2056  
 ON 2 PLACE DECIMALS IS + .02 -  
 ON 3 PLACE DECIMALS IS + .002 -  
 ON ALL ANGLES IS + .5 OF A DEGREE  
 MATERIAL TOLERANCE ("M") TO AGREE WITH PUBLISHED STANDARDS

Ch'ge Sht.No.					
3-25-94					

THE LINCOLN ELECTRIC CO. CLEVELAND, OHIO U.S.A.  
 SCALE NONE  
 DR. FM DATE 9-23-93 CHK. SUP'S'D'G. SHT. NO. S 21143

EQUIP. TYPE LN-9, LN-9F, NA-5  
 SUBJECT METER BOARD SCHEMATIC

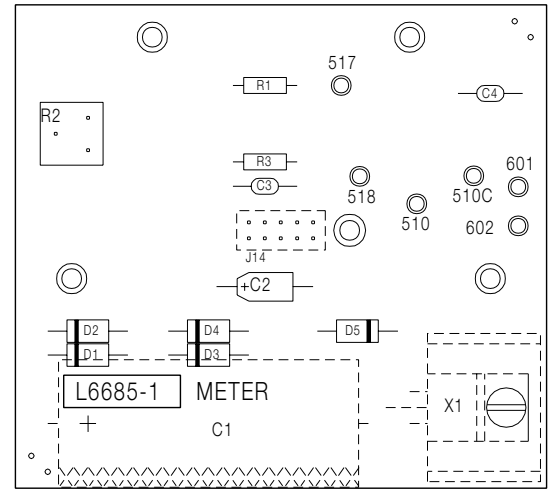

ITEM	REQ'D	PART NO.	IDENTIFICATION
C 1	1	T 11577-49	500/50
C2	1	S 13490-25	4.7/35
C3, C4	2	S 16668-5	.022/50
D 1, D2, D3, D4, D5	5	T 12199-1	1N4004
J 14	1	S 16626	P. C. BD. RECEPTACLE
R 1	1	S 19400-2432	24.3K 1/4W
R2	1	T 10812-73	2K 1/2W TRIMMER
R3	1	S 19400-2801	2.8K 1/4W
X 1	1	S 15128-5	L. E. CO. PART NO.

**NOTE:** Lincoln Electric assumes no responsibility for liabilities resulting from board level troubleshooting. PC Board repairs will invalidate your factory warranty. **Individual Printed Circuit Board Components are not available from Lincoln Electric.** This information is provided for reference only. Lincoln Electric discourages board level troubleshooting and repair since it may compromise the quality of the design and may result in danger to the Machine Operator or Technician. Improper PC board repairs could result in damage to the machine.



Return to Section TOC

MISCELLANEOUS PC BOARDS

POWER BOARD

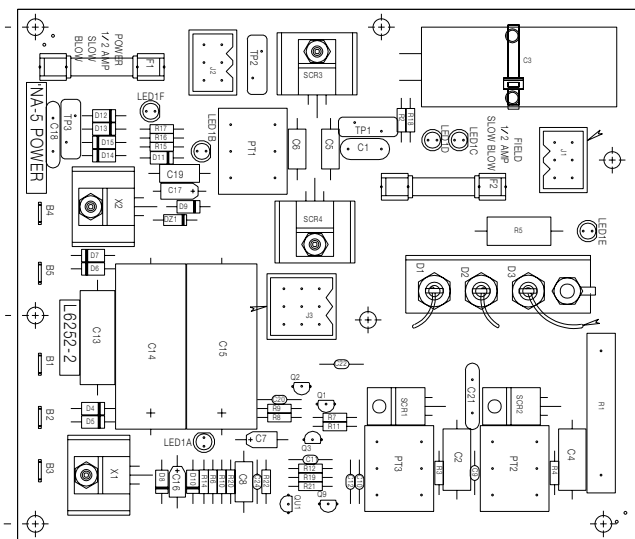

ITEM	REQ'D	PART NO.	IDENTIFICATION
C1	1	T11577-52	.0047 or .005/1400
C2, C4	2	S13490-96	.15/200
C3	1	S13490-86	50 MFD 250 V. CAPACITOR
C5, C6, C8, C19	4	S13490-102	.047/100
C7, C16	2	S13490-25	4.7/35
C9, C10, C11, C12, C20, C22, C24	7	S16668-5	.022/50
C13	1	T11577-28	.22/100
C14, C15	2	T11577-49	500/50
C17	1	S13490-39	18/15
C18, C21	2	T11577-38	.02/600
D4, D5, D6, D7, D8, D9, D10, D11	8	T12199-1	IN4004
D12, D13, D14, D15	4	T12199-2	IN4007
DZ1	1	T12702-52	IN4733
F1, F2	2	T10728-14	1/2 AMP SLOW BLOW FUSE
LED1A, LED1B, LED1C, LED1D LED1E, LED1F	6	T13657-2	RED LED
PT1, PT2, PT3	3	T12737-2	1: 1: 1
O1, O2, O3, O9	4	T12704-68	2N4401
QU1	1	T12707-4	2N6027
R1	1	T12300-59	40 OHM 12 WATT RESISTOR
R2, R16, R17, R18	4	S19400-1333	133K 1/4W
R3, R4, R6	3	S19400-1000	100 1/4W
R5	1	T12733-12	10K 2 WATT
R7	1	S19400-1002	10K 1/4W
R8, R12	2	S19400-4752	47.5K 1/4W
R9, R14	2	S19400-4751	4.75K
R10	1	S19400-6811	6.81K 1/4W
R11	1	S19400-6810	681 1/4W
R15	1	S19400-3321	3.32K 1/4W
R19	1	S19400-1501	1.5K 1/4W
R20	1	S19400-1372	13.7K 1/4W
R21	1	S19400-3320	332 1/4W
R22	1	S19400-3322	33.2K 1/4W
SCR1, SCR2	2	S15161-14	2N6398 SCR
SCR3, SCR4	2	S15161-10	SCR W/S14008-7 HS.
TP1, TP2, TP3	3	T13640-11	45J
X1	1	S15128-6	7815
X2	1	S15128-7	REGULATOR

CAPACITORS = MFD/VOLTS  
RESISTORES = OHMS

LOGIC BOARD

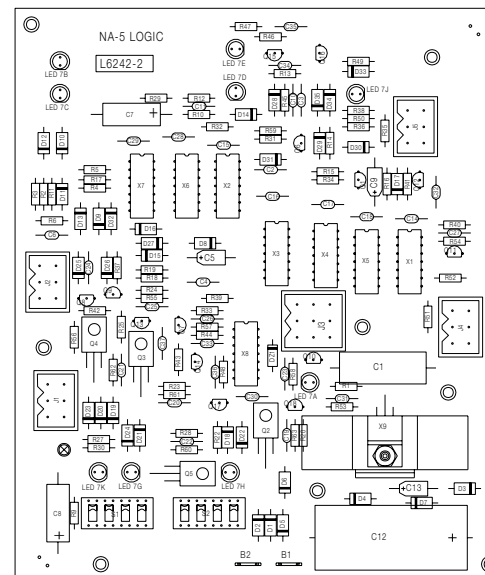

ITEM	REQ'D	PART NO.	IDENTIFICATION
B1, B2	2	T13157-14	TAB TERMINAL
C1	1	T11577-28	.22/100
C2, C3, C4, C6, C10, C11, C14 C15, C16, C17, C18, C19, C20 C21, C22, C23, C24, C25, C26 C27, C28, C29, C30, C31, C32 C33, C34, C35, C36, C37	30	S16668-5	.022/50
C5, C9, C13	3	S13490-25	4.7/35
C7, C8	2	S13490-12	10/25
C12	1	T11577-49	500/50
D1, D2, D3, D4, D5, D6, D7, D8, D9 D10, D11, D12, D13, D14, D15 D16, D17, D22, D23, D24, D25 D26, D27, D28, D29, D30, D31 D32, D33, D34, D35	31	T12199-1	IN4004
D18, D19, D20, D21	4	T12199-2	IN4007
DZ1	1	T12702-52	IN4733A
J1, J5	2	T13160-65	6 PIN PC BOARD HEADER
J2, J4	2	T13160-5	6 PIN RECEPTACLE
J3	1	T13160-3	9 PIN FEMALE RECEPTACLE
LED 7A, LED 7B, LED 7C LED 7D, LED 7E, LED 7G LED 7H, LED 7J, LED 7K	9	T13657-2	RED LED
O1, O6, O7, O8, O9, O10, O11, O15	8	T12704-68	2N4401
O2, O3, O4, O5	4	T12704-25	2N5657
O12, O13, O14, O16, O17, O18	6	T12704-69	2N4403
R1, R3, R11, R13, R38, R47	6	S19400-1501	1.5K 1/4W
R2, R5, R36	3	S19400-1001	1K 1/4W
R4, R9, R10, R14, R19, R32	6	S19400-4750	475 1/4W
R6, R12, R17, R35, R49, R50	6	S19400-1000	100 1/4W
R15	1	S19400-2213	221K 1/4W
R16	1	S19400-4752	47.5K 1/4W
R18, R24, R31, R33, R39, R42 R45, R51, R52	9	S19400-2212	22.1K 1/4W
R20, R23, R25, R28	4	S19400-2671	2.67K 1/4W
R22, R27, R30	3	S19400-6812	68.1K 1/4W
R29, R34	2	S19400-1502	15K 1/4W
R37	1	S19400-6811	6.81K 1/4W
R40	1	S19400-1002	10K 1/4W
R41, R43, R44, R46, R48, R53 R54, R55, R56, R57, R58, R59 R60, R61, R62, R63	10	S19400-1003	100K 1/4W

PROCEDURE BOARD

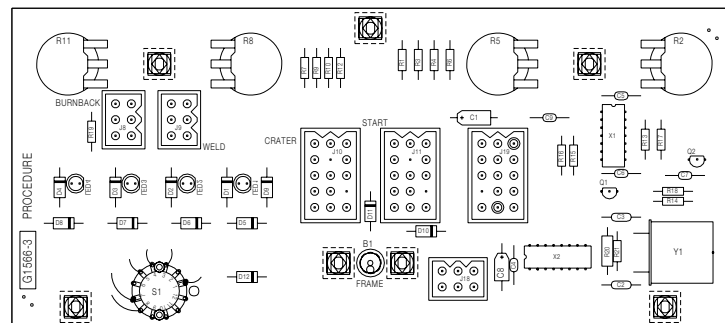

ITEM	REQ'D	PART NO.	IDENTIFICATION
B1	1	T15128-2	CAPTIVE NUT
C1	1	S13490-39	18/15
C2	1	S16668-1	22pF/100
C3	1	S16668-2	47pF/100
C4, C5, C6, C7, C9	5	S16668-5	.022/50
C8	1	S13490-25	4.7/35
D1, D2, D3, D4, D5, D6, D7, D8, D9, D10, D11, D12	12	T12199-1	IN4004
J8, J9, J18	3	T13160-65	6 PIN PC BD HEADER
J10, J11	2	T13160-115	HEADER
J19	1	T13160-119	HEADER
LED1, LED2, LED3, LED4	4	T13657-2	RED LED
O1, O2	2	T12704-69	2N4403
R1, R4, R7, R10	4	S19400-5621	5.62K 1/4W
R2, R5, R8, R11	4	S16296-6	10K POT
R3	1	S19400-2670	267 1/4W
R6, R12	2	S19400-1821	1.82K 1/4W
R9	1	S19400-3320	332 1/4W
R13, R17	2	S19400-4751	4.75K
R14, R18	2	S19400-4752	47.5K 1/4W
R15, R16	2	S19400-2672	26.7K 1/4W
R19	1	S19400-2211	2.21K 1/4W
R20	1	T14231-2	10M 1/2W
R21	1	S19400-7681	7.68K 1/4W
S1	1	S16670-1	ROTARY SWITCH
X1	1	S15018-6	DIG. INTEG. CIRCUIT (SS)
X2	1	S15018-17	16 PIN IC
Y1	1	S16665-7	1.6384 MHz

CAPACITORS = MFD/VOLTS

BYPASS BOARD

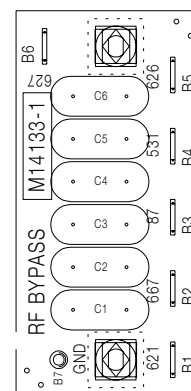

ITEM	REQ'D	PART NO.	DESCRIPTION
B1, B2, B3, B4, B5, B6	6	T13157-15	TAB TERMINAL
B7	1	CL001185	W-20A-4-96-144
C1, C2, C3, C4, C5, C6	6	T11577-58	.0047/3000V

CAPACITORS = MFD/VOLTS

Return to Section TOC  
Return to Master TOC

Return to Section TOC  
Return to Master TOC

Return to Section TOC  
Return to Master TOC

Return to Section TOC  
Return to Master TOC