

LN-7 and LN-7 GMA

Semiautomatic, Constant Speed Wire Feeders

The LN-7 and LN-7 GMA are semiautomatic constant speed wire feeders that can be used with a variety of Lincoln engine drives, DC or CV power sources in a shop or field environment. Both models and a Ready-Pak™ package feature Lincoln's unique drive roll design, which provides positive feeding, quick reloading and durability for long life. Controlled wire feed speed during starting provides clean, positive starts and minimizes stubbing, skipping and spatter. For dependable operation and precise wire feeding in a rugged package, choose the LN-7 or LN-7 GMA.



Shown with options

Processes

MIG Flux-Cored Submerged Arc⁽¹⁾

Advantage Lincoln

- The LN-7 feeds up to 3/32" (2.4mm) solid and 7/64" (2.8mm) flux-cored wires, from 50-500 inches per minute (1.3-12.7m/min) wire feed speed.
- The LN-7 GMA feeds up to 1/16" (1.6mm) solid and 5/64" (2.0mm) flux-cored wires, from 75-700 inches per minute (1.9-17.8 m/min) wire feed speed.
- Unique drive roll design provides positive feeding and quick reloading by simply starting wire into guide tube. The drive rolls and guide tubes are designed for long life and precise wire feeding.
- Four-roll wire drive system available for additional wire feeding force and easier feeding of soft wires (LN-7 GMA model only).
- Completely enclosed case protects the heavy duty wire drive mechanism from damage, but allows easy access to drive rolls.
- Control circuit features "cold electrode" when the gun trigger is released for an added measure of safety.
- Low voltage (24 volts) gun trigger circuit.
- Dynamic braking system stops wire feed motor quickly to minimize crater sticking problems.
- Three-year warranty on parts and labor.

Description

Output  Input  115 VAC

Required Options

Gun and Cable Assembly, Drive Roll Kit, Control Cable, Weld Power Cable

Recommended General Options

Universal Wire Reel Stand, Insulated Lift Bail, Caster Kit, Swivel Platform, Spindle Adapter, Readi-Reel Adapter, Coil Adapter, Plastic Wire Cover, Digital Voltmeter, Water Solenoid Kit, Gas Solenoid Assembly, Gas Guard Regulator, GMA Timer Kit, Burnback Kit, Magnetic Flux Screen Separator, Flux Screen, Continuous Flux Feeding Tank Assembly, Undercarriage, Remote Output Control Kit, Remote Control Adapter

Recommended Power Source Options

CV-250, CV-300, CV400-I, CV-400, CV500-I, CV-655, V350-PRO, DC-400, DC-600, DC-655, DC-1000

Order

K521 LN-7 Wire Feeder (2 Roll)
 K440-2 LN-7 GMA (2 Roll) with gas solenoid valve
 K567-2 LN-7 GMA (4 Roll) with gas solenoid valve
 K1801-1 LN-7 GMA (2 Roll) Ready-Pak™ Wire Feeder

TECHNICAL SPECIFICATIONS

Product Name	Product Number	Input Power	Rated Output Current / Duty Cycle	Wire Feed Speed Range ipm (m/min)	Wire Size Range in. (mm)		Dimensions H x W x D in. (mm)	Net Weight lbs. (kg)
					Solid	Cored		
LN-7 (2 Roll)	K521	115 VAC 50/60 Hz 2.5 Amps	600 Amps @ 60%	50-500 (1.3-12.7)	.023-3/32 (0.6-2.4)	.045-7/64 (1.2-2.8)	10.9 x 9.8 x 9.6 (277 x 249 x 244)	24 (10.9)
LN-7 GMA (2 Roll)	K440-2			75-700 (1.9-17.8)	.023-1/16 (0.6-1.6)	.045-5/64 (1.2-2.0)		
LN-7 GMA (4 Roll)	K567-2			75-700 (1.9-17.8)	.023-1/16 (0.6-1.6)	.045-5/64 (1.2-2.0)	11.1 x 11.6 x 9.7 (282 x 295 x 246)	32 (13.8)

(1) LN-7 model only.

PERFORMANCE

- Easy wire feeding with standard 2-roll or optional 4-roll wire drive system.
- Unique drive roll design provides positive feeding and quick reloading by simply starting wire into guide tube. The drive rolls and guide tubes are designed for long life and precise wire feeding.
- Dynamic braking system stops wire feed motor quickly to minimize crater sticking problems.
- Solid state control compensates for wire drag and input line variations to maintain accurate wire feed speed.

FEATURES

- Tool-less quick release wire drive tension system and gun cable connections for easy wire or gun changes.
- Can be boom mounted or add optional Universal Wire Reel Stand, casters and/or swivel platform and mount on power source for extra versatility.
- Optional time controls for pre-flow and post-flow gas, burnback, as well as cold inch and gas purge control.
- Optional digital display is easy to read in bright sunlight or dark working conditions.
- Compatible with many Lincoln power sources including the CV-250, CV-300, CV400-I, CV500-I, CV-655, V350-PRO, DC-400, DC-600, DC-655, DC-1000, Ranger 250®, Ranger 250 LPG, Ranger 305G, Ranger 305D, Classic® II, Classic 300G, Classic 300D, Commander® 300, Vantage® 500, Air Vantage® 500.



Optional time controls for pre-flow and post-flow gas, burnback, as well as cold inch and gas purge control.

QUALITY AND RELIABILITY

- Control circuit features "cold electrode" when the gun trigger is released for an added measure of safety.
- Completely enclosed case protects the heavy duty wire drive mechanism from damage, yet allow easy access to rolls.
- Rugged and durable design recognized throughout the industry for its long life and years of trouble-free wire feeding.
- Manufactured under a quality system certified to ISO 9001 requirements.
- Three-year warranty on parts and labor.

SYSTEM SELECTION

Ready-Pak™ Packages

Take the hassle out of ordering - Order a Ready-Pak™ pre-assembled welding package.

LN-7 GMA 2-Roll Ready-Pak™ Wire Feeder Package

Order K1801-1

- Universal Wire Reel Stand
- 10 ft. Control Cable
- .035-.052 Drive Roll
- Guide Tube Kit



LN-7 GMA (2 roll) Ready-Pak Wire Feeder Package (K1801-1)

INPUT CABLE SELECTION GUIDE

Connections are for current equipment design. Subject to change without notice.

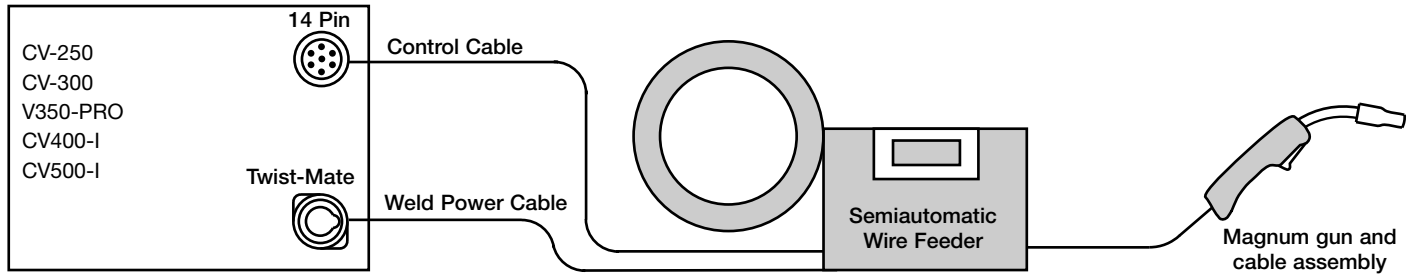

Control Cables

K1818-10 Wire Feeder Control Cable -10 ft.

Extensions

K1797-25 14-pin Extension Control Cable - 25 ft.

K1797-50 14-pin Extension Control Cable - 50 ft.

Weld Power Cables

K1840-10 Twist-Mate to Lug, 1/0, 350A, 60% Duty Cycle -10 ft.

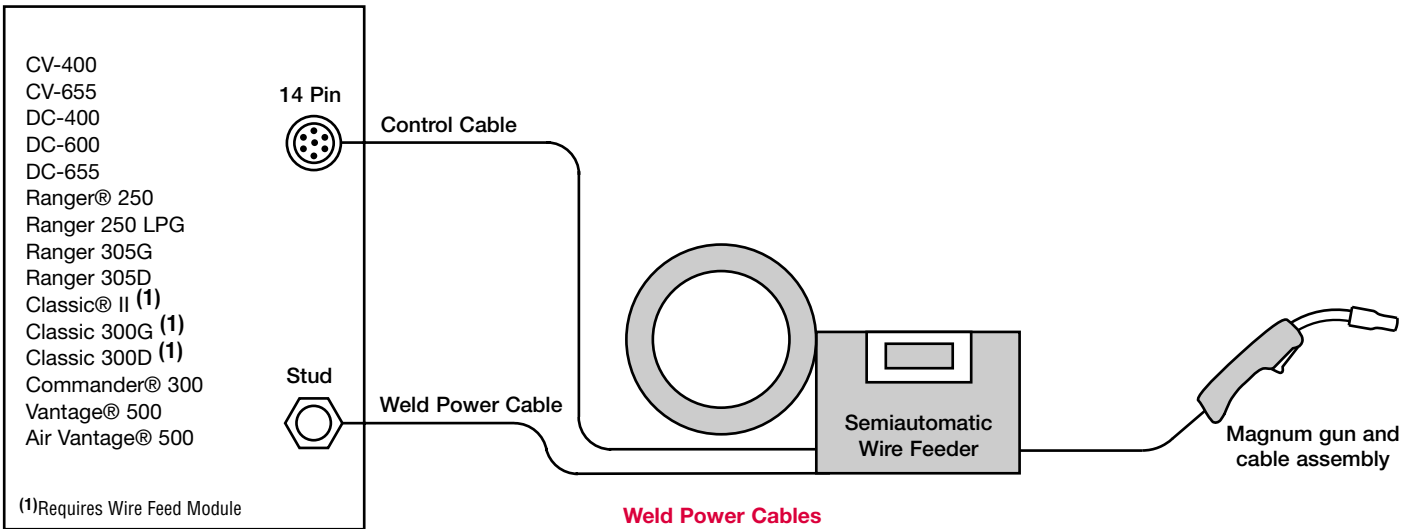

(1)Requires Wire Feed Module

Control Cables

K1818-10 Wire Feeder Control Cable -10 ft.

Extensions

K1797-25 14-pin Extension Control Cable - 25 ft.

K1797-50 14-pin Extension Control Cable - 50 ft.

Weld Power Cables

K1842-10 Lug to Lug, 3/0, 600A, 60% Duty Cycle - 10 ft.

K1842-35 Lug to Lug, 3/0, 600A, 60% Duty Cycle - 35 ft.

K1842-60 Lug to Lug, 3/0, 600A, 60% Duty Cycle - 60 ft.

K1842-110 Lug to Lug, 3/0, 600A, 60% Duty Cycle - 110 ft.

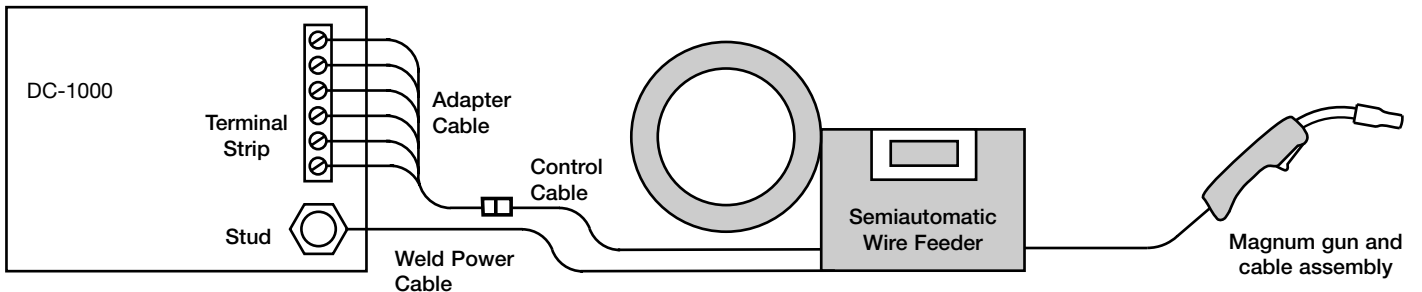

Control Cables

K1818-10 Wire Feeder Control Cable -10 ft.

K1798 Adapter Cable - 14-pin to Terminal Strip

Extensions

K1797-25 14-pin Extension Control Cable - 25 ft.

K1797-50 14-pin Extension Control Cable - 50 ft.

Weld Power Cables

K1842-10 Lug to Lug, 3/0, 600A, 60% Duty Cycle - 10 ft.

K1842-35 Lug to Lug, 3/0, 600A, 60% Duty Cycle - 35 ft.

K1842-60 Lug to Lug, 3/0, 600A, 60% Duty Cycle - 60 ft.

K1842-110 Lug to Lug, 3/0, 600A, 60% Duty Cycle - 110 ft.

REMOTE OUTPUT CONTROL SELECTION GUIDE

Connections are for current equipment design. Subject to change without notice.

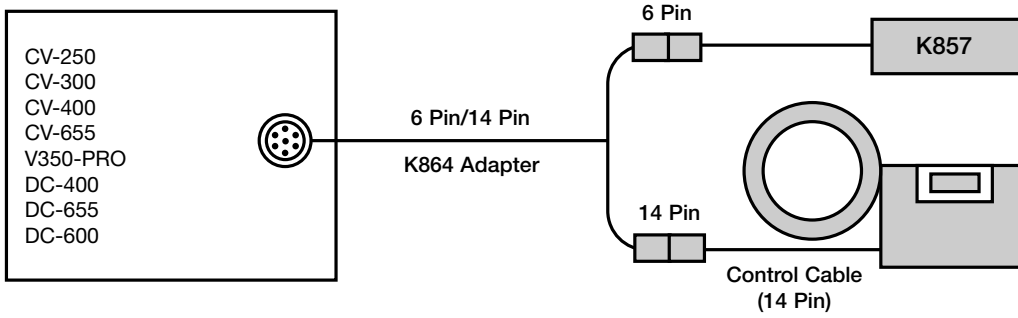
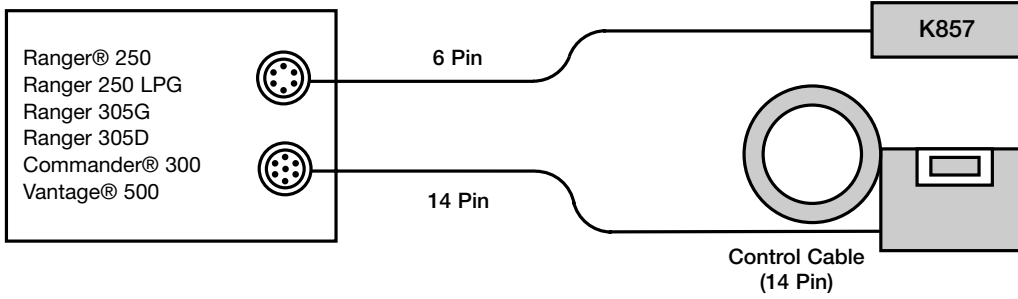

RECOMMENDED OPTIONS

REQUIRED OPTIONS

DRIVE ROLL AND GUIDE TUBE KITS

Steel Wire Sizes:	2 Roll	4 Roll
Solid Wire: .023 - .025" (0.6 - 0.9 mm) .030 (.8 mm) .035-.040 (0.9-1.0 mm) .045-.052 (1.2-1.4 mm)	KP653-025S KP653-030S KP653-035S KP653-052S	KP655-025S KP655-030S KP655-035S KP655-052S
Cored Wire: .035" (0.9 mm) .045-.052 (1.2-1.4 mm) 7/64 - .120" (2.8 - 3.0 mm)	KP653-035C KP653-052C KP653-120C	KP655-035C KP655-052C KP655-120C
Solid or Cored Wire: 1/16" (1.6mm) .068 - 3/32" (1.7 - 2.4 mm)	KP653-1/16 KP653-3/32 (1)	KP655-1/16 KP655-3/32
Hardfacing: 7/64" (2.8 mm)	KP653-7/64H	-
Aluminum Wire: .035" (0.9mm) 3/64" (1.2mm) 1/16" (1.6mm)	KP654-035A KP654-3/64A KP654-1/16A	KP656-035A KP656-3/64A KP656-1/16A
Clutched Aluminum Wire: .035" (0.9mm) 3/64" (1.2mm) 1/16" (1.6mm) 1.0 mm	KP1682-035A KP1682-3/64A KP1682-1/16A KP1682-1.0A	- - - -

(1) For LN-7 only.

CONTROL CABLES

Cable Type	Description
Wire Feeder Control Cable K1818-10	Male 9 pin to female 14 pin
Wire Feeder Control Cable Extensions K1797-25 - 25 ft. K1797-50 - 50 ft.	Male 14 pin to female 14 pin
Adapter Cable for Control Cable to Terminal Strip Power Sources K1798	14 pin control cable to Terminal Strip

WELD POWER CABLES

Order No.	Description
K1840-10	Twist-Mate™ to Lug, 1/0, 350A, 60% duty cycle, 10 ft.
K1842-10	Lug to Lug, 3/0, 600A, 60% duty cycle, 10 ft.
K1842-35	Lug to Lug, 3/0, 600A, 60% duty cycle, 35 ft.
K1842-60	Lug to Lug, 3/0, 600A, 60% duty cycle, 60 ft.
K1842-110	Lug to Lug, 4/0, 600A, 60% duty cycle, 110 ft.



Magnum 400 shown

Magnum Gas-Shielded Gun and Cable Assemblies

Available 200-550 amps, air-cooled, gas-shielded welding guns.

See publication E12.10



K126 Innershield Gun shown

Magnum Self-Shielded Gun and Cable Assemblies

Available 250-600 amps.

See publication E12.110



Magnum Submerged Arc Gun
Rated 500 amps, 15 ft. (4.5m) cable, for 1/16" (1.6mm) electrode size.

Order K112



Magnum Submerged Arc Gun

Rated 600 amps, 15 ft. (4.5m) cable, for 5/64" (2.0mm) electrode size.

Order K113-1



Magnum Submerged Arc Gun

Rated 600 amps, 15 ft. (4.5m) cable, for 3/32" (2.4mm) electrode size.

Order K113-2



Flux Cone

Fits K112 and K113 submerged arc guns for welding without the Continuous Flux Feed Tank Assembly.

Order K119

GENERAL OPTIONS



Universal Wire Reel Stand
For use with Lincoln 10-60 lb. (4.5-27.2 kg) wire packages that use a 2" (51mm) spindle. Hole in stand fits over lift bail.
Order K1524-1



Insulated Lift Bail
Allows the entire wire feeder to be hung from a crane or hook. Use with K1524-1.
Order K1555-1



Caster Kit - Light Duty
Mounts to the K1524-1 wire reel stand. Allows for easy movement of wire feeder.
Order K1556-1



Swivel Platform
Mounts to the lift bail on the power source and bottom of the K1524-1. Wire feeder may be lifted off if needed. Compatible with Light Duty Caster Kit. Includes "lazy susan" parts tray.
Order K1557-1



Spindle Adapter for Readi-Reels® and Spools
2" O.D. spindle for mounting Readi-Reels and 2" (51mm) I.D. spools up to 60 lb. (27.2 kg) capacity to custom installations.
Order K162-1



14 lb. Innershield® Coil Adapter
Permits 14 lb. (6 kg) Innershield electrode coils to be mounted on 2" (51 mm) O.D. spindles.
Order K435



8" O.D. Spool Adapter
Permits 8" (200mm) O.D. spools to be mounted on 2" (51mm) O.D. spindles.
Order K468

GENERAL OPTIONS CONT.



22-30 lb. Readi-Reel® Adapter
Adapts 22-30 lb. (10-14 kg) Lincoln Readi-Reels of electrode to 2" (51mm) spindle.
Order K363P



50-60 lb. Readi-Reel® Adapter
Adapts 60 lb. (27.2 kg) coils of Lincoln electrode to 2" (51mm) spindle.
Order K438



50-60 lb. Coil Adapter
Adapts 50-60 lb. (22.6-27.2 kg) coils of Lincoln electrode to 2" (51mm) spindle.
Order K1504-1



Plastic Wire Cover
Plastic enclosure for up to 60 lb. (27.2kg) wire packages.
Order K1634-2



Digital Voltmeter
Includes digital display, meter polarity switch and hold feature for easy checking of procedure.
Order K417



Water Solenoid Kit
Includes solenoid valve, mounting bracket and quick disconnect gun and cable hose water connection.
Order K527



Gas Solenoid Assembly
Includes solenoid valve and mounting bracket. For LN-7 (K521) model only.
Order K494



Gas Guard Regulator
For CO₂ and argon blend gases. Reduces surge caused by excess pressure in supply hose. Includes adjustable flow regulator with removable adjustor key.
Order K659-1

GENERAL OPTIONS CONT.



GMA Timer Kit

Provides delays for preflow and postflow gas, adjustable burnback, and a purge/cold inch switch. For LN-7 GMA only.

Order K418



Burnback Kit

Provides adjustable delay of power source output shut off to prevent electrode sticking in crater when using high wire feed speeds. Includes a cold inch switch.

Order K419



Magnetic Flux Screen Separator

For submerged arc welding. Removes foreign magnetic particles from reused flux.

Order K58



Flux Screen

For submerged arc welding. Removes large particles from reused flux. Includes air-driven vibrator.

Order K310



Continuous Flux Feeding Tank Assembly

For submerged arc welding. Includes air filter, pressure regulator, gauge, tank, 18 ft. (5.4m) flux hose, funnel and lift bail assembly to mount wire feeder.

Order K320



Undercarriage

Includes mounting frame, front casters, rear wheels and handle for hand towing. For use with Wire Reel Stand.

Order K163



Remote Output Control Kit

Consists of a control box with four conductor cable and 6 pin MS-type connector.

Order:

K857 for 25 ft. cable

K857-1 for 100 ft. cable

GENERAL OPTIONS CONT.



Remote Control Adapter

Y connection adapter for connecting Lincoln 6 pin plug K857 remote output control kit and 14 pin input cable assemblies to power sources with a 14 pin receptacle.

Order K864

LN-7 AND LN-7 GMA ORDER FORM

PRODUCT DESCRIPTION	ORDER NUMBER	QUANTITY	PRICE
LN-7 WIRE FEEDER (2 Roll)	K521		
LN-7 GMA (2 Roll) with gas solenoid valve	K440-2		
LN-7 GMA (4 Roll) with gas solenoid valve	K567-2		
LN-7 GMA (2 Roll) Ready-Pak Wire Feeder Package	K1801-1		
REQUIRED OPTIONS			
Magnum Gas-Shielded Gun and Cable Assemblies	see publication E12.10		
Magnum Self-Shielded Gun and Cable Assemblies	see publication E12.110		
Submerged Arc Gun and Cable Assemblies	see page 5		
Drive Roll and Guide Tube Kits	see page 5		
Control Cable	see page 5		
Weld Power Cable	see page 5		
RECOMMENDED GENERAL OPTIONS			
Universal Wire Reel Stand	K1524-1		
Insulated Lift Bail	K1555-1		
Caster Kit - Light Duty	K1556-1		
Swivel Platform	K1557-1		
Spindle Adapter for Readi-Reels and Spools	K162-1		
14 lb. Innershield Coil Adapter	K435		
8" O.D. Spool Adapter	K468		
22-30 lb. Readi-Reel Adapter	K363P		
50-60 lb. Readi-Reel Adapter	K438		
50-60 lb. Coil Adapter	K1504-1		
Plastic Wire Cover (for up to 60 lb. wire packages)	K1634-2		
Digital Voltmeter	K417		
Water Solenoid Kit	K527		
Gas Solenoid Assembly	K494		
Gas Guard Regulator	K659-1		
GMA Timer Kit	K418		
Burnback Kit	K419		
Magnetic Flux Screen Separator	K58		
Flux Screen	K310		
Continuous Flux Feeding Tank Assembly	K320		
Undercarriage	K163		
Remote Output Control Kit - for 25 ft. cable	K857		
- for 100 ft. cable	K857-1		
Remote Control Adapter	K864		
RECOMMENDED POWER SOURCE OPTIONS			
CV-250	see publication E4.10		
CV-300	see publication E4.20		
CV400-I	see publication E4.20.1		
CV-400	see publication E4.30		
CV500-I	see publication E4.30.1		
CV-655	see publication E4.40		
V350-PRO	see publication E5.91		
DC-400	see publication E5.20		
DC-600	see publication E5.40		
DC-655	see publication E5.46		
DC-1000	see publication E5.50		
	TOTAL:		

CUSTOMER ASSISTANCE POLICY

The business of The Lincoln Electric Company is manufacturing and selling high quality welding equipment, consumables, and cutting equipment. Our challenge is to meet the needs of our customers and to exceed their expectations. On occasion, purchasers may ask Lincoln Electric for advice or information about their use of our products. We respond to our customers based on the best information in our possession at that time. Lincoln Electric is not in a position to warrant or guarantee such advice, and assumes no liability, with respect to such information or advice. We expressly disclaim any warranty of any kind, including any warranty of fitness for any customer's particular purpose, with respect to such information or advice. As a matter of practical consideration, we also cannot assume any responsibility for updating or correcting any such information or advice once it has been given, nor does the provision of information or advice create, expand or alter any warranty with respect to the sale of our products.

Lincoln Electric is a responsive manufacturer, but the selection and use of specific products sold by Lincoln Electric is solely within the control of, and remains the sole responsibility of the customer. Many variables beyond the control of Lincoln Electric affect the results obtained in applying these types of fabrication methods and service requirements.

Subject to Change - This information is accurate to the best of our knowledge at the time of printing. Please refer to www.lincolnelectric.com for any updated information.



THE LINCOLN ELECTRIC COMPANY

22801 St. Clair Ave., Cleveland, OH 44117-1199 • 216.481.8100 • www.lincolnelectric.com