

# RANGER 305G MACHINE SCHEMATIC L15763 REV: C

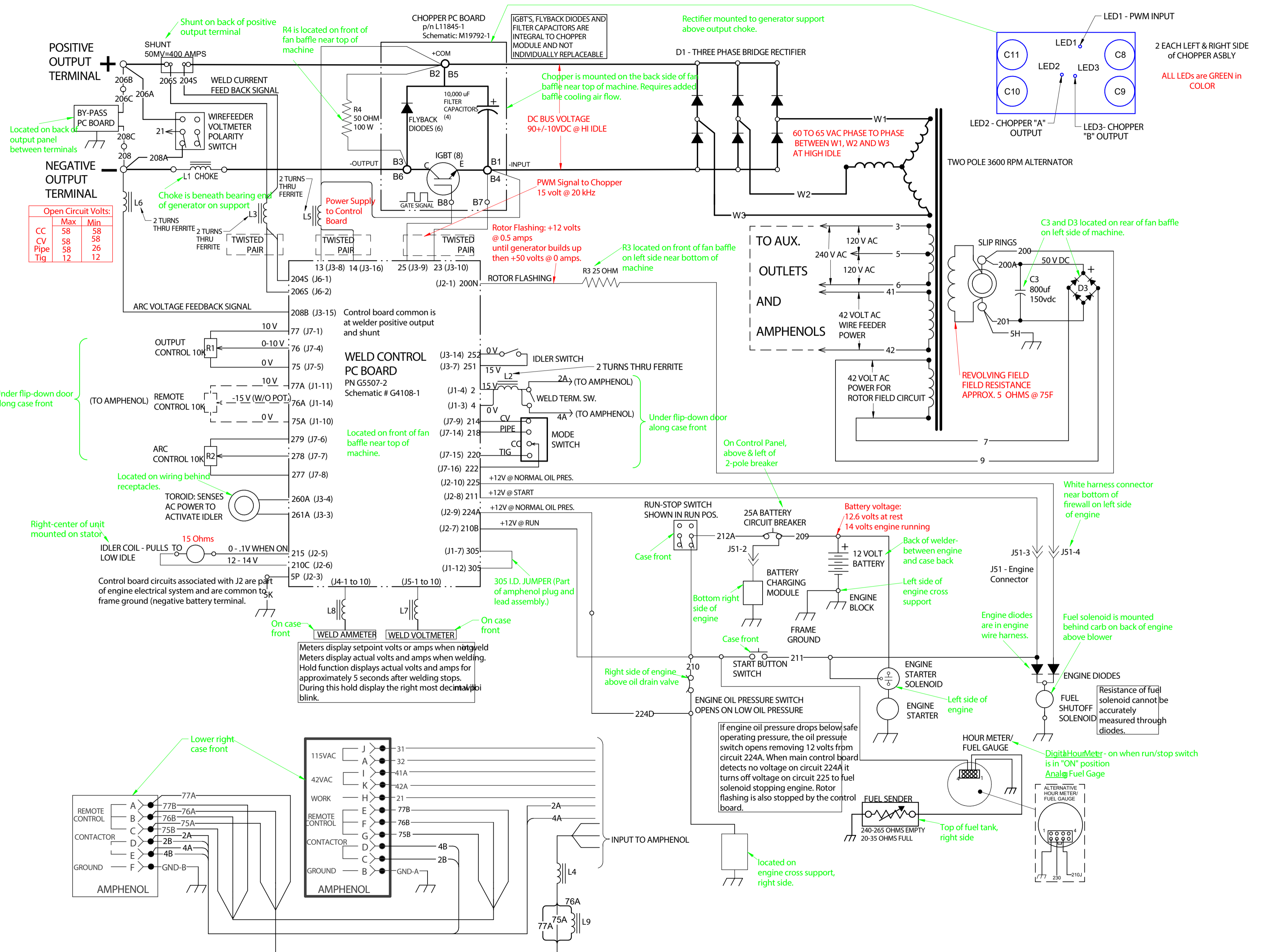

# RANGER 305G MACHINE SCHEMATIC L15763 REV: C PAGE 2

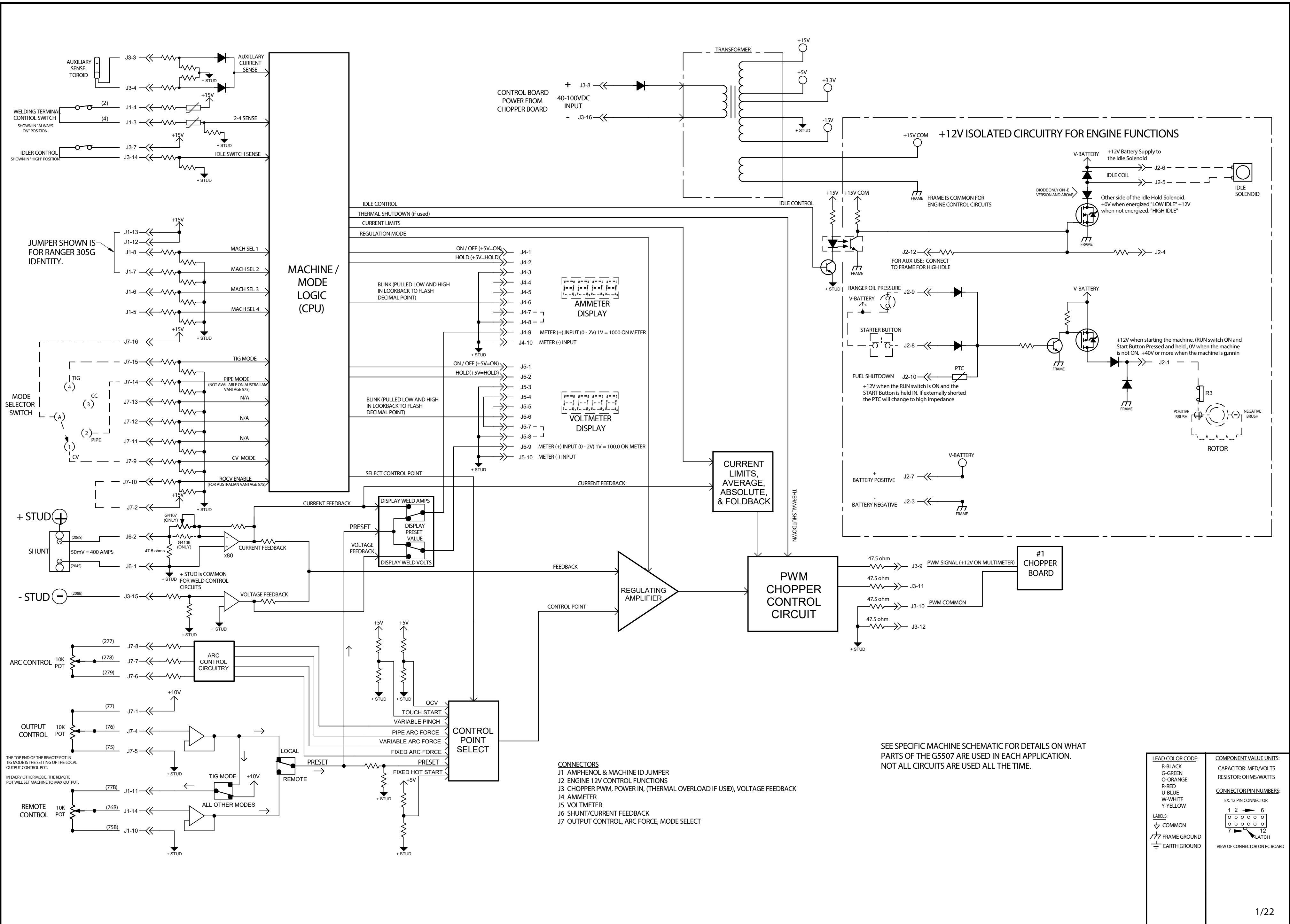

- CONNECTORS**
- J1 AMPHENOL & MACHINE ID JUMPER
  - J2 ENGINE 12V CONTROL FUNCTIONS
  - J3 CHOPPER PWM, POWER IN, (THERMAL OVERLOAD IF USED), VOLTAGE FEEDBACK
  - J4 AMMETER
  - J5 VOLTMETER
  - J6 SHUNT/CURRENT FEEDBACK
  - J7 OUTPUT CONTROL, ARC FORCE, MODE SELECT

SEE SPECIFIC MACHINE SCHEMATIC FOR DETAILS ON WHAT PARTS OF THE G5507 ARE USED IN EACH APPLICATION. NOT ALL CIRCUITS ARE USED ALL THE TIME.

LEAD COLOR CODE:	COMPONENT VALUE UNITS:
B-BLACK	CAPACITOR: MFD/VOLTS
G-GREEN	RESISTOR: OHMS/WATTS
O-ORANGE	
R-RED	
U-BLUE	
W-WHITE	
Y-YELLOW	
<b>CONNECTOR PIN NUMBERS:</b>	
EX 12 PIN CONNECTOR	
VIEW OF CONNECTOR ON PCB BOARD	