



NOTE: This manual will cover most of the troubleshooting and repair procedures for the code numbers listed. Some variances may exist when troubleshooting/repairing later code numbers.

POWER MIG[®] 300

For use with machines having Code Numbers:

10562, 10952, 10958, 11000, 11097, 11098

SERVICE MANUAL

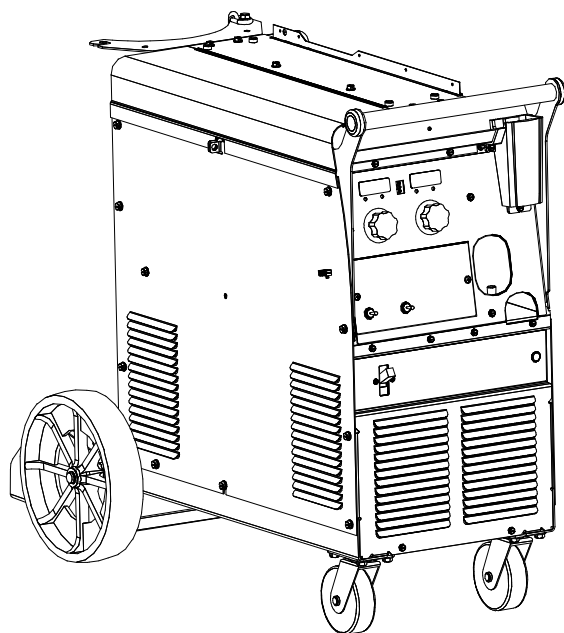

⚠ WARNING

⚠ CALIFORNIA PROPOSITION 65 WARNINGS ⚠

Diesel engine exhaust and some of its constituents are known to the State of California to cause cancer, birth defects, and other reproductive harm.

The Above For Diesel Engines

The engine exhaust from this product contains chemicals known to the State of California to cause cancer, birth defects, or other reproductive harm.

The Above For Gasoline Engines

ARC WELDING can be hazardous. PROTECT YOURSELF AND OTHERS FROM POSSIBLE SERIOUS INJURY OR DEATH. KEEP CHILDREN AWAY. PACEMAKER WEARERS SHOULD CONSULT WITH THEIR DOCTOR BEFORE OPERATING.

Read and understand the following safety highlights. For additional safety information, it is strongly recommended that you purchase a copy of "Safety in Welding & Cutting - ANSI Standard Z49.1" from the American Welding Society, P.O. Box 351040, Miami, Florida 33135 or CSA Standard W117.2-1974. A Free copy of "Arc Welding Safety" booklet E205 is available from the Lincoln Electric Company, 22801 St. Clair Avenue, Cleveland, Ohio 44117-1199.

BE SURE THAT ALL INSTALLATION, OPERATION, MAINTENANCE AND REPAIR PROCEDURES ARE PERFORMED ONLY BY QUALIFIED INDIVIDUALS.



FOR ENGINE powered equipment.

1.a. Turn the engine off before troubleshooting and maintenance work unless the maintenance work requires it to be running.



1.b. Operate engines in open, well-ventilated areas or vent the engine exhaust fumes outdoors.



1.c. Do not add the fuel near an open flame welding arc or when the engine is running. Stop the engine and allow it to cool before refueling to prevent spilled fuel from vaporizing on contact with hot engine parts and igniting. Do not spill fuel when filling tank. If fuel is spilled, wipe it up and do not start engine until fumes have been eliminated.

1.d. Keep all equipment safety guards, covers and devices in position and in good repair. Keep hands, hair, clothing and tools away from V-belts, gears, fans and all other moving parts when starting, operating or repairing equipment.

1.e. In some cases it may be necessary to remove safety guards to perform required maintenance. Remove guards only when necessary and replace them when the maintenance requiring their removal is complete. Always use the greatest care when working near moving parts.



1.f. Do not put your hands near the engine fan. Do not attempt to override the governor or idler by pushing on the throttle control rods while the engine is running.

1.g. To prevent accidentally starting gasoline engines while turning the engine or welding generator during maintenance work, disconnect the spark plug wires, distributor cap or magneto wire as appropriate.



1.h. To avoid scalding, do not remove the radiator pressure cap when the engine is hot.



ELECTRIC AND MAGNETIC FIELDS may be dangerous

2.a. Electric current flowing through any conductor causes localized Electric and Magnetic Fields (EMF). Welding current creates EMF fields around welding cables and welding machines

2.b. EMF fields may interfere with some pacemakers, and welders having a pacemaker should consult their physician before welding.

2.c. Exposure to EMF fields in welding may have other health effects which are now not known.

2.d. All welders should use the following procedures in order to minimize exposure to EMF fields from the welding circuit:

2.d.1. Route the electrode and work cables together - Secure them with tape when possible.

2.d.2. Never coil the electrode lead around your body.

2.d.3. Do not place your body between the electrode and work cables. If the electrode cable is on your right side, the work cable should also be on your right side.

2.d.4. Connect the work cable to the workpiece as close as possible to the area being welded.

2.d.5. Do not work next to welding power source.



ELECTRIC SHOCK can kill.

3.a. The electrode and work (or ground) circuits are electrically “hot” when the welder is on. Do not touch these “hot” parts with your bare skin or wet clothing. Wear dry, hole-free gloves to insulate hands.

3.b. Insulate yourself from work and ground using dry insulation. Make certain the insulation is large enough to cover your full area of physical contact with work and ground.

In addition to the normal safety precautions, if welding must be performed under electrically hazardous conditions (in damp locations or while wearing wet clothing; on metal structures such as floors, gratings or scaffolds; when in cramped positions such as sitting, kneeling or lying, if there is a high risk of unavoidable or accidental contact with the workpiece or ground) use the following equipment:

- Semiautomatic DC Constant Voltage (Wire) Welder.
- DC Manual (Stick) Welder.
- AC Welder with Reduced Voltage Control.

3.c. In semiautomatic or automatic wire welding, the electrode, electrode reel, welding head, nozzle or semiautomatic welding gun are also electrically “hot”.

3.d. Always be sure the work cable makes a good electrical connection with the metal being welded. The connection should be as close as possible to the area being welded.

3.e. Ground the work or metal to be welded to a good electrical (earth) ground.

3.f. Maintain the electrode holder, work clamp, welding cable and welding machine in good, safe operating condition. Replace damaged insulation.

3.g. Never dip the electrode in water for cooling.

3.h. Never simultaneously touch electrically “hot” parts of electrode holders connected to two welders because voltage between the two can be the total of the open circuit voltage of both welders.

3.i. When working above floor level, use a safety belt to protect yourself from a fall should you get a shock.

3.j. Also see Items 6.c. and 8.



ARC RAYS can burn.

4.a. Use a shield with the proper filter and cover plates to protect your eyes from sparks and the rays of the arc when welding or observing open arc welding. Headshield and filter lens should conform to ANSI Z87.1 standards.

4.b. Use suitable clothing made from durable flame-resistant material to protect your skin and that of your helpers from the arc rays.

4.c. Protect other nearby personnel with suitable, non-flammable screening and/or warn them not to watch the arc nor expose themselves to the arc rays or to hot spatter or metal.



FUMES AND GASES can be dangerous.

5.a. Welding may produce fumes and gases hazardous to health. Avoid breathing these fumes and gases. When welding, keep your head out of the fume. Use enough ventilation and/or exhaust at the arc to keep fumes and gases away from the breathing zone. **When welding with electrodes which require special ventilation such as stainless or hard facing (see instructions on container or MSDS) or on lead or cadmium plated steel and other metals or coatings which produce highly toxic fumes, keep exposure as low as possible and within applicable OSHA PEL and ACGIH TLV limits using local exhaust or mechanical ventilation. In confined spaces or in some circumstances, outdoors, a respirator may be required. Additional precautions are also required when welding on galvanized steel.**

5.b. The operation of welding fume control equipment is affected by various factors including proper use and positioning of the equipment, maintenance of the equipment and the specific welding procedure and application involved. Worker exposure level should be checked upon installation and periodically thereafter to be certain it is within applicable OSHA PEL and ACGIH TLV limits.

5.c. Do not weld in locations near chlorinated hydrocarbon vapors coming from degreasing, cleaning or spraying operations. The heat and rays of the arc can react with solvent vapors to form phosgene, a highly toxic gas, and other irritating products.

5.d. Shielding gases used for arc welding can displace air and cause injury or death. Always use enough ventilation, especially in confined areas, to insure breathing air is safe.

5.e. Read and understand the manufacturer’s instructions for this equipment and the consumables to be used, including the material safety data sheet (MSDS) and follow your employer’s safety practices. MSDS forms are available from your welding distributor or from the manufacturer.

5.f. Also see item 1.b.

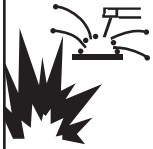

WELDING and CUTTING SPARKS can cause fire or explosion.

- 6.a. Remove fire hazards from the welding area. If this is not possible, cover them to prevent the welding sparks from starting a fire. Remember that welding sparks and hot materials from welding can easily go through small cracks and openings to adjacent areas. Avoid welding near hydraulic lines. Have a fire extinguisher readily available.
- 6.b. Where compressed gases are to be used at the job site, special precautions should be used to prevent hazardous situations. Refer to "Safety in Welding and Cutting" (ANSI Standard Z49.1) and the operating information for the equipment being used.
- 6.c. When not welding, make certain no part of the electrode circuit is touching the work or ground. Accidental contact can cause overheating and create a fire hazard.
- 6.d. Do not heat, cut or weld tanks, drums or containers until the proper steps have been taken to insure that such procedures will not cause flammable or toxic vapors from substances inside. They can cause an explosion even though they have been "cleaned". For information, purchase "Recommended Safe Practices for the Preparation for Welding and Cutting of Containers and Piping That Have Held Hazardous Substances", AWS F4.1 from the American Welding Society (see address above).
- 6.e. Vent hollow castings or containers before heating, cutting or welding. They may explode.
- 6.f. Sparks and spatter are thrown from the welding arc. Wear oil free protective garments such as leather gloves, heavy shirt, cuffless trousers, high shoes and a cap over your hair. Wear ear plugs when welding out of position or in confined places. Always wear safety glasses with side shields when in a welding area.
- 6.g. Connect the work cable to the work as close to the welding area as practical. Work cables connected to the building framework or other locations away from the welding area increase the possibility of the welding current passing through lifting chains, crane cables or other alternate circuits. This can create fire hazards or overheat lifting chains or cables until they fail.
- 6.h. Also see item 1.c.
- 6.i. Read and follow NFPA 51B "Standard for Fire Prevention During Welding, Cutting and Other Hot Work", available from NFPA, 1 Batterymarch Park, PO box 9101, Quincy, Ma 022690-9101.
- 6.j. Do not use a welding power source for pipe thawing.



CYLINDER may explode if damaged.

- 7.a. Use only compressed gas cylinders containing the correct shielding gas for the process used and properly operating regulators designed for the gas and pressure used. All hoses, fittings, etc. should be suitable for the application and maintained in good condition.
- 7.b. Always keep cylinders in an upright position securely chained to an undercarriage or fixed support.
- 7.c. Cylinders should be located:
 - Away from areas where they may be struck or subjected to physical damage.
 - A safe distance from arc welding or cutting operations and any other source of heat, sparks, or flame.
- 7.d. Never allow the electrode, electrode holder or any other electrically "hot" parts to touch a cylinder.
- 7.e. Keep your head and face away from the cylinder valve outlet when opening the cylinder valve.
- 7.f. Valve protection caps should always be in place and hand tight except when the cylinder is in use or connected for use.
- 7.g. Read and follow the instructions on compressed gas cylinders, associated equipment, and CGA publication P-1, "Precautions for Safe Handling of Compressed Gases in Cylinders," available from the Compressed Gas Association 1235 Jefferson Davis Highway, Arlington, VA 22202.



FOR ELECTRICALLY powered equipment.

- 8.a. Turn off input power using the disconnect switch at the fuse box before working on the equipment.
- 8.b. Install equipment in accordance with the U.S. National Electrical Code, all local codes and the manufacturer's recommendations.
- 8.c. Ground the equipment in accordance with the U.S. National Electrical Code and the manufacturer's recommendations.

Refer to <http://www.lincolnelectric.com/safety> for additional safety information.

PRÉCAUTIONS DE SÛRETÉ

Pour votre propre protection lire et observer toutes les instructions et les précautions de sûreté spécifiques qui paraissent dans ce manuel aussi bien que les précautions de sûreté générales suivantes:

Sûreté Pour Soudage A L'Arc

1. Protégez-vous contre la secousse électrique:
 - a. Les circuits à l'électrode et à la pièce sont sous tension quand la machine à souder est en marche. Eviter toujours tout contact entre les parties sous tension et la peau nue ou les vêtements mouillés. Porter des gants secs et sans trous pour isoler les mains.
 - b. Faire très attention de bien s'isoler de la masse quand on soude dans des endroits humides, ou sur un plancher métallique ou des grilles métalliques, principalement dans les positions assis ou couché pour lesquelles une grande partie du corps peut être en contact avec la masse.
 - c. Maintenir le porte-électrode, la pince de masse, le câble de soudage et la machine à souder en bon et sûr état de fonctionnement.
 - d. Ne jamais plonger le porte-électrode dans l'eau pour le refroidir.
 - e. Ne jamais toucher simultanément les parties sous tension des porte-électrodes connectés à deux machines à souder parce que la tension entre les deux pinces peut être le total de la tension à vide des deux machines.
 - f. Si on utilise la machine à souder comme une source de courant pour soudage semi-automatique, ces précautions pour le porte-électrode s'appliquent aussi au pistolet de soudage.
2. Dans le cas de travail au dessus du niveau du sol, se protéger contre les chutes dans le cas où on reçoit un choc. Ne jamais enrouler le câble-électrode autour de n'importe quelle partie du corps.
3. Un coup d'arc peut être plus sévère qu'un coup de soleil, donc:
 - a. Utiliser un bon masque avec un verre filtrant approprié ainsi qu'un verre blanc afin de se protéger les yeux du rayonnement de l'arc et des projections quand on soude ou quand on regarde l'arc.
 - b. Porter des vêtements convenables afin de protéger la peau de soudeur et des aides contre le rayonnement de l'arc.
 - c. Protéger l'autre personnel travaillant à proximité au soudage à l'aide d'écrans appropriés et non-inflammables.
4. Des gouttes de laitier en fusion sont émises de l'arc de soudage. Se protéger avec des vêtements de protection libres de l'huile, tels que les gants en cuir, chemise épaisse, pantalons sans revers, et chaussures montantes.
5. Toujours porter des lunettes de sécurité dans la zone de soudage. Utiliser des lunettes avec écrans latéraux dans les

zones où l'on pique le laitier.

6. Eloigner les matériaux inflammables ou les recouvrir afin de prévenir tout risque d'incendie dû aux étincelles.
7. Quand on ne soude pas, poser la pince à un endroit isolé de la masse. Un court-circuit accidentel peut provoquer un échauffement et un risque d'incendie.
8. S'assurer que la masse est connectée le plus près possible de la zone de travail qu'il est pratique de le faire. Si on place la masse sur la charpente de la construction ou d'autres endroits éloignés de la zone de travail, on augmente le risque de voir passer le courant de soudage par les chaînes de levage, câbles de grue, ou autres circuits. Cela peut provoquer des risques d'incendie ou d'échauffement des chaînes et des câbles jusqu'à ce qu'ils se rompent.
9. Assurer une ventilation suffisante dans la zone de soudage. Ceci est particulièrement important pour le soudage de tôles galvanisées plombées, ou cadmiées ou tout autre métal qui produit des fumées toxiques.
10. Ne pas souder en présence de vapeurs de chlore provenant d'opérations de dégraissage, nettoyage ou pistolage. La chaleur ou les rayons de l'arc peuvent réagir avec les vapeurs du solvant pour produire du phosgène (gas fortement toxique) ou autres produits irritants.
11. Pour obtenir de plus amples renseignements sur la sûreté, voir le code "Code for safety in welding and cutting" CSA Standard W 117.2-1974.

PRÉCAUTIONS DE SÛRETÉ POUR LES MACHINES À SOUDER À TRANSFORMATEUR ET À REDRESSEUR

1. Relier à la terre le châssis du poste conformément au code de l'électricité et aux recommandations du fabricant. Le dispositif de montage ou la pièce à souder doit être branché à une bonne mise à la terre.
2. Autant que possible, l'installation et l'entretien du poste seront effectués par un électricien qualifié.
3. Avant de faire des travaux à l'intérieur de poste, la débrancher à l'interrupteur à la boîte de fusibles.
4. Garder tous les couvercles et dispositifs de sûreté à leur place.

Electromagnetic Compatibility (EMC)

Conformance

Products displaying the CE mark are in conformity with European Community Council Directive of 15 Dec 2004 on the approximation of the laws of the Member States relating to electromagnetic compatibility, 2004/108/EC. It was manufactured in conformity with a national standard that implements a harmonized standard: EN 60974-10 Electromagnetic Compatibility (EMC) Product Standard for Arc Welding Equipment. It is for use with other Lincoln Electric equipment. It is designed for industrial and professional use.

Introduction

All electrical equipment generates small amounts of electromagnetic emission. Electrical emission may be transmitted through power lines or radiated through space, similar to a radio transmitter. When emissions are received by other equipment, electrical interference may result. Electrical emissions may affect many kinds of electrical equipment; other nearby welding equipment, radio and TV reception, numerical controlled machines, telephone systems, computers, etc. Be aware that interference may result and extra precautions may be required when a welding power source is used in a domestic establishment.

Installation and Use

The user is responsible for installing and using the welding equipment according to the manufacturer's instructions. If electromagnetic disturbances are detected then it shall be the responsibility of the user of the welding equipment to resolve the situation with the technical assistance of the manufacturer. In some cases this remedial action may be as simple as earthing (grounding) the welding circuit, see Note. In other cases it could involve construction of an electromagnetic screen enclosing the power source and the work complete with associated input filters. In all cases electromagnetic disturbances must be reduced to the point where they are no longer troublesome.

Note: The welding circuit may or may not be earthed for safety reasons according to national codes. Changing the earthing arrangements should only be authorized by a person who is competent to access whether the changes will increase the risk of injury, e.g., by allowing parallel welding current return paths which may damage the earth circuits of other equipment.

Assessment of Area

Before installing welding equipment the user shall make an assessment of potential electromagnetic problems in the surrounding area. The following shall be taken into account:

- a) other supply cables, control cables, signaling and telephone cables; above, below and adjacent to the welding equipment;
- b) radio and television transmitters and receivers;
- c) computer and other control equipment;
- d) safety critical equipment, e.g., guarding of industrial equipment;
- e) the health of the people around, e.g., the use of pacemakers and hearing aids;
- f) equipment used for calibration or measurement
- g) the immunity of other equipment in the environment. The user shall ensure that other equipment being used in the environment is compatible. This may require additional protection measures;
- h) the time of day that welding or other activities are to be carried out.

Electromagnetic Compatibility (EMC)

The size of the surrounding area to be considered will depend on the structure of the building and other activities that are taking place. The surrounding area may extend beyond the boundaries of the premises.

Methods of Reducing Emissions

Mains Supply

Welding equipment should be connected to the mains supply according to the manufacturer's recommendations. If interference occurs, it may be necessary to take additional precautions such as filtering of the mains supply. Consideration should be given to shielding the supply cable of permanently installed welding equipment, in metallic conduit or equivalent. Shielding should be electrically continuous throughout its length. The shielding should be connected to the welding power source so that good electrical contact is maintained between the conduit and the welding power source enclosure.

Maintenance of the Welding Equipment

The welding equipment should be routinely maintained according to the manufacturer's recommendations. All access and service doors and covers should be closed and properly fastened when the welding equipment is in operation. The welding equipment should not be modified in any way except for those changes and adjustments covered in the manufacturer's instructions. In particular, the spark gaps of arc striking and stabilizing devices should be adjusted and maintained according to the manufacturer's recommendations.

Welding Cables

The welding cables should be kept as short as possible and should be positioned close together, running at or close to floor level.

Equipotential Bonding

Bonding of all metallic components in the welding installation and adjacent to it should be considered. However, metallic components bonded to the work piece will increase the risk that the operator could receive a shock by touching these metallic components and the electrode at the same time. The operator should be insulated from all such bonded metallic components.

Earthing of the Workpiece

Where the workpiece is not bonded to earth for electrical safety, not connected to earth because of its size and position, e.g., ships hull or building steelwork, a connection bonding the workpiece to earth may reduce emissions in some, but not all instances. Care should be taken to prevent the earthing of the workpiece increasing the risk of injury to users, or damage to other electrical equipment. Where necessary, the connection of the workpiece to earth should be made by a direct connection to the workpiece, but in some countries where direct connection is not permitted, the bonding should be achieved by suitable capacitance, selected according to national regulations.

Screening and Shielding

Selective screening and shielding of other cables and equipment in the surrounding area may alleviate problems of interference. Screening of the entire welding installation may be considered for special applications.

1

¹ Portions of the preceding text are contained in EN 60974-10: "Electromagnetic Compatibility (EMC) product standard for arc welding equipment."

MASTER TABLE OF CONTENTS FOR ALL SECTIONS

	Page
Safety	i-iv
Installation	Section A
Operation	Section B
Accessories	Section C
Maintenance	Section D
Theory of Operation	Section E
Troubleshooting and Repair	Section F
How to Use Troubleshooting Guide.....	F-2
Troubleshooting Guide	F-4
Test Procedures	F-14
Replacement Procedures	F-36
Electrical Diagrams	Section G
Parts Manual	P409 & P202-C Series

TABLE OF CONTENTS - INSTALLATION SECTION -

INSTALLATION	Section A
Technical Specifications.....	A-2
Safety Precautions	A-3
Input Supply Connection Diagram.....	A-4
Gun and Cable Installation	A-5

Return to Master TOC

Return to Master TOC

Return to Master TOC

Return to Master TOC

TECHNICAL SPECIFICATIONS – POWER MIG® 300

INPUT – SINGLE PHASE ONLY

Standard Voltage/Frequency 208/230/460/575/60 Hz	Input Current @ 230Amp Rated Output 48/43/22/17 Amps	Input Current @ 300 Amp Rated Output 72/62/31/25 Amps
--	--	---

RATED OUTPUT

Input Voltage	Duty Cycle	Amps	Volts at Rated Amperes
208	40%	300 Amps	32 Volts
230/460/575	60%	300 Amps	32 Volts
208/230/460/575	100%	230Amps	29 Volts

OUTPUT

Welding Current Range (Continuous) 5 – 350 Amps	Maximum Open Circuit Voltage 67 Volts	Welding Voltage Range 10-45 Volts
---	---	---

RECOMMENDED INPUT WIRE AND FUSE SIZES - SINGLE PHASE

Input Voltage/ Frequency (Hz)	230Amps @	300Amps @	75°C Copper Wire	Fuse
	29 Volts (100% Duty Cycle)	32 Volts (60% Duty Cycle)	AWG (IEC) Sizes (MM²)	or Breaker Size
208/60*	48 A	72 A	6 (16 mm ²)	90 A
230/60	43 A	62 A	6 (16 mm ²)	80 A
460/60	22 A	31 A	10 (6 mm ²)	50 A
575/60	17 A	25 A	12 (2.5 mm ²)	35 A

NOTE: Use #10 AWG Grounding Wire

*For 208V Input ONLY: The duty Cycle Rating at 300 Amps is 40%

PHYSICAL DIMENSIONS

Height	Width	Depth	Weight
31.79 in 808 mm	18.88 in 480 mm	38.78 in 985 mm	255 lbs 116 kg

WIRE SPEED RANGE

Wire Speed	50 – 700 IPM (1.27 – 17.8 m/minute)
-------------------	-------------------------------------

POWER MIG® 300



Return to Section TOC

Return to Master TOC

Return to Section TOC

Return to Master TOC

Return to Section TOC

Return to Master TOC

Return to Section TOC

Return to Master TOC

Read entire installation section before starting installation.

SAFETY PRECAUTIONS

WARNING



ELECTRIC SHOCK can kill.

- Do not touch electrically live parts or electrode with skin or wet clothing.
- Insulate yourself from work and ground.
- Always wear dry insulating gloves.
- Do not use AC welder if your clothing, clothes or work area is damp or if working on, under or inside work piece.

Use the following equipment:

- Semiautomatic DC constant voltage (wire) welder.
- DC manual (stick) welder.
- AC welder with reduced voltage control.
- Do not operate with panels removed.
- Disconnect input power before servicing.



FUMES AND GASES can be dangerous.

- Keep your head out of fumes.
- Use ventilation or exhaust to remove fumes from breathing zone and general area.



WELDING SPARKS can cause fire or explosion.

- Keep flammable material away.
- Do not weld on closed containers.



ARC RAYS can burn eyes and skin.

- Wear eye, ear and body protection.

Observe all safety information throughout this manual.

ONLY QUALIFIED PERSONNEL SHOULD INSTALL, USE OR SERVICE THIS EQUIPMENT.

UNCRATING THE POWER MIG® 300

Cut banding and lift off cardboard carton. Cut banding holding the machine to the skid. Remove foam and corrugated packing material. Untape accessories from Gas Bottle Platform. Unscrew the two wood screws (at the Gas Bottle Platform) holding the machine to the skid. Roll the machine off the skid assembly.

LOCATION

Locate the welder in a dry location where there is free circulation of clean air into the louvers in the back and out the front. A location that minimizes the amount of smoke and dirt drawn into the rear louvers reduces the chance of dirt accumulation that can block air passages and cause overheating.

INPUT POWER, GROUNDING AND CONNECTION DIAGRAMS

1. Before starting the installation, check with the local power company if there is any question about whether your power supply is adequate for the voltage, amperes, phase, and frequency specified on the welder nameplate. Also be sure the planned installation will meet the U.S. National Electrical Code and local code requirements. This welder may be operated from a single phase line or from one phase of a two or three phase line.
2. The POWER MIG® 300 is supplied connected for 230 Volt Input. If the welder is to be operated on another voltage, it must be reconnected according to the instructions in Figure A.1

FIGURE A.1 — Triple Voltage Machine Input Connections

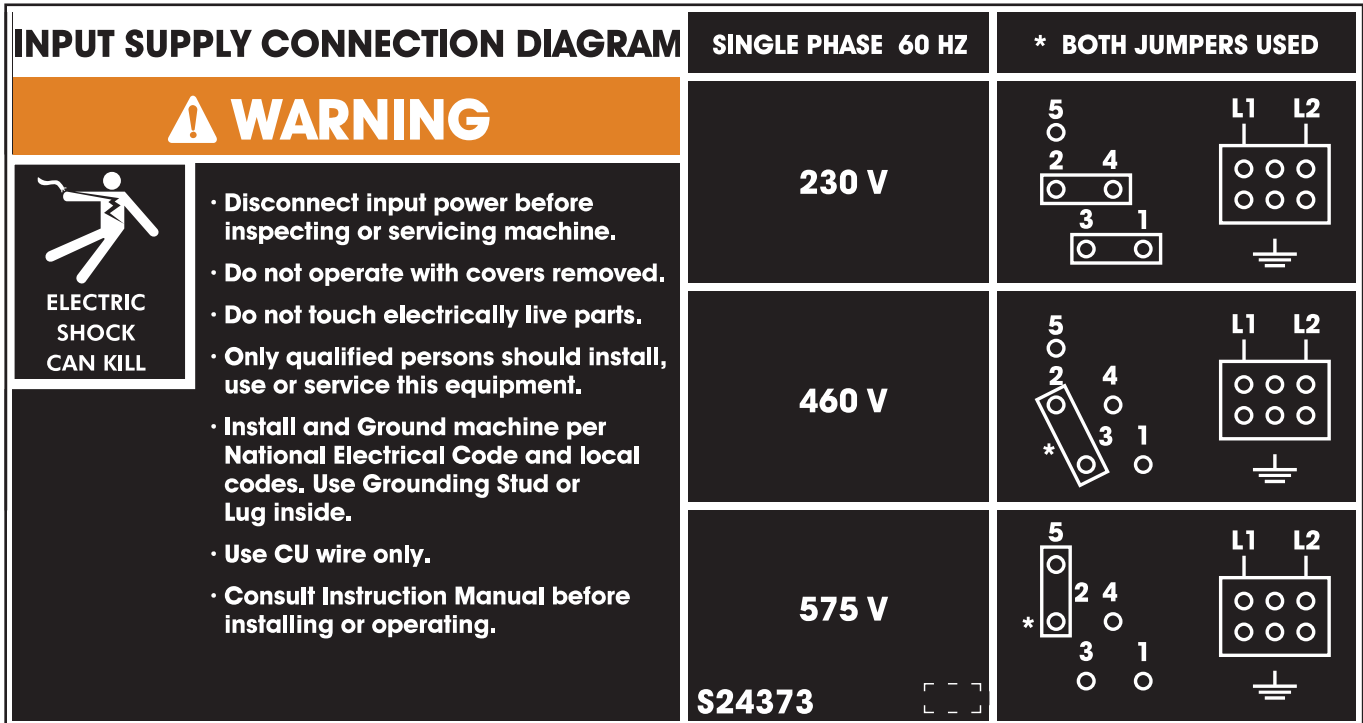

3. The POWER MIG is shipped with a 10ft.(3.05m) input cable and plug connected to the welder. Using the instructions in Figure A.2, have a qualified electrician connect the receptacle or cable to the input power lines and the system ground per the U.S. National Electrical Code and any applicable local codes. See “Technical Specifications” at the beginning of this chapter for proper wire sizes. For long runs over 100ft. (30.48m), larger copper wires should be used. Fuse the two hot lines with super lag type fuses as shown in the following diagram. The center contact in the receptacle is for the grounding connection. A green wire in the input cable connects this contact to the frame of the welder. This ensures proper grounding of the welder frame when the welder plug is inserted into the receptacle.

FIGURE A.2 — Receptacle Diagram

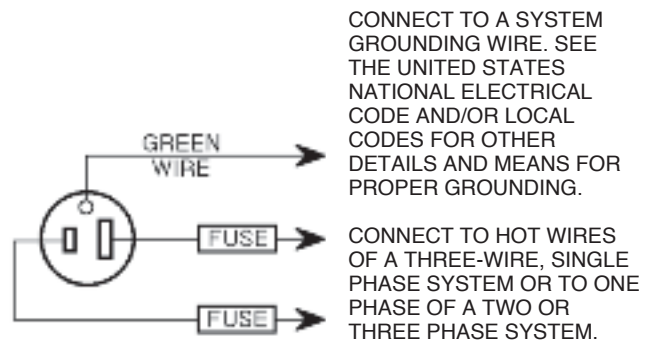

Return to Section TOC

Return to Master TOC

GUN AND CABLE INSTALLATION

A Magnum 300 gun and 15Ft.(4.6m) cable (12Ft.(3.7m) for Codes 11000 and below) are provided with the POWER MIG® 300. A Magnum cable liner for .035-.045" (0.9-1.2 mm) electrode and contact tips for .035" (0.9mm) and .045" (1.2mm) are included for 15Ft..

WARNING

Turn the welder power switch off before installing gun and cable.

LINER INSTALLATION AND TRIMMING INSTRUCTION (SEE FIGURE A.3)

1. Remove the gas nozzle.
2. Remove the gas diffuser from the gun tube. If gas diffuser contains a small set screw, loosen the set screw.
3. Lay gun and cable out straight on a flat surface. Loosen set screw of the connector on the back end of the gun.
4. Insert the untrimmed Liner into the back end of the gun.
5. Seat Liner bushing into back of gun. Secure Liner by tightening set screw. Do not install the gas diffuser at this time.
6. Lay the cable straight and trim Liner to 9/16". Remove burrs.
7. Secure the gas diffuser into the tube.
8. Tighten the set screw against the Liner.

CAUTION

This screw should only be gently tightened. Over tightening will split or collapse the liner and cause poor wire feeding.

GUN & CABLE ASSEMBLY INSTALLED INTO THE POWER MIG

1. Unscrew knurled screw on the drive unit front end (inside wire feed compartment) until tip of screw no longer protrudes into gun opening as seen from front of machine.
2. Insert the male end of gun cable into the female casting through opening in front panel. Make sure connector is fully inserted and tighten knurled screw.
3. Connect the gun trigger connector from the gun and cable to the mating receptacle inside the compartment located above the gun connection made in step 2 above. Make sure that the key ways are aligned, insert and tighten retaining ring.

SHIELDING GAS

(For Gas Metal Arc Welding Processes)

Customer must provide cylinder of appropriate type shielding gas for the process being used.

A gas flow regulator, for CO₂ or Argon blend gas, and an inlet gas hose are factory provided with the POWER MIG® 300.

WARNING



CYLINDER may explode if damaged.

- Gas under pressure is explosive. Always keep gas cylinders in an upright position and always keep chained to undercarriage or stationary support. See American National Standard Z-49.1, "Safety in Welding and Cutting" published by the American Welding Society.

Install shielding gas supply as follows:

1. Set gas cylinder on rear platform of POWER MIG® 300. Hook chain in place to secure cylinder to rear of welder.
2. Remove the cylinder cap. Inspect the cylinder valves and regulator for damaged threads, dirt, dust, oil or grease. Remove dust and dirt with a clean cloth.

FIGURE A.3

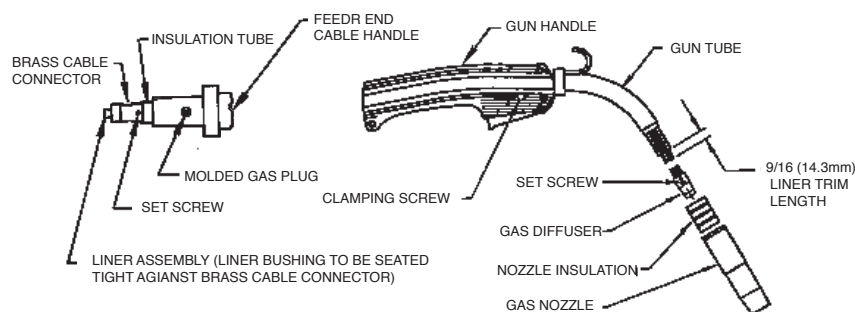

POWER MIG® 300



DO NOT ATTACH THE REGULATOR IF OIL, GREASE OR DAMAGE IS PRESENT! Inform your gas supplier of this condition. Oil or grease in the presence of high pressure oxygen is explosive.

3. Stand to one side away from the outlet and open the cylinder valve for an instant. This blows away any dust or dirt which may have accumulated in the valve outlet.

⚠ WARNING

Be sure to keep your face away from the valve outlet when “cracking” the valve.

4. Attach the flow regulator to the cylinder valve and tighten the union nut(s) securely with a wrench.

NOTE: If connecting to 100% CO₂ cylinder, insert regulator adapter between regulator and cylinder valve. If adapter is equipped with a plastic washer, be sure it is seated for connection to the CO₂ cylinder.

5. Attach one end of the inlet gas hose to the outlet fitting of the flow regulator, the other end to the POWER MIG® 300 rear fitting, and tighten the union nuts securely with a wrench.
6. Before opening the cylinder valve, turn the regulator adjusting knob counterclockwise until the adjusting spring pressure is released.
7. Standing to one side, open the cylinder valve slowly a fraction of a turn. When the cylinder pressure gauge pointer stops moving, open the valve fully.

⚠ WARNING

Never stand directly in front of or behind the flow regulator when opening the cylinder valve. Always stand to one side.

8. The flow regulator is adjustable. Adjust it to the flow rate recommended for the procedure and process being used before making the weld.

TABLE OF CONTENTS - OPERATION SECTION -

Operation	Section B
Definitions of Welding Modes.....	B-2
Product Description.....	B-3
Controls and Settings.....	B-3/B-4
Setting and Configuring.....	B-5
Multi-Process Panel Functions.....	B-6
Arc Control.....	B-7
Wire Drive Roll.....	B-8
Changing Drive and Idle Roll Sets.....	B-9
Feeding Wire Electrode.....	B-10
Pulse Welding.....	B-11
Pulse-On-Pulse.....	B-12
Power Mode.....	B-13

Return to Master TOC

Return to Master TOC

Return to Master TOC

Return to Master TOC

Read entire Operation section before operating the POWER MIG® 300.

⚠ WARNING



ELECTRIC SHOCK can kill.

- Do not touch electrically live parts or electrode with skin or wet clothing. Insulate yourself from work and ground.
- Always wear dry insulating gloves.



FUMES AND GASES can be dangerous.

- Keep your head out of fumes.
- Use ventilation or exhaust to remove fumes from breathing zone.



WELDING SPARKS can cause fire or explosion.

- Keep flammable material away.
- Do not weld on closed containers.



ARC RAYS can burn eyes and skin.

- Wear eye, ear and body protection.

Observe all safety information throughout this manual.

DEFINITIONS OF WELDING MODES

NON-SYNERGIC WELDING MODES

- A **Non-synergic** welding mode requires all welding process variables to be set by the operator.

SYNERGIC WELDING MODES

- A **Synergic** welding mode offers the simplicity of single knob control. The machine will select the correct voltage and amperage based on the wire feed speed (WFS) set by the operator.

COMMON WELDING ABBREVIATIONS

WFS

- Wire Feed Speed

CC

- Constant Current

CV

- Constant Voltage

GMAW (MIG)

- Gas Metal Arc welding

GMAW-P (MIG)

- Gas Metal Arc welding-(Pulse)

GMAW-PP (MIG)

- Gas Metal Arc welding-(Pulse-on-Pulse)

GTAW (TIG)

- Gas Tungsten Arc welding

SMAW (STICK)

- Shielded Metal Arc welding

FCAW (INNERSHIELD)

- Flux Core Arc Welding

PRODUCT DESCRIPTION

The POWER MIG® 300 is a complete semiautomatic multi-process DC arc welding machine offering CV and CC DC welding. It is rated for 300 amps, 32 volts at a 60% duty cycle. The standard machine is equipped to weld CC-Stick, CC-GTAW, CV-FCAW, and synergic and non-synergic CV-GMAW / GMAW-P and Pulse-on-Pulse and Power Mode welding processes. See the descriptions for Pulse™ and Power Mode welding processes later in this section.

Mode #5 and mode #6 are non-synergic CV GMAW modes for bare and flux cored wires, respectively. In these modes, the user presets the wire feed speed (WFS) on the left meter and the welding voltage on the right. These two settings are independent; that is, if the WFS is changed the voltage will remain constant, or vice versa.

All of the other mode numbers designated as "CV" are synergic. Again, WFS is shown on the left meter and voltage is shown on the right meter. However, in using these modes, the WFS is preset and the voltage is preset only once. Now, when the WFS is changed, the voltage will change with it, so that the arc appearance and arc length will stay the same without the necessity to re-adjust the voltage.

The modes shown as "GMAW-P" or "GMAW-PP" are all synergic pulsed modes. In these modes WFS is shown on the left meter and "Trim" is shown on the right meter. The user adjusts WFS to obtain an arc with the correct arc energy for the material thickness being welded. The Trim, which is adjustable from values of -1.5 to 0 (OFF) and up to +1.5 controls the arc length. Higher values of Trim give longer arc lengths. Once the user has adjusted the Trim for one WFS, the power supply will synergically change many variables so that, as the WFS is changed, the arc length and arc appearance will remain the same. The synergic modes are usable with both push and pull torches, as described later in this Manual. When using a spool gun, however, although the synergic pulsed modes are still accessible, they must be used in a non-synergic manner as described in the Accessory Section.

The digital microcomputer based control system allows easy and accurate adjustment of weld parameters through the multi-process panel located on the front of the machine. The POWER MIG® 300 is equipped with a 6-pin and 7-pin connector to allow operation of a push-pull gun for feeding aluminum wires, a spool gun, remotes, and a foot amprotol.

Other features

Optional kits are available for push-pull welding, spool gun operation, push feeding of 3/64 aluminum with the standard POWER MIG® 300 gun and wire feeder. A Dual Cylinder Mounting Kit is also offered.

CONTROLS AND SETTINGS

(See Figure B.1)

1. WIRE FEED SPEED (WFS) / AMP METER - This meter displays either the WFS or current value (Amps) depending on the status of the machine. Located below the display is the text "WFS" and "Amps." An LED light is illuminated to the left of one of these units to indicate the units of the value displayed on the meter.

- Prior to CV operation, the meter displays the desired preset WFS value.
- Prior to CC-Stick and CC-GTAW operation, the meter displays the preset current value.
- During Welding, the meter displays actual average amps.
- After welding, the meter holds the actual current value for 5 seconds. During this time, the display is blinking to indicate that the machine is in the "Hold" period. Output adjustment while in the "Hold" period results in the "prior to operation" characteristics stated above.
- After the 5 second "Hold" period, the meter displays the set WFS (CV modes) or Amp (CC modes) value.

Figure B.1

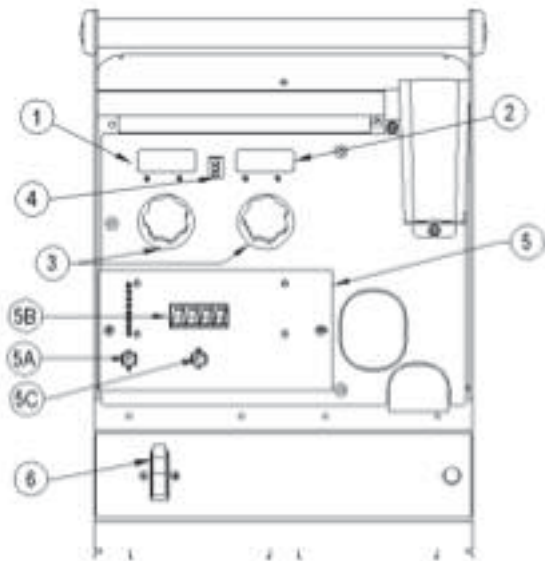

POWER MIG® 300

LINCOLN
ELECTRIC

2. VOLT / TRIM METER - This meter displays either the voltage or trim value depending on the status of the machine. Located below the display is the text "Volts" and "Trim." An LED light is illuminated to the left of one of these in order to indicate the units of the value displayed in the meter.

CV Processes

- Prior to GMAW and FCAW operation, the meter displays the desired preset Voltage value.
- Prior to synergic GMAW-P and GMAW-PP operation, the meter displays the desired preset Trim value. Trim adjusts the synergic default voltage as a percentage of that voltage. A trim value of 1 is the default and results in the recommended voltage setting for a given wire feed speed. Adjusting trim to a value of .95, adjusts the voltage to 95% of the recommended voltage.
- During Welding, the meter displays actual average volts.
- After welding, the meter holds the actual voltage value for 5 seconds. During this time, the display is blinking to indicate that the machine is in the "Hold" period. Output adjustment while in the "Hold" period results in the "prior to operation" characteristics stated above.
- After the 5 second "Hold" period, the meter displays the set Voltage (GMAW, FCAW) or Trim (GMAW-P) value.

CC Processes

- The meter displays the status of the output.
- When output is enabled, the meter will display "ON."
- When there is no output, the meter will display "OFF."

3. OUTPUT CONTROLS - The POWER MIG® 300 has 2 encoder knobs to adjust weld parameters.

- Each encoder changes the displayed value of the meter located directly above that encoder.
- In CC-GTAW modes, the left encoder sets the maximum welding current. Full depression of a foot or hand amptrol results in the preset level of current.
- In CC-Stick and CC-GTAW, the right encoder activates and de-activates the output. Turning the encoder clockwise enables the output if not using a remote trigger device. To de-energize the output, turn the encoder counter-clockwise. The display above will indicate the "ON" or "OFF" status of the output.

4. THERMAL - This status light illuminates when the power source has been driven into thermal overload.

5. MULTI-PROCESS PANEL - This panel enables selection of weld modes as well as adjustment of certain weld parameters within each weld mode.

The eight discrete LED's are used to identify which selection will be shown on the display. The possible selections are:

- Weld Mode (Process selection choices)
 - Preflow / Postflow
 - Run-In
 - Start
 - Arc Control
 - Crater
 - Burnback
 - Spot
- } Choice of weld parameters that can be adjusted. Complete descriptions of each parameter are found later in this section.

Only one LED will be illuminated at any time. The Weld Mode attribute will always be a valid selection (the other attributes may not be available in all processes).

5A. SELECT Toggle Switch

- This switch toggles through the 8 selections detailed above the switch.
- A red LED is located next to each possible selection and is illuminated when that choice can be changed.

5B. Display Meter

- This meter displays the active weld mode (a set of weld parameters that have been determined to provide the recommended results for a particular welding process) when the "Weld Mode" LED is illuminated or when any one of the other seven LED's is illuminated the meter indicates what value that welding parameter has been set to.

5C. SET Toggle Switch

- This switch adjusts (up or down) the value shown on the display meter. When the WELD MODE LED is illuminated, this switch is changing the weld mode of the machine. The most commonly used modes are displayed in the chart on the right half of the Multi-Process Panel.

If the LED next to a weld parameter (Preflow/Postflow, Run-In, Start, etc.) is illuminated, the SET switch will adjust the setting of that specific weld parameter. The setting is shown on the display meter.

6. ON/OFF POWER SWITCH

SETTING AND CONFIGURING THE POWER MIG® 300 FOR WELDING

- Check that the electrode polarity is correct for the process and turn the Power Switch to the "ON" position. After the "boot-up" period (approximately 20 seconds), the POWER MIG® 300 will default to the last preset weld mode that was active when the machine was powered down. The Multi-Process Panel defaults with the "Weld Mode" active.
- Toggle the SET switch to the desired "Weld Mode" operation. The Multi-Process Meter displays a weld mode number corresponding to a CC or CV welding process as detailed by the chart on the right side of the panel. In the example shown in Figure B.2 "3" is displayed above the SET switch. This means that the machine is set for CC-GTAW (TIG) welding.
- Toggle the SELECT switch to activate the "weld parameters" for the selected weld mode.
- Set each parameter using the SET switch to adjust the parameter displayed on the display meter.

NOTE: If the LED next to the weld parameter is flashing, the WFS/AMP and/or the Volt/Trim values can also be adjusted for that parameter using the control knobs below each display meter. An LED below each of the displays will also be flashing to indicate which value is adjustable.

The Table B.1 shows which weld parameters are adjustable for a given weld mode. The weld parameters are detailed later in this section.

FIGURE B.2



TABLE B.1

	PREFLOW / POSTFLOW	RUN IN	START	ARC CONTROL	CRATER	BURNBACK	SPOT
CC-STICK	-----	-----	Yes	Yes	-----	-----	-----
CC-GTAW	Yes	-----	Yes	-----	-----	-----	-----
CV-FCAW	-----	Yes	Yes	Yes	Yes	Yes	Yes
CV-GMAW	Yes	Yes	Yes	Yes	Yes	Yes	Yes
CV-GMAW-P	Yes	Yes	Yes	Yes	Yes	Yes	Yes
POWER	Yes	Yes	Yes	Yes	Yes	Yes	Yes

POWER MIG® 300



Return to Section TOC

Return to Section TOC

Return to Section TOC

Return to Master TOC

Return to Master TOC

Return to Master TOC

MULTI-PROCESS PANEL FUNCTIONS

Weld Mode

Setting the Weld Mode is selecting the proper program from the ones available in the machine's memory for a particular welding application. The table on the right side of the front panel (See **Figure B.2**) gives information on the different programs available in this machine. It describes the type of process (CV, CC, synergic GMAW), type of metal (mild steel, stainless steel, aluminum), type of shielding gas and size of electrode recommended for a particular mode.

The Weld Mode selection is enabled by toggling the SELECT switch until the LED next to Weld Mode is lit. A Weld Mode number will be displayed on the display meter. Toggling the SET switch up or down will increase or decrease the WELD MODE number displayed. The machine will change to the selected weld mode after two seconds of SET switch inactivity. If the SELECT switch is changed before two seconds of SET switch inactivity, the machine will not change modes. The last active Weld Mode will be saved at power down so that it will be selected with the next power up of the machine.

Preflow / Postflow

- The Preflow setting allows a time to be selected for shielding gas to flow after the trigger is pulled and prior to wire feeding and establishing an arc.
- The Postflow setting allows a time to be selected for shielding gas to continue to flow after the trigger is released and output current is turned off.
- The Preflow timer will be selected by toggling the SELECT switch until the LED next to PREFLOW /POSTFLOW is lit. The display meter will read Pre. The present Preflow time will be displayed and can be changed by positioning the SET switch up or down.
- The Postflow timer will be selected by pressing down the SELECT switch an additional time. The LED next to PREFLOW / POSTFLOW will remain lit; but the display meter will now read Pos. The present Postflow time will be displayed and can be changed by positioning the SET switch up or down.
- The default value for both Preflow and Postflow is "OFF" (0 seconds).
- Preflow can be adjusted from 0 to 2.5 seconds in 0.1 second increments.
- Postflow can be adjusted from 0 to 10.0 seconds in 0.1 second increments.

Run-In

- The Run-In function offers the ability to set a wire feed speed, from trigger until an arc is established, that is independent of the Welding or Start wire feed speed. Setting a Run-In WFS lower than the welding WFS avoids stubbing problems when starting the arc.
- Run-In is selected by toggling the SELECT switch until the LED next to RUN-IN is lit. A Run-In WFS may be adjusted using the SET switch on the Multi-Process Panel. The Display meter on the Multi-Process Panel will indicate the run-in speed. Do not use the Output Control Knob on the upper case front to adjust the WFS. This will change the welding WFS displayed in the meters on the upper case front.
- The default value for Run-In is "OFF."
- Run-In speed is adjustable from 50 ipm to 150 ipm (Inches per Minute).

Start Procedure

This machine provides the option of setting a Starting Procedure to start the weld, and from there, to ramp to the welding procedure over a specified amount of time. Typically starting on a higher starting procedure than the welding procedure is known as a "Hot Start". Setting a starting procedure lower than the welding procedure is known as a "Cold Start".

For **SMAW (Stick) welding** setting a "Hot Start" helps to minimize stubbing the electrode.

For **GTAW (TIG) welding** setting a "Cold Start" minimizes burn-through of thin materials when not using a manual amperage control.

For **Wire Feed welding** using a start procedure can help improve starting characteristics. A good example is when welding aluminum. Aluminum's high thermal conductivity results in heat spreading around the plate very fast. Therefore more energy is necessary at the very beginning to heat up the starting point of the weld. Once the welding begins, it is not necessary to give this extra heat anymore so a ramp down to the welding procedure is necessary.

To set a Start Procedure begin by using the SELECT switch to select the Start LED. Using the SET switch, enter the desired Start ramp time duration (its available values range from 0.01 seconds to 0.50 seconds in increments of 0.01 seconds or the default value of OFF). This value will be displayed on the digital meter of the multiprocess panel (See **Figure B.2**).

After setting the Start time also set the WFS, and voltage/trim. The way to know what information needs to be entered is to look for flashing LED's. If an LED is flashing that parameter value needs to be entered.

In the case of special waveforms designed for pulsed welding aluminum, Pulse on Pulse™, the effect is similar to what occurs with standard pulse. As the Arc Control is increased from +1 to +10 the frequency of the Pulse on Pulse array increases. As the frequency increases the weld bead ripples become less distinct and the arc cone narrows. When the Arc Control is set from -1 to -10 the Pulse on Pulse arrays decrease in frequency, the weld bead ripples become more distinct, and the bead width increases.

In **GMAW-PP mode**, arc control adjusts the modulation frequency, which means the speed at which the ripples are produced in the weld. (See **Pulse-on-pulse** description later in this section.) When faster travel speeds are desired, arc control needs to be set higher. When slower travel speeds are desired, arc control needs to be set lower.

- The Arc-control adjustment is selected by toggling the SELECT switch until the LED next to ARC CONTROL is lit. The Arc-control value will be displayed. Arc-control can be adjusted by toggling the SET switch up or down.
- The default value is "OFF."

Crater

The crater is the end of the weld, which normally solidifies creating a concave surface. This can result in stresses that can cause cracks in the center of the crater. The purpose of the Crater control is to fill up the crater, so that its surface becomes flat.

Crater control in this machine is more efficient than in other machines. Normally, in other machines, the crater filling procedure is a step down from the welding WFS to the crater filling WFS. In this machine instead of a step down, the transition is a ramp down, which results in a more controlled filling up of the crater and so, less stresses present in it.

The values to enter are first the desired time to stay at the Crater settings and the desired WFS and voltage/trim to fill the crater.

- The Crater timer is selected by toggling the SELECT switch until the LED next to CRATER is lit and flashing. A crater time may be set using the SET switch.
- The available values for crater control time go from "Off" to 0.1 seconds and from there to 10.0 seconds in increments of 0.1 seconds.
- The Crater function offers the ability to set an endpoint for WFS and Voltage that will be reached over a specified time period. At the end of the weld when the trigger is released, the crater timer will begin and the WFS and Volts settings will ramp down from the Weld Mode WFS and Voltage settings to the Crater WFS and Voltage settings over the time selected. This creates a ramp down of the WFS and Volts during the Crater time.

- In the GMAW, FCAW, and Power weld modes, crater WFS and voltage are adjustable using the control knobs on the upper case front. This is indicated by the flashing LED's next to "WFS" and "VOLTS."
- In the GMAW-P weld modes, Crater WFS and trim are adjustable. This is indicated by the flashing LEDs next to "WFS" and "TRIM."

Burnback

Setting the Burnback means setting the adjustable time delay between turning off the wire feeding and turning off the arc. Burnback helps to prevent wire sticking to the puddle.

- The Burnback feature will allow current to continue to flow for a specified time period at the end of a weld after wire feeding has stopped.
- The Burnback timer will be selected by toggling the SELECT switch until the LED next to BURNBACK is lit. A burnback time may be set using the SET switch.
- The default value is "OFF" (0 seconds).
- Burnback time is adjustable from 0 to 0.25 seconds in 0.01 second increments.

Spot

The Spot Timer adjusts arc on-time for spot or tack welds.

- With the Spot feature active (Spot time selected), when the trigger is pulled and the arc is established, the weld will continue until the expiration of the spot timer and the next active state will be enabled (crater or burnback). The trigger must be released and pulled again for another Spot cycle.
- The Spot timer is selected by toggling the SELECT switch until the LED next to SPOT is lit. The present SPOT time will be displayed and can be changed by toggling the SET switch up or down.
- The default value is "OFF" (0 seconds).
- Spot can be adjusted from 0 to 10.0 seconds in 0.1 second increments.

WIRE DRIVE ROLL

The drive rolls installed with the POWER MIG® 300 have two grooves, one side for .030" (0.8mm) solid steel electrode, and the other for the .045"(1.2mm) electrode. The actual drive roll size is stenciled on the side opposite of its groove. If feeding problems occur, a check may be required to make sure that the wire size and the drive roll size matches. See **Procedure for Changing Drive Rolls** in this section.

PROCEDURE FOR CHANGING DRIVE AND IDLE ROLL SETS

1. Turn off the power source.
2. Release the pressure on the idle roll by swinging the adjustable pressure arm down toward the back of the machine. Lift the cast idle roll assembly and allow it to sit in an upright position.
3. Remove the outside wire guide retaining plate by loosening the two large knurled screws.
4. Twist the drive roll retaining mechanism to the unlocked position as shown below and remove the drive roll. (See Figure B.3)

FIGURE B.3

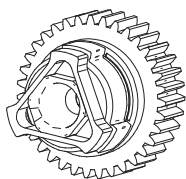

UNLOCKED POSITION

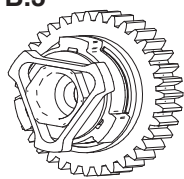

LOCKED POSITION

5. Remove the inside wire guide plate.
6. Replace the drive and idle rolls and inside wire guide with a set marked for the new wire size. **NOTE:** Be sure that the gun liner and contact tip are also sized to match the selected wire size.
7. Manually feed the wire from the wire reel, over the drive roll groove and through the wire guide and then into the brass bushing of the gun and cable assembly.
8. Replace the outside wire guide retaining plate by tightening the two large knurled screws. Reposition the adjustable pressure arm to its original position to apply pressure. Adjust pressure as necessary.

WIRE REEL LOADING - READI-REELS, SPOOLS OR COILS

To Mount a 30 Lb. (14 kg) Read-Reel Package (Using the Molded Plastic K363-P Read-Reel Adapter):

1. Open the Wire Drive Compartment Door
2. Depress the Release Bar on the Retaining Collar and remove it from the spindle.
3. Place the Optional Adapter on the spindle
4. Re-install the Retaining Collar. Make sure that the Release Bar "pops up" and that the collar retainers fully engage the retaining ring groove on the spindle.

5. Rotate the spindle and adapter so the retaining spring is at the 12 o'clock position.
6. Position the Read-Reel so that it will rotate in a direction when feeding so as to be de-reeled from top the of the coil.
7. Set one of the Read-Reel inside cage wires on the slot in the retaining spring tab.
8. Lower the Read-Reel to depress the retaining spring and align the other inside cage wires with the grooves in the molded adapter.
9. Slide cage all the way onto the adapter until the retaining spring "pops up" fully.

CAUTION

Check to be sure the retaining ring has fully returned to the locking position and has securely locked the Read-Reel cage in place. Retaining spring must rest on the cage, not the welding electrode.

10. To remove Read-Reel from Adapter, depress retaining spring tab with thumb while pulling the Read-Reel cage from the molded adapter with both hands. Do not remove adapter from spindle.

FIGURE B.4

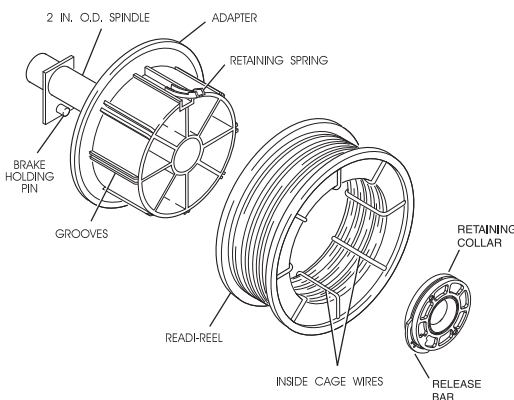

TO MOUNT 10 to 44 Lb. (4.5-20 kg) SPOOLS (12"/300 mm Diameter) or 14Lb.(6 Kg) Innershield Coils:

(For 13-14 lb. (6 Kg) Innershield coils, a K435 Coil Adapter must be used).

1. Open the Wire Drive Compartment Door
2. Depress the Release Bar on the Retaining Collar and remove it from the spindle.
3. Place the spool on the spindle making certain the spindle brake pin enters one of the holes in the back side of the spool (Note: an arrow mark on the spindle lines up with the brake holding pin to assist in lining up a hole). Be certain the wire comes off the reel in a direction so as to de-reel from the top of the coil.

4. Re-install the Retaining Collar. Make sure that the Release Bar “pops up” and that the collar retainers fully engage the retaining ring groove on the spindle.

FEEDING WIRE ELECTRODE

WARNING

When triggered, the electrode and drive mechanism are electrically “hot” relative to work and ground and remain “hot” several seconds after the gun trigger is released.

NOTE: Check that drive rolls, guide plates and gun parts are proper for the wire size and type being used. Refer to *Table C.1* in *ACCESSORIES* section.

1. Turn the Readi-Reel or spool until the free end of the electrode is accessible.
2. While securely holding the electrode, cut off the bent end and straighten the first six inches. (If the electrode is not properly straightened, it may not feed properly through the wire drive system).
3. Release the pressure on the idle roll by swinging the adjustable pressure arm down toward the back of the machine. Lift the cast idle roll assembly and allow it to sit in an upright position. Leave the outer wire guide plate installed. Manually feed the wire through the incoming guide bushing and through the guide plates (over the drive roll groove). Push a sufficient wire length to assure that the wire has fed into the gun and cable assembly without restriction. Reposition the adjustable pressure arm to its original position to apply pressure to the wire.
4. Press gun trigger to feed the electrode wire through the gun.

IDLE ROLL PRESSURE SETTING

The idle roll pressure adjustment knob is set at the factory at the #2 hash mark. This is an approximate setting. The optimum idle roll pressure varies with type of wire, wire diameter, surface conditions, lubrication, and hardness. As a general rule, hard wires may require greater pressure, and soft, or aluminum wire, may require less pressure than the factory setting. The optimum idle roll setting can be determined as follows:

1. Press end of gun against a solid object that is electrically isolated from the welder output and press the gun trigger for several seconds.
2. If the wire “birdnests”, jams or breaks at the drive roll, the idle roll pressure is too great. Back the adjustment knob out 1/2 turn, run new wire through gun, and repeat above steps.
3. If the only result was drive roll slippage, loosen the adjustment knob on the conductor plate and pull the gun cable forward about 6" (15 cm). There should be a slight waviness in the expose wire. If there is not waviness, the pressure is too low. Tighten the adjustment knob 1/4 turn, reinstall the gun cable and repeat the above steps.

AVOIDING WIRE FEEDING PROBLEMS

Wire feeding problems can be avoided by observing the following gun handling procedures:

- a. Do not kink or pull cable around sharp corners.
- b. Keep the gun cable as straight as possible when welding or loading electrode through cable.
- c. Do not allow dolly wheels or trucks to run over cables.
- d. Keep cable clean by following maintenance instructions.
- e. Use only clean, rust-free electrode. Lincoln electrodes have proper surface lubrication.
- f. Replace the contact tip when the arc starts to become unstable or the contact tip end is fused or deformed.
- g. Keep wire reel spindle brake tension to the minimum required to prevent excess reel over-travel which may cause wire “loop-offs” from the coil.
- h. Use proper drive rolls and wire drive/idle roll pressure for wire size and type being used.

PULSE-ON-PULSE™ (GMAW-PP)

Pulse on Pulse™ is a Lincoln process specifically designed for use in welding relatively thin (less than 1/4" thick) aluminum (See Table B.3). It gives weld beads with very consistent uniform ripple.

In Pulse on Pulse modes, two distinct pulse types are used, instead of the single pulse type normally used in GMAW-P. A number of high energy pulses are used to obtain spray transfer and transfer metal across the arc. Such pulses are shown in Figure B.6. After a number "N" of such pulses, depending on the wire feed speed used, an identical number "N" of low energy pulses are performed. These low energy pulses, shown in Figure B.6, do not transfer any filler metal across the arc and help to cool the arc and keep the heat input low.

FIGURE B.6

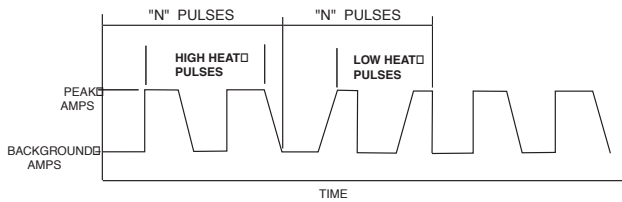

The Peak Current, Background Current, and Frequency are identical for the high energy and low energy pulses. In addition to cooling the weld down, the major effect of the low energy pulses is that they form a weld ripple. Since they occur at very regular time intervals, the weld bead obtained is very uniform with a very consistent ripple pattern. In fact, the bead has its best appearance if no oscillation of the welding gun ("whipping") is used. (See Figure B.7)

FIGURE B.7

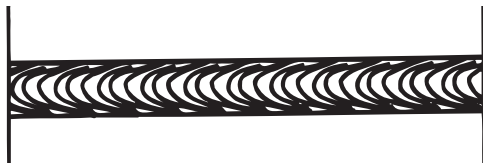

When Arc Control is used in the Pulse on Pulse modes, it does the same things it does in the other pulsed modes: decreasing the Arc Control decreases the droplet transfer and weld deposition rate. Increasing the Arc Control increases the droplet transfer and weld deposition rate. Since Arc Control varies weld droplet transfer rate, the Arc Control can be used to vary the ripple spacing in the weld bead.

BENEFITS OF PULSE ON PULSE FROM LINCOLN ELECTRIC

- Excellent appearance of the weld bead
- Improved cleaning action
- Reduced porosity

Table B.3 shows WFS and Trim settings for common aluminum types and wire sizes when welding with Pulse-on-Pulse. The welds made to obtain the values in the table were fillet welds in the flat position. The values in the table can be helpful as a starting point to establish a welding procedure. From there, adjustments need to be made to set the proper procedure for each specific application (out-of-position, other types of joints, etc.).

The comments on Table B.3 show values of WFS below which it is not recommended to weld. The reason is, that below these values the weld transfer will change from a spray arc to a short-arc, which is not advisable when welding aluminum.

WELDING PROCEDURES FOR PULSE-ON-PULSE (TABLE B.3)

MATERIAL	Aluminum 4043	Aluminum 4043	Aluminum 5356	Aluminum 5356
GAS	100% Ar.	100% Ar.	100% Ar.	100% Ar.
WIRE	E4043	E4043	E5356	E5356
WIRE SIZE	0.035	3/64	0.035	3/64
WELD MODE	98	99	101	102
MATERIAL THICKNESS WFS / TRIM	14 ga.	250 / 1.0	200 / 1.0	230 / 1.0
	10 ga.	400 / 1.0	280 / 1.0	425 / 1.0
	3/16	550 / 1.0	340 / 1.0	670 / 1.0
	1/4	600 / 1.0	400 / 1.0	700 / 1.0
COMMENTS	Not Recommended below 200 WFS	Not Recommended below 100 WFS	Not Recommended below 200 WFS	Not Recommended below 200 WFS

[Return to Section TOC](#) | [Return to Master TOC](#)

Return to Section TOC Return to Section TOC Return to Section TOC
Return to Master TOC Return to Master TOC Return to Master TOC

POWER MIG® 300



TABLE OF CONTENTS - ACCESSORIES -

Accessories	Section C
Drive Roll Kits.....	C-2
Push-Pull Feeding Connection Adapter Kit.....	C-3

Return to Master TOC

Return to Master TOC

Return to Master TOC

Return to Master TOC

DRIVE ROLL KITS

Refer to Table C.1 for various drive roll kits that are available for the POWER MIG. All items in **Bold** are supplied standard with the POWER MIG.

TABLE C.1

Wire	Size	Drive Roll Kit
Solid Steel	.023"-.030" (0.6-0.8 mm)	KP1696-030S
	.035" (0.9 mm)	KP1696-035S
	.045" (1.2 mm)	KP1696-045S
	.040" (1.0mm)	KP-1696-2
	.035-.045" (0.9-0.2mm)	KP-1696-1
Cored	.035" (0.9 mm)	KP1697-035C
	.045" (1.2 mm)	KP1697-045C
Aluminum	3/64" (1.2 mm)	KP1695-3/64A

*.035 Aluminum recommended for Push-Pull systems only.

3/64" (1.2 mm) ALUMINUM FEEDING KIT (K2153-1)

This kit helps push feeding aluminum through standard machine feeder and gun. It provides gun and wire drive conversion parts to weld with 3/64" (1.2 mm) aluminum wire. 5356 alloy aluminum wire is recommended for best push feeding performance.

Kit includes drive rolls and wire guide plate for the wire drive, liner and two contact tips for the gun, along with installation instructions.

K363P READI-REEL ADAPTER

The K363P Readi-Reel Adapter mounts to the 2" spindle. It is needed to mount the 22-30 lb. Readi-Reels.

DUAL CYLINDER MOUNTING KIT (K1702-1)

Permits stable side-by-side mounting of two full size (9" dia. x 5' high) gas cylinders with "no lift" loading. Simple installation and easy instructions provided. Includes upper and lower cylinder supports, wheel axles and mounting hardware.

ALTERNATIVE MAGNUM GMAW GUN AND CABLE ASSEMBLIES

The following Magnum 300 gun and cable assemblies are separately available for use with the POWER MIG® 300. Each is rated 300 amps 60% duty cycle (or 300 amps 40% duty) and is equipped with the integrated connector, twist-lock trigger connector, fixed nozzle and insulator, and includes a liner, diffuser, and contact tips for the wire sizes specified:

Length	Part No.	English Wire Size	Metric Wire Size
10' (3.0 m)	K470-1	.035 – .045"	0.9 – 1.2 mm
12' (3.6 m)	K470-7		
15' (4.5 m)	K470-3		

MAGNUM GUN CONNECTION KIT (Optional K466-6)

Using the optional K466-6 Magnum Connection kit for the POWER MIG permits use of standard Magnum 200, 300 or 400 gun and cable assemblies.

K1692-2 SPOOL GUN (PRINCE™ XL)

When the POWER MIG Gun Selector Switch is in the "Standard / Spool Gun" position, the POWER MIG provides gun trigger switch transfer between the Magnum gun or the spool gun for the same polarity welding with different wire and gas processes.

CAUTION

Closing either gun trigger will cause the electrode of both guns to be electrically "HOT". Be sure unused gun is positioned so electrode or tip will not contact metal case or other metal common to work.

Because the control circuitry senses each gun through its trigger leads, weld parameters are displayed and adjustable for the last gun that was triggered.

- Pulling the trigger for the built-in feeder gun (Magnum 300):**
 - Disables spool gun operation.
 - Changes the displays of the POWER MIG® 300 to correspond to feeder gun operation.
 - Closing feeder gun trigger starts feeder gun welding and makes both electrodes electrically "HOT".
- Pulling SPOOL GUN Trigger:**
 - Disables built-in feeder gun operation.
 - Changes the displays of the POWER MIG® 300 to correspond to Spool Gun operation.
 - Closing spool gun trigger starts spool gun welding and makes both electrodes electrically "HOT".
- Operation with POWER MIG® 300:**
 - Install the spool gun per the installation instructions
 - Turn the POWER MIG® 300 input power ON.
 - Make sure that the Gun Selector Switch is in the "Standard / Spool Gun" position.
 - Pull and release the trigger of the Spool Gun. The Power Mig recognizes the spool gun as active and weld parameters are adjustable for welding with the Spool Gun

Non-Synergic Weld Modes (Mode 5)

- Voltage is adjustable at the power source. The right control knob on the power source will adjust the voltage that is displayed in the meter directly above it.
- The left Display (WFS / AMPS) on the POWER MIG® 300 will have 4 dashes (----) to indicate that the left control knob on the power source is inactive. Wire Feed Speed is set at the Spool Gun.
- The following procedure settings for Aluminum 4043 can be used as initial settings for making test welds to determine final settings:

Wire Dia. In. (mm)	WFS Setting Spool Gun	Arc Voltage Setting
.030" (.8 mm)	270	15V
.035" (.9 mm)	250	16V
3/64" (1.2 mm)	240	20V

4. Synergic Weld Modes

The POWER MIG® 300 is designed to enable synergic weld modes and synergic pulse processes with the spool gun. The actual wire feed speed (WFS) of the spool gun must be measured and manually set on the POWER MIG® 300 as a work point for the POWER MIG® 300 (SPD).

- In synergic modes when the spool gun trigger is pulled, an adjustable value for the SPD work point is displayed in the left meter. The letters SPD are displayed in the right meter.
- The left control knob adjusts the SPD value. The right control knob is inactive.
- Measure the actual WFS, in inches per minute, at the spool gun and set the SPD at the POWER MIG® 300 to match this value. WFS can be measured by pulling the trigger of the spool gun and feeding wire for 6 seconds. Measure the length of wire (in inches) that was fed and multiply by 10.
- The POWER MIG® 300 is now configured and ready to weld in the synergic mode.
- Adjustment of the SPD value from the set value has the affect of adjusting trim or arc length.
- To increase the arc length; increase the SPD value at the POWER MIG® 300 to a value higher than the actual WFS.

Remember; do not change the WFS at the spool gun.

- To decrease the arc length; decrease the SPD value at the POWER MIG® 300 to a value lower than the actual WFS.

Remember: The dialed in SPD value at the POWER MIG® 300 does not control the WFS at the spool gun. Rather, it is adjusting the POWER MIG® 300 synergic work point. Therefore, adjusting the SPD value will not change your actual WFS at the spool gun. WFS can only be changed at the spool gun.

PUSH-PULL FEEDING CONNECTION ADAPTER KIT (K2154-1)

The push-pull adapter kit provides direct connection of a Cobra Gold or Prince XL torch to the POWER MIG® 300 wire feeder welder.

The kit is intended for use with the following Cobra Gold or Prince XL torches:

Cobra Gold			
Air Cooled 15'(5m)	K1589-1	Water-Cooled 15'(5m)	K1590-1
Air Cooled 25'(8m)	K1589-2	Water-Cooled 25'(8m)	K1590-2
Air Cooled 50'(15m)	K1589-3	Water-Cooled 50'(15m)	K1590-3
Prince XL			
Air Cooled 15'(5m)	K1591-1	Water-Cooled 15'(5m)	K1592-1
Air Cooled 25'(8m)	K1591-2	Water-Cooled 25'(8m)	K1592-2
Air Cooled 50'(15m)	K1591-3	Water-Cooled 50'(15m)	K1592-3

⚠ CAUTION

Remove all input power to the POWER MIG® 300 before installing the Connection Adapter Kit.

⚠ WARNING

Refer to the Owner's Manual of the Torch for Amperage and Duty Cycle rating information. The torch rating may not match the rating of the power source.

MAKING A WELD WITH THE PRINCE XL OR COBRA GOLD TORCH INSTALLED

- Set the idle roll pressure on the wire drive between an indicator reading of 0-2. A recommended start point is 1.5.
- Set the Gun Selection toggle switch located inside the wire drive compartment directly above the push-pull control cable connector to "PUSH-PULL GUN."
- Depending on the weld mode, set the Voltage or Trim at the POWER MIG® 300 using the right control knob located on the upper case front panel.
- The Wire Feed Speed (WFS) is set using the control knob on the Torch. The left control knob on the POWER MIG® 300 is inactive. The actual WFS being set at the torch is displayed on the POWER MIG® 300.
- All weld parameters normally available for the active weld mode are available during push-pull operation. Refer to the Operation Section of this manual.

POWER MIG® 300



Return to Section TOC Return to Section TOC Return to Section TOC Return to Section TOC
Return to Master TOC Return to Master TOC Return to Master TOC Return to Master TOC

POWER MIG® 300



TABLE OF CONTENTS -MAINTENANCE-

Maintenance	Section D
Safety Precautions & General Maintenance	D-2
Liner Removal and Replacement.....	D-3

Return to Master TOC

Return to Master TOC

Return to Master TOC

Return to Master TOC

SAFETY PRECAUTIONS

WARNING



ELECTRIC SHOCK can kill.

- Have an electrician install and service this equipment.
- Turn the input power off at the fuse box before working on equipment
- Do not touch electrically hot parts.

GENERAL MAINTENANCE

In extremely dusty locations, dirt may clog the air passages causing the welder to run hot. Blow dirt out of the welder with low-pressure air at regular intervals to eliminate excessive dirt and dust build-up on internal parts.

The fan motors have sealed ball bearings which require no service.

DRIVE ROLLS AND GUIDE PLATES

After every coil of wire, inspect the wire drive mechanism. Clean it as necessary by blowing with low pressure compressed air. Do not use solvents for cleaning the idle roll because it may wash the lubricant out of the bearing. All drive rolls are stamped with the wire sizes they will feed. If a wire size other than that stamped on the roll is used, the drive roll must be changed.

For instructions on replacing or changing drive roll, see **Wire Drive Rolls** in Operation section.

CONTACT TIP AND GAS NOZZLE INSTALLATION

- a. Choose the correct size contact tip for the electrode being used (wire size is stenciled on the side of the contact tip) and screw it snugly into the gas diffuser.
- b. Be sure the nozzle insulator is fully screwed onto the gun tube and does not block the gas holes in the diffuser. (**NOTE:** Insulator is not required when using the optional fixed gas nozzles.)
- c. Slip the appropriate gas nozzle onto the nozzle insulator. Adjustable gas nozzles are available with a .62" (15.9 mm) or .50" (12.7 mm) I.D., and in both standard (flush) and recessed design. The proper nozzle should be selected based on the welding application. Different length fixed nozzles are also available to fit 300 and 400 amp gun tubes to allow either spray or short-circuiting transfer welding.

Choose the gas nozzle as appropriate for the GMAW process to be used. Typically, the contact tip end should be flush to .12" (3.1 mm) extended for the short-circuiting transfer process and .12" (3.1 mm) recessed for spray transfer. For the Outershield (FCAW) process, 1/8" (3 mm) recess is recommended.

GUN TUBES AND NOZZLES

- a. Replace worn contact tips as required.
- b. Remove spatter from inside of gas nozzle and from tip after each 10 minutes of arc time or as required.

GUN CABLE CLEANING

To help prevent feeding problems, clean cable liner after using approximately 300 pounds (136 kg) of electrode. Remove the cable from the wire feeder and lay it out straight on the floor. Remove the contact tip from the gun. Using an air hose and only partial pressure, gently blow out the cable liner from the gas diffuser end.

⚠ CAUTION

Excessive pressure at the start may cause the dirt to form a plug.

Flex the cable over its entire length and again blow out the cable. Repeat this procedure until no further dirt comes out. If this has been done and feed problems are experienced, try liner replacement, and refer to trouble shooting section on rough wire feeding.

LINER REMOVAL AND REPLACEMENT (SEE FIGURE D.1)

LINER REMOVAL, INSTALLATION AND TRIMMING INSTRUCTIONS FOR MAGNUM 300

NOTE: The variation in cable lengths prevents the interchangeability of liners between guns. Once a liner has been cut for a particular gun, it should not be installed in another gun unless it can meet the liner cutoff length requirement. Liners are shipped with the jacket of the liner extended the proper amount.

1. Remove the gas nozzle.
2. Remove the gas diffuser from the gun tube. If gas diffuser contains a small set screw, loosen the set screw.
3. Lay gun and cable out straight on a flat surface. Loosen set screw of the connector on the back end of the gun.
4. Insert the untrimmed Liner into the back end of the gun.

5. Seat Liner bushing into back of gun. Secure Liner by tightening set screw. Do not install the gas diffuser at this time.
6. Lay the cable straight and trim Liner to 9/16". Remove burrs.
7. Secure the gas diffuser into the tube.
8. Tighten the set screw against the Liner.

⚠ CAUTION

This screw should only be gently tightened. Over tightening will split or collapse the liner and cause poor wire feeding.

FIGURE D.1

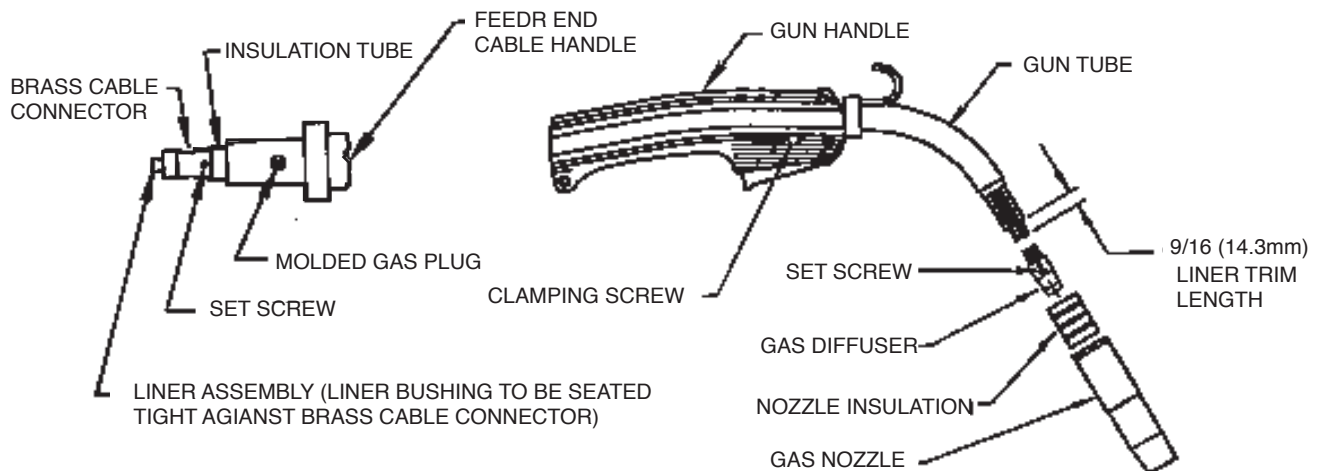

POWER MIG® 300

LINCOLN®
ELECTRIC

Return to Section TOC

Return to Section TOC

Return to Section TOC

Return to Section TOC

Return to Master TOC

Return to Master TOC

Return to Master TOC

Return to Master TOC

Return to Section TOC Return to Section TOC Return to Section TOC Return to Section TOC
Return to Master TOC Return to Master TOC Return to Master TOC Return to Master TOC

POWER MIG® 300

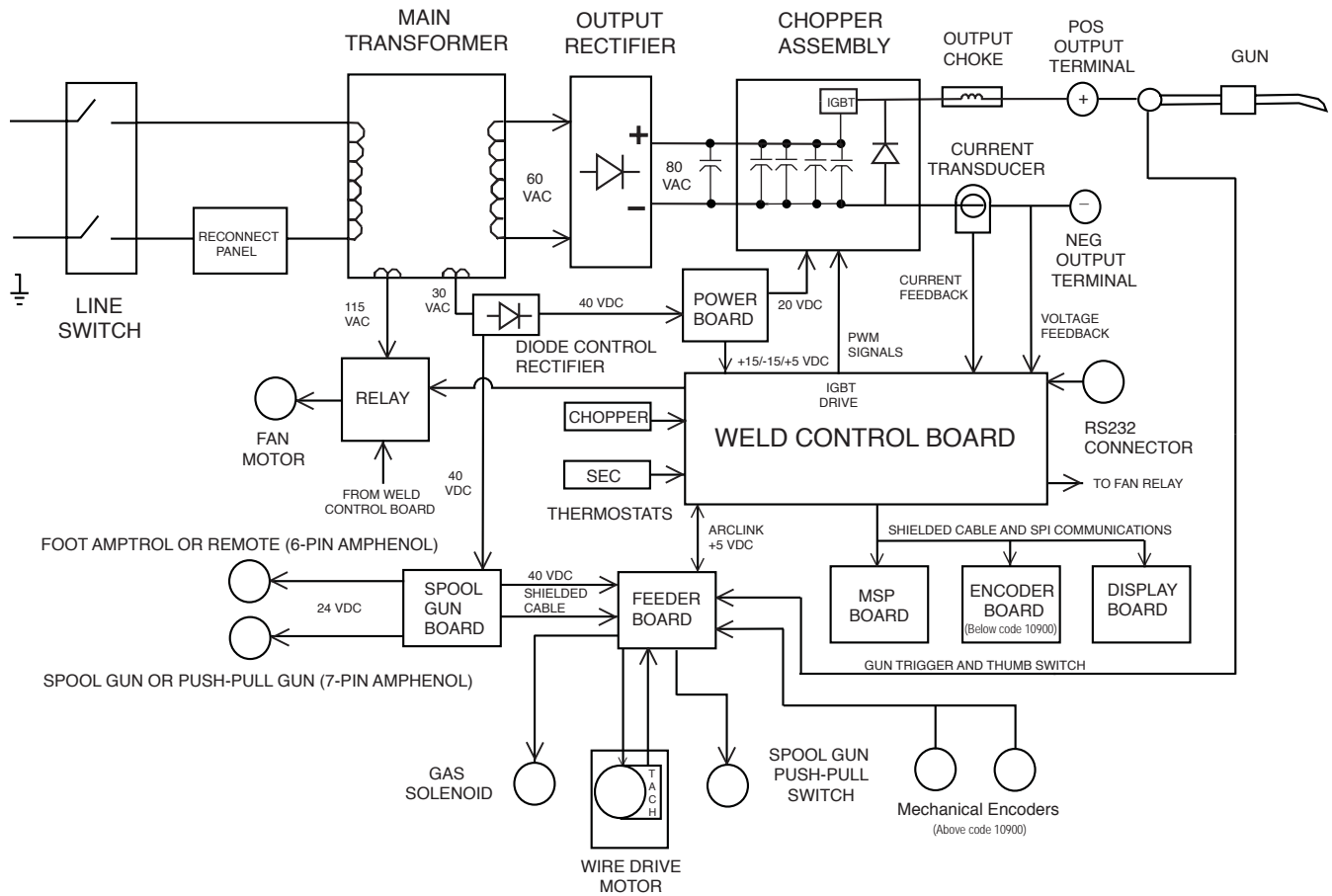

TABLE OF CONTENTS -THEORY OF OPERATION SECTION-

Theory of Operation.....Section E

General Description	E-2
Input Voltage and Main Transformer	E-3
Input Rectifier, Chopper Assembly And Feedback	E-4
Diode Control Rectifier and Power Board	E-5
Weld Control Board	E-6
Wire Drive Motor and Feedback.....	E-7
Thermal Protection, Over Current Protection, and Wire Feeder	
Overload Protection	E-8
Insulated Gate Bipolar Transistor (IGBT) Operation	E-9
Pulse Width Modulation.....	E-10
Chopper Technology Fundamentals	E-11

FIGURE E.1 – POWER MIG® 300 BLOCK LOGIC DIAGRAM



POWER MIG® 300



Return to Master TOC

Return to Master TOC

Return to Master TOC

Return to Master TOC

THEORY OF OPERATION

FIGURE E.2 – INPUT VOLTAGE AND MAIN TRANSFORMER

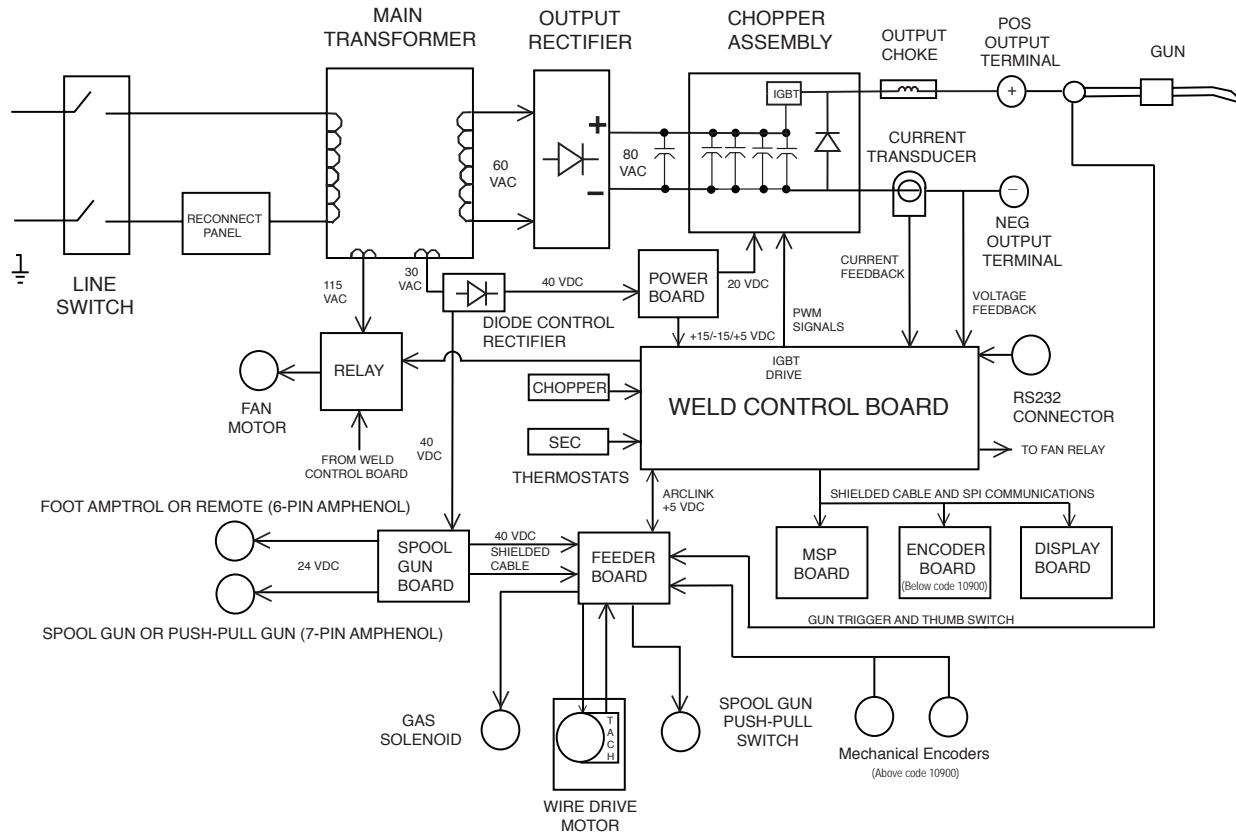

GENERAL DESCRIPTION

The POWER MIG® 300 is a complete semiautomatic, multi-process DC arc welding machine offering CV and CC DC welding. It is rated for 300 amps, 32 volts, at 60% duty cycle. The standard machine is equipped to weld CC Stick, CC-GTAW, CV-FCAW, and synergic and non-synergic CV GMAW/GMAW-P, Pulse-on-Pulse, and Power Mode welding processes.

The digital microcomputer based control system allows easy and accurate adjustment of weld parameters through the multi-process panel located on the front of the machine. The POWER MIG® 300 is equipped with a 6-pin connector for a foot amptrol or remotes and a 7-pin connector to allow operation of a spool gun or a push-pull gun for feeding aluminum wires.

NOTE: Unshaded areas of Block Logic Diagram are the subject of discussion.

POWER MIG® 300



THEORY OF OPERATION

FIGURE E.3 – INPUT RECTIFIER, CHOPPER ASSEMBLY AND FEEDBACK

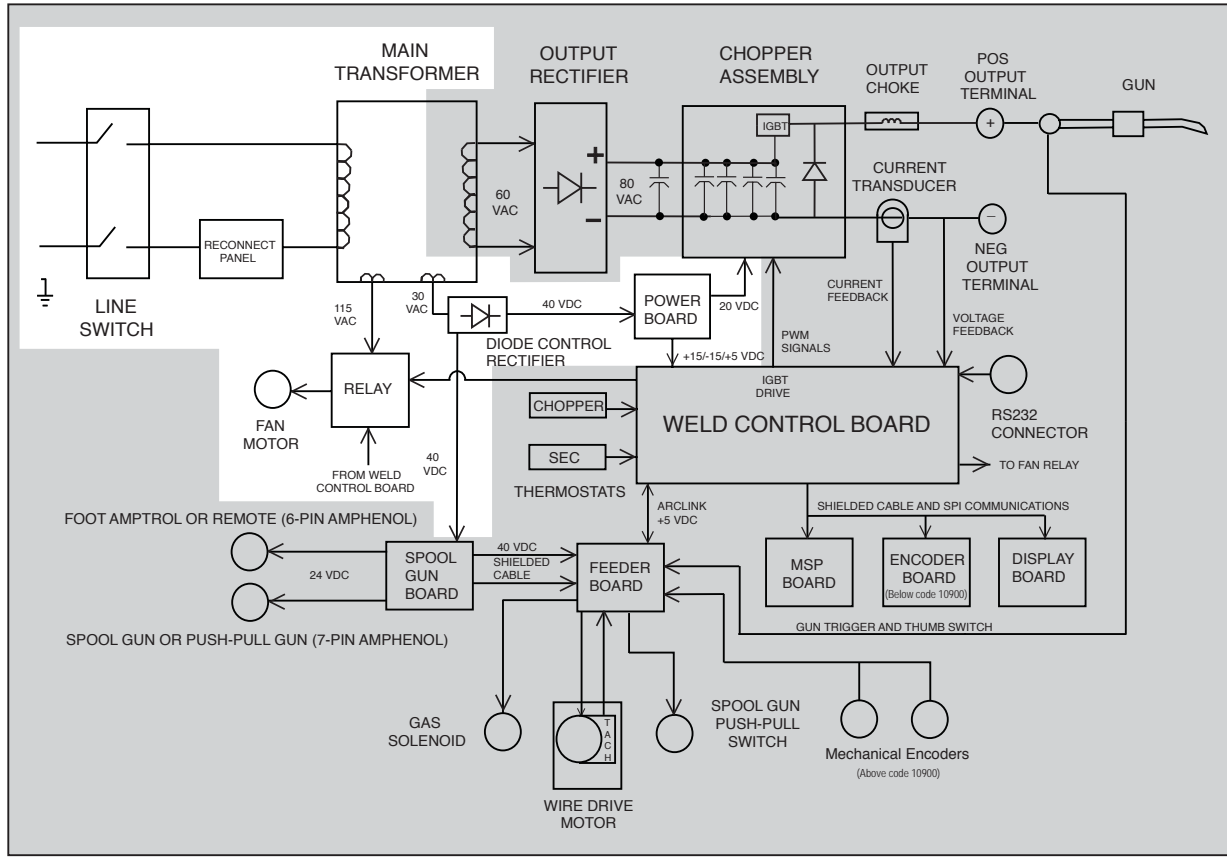

INPUT VOLTAGE AND MAIN TRANSFORMER 20

Single-phase input power is brought into the rear of the POWER MIG® 300 through a three-prong plug and input cable. A reconnect panel, also located on the rear of the machine, allows the user to configure the POWER MIG® 300 for either 230V, 460V, or 575V input supply power. An ON/OFF line switch is located on the front panel. When the line switch is ON, AC input voltage is applied to the primary winding of the main transformer. The main transformer converts the high voltage, low current input power to a low voltage, high current output. The main transformer also has two isolated auxiliary windings. One supplies 30 VAC to a Diode Control Rectifier, which converts the 30 VAC to 40 VDC to supply the Power Board and the Spool Gun Board. The Power Board in turn supplies

VDC to the Chopper Board and +15 VDC, -15 VDC and +5 VDC to the Weld Control Board circuitry. The other auxiliary winding provides 115 VAC to operate a thermostatically controlled fan motor through a relay, which also receives signals from the Weld Control Board. The fan is designed to come on automatically when the trigger is pulled. The fan will stay on as needed for a minimum of six minutes after the weld arc is terminated. The fan will also stay on when the machine's welding and feeding are disabled during thermostatic over-temperature protection. (**See Thermal and Overload Protection.**)

NOTE: Unshaded areas of Block Logic Diagram are the subject of discussion.

POWER MIG® 300



THEORY OF OPERATION

FIGURE E.4 – DIODE CONTROL RECTIFIER AND POWER BOARD

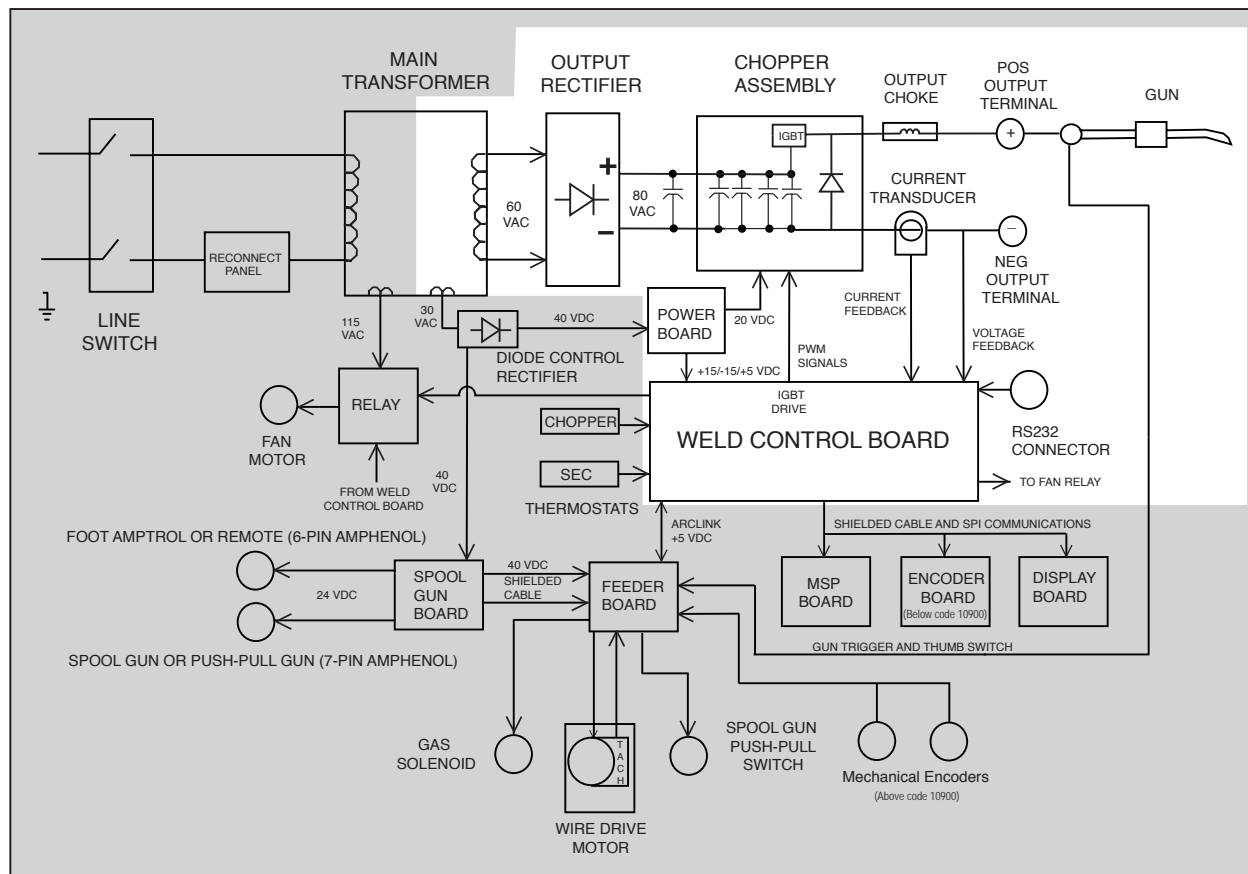

INPUT RECTIFIER, CHOPPER ASSEMBLY AND FEEDBACK

The 60 VAC output from the main transformer secondary is connected to an input rectifier. The resultant 80 VDC is applied to four parallel capacitors incorporated within the Chopper Assembly. These capacitors function as filters and also as power supplies for the insulated gate bipolar transistors or IGBT. See **IGBT Operation** in this section. The IGBT acts as a high-speed switch operating at 20KHZ. This device is switched on and off by the Weld Control Board through pulse width modulation circuitry. See **Pulse Width Modulation** in this section. This "chopped" DC output is applied through an output choke coil to the positive output terminal and through a current transducer to the negative output terminal. The choke functions as a current filter. A free-wheeling diode is incorporated in the Chopper Assembly to provide a current path for the stored energy in the choke when the IGBT is turned off. See **Chopper Technology Fundamentals** in this section.

Output voltage and current feedback information is fed to the Weld Control Board. This information is sensed from the current transducer and voltage sense circuitry on the output terminal circuits. If current or voltage become abnormally high, the Weld Control Board will shut off the IGBTs, thus disabling the machine's output.

NOTE: Unshaded areas of Block Logic Diagram are the subject of discussion.

POWER MIG® 300



THEORY OF OPERATION

FIGURE E.5 – WELD CONTROL BOARD

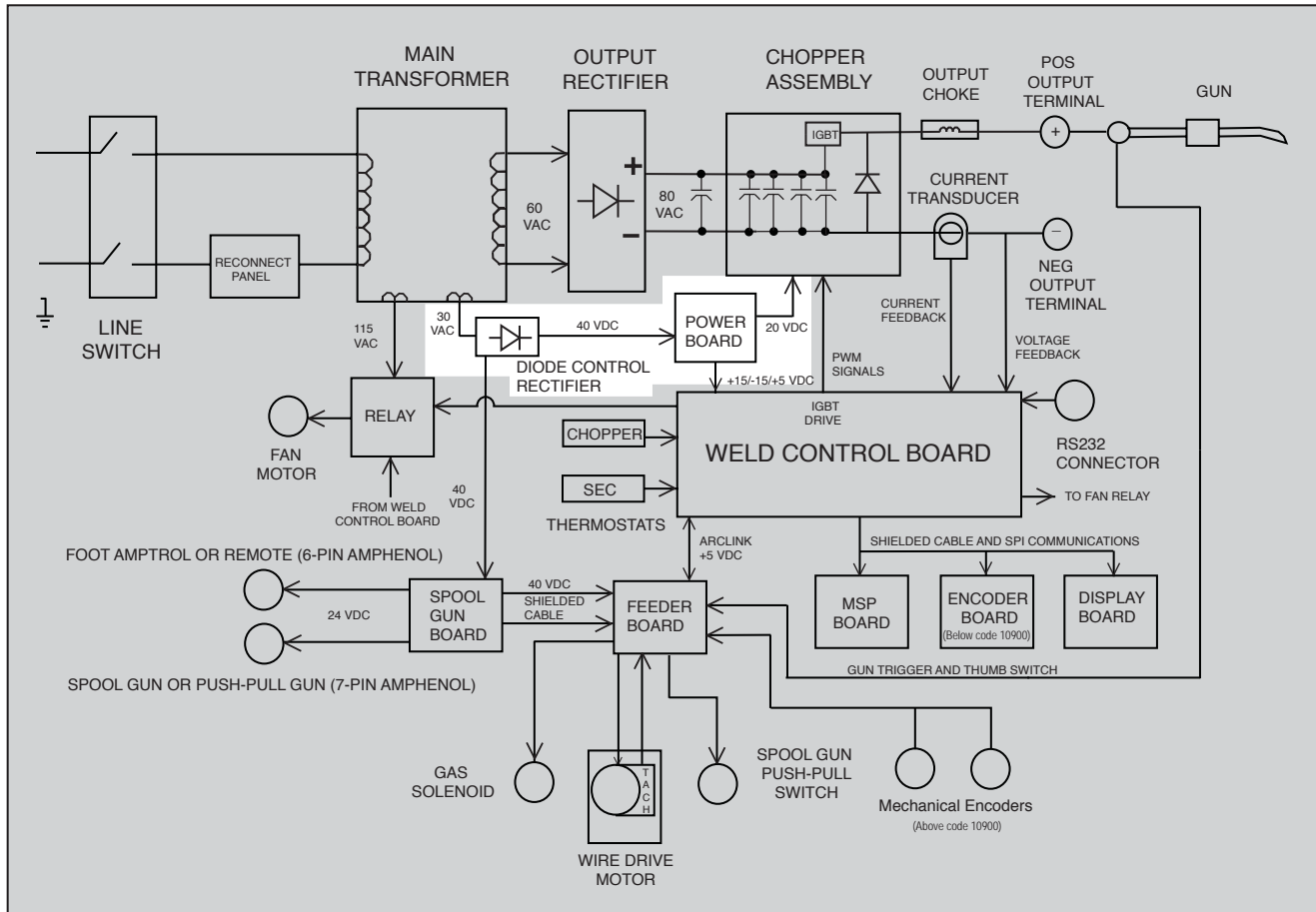

DIODE CONTROL RECTIFIER AND POWER BOARD

The Power Board receives approximately 40 VDC from the Diode Control Rectifier. In turn, the Power Board supplies a variety of regulated DC voltages to the Weld Control Board, which it uses to power its many circuits and communication functions. The Power Board also supplies +20 VDC to the Chopper Assembly.

NOTE: Unshaded areas of Block Logic Diagram are the subject of discussion.

POWER MIG® 300



THEORY OF OPERATION

FIGURE E.6 – WIRE DRIVE MOTOR AND FEEDBACK

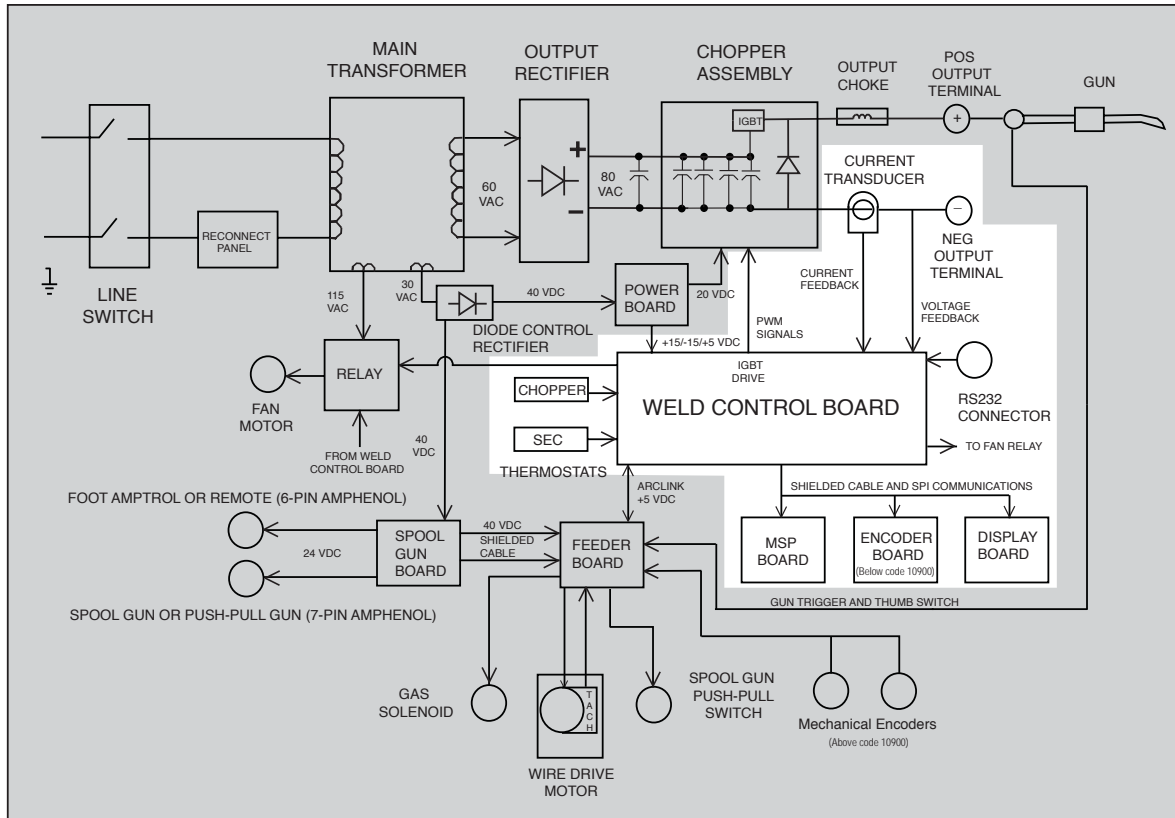

WELD CONTROL BOARD

The Weld Control Board performs the primary interfacing functions to establish and maintain output control of the POWER MIG® 300 machine. The function generator and weld files reside within the Weld Control Board hardware and software. Digital command signals and feedback information from other machine components are received and processed at the Weld Control Board. Software within the Weld Control Board processes the command and feedback information and sends the appropriate pulse width modulation (PWM) signals to the Chopper Assembly IGBT. (See **Pulse Width Modulation** in this section.) In this manner, a digitally controlled high-speed welding waveform is created.

In addition, the Weld Control Board monitors the Chopper thermostat and the Main Transformer secondary winding thermostat. In the event of a fault condition, the Weld Control Board will activate the thermal light and will disable or reduce the machine output.

NOTE: Unshaded areas of Block Logic Diagram are the subject of discussion.

POWER MIG® 300



THEORY OF OPERATION

THERMAL PROTECTION

Two normally closed (NC) thermostats protect the machine from excessive operating temperatures. These thermostats are wired in series and are connected to the Weld Control board. One of the thermostats is located on the Chopper Assembly board, and one is on the secondary of the Main Transformer. Excessive temperatures may be caused by a lack of cooling air or by operating the machine beyond its duty cycle or output rating. If excessive operating temperatures should occur, the thermostats will prevent output from the machine. The yellow thermal light, located on the front of the machine, will be illuminated. The thermostats are self resetting once the machine cools sufficiently. If the thermostat shutdown was caused by excessive output or duty cycle and the fan is operating normally, the power switch may be left on and the reset should occur within a 15-minute period. If the fan is not turning or the intake air louvers are obstructed, the power must be removed from the machine and the fan condition or air obstruction corrected. The cooling fan runs only when necessary. The F.A.N. (fan as needed) system is controlled by the Weld Control Board via solid state relay.

OVER CURRENT PROTECTION

If the average current exceeds 300 to 320 amps, the peak current will be limited to 100 amps until the system is re-triggered or the average current decreases to under 50 amps.

WIRE FEEDER OVERLOAD PROTECTION

The POWER MIG® 300 wire drive motor has its own solid state overload protection. If the motor becomes overloaded, the protection circuitry turns off the wire feed and the gas solenoid. Overload may result from improperly sized tip liner and drive rolls, obstructions or bends in the gun cable, and any other factors that would impede the wire feeding. To resume welding, simply pull the gun trigger. There is no circuit breaker to reset, as the protection is provided by reliable solid state electronics.

POWER MIG® 300



Return to Section TOC
Return to Master TOC
Return to Section TOC
Return to Master TOC
Return to Section TOC
Return to Master TOC
Return to Section TOC
Return to Master TOC

THEORY OF OPERATION

FIGURE E.8 – IGBT OPERATION

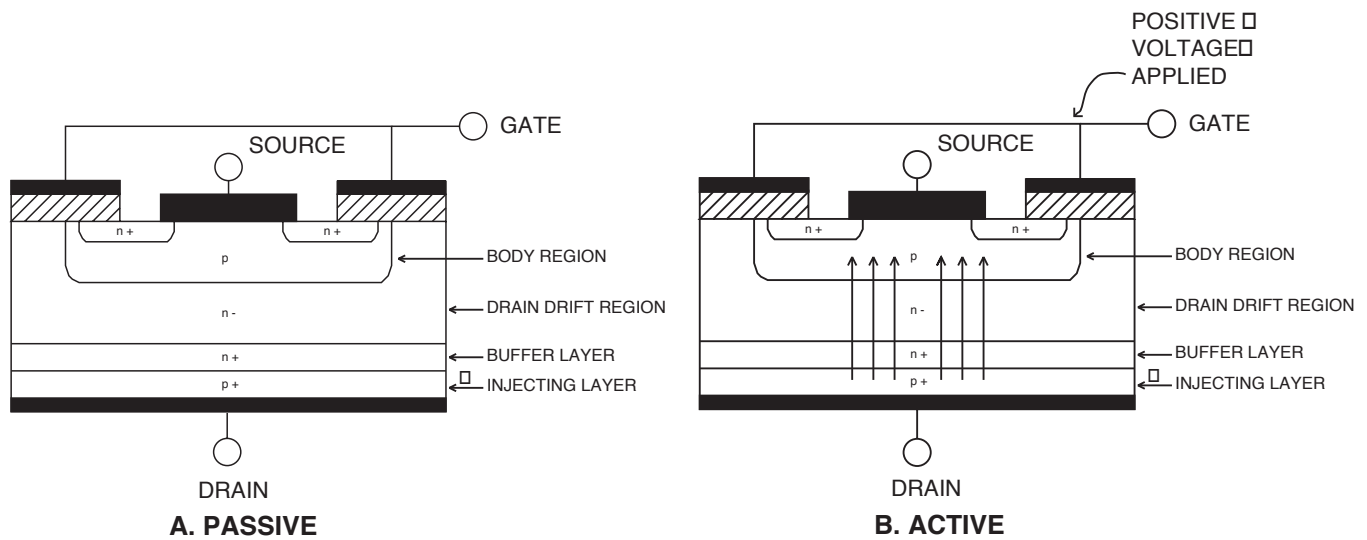

INSULATED GATE BIPOLAR TRANSISTOR (IGBT) OPERATION

An IGBT is a type of transistor. IGBTs are semiconductors well suited for high frequency switching and high current applications.

Drawing A shows an IGBT in a passive mode. There is no gate signal, zero volts relative to the source, and therefore, no current flow. The drain terminal of the IGBT may be connected to a voltage supply; but since there is no conduction the circuit will not supply current to components connected to the source. The circuit is turned off like a light switch in the OFF position.

Drawing B shows the IGBT in an active mode. When the gate signal, a positive DC voltage relative to the source, is applied to the gate terminal of the IGBT, it is capable of conducting current. A voltage supply connected to the drain terminal will allow the IGBT to conduct and supply current to circuit components coupled to the source. Current will flow through the conducting IGBT to downstream components as long as the positive gate signal is present. This is similar to turning ON a light switch.

THEORY OF OPERATION

FIGURE E.9 – TYPICAL IGBT OUTPUTS

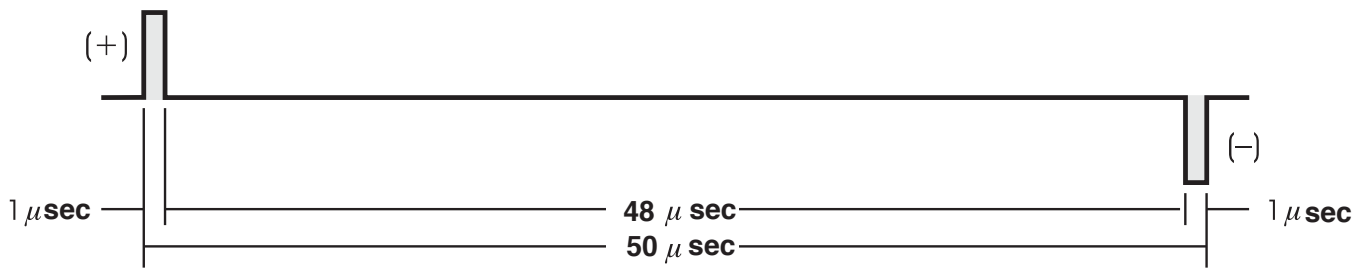

MINIMUM OUTPUT

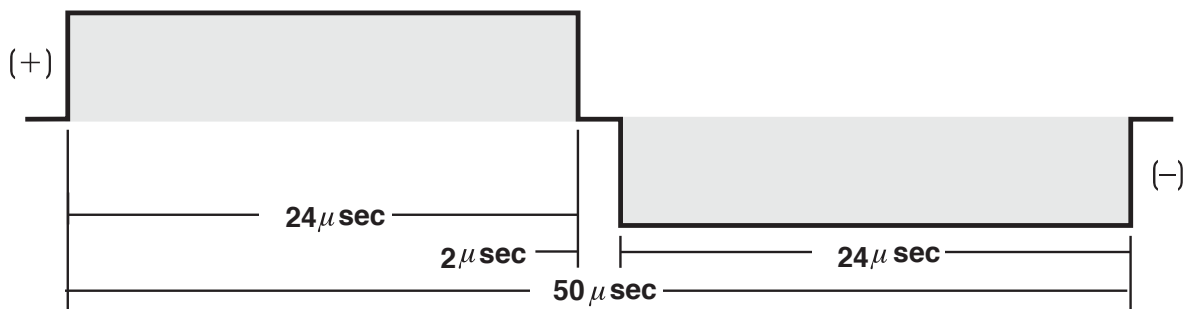

MAXIMUM OUTPUT

PULSE WIDTH MODULATION

The term PULSE WIDTH MODULATION is used to describe how much time is devoted to conduction in the positive and negative portions of the cycle. Changing the pulse width is known as MODULATION. Pulse Width Modulation (PWM) is the varying of the pulse width over the allowed range of a cycle to affect the output of the machine.

MINIMUM OUTPUT

By controlling the duration of the gate signal, the IGBT is turned on and off for different durations during a cycle. The top drawing below shows the minimum output signal possible over a 50-microsecond time period.

The positive portion of the signal represents one

IGBT group conducting for 1 microsecond. The negative portion is the other IGBT group. The dwell time (off time) is 48 microseconds (both IGBT groups off). Since only 2 microseconds of the 50-microsecond time period is devoted to conducting, the output power is minimized.

MAXIMUM OUTPUT

By holding the gate signals on for 48 microseconds each and allowing only 2 microseconds of dwell time (off time) during the 50-microsecond cycle, the output is maximized. The darkened area under the top curve can be compared to the area under the bottom curve. The more dark area under the curve, the more power is present.

THEORY OF OPERATION

CHOPPER TECHNOLOGY FUNDAMENTALS

The new era of welding machines such as the POWER MIG® 300 employ a technology whereby a DC source is turned on and off (chopped up) at high speed, then smoothed through an inductor to control an arc. Hence the name “Chopper.” The biggest advantage of chopper technology is the high-speed control of the arc, similar to the inverter machines. A block diagram for this is as follows:

Figure E.10

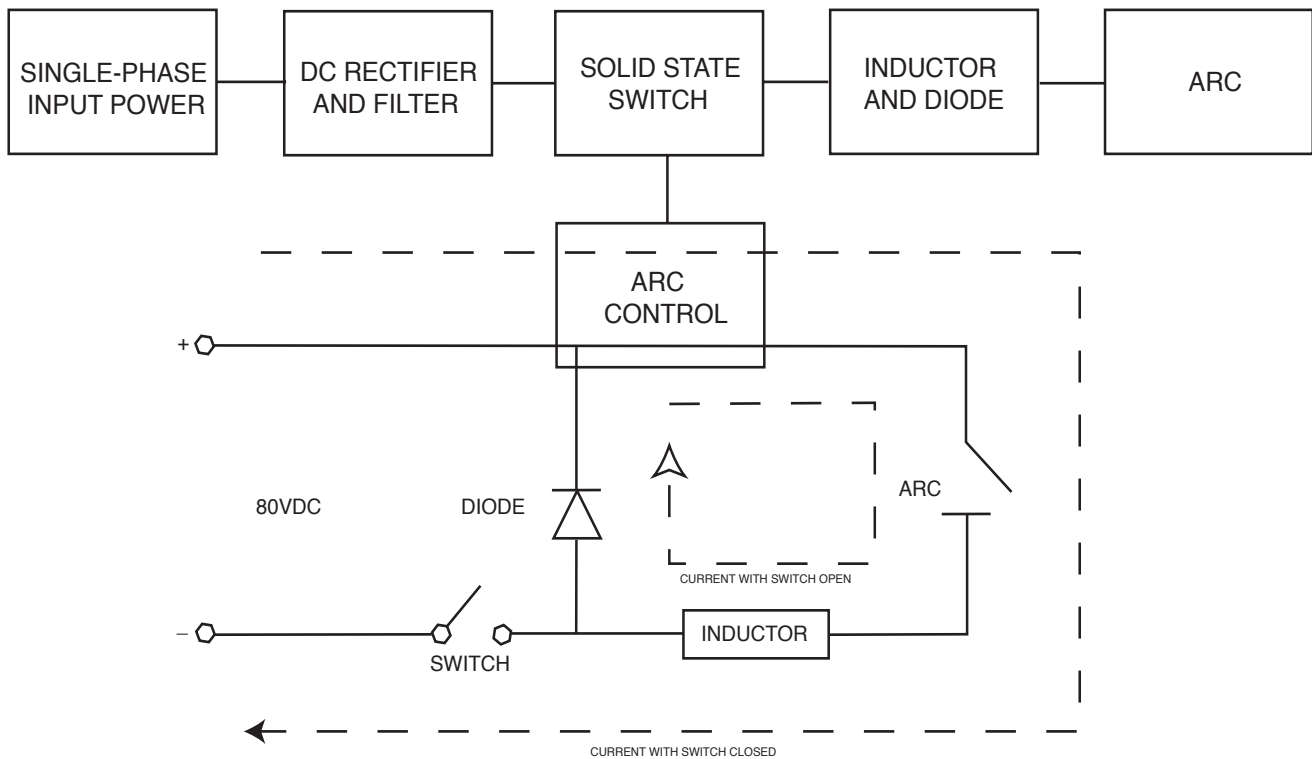

In this system, the engine drives a three-phase alternator, which generates power that is rectified and filtered to produce about 80VDC. The current is applied through a solid state switch to an inductor. By turning the switch on and off, current in the inductor and the arc can be controlled. The above diagram depicts the current flow in the system when the switch is open and closed:

When the switch is closed, current is applied through the inductor to the arc. When the switch opens, current stored in the inductor sustains flow in the arc and through the diode. The repetition rate of switch closure is 20Khz, which allows ultra-fast control of the arc. By varying the ratio of on time versus off time of the switch (Duty Cycle), the current applied to the arc is controlled. This is the basis for Chopper Technology: Controlling the switch in such a way as to produce superior welding.

POWER MIG® 300



NOTES

Return to Section TOC
Return to Master TOC

Return to Section TOC
Return to Master TOC

Return to Section TOC
Return to Master TOC

Return to Section TOC
Return to Master TOC

POWER MIG® 300



TABLE OF CONTENTS

TROUBLESHOOTING & REPAIR SECTION

Troubleshooting & Repair Section	Section F
How to Use Troubleshooting Guide	F-2
PC Board Troubleshooting Procedures	F-3
Troubleshooting Guide	F-4 - F-11
Chopper Board Capacitor Discharge Procedure	F-12
Main Transformer Test	F-14
Chopper Board Test	F-16
Control Rectifier Test.....	F-19
Output Rectifier Assembly Test	F-21
Wire Drive Motor and Tachometer Feedback Test	F-23
Encoder PC Board Test (10562 & Above).....	F-26
Current Transducer Test	F-29
POWER MIG® Scrolling Dashes Test.....	F-32
Oscilloscope Waveforms.....	F-34
Removal and Replacement Procedures	F-36
Motor & Gear Box Removal and Replacement	F-36
Output Rectifier Removal and Replacement	F-40
Chopper Board Assembly Removal and Replacement	F-43
Main Transformer and Output Choke Removal and Replacement.....	F-46
Fan Motor Assembly Removal and Replacement	F-50
Voltage & Current Calibration Procedure	F-52
Retest after Repair.....	F-57

TROUBLESHOOTING & REPAIR

HOW TO USE TROUBLESHOOTING GUIDE



WARNING

Service and repair should be performed by only Lincoln Electric Factory Trained Personnel. Unauthorized repairs performed on this equipment may result in danger to the technician and machine operator and will invalidate your factory warranty. For your safety and to avoid Electrical Shock, please observe all safety notes and precautions detailed throughout this manual.

This Troubleshooting Guide is provided to help you locate and repair possible machine malfunctions. Simply follow the three-step procedure listed below.

Step 1. LOCATE PROBLEM (SYMPTOM).

Look under the column labeled "PROBLEM" (SYMPTOMS). This column describes possible symptoms that the machine may exhibit. Find the listing that best describes the symptom that the machine is exhibiting. Symptoms are grouped into four main categories: Output Problems, Function Problems, Wire Feeding, and Welding Problems.

Step 2. PERFORM EXTERNAL TESTS.

The second column, labeled "POSSIBLE AREAS OF MISADJUSTMENT(S)", lists the obvious external possibilities that may contribute to the machine symptom. Perform these tests/checks in the order listed. In general, these tests can be conducted without removing the case cover.

Step 3. PERFORM COMPONENT TESTS. The last column, labeled "Recommended Course of Action" lists the most likely components that may have failed in your machine. It also specifies the appropriate test procedure to verify that the subject component is either good or bad. If there are a number of possible components, check the components in the order listed to eliminate one possibility at a time until you locate the cause of your problem.

All of the referenced test procedures referred to in the Troubleshooting Guide are described in detail at the end of this section. Refer to the Troubleshooting and Repair Table of Contents to locate each specific Test Procedure. All of the referred to test points, components, terminal strips, etc., can be found on the referenced electrical wiring diagrams and schematics. Refer to the *Machine Schematic* and *Electrical Diagrams* Section Table of Contents to locate the appropriate diagram.



CAUTION

If for any reason you do not understand the test procedures or are unable to perform the test/repairs safely, contact the Lincoln Electric Service Department for electrical troubleshooting assistance before you proceed. Call 1-888-935-3877.

POWER MIG® 300



PC BOARD TROUBLESHOOTING PROCEDURES

⚠ WARNING

**ELECTRIC SHOCK
can kill.**



• Have an electrician install and service this equipment. Turn the input power OFF at the fuse box before working on equipment. Do not touch electrically hot parts.

⚠ CAUTION

Sometimes machine failures appear to be due to PC board failures. These problems can sometimes be traced to poor electrical connections. To avoid problems when troubleshooting and replacing PC boards, please use the following procedure:

1. Determine to the best of your technical ability that the PC board is the most likely component causing the failure symptom.
2. Check for loose connections at the PC board to assure that the PC board is properly connected.
3. If the problem persists, replace the suspect PC board using standard practices to avoid static electrical damage and electrical shock. Read the warning inside the static resistant bag and perform the following procedures:

PC board can be damaged by static electricity.

- Remove your body's static charge before opening the static-shielding bag. Wear an anti-static wrist strap. For safety, use a 1 Meg ohm resistive cord connected to a grounded part of the equipment frame.

- If you don't have a wrist strap, touch an un-painted, grounded, part of the equipment frame. Keep touching the frame to prevent static build-up. Be sure not to touch any electrically live parts at the same time.

- Tools which come in contact with the PC board must be either conductive, anti-static or static-dissipative.

- Remove the PC board from the static-shielding bag and place it directly into the equipment. Don't set the PC board on or near paper, plastic or cloth which could have a static charge. If the PC board can't be installed immediately, put it back in the static-shielding bag.

- If the PC board uses protective shorting jumpers, don't remove them until installation is complete.

- If you return a PC board to The Lincoln Electric Company for credit, it must be in the static-shielding bag. This will prevent further damage and allow proper failure analysis.

4. Test the machine to determine if the failure symptom has been corrected by the replacement PC board.

NOTE: It is desirable to have a spare (known good) PC board available for PC board troubleshooting.

NOTE: Allow the machine to heat up so that all electrical components can reach their operating temperature.

5. Remove the replacement PC board and substitute it with the original PC board to recreate the original problem.
 - a. If the original problem does not reappear by substituting the original board, then the PC board was not the problem. Continue to look for bad connections in the control wiring harness, junction blocks, and terminal strips.
 - b. If the original problem is recreated by the substitution of the original board, then the PC board was the problem. Reinstall the replacement PC board and test the machine.
6. Always indicate that this procedure was followed when warranty reports are to be submitted.

NOTE: Following this procedure and writing on the warranty report, "INSTALLED AND SWITCHED PC BOARDS TO VERIFY PROBLEM," will help avoid denial of legitimate PC board warranty claims.

TROUBLESHOOTING & REPAIR

TROUBLESHOOTING GUIDE

Observe Safety Guidelines detailed in the beginning of this manual.

PROBLEMS (SYMPTOMS)	POSSIBLE AREAS OF MISADJUSTMENT(S)	RECOMMENDED COURSE OF ACTION
OUTPUT PROBLEMS		
Major physical or electrical damage is evident.	1. Contact your local Lincoln Authorized Field Service Facility.	1. Contact the Lincoln Electric Service Department at 1-888-935-3877.
Machine is dead - no welding output and no wire feed when gun trigger is pulled.	<ol style="list-style-type: none"> 1. Make certain that the input power switch is in the "ON" position. 2. Check the input voltage at the machine. Input voltage must match the rating plate and the reconnect panel. 3. Blown or missing fuses in the input line. 4. Check for thermal light on case front. Thermostats may be open due to machine overheating. If machine operates normally after a cooling off period then check for proper fan operation and ventilation. Make certain that the machine's duty cycle is not being exceeded. 5. Remove the gun trigger connection and jump the two connections at the machine. If you have a wirefeed gun, it may be faulty. Replace. 	<ol style="list-style-type: none"> 1. Check for the correct input voltage at the line switch. (L1-L2) See Wiring Diagram. 2. Check for loose or faulty connections between the line switch and the reconnect panel. 3. Perform the Main Transformer Test. 4. Check the red LED's (1 & 2) on the digital power supply board. They should be lit indicating that DC voltage is being applied to plugs J42 and J43. See Wiring Diagram. <p>If LED's 1 & 2 are not lit check for the presence of 42 VDC at plug J41 pin 2(+) and pin 1(-). If the 42 VDC is present and LED's 1 & 2 are not lit the digital power supply board may be faulty.</p> <p>If the 42 VDC is not present at plug J41 perform the Control Rectifier Test.</p>

CAUTION

If for any reason you do not understand the test procedures or are unable to perform the test/repairs safely, contact the Lincoln Electric Service Department for electrical troubleshooting assistance before you proceed. Call 1-888-935-3877.

POWER MIG® 300



Return to Section TOC
Return to Master TOC

TROUBLESHOOTING & REPAIR

TROUBLESHOOTING GUIDE

Observe Safety Guidelines detailed in the beginning of this manual.

PROBLEMS (SYMPTOMS)	POSSIBLE AREAS OF MISADJUSTMENT(S)	RECOMMENDED COURSE OF ACTION
OUTPUT PROBLEMS		
<p>No welding output but wire feeds normally when gun trigger is pulled.</p>	<ol style="list-style-type: none"> 1. Check the input voltage at the machine. Input voltage must match the rating plate and the reconnect panel. 2. The gun may be faulty. Check for continuity. 3. Check continuity through the work lead. 	<ol style="list-style-type: none"> 1. Check for loose or broken connections at the output terminals, the choke and all heavy current carrying leads. See the Machine Schematic. 2. Make sure that the transformer secondary leads are securely connected to the Output Rectifier assembly. 3. Check for OCV at output studs when trigger is pulled. If OCV is present, the gun may be faulty. Replace. 4. Check for 57VAC at the input of output rectifier. If reading is not correct Perform Main Transformer Tests. If you measure approximately 57 VAC, check for 80VDC at the output of the output rectifier. If reading is not correct perform the Output Rectifier Assembly Tests. If 80VDC is there Perform Chopper Board Test. 5. Check for 15VDC input to the Control Board at leads 12J4 (412) to 10J4 (410), -15VDC at leads 11J4 (411) to 10J4 (410), 5VDC at leads 8J4 (408) to 10J4 (410). If missing a voltage check wiring back to Digital Power Supply PCB. If voltage is ok, the Control Board may be faulty. Replace.

 **CAUTION**

If for any reason you do not understand the test procedures or are unable to perform the test/repairs safely, contact the Lincoln Electric Service Department for electrical troubleshooting assistance before you proceed. Call 1-888-935-3877.

Return to Section TOC
Return to Master TOC

TROUBLESHOOTING & REPAIR

Observe Safety Guidelines detailed in the beginning of this manual.

TROUBLESHOOTING GUIDE

PROBLEMS (SYMPTOMS)	POSSIBLE AREAS OF MISADJUSTMENT(S)	RECOMMENDED COURSE OF ACTION
OUTPUT PROBLEMS		
<p>Wire feeds but welding output is low causing wire to “stub”. Welds are “cold”. Machine cannot obtain full rated output of 300 amps at 32 volts.</p>	<ol style="list-style-type: none"> 1. Make sure that the proper wire and procedures are being used. 2. Check gun and work cable for loose or faulty connections. 	<ol style="list-style-type: none"> 1. Check for loose or faulty connections of the heavy current carrying leads. See Wiring Diagram 2. Perform the Current Transducer Test. 3. Perform Output Waveform Test. 4. Perform the Output Rectifier Assembly Tests 5. The Control Board may be faulty. Replace.
<p>The output voltage and wire feed is present continuously or pulsing when gun trigger is NOT activated.</p>	<ol style="list-style-type: none"> 1. Remove the gun. If the problem is resolved, the gun trigger circuit is faulty. Repair or replace. 2. If problem persists when gun assembly is removed from machine, then the problem is within the POWER MIG® 300. 	<ol style="list-style-type: none"> 1. Find J85 on Feed Head Board and unplug. If the problem still exist Feed Head Board may be faulty.
<p>The output voltage is present continuously when gun trigger is NOT activated. The wire is not feeding.</p>		<ol style="list-style-type: none"> 1. Find J6 on Control PCB and unplug. If output voltage is not present change Control PCB 2. Perform the Chopper Board Test.

 **CAUTION**

If for any reason you do not understand the test procedures or are unable to perform the test/repairs safely, contact the Lincoln Electric Service Department for electrical troubleshooting assistance before you proceed. Call 1-888-935-3877.

Return to Section TOC

Return to Section TOC

Return to Section TOC

Return to Section TOC

Return to Master TOC

Return to Master TOC

Return to Master TOC

Return to Master TOC

TROUBLESHOOTING & REPAIR

TROUBLESHOOTING GUIDE

Observe Safety Guidelines detailed in the beginning of this manual.

PROBLEMS (SYMPTOMS)	POSSIBLE AREAS OF MISADJUSTMENT(S)	RECOMMENDED COURSE OF ACTION
FUNCTION PROBLEMS		
No control of arc voltage. Wire feeding is normal.	1. The arc voltage encoder may be dirty. Rotate several times and check if problem is resolved.	1. The arc voltage encoder may be faulty. Codes 10562 have both Encoders on one board. Codes above 10562 have single Encoders. 2. If machine has code 10562 or lower change Encoder Board. If machine has Code above 10562 Perform Encoder Test. 3. Perform the Chopper Board Test. 4. The Control board may be faulty. Replace.
There is no gas flow when gun trigger is pulled. Wire feeds and weld voltage is present.	1. Check gas source and hoses for leaks or kinks. 2. Check regulator on the tank for the pressure being set to high.	1. Check for 6.5 VDC when trigger is pulled at feedhead Board, Plug J83-3 lead 833 and J83-4 lead 834. See Wiring Diagram. If you read 12 VDC solenoid may be open or a bad connection. Check wiring. Check the gas solenoid by disconnecting it from the Feeder Board (Plug J83-3 & 4) and applying a 12 VDC external supply to the gas solenoid. If the solenoid does NOT activate then it may be faulty. Replace. 2. If 6.5VDC is not present the Feeder board may be faulty. Replace.



CAUTION

If for any reason you do not understand the test procedures or are unable to perform the test/repairs safely, contact the Lincoln Electric Service Department for electrical troubleshooting assistance before you proceed. Call 1-888-935-3877.

POWER MIG® 300



Return to Section TOC

Return to Section TOC

Return to Section TOC

Return to Section TOC

Return to Master TOC

Return to Master TOC

Return to Master TOC

Return to Master TOC

Observe Safety Guidelines detailed in the beginning of this manual.

TROUBLESHOOTING GUIDE

PROBLEMS (SYMPTOMS)	POSSIBLE AREAS OF MISADJUSTMENT(S)	RECOMMENDED COURSE OF ACTION
WIRE FEEDING PROBLEMS		
No control of wire feed speed. Other machine functions are normal.	<ol style="list-style-type: none"> The wire feed speed encoder control may be dirty. Rotate several times and check if problem is resolved. 	<ol style="list-style-type: none"> Perform the Wire Drive Motor and Tachometer Feedback Test. The Wire Speed Encoder may be faulty. If code is 10562 or below change Encoder PCB. If code is above 10562 Perform Encoder Test The Feeder Head Board may be faulty. Replace.
There is no wire feed when gun trigger is pulled. Normal open circuit voltage is present.	<ol style="list-style-type: none"> Check for wire jam at drive rolls. If the drive rolls are turning then check for a mechanical restriction in the wire feed path. The gun liner may be clogged. Check or replace. 	<ol style="list-style-type: none"> Perform the Wire Drive Motor and Tachometer Feedback Test. The Wire Speed Control Encoder may be faulty. If code is 10562 and below change Encoder PCB. If code is above 10562 Perform Encoder Test The Feeder Head Board may be faulty. Replace.
The machine stops feeding wire while welding.	<ol style="list-style-type: none"> Check for adequate wire supply. Check for mechanical restrictions in the wire feeding path. The gun may be clogged. Make sure the gun liner and tip are correct for wire size being used. Check spindle for ease of rotation. Check to see if the spot timer has been activated. 	<ol style="list-style-type: none"> Check the motor armature current. Normal armature current is 2.0 to 2.7 amps maximum. If the motor armature current is normal the Feeder Board may be faulty. Replace. If the motor armature current is high (over 2.7 amps) and there are NO restrictions in the wire feeding path then the motor or gear box may be defective. Replace.

CAUTION

If for any reason you do not understand the test procedures or are unable to perform the test/repairs safely, contact the Lincoln Electric Service Department for electrical troubleshooting assistance before you proceed. Call 1-888-935-3877.

Return to Section TOC
Return to Master TOC

TROUBLESHOOTING & REPAIR

TROUBLESHOOTING GUIDE

Observe Safety Guidelines detailed in the beginning of this manual.

PROBLEMS (SYMPTOMS)	POSSIBLE AREAS OF MISADJUSTMENT(S)	RECOMMENDED COURSE OF ACTION
WELDING PROBLEMS		
The arc is unstable and or "hunting."	<ol style="list-style-type: none"> 1. Check for worn or melted contact tip. 2. Check for loose or faulty connections on the work and electrode cables. 3. Make sure electrode polarity or welding process being used is correct. 4. Check for rusty or dirty wire. 5. Make sure machine settings are correct for process being used. (shielding gas, wire type, wire size). 	<ol style="list-style-type: none"> 1. Check for loose connections at the output terminals, the chokes, and all heavy current carrying leads. See the Machine Diagram. 2. Make sure that the transformer secondary leads are securely connected to the Output Rectifier assembly. 3. Check the Output Voltage Waveforms. If waveforms are not correct Perform the Output Rectifier Assembly Tests. 4. Reload latest software. Contact a Lincoln Electric sales representative for latest software. 5. The Control board may be faulty. Replace.
Weld bead is narrow or ropy. May have porosity with electrode stubbing into plate.	<ol style="list-style-type: none"> 1. Make sure the weld procedure and electrode polarity is correct for the process being used. Welding voltage may be too low for wire feed speed being used. 2. Make sure shielding gas is correct and flow is proper. 3. Make sure the weld joint is not "contaminated". 	<ol style="list-style-type: none"> 1. Check the Output Voltage Waveforms. If waveforms are not correct Perform the Output Rectifier Assembly Tests. 2. Reload latest software. Contact a Lincoln Electric sales representative for latest software. 3. The Control board may be faulty. Replace.

 **CAUTION**

If for any reason you do not understand the test procedures or are unable to perform the test/repairs safely, contact the Lincoln Electric Service Department for electrical troubleshooting assistance before you proceed. Call 1-888-935-3877.

POWER MIG® 300



Return to Section TOC
Return to Master TOC

TROUBLESHOOTING & REPAIR

Observe Safety Guidelines detailed in the beginning of this manual.

TROUBLESHOOTING GUIDE

PROBLEMS (SYMPTOMS)	POSSIBLE AREAS OF MISADJUSTMENT(S)	RECOMMENDED COURSE OF ACTION
WELDING PROBLEMS		
The contact tip seizes in the gas diffuser.	<ol style="list-style-type: none"> The tip being over heated due to excessive current and/or high duty cycle welding. A light application of high temperature anti-seize lubricant (such as Lincoln E2607 Graphite Grease) may be applied to the contact tip threads. 	<ol style="list-style-type: none"> Check the Output Voltage Waveforms.
The welding arc is variable and sluggish.	<ol style="list-style-type: none"> Check the welding cable connections for loose or faulty connections. Make sure the wire feed speed, voltage, and shielding gas are correct for the process being used. 	<ol style="list-style-type: none"> Check the OCV and Output Voltage Waveforms. If waveforms are not correct Perform the Output Rectifier Assembly Tests. Reload latest software from a Lincoln Electric sales representative The Control Board may be faulty. Replace.
The arc striking is poor.	<ol style="list-style-type: none"> Check the welding cable connections for loose or faulty connections. Make sure the wire feed speed, voltage, and shielding gas are correct for the process being used. Run in settings may need to be adjusted. 	<ol style="list-style-type: none"> Check the Output Voltage Waveforms. If waveforms are not correct Perform the Output Rectifier Assembly Tests. Reload latest software from a Lincoln Electric sales representative The Control board may be faulty. Replace.

 **CAUTION**

If for any reason you do not understand the test procedures or are unable to perform the test/repairs safely, contact the Lincoln Electric Service Department for electrical troubleshooting assistance before you proceed. Call 1-888-935-3877.

Return to Section TOC

Return to Master TOC

TROUBLESHOOTING & REPAIR

Observe Safety Guidelines detailed in the beginning of this manual.

TROUBLESHOOTING GUIDE

FAULT CODES	DESCRIPTION / DEFINITION	CORRECTIVE ACTION	SERVICE FACILITY CORRECTIVE ACTION
WELDING PROBLEMS			
39	Glitch on the primary over current fault interrupt; possibly caused by noise or a signal level.	Check the machine ground. Check for cuts or marks on input cord.	Check input cord for cuts or marks. Check input cord connections at reconnect panel.
44	Main CPU problem. The DSP has detected a problem with the CPU.	Check the machine ground. Check for cuts or marks on input cord.	Check input cord for cuts or marks. Check input cord connections at reconnect panel. If still bad replace Control PCB.
47	Glitch on the CAP/heart beat interrupt; possibly caused by noise or a signal level right at the trip threshold.	Turn machine off and let sit for 60 second and then turn back on .	Run Scrolling dash Test. If still bad replace Control PCB.
81	Motor overload-average motor current exceeded 8.00 amps for more than 0.50 seconds.	Verify motor armature is not binding. Verify wire spool is not binding.	Check current at drive motor exceeds 8 amps change drive motor. If under 8 amps for 0.50 seconds change Feeder Board.
82	Motor over current-average motor current exceeded 3.50 amps for more than 10.0 seconds.	Verify motor armature is not binding. Verify wire spool is not binding.	Check current at drive motor exceeds 3.50amps for 10.0 seconds change drive motor.
214	Feed Head Board can't be found.	Turn the machine off and back on to reset the machine. If condition persists, contact and authorized Lincoln Field Service Facility.	Using machine schematic Check LED 8 on Control Bd. If not on, check for +5VDC at leads 1103 & 1104. If LED 8 is on check for 42VDC at Feed Head Bd. If there, Feed Head Bd. may be faulty.
7135	MSP can't be found.	Turn the machine off and back on to reset the machine.	Check for bad connections at MSP panel. The MSP panel may be faulty. Replace.
7138	Display Board can't be found.	Turn the machine off and back on to reset the machine.	Check for bad connections at Display Board. The Display Board may be faulty. Replace.
-----	Scrolling dashes	Perform Clear all test.	Perform Clear all test.

CAUTION

If for any reason you do not understand the test procedures or are unable to perform the test/repairs safely, contact the Lincoln Electric Service Department for electrical troubleshooting assistance before you proceed. Call 1-888-935-3877.

POWER MIG® 300



Return to Section TOC

Return to Master TOC

CHOPPER BOARD CAPACITOR DISCHARGE PROCEDURE



WARNING

Service and repair should be performed by only Lincoln Electric factory trained personnel. Unauthorized repairs performed on this equipment may result in danger to the technician or machine operator and will invalidate your factory warranty. For your safety and to avoid electrical shock, please observe all safety notes and precautions detailed throughout this manual.

If for any reason you do not understand the test procedures or are unable to perform the test/repairs safely, contact the Lincoln Electric Service Department for electrical troubleshooting assistance before you proceed. Call 1-888-935-3877.

DESCRIPTION

This procedure will insure that the five large capacitors on the Chopper Board have been discharged. This procedure should be performed whenever work is to be attempted on or near the Chopper Board.

MATERIALS NEEDED

- 3/8 in. Nutdriver
- Volt/Ohmmeter
- Resistor (25 ohms and 25 watts minimum)
- Jumper leads
- Wiring Diagram

CHOPPER BOARD CAPACITOR DISCHARGE PROCEDURE *(continued)*

FIGURE F.1 – CHOPPER BOARD CAPACITOR TERMINAL DISCHARGE

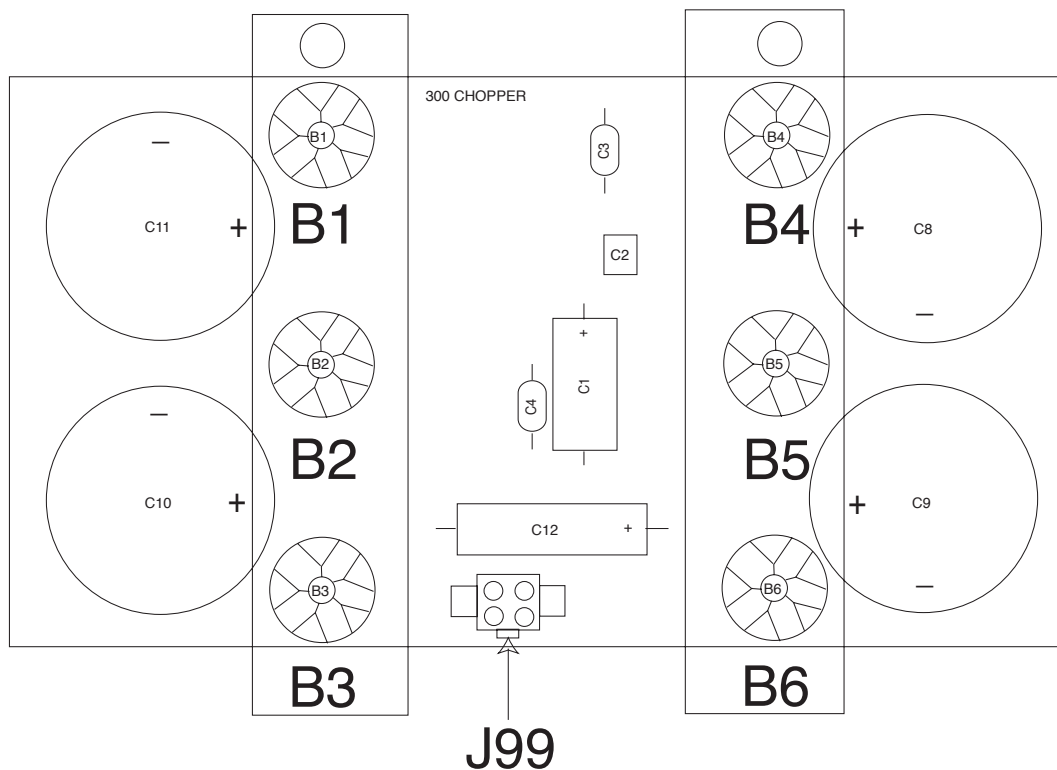

PROCEDURE

⚠ WARNING

ELECTRIC SHOCK can kill.

High voltage is present when input power is applied to the machine.

Refer to Figure F.1.

1. Remove main input power supply to the machine.
2. Lift the hinged right side case cover.
3. Using the 3/8 in. nutdriver, remove the bottom right case cover.
4. Locate the Chopper Board with capacitors mounted on the center of the machine base, right side. See Figure F.1.

5. Using the resistor and jumper leads, CAREFULLY discharge the capacitor terminals. There are 5 capacitors. **NEVER USE A SHORTING STRAP FOR THIS PURPOSE.** DO NOT TOUCH THE TERMINALS WITH YOUR BARE HANDS.

To discharge the capacitors, hold the jumper leads to the following terminals for a minimum of 10 seconds each. See Figure F.1 and the Wiring Diagram.

Capacitors	Terminals
C10 and C11	B1 and B2
C5	B1 and B5
C8 and C9	B4 and B5

6. Using the volt/ohmmeter, check the voltage across terminals B1 and B2 and B1 and B5 and B4 and B5. Each reading should now be zero volts.

Return to Section TOC
Return to Master TOC

MAIN TRANSFORMER TEST



WARNING

Service and repair should be performed by only Lincoln Electric factory trained personnel. Unauthorized repairs performed on this equipment may result in danger to the technician or machine operator and will invalidate your factory warranty. For your safety and to avoid electrical shock, please observe all safety notes and precautions detailed throughout this manual.

If for any reason you do not understand the test procedures or are unable to perform the test/repairs safely, contact the Lincoln Electric Service Department for electrical troubleshooting assistance before you proceed. Call 1-888-935-3877.

TEST DESCRIPTION

This test will determine if the correct voltages are being applied to the primary windings of the main transformer and induced on the secondary and auxiliary windings.

MATERIALS NEEDED

- 3/8 in. Nutdriver
- 5/16 in. Nutdriver
- Volt/Ohmmeter

TROUBLESHOOTING & REPAIR

MAIN TRANSFORMER TEST (continued)

FIGURE F.2 – MAIN TRANSFORMER TEST POINT LOCATIONS

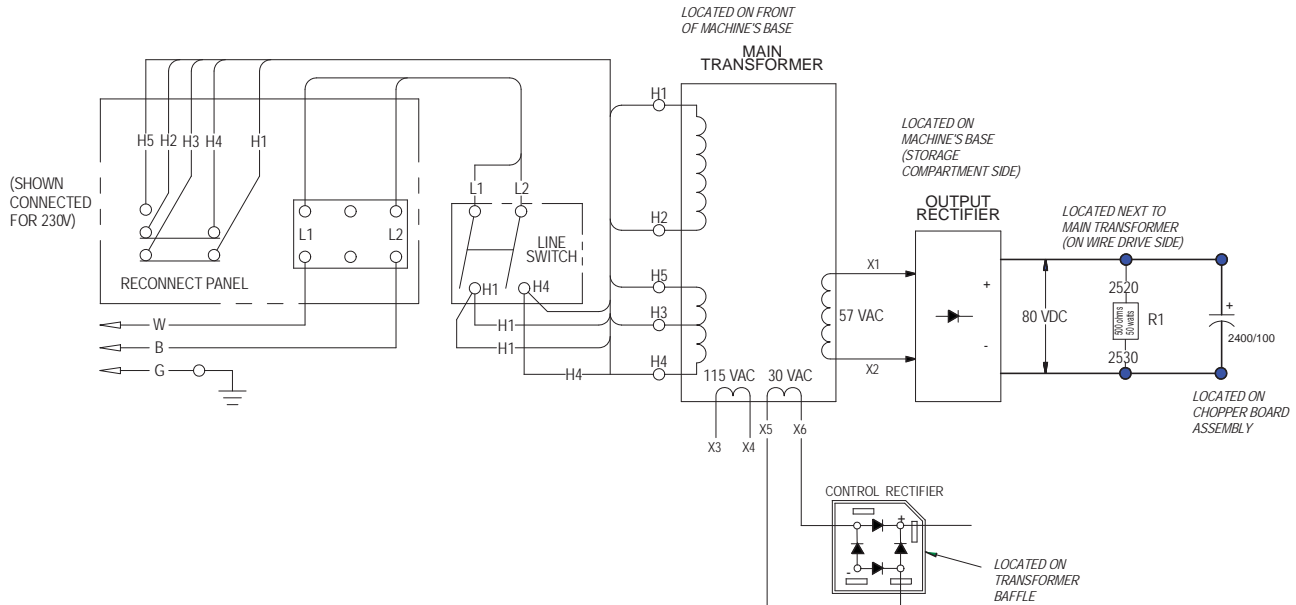

PROCEDURE

WARNING

The ON/OFF POWER SWITCH will be "hot" during these tests.

NOTE: Secondary voltages will vary proportionately with the primary input voltage.

1. Disconnect the main input power supply to the machine.
2. Perform the Case Cover Removal procedure.
3. Remove the tool tray with a 5/16 in. nut-driver (3 screws).

TEST INPUT VOLTAGE TO THE MAIN TRANSFORMER PRIMARY WINDING:

4. Confirm the reconnect panel is connected properly for the correct voltage. See reconnect panel connection diagram located on back of machine above reconnect door.

5. Test for correct input voltage between L1 lead at the LINE SWITCH to L2. Voltage tested will vary depending on the input voltage connection. See Wiring diagram for test point locations.

- * If the voltage is incorrect, check for loose or broken leads between the reconnect panel and the ON/OFF POWER SWITCH. Also, test the ON/OFF POWER SWITCH for proper operation.
- * If the voltage is correct, check for the same voltage at H1 and H4 and at the bottom of the LINE SWITCH with the switch in the ON position.
- * If the voltage is incorrect, check for loose or broken leads between the reconnect panel and the LINE SWITCH.
- * If the correct voltage is being applied to the main transformer primary winding, proceed to the table below for the secondary winding output voltage tests.

Leads	Description	Expected Voltage
X1-X2	Power to output rectifier	57 VAC
X3-X4	Power to fan motor	115 VAC
X5-X6	Power to control rectifier	30 VAC

If the correct voltage is being applied to the main transformer and one or more of the secondary voltages is missing or incorrect, the main transformer may be faulty. Replace the main transformer.

Return to Section TOC

CHOPPER BOARD TEST



WARNING

Service and repair should be performed by only Lincoln Electric factory trained personnel. Unauthorized repairs performed on this equipment may result in danger to the technician or machine operator and will invalidate your factory warranty. For your safety and to avoid electrical shock, please observe all safety notes and precautions detailed throughout this manual.

If for any reason you do not understand the test procedures or are unable to perform the test/repairs safely, contact the Lincoln Electric Service Department for electrical troubleshooting assistance before you proceed. Call 1-888-935-3877.

TEST DESCRIPTION

This test will help determine if the power module IGBT on the Chopper Board is shorted. This test will also check for input voltage and if the PWM signal is present to activate the IGBT. It will also determine if the Chopper Board is receiving the correct input voltages.

MATERIALS NEEDED

Volt/Ohmmeter (Analog)
3/8" Socket wrench and 6" extension
7/16" Nut driver

POWER MIG® 300



TROUBLESHOOTING & REPAIR

CHOPPER BOARD TEST (continued)

TEST PROCEDURE

1. Disconnect the main AC input power to the machine.
2. Remove the case side panels with a 3/8 in. nutdriver.
3. Locate plug J99. (Later machine do not have J99).
4. Make the following voltage test. From the table below.
5. Turn the machine off between each test:
 - a. Carefully insert the meter probes into the back of each Molex plug cavity.

FROM LEAD	TO LEAD	EXPECTED VOLTAGE
437+(1J99)	431-(4J99)	20VDC

If 20 VDC is not present check Digital Power Supply. See the Wiring Diagram.

RESISTANCE TEST

1. Perform the Capacitor Discharge Procedure.
2. Remove input power to the machine.
3. Perform the resistance tests in Table F.1.

Table F.1– CHOPPER BOARD RESISTANCE TEST TABLE

Test Point	Test Point	Expected Reading
B5(+)	B6(-)	6 K ohms - 9K ohms
B6(+)	B5(-)	6 K ohms - 9K ohms
B4(+)	B5(-)	200 K ohms or Higher
B5(+)	B4(-)	400 K ohms or Higher
B4(+)	B6(-)	200 K ohms or Higher
B6(+)	B4(-)	400 K ohms or Higher
B2(+)	B3(-)	6 K ohms - 9K ohms
B3(+)	B2(-)	6 K ohms - 9K ohms
B4(+)	B2(-)	200 K ohms or Higher
B2(+)	B4(-)	400 K ohms or Higher
B4(+)	B3(-)	200 K ohms or Higher
B3(+)	B4(-)	400 K ohms or Higher

FIGURE F.3 – CHOPPER BOARD CONNECTIONS

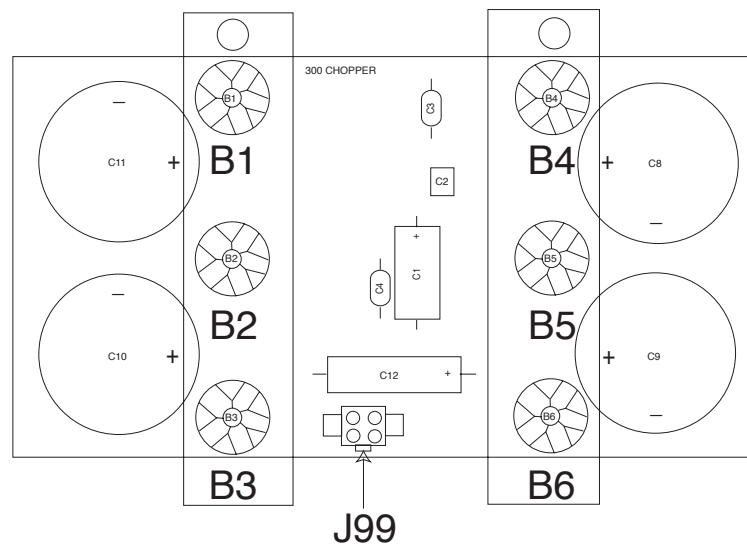

POWER MIG® 300



Return to Section TOC
 Return to Master TOC
 Return to Section TOC
 Return to Master TOC
 Return to Section TOC
 Return to Master TOC
 Return to Section TOC
 Return to Master TOC

CONTROL RECTIFIER TEST



WARNING

Service and repair should be performed by only Lincoln Electric factory trained personnel. Unauthorized repairs performed on this equipment may result in danger to the technician or machine operator and will invalidate your factory warranty. For your safety and to avoid electrical shock, please observe all safety notes and precautions detailed throughout this manual.

If for any reason you do not understand the test procedures or are unable to perform the test/repairs safely, contact the Lincoln Electric Service Department for electrical troubleshooting assistance before you proceed. Call 1-888-935-3877.

DESCRIPTION

This test will determine if the correct AC voltages are being applied to the Rectifier Diode Bridge and supplied from the Rectifier Diode Bridge to the Digital Power Supply board.

MATERIALS NEEDED

- Volt/Ohmmeter
- 3/8" Nut driver
- POWER MIG® 300 Machine Schematic

OUTPUT RECTIFIER ASSEMBLY TEST



WARNING

Service and repair should be performed by only Lincoln Electric factory trained personnel. Unauthorized repairs performed on this equipment may result in danger to the technician or machine operator and will invalidate your factory warranty. For your safety and to avoid electrical shock, please observe all safety notes and precautions detailed throughout this manual.

If for any reason you do not understand the test procedures or are unable to perform the test/repairs safely, contact the Lincoln Electric Service Department for electrical troubleshooting assistance before you proceed. Call 1-888-935-3877.

TEST DESCRIPTION

This test will determine if the Output Rectifier is shorted. See the *Oscilloscope Waveforms* section of this manual for normal and abnormal output waveforms.

MATERIALS NEEDED

Analog Volt/Ohmmeter (If Digital Meter is used you must use in diode check mode.
Do not use ohms scale)

3/8" Nutdriver

5/16" Nutdriver

1/2" Wrench

POWER MIG® 300 Wiring Diagram (See the *Machine Schematic* in this manual)

TROUBLESHOOTING & REPAIR

OUTPUT RECTIFIER ASSEMBLY TEST (continued)

FIGURE F.7– OUTPUT RECTIFIER ASSEMBLY LOCATION

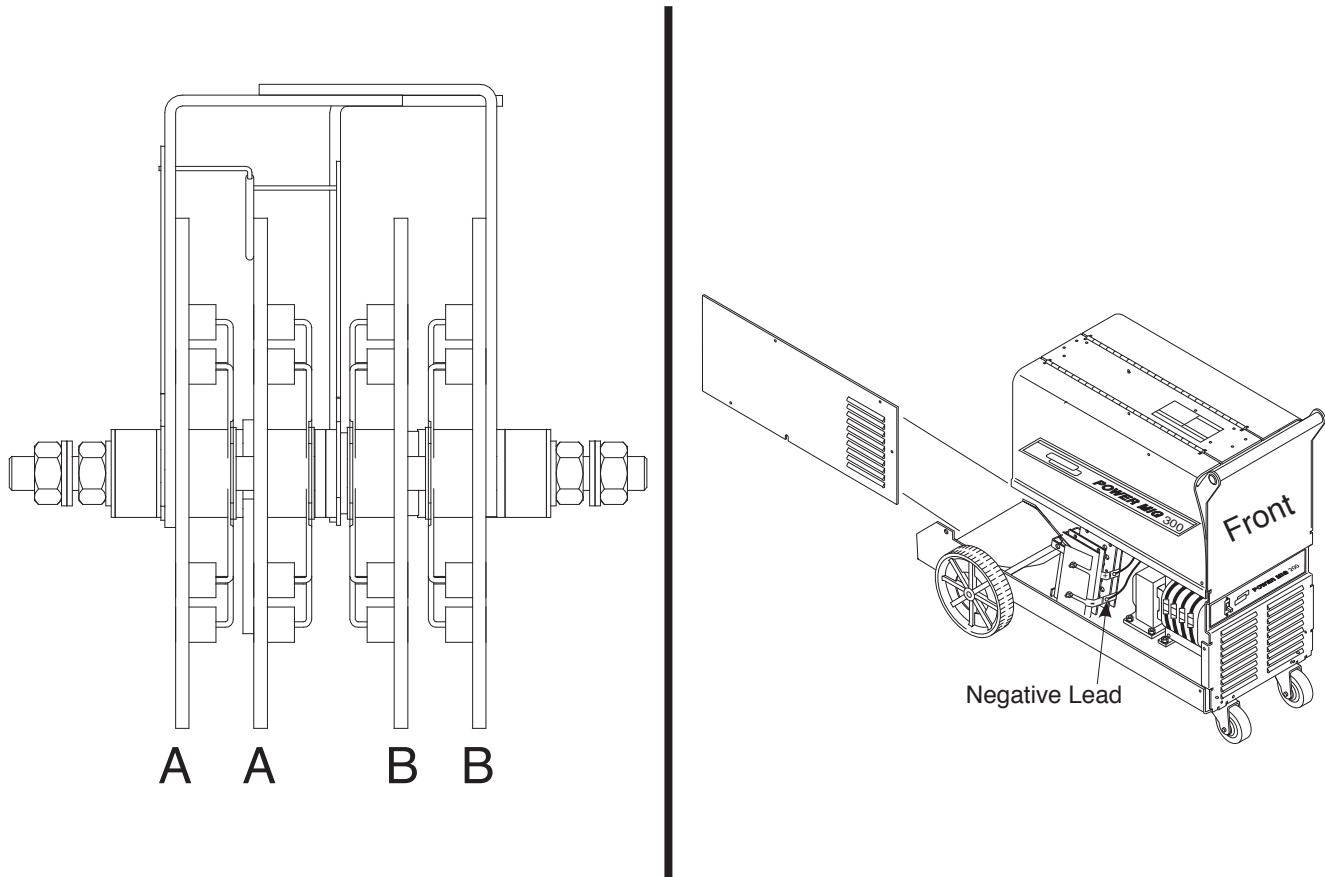

TEST PROCEDURE

1. Disconnect the main AC input power to the machine.
2. Perform the **Chopper Assembly Capacitor Discharge procedure**.
3. Locate and disconnect the negative lead from the output rectifier bridge assembly.
4. Test for shorted or leaky diodes by checking from the outside plate (A) to inside plate (A) then reverse your leads and recheck the same plates. Do the same to plate B. The readings should be high resistance in one polarity and low resistance in the opposite polarity. See Figure F.7.
5. If any of the diodes are leaky or shorted the output rectifier assembly should be replaced.
6. When the test is complete, replace the negative output previously removed.
7. Replace case side.

Note: Do not disassemble the rectifier assembly.

POWER MIG® 300



WIRE DRIVE MOTOR AND TACHOMETER FEEDBACK TEST



WARNING

Service and repair should be performed by only Lincoln Electric factory trained personnel. Unauthorized repairs performed on this equipment may result in danger to the technician or machine operator and will invalidate your factory warranty. For your safety and to avoid electrical shock, please observe all safety notes and precautions detailed throughout this manual.

If for any reason you do not understand the test procedures or are unable to perform the test/repairs safely, contact the Lincoln Electric Service Department for electrical troubleshooting assistance before you proceed. Call 1-888-935-3877.

TEST DESCRIPTION

This test will determine if the wire drive motor and voltage feedback circuits are functioning properly.

MATERIALS NEEDED

5/16" Nutdriver
Volt/Ohmmeter

POWER MIG® 300



TROUBLESHOOTING & REPAIR

WIRE DRIVE MOTOR AND TACHOMETER FEEDBACK TEST (continued)

FIGURE F. 8 – PLUG J83 AND J84 LOCATIONS ON FEEDER BOARD

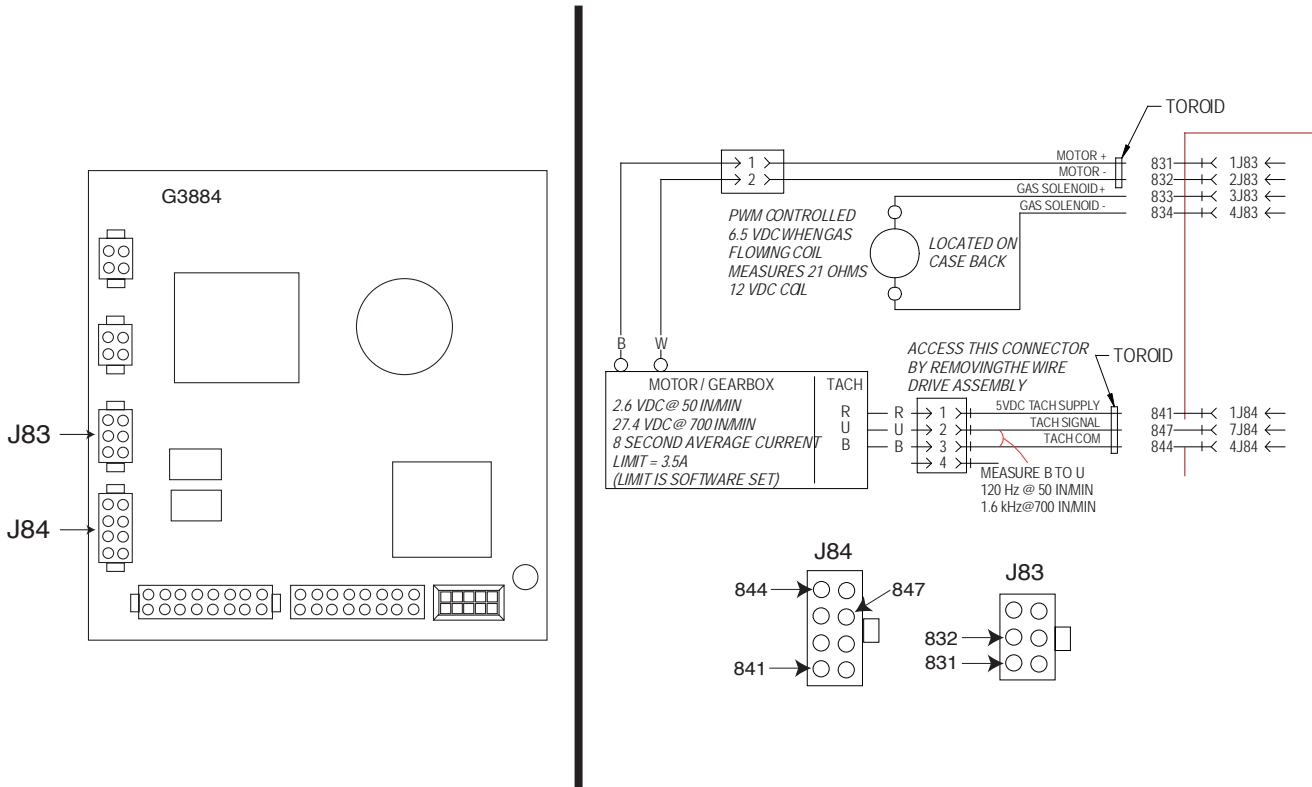

TEST PROCEDURE

NOTE: POLARITY MUST BE OBSERVED FOR THESE TESTS.

TEST FOR CORRECT WIRE DRIVE MOTOR ARMATURE VOLTAGE

1. Disconnect main input power to the machine.
2. Open the side panels and remove the tool tray using a 5/16 in. nutdriver.
3. Locate the following leads on plug J83:
4. Locate leads 831(black) and 832(white) on plug J83.
5. Connect the main power to the machine.
7. Make the following voltage tests. From the table below.
8. Carefully insert the meter probes into the back of each Molex plug pin cavity to perform the test.
9. Turn the machine ON and pull the gun trigger to conduct this voltage test.

FROM LEAD	TO LEAD	EXPECTED VOLTAGE
831 + (1J83)	832 - (2J83)	2.5-27 VDC (varies depending on wire feed speed)

POWER MIG® 300



Return to Section TOC
 Return to Master TOC
 Return to Section TOC
 Return to Master TOC
 Return to Section TOC
 Return to Master TOC
 Return to Section TOC
 Return to Master TOC

TROUBLESHOOTING & REPAIR

WIRE DRIVE MOTOR AND TACHOMETER FEEDBACK TEST *(continued)*

TEST FOR SUPPLY VOLTAGE TO TACHOMETER AND FEEDBACK VOLTAGE

1. Locate the following leads on Plug J84. Leads 841 (1J84) and 844 (4J84)
2. Make the following voltage tests. From the table below.
3. Turn the machine OFF between each test.
4. Carefully insert the meter probes into the back of each Molex plug pin cavity. This is the tach supply voltage.

FROM LEAD	TO LEAD	EXPECTED VOLTAGE
841 + (1J84)	844 - (4J84)	5 VDC

5. If the 5 VDC is present, go to next step. If no voltage is measured Feeder Head Board may be bad. Check connections back to Feed Head Board.
6. Locate the leads on Plug J84 noted in the table below.
7. Carefully insert the meter probes into the back of each Molex plug pin cavity
8. Turn the machine ON and pull the gun trigger to conduct the voltage test.

FROM LEAD	TO LEAD	EXPECTED VOLTAGE
847 + (7J84)	844 - (4J84)	1.5 to 3.5 VDC

9. If the 1.5 to 3.5 VDC is present, the tachometer circuit is sending the correct feedback signal to the Feeder Board. Replace the Feeder Board.
10. If the 1.5 to 3.5 VDC is not present or not correct, the Feeder Board is not receiving the proper feedback voltage from the tachometer circuit. Check the leads from the tachometer circuit to the Feeder Board for loose or broken connections.
11. If the leads are okay, the tachometer circuit may be faulty, replace the tach Sensor.

Return to Section TOC
Return to Master TOC

TROUBLESHOOTING & REPAIR

ENCODER PC BOARD TEST (FOR CODES ABOVE 10562)



WARNING

Service and repair should be performed by only Lincoln Electric factory trained personnel. Unauthorized repairs performed on this equipment may result in danger to the technician or machine operator and will invalidate your factory warranty. For your safety and to avoid electrical shock, please observe all safety notes and precautions detailed throughout this manual.

If for any reason you do not understand the test procedures or are unable to perform the test/repairs safely, contact the Lincoln Electric Service Department for electrical troubleshooting assistance before you proceed. Call 1-888-935-3877.

DESCRIPTION

This test will help determine if the encoders are functioning properly for machines above code 10562 only.

MATERIALS NEEDED

Volt/Ohmmeter (analog recommended)
5/16" Nut driver

POWER MIG® 300



TROUBLESHOOTING & REPAIR

ENCODER PC BOARD TEST (continued)

FIGURE F. 9 - FEEDHEAD P.C. BOARD

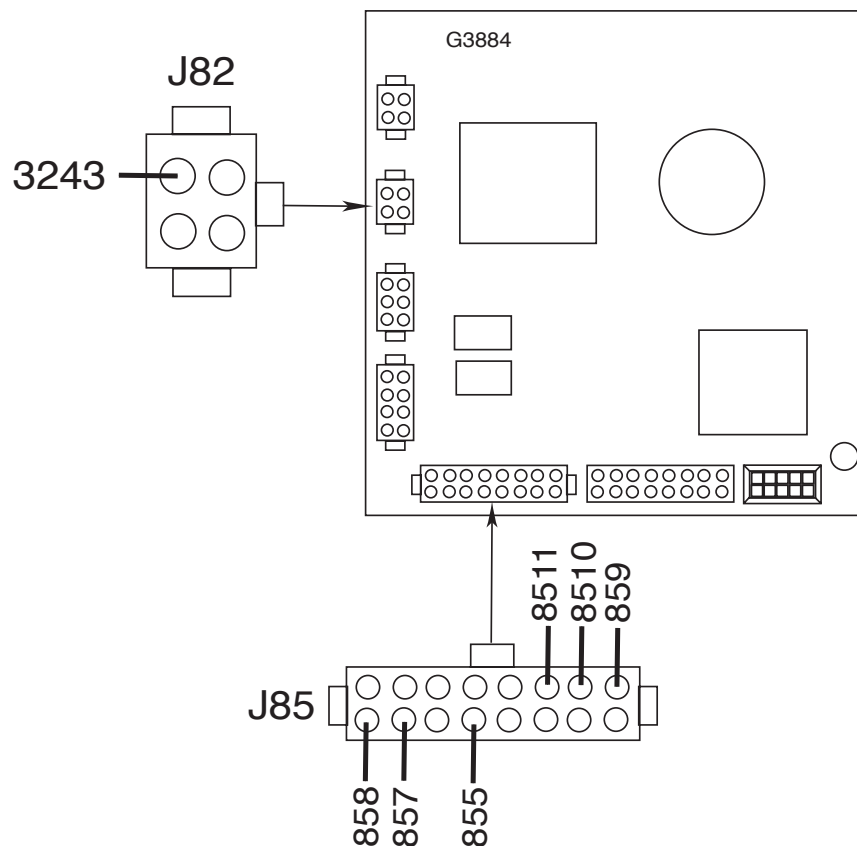

TEST PROCEDURE

1. Disconnect the main AC input power to the machine.
2. Locate the following leads on Plug J85 and J86 located on the feedhead P.C. Board. See Figure F.9.
3. Connect main input power to the machine.
4. Make the following voltage tests. From the tables on following page.
5. Turn the machine OFF between each test.
6. Carefully insert the meter probes into the back of each Molex plug pin cavity.
7. As you turn the encoder **slowly** the voltage will change from zero to 15 volts to zero, to 15 volts etc. as you continue to turn the encoder.

TROUBLESHOOTING & REPAIR

ENCODER PC BOARD TEST *(continued)*

VOLT/TRIM ENCODER #1			
FROM LEAD	TO LEAD	EXPECTED VOLTAGE	ACTION
855 5J85	3243 3J82	15 VDC	If you do not read 15VDC on the first reading of encoder #1 or #2 then check lead connections. If lead connections check OK, then Feeder Board may be faulty, replace Feeder Board.
8511 11J85	3243 3J82	0 OR 15 VDC	As you turn the encoder #1 or #2 slowly you should see your meter go from 0 to 15, 0 to 15 as you turn the encoder. If not, check the lead connections. If the lead connection check OK then, change the encoder.
858 8J85	3243 3J82	0 OR 15 VDC	

WMF/AMPS ENCODER #2			
FROM LEAD	TO LEAD	EXPECTED VOLTAGE	ACTION
859 9J85	3243 3J82	15 VDC	If you do not read 15VDC on the first reading of encoder #1 or #2 then check lead connections. If lead connections check OK, then Feeder Board may be faulty, replace Feeder Board.
857 7J85	3243 3J82	0 OR 15 VDC	As you turn the encoder #1 or #2 slowly you should see your meter go from 0 to 15, 0 to 15 as you turn the encoder. If not, check the lead connections. If the lead connection check OK then, change the encoder.

TROUBLESHOOTING & REPAIR

CURRENT TRANSDUCER TEST



WARNING

Service and repair should be performed by only Lincoln Electric factory trained personnel. Unauthorized repairs performed on this equipment may result in danger to the technician or machine operator and will invalidate your factory warranty. For your safety and to avoid electrical shock, please observe all safety notes and precautions detailed throughout this manual.

If for any reason you do not understand the test procedures or are unable to perform the test/repairs safely, contact the Lincoln Electric Service Department for electrical troubleshooting assistance before you proceed. Call 1-888-935-3877.

DESCRIPTION

This test will determine if the current transducer and associated wiring are functioning correctly.

MATERIALS NEEDED

Volt/Ohmmeter
3/8" Nut driver

POWER MIG® 300



TROUBLESHOOTING & REPAIR

CURRENT TRANSDUCER TEST (continued)

FIGURE F.10

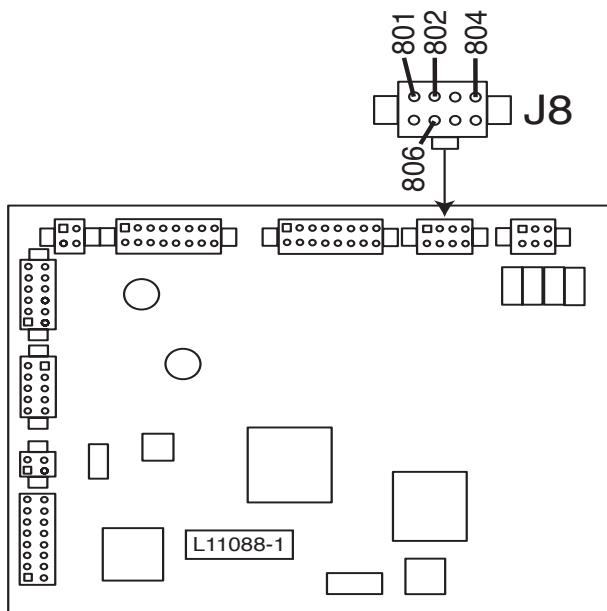

TEST PROCEDURE

1. Remove input power to the machine
2. Remove the left case side of the machine.
3. Remove the PC compartment door.
4. Locate plug J8 at the Control Board. See Figure F.10.
5. Connect the main power to the machine.
6. Make the following voltage test. From the table below. Also see **Table F.2**.
7. Carefully insert the meter probes into the back of each Molex plug pin cavity.

FROM LEAD	TO LEAD	EXPECTED VOLTAGE
802+ (2J8)	806- (6J8)	+15 VDC

8. If excepted voltages are not present the Control Board may be faulty.
9. Check the feedback voltage from the current transducer with the POWER MIG® set on Mode 1 or 2 and the machine loaded to 250 amps.
10. Make the following voltage test. From the table below.
11. If the measured feedback voltage is not correct for the output load current. The current transducer may be faulty.

FROM LEAD	TO LEAD	EXPECTED VOLTAGE
801 (1J8)	806 (6J8)	2.0 VDC

12. If for any reason the machine cannot be loaded to 250 amps, **Table F.2** shows what feedback voltage is produced at various current loads.

Return to Section TOC
Return to Master TOC

TROUBLESHOOTING & REPAIR

CURRENT TRANSDUCER TEST (*continued*)

Table F.2 – Current Transducer Feedback Voltage

OUTPUT LOAD CURRENT	EXPECTED TRANSDUCER FEEDBACK VOLTAGE
500	4.0
450	3.6
400	3.2
350	2.8
300	2.4
250	2.0
200	1.6
150	1.2
100	0.8

POWER MIG® 300



Return to Section TOC

Return to Master TOC

Return to Section TOC

Return to Master TOC

Return to Section TOC

Return to Master TOC

Return to Section TOC

Return to Master TOC

TROUBLESHOOTING & REPAIR

POWER MIG® 300 SCROLLING DASHES TEST



WARNING

Service and repair should be performed by only Lincoln Electric factory trained personnel. Unauthorized repairs performed on this equipment may result in danger to the technician or machine operator and will invalidate your factory warranty. For your safety and to avoid electrical shock, please observe all safety notes and precautions detailed throughout this manual.

If for any reason you do not understand the test procedures or are unable to perform the test/repairs safely, contact the Lincoln Electric Service Department for electrical troubleshooting assistance before you proceed. Call 1-888-935-3877.

DESCRIPTION

ERROR CODE: Scrolling dashes on the POWER MIG® 300 perform the appropriate clear all procedure as follows.

MATERIALS NEEDED

None

POWER MIG® 300



Return to Section TOC
Return to Master TOC
Return to Section TOC
Return to Master TOC
Return to Section TOC
Return to Master TOC
Return to Section TOC
Return to Master TOC
Return to Section TOC
Return to Master TOC

TROUBLESHOOTING & REPAIR

POWER MIG® 300 SCROLLING DASHES TEST (*continued*)

TEST PROCEDURES:

For Machines with code 10952, 10958 and 11000.

1. Hold “select” switch up while powering up machine.
2. Release “select” switch when displays show “PrESSPin”.
3. Turn the right “encoder knob” until displays show “CLrAll”.
4. Toggle the “select” switch up and release.
5. Machine will reset itself.

For Machines with code 10562.

1. Hold “select” switch up while powering up machine.
2. Continue to hold “select” switch up and turn right “encoder” until display reads “CLrAll”.
3. Release the “select” switch.
4. Machine will reset itself.

TROUBLESHOOTING & REPAIR

OSCILLOSCOPE WAVEFORMS MUST BE TAKEN IN MODE 201

NORMAL OPEN CIRCUIT VOLTAGE WAVEFORM

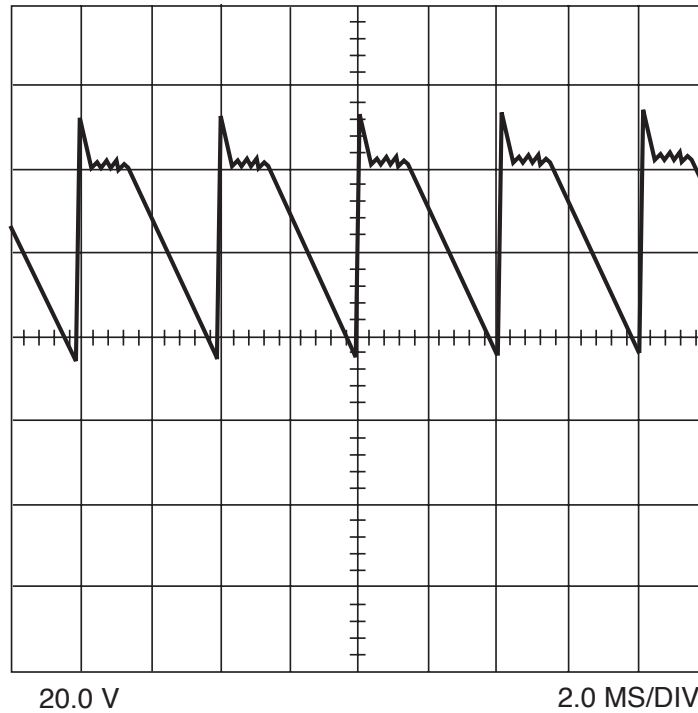

This is a typical DC output voltage waveform generated from a properly operating machine. Note that each vertical division represents 20 volts and that each horizontal division represents 2.00 milliseconds in time.

NOTE: Scope probes connected at the machine output terminals: (+) probe to electrode, (-) probe to work.

SCOPE SETTINGS

Volts/Div	20V/Div.
Horizontal Sweep ..	2.5 ms/Div.
Coupling	DC
Trigger	Internal

CODES 10562 AND BELOW

POWER MIG® 300 in mode 201. Mode 201 is a constant current test mode.

1. Toggle and hold the Mode Select switch in the up position.
2. Turn on the POWER MIG® 300.
3. Rotate the right output knob, while still holding the Mode Select switch up, until the display reads "ALL node".
4. Release the Mode Select switch and toggle the Mode Set switch until the MSPIII panel reads 201. Disengage the idler arm on the wire drive so no wire will feed.

CODES 10952 AND UP

POWER MIG® 300 in mode 201. Mode 201 is a constant current test mode.

1. Toggle and hold the Mode Select switch in the up position.
2. Turn on the POWER MIG® 300.
3. Once the display reads "Pres Spin" release the mode select switch. Rotate the output knob until the display reads "ALL node".
4. Toggle the Mode Select switch once and wait for the machine to reset, then toggle the MODE SET switch until the MSPIII panel reads 201. Disengage the idler arm on the wire drive so no wire will feed.

POWER MIG® 300



Return to Section TOC
 Return to Section TOC
 Return to Section TOC
 Return to Master TOC
 Return to Master TOC
 Return to Section TOC
 Return to Master TOC
 Return to Section TOC
 Return to Master TOC

TROUBLESHOOTING & REPAIR

TYPICAL OUTPUT VOLTAGE WAVEFORM - MACHINE LOADED

MACHINE LOADED TO 250 AMPS AT 26 VDC

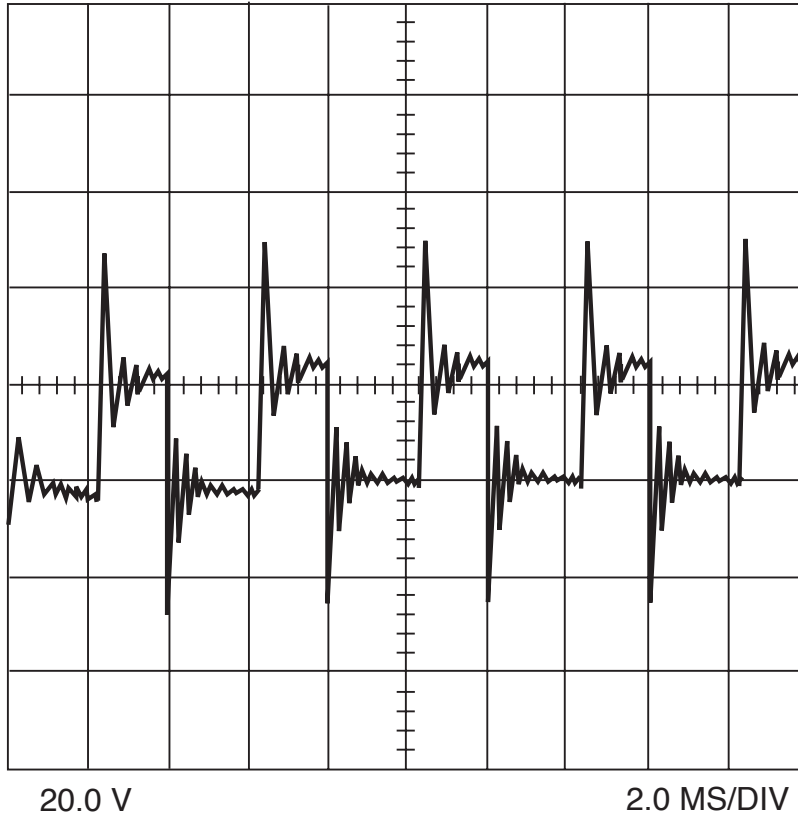

This is a typical DC output voltage waveform generated from a properly operating machine. Note that each vertical division represents 20 volts and that each horizontal division represents 2.00 milliseconds in time.

NOTE: Scope probes connected at the machine output terminals: (+) probe to electrode, (-) probe to work.

SCOPE SETTINGS

Volts/Div	20V/Div.
Horizontal Sweep	5 ms/Div.
Coupling.....	DC
Trigger	Internal

POWER MIG® 300



Return to Section TOC
Return to Master TOC

Return to Section TOC
Return to Master TOC

Return to Section TOC
Return to Master TOC

Return to Section TOC
Return to Master TOC

TROUBLESHOOTING & REPAIR

MOTOR & GEAR BOX ASSEMBLY REMOVAL AND REPLACEMENT



WARNING

Service and repair should be performed by only Lincoln Electric factory trained personnel. Unauthorized repairs performed on this equipment may result in danger to the technician or machine operator and will invalidate your factory warranty. For your safety and to avoid electrical shock, please observe all safety notes and precautions detailed throughout this manual.

If for any reason you do not understand the test procedures or are unable to perform the test/repairs safely, contact the Lincoln Electric Service Department for electrical troubleshooting assistance before you proceed. Call 1-888-935-3877.

DESCRIPTION

This test will aid the technician in the removal and replacement of the Motor and Gear box assembly.

MATERIALS NEEDED

- 3/8" Nut driver
- 5/16 in. Nut driver
- 9/16" Wrench
- 7/16" Wrench
- Small slot head screwdriver
- Large Phillips head screwdriver
- Pliers
- Wiring Diagram

POWER MIG® 300



TROUBLESHOOTING & REPAIR

MOTOR & GEAR BOX ASSEMBLY REMOVAL AND REPLACEMENT (*continued*)

REMOVAL PROCEDURE

WARNING

ELECTRIC SHOCK can kill.

High voltage is present when input power is applied to the machine.

1. Disconnect main input power to the machine.
2. Remove the wire gun and wire.
3. Lift the tool tray door to allow access to the tool tray.
4. Using the 5/16 in. nutdriver, remove the tool tray (3 screws) to gain access to the motor/gearbox assembly.
5. Disconnect motor leads 831 and 832 and tach leads 841, 844 and 847 at their in-line connectors. See the Wiring Diagram.
6. Using a 9/16 in. wrench, remove the bolt, lock washer, flat washer and positive lead from the wire drive assembly. Using pliers, remove the hose clamp and flex hose from the wire drive assembly. (Depends on the type of gun being used).
7. Rotate the adjustment arm assembly counterclockwise to release the tension on the idle arm.
8. Swing the idle arm up and away from the wire drive assembly.
9. Remove the outer guide assembly from the wire drive assembly by loosening the thumb screws until the outer guide can be removed. Rotate the molded keeper until the ears line up with the slots on the drive roll, then pull the drive roll off the shaft assembly. Now slide off the inner guide.

For Codes 10952 & Below, See *Figure F.11.*

10. Using a slotted screwdriver, remove the round head screw, lock washer, and flat washer securing the lower molded drive roll shaft assembly to the

wire drive assembly. Remove the molded drive roll shaft assembly from the wire drive assembly. It may be necessary to GENTLY pry behind the gear to get it started off the shaft.

11. Using a Phillips head screwdriver, remove the 3 pan head screws and lock washers securing the motor/gearbox assembly to the wire drive assembly.
12. Grasp the motor/gearbox assembly and wiggle it gently back and forth until it separates from the wire drive assembly.
13. Using a 5/16 in. nutdriver, remove the 3 screws holding the wire drive compartment (with wire drive assembly still attached) to the divider panel welded assembly. Pull the compartment away. The motor and gearbox can now be removed.
14. Using a 7/16 in. nutdriver, remove the 3 hex head cap screws, lock washers, and flat washers securing the wire drive assembly to the wire drive compartment.
15. Remove the wire drive assembly from the wire drive compartment.

For Codes 10958 & Above. See *Figure F.12.*

10. Using a 9/16 in. wrench to remove nut that holds molded drive roll shaft assembly to the wire drive assembly. Remove the molded drive roll shaft assembly from the wire drive assembly.
11. Using a 7/16 in. wrench remove panel covering the gear.
12. Using a Phillips head screwdriver remove gear.
13. Using a Phillips head screwdriver, remove the 3 pan head screws and lock washers securing the motor/gearbox assembly to the wire drive assembly.
14. Grasp the motor/gearbox assembly and wiggle it gently back and forth until it separates from the wire drive assembly.
15. Using a 3/8 nut driver remove 6 nuts that hold cover. Remove panel to expose drive motor.

TROUBLESHOOTING & REPAIR

MOTOR & GEAR BOX ASSEMBLY

REMOVAL AND REPLACEMENT *(continued)*

REPLACEMENT PROCEDURE

1. Bolt the wire drive assembly to the wire drive compartment.
2. Secure the wire drive compartment to the divider panel welded assembly.
3. Mount the motor/gearbox assembly to the wire drive assembly and attach with screws.
4. Assemble the drive roll components to the wire drive assembly.
5. Attach the flex hose and clamp.
6. Attach the tool tray.
7. Attach the wire gun and wire.

FIGURE F.11

FOR CODES BELOW 10952

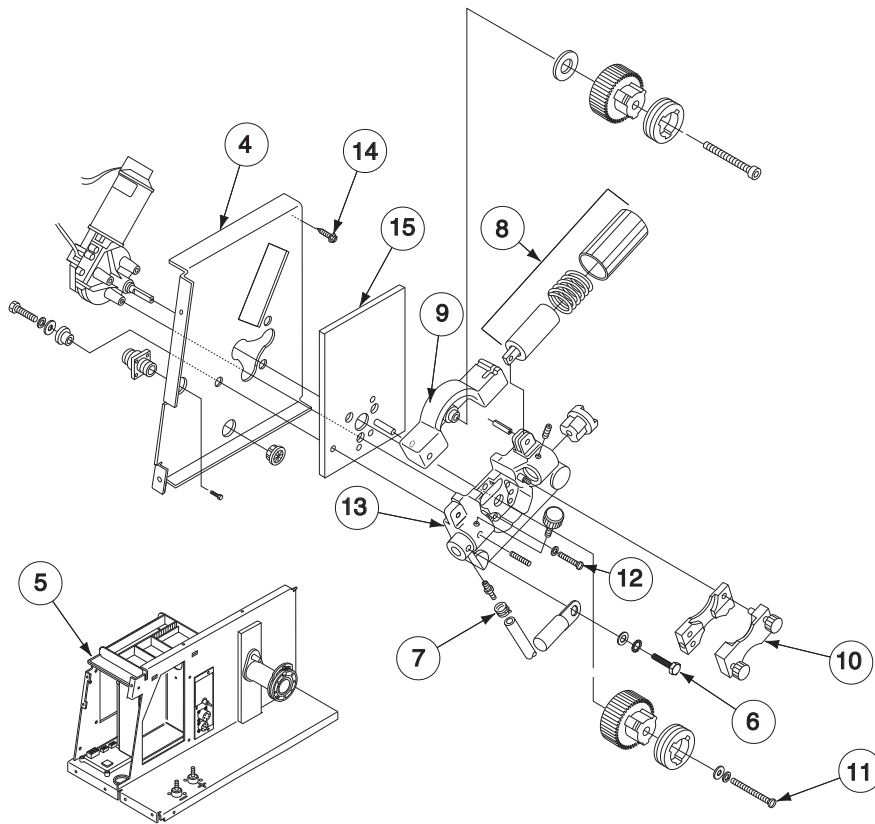

POWER MIG® 300



TROUBLESHOOTING & REPAIR

MOTOR & GEAR BOX ASSEMBLY REMOVAL AND REPLACEMENT *(continued)*

FIGURE F.12

FOR CODES ABOVE 10958

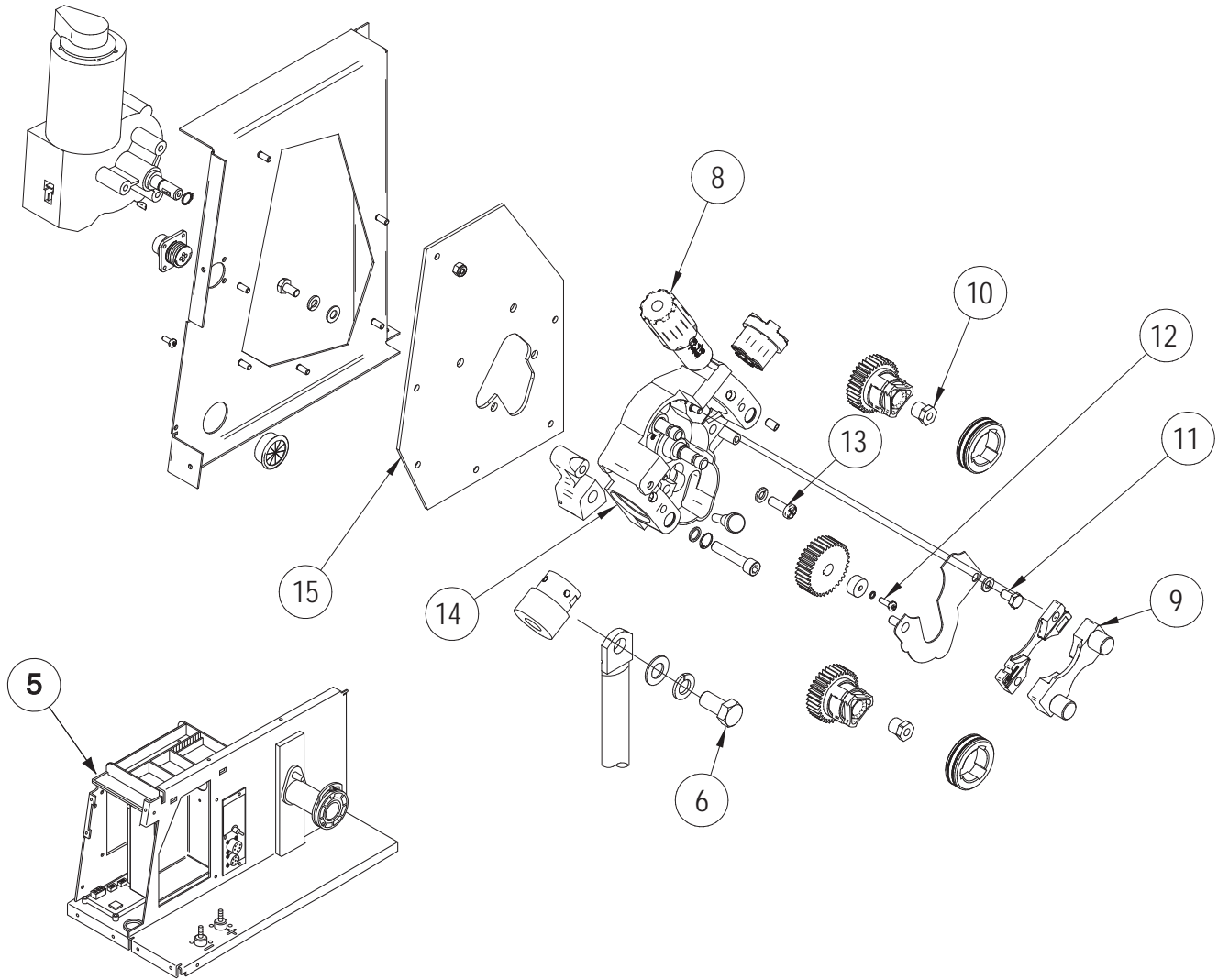

Return to Section TOC

Return to Section TOC

Return to Section TOC

Return to Section TOC

Return to Master TOC

Return to Master TOC

Return to Master TOC

Return to Master TOC

TROUBLESHOOTING & REPAIR

OUTPUT RECTIFIER REMOVAL AND REPLACEMENT



WARNING

Service and repair should be performed by only Lincoln Electric factory trained personnel. Unauthorized repairs performed on this equipment may result in danger to the technician or machine operator and will invalidate your factory warranty. For your safety and to avoid electrical shock, please observe all safety notes and precautions detailed throughout this manual.

If for any reason you do not understand the test procedures or are unable to perform the test/repairs safely, contact the Lincoln Electric Service Department for electrical troubleshooting assistance before you proceed. Call 1-888-935-3877.

DESCRIPTION

The procedure will aid the technician in the removal and replacement of the output rectifier assembly.

MATERIALS NEEDED

- 1/2 in. Open end wrench
- 1/2 in. Socket wrench and extension
- 3/8 in. Nutdriver
- 3/8 in. Open end wrench
- Slot head screwdriver
- Diagonal cutters
- Dow Corning #340 compound

POWER MIG® 300



TROUBLESHOOTING & REPAIR

OUTPUT RECTIFIER REMOVAL AND REPLACEMENT (continued)

FIGURE F.13

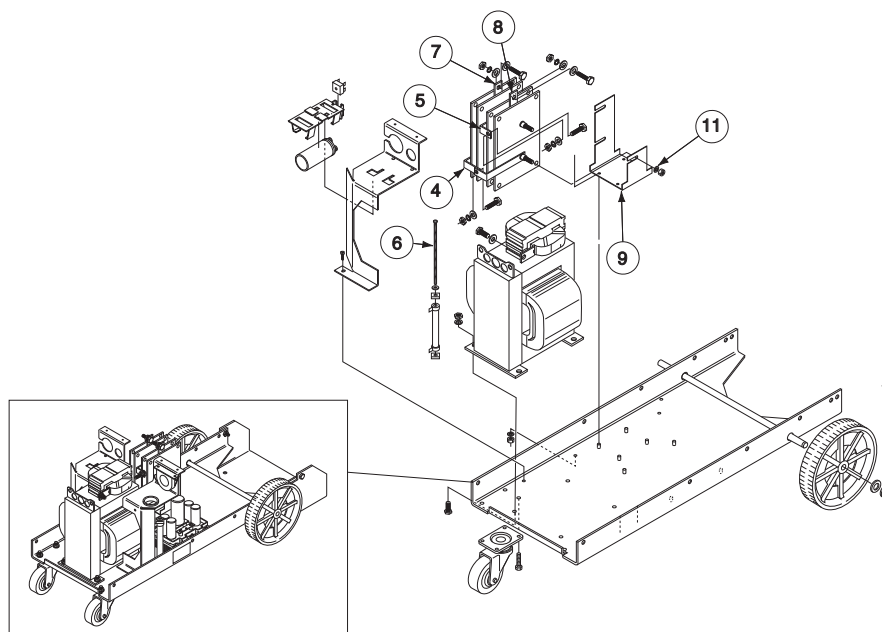

⚠ WARNING

ELECTRIC SHOCK can kill.

High voltage is present when input power is applied to the machine.

Note: Cut cable ties as needed to improve access.

See Figure F.13 for the following procedure.

1. Disconnect main input power from the machine.
2. Perform the **Chopper Board Capacitor Discharge Procedure**.
3. Remove the right side panel using a 3/8 in. nutdriver. (as viewed from the front of machine).
4. Using the 1/2 in. wrenches, remove heavy lead B1 and small resistor lead 2530 from the output rectifier lower terminal, marked negative (-). For reassembly, note placement of the fasteners: bolt, flat washer, heavy lead, small lead, terminal, flat washer, lock washer, nut.
5. Using the 1/2 in. wrenches, remove heavy lead B5 and small resistor lead 2520 from the output rectifier terminal marked positive (+). For reassembly, note placement of the fasteners: bolt, flat washer, heavy lead, small lead, terminal, flat washer, lock washer, nut.
6. Using a slot head screwdriver and a 3/8 in. wrench, remove Resistor R1 from the machine base. This will provide additional clearance for accessing fasteners and removing the rectifier. For reassembly, note order of the components for the resistor: screw, star washer, plastic insulator, resistor, plastic insulator. This assembly rests on top of the machine base. From beneath the base a flat washer, lock washer, and nut attach to the screw. It is a good practice to loosely assemble the parts and set the resistor aside until ready to be reassembled.
7. Using a 1/2 in. wrench and a 1/2 in. socket wrench with extension, remove heavy lead X2 from the terminal at the top of the rectifier, near side. For reassembly, note placement of the fasteners: bolt, flat washer, heavy lead, terminal, lock washer, nut.
8. Using a 1/2 in. wrench and a 1/2 in. socket wrench with extension, remove heavy lead X1 (from the output choke) from the other terminal at the top of the rectifier, nearer to the chopper board assembly. For reassembly, note placement of the fasteners: bolt, flat washer, heavy lead, terminal, lock washer, nut.
9. Using a 3/8 in. wrench, remove the 4 nuts and lock washers holding the rectifier bracket to the machine base.

POWER MIG® 300



TROUBLESHOOTING & REPAIR

OUTPUT RECTIFIER REMOVAL AND REPLACEMENT *(continued)*

10. Clear the leads and carefully remove the output rectifier assembly.
11. With a 1/2 in. wrench, loosen the 3 nuts holding the rectifier to its bracket.

REPLACEMENT PROCEDURE

NOTE: When installing the output rectifier assembly, apply a thin coating of Dow Corning #340 compound to the electrical connections.

1. Fit the new output rectifier into its bracket.
2. Install the output rectifier. Fasten it to the machine base with 4 lock washers and nuts.
3. Install heavy leads X1 and X2 to the terminals at the top of the output rectifier. X1 mounts to the terminal nearer to the chopper board assembly. Note placement of fasteners as described above.
4. Install resistor R1.
5. Install heavy lead B5 and resistor lead 2520 to the lower terminal, marked (+).
6. Install heavy lead B1 and resistor lead 2530 to the upper terminal, marked (-).
7. Replace any cable ties removed for disassembly.
8. Install the case side panels.

TROUBLESHOOTING & REPAIR

CHOPPER BOARD ASSEMBLY REMOVAL AND REPLACEMENT



WARNING

Service and repair should be performed by only Lincoln Electric factory trained personnel. Unauthorized repairs performed on this equipment may result in danger to the technician or machine operator and will invalidate your factory warranty. For your safety and to avoid electrical shock, please observe all safety notes and precautions detailed throughout this manual.

If for any reason you do not understand the test procedures or are unable to perform the test/repairs safely, contact the Lincoln Electric Service Department for electrical troubleshooting assistance before you proceed. Call 1-888-935-3877.

DESCRIPTION

The following procedure will aid the technician in the removal and replacement of the Chopper Board assembly. The assembly is replaced as a unit; there are no serviceable parts.

MATERIALS NEEDED

- 5/16 in. Nutdriver
- 3/8 in. Nutdriver or wrench
- 7/16 in. Open end wrench
- 1/2 in. Open end wrench
- 1/2 in. Socket wrench, universal tool, and extension
- 3/8 in. Nutdriver
- 3/8 in. Open end wrench
- Diagonal cutters
- Wiring Diagram

POWER MIG® 300



TROUBLESHOOTING & REPAIR

CHOPPER BOARD ASSEMBLY REMOVAL AND REPLACEMENT *(continued)*

FIGURE F.14 – CHOPPER BOARD ASSEMBLY DETAILS

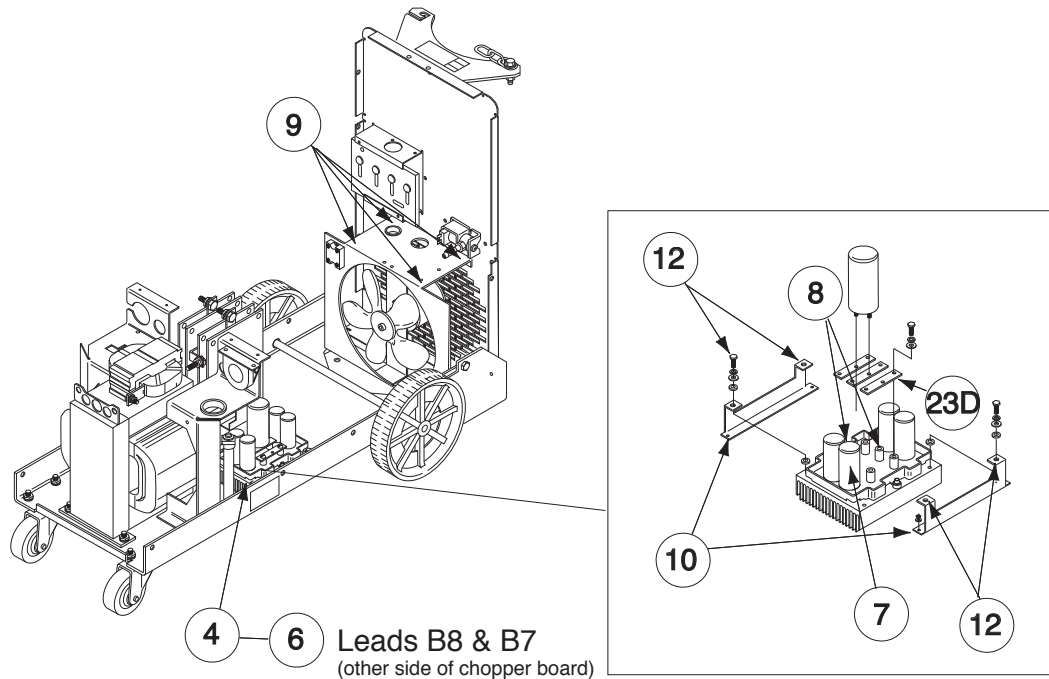

REMOVAL PROCEDURE

⚠ WARNING

ELECTRIC SHOCK can kill.

High voltage is present when input power is applied to the machine.

Note: Cut cable ties as needed to improve access.

See Figure F.14 for the following procedure.

1. Disconnect main input power from the machine.
2. Perform the **Chopper Board Capacitor Discharge Procedure**.
3. Remove the case side panels using a 3/8 in. nut-driver.
4. Label and disconnect thermostat leads 503 and 503A.
5. Unplug J99 from the chopper board.
6. Disconnect lead 607 from terminal B8 and lead 613 from terminal B7 at their in-line connectors.
7. Using a 7/16 in. wrench, remove heavy lead B8 (to negative output terminal) and B2 (to choke) from the chopper board.
8. Using a 7/16 in. wrench, remove heavy leads B1 and B5 (to output rectifier) from the chopper board.
9. Using the 5/16 in. nutdriver, remove the 4 screws holding the fan baffle to the machine base. This will allow you to move the baffle back out of the way to access the right rear nut on the chopper assembly bracket.
10. Using the 3/8 in. wrench or nutdriver, remove the 4 nuts holding the chopper assembly brackets to the machine base.
11. Carefully remove the chopper assembly from the machine.
12. Using a 7/16 in. wrench, remove the 2 support brackets from the chopper board assembly.

POWER MIG® 300



TROUBLESHOOTING & REPAIR

CHOPPER BOARD ASSEMBLY REMOVAL AND REPLACEMENT *(continued)*

REPLACEMENT PROCEDURE

1. Attach the chopper assembly brackets to the new chopper assembly.
2. Install the chopper board assembly. Fasten it to the machine base with 4 lock washers and nuts.
3. Install heavy leads B1 and B5.
4. Install heavy leads B6 and B2.
5. Connect lead 607 (B8) and lead 613 (B7) at their in-line connectors.
6. Connect plug J99.
7. Connect thermostat leads 503 and 503A.
8. Install the case side panels.

POWER MIG® 300



Return to Section TOC
Return to Master TOC

Return to Section TOC
Return to Master TOC

Return to Section TOC
Return to Master TOC

Return to Section TOC
Return to Master TOC

TROUBLESHOOTING & REPAIR

MAIN TRANSFORMER AND OUTPUT CHOKE REMOVAL AND REPLACEMENT



WARNING

Service and repair should be performed by only Lincoln Electric factory trained personnel. Unauthorized repairs performed on this equipment may result in danger to the technician or machine operator and will invalidate your factory warranty. For your safety and to avoid electrical shock, please observe all safety notes and precautions detailed throughout this manual.

If for any reason you do not understand the test procedures or are unable to perform the test/repairs safely, contact the Lincoln Electric Service Department for electrical troubleshooting assistance before you proceed. Call 1-888-935-3877.

DESCRIPTION

The procedure will aid the technician in the removal and replacement of the main transformer and choke assembly.

MATERIALS NEEDED

- 5/16 in. Nutdriver
- 3/8 in. Nutdriver or open end wrench
- 1/2 in. Open end wrench
- 1/2 in. Socket wrench and extension
- 9/16 in. Open end wrench
- Diagonal cutters
- Phillips head screwdriver

POWER MIG® 300



Return to Section TOC

Return to Master TOC

Return to Section TOC

Return to Master TOC

Return to Section TOC

Return to Master TOC

Return to Section TOC

Return to Master TOC

TROUBLESHOOTING & REPAIR

MAIN TRANSFORMER AND OUTPUT CHOKE REMOVAL AND REPLACEMENT *(continued)*

REMOVAL PROCEDURE

WARNING

ELECTRIC SHOCK can kill.

High voltage is present when input power is applied to the machine.

Note: Cut cable ties as needed to improve access.

PREPARATION

1. Disconnect main input power from the machine.
2. Remove the case side panels using a 3/8 in. nutdriver.
3. Perform the **Chopper Board Capacitor Discharge Procedure**.
4. Remove the case top using a 3/8 in. nutdriver.

5. Remove gun.
6. Remove work lead from output stud.

CASE FRONT ASSEMBLY REMOVAL

7. Remove the case front assembly as follows:
 - a. Using a phillips head screwdriver, remove the 2 screws holding the line switch to the case front.
 - b. Using a 5/16 in. nutdriver, remove 10 screws holding the case front to the machine base and center assembly.
 - c. Lift the case front upward and forward slightly, then disconnect plug J34 from the MSP3 mode select panel. The case front assembly can now be removed. **See Figure F.13.**

POWER MIG® 300



TROUBLESHOOTING & REPAIR

MAIN TRANSFORMER AND OUTPUT CHOKE REMOVAL AND REPLACEMENT *(continued)*

LEAD DISCONNECTION

8. Using a phillips head screwdriver, remove fan lead X4 from fan relay terminal #1 and disconnect fan lead X3 from its in-line connector at the fan motor. Cut cable ties as needed pull the leads through the baffles to clear them.
9. Using a 1/2 in. wrench, disconnect leads X1 and X2 from the output rectifier. Note the order of the fasteners for reassembly: bolt, flat washer, heavy lead, terminal, lock washer, nut.
10. Disconnect leads X5 and X6 from the control rectifier (spade connectors).
11. Disconnect thermostat leads 502 and 503A from their in-line connectors (right side of the machine).
12. Using a 3/8 in. nutdriver, disconnect leads H2, H3, and H5 from the reconnect panel terminals 2, 3, and 5.
13. Using a 3/8 in. driver, disconnect leads H1 and H4 from the back of the line switch. Looking at the back of the switch, H1 is at the bottom right and H4 is at the bottom left. Note that leads H1 and H4, which go to the reconnect panel, attach at these same terminals.
14. Using a 1/2 in. wrench and socket wrench, disconnect heavy lead B2 from the choke.
15. Using a 9/16 in. wrench and socket wrench, disconnect the heavy lead from the choke to the positive output terminal. It is not necessary to remove any other leads; screw the bolt with leads still attached back into the positive output terminal until reassembly.

MAIN TRANSFORMER AND CHOKE ASSEMBLY REMOVAL

16. Using a 1/2 in. socket wrench, remove 4 nuts and lock washers that hold the main transformer to the machine base. Also remove the 4 in. bolts from underneath.
17. Using a 5/16 in. nutdriver, remove the 2 screws that hold the right and left transformer baffle in place (1 screw each). The center assembly and

rear assembly can now be lifted enough to allow the main transformer and choke assembly to be removed.

18. With the help of an assistant, lift the front of the center assembly and slide the main transformer and choke assembly out through the front of the machine. Use care -- the assembly is very heavy.

REPLACEMENT PROCEDURE

For lead reassembly steps, also see the Wiring Diagram.

1. With the help of an assistant, carefully slide the new transformer/choke assembly into place. Attach it to the machine base with 4 bolts, lock washers, and nuts.
2. Attach the right and left transformer baffles to the machine base (1 screw each side).
3. Connect the heavy lead from the top of the choke to the positive output terminal.
4. Connect heavy lead B2 to the choke.
5. Connect leads H1 and H4 to the back of the line switch. See disassembly step for details.
6. Connect leads H2, H3, and H5 to the reconnect panel.
7. Connect thermostat leads 502 and 503A at their in-line connectors (right side of the machine).
8. Connect leads X5 and X6 to the control rectifier (spade connectors).
9. Connect leads X1 and X2 to the output rectifier. Note the order of the fasteners: bolt, flat washer, heavy lead, terminal, lock washer, nut.
10. Connect fan lead X4 to fan relay terminal 1 and fan lead X3 at its in line connector at the fan motor.
11. Install the case front assembly. Connect plug J34 and mount the line switch.
12. Install new cable ties as needed.

POWER MIG® 300



TROUBLESHOOTING & REPAIR

MAIN TRANSFORMER AND OUTPUT CHOKE REMOVAL AND REPLACEMENT (continued)

FIGURE F.15

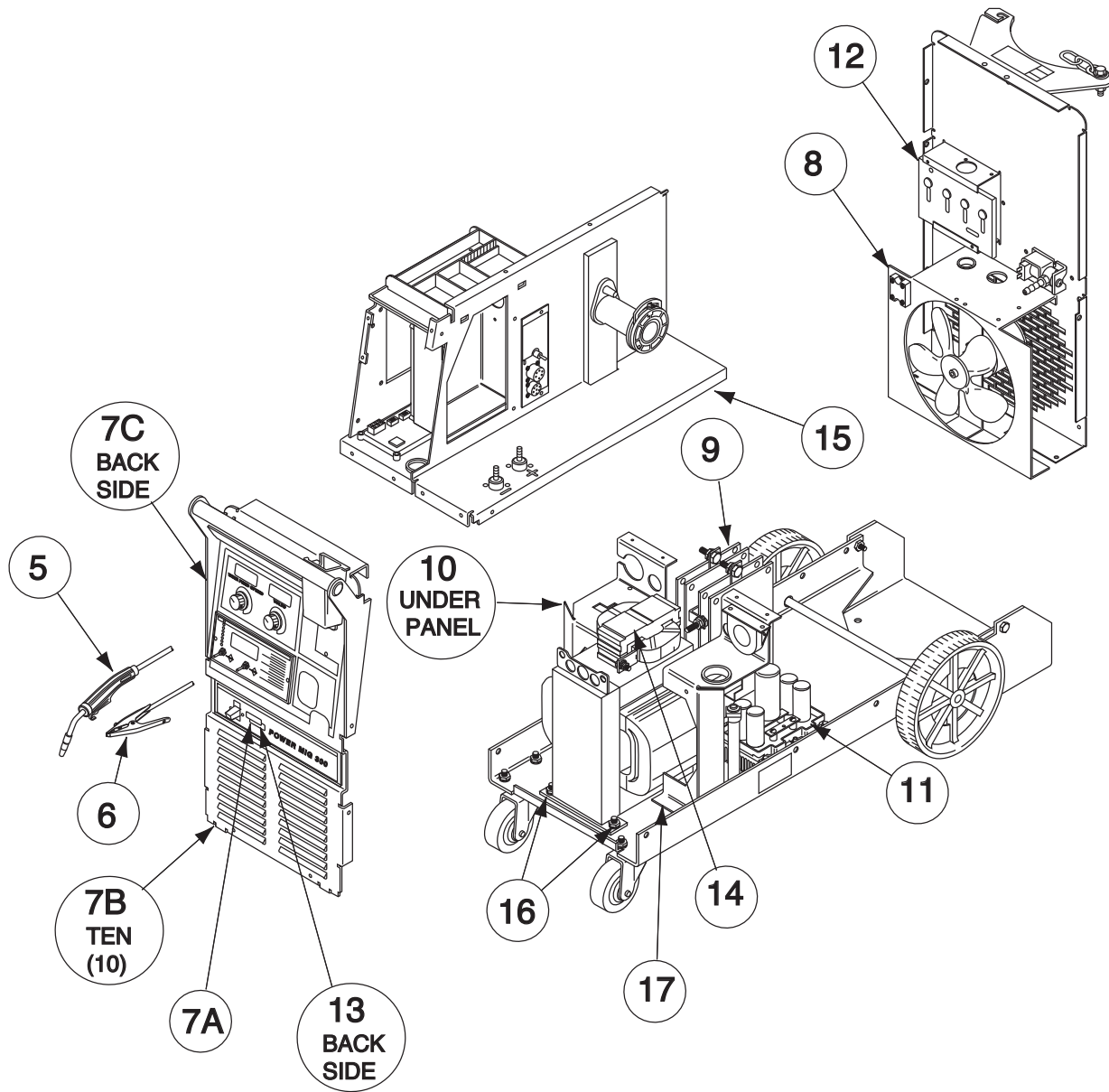

POWER MIG® 300



Return to Section TOC

Return to Section TOC

Return to Section TOC

Return to Section TOC

Return to Master TOC

Return to Master TOC

Return to Master TOC

Return to Master TOC

TROUBLESHOOTING & REPAIR

FAN MOTOR ASSEMBLY REMOVAL AND REPLACEMENT



WARNING

Service and repair should be performed by only Lincoln Electric factory trained personnel. Unauthorized repairs performed on this equipment may result in danger to the technician or machine operator and will invalidate your factory warranty. For your safety and to avoid electrical shock, please observe all safety notes and precautions detailed throughout this manual.

If for any reason you do not understand the test procedures or are unable to perform the test/repairs safely, contact the Lincoln Electric Service Department for electrical troubleshooting assistance before you proceed. Call 1-888-935-3877.

DESCRIPTION

The procedure will aid the technician in the removal and replacement of the fan motor assembly.

MATERIALS NEEDED

- 3/8 in. Nutdriver
- 11/32 in. Open end wrench
- Diagonal cutters
- Slot or phillips head screwdriver

TROUBLESHOOTING & REPAIR

FAN MOTOR ASSEMBLY REMOVAL AND REPLACEMENT

(continued)

FIGURE F.16 – FAN MOTOR ASSEMBLY REMOVAL

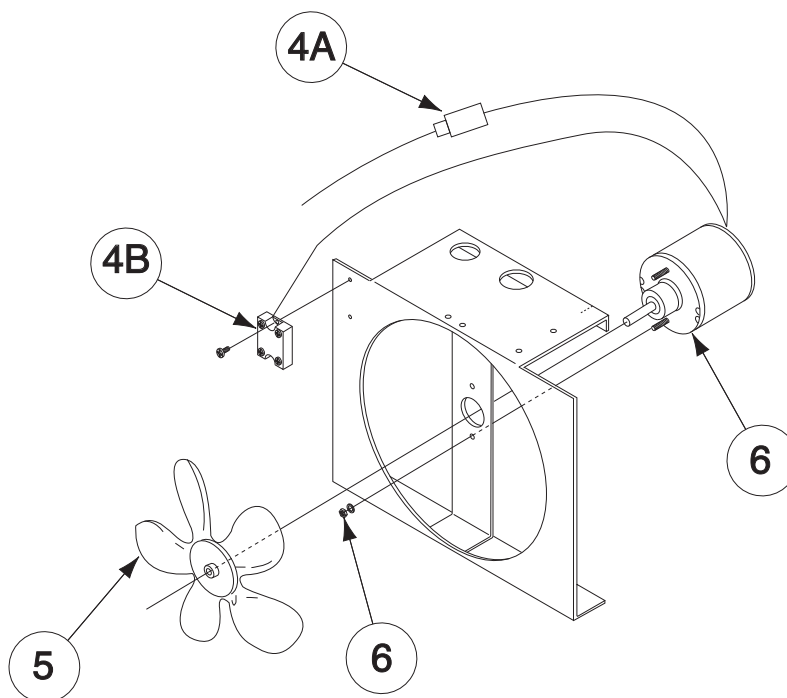

REMOVAL PROCEDURE

1. Disconnect main input power to the machine.
2. Remove the case side panels using a 3/8 in. nut-driver.
3. Cut the wire tie from around the fan motor leads.
4. Disconnect fan motor leads:
 - a. Unplug the black lead from its in-line connector.
 - b. Using a slot or phillips head screw driver, disconnect the white lead at the fan relay. See Figure F.16.
5. Remove the fan blade. Note the position of the fan on the shaft for reassembly.
 - a. Using a slot head screwdriver, loosen the fan blade clamp.
 - b. Slide the fan blade off the motor shaft.

6. Remove the fan motor.
 - a. Loosen and remove the two nuts and lock washers from the motor mounting bracket using a 11/32 in. open end wrench.
 - b. When the motor is free from the mounting bracket, slide the motor from the POWER MIG® unit.

REPLACEMENT PROCEDURE

1. Attach the fan motor to the mounting bracket.
2. Install the fan blade and tighten the fan blade clamp. Ensure the fan is in the same position on the shaft as it was prior to removal. Spin the fan to be sure it is free to rotate.
3. Connect the fan motor leads: black at its in-line connector and white at fan relay terminal 1.
4. Install the case sides.

POWER MIG® 300



TROUBLESHOOTING & REPAIR

VOLTAGE & CURRENT CALIBRATION PROCEDURE



WARNING

Service and repair should be performed by only Lincoln Electric factory trained personnel. Unauthorized repairs performed on this equipment may result in danger to the technician or machine operator and will invalidate your factory warranty. For your safety and to avoid electrical shock, please observe all safety notes and precautions detailed throughout this manual.

If for any reason you do not understand the test procedures or are unable to perform the test/repairs safely, contact the Lincoln Electric Service Department for electrical troubleshooting assistance before you proceed. Call 1-888-935-3877.

DESCRIPTION

This test will determine if the machine is capable of producing welding output as well as check and adjust, if necessary, the voltage and or current calibration.

MATERIALS NEEDED

- Resistive Load Bank
- Calibrated Test Voltmeter
- Calibrated Test Ammeter

POWER MIG® 300



TROUBLESHOOTING & REPAIR

VOLTAGE & CURRENT CALIBRATION PROCEDURE (*continued*)

CALIBRATION CHECK (CODE 10562)

The calibration of the POWER MIG® 300 can be checked using a resistive load bank with the POWER MIG® 300 in mode 200. Mode 200 is a constant current test mode.

1. Toggle and hold the mode select switch in the up position.
2. Turn on the POWER MIG® 300.
3. Rotate the output knob, while still holding the mode select switch up, until the display reads "ALL nodE".
4. Release the mode select switch, toggle the mode switch one more time, then toggle the MODE SET switch until the MSPIII panel reads 200. Disengage the idler arm on the wire drive so no wire will feed.
5. With the machine in mode 200 apply a resistive to the welding output terminals (approx. .106 ohms) set the machine output to 250 amps and enable the weld terminals by pressing the trigger switch.
6. Using the test meters note the output voltage and current.
7. The POWER MIG® 300 voltmeter must match the test meter reading to within +/- 1 volt.
8. The POWER MIG® 300 ammeter must match the test meter within +/- 5 amps.
9. If the volt meter does not meet the specification then proceed to the **Voltage Calibration Procedure**.
10. If the ammeter does not meet the specification then proceed to the **Current Calibration Procedure**.

NOTE: Before attempting to calibrate the voltage or current setting of the POWER MIG®, be sure to read the entire voltage or current calibration procedure. If the steps are not completed quickly, the machine will automatically leave the calibration mode without changing the calibration settings. The voltage and current calibration settings of the POWER MIG® are completely independent of each other. Adjusting one will not affect the other.

VOLTAGE CALIBRATION

1. Connect the resistive load bank (approximately .106 ohms or 250 amps) and test voltmeter to the welding output terminals.
2. Toggle and hold in the mode select switch in the up position.
3. Turn on the POWER MIG® 300.
4. Rotate the right hand output control knob until the display reads "vol cAL".
5. Release the mode select switch.
6. The left display will change to "VcAL" to indicate that voltage calibration is in progress.
7. The right hand display will scroll the following message: Adj rEnc SorEAL vol = 20V.
8. Adjust output control knob until the actual output voltage reading on the test volt meter is 20 volts +/- .5 volts.

POWER MIG® 300



TROUBLESHOOTING & REPAIR

VOLTAGE & CURRENT CALIBRATION PROCEDURE (*continued*)

9. Wait for the machine's output to be automatically turned off and then back on.
10. Adjust the output control knob again if necessary to make the actual voltage output 20 volts +/- .5 volts.
11. Wait for the machine's output to be automatically turned off and then back on.
12. Repeat the above two steps if necessary.
13. Toggle the mode select switch up and release the switch to save the calibration setting.
14. The right display will display the message "VcAL SAVEd". Within 5 seconds, hold the mode set switch in the up position until the right display stops blinking.
15. The machine will reset to normal operation after a few seconds.

NOTE: If the mode select switch is not toggled within 30 seconds after adjusting the output control knob, the machine will leave the calibration mode and use the previous calibration settings.

CURRENT CALIBRATION PROCEDURE

1. Connect the resistive load bank of approx. .106 ohms and test ammeter to the welding output terminals.
2. Toggle and hold the mode select button in the up position.
3. Turn on the POWER MIG® 300.
4. Rotate the output control knob until the display reads "cur cAL".

5. Release the mode select switch.
6. The left display will change to "lcAL" to indicate that current calibration is in progress.
7. The right hand display will scroll the following message: Adj rEnc SorEAL cur = 250A.
8. Adjust the right hand output control knob until the actual output current reading on the test ammeter is 250 amps +/- 2A.
9. Wait for the machine's output to be automatically turned off and then back on.
10. Adjust the output control knob again if necessary to make the actual output current reading on the test ammeter 250 amps +/- 2A.
11. Wait for the machine's output to be automatically turned off and then back on.
12. Repeat the above two steps if necessary.
13. Toggle the mode select switch up and release the switch to save the calibration setting.
14. The right display will display the message "lcAL SAVEd". Within 5 seconds, hold the mode set switch in the up position until the right display stops blinking.
15. The machine will reset to normal operation after a few seconds.

NOTE: If the mode select switch is not toggled within 30 seconds after adjusting the output control knob, the machine will leave the calibration mode and use the previous calibration settings.

POWER MIG® 300



TROUBLESHOOTING & REPAIR

VOLTAGE & CURRENT CALIBRATION PROCEDURE (*continued*)

CALIBRATION CHECK (CODES 10952 AND UP)

The calibration of the POWER MIG® 300 can be checked using a resistive load bank with the POWER MIG® 300 in mode 200. Mode 200 is a constant current test mode.

1. Toggle and hold the mode select switch in the up position.
2. Turn on the POWER MIG® 300.
3. Once the display reads “Pres Spin” release the mode select switch. Rotate the output knob until the display reads “ALL nodE”.
4. Toggle the Mode Select switch once and wait for the machine to reset, then toggle the MODE SET switch until the MSPIII panel reads 200. Disengage the idler arm on the wire drive so no wire will feed.
5. With the machine in mode 200 apply a resistive to the welding output terminals (approx. .106 ohms) set the machine output to 250 amps and enable the weld terminals by pressing the trigger switch.
6. Using the test meters note the output voltage and current.
7. The POWER MIG® 300 voltmeter must match the test meter reading to within +/- 1 volt.
8. The POWER MIG® 300 ammeter must match the test meter within +/- 5 amps.
9. If the volt meter does not meet the specification then proceed to the **Voltage Calibration Procedure**.
10. If the ammeter does not meet the specification then proceed to the **Current Calibration Procedure**.

NOTE: Before attempting to calibrate the voltage or current setting of the POWER MIG®, be sure to read the entire voltage or current calibration procedure. If the steps are not completed quickly, the machine will automatically leave the calibration mode without changing the calibration settings. The voltage and current calibration settings of the POWER MIG® are completely independent of each other. Adjusting one will not affect the other.

VOLTAGE CALIBRATION

1. Connect the resistive load bank (approximately .106 ohms) and test voltmeter to the welding output terminals.
2. Toggle and hold in the mode select switch in the up position.
3. Turn on the POWER MIG® 300.
4. Once the display reads “Pres Spin” release the mode select switch. Rotate the output knob until the display reads “vol cAL”.
5. Release the mode select switch once.
6. The left display will change to “VcAL” to indicate that voltage calibration is in progress.
7. The right hand display will scroll the following message: Adj rEnc SorEAL vol = 20V.
8. Adjust output control knob until the actual output voltage reading on the test volt meter is 20 volts +/- .5 volts.

POWER MIG® 300



TROUBLESHOOTING & REPAIR

VOLTAGE & CURRENT CALIBRATION PROCEDURE (*continued*)

9. Wait for the machine's output to be automatically turned off and then back on.
10. Adjust the output control knob again if necessary to make the actual voltage output 20 volts +/- .5 volts.
11. Wait for the machine's output to be automatically turned off and then back on.
12. Repeat the above two steps if necessary.
13. Toggle the mode select switch up and release the switch to save the calibration setting.
14. The right display will display the message "VcAL SAVEd". Within 5 seconds, hold the mode set switch in the up position until the right display stops blinking.
15. The machine will reset to normal operation after a few seconds.

NOTE: If the mode select switch is not toggled within 30 seconds after adjusting the output control knob, the machine will leave the calibration mode and use the previous calibration settings.

CURRENT CALIBRATION PROCEDURE

1. Connect the resistive load bank of approx. .106 ohms and test ammeter to the welding output terminals.
2. Toggle and hold the mode select button in the up position.
3. Turn on the POWER MIG® 300.
4. Once the display reads "Pres Spin" release the mode select switch. Rotate the output

- knob until the display reads "cur cAL".
5. Toggle the Mode Select switch once.
6. The left display will change to "lcAL" to indicate that current calibration is in progress.
7. The right hand display will scroll the following message: Adj rEnc SorEAL cur = 250A.
8. Adjust the right hand output control knob until the actual output current reading on the test ammeter is 250 amps +/- 2A.
9. Wait for the machine's output to be automatically turned off and then back on.
10. Adjust the output control knob again if necessary to make the actual output current reading on the test ammeter 250 amps +/- 2A.
11. Wait for the machine's output to be automatically turned off and then back on.
12. Repeat the above two steps if necessary.
13. Toggle the mode select switch up and release the switch to save the calibration setting.
14. The right display will display the message "lcAL SAVEd". Within 5 seconds, hold the mode set switch in the up position until the right display stops blinking.
15. The machine will reset to normal operation after a few seconds.

NOTE: If the mode select switch is not toggled within 30 seconds after adjusting the output control knob, the machine will leave the calibration mode and use the previous calibration settings.

POWER MIG® 300



TROUBLESHOOTING & REPAIR

RETEST AFTER REPAIR

Retest a machine:

- If it is rejected under test for any reason that requires you to remove any part which could affect the machine's electrical characteristics.

OR

- If you repair or replace any electrical components.

TEST MODE
5

INPUT IDLE WATTS AND AMPS

Input Volts/Hertz	Maximum Idle Watts	Maximum Idle Amps
230/60	400	4.25

OPEN CIRCUIT VOLTAGE

45-49 VDC

WIRE SPEED RANGE

50 - 700 IPM (1.27 - 17.8 m/minute)

OUTPUT

AMPS	VOLTS
200A	27-30

POWER MIG® 300



NOTES

Return to Section TOC
Return to Master TOC

Return to Section TOC
Return to Master TOC

Return to Section TOC
Return to Master TOC

Return to Section TOC
Return to Master TOC

POWER MIG® 300

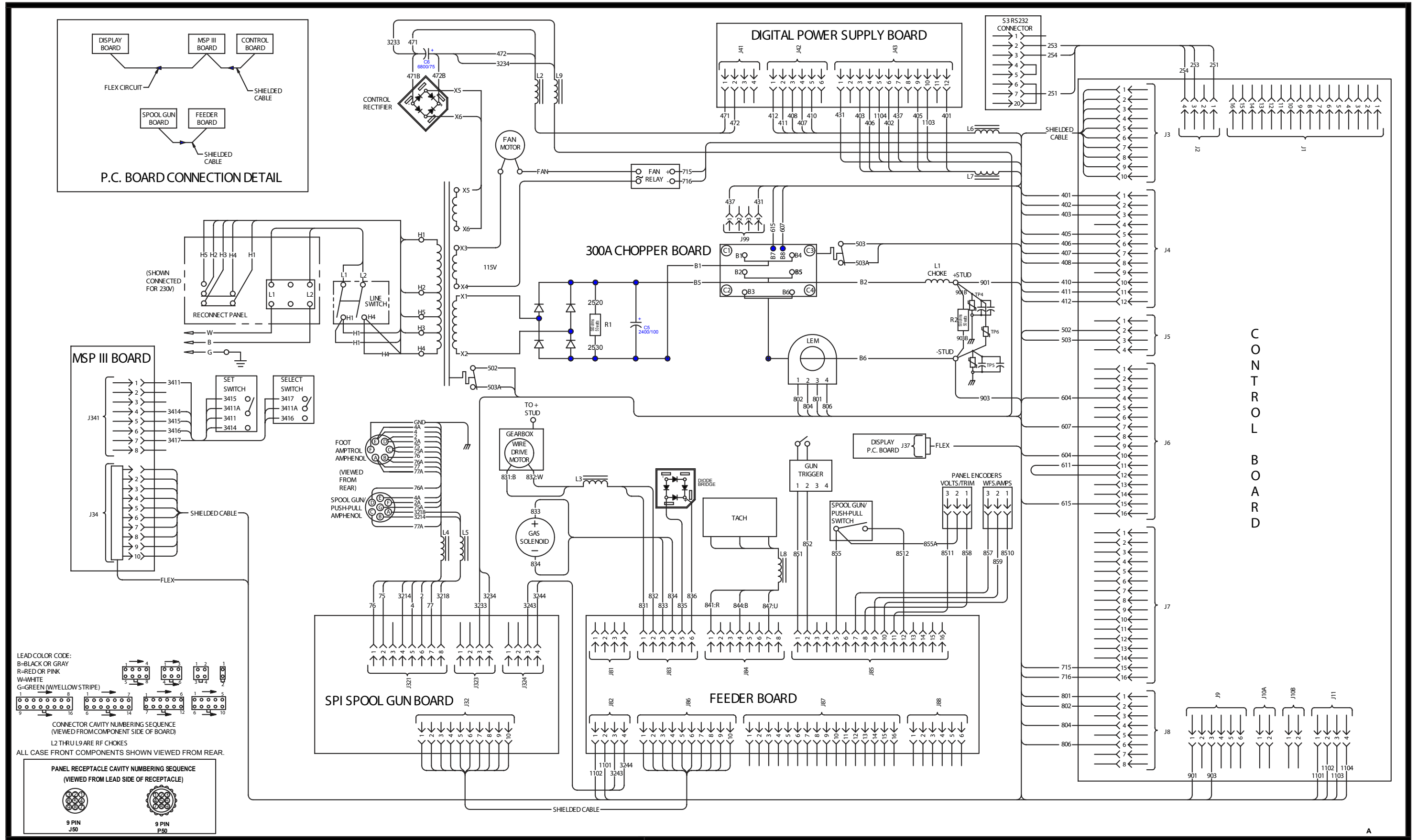

TABLE OF CONTENTS -ELECTRICAL DIAGRAMS SECTION-

ELECTRICAL DIAGRAMS	SECTION G
WIRING DIAGRAM (CODE 10562 ONLY-G3852)	G-2
WIRING DIAGRAM (CODE 10952 ONLY-G4068)	G-3
WIRING DIAGRAM (CODE 10958 AND 11000 ONLY-G4305).....	G-4
WIRING DIAGRAM (CODE 11097 AND 11098 ONLY-G4511).....	G-5
ENTIRE MACHINE SCHEMATIC (CODE 10958 and 11000 ONLY-G4315).....	G-6
ENTIRE MACHINE SCHEMATIC (CODE 11097 and 11098 ONLY-G4512).....	G-7
CONTROL PC BOARD SCHEMATIC #1 (CODE 10562 - 11098 - G3789-1D0/1)	G-8
CONTROL PC BOARD SCHEMATIC #2 (CODE 10562 - 11098 - G3789-1D0/2)	G-9
CONTROL PC BOARD SCHEMATIC #3 (CODE 10562 - 11098 - G3789-1D0/3)	G-10
CONTROL PC BOARD SCHEMATIC #4 (CODE 10562 - 11098 - G3789-1D0/4)	G-11
CONTROL PC BOARD ASSEMBLY (CODE 10562 - 11098 - L11088-1).....	*
POWER SUPPLY PC BOARD SCHEMATIC (CODE 10562 - 11098 - G3631)	G-12
POWER SUPPLY PC BOARD ASSEMBLY (CODE 10562 - 11098 - G3632-2).....	*
CHOPPER PC BOARD SCHEMATIC (CODE 10562 - 11098 - M20046-1L2)	G-13
CHOPPER PC BOARD ASSEMBLY (CODE 10562 - 11098 - L11497-1).....	*
MSP3 PC BOARD SCHEMATIC (CODE 10562 - 11098 - L11612)	G-14
MSP3 PC BOARD ASSEMBLY(CODE 10562 - 11098 - M19790-1).....	G-15
FEEDER PC BOARD SCHEMATIC (CODE 10562 - 11098 - G3883 - SHEET 1)	G-16
FEEDER PC BOARD SCHEMATIC (CODE 10562 - 11098 - G3883 - SHEET 2)	G-17
FEEDER PC BOARD ASSEMBLY (CODE 10562 - 11098 - G3884)	*
SPOOL GUN PC BOARD SCHEMATIC (CODE 10562 - 11098 - G3997 - SHEET 1)	G-18
SPOOL GUN PC BOARD SCHEMATIC (CODE 10562 - 11098 - G3997 - SHEET 2)	G-19
SPOOL GUN PC BOARD ASSEMBLY (CODE 10562 - 11098 - M20159-1)	*
ENCODER PC BOARD SCHEMATIC (CODE 10562 ONLY - L11558)	G-20
ENCODER PC BOARD ASSEMBLY (CODE 10562 ONLY - L11559-2).....	G-21
DISPLAY PC BOARD SCHEMATIC (CODE 10562 - 11098 - L11108).....	G-22
DISPLAY PC BOARD ASSEMBLY (CODE 10562 - 11098 - L11757-1).....	G-23

* NOTE: Many PC Board Assemblies are now totally encapsulated and are therefore considered to be unserviceable. The Assembly numbers are provided on this page but the actual drawings are no longer included.

WIRING DIAGRAM - POWER MIG 300 CODE 10952 ONLY



NOTE: This diagram is for reference only. It may not be accurate for all machines covered by this manual. The wiring diagram specific to your code is pasted inside one of the enclosure panels of your machine.

Return to Section TOC
Return to Master TOC

Return to Section TOC
Return to Master TOC

Return to Section TOC
Return to Master TOC

Return to Section TOC
Return to Master TOC

WIRING DIAGRAM - POWER MIG 300 CODE 11097 AND 11098 ONLY

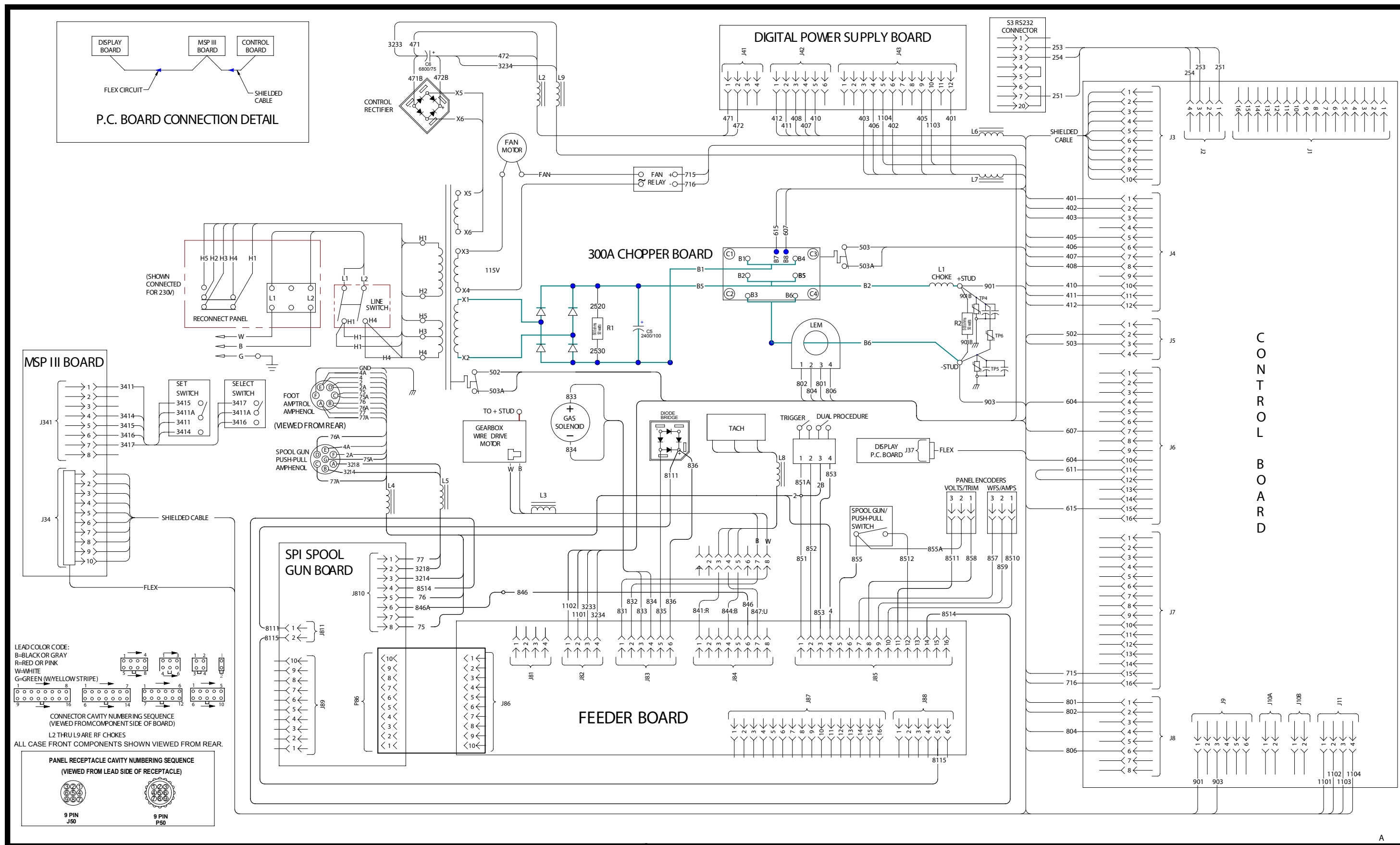

NOTE: This diagram is for reference only. It may not be accurate for all machines covered by this manual. The wiring diagram specific to your code is pasted inside one of the enclosure panels of your machine.

SCHEMATIC - COMPLETE MACHINE - CODE 10958 AND 11000 ONLY

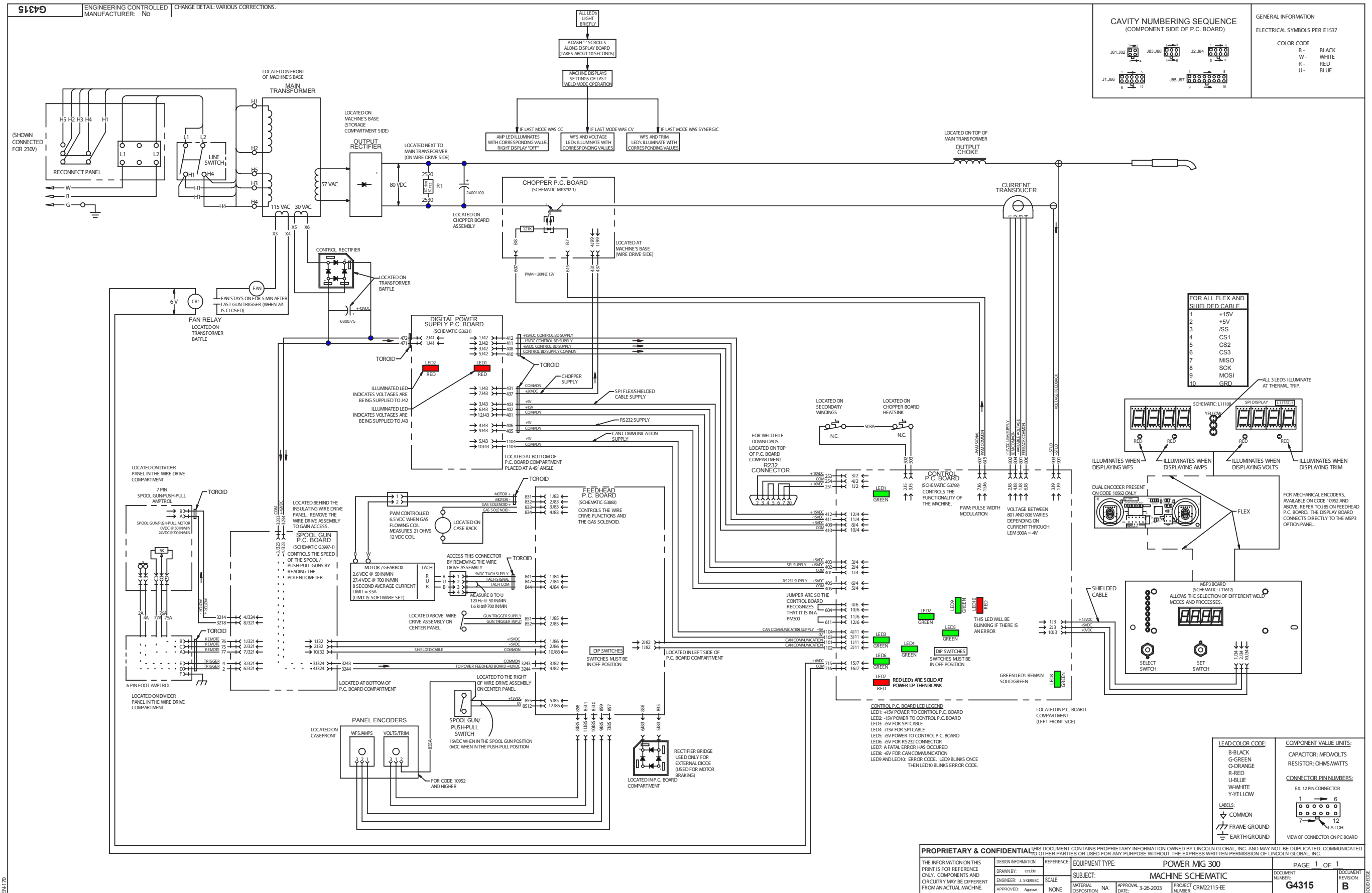

NOTE: This diagram is for reference only. It may not be accurate for all machines covered by this manual.

Return to Section TOC
Return to Section TOC
Return to Section TOC
Return to Section TOC
Return to Section TOC
Return to Section TOC

SCHEMATIC - COMPLETE MACHINE - CODE 11097 AND 11098 ONLY

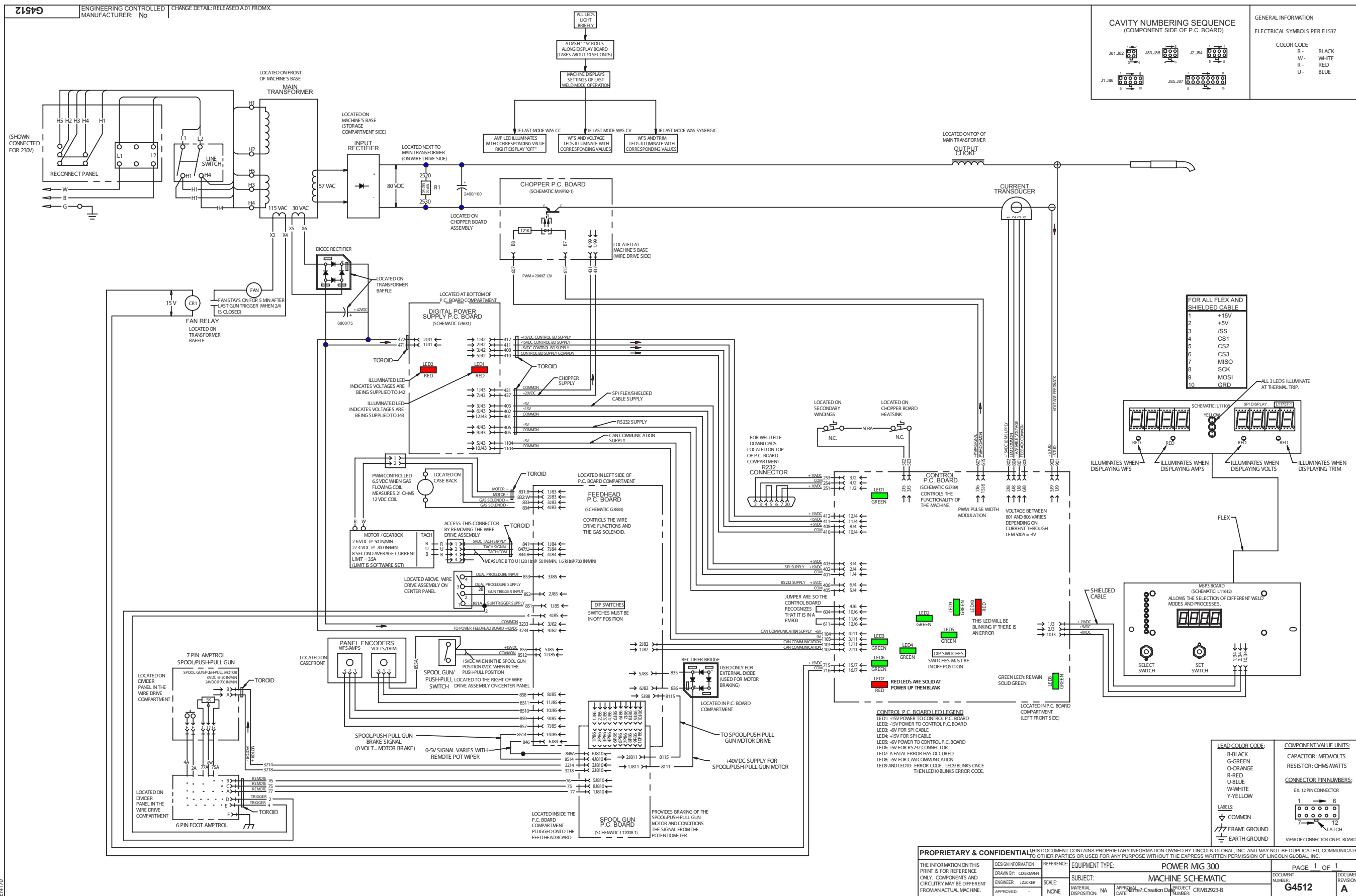

NOTE: This diagram is for reference only. It may not be accurate for all machines covered by this manual.

Return to Section TOC

Return to Section TOC

Return to Section TOC

Return to Section TOC

Return to Master TOC

Return to Master TOC

Return to Master TOC

Return to Master TOC

SCHEMATIC - DIGITAL CONTROL PC BOARD #1 - CODE 10562 - 11098

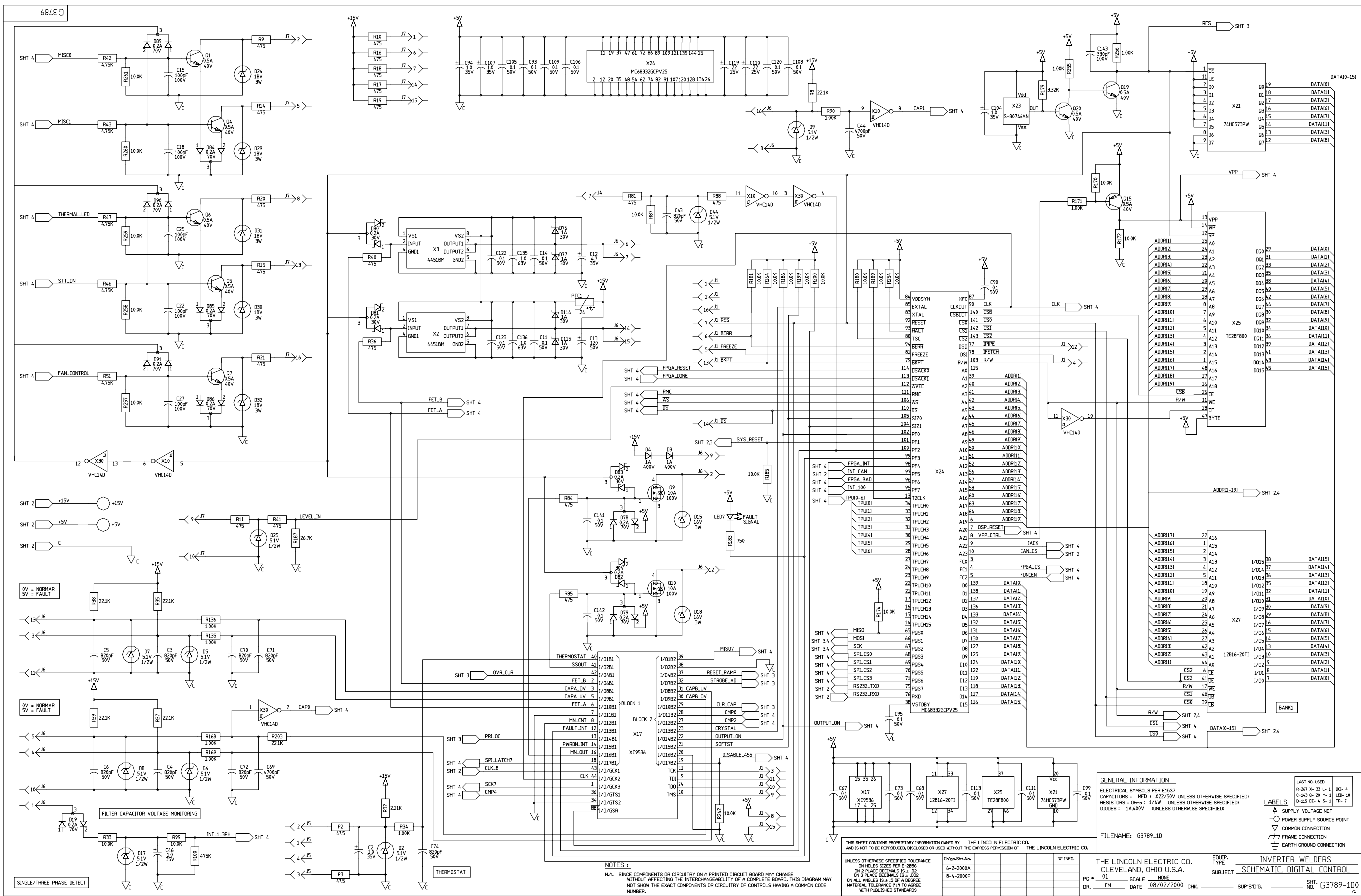

NOTE: This diagram is for reference only. It may not be accurate for all machines covered by this manual.

Return to Section TOC
Return to Section TOC
Return to Section TOC
Return to Section TOC
Return to Section TOC
Return to Section TOC
Return to Section TOC
Return to Section TOC



SCHEMATIC - DIGITAL CONTROL PC BOARD #2 - CODE 10562 - 11098

Return to Section TOC
Return to Master TOC

Return to Section TOC
Return to Master TOC

Return to Section TOC
Return to Master TOC

Return to Section TOC
Return to Master TOC

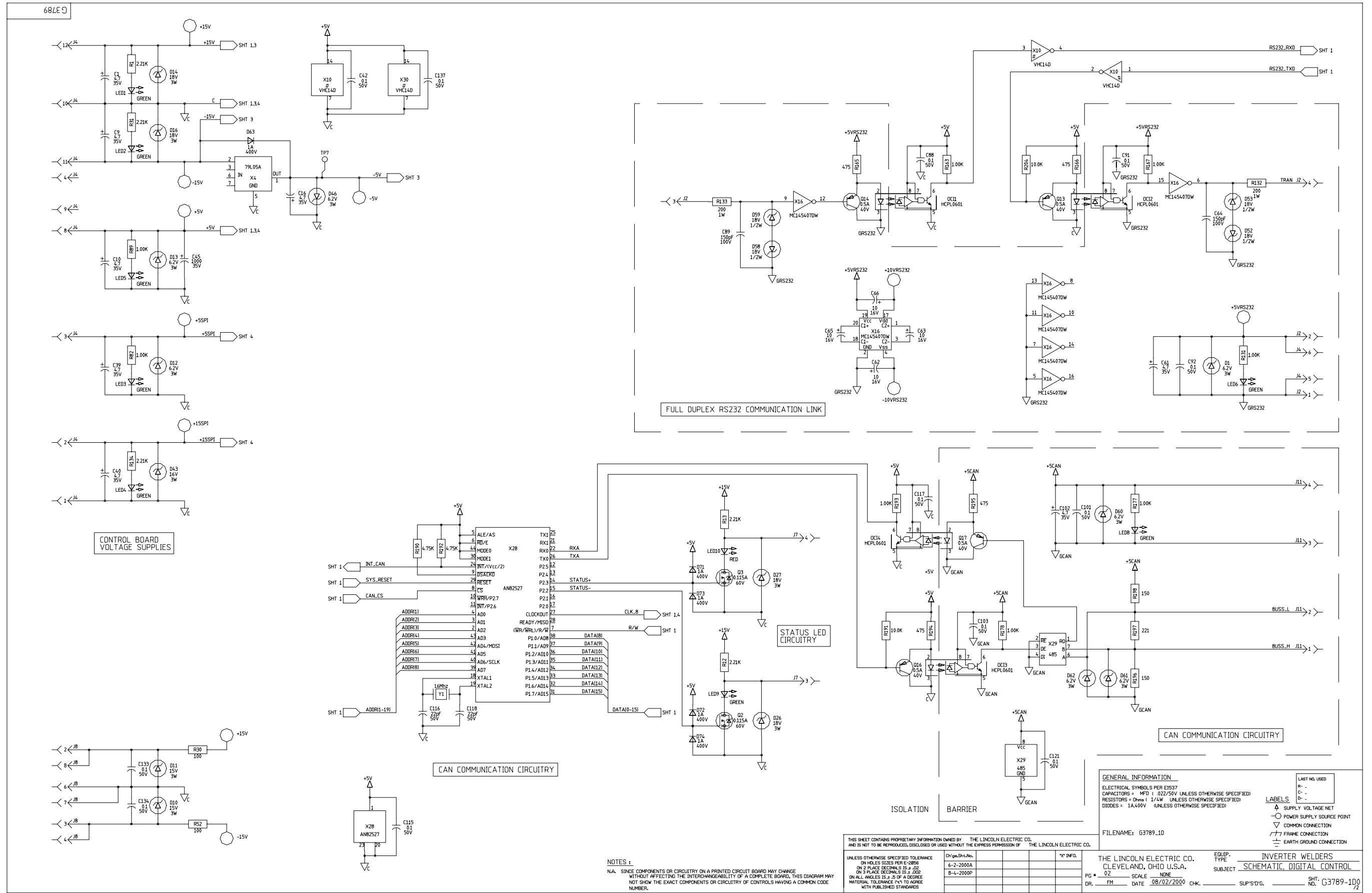

NOTES:
 N.A. SINCE COMPONENTS OR CIRCUITRY ON A PRINTED CIRCUIT BOARD MAY CHANGE WITHOUT AFFECTING THE INTERCHANGEABILITY OF A COMPLETE BOARD, THIS DIAGRAM MAY NOT SHOW THE EXACT COMPONENTS OR CIRCUITRY OF CONTROLS HAVING A COMMON CODE NUMBER.

THIS SHEET CONTAINS PROPRIETARY INFORMATION OWNED BY THE LINCOLN ELECTRIC CO. AND IS NOT TO BE REPRODUCED, DISCLOSED OR USED WITHOUT THE EXPRESS PERMISSION OF THE LINCOLN ELECTRIC CO.		DR.	FM	DATE	08/02/2000	CHK.	SUP'D'G.	SHT. NO.	G3789-10/2
OTHER SPECIFIED TOLERANCE	ON HOLES SIZES PER ASME B94.1	6-2-2000A	8-4-2000P	MATERIAL TOLERANCE (*) TO AGREE WITH PUBLISHED STANDARDS					
CH/GRN/SH/NO.	6-2-2000A		8-4-2000P		MATERIAL TOLERANCE (*) TO AGREE WITH PUBLISHED STANDARDS				
GENERAL INFORMATION		ELECTRICAL SYMBOLS PER E1537		CAPACITORS = MFD (.022/50V UNLESS OTHERWISE SPECIFIED)		RESISTORS = Ohms (1/4W UNLESS OTHERWISE SPECIFIED)		DIODES = 1A/400V (UNLESS OTHERWISE SPECIFIED)	
EQUIP. TYPE		INVERTER WELDERS		SUBJECT		SCHEMATIC, DIGITAL CONTROL			
PG. #		02		SCALE		NONE			
DR.		FM		DATE		08/02/2000		SHT. NO.	
FILENAME:		G3789_10		LAST NO. USED					
LABELS		SUPPLY VOLTAGE NET		POWER SUPPLY SOURCE POINT		COMMON CONNECTION		FRAME CONNECTION	
EARTH GROUND CONNECTION									

NOTE: This diagram is for reference only. It may not be accurate for all machines covered by this manual.



SCHEMATIC - DIGITAL CONTROL PC BOARD #4 - CODE 10562 - 11098

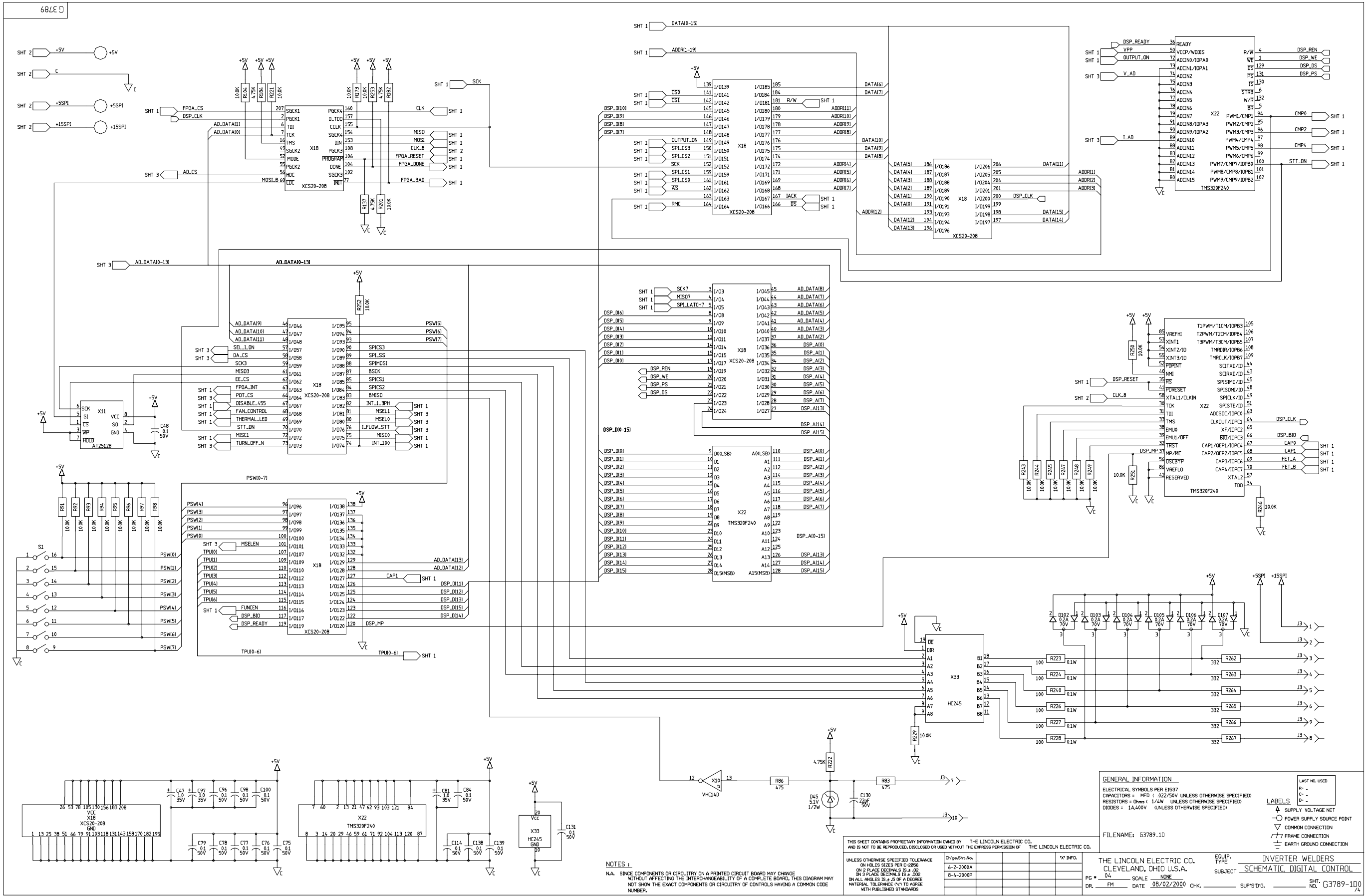

NOTES:
 N.A. SINCE COMPONENTS OR CIRCUITRY ON A PRINTED CIRCUIT BOARD MAY CHANGE WITHOUT AFFECTING THE INTERCHANGEABILITY OF A COMPLETE BOARD, THIS DIAGRAM MAY NOT SHOW THE EXACT COMPONENTS OR CIRCUITRY OF CONTROLS HAVING A COMMON CODE NUMBER.

UNLESS OTHERWISE SPECIFIED TOLERANCE
 ON HOLES SIZES PER E-2086
 ON 2 PLACE DECIMALS IS ± .02
 ON 3 PLACE DECIMALS IS ± .002
 ON ALL ANGLES IS ± 5 OF A DEGREE
 MATERIAL TOLERANCE IS TO AGREE
 WITH PUBLISHED STANDARDS

GENERAL INFORMATION
 ELECTRICAL SYMBOLS PER E1537
 CAPACITORS = MFD (.022/50V UNLESS OTHERWISE SPECIFIED)
 RESISTORS = Ohms (1/4W UNLESS OTHERWISE SPECIFIED)
 DIODES = 1A,400V UNLESS OTHERWISE SPECIFIED

FILENAME: G3789.10
 THE LINCOLN ELECTRIC CO.
 CLEVELAND, OHIO U.S.A.
 PG # 04 SCALE: NONE
 DR. FM DATE 08/22/2000 CHK. _____
 EQUIP. TYPE: INVERTER WELDERS
 SUBJECT: SCHEMATIC, DIGITAL CONTROL
 SUP'D'G. SHT. NO. G3789-100/4

NOTE: This diagram is for reference only. It may not be accurate for all machines covered by this manual.



Return to Section TOC

SCHEMATIC - POWER SUPPLY PRINTED CIRCUIT BOARD - CODE 10562 - 11098

Return to Section TOC
Return to Master TOC

Return to Section TOC
Return to Master TOC

Return to Section TOC
Return to Master TOC

Return to Section TOC
Return to Master TOC

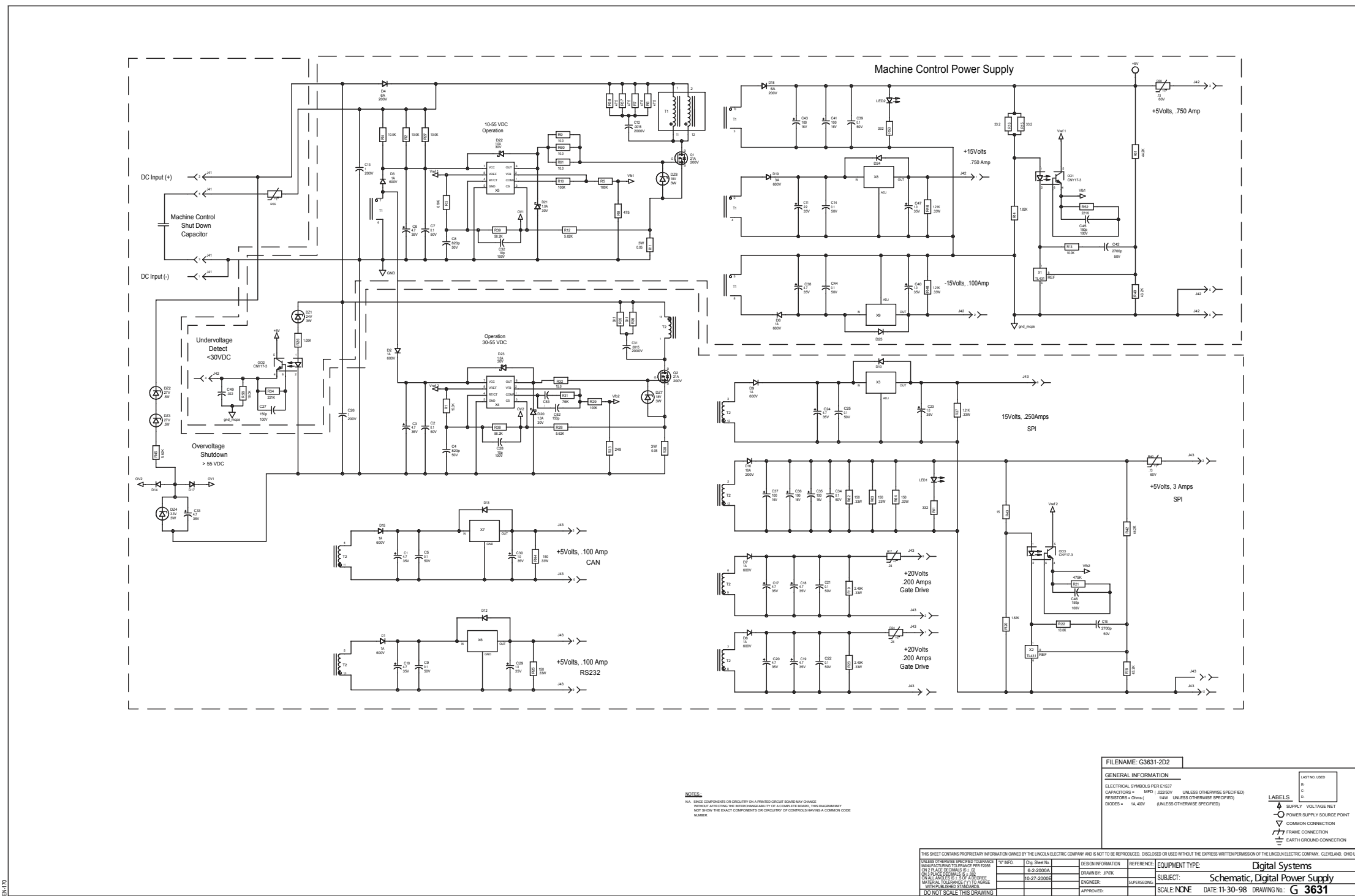

NOTES:
 1. ALL DIMENSIONS ARE TO CENTER UNLESS OTHERWISE SPECIFIED.
 2. DIMENSIONS ARE TO CENTER UNLESS OTHERWISE SPECIFIED.
 3. DIMENSIONS ARE TO CENTER UNLESS OTHERWISE SPECIFIED.
 4. DIMENSIONS ARE TO CENTER UNLESS OTHERWISE SPECIFIED.

FILENAME: G3631-2D2
GENERAL INFORMATION
ELECTRICAL SYMBOLS PER #1537
CAPACITORS - MFD (UNLESS OTHERWISE SPECIFIED)
RESISTORS - OHMS (UNLESS OTHERWISE SPECIFIED)
DIODES - 1A, 40V (UNLESS OTHERWISE SPECIFIED)

- LABELS
- ▲ SUPPLY VOLTAGE NET
 - POWER SUPPLY SOURCE POINT
 - ▽ COMMON CONNECTION
 - FRAME CONNECTION
 - ⊕ EARTH GROUND CONNECTION

THIS SHEET CONTAINS PROPRIETARY INFORMATION OWNED BY THE LINCOLN ELECTRIC COMPANY AND IS NOT TO BE REPRODUCED, DISCLOSED OR USED WITHOUT THE EXPRESS WRITTEN PERMISSION OF THE LINCOLN ELECTRIC COMPANY, CLEVELAND, OHIO U.S.A.	DATE: 11-30-98	SCALE: NONE	DRAWING NO.: G 3631
DESIGNER: JPTK	ENGINEER:	SUPERVISOR:	APPROVED:
DATE: 11-30-98	DATE: 11-30-98	DATE: 11-30-98	DATE: 11-30-98

NOTE: This diagram is for reference only. It may not be accurate for all machines covered by this manual.



SCHEMATIC - MSP3 PC BOARD - CODE 10562 - 11098

Return to Section TOC
Return to Master TOC

Return to Section TOC
Return to Master TOC

Return to Section TOC
Return to Master TOC

Return to Section TOC
Return to Master TOC

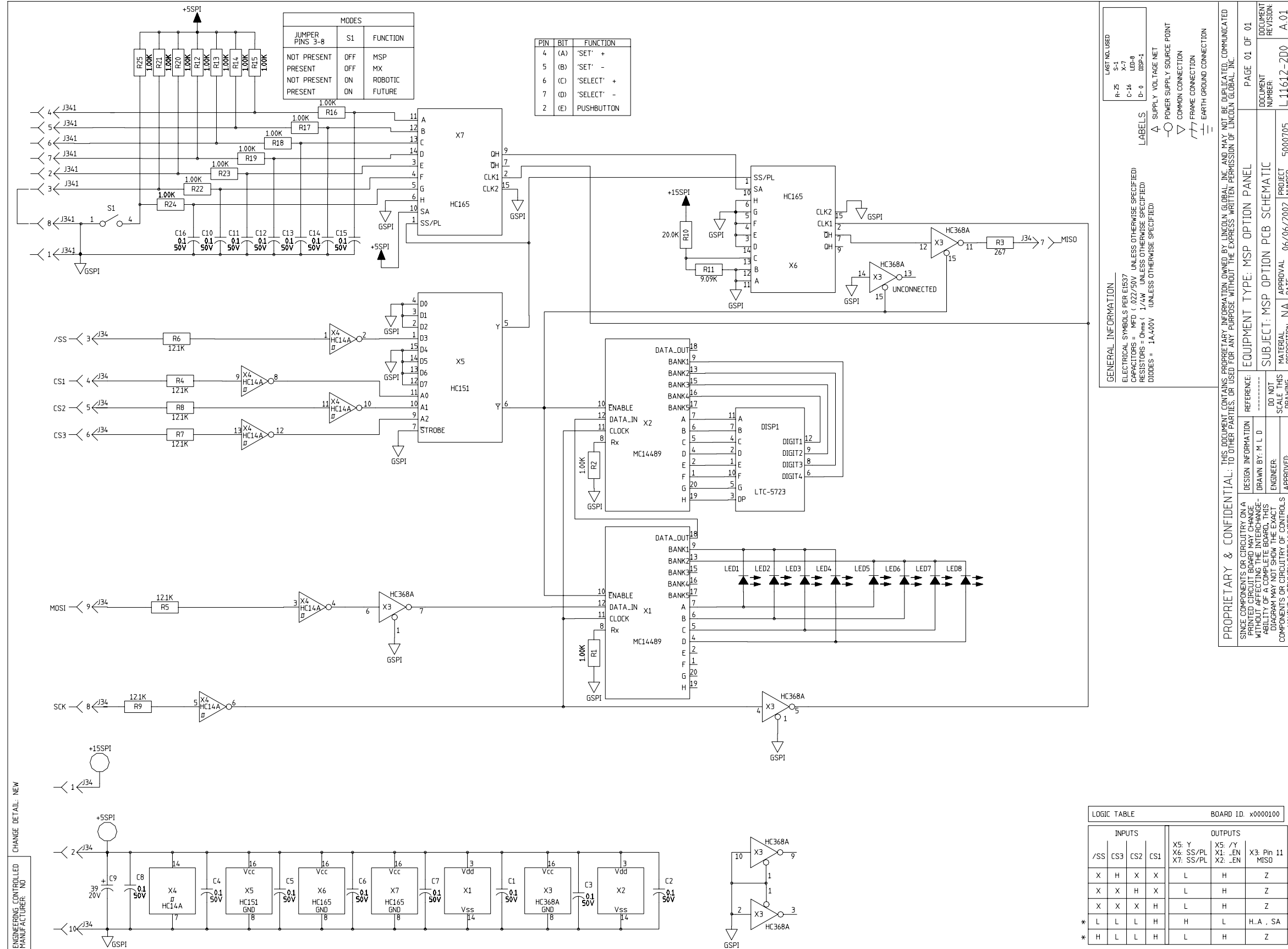

NOTE: This diagram is for reference only. It may not be accurate for all machines covered by this manual.

PC BOARD ASSEMBLY - MSP3 PANEL - CODE 10562 - 11098

Return to Section TOC
Return to Master TOC

Return to Section TOC
Return to Master TOC

Return to Section TOC
Return to Master TOC

Return to Section TOC
Return to Master TOC

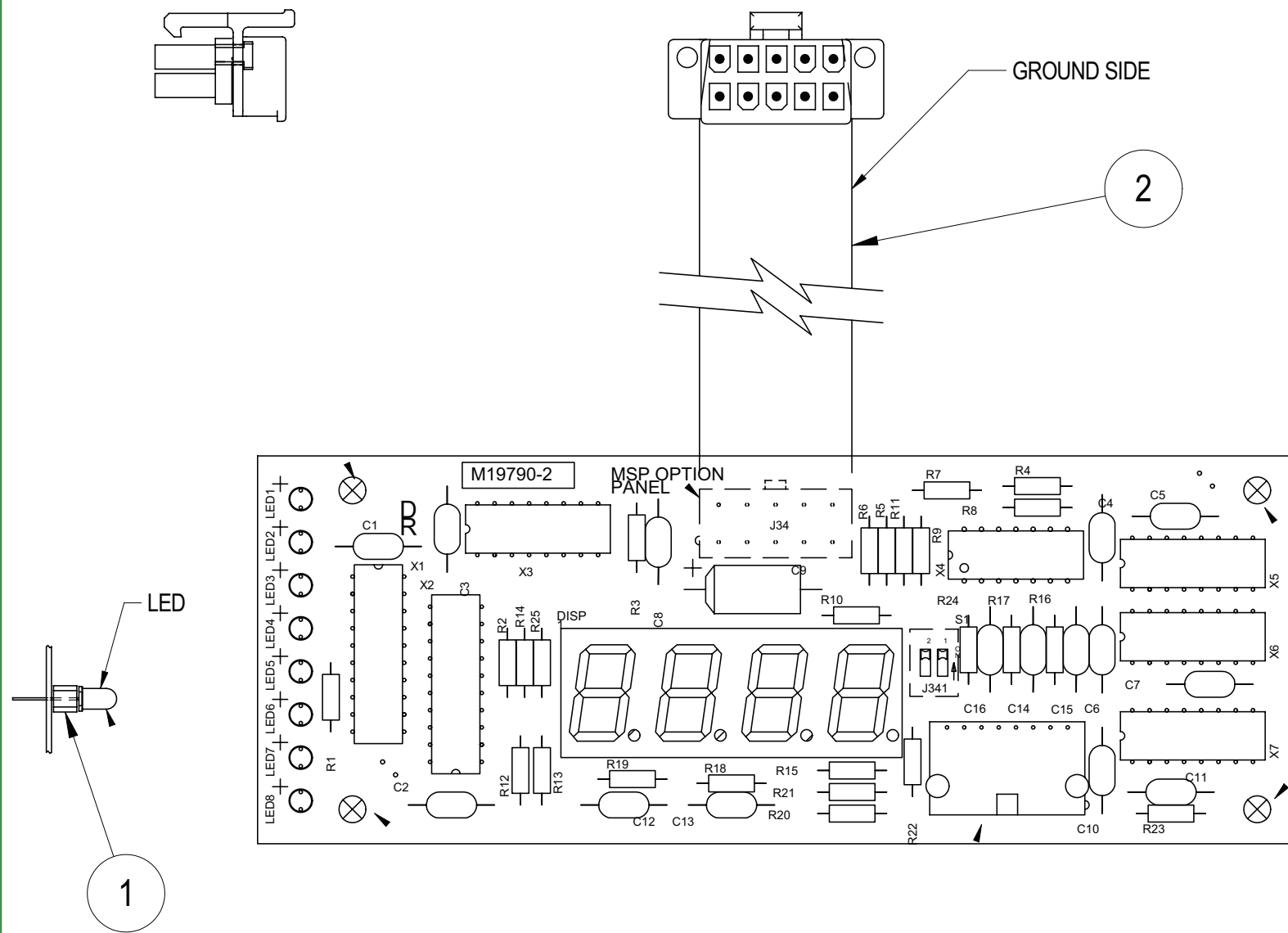

ITEM	REQ'D	PART No.	DESCRIPTION
1	8	T15176-2	LED SPACER
2	1	L11166-1	FLEX CIRCUIT
3	.01 OZ.	E3539	ELECTRICAL INSULATING COMPOUND

FOR ITEMS BELOW REFER TO ELECTRONIC COMPONENTS DATABASE FOR COMPONENT SPECIFICATIONS

C1,C2,C3,C4,C5,C6,C7,C8,C10 C11,C12,C13,C14,C15,C16	15	S16668-11	CAPACITOR,CEMO,0.1, 50V,10%
C9	1	S13490-104	CAPACITOR,TAEL,39,20V,10%
DISP1	1	S17395-9	LED,DISPLAY,7-SEGMENT,CC,4-DIGIT
J34	1	S18248-10	CONNECTOR,MOLEX,MINI,PCB,10-PIN
J341	1	S19365-8	CONNECTOR,PCB,MALE,RT-L,8-PIN
LED1,LED2,LED3,LED4,LED5 LED6,LED7,LED8	8	T13657-6	LED,T-1,RED,HLMP-K101
R1,R2,R12,R13,R14,R15,R16 R17,R18,R19,R20,R21,R22 R23,R24,R25	16	S19400-1001	RESISTOR,MF,1/4W,1.00K,1%
R3	1	S19400-2670	RESISTOR,MF,1/4W,267,1%
R4,R5,R6,R7,R8,R9	6	S19400-1212	RESISTOR,MF,1/4W,12.1K,1%
R10	1	S19400-2002	RESISTOR,MF,1/4W,20.0K,1%
R11	1	S19400-9091	RESISTOR,MF,1/4W,9.09K,1%
X1,X2	2	S20496-1	IC,CMOS,DRIVER,DISPLAY,LED,CC,MCU
X3	1	S17900-28	IC,CMOS,HEX,BUFFER,3-STATE,2-BIT,4-BI
X4	1	S17900-8	IC,CMOS,INVERTER,SCHMITT,HEX,HC14A(SS
X5	1	S17900-26	IC,CMOS,MUX,DAT,8-INPUT,HC151(SS)
X6,X7	2	S17900-10	IC,CMOS,REGISTER,SHFT,S-PI/SO,8-BIT(S
S1	1	S19869-2	SWITCH,DIP,SPST,2-CIRCUITS

UNLESS OTHERWISE SPECIFIED:
CAPACITANCE = MFD/VOLTS
INDUCTANCE = HENRIES
RESISTANCE = OHMS

A
M19790-2

NOTE: Lincoln Electric assumes no responsibility for liabilities resulting from board level troubleshooting. PC Board repairs will invalidate your factory warranty. **Individual Printed Circuit Board Components are not available from Lincoln Electric.** This information is provided for reference only. Lincoln Electric discourages board level troubleshooting and repair since it may compromise the quality of the design and may result in danger to the Machine Operator or Technician. Improper PC board repairs could result in damage to the machine.

SCHEMATIC - FEEDER PC BOARD BOARD - CODE 10562 - 11098 - SHEET 1

Return to Section TOC
Return to Master TOC

Return to Section TOC
Return to Master TOC

Return to Section TOC
Return to Master TOC

Return to Section TOC
Return to Master TOC

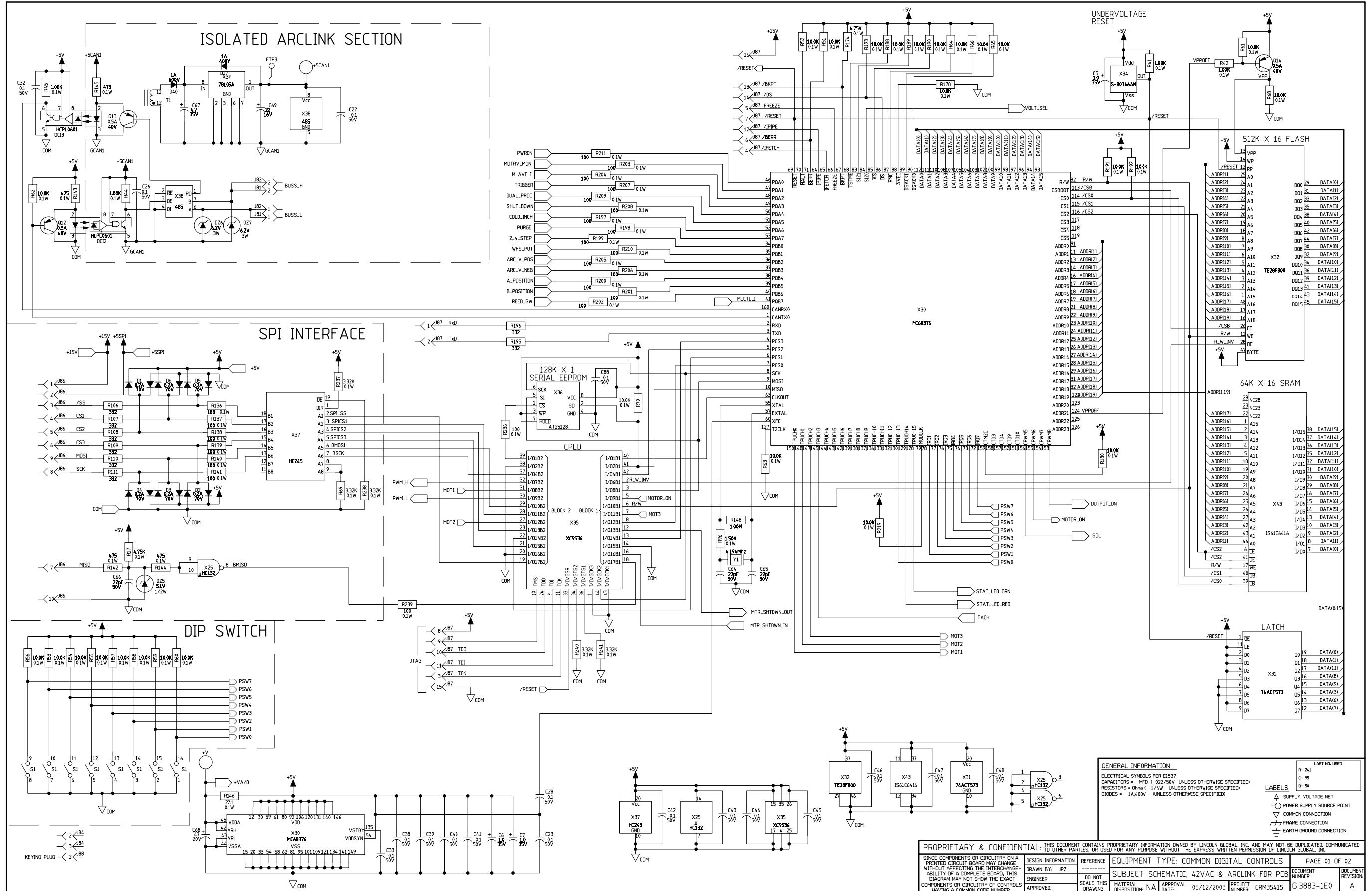

GENERAL INFORMATION		LAST NO. USED	
ELECTRICAL SYMBOLS PER E1537		A-24	
CAPACITORS = MFD (0.22/50V UNLESS OTHERWISE SPECIFIED)		C-15	
RESISTORS = Ohms (1/4W UNLESS OTHERWISE SPECIFIED)		D-59	
DIODES = 1A,400V UNLESS OTHERWISE SPECIFIED			

PROPRIETARY & CONFIDENTIAL		EQUIPMENT TYPE: COMMON DIGITAL CONTROLS		PAGE 01 OF 02	
SINCE COMPONENTS OR CIRCUITRY ON A PRINTED CIRCUIT BOARD MAY CHANGE WITHOUT AFFECTING THE INTERCHANGEABILITY OF A COMPLETE BOARD, THIS DIAGRAM MAY NOT SHOW THE EXACT COMPONENTS OR CIRCUITRY OF CONTROLS HAVING A COMMON CODE NUMBER.					
DESIGN INFORMATION	REFERENCE:	SUBJECT: SCHEMATIC, 42VAC & ARCLINK FOR PCB		DOCUMENT NUMBER	REVISION
DRAWN BY: JPZ	DO NOT SCALE THIS DRAWING	MATERIAL DISPOSITION	NA	PROJECT NUMBER: CRM35415	G 3883-1E0
ENGINEER:	APPROVED:	DATE:	05/12/2003	APPROVAL NUMBER:	A

NOTE: This diagram is for reference only. It may not be accurate for all machines covered by this manual.

SCHEMATIC - FEEDER PC BOARD BOARD - CODE 10562 - 11098 - SHEET 2

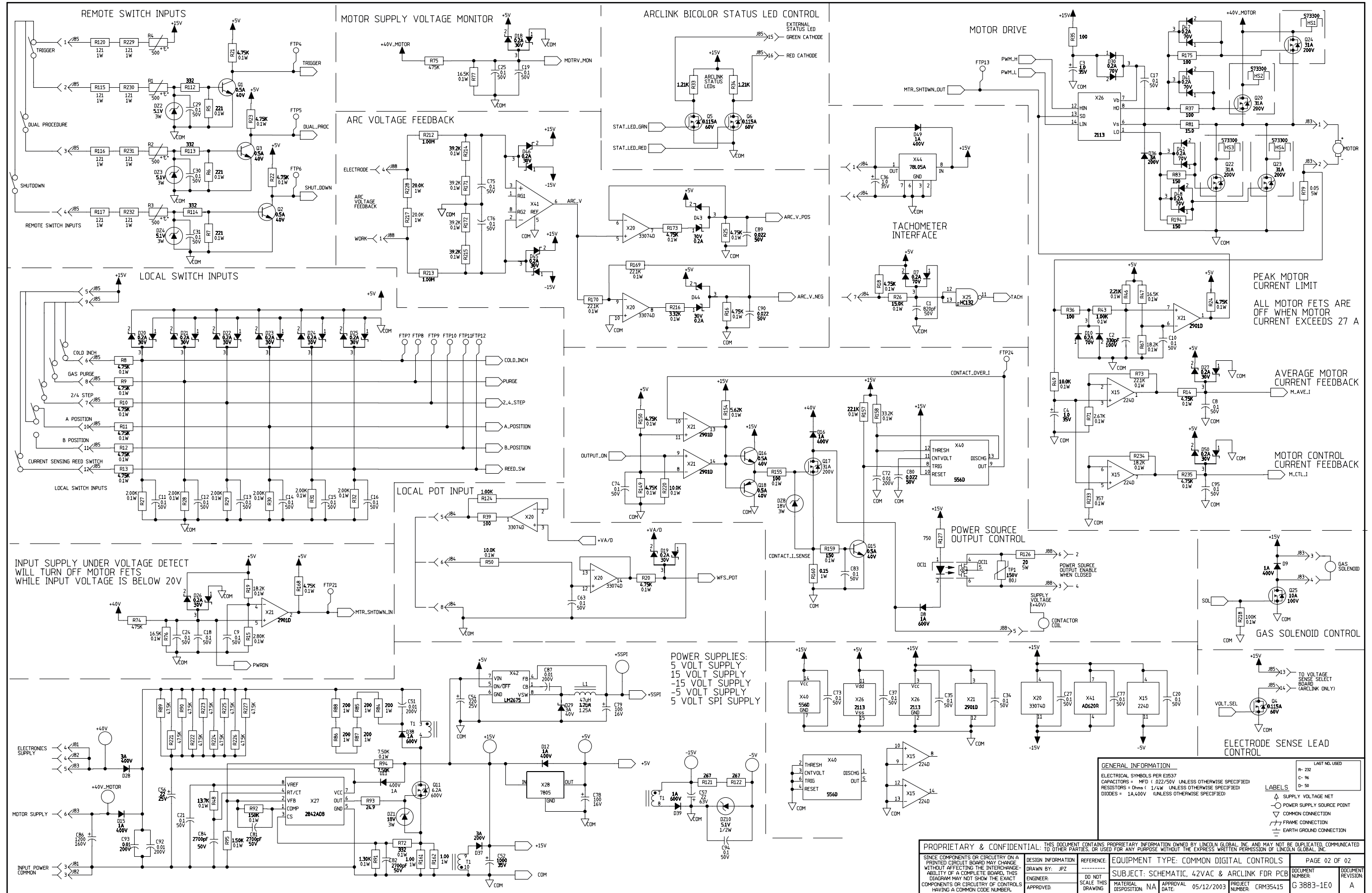

NOTE: This diagram is for reference only. It may not be accurate for all machines covered by this manual.

Return to Section TOC
Return to Master TOC
Return to Section TOC
Return to Master TOC
Return to Section TOC
Return to Master TOC
Return to Section TOC
Return to Master TOC

SCHEMATIC - SPOOL GUN PC BOARD - CODE 10562 - 11098 - SHEET 1

Return to Section TOC
Return to Master TOC

Return to Section TOC
Return to Master TOC

Return to Section TOC
Return to Master TOC

Return to Section TOC
Return to Master TOC

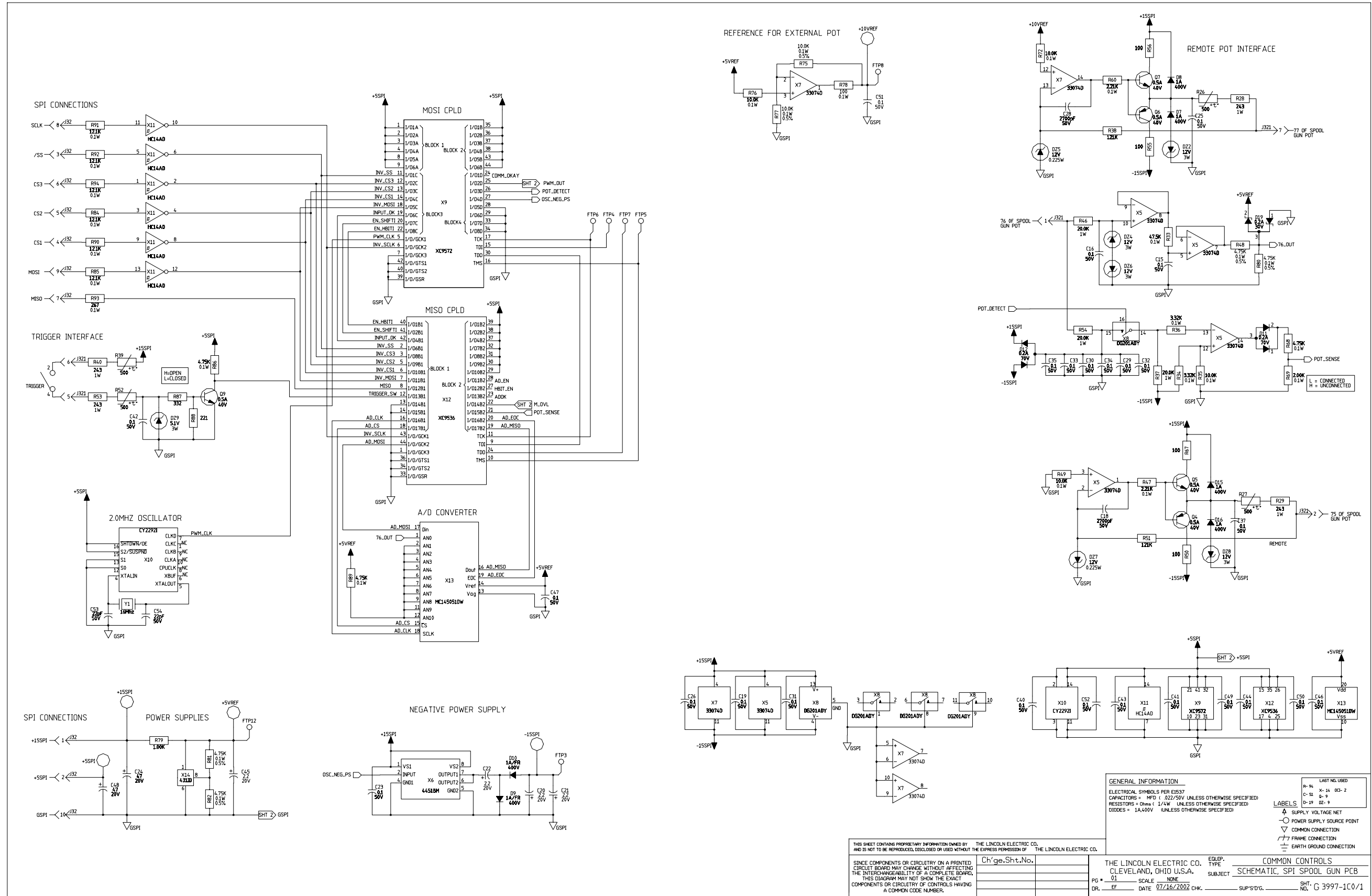

NOTE: This diagram is for reference only. It may not be accurate for all machines covered by this manual.

SCHEMATIC - SPOOL GUN PC BOARD - CODE 10562 - 11098 - SHEET 2

Return to Section TOC
Return to Master TOC

Return to Section TOC
Return to Master TOC

Return to Section TOC
Return to Master TOC

Return to Section TOC
Return to Master TOC

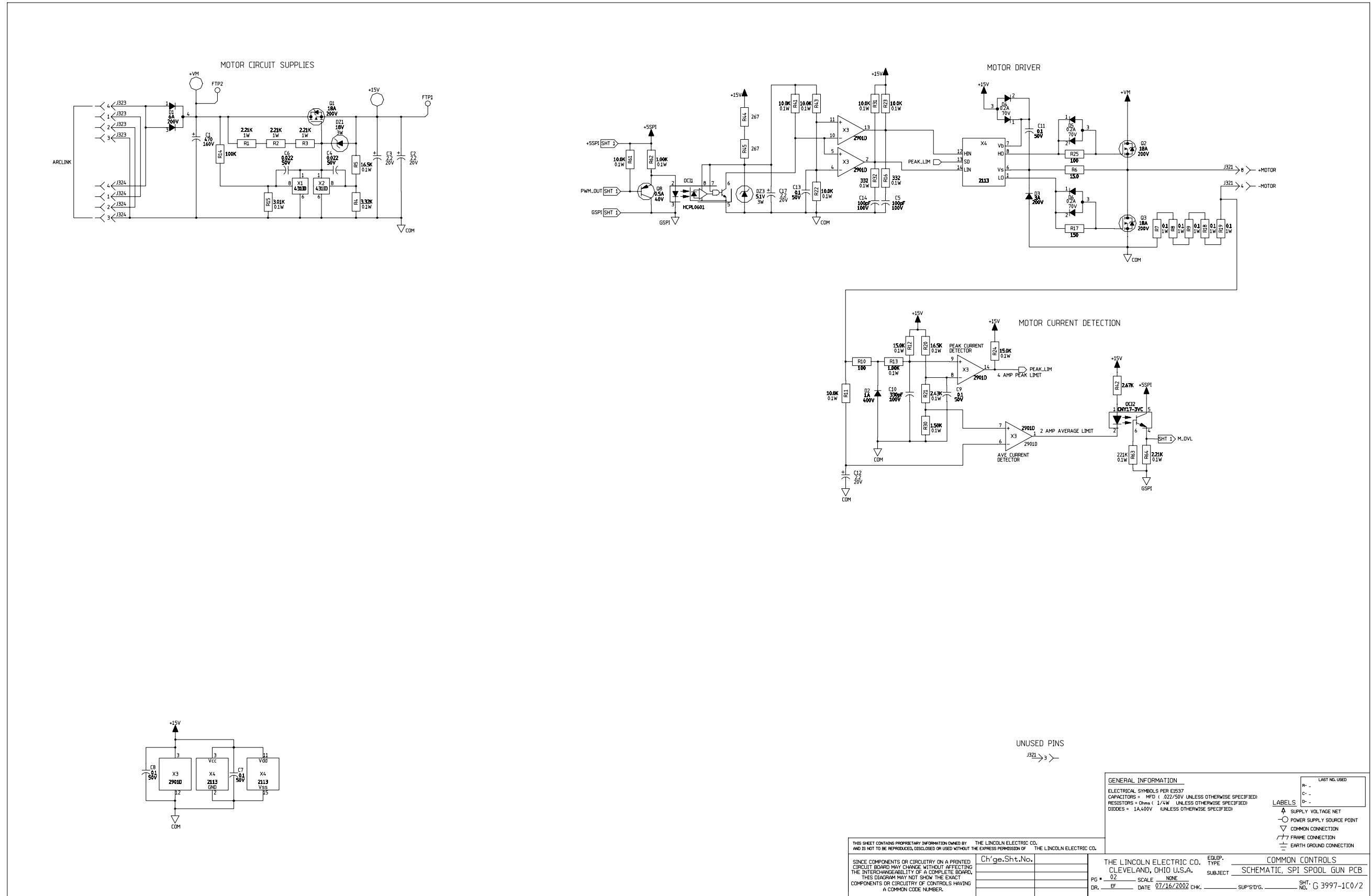

GENERAL INFORMATION

ELECTRICAL SYMBOLS PER E1837
 CAPACITORS = MFD (0.22/50V UNLESS OTHERWISE SPECIFIED)
 RESISTORS = OHMS (1/4W UNLESS OTHERWISE SPECIFIED)
 DIODES = 1A,400V (UNLESS OTHERWISE SPECIFIED)

LAST NO. USED
 R -
 C -
 D -

LABELS

▲ SUPPLY VOLTAGE NET
 ○ POWER SUPPLY SOURCE POINT
 ▽ COMMON CONNECTION
 ▤ FRAME CONNECTION
 ⊥ EARTH GROUND CONNECTION

THIS SHEET CONTAINS PROPRIETARY INFORMATION OWNED BY THE LINCOLN ELECTRIC CO. AND IS NOT TO BE REPRODUCED, DISCLOSED OR USED WITHOUT THE EXPRESS PERMISSION OF THE LINCOLN ELECTRIC CO.

SINCE COMPONENTS OR CIRCUITRY ON A PRINTED CIRCUIT BOARD MAY CHANGE WITHOUT AFFECTING THE INTERCHANGEABILITY OF A COMPLETE BOARD, THIS DIAGRAM MAY NOT SHOW THE EXACT COMPONENTS OR CIRCUITRY OF CONTROLS HAVING A COMMON CODE NUMBER.

Ch'ge.Sht.No. _____

THE LINCOLN ELECTRIC CO. CLEVELAND, OHIO U.S.A.
 PG # 02 SCALE NONE
 DR. EF DATE 07/16/2002 CHK. _____ SUPP'S'D'G. _____ SHT. NO. G 3997-1C0/2

EQUIP. TYPE COMMON CONTROLS
 SUBJECT SCHEMATIC, SPI SPOOL GUN PCB

NOTE: This diagram is for reference only. It may not be accurate for all machines covered by this manual.



SCHEMATIC - ENCODER PC BOARD - CODE 10562 ONLY

Return to Section TOC

Return to Section TOC

Return to Section TOC

Return to Section TOC

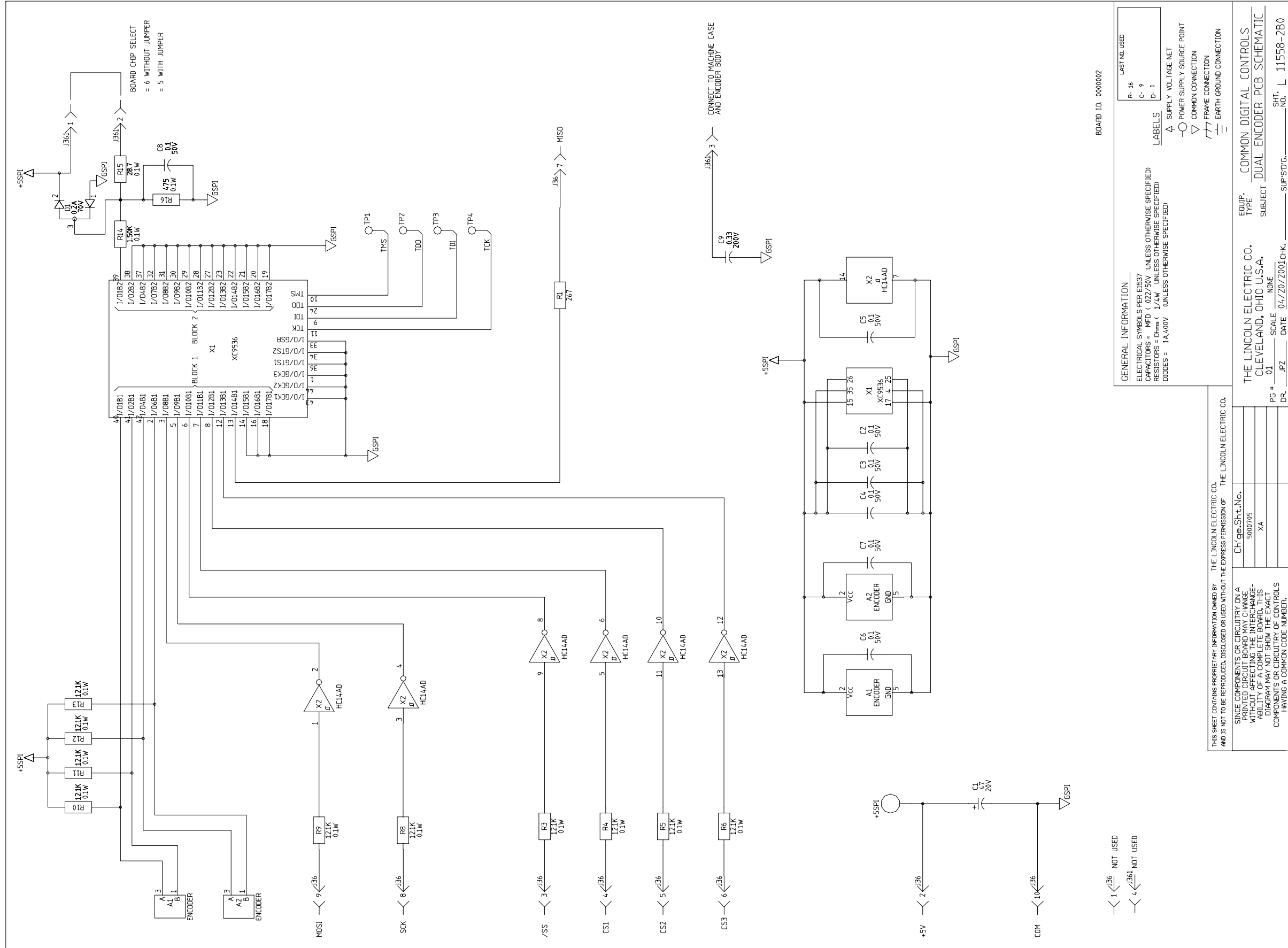

NOTE: This diagram is for reference only. It may not be accurate for all machines covered by this manual.

PC BOARD ASSEMBLY - ENCODER PC BOARD - CODE 10562 ONLY

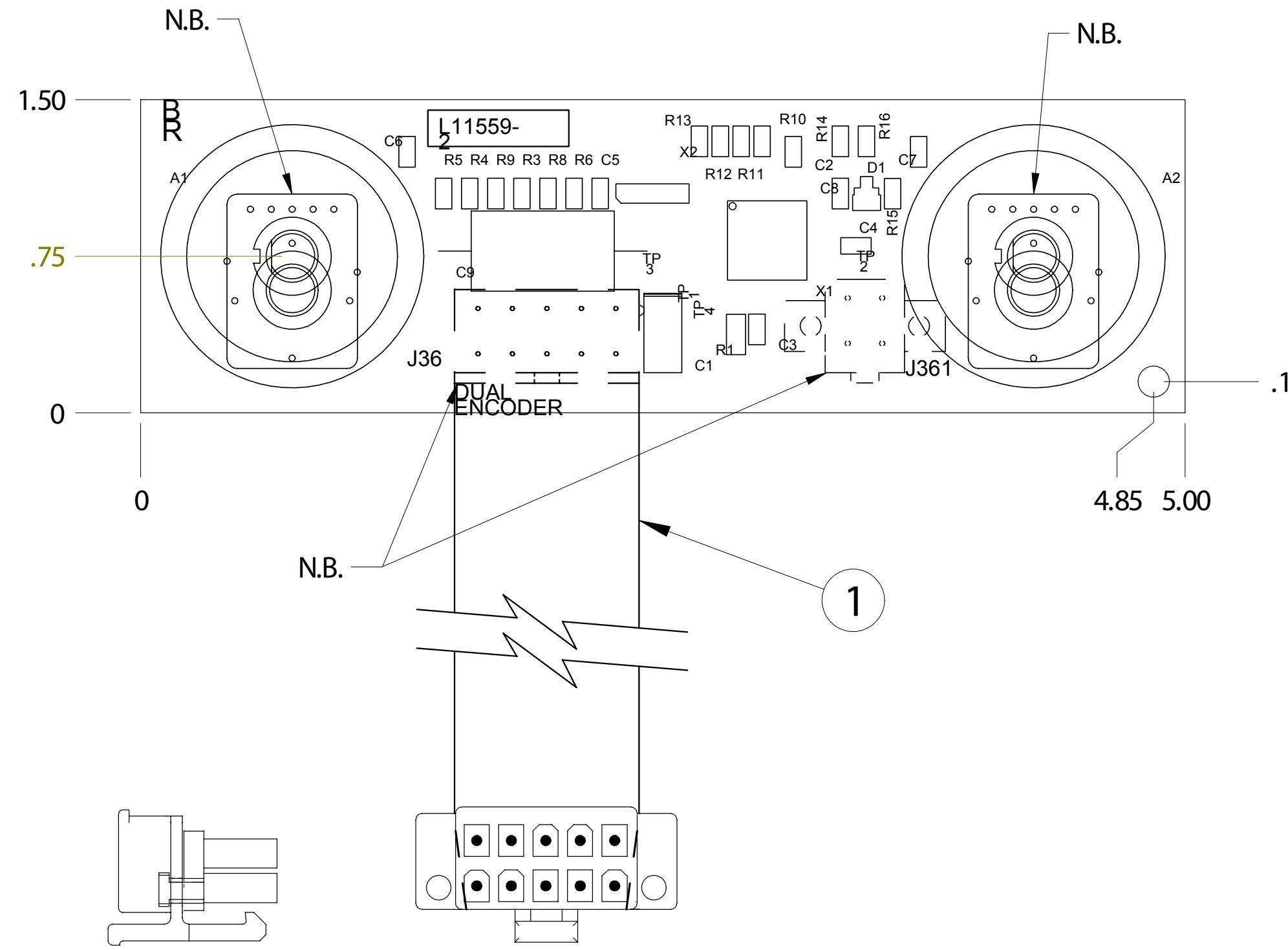

ITEM	R	EQD	PART No.	DESCRIPTION
1		1	L11166-1	FLEX CIRCUIT
2		.01 OZ	E3539	ELECTRICAL INSULATING COMPOUND
3		1	S24951-4	CPLD SOFTWARE
FOR ITEMS BELOW, REFER TO ELECTRONIC COMPONENTS DATABASE FOR COMPONENT SPECIFICATION				
A1,A2		2	M17789-2	ENCODER,ROTARY,OPTICAL,61JY2049
C1		1	S25024-7SMT	CAPACITOR,SMD,TANTALUM,47MF,20V,10%,S7343
C2,C3,C4,C5,C6,C7,C8		7	S25020-3SMT	CAPACITOR,SMD,CERAMIC,0.1MF,50V,10%,X7R,S0805
C9		1	S13490-94	CAPACITOR,PEMF,0.33,200V,10%
D1		1	S25040-5SMT	DIODE,SMD,DUAL,0.200A,70V,UFR
J36		1	S18248-10	CONNECTOR,MOLEX,MINI,PCB,10-PIN
J361		1	S24020-4	CONNECTOR,MOLEX,MINI,PCB,4-PIN,TIN
R1		1	S25001-2670SMT	RESISTOR,SMD,267OHMS,1/4W,1206,1%,TR
R3,R4,R5,R6,R8,R9		10	S25000-1212SMT	RESISTOR,SMD,METAL FILM,1/10W,12.1K,1%,S0805
R10,R11,R12,R13				
R14		1	S25000-1501SMT	RESISTOR,SMD,METAL FILM,1/10W,1.50K,1%,S0805
R15		1	S25000-28R7SMT	RESISTOR,SMD,METAL FILM,1/10W,28.7OHMS,1%,S0805
R16		1	S25000-4750SMT	RESISTOR,SMD,METAL FILM,1/10W,475OHMS,1%,S0805
X1	N.A.	1	S25070-3SMT	CPLD,PROGRAMMABLE,XC9536,44-PIN,VQFP(SS)
X2	N.A.	1	S17900-8SMT	IC,SMD,CMOS,INVERTER,SCHMITT,HEX,HC14A(SS)

12-21-2001A
L 11559-2

NOTE: Lincoln Electric assumes no responsibility for liabilities resulting from board level troubleshooting. PC Board repairs will invalidate your factory warranty. **Individual Printed Circuit Board Components are not available from Lincoln Electric.** This information is provided for reference only. Lincoln Electric discourages board level troubleshooting and repair since it may compromise the quality of the design and may result in danger to the Machine Operator or Technician. Improper PC board repairs could result in damage to the machine.



Return to Section TOC
Return to Master TOC
Return to Section TOC
Return to Master TOC
Return to Section TOC
Return to Master TOC
Return to Section TOC
Return to Master TOC

SCHEMATIC - DISPLAY PC BOARD - CODE 10562 - 11098

Return to Section TOC
Return to Master TOC

Return to Section TOC
Return to Master TOC

Return to Section TOC
Return to Master TOC

Return to Section TOC
Return to Master TOC

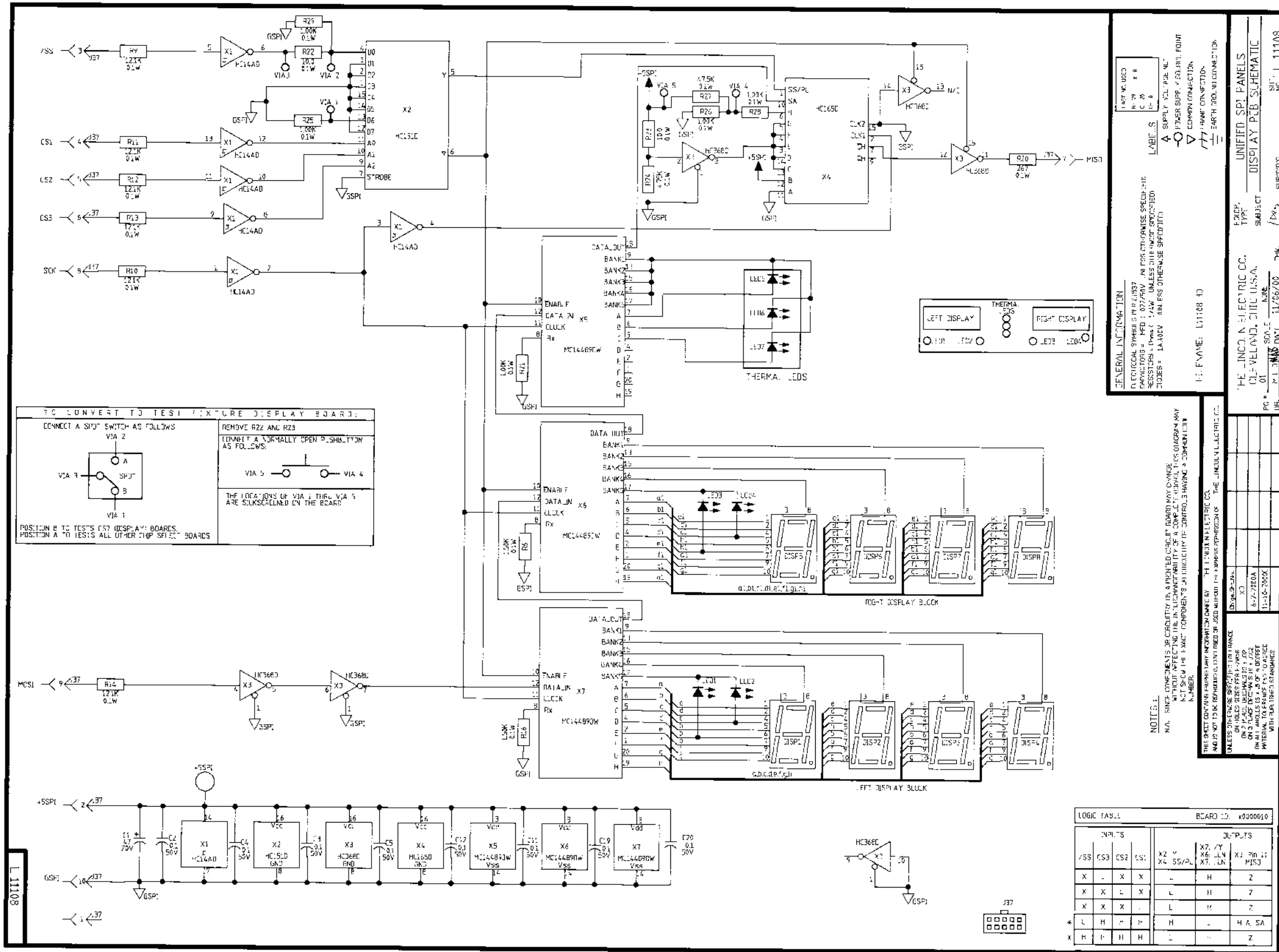

NOTE: This diagram is for reference only. It may not be accurate for all machines covered by this manual.

PC BOARD ASSEMBLY - DISPLAY PC BOARD - CODE 10562 - 11098

Return to Section TOC
Return to Master TOC

Return to Section TOC
Return to Master TOC

Return to Section TOC
Return to Master TOC

Return to Section TOC
Return to Master TOC

L11757-1	ENGINEERING CONTROLLED MANUFACTURER: Yes	CHANGE DLTAIL, LED5, 6 & 7, REVISED PART NUMBER AND DESCRIPTION, REVISED IDENTIFICATION CODE AND SCHEMATIC REF NUMBER
-----------------	---	---

ITEM / REFERENCE DESIGNATORS	QTY	PART NUMBER	DESCRIPTION
1	1	L11757-E	P.C. BOARD BLANK
2	4	T15178-2	LED SPACER, 0.140 HIGH
3	01 OZ	E3539	ELECTRICAL INSULATING COMPOUND
FOR ITEMS BELOW REFER TO ELECTRONIC COMPONENTS DATABASE FOR COMPONENT SPECIFICATIONS			
C1	1	S25024-7SMT	CAPACITOR, SMD, TANTALUM, 47MF, 20V, 10%, S7343
C2, C3, C4, C5, C11, C12, C19, C20	8	S25020-3SMT	CAPACITOR, SMD, CERAMIC, 0.1MF, 50V, 0%, X7R, S0805
N.A., N.D. DISP1, DISP2	2	S17395-9	LED DISPLAY, 7-SEGMENT, CC, 4-DIGIT
J37	1	S18248-10	CONNECTOR, MOLEX/MINI/PCB, 10-PIN
N.C. LED1, LED2, LED3, LED4	4	T13357-6	LED, T-1, RED, HLMF, K101
N.A. LED5, LED6, LED7	3	T13857-14	LED, T-1, 3/4, AMBER, HIGH-INTENSITY
R6, R16	2	S25000-1501SMT	RESISTOR, SMD, METAL FILM, 1/10W, 1.50K, 1%, S0805
R9, R10, R11, R12, R13, R14	6	S25000-1212SMT	RESISTOR, SMD, METAL FILM, 1/10W, 12.1K, 1%, S0805
R20	1	S25000-2670SMT	RESISTOR, SMD, METAL FILM, 1/10W, 2670 OHMS, 1%, S0805
R21, R25, R26, R28, R29	5	S25000-1001SMT	RESISTOR, SMD, METAL FILM, 1/10W, 1.00K, 1%, S0805
R22, R23	2	S25000-1000SMT	RESISTOR, SMD, METAL FILM, 1/10W, 10.00 OHMS, 1%, S0805
R24	1	S25000-4751SMT	RESISTOR, SMD, METAL FILM, 1/10W, 4.75K, 1%, S0805
R27	1	S25000-4752SMT	RESISTOR, SMD, METAL FILM, 1/10W, 47.5K, 1%, S0805
N.A. X1	1	S17900-8SMT	IC, SMD, CMOS, INVERTER, SCHMITT HEXHC14A(SS)
N.A. X2	1	S17900-26SMT	IC, CMOS, SMD, MUX, DATA INPUT, IC151(S)
N.A. X3	1	S17900-28SMT	IC, SMD, CMOS, HEX INVERTING BUFFER, 3-ST (SS)
N.A. X4	1	S17900-10SMT	IC, SMD, CMOS, REGISTER, SHIFT, S-PUSO, 8-BIT(SS)
N.A. X5, X6, X7	3	S20496-1SMT	IC, SMD, CMOS, DRIVER, DISPLAY LED, CC, MCJ

SCHEMATIC REFERENCE: L11757-1E1

UNLESS OTHERWISE SPECIFIED:
CAPACITANCE - MICROVOLTS
RESISTANCE - OHMS
INDUCTANCE - HENRIES

NOTE:
N.A. CAUTION: THIS DEVICE SUBJECT TO DAMAGE BY STATIC ELECTRICITY. SEE E2454 BEFORE HANDLING.
N.B. DO NOT COAT WITH ENCAPSULATION MATERIAL.
N.C. USE ITEM 2 TO STAND LED1, LED2, LED3 AND LED4 FROM THE P.C. BOARD. THERE MUST NOT BE MORE THAN .020 GAP BETWEEN SPACER AND P.C. BOARD OR BETWEEN SPACER AND LED. ENCAPSULATE P.C. BOARD, SPACER AND LOWER HALF OF LED.
N.D. DISP1 AND DISP2 MUST ALWAYS BE MATCHED BY VENDOR NAME. DO NOT MIX DIFFERENT VENDORS ON THE SAME BOARD ASSEMBLY. ENCAPSULATE LOWER HALF OF DISPLAYS ONLY. FACE AND UPPER HALF MUST BE FREE OF ENCAPSULATION.
N.E. CONNECTOR MUST BE GREASED WITH ITEM 3 PRIOR TO ENCAPSULATION.

BUY AS:

L11757-1E1

IDENTIFICATION CODE

ENCAPSULATE WITH HUMISEAL 1A27LUJ
PER E1844 OR WITH EQUIVALENT AS
APPROVED BY LINCOLN ELECTRIC COMPANY.
(2 COATS)

BUY PER E3867
TEST PER E3856-D

PROPRIETARY & CONFIDENTIAL - THIS DOCUMENT CONTAINS PROPRIETARY INFORMATION OWNED BY LINCOLN GLOBAL, INC. AND MAY NOT BE DUPLICATED, COMMUNICATED TO OTHER PARTIES OR USED FOR ANY PURPOSE WITHOUT THE EXPRESS WRITTEN PERMISSION OF LINCOLN GLOBAL, INC.		PAGE 1 OF 1
DESIGN INFORMATION DESIGNED BY: [Signature] DRAWN BY: [Signature] ENGINEER: [Signature]	REFERENCE SCALE: 1:1	EQUIPMENT TYPE: MISCELLANEOUS
SUBJECT: SPI DISPLAY P.C. BOARD ASSEMBLY		DOCUMENT REV. NO.: A
MATERIAL DISPOSITION: [Signature]	APPROVAL DATE: 11/05/00	PROJECT NUMBER: C-103655
DO NOT SCALE THIS DRAWING		DOCUMENT NUMBER: L11757-1

NOTE: Lincoln Electric assumes no responsibility for liabilities resulting from board level troubleshooting. PC Board repairs will invalidate your factory warranty. **Individual Printed Circuit Board Components are not available from Lincoln Electric.** This information is provided for reference only. Lincoln Electric discourages board level troubleshooting and repair since it may compromise the quality of the design and may result in danger to the Machine Operator or Technician. Improper PC board repairs could result in damage to the machine.

