

# CLASSIC 300D WIRING DIAGRAM L10877 REV: G

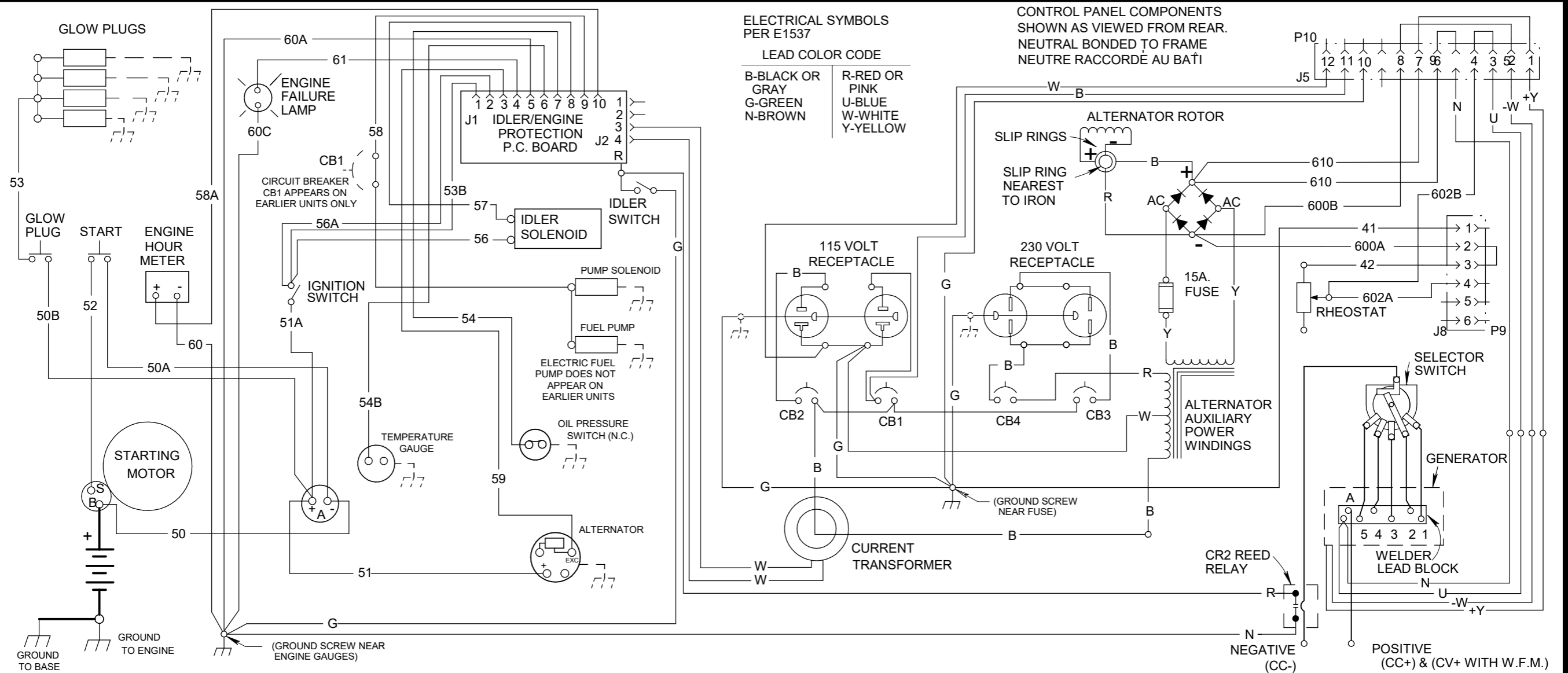

## K924-4 REMOTE CONTROL (OPTIONAL)

### REMOTE CONTROL RECEPTACLE & SWITCH

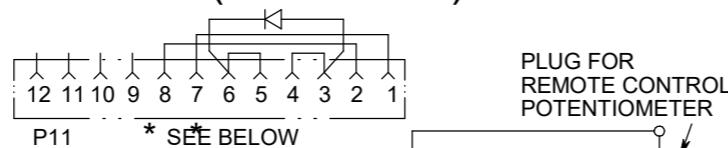
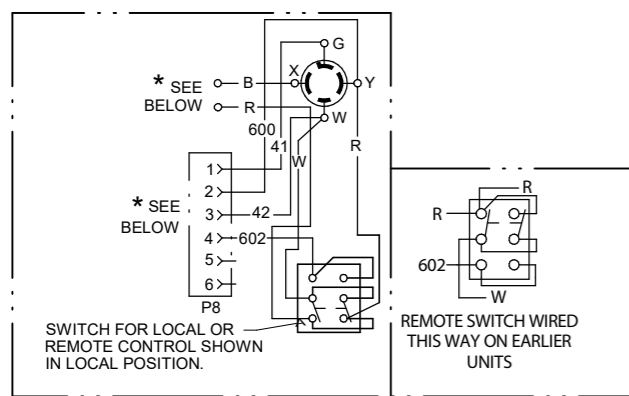

**CAUTION: DAMAGE CAN OCCUR TO THE REMOTE CONTROL SWITCH IF IT IS USED WITHOUT THE "P11" PLUG INSTALLED OR A WIRE FEED MODULE INSTALLED.**

- \* WITH MACHINE NOT RUNNING, REMOVE PLUG "P9" ON MACHINE FROM CONNECTOR "J8". THEN CONNECT PLUG "P8" ON REMOTE CONTROL TO CONNECTOR "J8" ON MACHINE.
- \* IF WIRE FEED MODULE IS INSTALLED, WITH THE MACHINE OFF, DISPOSE OF THE UNCONNECTED PLUG "P10" (IF ONE IS ON THE MACHINE). FASTEN THE NEW PLUG "P11" NEARBY, LEAVING IT UNCONNECTED.
- IF NO WIRE FEED MODULE IS INSTALLED, WITH THE MACHINE OFF, DISCONNECT PLUG "P10" ON THE MACHINE FROM CONNECTOR "J5". CONNECT PLUG "P11" FROM THE REMOTE CONTROL KIT TO CONNECTOR "J5" ON THE MACHINE.
- THE RED AND BLACK LEADS ARE USED ON CLASSIC I MACHINES ONLY AND ARE NOT CONNECTED ON THIS MACHINE. DAMAGE TO THE REMOTE CONTROL AND/OR MACHINE WILL RESULT IF THE RED AND BLACK LEADS ARE CONNECTED IN THE CLASSIC 300D.

## WIRE FEED MODULE (OPTIONAL)

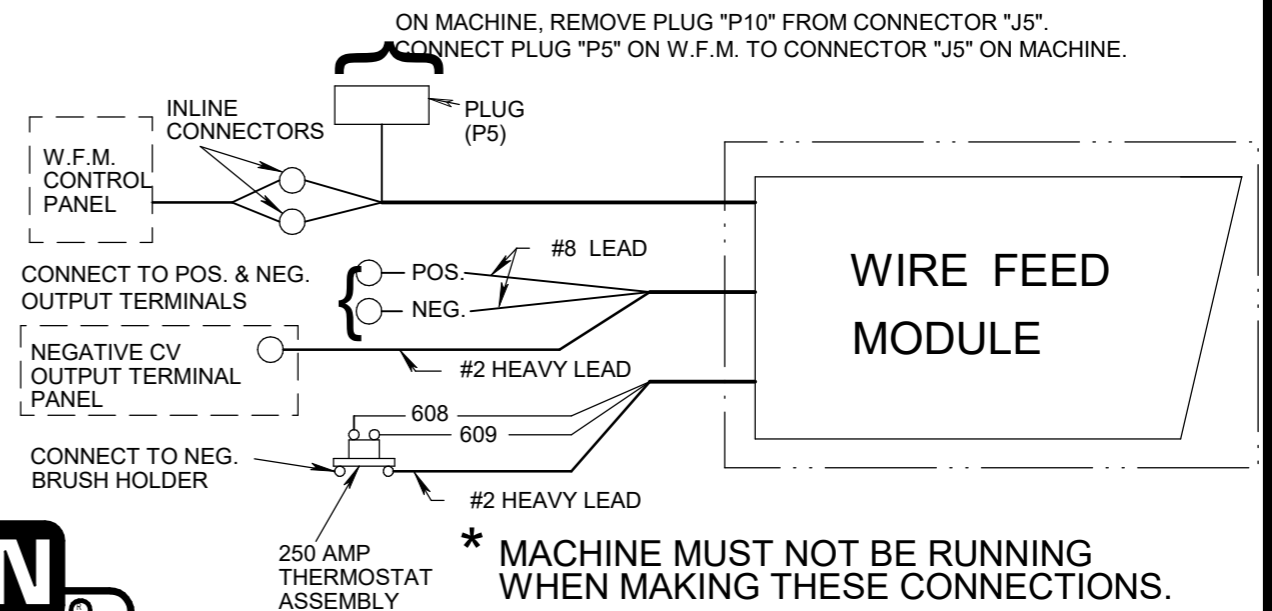

**\* MACHINE MUST NOT BE RUNNING WHEN MAKING THESE CONNECTIONS.**

