

Operator's Manual

Power MIG[®] 350MP

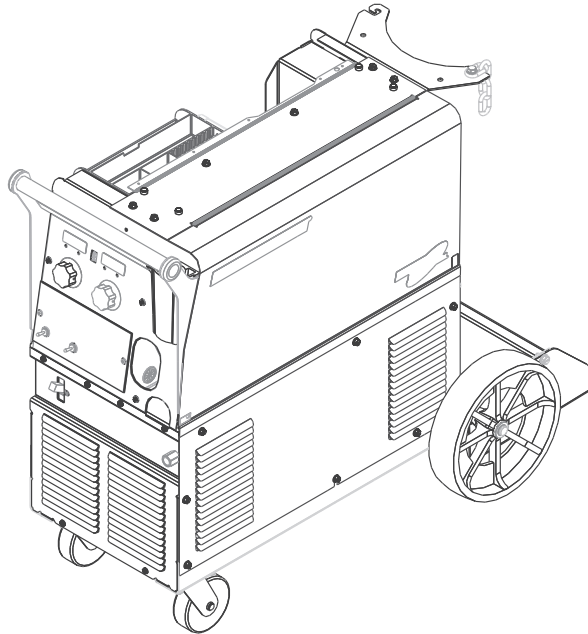

For use with machines having Code Numbers:
11827, 12875



Register your machine:

www.lincolnelectric.com/register

Authorized Service and Distributor Locator:

www.lincolnelectric.com/locator

Save for future reference

Date Purchased

Code: (ex: 10859)

Serial: (ex: U1060512345)

THANK YOU FOR SELECTING A QUALITY PRODUCT BY LINCOLN ELECTRIC.

PLEASE EXAMINE CARTON AND EQUIPMENT FOR DAMAGE IMMEDIATELY

When this equipment is shipped, title passes to the purchaser upon receipt by the carrier. Consequently, claims for material damaged in shipment must be made by the purchaser against the transportation company at the time the shipment is received.

SAFETY DEPENDS ON YOU

Lincoln arc welding and cutting equipment is designed and built with safety in mind. However, your overall safety can be increased by proper installation ... and thoughtful operation on your part. **DO NOT INSTALL, OPERATE OR REPAIR THIS EQUIPMENT WITHOUT READING THIS MANUAL AND THE SAFETY PRECAUTIONS CONTAINED THROUGHOUT.** And, most importantly, think before you act and be careful.

WARNING

This statement appears where the information must be followed exactly to avoid serious personal injury or loss of life.

CAUTION

This statement appears where the information must be followed to avoid minor personal injury or damage to this equipment.



KEEP YOUR HEAD OUT OF THE FUMES.

DON'T get too close to the arc. Use corrective lenses if necessary to stay a reasonable distance away from the arc.

READ and obey the Safety Data Sheet (SDS) and the warning label that appears on all containers of welding materials.

USE ENOUGH VENTILATION or exhaust at the arc, or both, to keep the fumes and gases from your breathing zone and the general area.

IN A LARGE ROOM OR OUTDOORS, natural ventilation may be adequate if you keep your head out of the fumes (See below).

USE NATURAL DRAFTS or fans to keep the fumes away from your face.

If you develop unusual symptoms, see your supervisor. Perhaps the welding atmosphere and ventilation system should be checked.

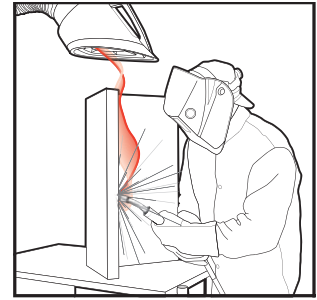

WEAR CORRECT EYE, EAR & BODY PROTECTION

PROTECT your eyes and face with welding helmet properly fitted and with proper grade of filter plate (See ANSI Z49.1).

PROTECT your body from welding spatter and arc flash with protective clothing including woolen clothing, flame-proof apron and gloves, leather leggings, and high boots.

PROTECT others from splatter, flash, and glare with protective screens or barriers.

IN SOME AREAS, protection from noise may be appropriate.

BE SURE protective equipment is in good condition.

Also, wear safety glasses in work area **AT ALL TIMES.**



SPECIAL SITUATIONS

DO NOT WELD OR CUT containers or materials which previously had been in contact with hazardous substances unless they are properly cleaned. This is extremely dangerous.

DO NOT WELD OR CUT painted or plated parts unless special precautions with ventilation have been taken. They can release highly toxic fumes or gases.

Additional precautionary measures

PROTECT compressed gas cylinders from excessive heat, mechanical shocks, and arcs; fasten cylinders so they cannot fall.

BE SURE cylinders are never grounded or part of an electrical circuit.

REMOVE all potential fire hazards from welding area.

ALWAYS HAVE FIRE FIGHTING EQUIPMENT READY FOR IMMEDIATE USE AND KNOW HOW TO USE IT.



SECTION A: WARNINGS



CALIFORNIA PROPOSITION 65 WARNINGS



WARNING: Breathing diesel engine exhaust exposes you to chemicals known to the State of California to cause cancer and birth defects, or other reproductive harm.

- Always start and operate the engine in a well-ventilated area.
- If in an exposed area, vent the exhaust to the outside.
- Do not modify or tamper with the exhaust system.
- Do not idle the engine except as necessary.

For more information go to www.P65warnings.ca.gov/diesel

WARNING: This product, when used for welding or cutting, produces fumes or gases which contain chemicals known to the State of California to cause birth defects and, in some cases, cancer. (California Health & Safety Code § 25249.5 *et seq.*)



WARNING: Cancer and Reproductive Harm
www.P65warnings.ca.gov

ARC WELDING CAN BE HAZARDOUS. PROTECT YOURSELF AND OTHERS FROM POSSIBLE SERIOUS INJURY OR DEATH. KEEP CHILDREN AWAY. PACEMAKER WEARERS SHOULD CONSULT WITH THEIR DOCTOR BEFORE OPERATING.

Read and understand the following safety highlights. For additional safety information, it is strongly recommended that you purchase a copy of "Safety in Welding & Cutting - ANSI Standard Z49.1" from the American Welding Society, P.O. Box 351040, Miami, Florida 33135 or CSA Standard W117.2-1974. A Free copy of "Arc Welding Safety" booklet E205 is available from the Lincoln Electric Company, 22801 St. Clair Avenue, Cleveland, Ohio 44117-1199.

BE SURE THAT ALL INSTALLATION, OPERATION, MAINTENANCE AND REPAIR PROCEDURES ARE PERFORMED ONLY BY QUALIFIED INDIVIDUALS.



FOR ENGINE POWERED EQUIPMENT.

- Turn the engine off before troubleshooting and maintenance work unless the maintenance work requires it to be running.
- Operate engines in open, well-ventilated areas or vent the engine exhaust fumes outdoors.
- Do not add the fuel near an open flame welding arc or when the engine is running. Stop the engine and allow it to cool before refueling to prevent spilled fuel from vaporizing on contact



with hot engine parts and igniting. Do not spill fuel when filling tank. If fuel is spilled, wipe it up and do not start engine until fumes have been eliminated.

- Keep all equipment safety guards, covers and devices in position and in good repair. Keep hands, hair, clothing and tools away from V-belts, gears, fans and all other moving parts when starting, operating or repairing equipment.
- In some cases it may be necessary to remove safety guards to perform required maintenance. Remove guards only when necessary and replace them when the maintenance requiring their removal is complete. Always use the greatest care when working near moving parts.
- Do not put your hands near the engine fan. Do not attempt to override the governor or idler by pushing on the throttle control rods while the engine is running.
- To prevent accidentally starting gasoline engines while turning the engine or welding generator during maintenance work, disconnect the spark plug wires, distributor cap or magneto wire as appropriate.
- To avoid scalding, do not remove the radiator pressure cap when the engine is hot.



ELECTRIC AND MAGNETIC FIELDS MAY BE DANGEROUS



- Electric current flowing through any conductor causes localized Electric and Magnetic Fields (EMF). Welding current creates EMF fields around welding cables and welding machines
- EMF fields may interfere with some pacemakers, and welders having a pacemaker should consult their physician before welding.
- Exposure to EMF fields in welding may have other health effects which are now not known.
- All welders should use the following procedures in order to minimize exposure to EMF fields from the welding circuit:
 - Route the electrode and work cables together - Secure them with tape when possible.
 - Never coil the electrode lead around your body.
 - Do not place your body between the electrode and work cables. If the electrode cable is on your right side, the work cable should also be on your right side.
 - Connect the work cable to the workpiece as close as possible to the area being welded.
 - Do not work next to welding power source.



ELECTRIC SHOCK CAN KILL.



- 3.a. The electrode and work (or ground) circuits are electrically “hot” when the welder is on. Do not touch these “hot” parts with your bare skin or wet clothing. Wear dry, hole-free gloves to insulate hands.
- 3.b. Insulate yourself from work and ground using dry insulation. Make certain the insulation is large enough to cover your full area of physical contact with work and ground.

In addition to the normal safety precautions, if welding must be performed under electrically hazardous conditions (in damp locations or while wearing wet clothing; on metal structures such as floors, gratings or scaffolds; when in cramped positions such as sitting, kneeling or lying, if there is a high risk of unavoidable or accidental contact with the workpiece or ground) use the following equipment:

- Semiautomatic DC Constant Voltage (Wire) Welder.
 - DC Manual (Stick) Welder.
 - AC Welder with Reduced Voltage Control.
- 3.c. In semiautomatic or automatic wire welding, the electrode, electrode reel, welding head, nozzle or semiautomatic welding gun are also electrically “hot”.
 - 3.d. Always be sure the work cable makes a good electrical connection with the metal being welded. The connection should be as close as possible to the area being welded.
 - 3.e. Ground the work or metal to be welded to a good electrical (earth) ground.
 - 3.f. Maintain the electrode holder, work clamp, welding cable and welding machine in good, safe operating condition. Replace damaged insulation.
 - 3.g. Never dip the electrode in water for cooling.
 - 3.h. Never simultaneously touch electrically “hot” parts of electrode holders connected to two welders because voltage between the two can be the total of the open circuit voltage of both welders.
 - 3.i. When working above floor level, use a safety belt to protect yourself from a fall should you get a shock.
 - 3.j. Also see Items 6.c. and 8.



ARC RAYS CAN BURN.



- 4.a. Use a shield with the proper filter and cover plates to protect your eyes from sparks and the rays of the arc when welding or observing open arc welding. Headshield and filter lens should conform to ANSI Z87.1 standards.
- 4.b. Use suitable clothing made from durable flame-resistant material to protect your skin and that of your helpers from the arc rays.
- 4.c. Protect other nearby personnel with suitable, non-flammable screening and/or warn them not to watch the arc nor expose themselves to the arc rays or to hot spatter or metal.



FUMES AND GASES CAN BE DANGEROUS.



- 5.a. Welding may produce fumes and gases hazardous to health. Avoid breathing these fumes and gases. When welding, keep your head out of the fume. Use enough ventilation and/or exhaust at the arc to keep fumes and gases away from the breathing zone. **When welding hardfacing (see instructions on container or SDS) or on lead or cadmium plated steel and other metals or coatings which produce highly toxic fumes, keep exposure as low as possible and within applicable OSHA PEL and ACGIH TLV limits using local exhaust or mechanical ventilation unless exposure assessments indicate otherwise. In confined spaces or in some circumstances, outdoors, a respirator may also be required. Additional precautions are also required when welding on galvanized steel.**
- 5.b. The operation of welding fume control equipment is affected by various factors including proper use and positioning of the equipment, maintenance of the equipment and the specific welding procedure and application involved. Worker exposure level should be checked upon installation and periodically thereafter to be certain it is within applicable OSHA PEL and ACGIH TLV limits.
- 5.c. Do not weld in locations near chlorinated hydrocarbon vapors coming from degreasing, cleaning or spraying operations. The heat and rays of the arc can react with solvent vapors to form phosgene, a highly toxic gas, and other irritating products.
- 5.d. Shielding gases used for arc welding can displace air and cause injury or death. Always use enough ventilation, especially in confined areas, to insure breathing air is safe.
- 5.e. Read and understand the manufacturer’s instructions for this equipment and the consumables to be used, including the Safety Data Sheet (SDS) and follow your employer’s safety practices. SDS forms are available from your welding distributor or from the manufacturer.
- 5.f. Also see item 1.b.



WELDING AND CUTTING SPARKS CAN CAUSE FIRE OR EXPLOSION.

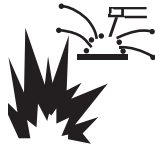

- 6.a. Remove fire hazards from the welding area. If this is not possible, cover them to prevent the welding sparks from starting a fire. Remember that welding sparks and hot materials from welding can easily go through small cracks and openings to adjacent areas. Avoid welding near hydraulic lines. Have a fire extinguisher readily available.
- 6.b. Where compressed gases are to be used at the job site, special precautions should be used to prevent hazardous situations. Refer to "Safety in Welding and Cutting" (ANSI Standard Z49.1) and the operating information for the equipment being used.
- 6.c. When not welding, make certain no part of the electrode circuit is touching the work or ground. Accidental contact can cause overheating and create a fire hazard.
- 6.d. Do not heat, cut or weld tanks, drums or containers until the proper steps have been taken to insure that such procedures will not cause flammable or toxic vapors from substances inside. They can cause an explosion even though they have been "cleaned". For information, purchase "Recommended Safe Practices for the Preparation for Welding and Cutting of Containers and Piping That Have Held Hazardous Substances", AWS F4.1 from the American Welding Society (see address above).
- 6.e. Vent hollow castings or containers before heating, cutting or welding. They may explode.
- 6.f. Sparks and spatter are thrown from the welding arc. Wear oil free protective garments such as leather gloves, heavy shirt, cuffless trousers, high shoes and a cap over your hair. Wear ear plugs when welding out of position or in confined places. Always wear safety glasses with side shields when in a welding area.
- 6.g. Connect the work cable to the work as close to the welding area as practical. Work cables connected to the building framework or other locations away from the welding area increase the possibility of the welding current passing through lifting chains, crane cables or other alternate circuits. This can create fire hazards or overheat lifting chains or cables until they fail.
- 6.h. Also see item 1.c.
- 6.i. Read and follow NFPA 51B "Standard for Fire Prevention During Welding, Cutting and Other Hot Work", available from NFPA, 1 Batterymarch Park, PO box 9101, Quincy, MA 022690-9101.
- 6.j. Do not use a welding power source for pipe thawing.



CYLINDER MAY EXPLODE IF DAMAGED.



- 7.a. Use only compressed gas cylinders containing the correct shielding gas for the process used and properly operating regulators designed for the gas and pressure used. All hoses, fittings, etc. should be suitable for the application and maintained in good condition.
- 7.b. Always keep cylinders in an upright position securely chained to an undercarriage or fixed support.
- 7.c. Cylinders should be located:
 - Away from areas where they may be struck or subjected to physical damage.
 - A safe distance from arc welding or cutting operations and any other source of heat, sparks, or flame.
- 7.d. Never allow the electrode, electrode holder or any other electrically "hot" parts to touch a cylinder.
- 7.e. Keep your head and face away from the cylinder valve outlet when opening the cylinder valve.
- 7.f. Valve protection caps should always be in place and hand tight except when the cylinder is in use or connected for use.
- 7.g. Read and follow the instructions on compressed gas cylinders, associated equipment, and CGA publication P-1, "Precautions for Safe Handling of Compressed Gases in Cylinders," available from the Compressed Gas Association, 14501 George Carter Way Chantilly, VA 20151.



FOR ELECTRICALLY POWERED EQUIPMENT.



- 8.a. Turn off input power using the disconnect switch at the fuse box before working on the equipment.
- 8.b. Install equipment in accordance with the U.S. National Electrical Code, all local codes and the manufacturer's recommendations.
- 8.c. Ground the equipment in accordance with the U.S. National Electrical Code and the manufacturer's recommendations.

Refer to
<http://www.lincolnelectric.com/safety>
for additional safety information.

Installation	Section A
Technical Specifications	A-1
Safety Precautions	A-2
Uncrating the POWER MIG® 350MP	A-2
Location	A-2
Input Power, Grounding and Connection Diagrams	A-2, A-3
Gun and Cable Installation	A-4
Shielding Gas	A-4 thru A-5
Installing TIG Torch	A-5, A-6
Operation	Section B
Safety Precautions	B-1
Definition Of Welding Modes	B-1
Common Welding Abbreviations	B-1
Product Description	B-2
Controls and Settings	B-2, B-3
Setting and Configuring the POWER MIG® 350MP for welding	B-4
Multi-Process Panel Functions	B-5, B-6
Wire Drive Roll	B-7
Procedure for Changing Drive and Idle Roll Sets.....	B-8
Wire Reel Loading.....	B-8
Mounting of 10 to 44 lbs. Spools	B-8
Feeding Wire Electrode.....	B-9
Idle Roll Pressure Setting.....	B-9
Wire Drive Configuration.....	B-9, B-10
Avoiding Wire Feeding Problems	B-10
Special Welding Processes Available	B-11
Pulse On Pulse, and Benefits of Pulse On Pulse.....	B-12
Power Mode, TIG Welding	B-13
Accessories	Section C
Drive Roll Kits.....	C-1
Aluminum Feeding Kit, Readi-Reel Adapter	C-1
Dual Cylinder Mounting Kit.....	C-1
Magnum GMAW Gun and Cable Assemblies	C-1
Magnum Gun Connection Kit	C-1
Spool Gun Prince™ XL	C-1
Making a Weld with the Prince XL or Cobra Gold Torch Installed	C-2
Maintenance	Section D
Safety Precautions, General Maintenance.....	D-1
Drive Rolls and Guide Plates	D-1
Contact Tip and Gas Nozzle Installation	D-1
Gun Tubes and Nozzles, Gun Cable Cleaning	D-1
Liner Removal and Replacement.....	D-2
Push/Pull Gun Calibration	D-3
Checking Gun Calibration	D-3
Gun Calibration Procedure.....	D-3
Troubleshooting	Section E
How to Use Troubleshooting Guide	E-1
Troubleshooting	E-2 thru E-5
Fault Codes	E-6
Push / Pull Gun Wire Feeder Troubleshooting	E-7 thru E-10
Diagrams	Section F
Wiring Diagrams and Dimension Print	F-1, F-2

Parts List parts.lincolnelectric.com

Content/details may be changed or updated without notice. For most current Instruction Manuals, go to parts.lincolnelectric.com.

TECHNICAL SPECIFICATIONS – POWER MIG® 350MP

INPUT – SINGLE PHASE ONLY					
Standard Voltage/Frequency 208/230/460/575/50/60 Hz		Input Current @ 230Amp Rated Output 50/48/25/20 Amps		Input Current @ 300 Amp Rated Output 76/64/37/29 Amps	
RATED OUTPUT					
Input Voltage/Frequency Hz	Duty Cycle	Amps		Volts at Rated Amperes	
208/60	40%	300 Amps		32 Volts	
230/460/575/60	60%	300 Amps		32 Volts	
208/230/460/575/60	100%	230 Amps		29 Volts	
208/230/460/575/50	40%	300 Amps		32 Volts	
208/230/460/575/50	100%	230 Amps		29 Volts	
OUTPUT					
Welding Current Range (Continuous) 5 – 350 Amps		Maximum Open Circuit Voltage 67 Volts		Welding Voltage Range 10-45 Volts	
RECOMMENDED INPUT WIRE AND FUSE SIZES - SINGLE PHASE					
Input Voltage/ Frequency (Hz)	230Amps @ 29 Volts (100% Duty Cycle)	300Amps @ 32 Volts (60% Duty Cycle)	350Amps @ 34 Volts (40% Duty Cycle)	75°C Copper AWG (IEC) Sizes (MM ²)	Wire Fuse or Breaker Size
208/50*/60**	50A	76A	93A	6 (16 mm ²)	100 A
230/50*/60	48A	64A	80A	6 (16 mm ²)	80 A
460/50*/60	25A	37A	45A	10 (6 mm ²)	50 A
575/50*/60	20A	29A	34A	12 (2.5 mm ²)	35 A

Wire the Welder to Dedicated circuit branch.
NOTE: Use #10 AWG Grounding Wire.
*For 50Hz operation: The duty Cycle Rating at 300 Amps is 40%. The duty cycle rating at 350 Amps is 30%.
**For 208V Input: The duty Cycle Rating at 300 Amps is 40%.

PHYSICAL DIMENSIONS			
Height	Width	Depth	Weight
31.79 in	18.88 in	38.78 in	255 lbs
808 mm	480 mm	985 mm	116 kg

WIRE SPEED RANGE	
Wire Speed	50 – 700 IPM (1.27 – 17.8 m/minute)

DUTY CYCLE GRAPH

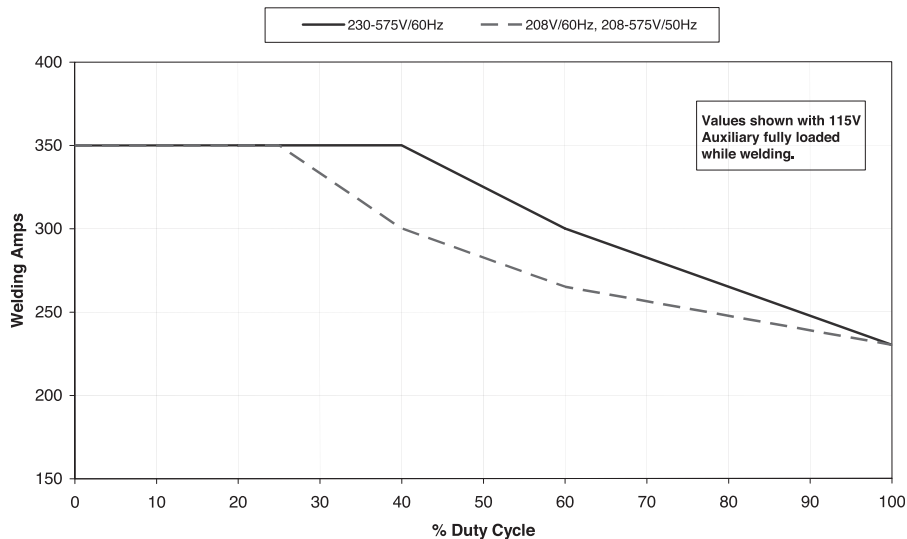

Read entire installation section before starting installation.

SAFETY PRECAUTIONS

WARNING



ELECTRIC SHOCK can kill.

- Do not touch electrically live parts or electrode with skin or wet clothing.
- Insulate yourself from work and ground.
- Always wear dry insulating gloves.
- Do not use AC welder if your clothing, clothes or work area is damp or if working on, under or inside work piece.

Use the following equipment:

- Semiautomatic DC constant voltage (wire) welder.
- DC manual (stick) welder.
- AC welder with reduced voltage control.
- Do not operate with panels removed.
- Disconnect input power before servicing.



FUMES AND GASES can be dangerous.

- Keep your head out of fumes.
- Use ventilation or exhaust to remove fumes from breathing zone and general area.



WELDING SPARKS can cause fire or explosion.

- Keep flammable material away.
- Do not weld on closed containers.

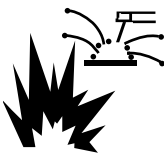

ARC RAYS can burn eyes and skin.

- Wear eye, ear and body protection.



Observe all safety information throughout this manual.

ONLY QUALIFIED PERSONNEL SHOULD INSTALL, USE OR SERVICE THIS EQUIPMENT.

UNCRATING THE POWER MIG® 350MP

Cut banding and lift off cardboard carton. Cut banding holding the machine to the skid. Remove foam and corrugated packing material. Untape accessories from Gas Bottle Platform. Unscrew the two wood screws (at the Gas Bottle Platform) holding the machine to the skid. Roll the machine off the skid assembly.

LOCATION

Locate the welder in a dry location where there is free circulation of clean air into the louvers in the back and out the front. A location that minimizes the amount of smoke and dirt drawn into the rear louvers reduces the chance of dirt accumulation that can block air passages and cause overheating.

INPUT POWER, GROUNDING AND CONNECTION DIAGRAMS

1. Before starting the installation, check with the local power company if there is any question about whether your power supply is adequate for the voltage, amperes, phase, and frequency specified on the welder nameplate. Also be sure the planned installation will meet the U.S. National Electrical Code and local code requirements. This welder may be operated from a single phase line or from one phase of a two or three phase line.
2. The POWER MIG® 350MP is supplied connected for 230 Volt Input. If the welder is to be operated on another voltage, it must be reconnected according to the instructions in Figure A.1

FIGURE A.1 — Triple Voltage Machine Input Connections

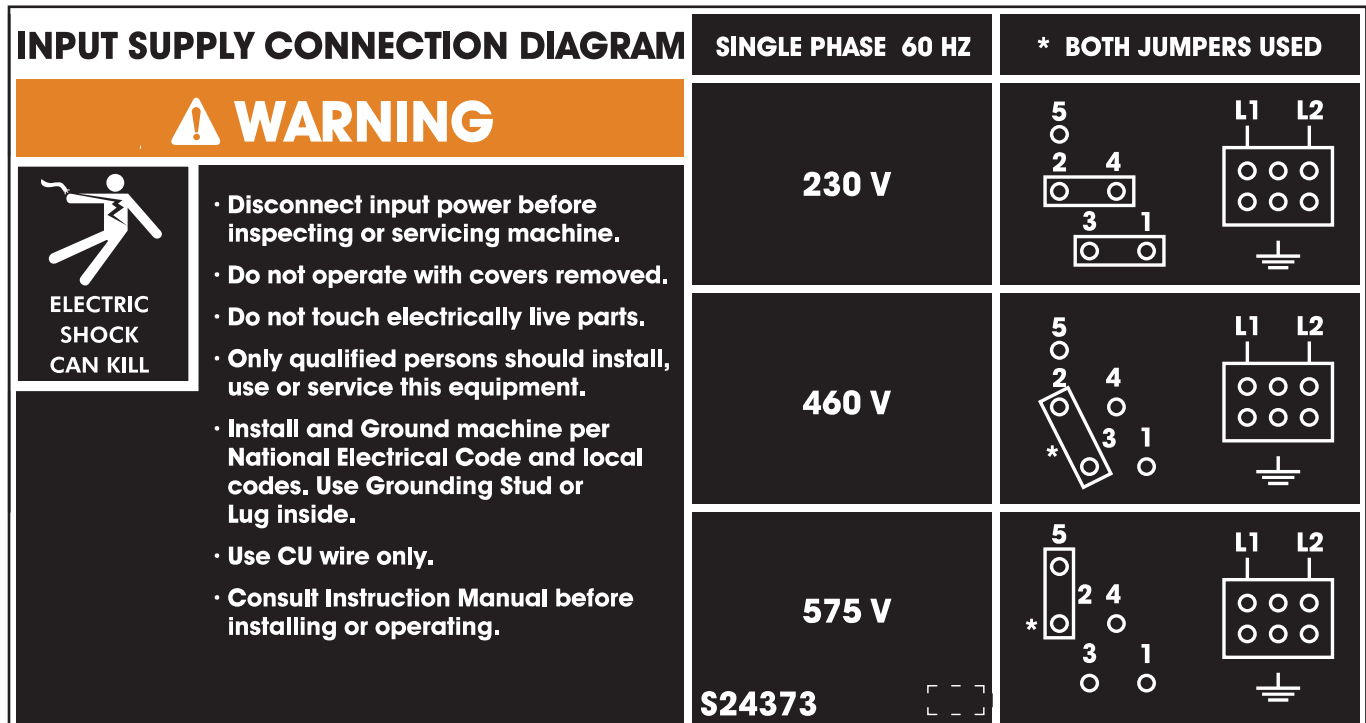

3. The POWER MIG® 350MP is shipped with a 10ft.(3.05m) input cable and plug connected to the welder. Using the instructions in Figure A.2, have a qualified electrician connect the receptacle or cable to the input power lines and the system ground per the U.S. National Electrical Code and any applicable local codes. See “Technical Specifications” at the beginning of this chapter for proper wire sizes. For long runs over 100ft. (30.48m), larger copper wires should be used. Fuse the two hot lines with super lag type fuses as shown in the following diagram. The center contact in the receptacle is for the grounding connection. A green wire in the input cable connects this contact to the frame of the welder. This ensures proper grounding of the welder frame when the welder plug is inserted into the receptacle.

For input voltages above 230V, remove 208/230V input cord supplied and replace with direct hard wire connection to the fuse box.

For 208V Canadian installations, remove the plug and connect directly to the fuse box in accordance with the Canadian Electric Code.

AUXILIARY POWER RECEPTACLES

(15 Amp, 120 Volt Receptacle) The receptacle is UL and CSA approved.

FIGURE A.2 — Receptacle Diagram

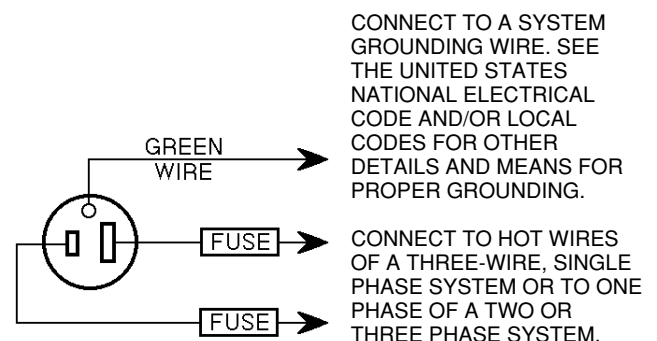

GUN AND CABLE INSTALLATION

A Magnum 300 gun and 15Ft.(4.6m) cable are provided with the POWER MIG® 350MP. A Magnum cable liner for .035-.045" (0.9-1.2 mm) electrode and contact tips for .035" (0.9mm) and .045" (1.2mm) are included for 15Ft..

⚠ WARNING

Turn the welder power switch off before installing gun and cable.

LINER INSTALLATION AND TRIMMING INSTRUCTION (SEE FIGURE A.3)

1. Remove the gas nozzle.
2. Remove the gas diffuser from the gun tube.
3. Lay gun and cable out straight on a flat surface. Loosen set screw of the connector on the back end of the gun.
4. Insert the untrimmed Liner into the back end of the gun.
5. Seat Liner bushing into back of gun. Secure Liner by tightening set screw. Do not install the gas diffuser at this time.
6. Lay the cable straight and trim Liner to 9/16". Remove burrs.
7. Install insulator and secure the gas diffuser into the tube.

GUN & CABLE ASSEMBLY INSTALLED INTO THE POWER MIG®

1. Unscrew knurled screw on the drive unit front end (inside wire feed compartment) until tip of screw no longer protrudes into gun opening as seen

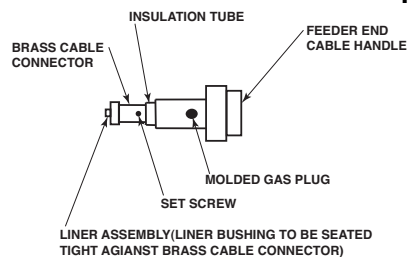
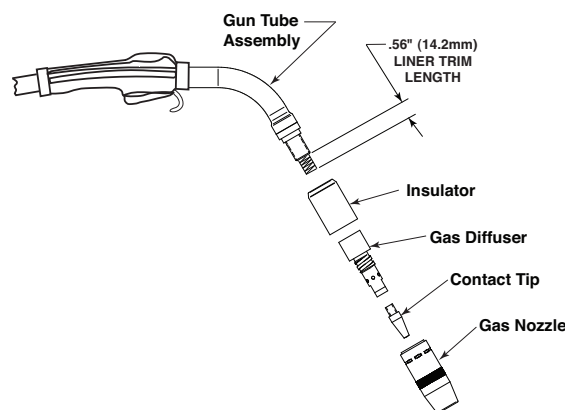

FIGURE A.3



from front of machine.

2. Insert the male end of gun cable into the female casting through opening in front panel. Make sure connector is fully inserted and tighten knurled screw.
3. Connect the gun trigger connector from the gun and cable to the mating receptacle inside the compartment located above the gun connection made in step 2 above. Make sure that the key ways are aligned, insert and tighten retaining ring.

SHIELDING GAS

(For Gas Metal Arc Welding Processes)

Customer must provide cylinder of appropriate type shielding gas for the process being used.

A gas flow regulator, for CO₂ or Argon blend gas, and an inlet gas hose are factory provided with the POWER MIG® 350MP.

⚠ WARNING

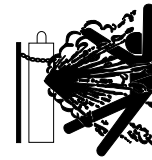

CYLINDER may explode if damaged.

• Gas under pressure is explosive. Always keep gas cylinders in an upright position and always keep chained to undercarriage or stationary support. See American National Standard Z-49.1, "Safety in Welding and Cutting" published by the American Welding Society.

Install shielding gas supply as follows:

1. Set gas cylinder on rear platform of POWER MIG® 350MP. Hook chain in place to secure cylinder to rear of welder.
2. Remove the cylinder cap. Inspect the cylinder valves and regulator for damaged threads, dirt, dust, oil or grease. Remove dust and dirt with a

DO NOT ATTACH THE REGULATOR IF OIL, GREASE OR DAMAGE IS PRESENT! Inform your gas supplier of this condition. Oil or grease in the presence of high pressure oxygen is explosive.

- Stand to one side away from the outlet and open the cylinder valve for an instant. This blows away any dust or dirt which may have accumulated in the valve outlet.

WARNING

Be sure to keep your face away from the valve outlet when “cracking” the valve.

- Attach the flow regulator to the cylinder valve and tighten the union nut(s) securely with a wrench.

NOTE: If connecting to 100% CO₂ cylinder, insert regulator adapter between regulator and cylinder valve. If adapter is equipped with a plastic washer, be sure it is seated for connection to the CO₂ cylinder.

- Attach one end of the inlet gas hose to the outlet fitting of the flow regulator, the other end to the POWER MIG® 350MP rear fitting, and tighten the union nuts securely with a wrench.
- Before opening the cylinder valve, turn the regulator adjusting knob counterclockwise until the adjusting spring pressure is released.
- Standing to one side, open the cylinder valve slowly a fraction of a turn. When the cylinder pressure gauge pointer stops moving, open the valve fully.

WARNING

Never stand directly in front of or behind the flow regulator when opening the cylinder valve. Always stand to one side.

- The flow regulator is adjustable. Adjust it to the flow rate recommended for the procedure and process being used before making the weld.

INSTALLING TIG TORCH

The POWER MIG® 350MP is programmed to allow it to be used as a DC TIG welder. The following information addresses the installation of an air-cooled TIG torch with separate power cable and a separate gas hose (2-cable style).

Connecting TIG Torch:

(See Figure A.4)

WARNING



ELECTRIC SHOCK can kill.

Turn off welder before adding or installing accessory items.

- Tightly secure work lead to positive stud (+).
- Tightly connect the Power cable to Negative stud (-).
- Connect the gas supply line to the connector on the front of the machine.
- After following the previous instructions of installing the cylinder and regulator, locate gas connection on the back of the machine which is marked **Spool GUN or TIG Torch** and connect gas line from Cylinder and Regulator as shown in Figure A.5.
- Connect the remote control receptacle from the Foot Amptrol(Optional) to the remote control receptacle on the machine.

FIGURE A.4

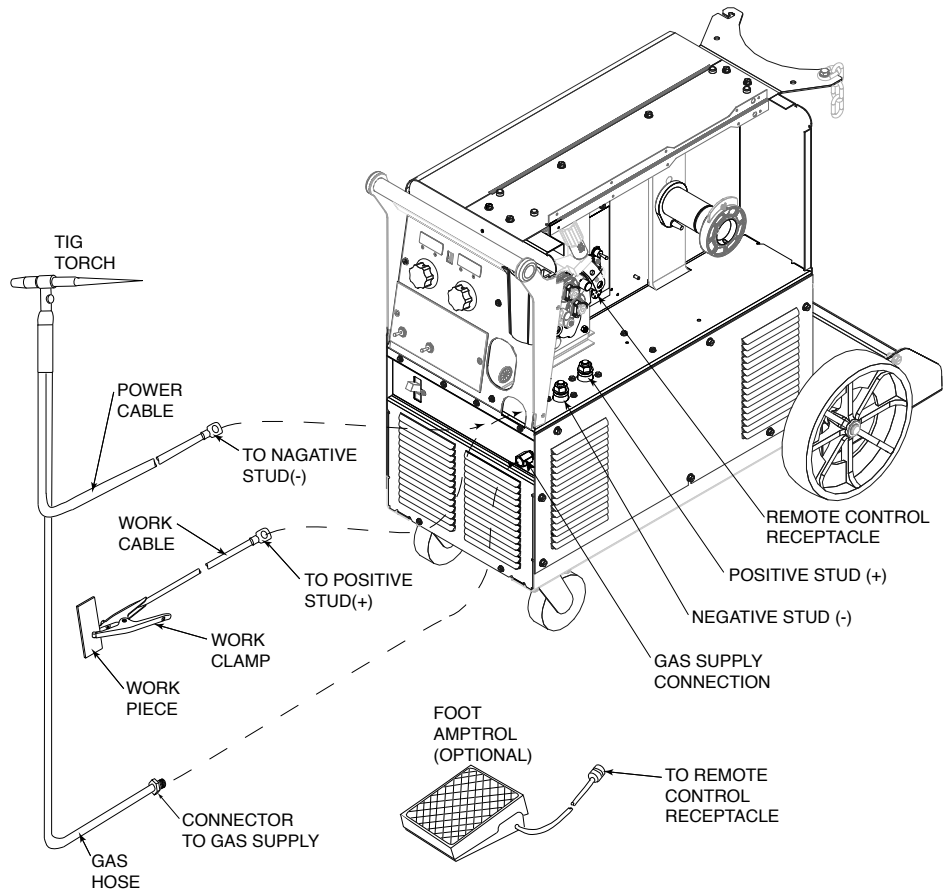
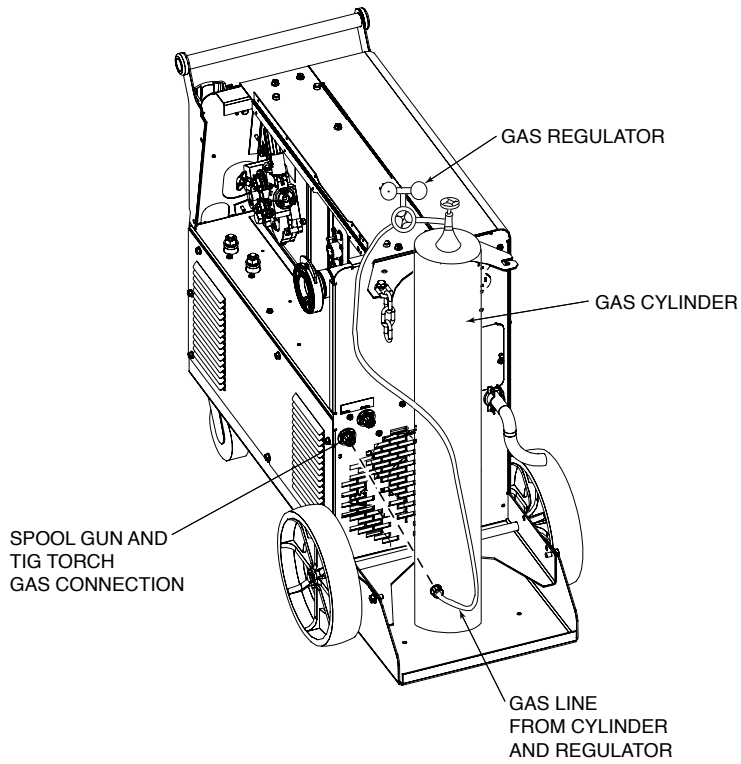

FIGURE A.5



Read entire Operation section before operating the POWER MIG® 350MP.

⚠ WARNING



ELECTRIC SHOCK can kill.

- Do not touch electrically live parts or electrode with skin or wet clothing. Insulate yourself from work and ground.
- Always wear dry insulating gloves.



FUMES AND GASES can be dangerous.

- Keep your head out of fumes.
- Use ventilation or exhaust to remove fumes from breathing zone.



WELDING SPARKS can cause fire or explosion.

- Keep flammable material away.
- Do not weld on closed containers.



ARC RAYS can burn eyes and skin.

- Wear eye, ear and body protection.

Observe all safety information throughout this manual.

DEFINITIONS OF WELDING MODES

NON-SYNERGIC WELDING MODES

- A **Non-synergic** welding mode requires all welding process variables to be set by the operator.

SYNERGIC WELDING MODES

- A **Synergic** welding mode offers the simplicity of single knob control. The machine will select the correct voltage and amperage based on the wire feed speed (WFS) set by the operator.

COMMON WELDING ABBREVIATIONS

WFS

- Wire Feed Speed

CC

- Constant Current

CV

- Constant Voltage

GMAW (MIG)

- Gas Metal Arc welding

GMAW-P (MIG)

- Gas Metal Arc welding-(Pulse)

GMAW-PP (MIG)

- Gas Metal Arc welding-(Pulse-on-Pulse)

GTAW (TIG)

- Gas Tungsten Arc welding

SMAW (STICK)

- Shielded Metal Arc welding

FCAW (INNERSHIELD)

- Flux Core Arc Welding

PRODUCT DESCRIPTION

The POWER MIG® 350MP is a complete semiautomatic multi-process DC arc welding machine offering CV and CC DC welding. It is rated for 350 amps, 32 volts at a 60% duty cycle. The standard machine is equipped to weld CC-Stick, CC-GTAW, CV-FCAW, and synergic and non-synergic CV-GMAW / GMAW-P and Pulse-on-Pulse and Power Mode welding processes. See the descriptions for Pulse™ and Power Mode welding processes later in this section.

Mode #5 and mode #6 are non-synergic CV GMAW modes for bare and flux cored wires, respectively. In these modes, the user presets the wire feed speed (WFS) on the left meter and the welding voltage on the right. These two settings are independent; that is, if the WFS is changed the voltage will remain constant, or vice versa.

All of the other mode numbers designated as "CV" are synergic. Again, WFS is shown on the left meter and voltage is shown on the right meter. However, in using these modes, the WFS is preset and the voltage is preset only once. Now, when the WFS is changed, the voltage will change with it, so that the arc appearance and arc length will stay the same without the necessity to re-adjust the voltage.

The modes shown as "GMAW-P" or "GMAW-PP" are all synergic pulsed modes. In these modes WFS is shown on the left meter and "Trim" is shown on the right meter. The user adjusts WFS to obtain an arc with the correct arc energy for the material thickness being welded. The Trim, which is adjustable from values of 0.5 to 1.5, 1.00(Nominal) and up to 1.5 controls the arc length. Higher values of Trim give longer arc lengths. Once the user has adjusted the Trim for one WFS, the power supply will synergically change many variables so that, as the WFS is changed, the arc length and arc appearance will remain the same. The synergic modes are usable with both push and push – pull torches, as described later in this Manual. When using a spool gun, however, although the synergic pulsed modes are still accessible, they must be used in a non-synergic manner as described in the Accessory Section.

The digital microcomputer based control system allows easy and accurate adjustment of weld parameters through the multi-process panel located on the front of the machine. The POWER MIG® 350MP is equipped with a 6-pin and 7-pin connector to allow operation of a push-pull gun for feeding aluminum wires, a spool gun, remotes, and a foot amptrol.

Other features

Optional kits are available for push-pull welding, spool gun operation, push feeding of 3/64 aluminum with the standard POWER MIG® 350MP gun and wire feeder. A Dual Cylinder Mounting Kit is also offered.

CONTROLS AND SETTINGS

(See Figure B.1)

1. WIRE FEED SPEED (WFS) / AMP METER - This meter displays either the WFS or current value (Amps) depending on the status of the machine. Located below the display is the text "WFS" and "Amps." An LED light is illuminated to the left of one of these units to indicate the units of the value displayed on the meter.

- Prior to CV operation, the meter displays the desired preset WFS value.
- Prior to CC-Stick and CC-GTAW operation, the meter displays the preset current value.
- During Welding, the meter displays actual average amps.
- After welding, the meter holds the actual current value for 5 seconds. During this time, the display is blinking to indicate that the machine is in the "Hold" period. Output adjustment while in the "Hold" period results in the "prior to operation" characteristics stated above.
- After the 5 second "Hold" period, the meter displays the set WFS (CV modes) or Amp (CC modes) value.

Figure B.1

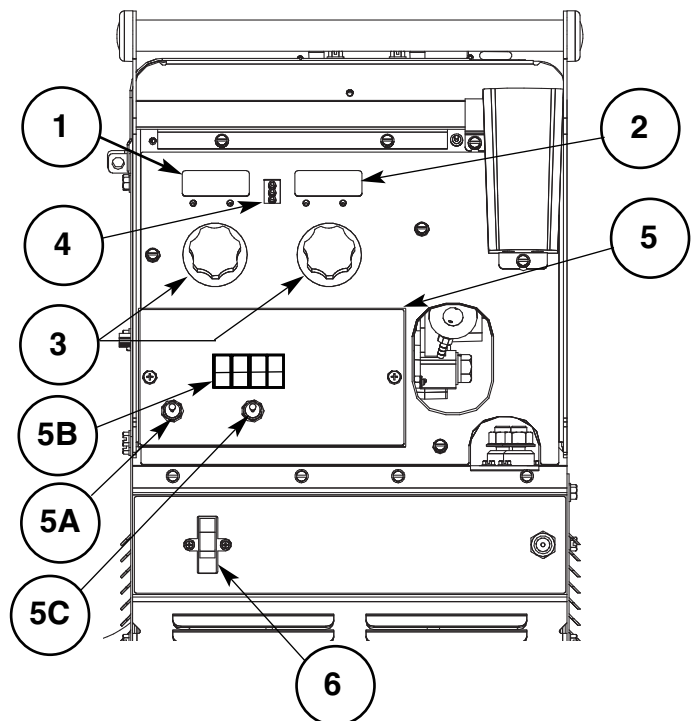

2. VOLT / TRIM METER - This meter displays either the voltage or trim value depending on the status of the machine. Located below the display is the text "Volts" and "Trim." An LED light is illuminated to the left of one of these in order to indicate the units of the value displayed in the meter.

CV Processes

- Prior to GMAW and FCAW operation, the meter displays the desired preset Voltage value.
- Prior to synergic GMAW-P and GMAW-PP operation, the meter displays the desired preset Trim value. Trim adjusts the synergic default voltage as a percentage of that voltage. A trim value of 1 is the default and results in the recommended voltage setting for a given wire feed speed. Adjusting trim to a value of .95, adjusts the voltage to 95% of the recommended voltage.
- During Welding, the meter displays actual average volts.
- After welding, the meter holds the actual voltage value for 5 seconds. During this time, the display is blinking to indicate that the machine is in the "Hold" period. Output adjustment while in the "Hold" period results in the "prior to operation" characteristics stated above.
- After the 5 second "Hold" period, the meter displays the set Voltage (GMAW, FCAW) or Trim (GMAW-P) value.

CC Processes

- The meter displays the status of the output.
- When output is enabled, the meter will display "ON."
- When there is no output, the meter will display "OFF."

3. OUTPUT CONTROLS - The POWER MIG® 350MP has 2 encoder knobs to adjust weld parameters.

- Each encoder changes the displayed value of the meter located directly above that encoder.
- In CC-GTAW modes, the left encoder sets the maximum welding current. Full depression of a foot or hand amptrol results in the preset level of current.
- In CC-Stick and CC-GTAW, the right encoder activates and de-activates the output. Turning the encoder clockwise enables the output if not using a remote trigger device. To de-energize the output, turn the encoder counter-clockwise. The display above will indicate the "ON" or "OFF" status of the output.

4. THERMAL - This status light illuminates when the power source has been driven into thermal overload.

5. MULTI-PROCESS PANEL - This panel enables selection of weld modes as well as adjustment of certain weld parameters within each weld mode.

The eight discrete LED's are used to identify which selection will be shown on the display. The possible selections are:

- Weld Mode (Process selection choices)
 - Preflow / Postflow
 - Run-In
 - Start
 - Arc Control
 - Crater
 - Burnback
 - Spot
- } Choice of weld parameters that can be adjusted. Complete descriptions of each parameter are found later in this section.

Only one LED will be illuminated at any time. The Weld Mode attribute will always be a valid selection (the other attributes may not be available in all processes).

5A. SELECT Toggle Switch

- This switch toggles through the 8 selections detailed above the switch.
- A red LED is located next to each possible selection and is illuminated when that choice can be changed.

5B. Display Meter

- This meter displays the active weld mode (a set of weld parameters that have been determined to provide the recommended results for a particular welding process) when the "Weld Mode" LED is illuminated or when any one of the other seven LED's is illuminated the meter indicates what value that welding parameter has been set to.

5C. SET Toggle Switch

- This switch adjusts (up or down) the value shown on the display meter. When the WELD MODE LED is illuminated, this switch is changing the weld mode of the machine. The most commonly used modes are displayed in the chart on the right half of the Multi-Process Panel.

If the LED next to a weld parameter (Preflow/Postflow, Run-In, Start, etc.) is illuminated, the SET switch will adjust the setting of that specific weld parameter. The setting is shown on the display meter.

6. ON/OFF POWER SWITCH

SETTING AND CONFIGURING THE POWER MIG® 350MP FOR WELDING

- Check that the electrode polarity is correct for the process and turn the Power Switch to the "ON" position. After the "boot-up" period (approximately 20 seconds), the POWER MIG® 350MP will default to the last preset weld mode that was active when the machine was powered down. The Multi-Process Panel defaults with the "Weld Mode" active.
- Toggle the SET switch to the desired "Weld Mode" operation. The Multi-Process Meter displays a weld mode number corresponding to a CC or CV welding process as detailed by the chart on the right side of the panel. In the example shown in Figure B.2 "3" is displayed above the SET switch. This means that the machine is set for CC-GTAW (TIG) welding.
- Toggle the SELECT switch to activate the "weld parameters" for the selected weld mode.
- Set each parameter using the SET switch to adjust the parameter displayed on the display meter.

NOTE: If the LED next to the weld parameter is flashing, the WFS/AMP and/or the Volt/Trim values can also be adjusted for that parameter using the control knobs below each display meter. An LED below each of the displays will also be flashing to indicate which value is adjustable.

The Table B.1 shows which weld parameters are adjustable for a given weld mode. The weld parameters are detailed later in this section.

FIGURE B.2

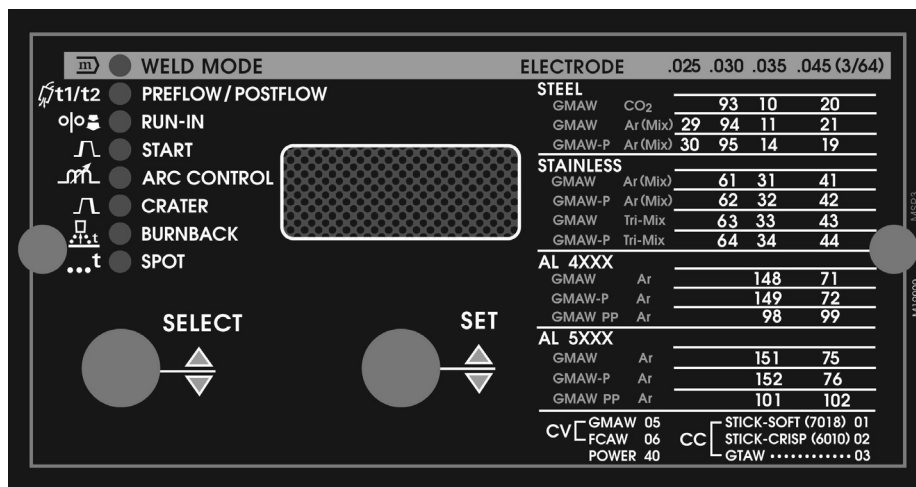

TABLE B.1

	PREFLOW / POSTFLOW	RUN IN	START	ARC CONTROL	CRATER	BURNBACK	SPOT
CC-STICK	----	----	Yes	Yes	----	----	----
CC-GTAW	POSTFLOW	----	Yes	----	----	----	----
CV-FCAW	----	Yes	Yes	Yes	Yes	Yes	Yes
CV-GMAW	Yes	Yes	Yes	Yes	Yes	Yes	Yes
CV-GMAW-P	Yes	Yes	Yes	Yes	Yes	Yes	Yes
POWER	Yes	Yes	Yes	Yes	Yes	Yes	Yes

MULTI-PROCESS PANEL FUNCTIONS

Weld Mode

Setting the Weld Mode is selecting the proper program from the ones available in the machine's memory for a particular welding application. The table on the right side of the front panel (See Figure B.2) gives information on the different programs available in this machine. It describes the type of process (CV, CC, synergic GMAW), type of metal (mild steel, stainless steel, aluminum), type of shielding gas and size of electrode recommended for a particular mode.

The Weld Mode selection is enabled by toggling the SELECT switch until the LED next to Weld Mode is lit. A Weld Mode number will be displayed on the display meter. Toggling the SET switch up or down will increase or decrease the WELD MODE number displayed. The machine will change to the selected weld mode after two seconds of SET switch inactivity. If the SELECT switch is changed before two seconds of SET switch inactivity, the machine will not change modes. The last active Weld Mode will be saved at power down so that it will be selected with the next power up of the machine.

Preflow / Postflow

- The Preflow setting allows a time to be selected for shielding gas to flow after the trigger is pulled and prior to wire feeding and establishing an arc.
- The Postflow setting allows a time to be selected for shielding gas to continue to flow after the trigger is released and output current is turned off.
- The Preflow timer will be selected by toggling the SELECT switch until the LED next to PREFLOW /POSTFLOW is lit. The display meter will read Pre. The present Preflow time will be displayed and can be changed by positioning the SET switch up or down.
- The Postflow timer will be selected by pressing down the SELECT switch an additional time. The LED next to PREFLOW / POSTFLOW will remain lit; but the display meter will now read Pos. The present Postflow time will be displayed and can be changed by positioning the SET switch up or down.
- The default value for both Preflow and Postflow is "OFF" (0 seconds).
- Preflow can be adjusted from 0 to 2.5 seconds in 0.1 second increments.
- Postflow can be adjusted from 0 to 10.0 seconds in 0.1 second increments.

Run-In

- The Run-In function offers the ability to set a wire feed speed, from trigger until an arc is established, that is independent of the Welding or Start wire feed speed. Setting a Run-In WFS lower than the welding WFS avoids stubbing problems when starting the arc.
- Run-In is selected by toggling the SELECT switch until the LED next to RUN-IN is lit. A Run-In speed may be adjusted using the SET switch on the Multi-Process Panel. The Display meter on the Multi-Process Panel will indicate the run-in speed. **(Do not use the Output Control Knob on the upper case front to adjust the Run-In speed. This will change the welding WFS displayed in the meters on the upper case front.)**
- The default value for Run-In is "OFF."
- Run-In speed is adjustable from 50 ipm to 150 ipm (Inches per Minute).

Start Procedure

This machine provides the option of setting a Starting Procedure to start the weld, and from there, to ramp to the welding procedure over a specified amount of time. Typically starting on a higher starting procedure than the welding procedure is known as a "Hot Start". Setting a starting procedure lower than the welding procedure is known as a "Cold Start".

For **SMAW (Stick) welding** setting a "Hot Start" helps to minimize stubbing the electrode.

For **GTAW (TIG) welding** setting a "Cold Start" minimizes burn-through of thin materials when not using a manual amperage control.

For **Wire Feed welding** using a start procedure can help improve starting characteristics. A good example is when welding aluminum. Aluminum's high thermal conductivity results in heat spreading around the plate very fast. Therefore more energy is necessary at the very beginning to heat up the starting point of the weld. Once the welding begins, it is not necessary to give this extra heat anymore so a ramp down to the welding procedure is necessary.

To set a Start Procedure begin by using the SELECT switch to select the Start LED. Using the SET switch, enter the desired Start ramp time duration (its available values range from 0.01 seconds to 0.50 seconds in increments of 0.01 seconds or the default value of OFF). This value will be displayed on the digital meter of the multiprocess panel (See Figure B.2).

After setting the Start time also set the WFS, voltage/trim are adjustable using the control knobs on the upper case front. The way to know what information needs to be entered is to look for flashing LED's. If an LED is flashing that parameter value needs to be entered.

Arc Control (See Table B.2)

There are no specific unit values offered because the setting of this feature largely depends upon operator preference. Arc Control has a different effect on the character of the arc depending upon the welding process applied.

In **SMAW (STICK mode)**, arc control adjusts the arc force. It can be set to the lower range for a soft and less penetrating arc characteristic (negative numeric values) or to the higher range (positive numeric values) for a crisp and more penetrating arc. Normally, when welding with cellulosic types of electrodes (E6010, E7010, E6011), a higher energy arc is required to maintain arc stability. This is usually indicated when the electrode sticks to the work-piece or when the arc pops-out during manipulative technique. For low hydrogen types of electrodes (E7018, E8018, E9018, etc.) a softer arc is usually desirable and the lower end of the Arc Control suits these types of electrodes. In either case the arc control is available to increase or decrease the energy level delivered to the arc.

In **GMAW-S**, the short-circuiting mode of metal transfer, the Arc Control features the ability to increase or decrease the energy level at the arc. Setting the arc control from 1 to 10 decreases energy, and setting the Arc Control from 0 to -10 increases the energy delivered to the arc.

Solid carbon steel electrodes in a range from .025" - .045" (.6 mm – 1.1 mm) are nominally used, and the shielding gas blend for GMAW-S is usually 100% carbon dioxide or a blend of argon and carbon dioxide. The Arc Control in this scenario is set to control the droplet size and more pinch is added (increasing pinch reduces energy to the arc) to achieve the "bacon frying" sound associated with this mode of metal transfer.

Carbon steel electrodes employed in GMAW-S usually perform best when the droplet size is regulated by pinch to reduce the droplet size transferred with each short-circuit event.

When welding with solid stainless steel types of electrodes it is usually desirable to increase the energy delivered to the arc. High percentage argon blends with a 2 % addition of oxygen or a three part shielding gas blend comprised of 90% Helium + 7.5% Argon + 2.5 % carbon dioxide are usually employed. The added energy is associated, in this scenario, with increasing the inductance (negative numeric values). By adding to the energy level the weld bead appearance improves – spatter levels decrease and wetting action at the toes of a fillet weld increases. The arc is softer with the higher inductance setting and the arc lends itself to faster travel speed.

In **GMAW-P**, the pulsed spray mode of metal transfer, the Arc Control is, once again, used to increase and decrease the focus of the energy delivered to the arc. Increasing the setting in the range of +1 to +10 results in an increase in pulsed frequency, and the effect is to narrow the arc cone and concentrate the available energy to a smaller area. Decreasing the Arc Control setting from -1 to -10 results in a reduction of pulsed frequency – the result is a broader arc cone, which creates a wider weld bead.

Important to note here is that if a component of a pulsed waveform is increased, then another must be decreased. Adding pulsed frequency through an increase in the Arc Control setting, then also results in a proportional decrease in background current. If this were not the case, then the arc would become too long, with too much energy, and the arc would be unusable.

TABLE B.2-Arc control settings by process

PROCESS	ARC CONTROL SYNONYM	SETTING	APPLICATION AND RESULT
SMAW (STICK)	Arc Force	Lower (-1 to -10) for low hydrogen types of electrodes. Higher (+1 to +10) for cellulosic and other types.	Minus settings are soft and buttery for low hydrogen electrodes. Plus settings are harsh and digging for other types of electrodes.
GMAW – S (Short circuiting metal transfer)	Inductance or Pinch Control	Setting -1 to -10 for softer higher energy arc. Setting +1 to +10 for a crisper lower energy arc.	The minus settings result a more fluid puddle and larger droplet size. The positive settings reduce the droplet size and reduce energy to the arc.
GMAW – P (Pulsed spray metal transfer)	Pulsed frequency control	Minus settings reduces frequency. Plus settings increase frequency. weld	Wider arc cone and weld bead. Narrower arc cone and narrower bead.
Pulse – on –Pulse™ (Aluminum Only)	Pulsed frequency array control	Minus settings result in lower array frequency and the plus settings increase the array frequency.	Minus settings result in a wider bead with more distinct ripples. Plus settings narrow the resultant bead and the ripples are less distinct.

In the case of special waveforms designed for pulsed welding aluminum, Pulse on Pulse™, the effect is similar to what occurs with standard pulse. As the Arc Control is increased from +1 to +10 the frequency of the Pulse on Pulse array increases. As the frequency increases the weld bead ripples become less distinct and the arc cone narrows. When the Arc Control is set from -1 to -10 the Pulse on Pulse arrays decrease in frequency, the weld bead ripples become more distinct, and the bead width increases.

In **GMAW-PP mode**, arc control adjusts the modulation frequency, which means the speed at which the ripples are produced in the weld. (See Pulse-on-pulse description later in this section.) When faster travel speeds are desired, arc control needs to be set higher. When slower travel speeds are desired, arc control needs to be set lower.

- The Arc-control adjustment is selected by toggling the SELECT switch until the LED next to ARC CONTROL is lit. The Arc-control value will be displayed. Arc-control can be adjusted by toggling the SET switch up or down.
- The default value is "OFF."

Crater

The crater is the end of the weld, which normally solidifies creating a concave surface. This can result in stresses that can cause cracks in the center of the crater. The purpose of the Crater control is to fill up the crater, so that its surface becomes flat.

Crater control in this machine is more efficient than in other machines. Normally, in other machines, the crater filling procedure is a step down from the welding WFS to the crater filling WFS. In this machine instead of a step down, the transition is a ramp down, which results in a more controlled filling up of the crater and so, less stresses present in it.

The values to enter are first the desired time to stay at the Crater settings and the desired WFS and voltage/trim to fill the crater.

- The Crater timer is selected by toggling the SELECT switch until the LED next to CRATER is lit and flashing. A crater time may be set using the SET switch.
- The available values for crater control time go from "Off" to 0.1 seconds and from there to 10.0 seconds in increments of 0.1 seconds.
- The Crater function offers the ability to set an endpoint for WFS and Voltage that will be reached over a specified time period. At the end of the weld when the trigger is released, the crater timer will begin and the WFS and Volts settings will ramp down from the Weld Mode WFS and Voltage settings to the Crater WFS and Voltage settings over the time selected. This creates a ramp down of the WFS and Volts during the Crater time.

- In the GMAW, FCAW, and Power weld modes, crater WFS and voltage are adjustable using the control knobs on the upper case front. This is indicated by the flashing LED's next to "WFS" and "VOLTS."
- In the GMAW-P weld modes, Crater WFS and trim are adjustable. This is indicated by the flashing LEDs next to "WFS" and "TRIM."

Burnback

Setting the Burnback means setting the adjustable time delay between turning off the wire feeding and turning off the arc. Burnback helps to prevent wire sticking to the puddle.

- The Burnback feature will allow current to continue to flow for a specified time period at the end of a weld after wire feeding has stopped.
- The Burnback timer will be selected by toggling the SELECT switch until the LED next to BURNBACK is lit. A burnback time may be set using the SET switch.
- The default value is "OFF" (0 seconds).
- Burnback time is adjustable from 0 to 0.25 seconds in 0.01 second increments.

Spot

The Spot Timer adjusts arc on-time for spot or tack welds.

- With the Spot feature active (Spot time selected), when the trigger is pulled and the arc is established, the weld will continue until the expiration of the spot timer and the next active state will be enabled (crater or burnback). The trigger must be released and pulled again for another Spot cycle.
- The Spot timer is selected by toggling the SELECT switch until the LED next to SPOT is lit. The present SPOT time will be displayed and can be changed by toggling the SET switch up or down.
- The default value is "OFF" (0 seconds).
- Spot can be adjusted from 0 to 10.0 seconds in 0.1 second increments.

WIRE DRIVE ROLL

The drive rolls installed with the POWER MIG® 350MP have two grooves, one groove for .035" (0.9mm) solid steel electrode, and the other groove for the .045" (1.2mm) electrode. The actual drive roll size is stenciled on the side opposite of its groove. If feeding problems occur, a check may be required to make sure that the wire size and the drive roll size matches. See "Procedure for Changing Drive Rolls" in this section.

PROCEDURE FOR CHANGING DRIVE AND IDLE ROLL SETS

1. Turn off the power source.
2. Release the pressure on the idle roll by swinging the adjustable pressure arm down toward the back of the machine. Lift the cast idle roll assembly and allow it to sit in an upright position.
3. Remove the outside wire guide retaining plate by loosening the two large knurled screws.
4. Twist the drive roll retaining mechanism to the unlocked position as shown below and remove the drive roll. (See Figure B.3)

FIGURE B.3

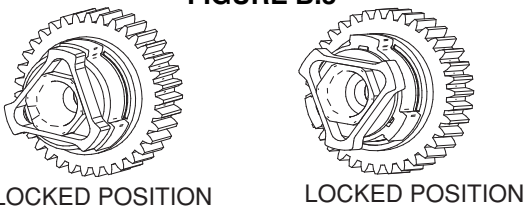

5. Remove the inside wire guide plate.
6. Replace the drive and idle rolls and inside wire guide with a set marked for the new wire size. **NOTE:** Be sure that the gun liner and contact tip are also sized to match the selected wire size.
7. Manually feed the wire from the wire reel, over the drive roll groove and through the wire guide and then into the brass bushing of the gun and cable assembly.
8. Replace the outside wire guide retaining plate by tightening the two large knurled screws. Reposition the adjustable pressure arm to its original position to apply pressure. Adjust pressure as necessary.

WIRE REEL LOADING - READI-REELS, SPOOLS OR COILS

To Mount a 30 Lb. (14 kg) Readi-Reel Package (Using the Molded Plastic K363-P Readi-Reel Adapter):

1. Open the Wire Drive Compartment Door
2. Depress the Release Bar on the Retaining Collar and remove it from the spindle.
3. Place the Optional Adapter on the spindle
4. Re-install the Retaining Collar. Make sure that the Release Bar "pops up" and that the collar retainers fully engage the retaining ring groove on the spindle.

5. Rotate the spindle and adapter so the retaining spring is at the 12 o'clock position.
6. Position the Readi-Reel so that it will rotate in a direction when feeding so as to be de-reeled from top the of the coil.
7. Set one of the Readi-Reel inside cage wires on the slot in the retaining spring tab.
8. Lower the Readi-Reel to depress the retaining spring and align the other inside cage wires with the grooves in the molded adapter.
9. Slide cage all the way onto the adapter until the retaining spring "pops up" fully.

⚠ CAUTION

Check to be sure the retaining ring has fully returned to the locking position and has securely locked the Readi-Reel cage in place. Retaining spring must rest on the cage, not the welding electrode.

10. To remove Readi-Reel from Adapter, depress retaining spring tab with thumb while pulling the Readi-Reel cage from the molded adapter with both hands. Do not remove adapter from spindle.

FIGURE B.4

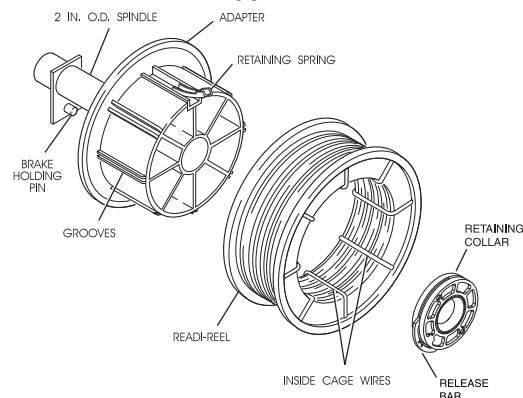

TO MOUNT 10 to 44 Lb. (4.5-20 kg) SPOOLS (12"/350MP mm Diameter) or 14Lb.(6 Kg) Innershield Coils:

(For 13-14 lb. (6 Kg) Innershield coils, a K435 Coil Adapter must be used).

1. Open the Wire Drive Compartment Door
2. Depress the Release Bar on the Retaining Collar and remove it from the spindle.
3. Place the spool on the spindle making certain the spindle brake pin enters one of the holes in the back side of the spool (Note: an arrow mark on the spindle lines up with the brake holding pin to assist in lining up a hole). Be certain the wire comes off the reel in a direction so as to de-reel from the top of the coil.

- Re-install the Retaining Collar. Make sure that the Release Bar “pops up” and that the collar retainers fully engage the retaining ring groove on the spindle.

FEEDING WIRE ELECTRODE

WARNING

When triggered, the electrode and drive mechanism are electrically “hot” relative to work and ground and remain “hot” several seconds after the gun trigger is released.

NOTE: Check that drive rolls, guide plates and gun parts are proper for the wire size and type being used. Refer to Table C.1 in ACCESSORIES section.

- Turn the Redi-Reel or spool until the free end of the electrode is accessible.
- While securely holding the electrode, cut off the bent end and straighten the first six inches. (If the electrode is not properly straightened, it may not feed properly through the wire drive system).
- Release the pressure on the idle roll by swinging the adjustable pressure arm down toward the back of the machine. Lift the cast idle roll assembly and allow it to sit in an upright position. Leave the outer wire guide plate installed. Manually feed the wire through the incoming guide bushing and through the guide plates (over the drive roll groove). Push a sufficient wire length to assure that the wire has fed into the gun and cable assembly without restriction. Reposition the adjustable pressure arm to its original position to apply pressure to the wire.
- Press gun trigger to feed the electrode wire through the gun.

IDLE ROLL PRESSURE SETTING

WARNING

ELECTRIC SHOCK can kill.



- Turn the input power OFF at the welding power source before installation or changing drive rolls and/or guides.
- Do not touch electrically live parts.
- When inching with the gun trigger, electrode and drive mechanism are “hot” to work and ground and could remain energized several seconds after the gun trigger is released.
- Only qualified personnel should perform maintenance work.

The pressure arm controls the amount of force the drive rolls exert on the wire. Proper adjustment of pressure arm gives the best welding performance.

Set the pressure arm as follows (See Figure B.2a):

Aluminum wires	between 1 and 3
Cored wires	between 3 and 4
Steel, Stainless wires	between 4 and 6

Figure B.2a

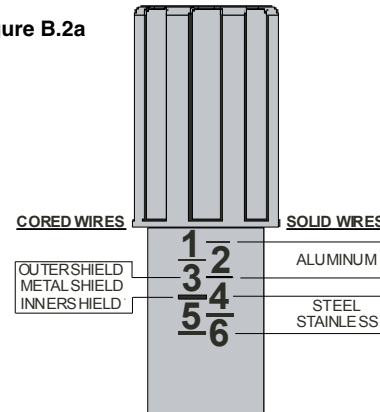

WIRE DRIVE CONFIGURATION

(See Figure B.2b)

Changing the Gun Receiver Bushing

WARNING

ELECTRIC SHOCK can kill.

- Turn the input power OFF at the welding power source before installation or changing drive rolls and/or guides.
- Do not touch electrically live parts.
- When inching with the gun trigger, electrode and drive mechanism are “hot” to work and ground and could remain energized several seconds after the gun trigger is released.
- Only qualified personnel should perform maintenance work.

Tools required:

- 1/4" hex key wrench.

Note: Some gun bushings do not require the use of the thumb screw.

- Turn power off at the welding power source.
- Remove the welding wire from the wire drive.
- Remove the thumb screw from the wire drive.
- Remove the welding gun from the wire drive.

5. Loosen the socket head cap screw that holds the connector bar against the gun bushing.
Important: Do not attempt to completely remove the socket head cap screw.
6. Remove the outer wire guide, and push the gun bushing out of the wire drive. Because of the precision fit, light tapping may be required to remove the gun bushing.
7. Disconnect the shielding gas hose from the gun bushing, if required.
8. Connect the shielding gas hose to the new gun bushing, if required.
9. Rotate the gun bushing until the thumb screw hole aligns with the thumb screw hole in the feed plate. Slide the gun receiver bushing into the wire drive and verify the thumb screw holes are aligned.
10. Tighten the socket head cap screw.
11. Insert the welding gun into the gun bushing and tighten the thumb screw.

AVOIDING WIRE FEEDING PROBLEMS

Wire feeding problems can be avoided by observing the following gun handling procedures:

1. Do not kink or pull cable around sharp corners.
2. Keep the gun cable as straight as possible when welding or loading electrode through cable.
3. Do not allow dolly wheels or trucks to run over cables.
4. Keep cable clean by following maintenance instructions.
5. Use only clean, rust-free electrode. Lincoln electrodes have proper surface lubrication.
6. Replace the contact tip when the arc starts to become unstable or the contact tip end is fused or deformed.
7. Keep wire reel spindle brake tension to the minimum required to prevent excess reel over-travel which may cause wire "loop-offs" from the coil.
8. Use proper drive rolls and wire drive/idle roll pressure for wire size and type being used.

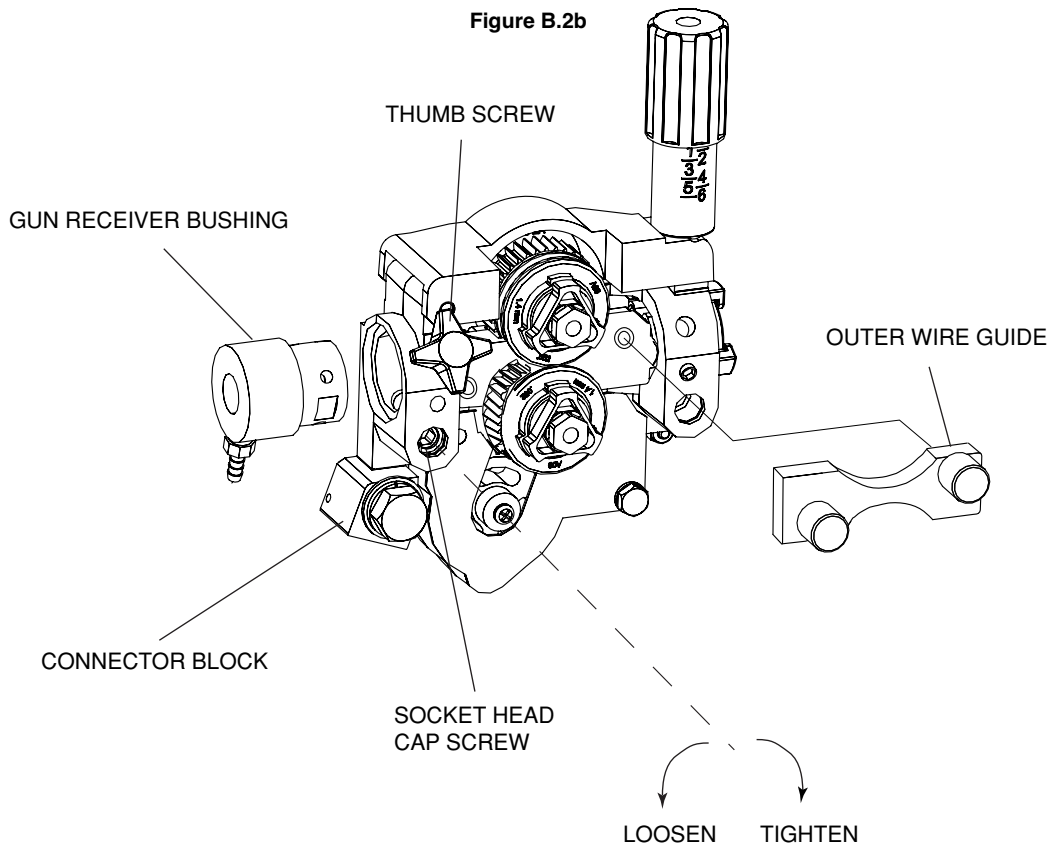

SPECIAL WELDING PROCESSES AVAILABLE ON THE POWER MIG® 350MP

PULSE WELDING (GMAW-P)

The pulsed-arc process is, by definition, a spray transfer process wherein spray transfer occurs in pulses at regularly spaced intervals. In the time between pulses, the welding current is reduced and no metal transfer occurs.

Pulsed-arc transfer is obtained by operating a power source between low and high current levels. The high current level or “pulse” forces an electrode drop to the workpiece. The low current level or “background” maintains the arc between pulses. (See Figure B.5).

Pulsed MIG is an advanced form of welding that takes the best of all the other forms of transfer while minimizing or eliminating their disadvantages. Unlike short circuit, pulsed MIG does not create spatter or run the risk of cold lapping. The welding positions in pulsed MIG are not limited as they are with globular or spray and its wire use is definitely more efficient. Unlike the spray arc process, pulsing offers controlled heat input that allows better welding on thin materials, lower wire feed speeds and leads to less distortion and improved overall quality and appearance. This is especially important with stainless, nickel and other alloys that are sensitive to heat input.

In **GMAW-P mode**, arc control adjusts the background current and frequency of the wave. When arc control goes up, the frequency increases thus increasing the droplet transfer rate.

FIGURE B.5

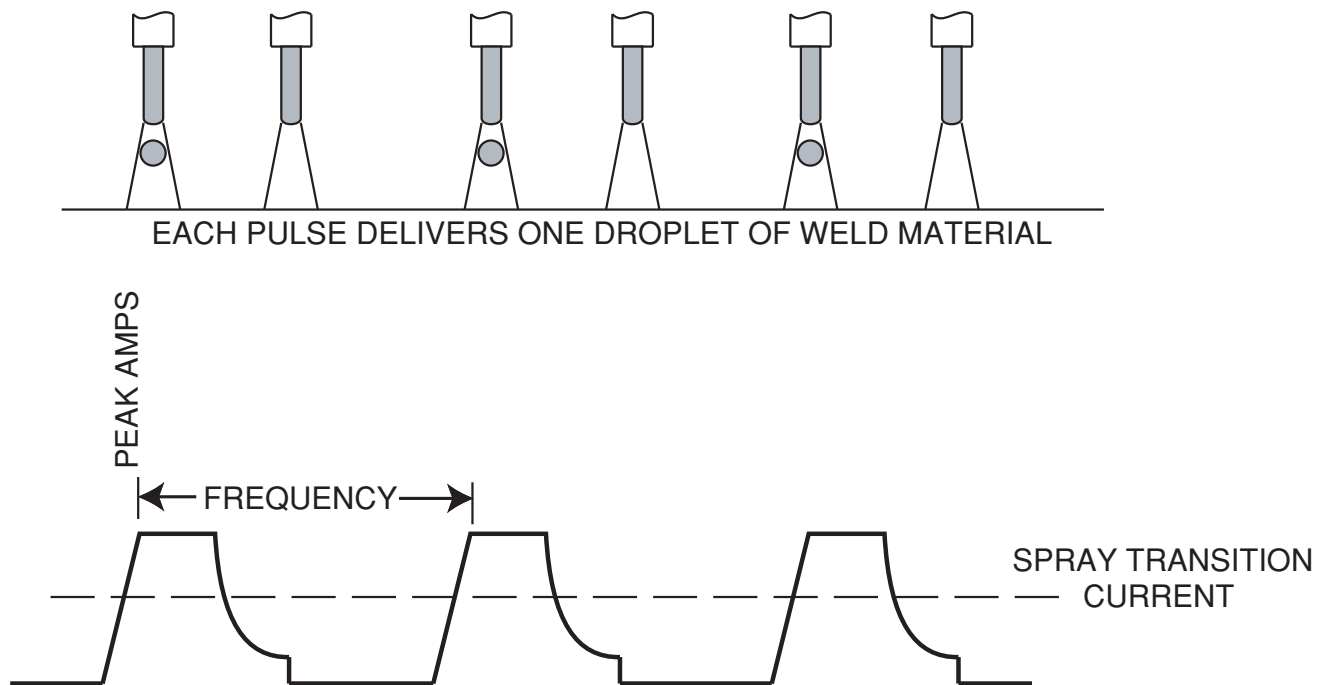

PULSE-ON-PULSE™ (GMAW-PP)

Pulse on Pulse™ is a Lincoln process specifically designed for use in welding relatively thin (less than 1/4" thick) aluminum (See Table B.3). It gives weld beads with very consistent uniform ripple.

In Pulse on Pulse modes, two distinct pulse types are used, instead of the single pulse type normally used in GMAW-P. A number of high energy pulses are used to obtain spray transfer and transfer metal across the arc. Such pulses are shown in Figure B.6. After a number "N" of such pulses, depending on the wire feed speed used, an identical number "N" of low energy pulses are performed. These low energy pulses, shown in Figure B.6, do not transfer any filler metal across the arc and help to cool the arc and keep the heat input low.

FIGURE B.6

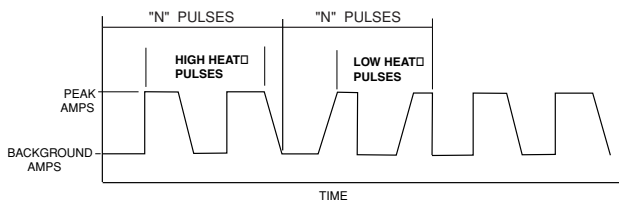

The Peak Current, Background Current, and Frequency are identical for the high energy and low energy pulses. In addition to cooling the weld down, the major effect of the low energy pulses is that they form a weld ripple. Since they occur at very regular time intervals, the weld bead obtained is very uniform with a very consistent ripple pattern. In fact, the bead has its best appearance if no oscillation of the welding gun ("whipping") is used. (See Figure B.7)

FIGURE B.7

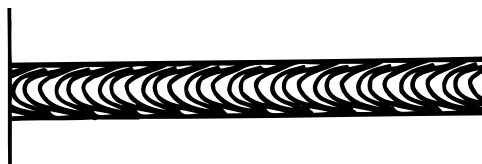

When Arc Control is used in the Pulse on Pulse modes, it does the same things it does in the other pulsed modes: decreasing the Arc Control decreases the droplet transfer and weld deposition rate. Increasing the Arc Control increases the droplet transfer and weld deposition rate. Since Arc Control varies weld droplet transfer rate, the Arc Control can be used to vary the ripple spacing in the weld bead.

BENEFITS OF PULSE ON PULSE FROM LINCOLN ELECTRIC

- Excellent appearance of the weld bead
- Improved cleaning action
- Reduced porosity

Table B.3 shows WFS and Trim settings for common aluminum types and wire sizes when welding with Pulse-on-Pulse. The welds made to obtain the values in the table were fillet welds in the flat position. The values in the table can be helpful as a starting point to establish a welding procedure. From there, adjustments need to be made to set the proper procedure for each specific application (out-of-position, other types of joints, etc.).

The comments on Table B.3 show values of WFS below which it is not recommended to weld. The reason is, that below these values the weld transfer will change from a spray arc to a short-arc, which is not advisable when welding aluminum.

WELDING PROCEDURES FOR PULSE-ON-PULSE (TABLE B.3)

MATERIAL	Aluminum 4043	Aluminum 4043	Aluminum 5356	Aluminum 5356
GAS	100% Ar.	100% Ar.	100% Ar.	100% Ar.
WIRE	E4043	E4043	E5356	E5356
WIRE SIZE	0.035	3/64	0.035	3/64
WELD MODE	98	99	101	102
MATERIAL THICKNESS WFS / TRIM	14 ga.	250 / 1.0	200 / 1.0	230 / 1.0
	10 ga.	400 / 1.0	280 / 1.0	425 / 1.0
	3/16	550 / 1.0	340 / 1.0	670 / 1.0
	1/4	600 / 1.0	400 / 1.0	700 / 1.0
COMMENTS	Not Recommended below 200 WFS	Not Recommended below 100 WFS	Not Recommended below 200 WFS	Not Recommended below 200 WFS

POWER MODE™

The Power Mode™ process was developed by Lincoln to maintain a stable and smooth arc at low procedure settings which are needed to weld thin metal without pop-outs or burning-through. For Aluminum welding, it provides excellent control and the ability to maintain constant arc length. This results in improved welding performance in two primary types of applications.

- Short Arc MIG at low procedure settings.
- Aluminum MIG welding.

Power Mode™ is a method of high speed regulation of the output power whenever an arc is established. It provides a fast response to changes in the arc. The higher the Power Mode Setting, the longer the arc. If a welding procedure is not established, the best way to determine the Power Mode Setting is by experimentation until the desired output result is established.

In the Power Mode two variables need to be set:

- Wire Feed Speed
- Power Mode Trim

Setting up a Power Mode procedure is similar to setting a CV MIG procedure. Select a shielding gas appropriate for a short arc process.

- For steel, use 75/25 Ar/CO₂ shield gas.
- For Stainless, select a Helium blend Tri-Mix.
- For Aluminum, use 100% Ar.

Start by setting the wire feed speed based upon mate-

rial thickness and appropriate travel speed. Then adjust the Volts/Trim knob as follows:

- For steel, listen for the traditional “frying egg” sound of a good short-arc MIG procedure to know you have the process set correctly.
- For aluminum, simply adjust the Volts/Trim knob until the desired arc length is obtained.

Note the Volts/Trim display is simply a relative number and DOES NOT correspond to voltage.

TIG WELDING:

The basic sequence of operation.

1. Use SET toggle to select GTAW (Mode 03)
2. Adjust desired amperage using WFS/AMPS CONTROL. If using an optional foot or hand Amptrol to control current this setting will be maximum when the Amptrol is fully depressed or extended.
3. Energize output with either a remote trigger device plugged into the remote connector, or rotate VOLTS/TRIM CONTROL clockwise.
4. Touch tungsten to work piece and lift off to establish the arc.
5. START can be set by using the SELECT toggle. Use the WFS/AMPS Control to set the respective start current.

DRIVE ROLL KITS

Refer to Table C.1 for various drive roll kits that are available for the POWER MIG® 350MP. All items in **Bold** are supplied standard with the POWER MIG® 350MP.

TABLE C.1

Wire	Size	Drive Roll Kit
Solid Steel	.023"-.030" (0.6-0.8 mm)	KP1696-030S
	.035" (0.9 mm)	KP1696-035S
	.045" (1.2 mm)	KP1696-045S
	.035-.045" (0.9-0.2mm)	KP-1696-1
	.040" (1.0mm)	KP-1696-2
Cored	.035" (0.9 mm)	KP1697-035C
	.045" (1.2 mm)	KP1697-045C
Aluminum	3/64" (1.2 mm)	KP1695-3/64A

*.035 Aluminum recommended for Push-Pull systems only.

K363P READI-REEL ADAPTER

The K363P Readi-Reel Adapter mounts to the 2" spindle. It is needed to mount the 22-30 lb. Readi-Reels.

DUAL CYLINDER MOUNTING KIT (K1702-1)

Permits stable side-by-side mounting of two full size (9" dia. x 5' high) gas cylinders with "no lift" loading. Simple installation and easy instructions provided. Includes upper and lower cylinder supports, wheel axles and mounting hardware.

MAGNUM GMAW GUN AND CABLE ASSEMBLIES

The following Magnum 350MP gun and cable assemblies are separately available for use with the POWER MIG® 350MP. Each is rated 350 amps 60% duty cycle (or 350 amps 40% duty) and is equipped with the integrated connector, twist-lock trigger connector, fixed nozzle and insulator, and includes a liner, diffuser, and contact tips for the wire sizes specified:

Part No.	Length	Wire Size	Metric Wire Size
K470-1	10' (3.0 m)	.035 – .045"	0.9 – 1.2 mm
K470-2 [†]	15' (4.6 m)	.035 – .045"	0.9 – 1.2 mm
K470-4	15' (4.6 m)	.052 – 1/16"	1.3 – 1.6 mm
K470-6	15' (4.6 m)	1/16 – 5/64"	1.6 – 2.0 mm

[†]This Part Number is the standard Gun and Cable Assembly sent with the POWER MIG® 350MP from the factory.

MAGNUM GUN CONNECTION KIT (Optional K466-6)

Using the optional K466-6 Magnum Connection kit for the POWER MIG® 350MP permits use of standard Magnum 200, 350 or 400 gun and cable assemblies.

CAUTION

Closing either gun trigger will cause the electrode of both guns to be electrically "HOT". Be sure unused gun is positioned so electrode or tip will not contact metal case or other metal common to work.

Because the control circuitry senses each gun through its trigger leads, weld parameters are displayed and adjustable for the last gun that was triggered.

- Pulling the trigger for the built-in feeder gun (Magnum 350):**
 - Disables spool gun operation.
 - Changes the displays of the POWER MIG® 350MP to correspond to feeder gun operation.
 - Closing feeder gun trigger starts feeder gun welding and makes both electrodes electrically "HOT".
- Pulling SPOOL GUN Trigger:**
 - Disables built-in feeder gun operation.
 - Changes the displays of the POWER MIG® 350MP to correspond to Spool Gun operation.
 - Closing spool gun trigger starts spool gun welding and makes both electrodes electrically "HOT".
- Operation with POWER MIG® 350MP:**
 - Install the spool gun per the installation instructions
 - Turn the POWER MIG® 350MP input power ON.
 - Make sure that the Gun Selector Switch is in the "Standard / Spool Gun" position.
 - Pull and release the trigger of the Spool Gun. The POWER MIG® recognizes the spool gun as active and weld parameters are adjustable for welding with the Spool Gun

Non-Synergic Weld Modes (Mode 5)

- Voltage is adjustable at the power source. The right control knob on the power source will adjust the voltage that is displayed in the meter directly above it.
- The left Display (WFS / AMPS) on the POWER MIG® 350MP will have 4 dashes (----) to indicate that the left control knob on the power source is inactive. Wire Feed Speed is set at the Spool Gun.
- The following procedure settings for Aluminum 4043 can be used as initial settings for making test welds to determine final settings:

Wire Dia. In. (mm)	WFS Setting Spool Gun	Arc Voltage Setting
.030" (.8 mm)	270	15V
.035" (.9 mm)	250	16V
3/64" (1.2 mm)	240	20V

4. Synergic Weld Modes

The POWER MIG® 350MP is designed to enable synergic weld modes and synergic pulse processes with the spool gun. The actual wire feed speed (WFS) of the spool gun must be measured and manually set on the POWER MIG® 350MP as a work point for the POWER MIG® 350MP (SPD).

- In synergic modes when the spool gun trigger is pulled, an adjustable value for the SPD work point is displayed in the left meter. The letters SPD are displayed in the right meter.
- The left control knob adjusts the SPD value. The right control knob is inactive.
- Measure the actual WFS, in inches per minute, at the spool gun and set the SPD at the POWER MIG® 350MP to match this value. WFS can be measured by pulling the trigger of the spool gun and feeding wire for 6 seconds. Measure the length of wire (in inches) that was fed and multiply by 10.
- The POWER MIG® 350MP is now configured and ready to weld in the synergic mode.
- Adjustment of the SPD value from the set value has the affect of adjusting trim or arc length.
- To increase the arc length; increase the SPD value at the POWER MIG® 350MP to a value higher than the actual WFS.

Remember; do not change the WFS at the spool gun.

- To decrease the arc length; decrease the SPD value at the POWER MIG® 350MP to a value lower than the actual WFS.

Remember: The dialed in SPD value at the POWER MIG® 350MP does not control the WFS at the spool gun. Rather, it is adjusting the POWER MIG® 350MP synergic work point. Therefore, adjusting the SPD value will not change your actual WFS at the spool gun. WFS can only be changed at the spool gun.

PUSH-PULL TORCHES

Torch	Part No.	Adapter Kit
Magnum PRO Push-Pull Gun, 15' 7Pin	K3356-1	not required
Magnum PRO Push-Pull Gun, 25' 7Pin	K3356-2	
Magnum PRO Push-Pull Gun, 35' 7Pin	K3356-3	
Magnum PRO Push-Pull Gun, 50' 7Pin	K3356-4	

⚠ CAUTION

Remove all input power to the POWER MIG® 350MP before installing the Connection Adapter Kit.

⚠ WARNING

Refer to the Owner's Manual of the Torch for Amperage and Duty Cycle rating information. The torch rating may not match the rating of the power source.

MAKING A WELD WITH THE PUSH PULL TORCH INSTALLED

- Set the idle roll pressure on the wire drive between an indicator reading of 0-2. A recommended start point is 1.5.
- Set the Gun Selection toggle switch located inside the wire drive compartment directly above the push-pull control cable connector to "PUSH-PULL GUN."
- Depending on the weld mode, set the Voltage or Trim at the POWER MIG® 350MP using the right control knob located on the upper case front panel.
- The Wire Feed Speed (WFS) is set using the control knob on the Torch. The left control knob on the POWER MIG® 350MP is inactive. The actual WFS being set at the torch is displayed on the POWER MIG® 350MP.
- All weld parameters normally available for the active weld mode are available during push-pull operation. Refer to the Operation Section of this manual.

DUAL PROCEDURE KIT (K2449-1)

- Allows to switch between two procedure settings.

SAFETY PRECAUTIONS

WARNING



ELECTRIC SHOCK can kill.

- Have an electrician install and service this equipment.
- Turn the input power off at the fuse box before working on equipment
- Do not touch electrically hot parts.

GENERAL MAINTENANCE

In extremely dusty locations, dirt may clog the air passages causing the welder to run hot. Blow dirt out of the welder with low-pressure air at regular intervals to eliminate excessive dirt and dust build-up on internal parts.

The fan motors have sealed ball bearings which require no service.

DRIVE ROLLS AND GUIDE PLATES

After every coil of wire, inspect the wire drive mechanism. Clean it as necessary by blowing with low pressure compressed air. Do not use solvents for cleaning the idle roll because it may wash the lubricant out of the bearing. All drive rolls are stamped with the wire sizes they will feed. If a wire size other than that stamped on the roll is used, the drive roll must be changed.

For instructions on replacing or changing drive roll, see “Wire Drive Rolls” in Operation section.

CONTACT TIP AND GAS NOZZLE INSTALLATION

- a. Choose the correct size contact tip for the electrode being used (wire size is stenciled on the side of the contact tip) and screw it snugly into the gas diffuser.
- b. Be sure the nozzle insulator is fully screwed onto the gun tube and does not block the gas holes in the diffuser. (**NOTE:** Insulator is not required when using the optional fixed gas nozzles.)
- c. Slip the appropriate gas nozzle onto the nozzle insulator. Adjustable gas nozzles are available with a .62” (15.9 mm) or .50” (12.7 mm) I.D., and in both standard (flush) and recessed design. The proper nozzle should be selected based on the welding application. Different length fixed nozzles are also available to fit 350MP and 400 amp gun tubes to allow either spray or short-circuiting transfer welding.

Choose the gas nozzle as appropriate for the GMAW process to be used. Typically, the contact tip end should be flush to .12” (3.1 mm) extended for the short-circuiting transfer process and .12” (3.1 mm) recessed for spray transfer. For the Outershield (FCAW) process, 1/8” (3 mm) recess is recommended.

GUN TUBES AND NOZZLES

- a. Replace worn contact tips as required.
- b. Remove spatter from inside of gas nozzle and from tip after each 10 minutes of arc time or as required.

GUN CABLE CLEANING

To help prevent feeding problems, clean cable liner after using approximately 350MP pounds (136 kg) of electrode. Remove the cable from the wire feeder and lay it out straight on the floor. Remove the contact tip from the gun. Using an air hose and only partial pressure, gently blow out the cable liner from the gas diffuser end.

⚠ CAUTION

Excessive pressure at the start may cause the dirt to form a plug.

Flex the cable over its entire length and again blow out the cable. Repeat this procedure until no further dirt comes out. If this has been done and feed problems are experienced, try liner replacement, and refer to trouble shooting section on rough wire feeding.

LINER REMOVAL AND REPLACEMENT (SEE FIGURE D.1)

LINER REMOVAL, INSTALLATION AND TRIMMING INSTRUCTIONS FOR MAGNUM 350MP

NOTE: The variation in cable lengths prevents the interchangeability of liners between guns. Once a liner has been cut for a particular gun, it should not be installed in another gun unless it can meet the liner cutoff length requirement. Liners are shipped with the jacket of the liner extended the proper amount.

1. Remove the gas nozzle.
2. Remove the gas diffuser from the gun tube.
3. Lay gun and cable out straight on a flat surface.
Loosen set screw of the connector on the back end of the gun.

4. Insert the untrimmed Liner into the back end of the gun.
5. Seat Liner bushing into back of gun. Secure Liner by tightening set screw. Do not install the gas diffuser at this time.
6. Lay the cable straight and trim Liner to 9/16". Remove burrs.
7. Install insulator and secure the gas diffuser into the tube.

FIGURE D.1

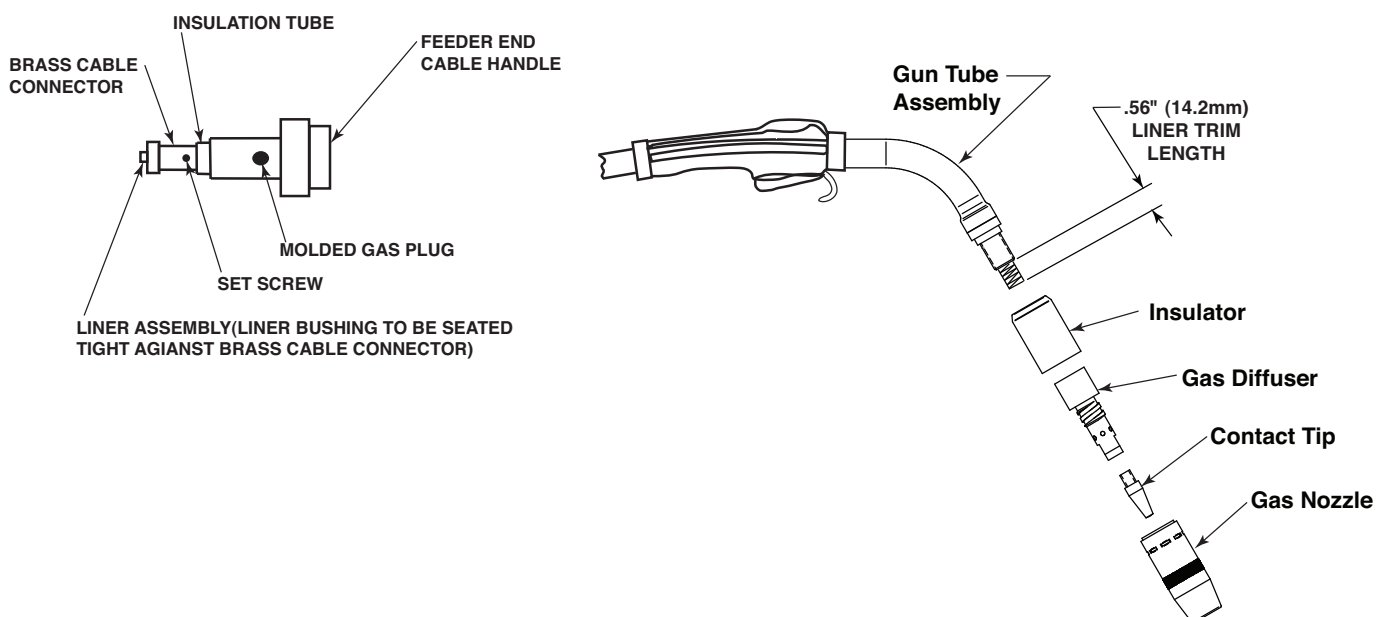

Push-Pull Gun Calibration

an adjustment on the POWER MIG® 350MP that allows the welder to adjust the speed of the pull motor. The purpose is to synchronize the speeds of the rear push motor and front pull motor.

Checking Gun Calibration

1. Turn off all settings in the weld mode (pre/post flow, run-in, start/spot/crater time, and burn back)
2. Adjust wire feed speed to 360 (360 inches per minute = 60 inches in 10 sec)
3. Disengage the rear drive motor (By opening the tension lever - See figure D.1)

FIGURE D.1

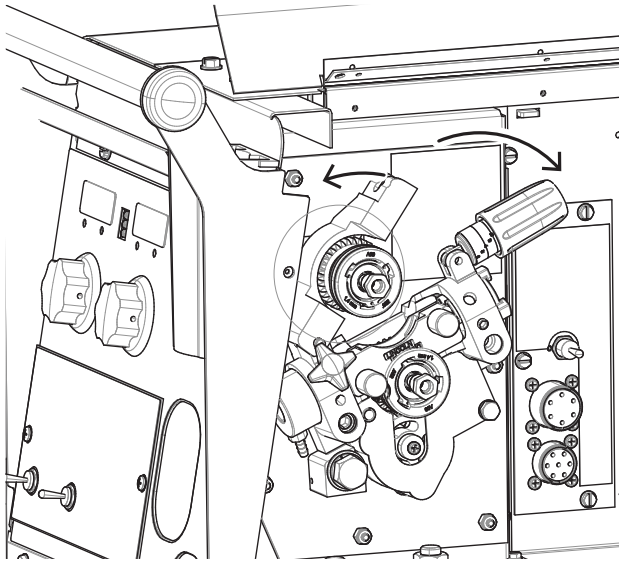

4. Disconnect the gun from the gun receiver bushing and cut the wire at the front of the machine (Wire should run through the conduit only)
5. Make sure the gun and cable assembly are straight
6. Using a stop watch, pull the trigger for 10 seconds
7. Measure the wire from the tip of the torch to the end of the wire
8. The wire should measure just under 60 inches
9. Perform the gun calibration if the measurement is less than 57 or greater than 63

Gun Calibration Procedure

1. Turn the POWER MIG® 350MP off.
2. Hold “select” switch up while powering up machine.
3. Release “select” switch when displays show “Pres sPin”
4. Turn the volts / trim knob until displays show “9un CAL”.
5. Toggle the “select” switch up and release.
6. Right display should display a number
7. Use the volts / trim knob to adjust the calibration value (The higher the number the faster the motor, the lower the number the slower the motor.)
8. Toggle the “select” switch up and release to save.
9. The right display should scroll the word “SAVED”
10. Toggle the “select” switch up and release
11. Displays show “Pres sPin”
12. Toggle the “select” switch up and release to exit menu
13. Check calibration and repeat if necessary

⚠ WARNING

Service and Repair should only be performed by Lincoln Electric Factory Trained Personnel. Unauthorized repairs performed on this equipment may result in danger to the technician and machine operator and will invalidate your factory warranty. For your safety and to avoid Electrical Shock, please observe all safety notes and precautions detailed throughout this manual.

This Troubleshooting Guide is provided to help you locate and repair possible machine malfunctions. Simply follow the three-step procedure listed below.

Step 1. LOCATE PROBLEM (SYMPTOM).

Look under the column labeled “PROBLEM (SYMPTOMS)”. This column describes possible symptoms that the machine may exhibit. Find the listing that best describes the symptom that the machine is exhibiting.

Step 2. POSSIBLE CAUSE.

The second column labeled “POSSIBLE CAUSE” lists the obvious external possibilities that may contribute to the machine symptom.

Step 3. RECOMMENDED COURSE OF ACTION

This column provides a course of action for the Possible Cause, generally it states to contact your local Lincoln Authorized Field Service Facility.

If you do not understand or are unable to perform the Recommended Course of Action safely, contact your local Lincoln Authorized Field Service Facility.

⚠ CAUTION

If for any reason you do not understand the test procedures or are unable to perform the tests/repairs safely, contact your **Local Lincoln Authorized Field Service Facility** for technical troubleshooting assistance before you proceed.

Observe all Safety Guidelines detailed throughout this manual

PROBLEMS (SYMPTOMS)	POSSIBLE CAUSE	RECOMMENDED COURSE OF ACTION
Major physical or electrical damage is evident when the sheet metal covers are removed.	1. Contact your local authorized Lincoln Electric Field Service facility for technical assistance.	If all recommended possible areas of misadjustment have been checked and the problem persists, Contact your local Lincoln Authorized Field Service Facility.
Input fuses keep blowing, or input breaker keeps tripping	1. Make certain that the fuses or breakers are properly sized. See installation section of the manual for recommended fuse and breaker sizes. 2. Welding procedure is drawing too much output current, or duty cycle is too high. Reduce output current, duty cycle or both. 3. There is internal damage to the power source. Contact an authorized Lincoln Electric Service facility.	
Machine will not power up (No lights)	1. Make certain that the power switch is in the "ON" position. 2. Input voltage selection made improperly. Power down, check input voltage reconnect according to diagram on reconnect cover.	
Machine won't weld, can't get any output.	1. If the displays show an Err ### see the fault section for corrective action. 2. If the displays are not lit refer to machine will not power up section. 3. If the thermal symbol is lit refer to the thermal section.	
Thermal symbol is lit	1. Check for proper fan operation 2. Check for material blocking intake or exhaust louvers.	

⚠ CAUTION

If for any reason you do not understand the test procedures or are unable to perform the tests/repairs safely, contact your **Local Lincoln Authorized Field Service Facility** for technical troubleshooting assistance before you proceed.

Observe Safety Guideline detailed in the beginning of this manual.

PROBLEMS (SYMPTOMS)	POSSIBLE CAUSE	RECOMMENDED COURSE OF ACTION
OUTPUT PROBLEMS		
Output voltage and wire feed is present when gun trigger is not pulled (not activated).	<ol style="list-style-type: none"> 1. Check Weld Mode to make sure the unit is in a CV Mode And not a CC Mode. 2. Remove gun assembly from machine. If problem is solved gun assembly is faulty. Repair or replace. 3. If problem persists when gun assembly is removed from machine then the problem is within the POWER MIG® 350MP. 	<p>If all recommended possible areas of misadjustment have been checked and the problem persists, Contact your local Lincoln Authorized Field Service Facility.</p>
Machine output is low. Welds are “cold”, weld bead is rounded or bumped up demonstrating poor wetting into plate.	<ol style="list-style-type: none"> 1. Check input voltage. Make sure input voltage matches name-plate rating and reconnect panel configuration. 2. Make sure settings for wire feed speed and voltage are correct for process being used. 3. Make sure output polarity is correct for process being used. 4. Check welding cables and gun assembly for loose or faulty connections. 	
Poor arc striking with electrode sticking or blasting off.	<ol style="list-style-type: none"> 1. Make sure settings for wire feed speed and voltage are correct for process being used. 2. The Run-In (Fast or Slow) speed may be wrong for process and technique being used. See Operation Section. 3. The gas shielding may be improper for process being used. 	

⚠ CAUTION

If for any reason you do not understand the test procedures or are unable to perform the tests/repairs safely, contact your **LOCAL AUTHORIZED LINCOLN ELECTRIC FIELD SERVICE FACILITY** for assistance before you proceed.

Observe Safety Guidelines detailed in the beginning of this manual.

PROBLEMS (SYMPTOMS)	POSSIBLE CAUSE	RECOMMENDED COURSE OF ACTION
FEEDING PROBLEMS		
Rough wire feeding or wire will not feed but drive rolls are turning.	<ol style="list-style-type: none"> 1. The gun cable may be kinked or twisted. 2. The wire may be jammed in the gun cable, or gun cable may be dirty. 3. Check drive roll tension and position of grooves. 4. Check for worn or loose drive rolls. 5. The electrode may be rusty or dirty. 6. Check for damaged or incorrect contact tip. 7. Check wire spindle for ease of rotation and adjust break tension knob if necessary. 	<p>If all recommended possible areas of misadjustment have been checked and the problem persists, Contact your local Lincoln Authorized Field Service Facility.</p>
The wire feed stops while welding. When trigger is released and pulled again the wire feed starts.	<ol style="list-style-type: none"> 1. Check the wire feed drive rolls and motor for smooth operation. 2. Check for restrictions in the wire feed path. Check the gun and cable for restrictions. 3. Make sure gun liner and tip are correct for wire size being used. 4. Make sure drive rolls and guide plates are clean and are the correct size. 5. Check spindle for ease of rotation. 	

⚠ CAUTION

If for any reason you do not understand the test procedures or are unable to perform the tests/repairs safely, contact your **LOCAL AUTHORIZED LINCOLN ELECTRIC FIELD SERVICE FACILITY** for assistance before you proceed.

Observe Safety Guidelines detailed in the beginning of this manual.

PROBLEMS (SYMPTOMS)	POSSIBLE CAUSEF	RECOMMENDED COURSE OF ACTION
GAS FLOW PROBLEMS		
<p>Gas does not flow when gun trigger is pulled.</p>	<ol style="list-style-type: none"> 1. Make sure gas supply is connected properly and turned "on". 2. If the gas solenoid does actuate (click) when the gun trigger is pulled there may be a restriction in the gas supply line. 3. The gun cable assembly may be faulty. Check or replace. 4. If gas solenoid does not operate when gun trigger is pulled the problem is within the POWER MIG® 350MP. 5. Make sure the gun is pushed all the way into gun mount and is properly seated. 	<p>If all recommended possible areas of misadjustment have been checked and the problem persists, Contact your local Lincoln Authorized Field Service Facility.</p>

⚠ CAUTION

If for any reason you do not understand the test procedures or are unable to perform the tests/repairs safely, contact your **LOCAL AUTHORIZED LINCOLN ELECTRIC FIELD SERVICE FACILITY** for assistance before you proceed.

Observe all Safety Guidelines detailed throughout this manual

Fault Codes			
Code	Description	Possible Cause	Corrective Action
39	Glitch on the primary over current fault interrupt; possibly caused by noise or a signal level (misc. hardware fault #1)	Check the machine ground. If problem persists contact an authorized Lincoln Field Service Shop.	Self-clearing as condition ceases.
44	Main CPU problem. The DSP has detected a problem with the CPU.	Check the machine ground.	
47	Glitch on the CAP/heart beat interrupt; possibly caused by noise or a signal level right at the trip threshold. (misc. hardware fault #2)	If problem persists contact an authorized Shop.	
81	Motor overload-average motor current exceeded 8.00 amps for more than 0.50 seconds	Verify motor armature is not binding. Verify Wire Spool is not binding.	
82	Motor overcurrent-average motor current exceeded 3.50 amps for more than 10.0 seconds	Verify wire can move freely in cable. Verify Spool Brake is not set to tight.	

Displays	Description
Scrolling dash	Appears at power up while the machine is going through its self configuration. (If continuous, perform "Clear All" procedure)
"Err" "####"	Fault code display. The first fault to occur will be displayed for three seconds. The display will cycle through fault codes for all faults that persist after the initial three-second period are displayed for 1 second each.
"----" "----"	Weld mode is changing
"####" "####"(on steady)	Machine output is on. Left display is current, right display is voltage. If actively welding, the displays are arc current and arc voltage. If not actively welding, the display will show work point.
"####" "####" (blinking)	Weld just finished – the average arc voltage and current will be blinked for 5 seconds following a weld. If the work point changes during this 5 second period, the display will revert to the above mode.

CAUTION

If for any reason you do not understand the test procedures or are unable to perform the tests/repairs safely, contact your **Local Lincoln Authorized Field Service Facility** for technical troubleshooting assistance before you proceed.

Observe all Safety Guidelines detailed throughout this manual

PROBLEMS (SYMPTOMS)	POSSIBLE CAUSE	RECOMMENDED COURSE OF ACTION
PUSH PULL WIRE FEEDING PROBLEMS		
<p>While loading wire, the rear drive rolls stop while pushing wire through the torch.</p>	<ol style="list-style-type: none"> 1. Check torch cable for kinks. Torch cable should be laid out relatively straight. 2. Check to see that the spindle brake is not set too tight. There should be an aluminum spacer behind the spindle brake. Refer to the push-pull connection kit for this spacer. 3. Check the wire at the spool. Make sure wire is not crossed and is de-reeling properly. 4. Increase wire feed speed to 350-400 ipm. 5. If problem continues after 1 thru 4 are checked then the Stall Factor Number needs to be increased. (See: Stall Factor Number Adjustment) 	<p>If all recommended possible areas of misadjustment have been checked and the problem persists, Contact your local Lincoln Authorized Field Service Facility.</p>
<p>While loading wire, the wire bird nests before the wire gets all the way through the torch.</p>	<ol style="list-style-type: none"> 1. Check torch cable for kinks. Torch cable should be laid out relatively straight. 2. Make sure liner conduit is inserted all the way into the rear wire drive so that it is up against the inner black plastic wire guide. 3. Inner black plastic wire guide is worn out. Replace guide. 4. Slow down wire feed speed while pushing wire up through the liner. Recommended setting = 350MP ipm. 5. Clean or replace contact tip. 	

⚠ CAUTION

If for any reason you do not understand the test procedures or are unable to perform the tests/repairs safely, contact your **Local Lincoln Authorized Field Service Facility** for technical troubleshooting assistance before you proceed.

Observe all Safety Guidelines detailed throughout this manual

PROBLEMS (SYMPTOMS)	POSSIBLE CAUSE	RECOMMENDED COURSE OF ACTION
PUSH PULL WIRE FEEDING PROBLEMS		
<p>While loading wire the wire bird nests if the wire misses the outlet guide while shooting the gap in the torch.</p>	<ol style="list-style-type: none"> 1. Straighten the first six inches of the wire before feeding it into the rear wire drive. 2. Make sure the torch drive rolls are tightened slightly to help the wire jump the gap. 3. Slow down wire feed speed while pushing wire through torch liner. Recommend setting = 350 ipm. 4. If problem continues after 1 thru 3 are checked then the Stall Factor Number needs to be decreased. (See: Stall Factor Number Adjustment) 	<p>If all recommended possible areas of misadjustment have been checked and the problem persists, Contact your local Lincoln Authorized Field Service Facility.</p>
<p>Arc length varies while welding (arc length is not constant).</p>	<ol style="list-style-type: none"> 1. POWER MIG® 350MP drive rolls set too tight. The tension arm should be set at 1 to 1-1/2. 2. Check to see that the spindle brake is not set too tight. There should be an aluminum spacer behind the spindle brake. Refer to the push-pull connection kit for this spacer. 3. Clean or replace contact tip. 4. If problem continues after 1 and 3 are checked then the Stall Factor Number needs to be increased. (See Stall Factor Number Adjustment) 	

⚠ CAUTION

If for any reason you do not understand the test procedures or are unable to perform the tests/repairs safely, contact your **Local Lincoln Authorized Field Service Facility** for technical troubleshooting assistance before you proceed.

Observe all Safety Guidelines detailed throughout this manual

PROBLEMS (SYMPTOMS)	POSSIBLE CAUSE	RECOMMENDED COURSE OF ACTION
PUSH PULL WIRE FEEDING PROBLEMS		
<p>During Welding the wire continues to burn back to the tip.</p>	<ol style="list-style-type: none"> 1. Check to see that the spindle brake is not set too tight. There should be an aluminum spacer behind the spindle brake. Refer to the push-pull connection kit for this spacer. 2. POWER MIG® 350MP drive rolls set too tight. The tension arm should be set at 1 to 1-1/2. 3. Push-Pull torch drive rolls set too tight. Refer to owners manual for proper setting. 4. If pulse welding the trim value may be set too high. 5. Clean or replace contact tip. 6. If problem continues after 1 thru 5 are checked then the Stall Factor Number needs to be increased. (See Stall Factor Number Adjustment) 	<p>If all recommended possible areas of misadjustment have been checked and the problem persists, Contact your local Lincoln Authorized Field Service Facility.</p>
<p>Wire bird nests while welding.</p>	<ol style="list-style-type: none"> 1. Torch liner conduit not inserted all the way so that it is touching the inner black plastic wire guide. 2. Inner black plastic wire guide is worn out. Replace guide. 3. Push-Pull torch drive rolls set too tight. Refer to owners manual for proper setting. 4. If problem continues after 1 thru 3 are checked then lower your Stall Factor Number. (See: Stall Factor Number Adjustment) 	

⚠ CAUTION

If for any reason you do not understand the test procedures or are unable to perform the tests/repairs safely, contact your **Local Lincoln Authorized Field Service Facility** for technical troubleshooting assistance before you proceed.

Observe all Safety Guidelines detailed throughout this manual

PUSH PULL WIRE FEEDING PROBLEMS

STALL FACTOR - an adjustment on the POWER MIG® 350MP that allows the welder to adjust the maximum amount of power going to the rear drive motor. The purpose is to send only enough power to the rear drive motor to pull the wire off the spool and get the wire up the torch liner.

STALL FACTOR NUMBER ADJUSTMENT

1. Turn the POWER MIG® 350MP off.
2. Hold the Push-Pull Torch trigger in and turn the power back on. Continue to hold the trigger in while machine powers up.
3. Once the machine displays "SF" in the left display and a number 5 to 40 in the right display the trigger can be released.
4. Use the volts / trim knob to adjust the Stall Factor Number. (It is recommended to start with max value 40)
5. Once the Stall Factor Number is adjusted push the select switch up.
6. The display should scroll the word "SAVEd" if the number was changed. The display will scroll "no CHANGE" if the SF number was not changed.
7. The machine should automatically switch back to normal operation after it is done saving the SF number.

POWER MIG® 350MP "CLEAR ALL" PROCEDURE

1. Hold "select" switch up while powering up machine.
2. Release "select" switch when displays show "Pres sPin".
3. Turn the right "encoder knob" until displays show "Clr All".
4. Toggle the "select" switch up and release.
5. Machine will reset itself.

CAUTION

If for any reason you do not understand the test procedures or are unable to perform the tests/repairs safely, contact your **Local Lincoln Authorized Field Service Facility** for technical troubleshooting assistance before you proceed.

Wiring Diagram Power MIG 350MP CODE: 11827

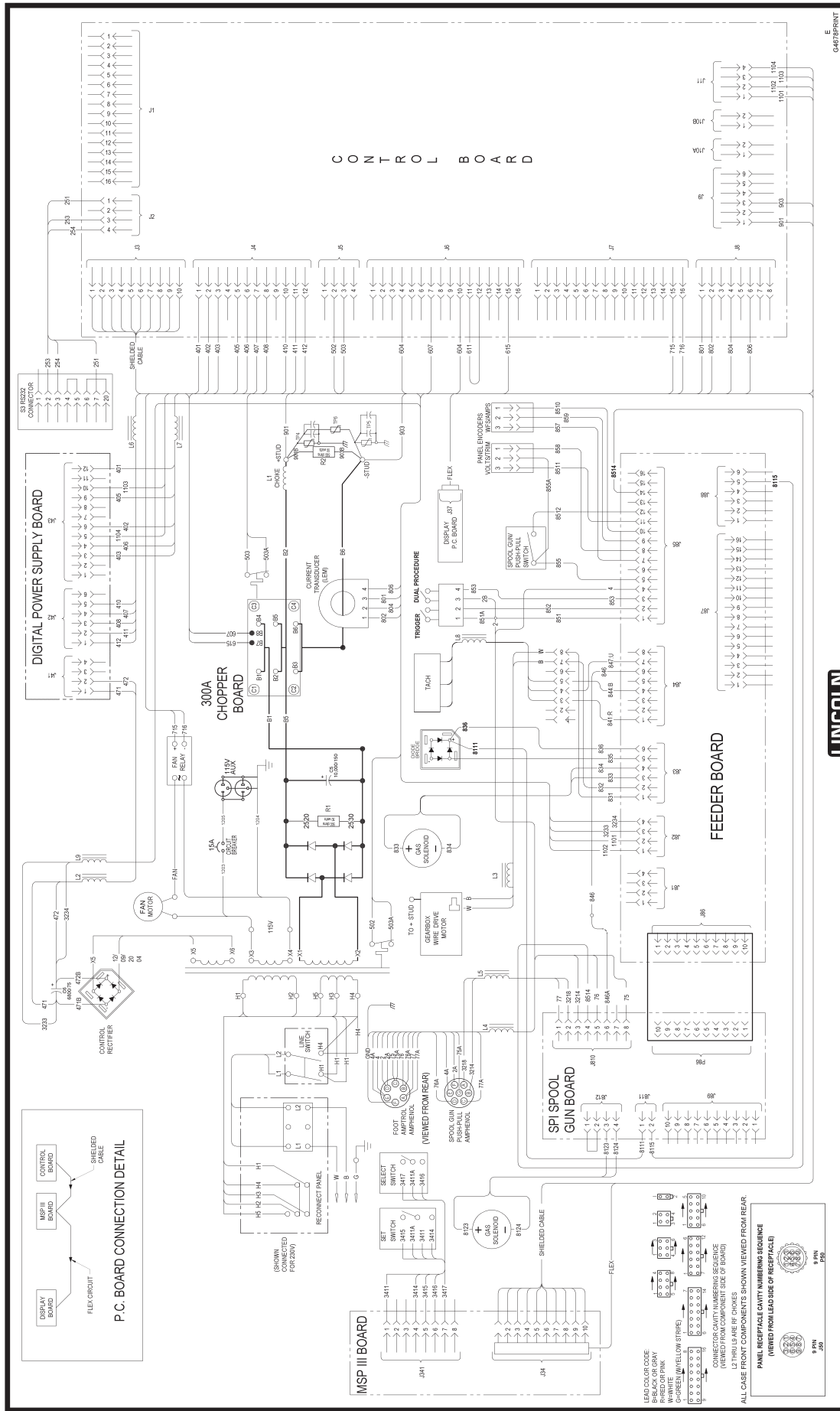

CLEVELAND, OHIO U.S.A.

0467/09/PRINT

NOTE: This diagram is for reference only. It may not be accurate for all machines covered by this manual. The specific diagram for a particular code is pasted inside the machine on one of the enclosure panels. If the diagram is illegible, write to the Service Department for a replacement. Give the equipment code number.

Wiring Diagram Power MIG 350MP CODE: 12875

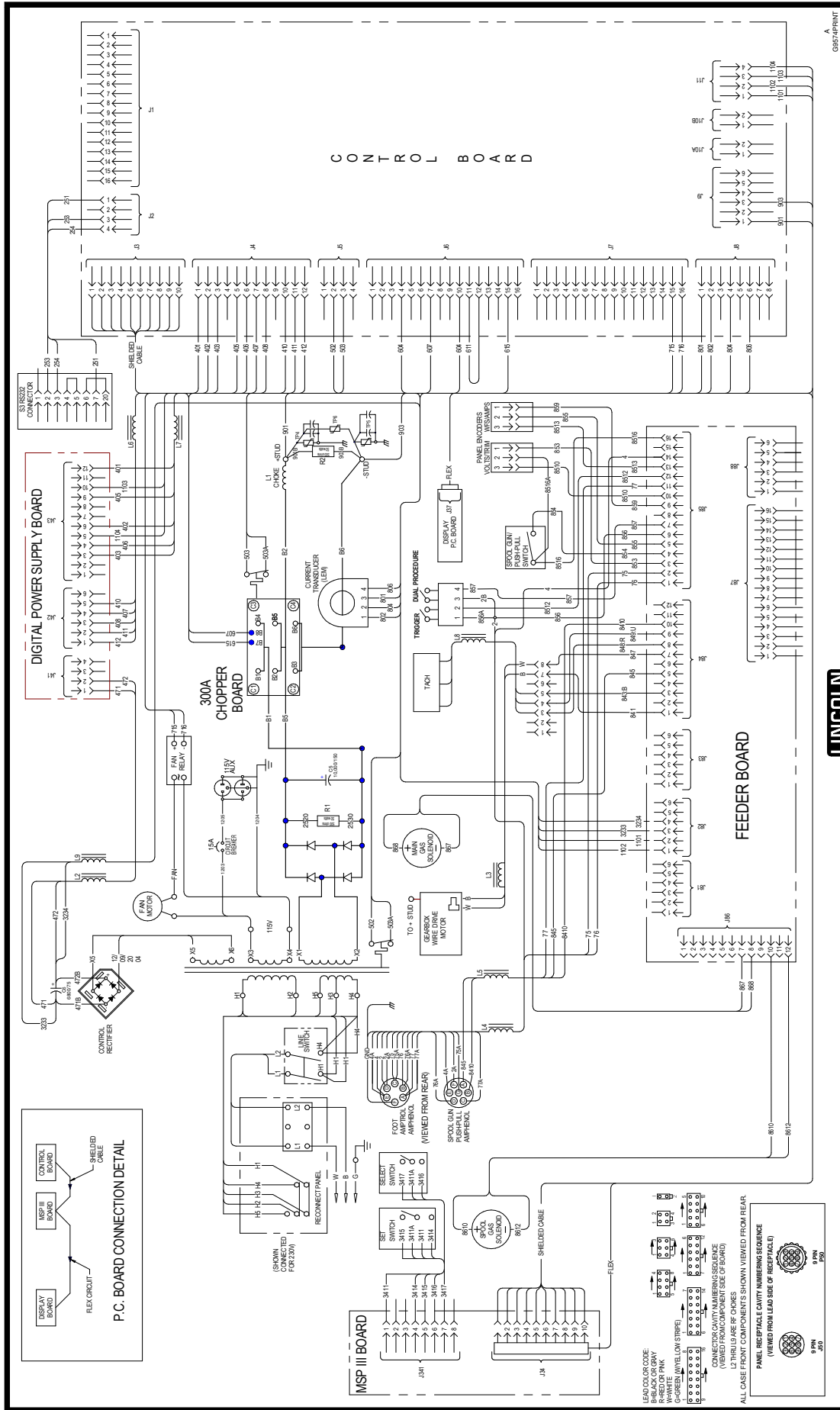

NOTE: This diagram is for reference only. It may not be accurate for all machines covered by this manual. The specific diagram for a particular code is pasted inside the machine on one of the enclosure panels. If the diagram is illegible, write to the Service Department for a replacement. Give the equipment code number.



CLEVELAND, OHIO U.S.A.

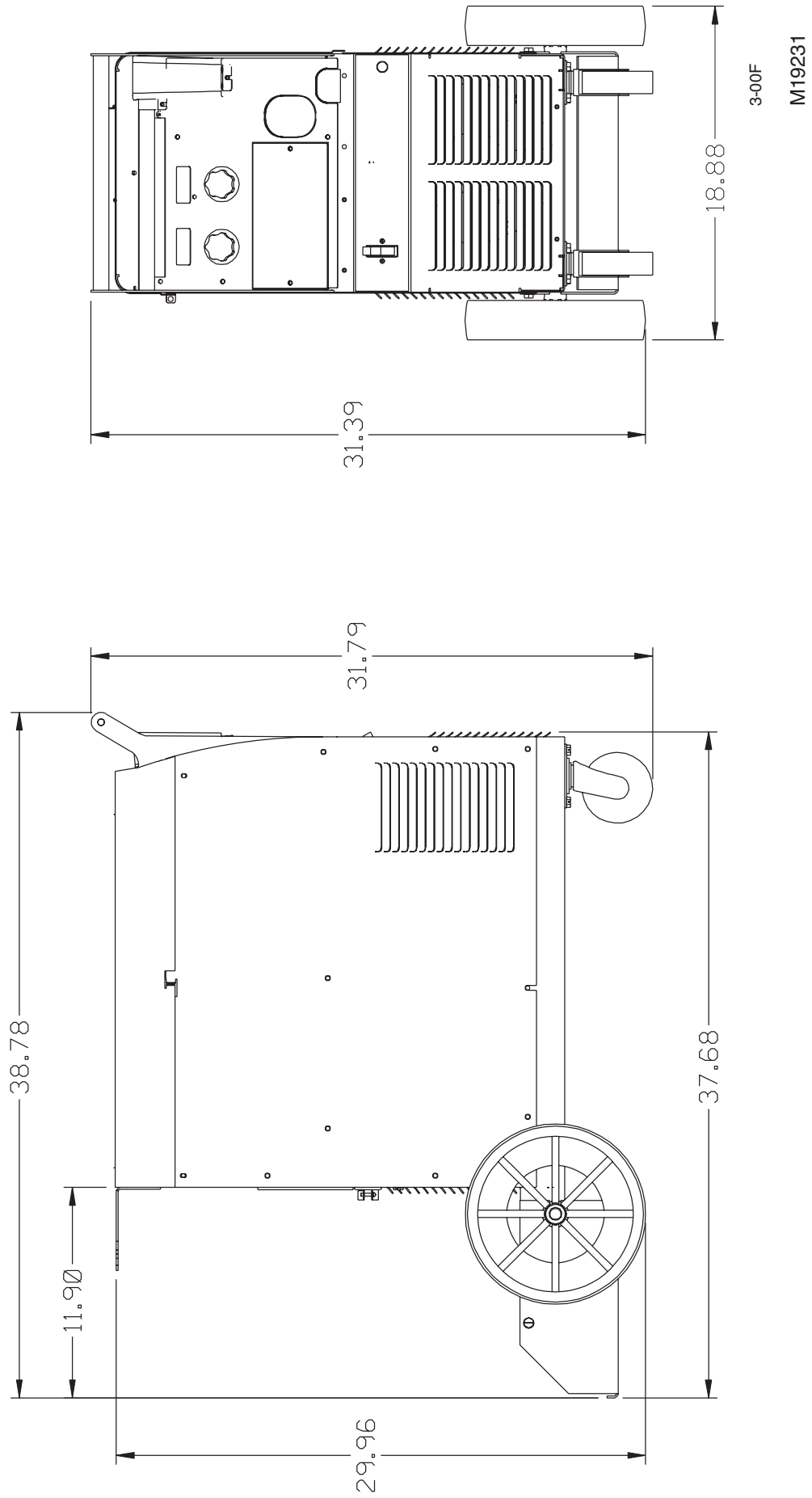

			
WARNING	<ul style="list-style-type: none"> Do not touch electrically live parts or electrode with skin or wet clothing. Insulate yourself from work and ground. 	<ul style="list-style-type: none"> Keep flammable materials away. 	<ul style="list-style-type: none"> Wear eye, ear and body protection.
Spanish AVISO DE PRECAUCION	<ul style="list-style-type: none"> No toque las partes o los electrodos bajo carga con la piel o ropa mojada. Aíslese del trabajo y de la tierra. 	<ul style="list-style-type: none"> Mantenga el material combustible fuera del área de trabajo. 	<ul style="list-style-type: none"> Protéjase los ojos, los oídos y el cuerpo.
French ATTENTION	<ul style="list-style-type: none"> Ne laissez ni la peau ni des vêtements mouillés entrer en contact avec des pièces sous tension. Isolez-vous du travail et de la terre. 	<ul style="list-style-type: none"> Gardez à l'écart de tout matériel inflammable. 	<ul style="list-style-type: none"> Protégez vos yeux, vos oreilles et votre corps.
German WARNUNG	<ul style="list-style-type: none"> Berühren Sie keine stromführenden Teile oder Elektroden mit Ihrem Körper oder feuchter Kleidung! Isolieren Sie sich von den Elektroden und dem Erdboden! 	<ul style="list-style-type: none"> Entfernen Sie brennbares Material! 	<ul style="list-style-type: none"> Tragen Sie Augen-, Ohren- und Körperschutz!
Portuguese ATENÇÃO	<ul style="list-style-type: none"> Não toque partes elétricas e electrodos com a pele ou roupa molhada. Isole-se da peça e terra. 	<ul style="list-style-type: none"> Mantenha inflamáveis bem guardados. 	<ul style="list-style-type: none"> Use proteção para a vista, ouvido e corpo.
Japanese 注意事項	<ul style="list-style-type: none"> 通電中の電気部品、又は溶材にヒフやぬれた布で触れないこと。 施工物やアースから身体が絶縁されている様にして下さい。 	<ul style="list-style-type: none"> 燃えやすいものの側での溶接作業は絶対にしてはなりません。 	<ul style="list-style-type: none"> 目、耳及び身体に保護具をして下さい。
Chinese 警告	<ul style="list-style-type: none"> 皮肤或湿衣物切勿接触带电部件及焊条。 使你自已与地面和工件绝缘。 	<ul style="list-style-type: none"> 把一切易燃物品移离工作场所。 	<ul style="list-style-type: none"> 佩戴眼、耳及身体劳动保护用具。
Korean 위험	<ul style="list-style-type: none"> 전도체나 용접봉을 젖은 헝겍 또는 피부로 절대 접촉치 마십시오. 모재와 접지를 접촉치 마십시오. 	<ul style="list-style-type: none"> 인화성 물질을 접근시키지 마십시오. 	<ul style="list-style-type: none"> 눈, 귀와 몸에 보호장구를 착용하십시오.
Arabic تحذير	<ul style="list-style-type: none"> لا تلمس الاجزاء التي يسري فيها التيار الكهربائي أو الألكترود بجسدك أو بالملابس المبللة بالماء. ضع عازلا على جسمك خلال العمل. 	<ul style="list-style-type: none"> ضع المواد القابلة للاشتعال في مكان بعيد. 	<ul style="list-style-type: none"> ضع أدوات وملابس واقية على عينيك وأذنيك وجسمك.

READ AND UNDERSTAND THE MANUFACTURER'S INSTRUCTION FOR THIS EQUIPMENT AND THE CONSUMABLES TO BE USED AND FOLLOW YOUR EMPLOYER'S SAFETY PRACTICES.

SE RECOMIENDA LEER Y ENTENDER LAS INSTRUCCIONES DEL FABRICANTE PARA EL USO DE ESTE EQUIPO Y LOS CONSUMIBLES QUE VA A UTILIZAR, SIGA LAS MEDIDAS DE SEGURIDAD DE SU SUPERVISOR.

LISEZ ET COMPRENEZ LES INSTRUCTIONS DU FABRICANT EN CE QUI REGARDE CET EQUIPMENT ET LES PRODUITS A ETRE EMPLOYES ET SUIVEZ LES PROCEDURES DE SECURITE DE VOTRE EMPLOYEUR.

LESEN SIE UND BEFOLGEN SIE DIE BETRIEBSANLEITUNG DER ANLAGE UND DEN ELEKTRODENEINSATZ DES HERSTELLERS. DIE UNFALLVERHÜTUNGSVORSCHRIFTEN DES ARBEITGEBERS SIND EBENFALLS ZU BEACHTEN.

			
<ul style="list-style-type: none"> ● Keep your head out of fumes. ● Use ventilation or exhaust to remove fumes from breathing zone. 	<ul style="list-style-type: none"> ● Turn power off before servicing. 	<ul style="list-style-type: none"> ● Do not operate with panel open or guards off. 	WARNING
<ul style="list-style-type: none"> ● Los humos fuera de la zona de respiración. ● Mantenga la cabeza fuera de los humos. Utilice ventilación o aspiración para gases. 	<ul style="list-style-type: none"> ● Desconectar el cable de alimentación de poder de la máquina antes de iniciar cualquier servicio. 	<ul style="list-style-type: none"> ● No operar con panel abierto o guardas quitadas. 	Spanish AVISO DE PRECAUCION
<ul style="list-style-type: none"> ● Gardez la tête à l'écart des fumées. ● Utilisez un ventilateur ou un aspirateur pour ôter les fumées des zones de travail. 	<ul style="list-style-type: none"> ● Débranchez le courant avant l'entretien. 	<ul style="list-style-type: none"> ● N'opérez pas avec les panneaux ouverts ou avec les dispositifs de protection enlevés. 	French ATTENTION
<ul style="list-style-type: none"> ● Vermeiden Sie das Einatmen von Schweißrauch! ● Sorgen Sie für gute Be- und Entlüftung des Arbeitsplatzes! 	<ul style="list-style-type: none"> ● Strom vor Wartungsarbeiten abschalten! (Netzstrom völlig öffnen; Maschine anhalten!) 	<ul style="list-style-type: none"> ● Anlage nie ohne Schutzgehäuse oder Innenschutzverkleidung in Betrieb setzen! 	German WARNUNG
<ul style="list-style-type: none"> ● Mantenha seu rosto da fumaça. ● Use ventilação e exaustão para remover fumo da zona respiratória. 	<ul style="list-style-type: none"> ● Não opere com as tampas removidas. ● Desligue a corrente antes de fazer serviço. ● Não toque as partes elétricas nuas. 	<ul style="list-style-type: none"> ● Mantenha-se afastado das partes moventes. ● Não opere com os painéis abertos ou guardas removidas. 	Portuguese ATENÇÃO
<ul style="list-style-type: none"> ● ヒュームから頭を離すようにして下さい。 ● 換気や排煙に十分留意して下さい。 	<ul style="list-style-type: none"> ● メンテナンス・サービスに取りかかる際には、まず電源スイッチを必ず切して下さい。 	<ul style="list-style-type: none"> ● パネルやカバーを取り外したまま機械操作をしないで下さい。 	Japanese 注意事項
<ul style="list-style-type: none"> ● 頭部遠離煙霧。 ● 在呼吸區使用通風或排風器除煙。 	<ul style="list-style-type: none"> ● 維修前切斷電源。 	<ul style="list-style-type: none"> ● 儀表板打開或沒有安全罩時不準作業。 	Chinese 警告
<ul style="list-style-type: none"> ● 얼굴로부터 용접가스를 멀리하십시오. ● 호흡지역으로부터 용접가스를 제거하기 위해 가스제거기나 통풍기를 사용하십시오. 	<ul style="list-style-type: none"> ● 보수전에 전원을 차단하십시오. 	<ul style="list-style-type: none"> ● 판넬이 열린 상태로 작동치 마십시오. 	Korean 위험
<ul style="list-style-type: none"> ● ابعد رأسك بعيداً عن الدخان. ● استعمل التهوية أو جهاز ضغط الدخان للخارج لكي تبعد الدخان عن المنطقة التي تتنفس فيها. 	<ul style="list-style-type: none"> ● اقطع التيار الكهربائي قبل القيام بأية صيانة. 	<ul style="list-style-type: none"> ● لا تشغيل هذا الجهاز اذا كانت الاغطية الحديدية الواقية ليست عليه. 	Arabic تحذير

LEIA E COMPREENDA AS INSTRUÇÕES DO FABRICANTE PARA ESTE EQUIPAMENTO E AS PARTES DE USO, E SIGA AS PRÁTICAS DE SEGURANÇA DO EMPREGADOR.

使う機械や溶材のメーカーの指示書をよく読み、まず理解して下さい。そして貴社の安全規定に従って下さい。

請詳細閱讀並理解製造廠提供的說明以及應該使用的銀焊材料，並請遵守貴方的有關勞動保護規定。

이 제품에 동봉된 작업지침서를 숙지하시고 귀사의 작업자 안전수칙을 준수하시기 바랍니다.

اقرأ بتمعن وافهم تعليمات المصنع المنتج لهذه المعدات والمواد قبل استعمالها واتبع تعليمات الوقاية لصاحب العمل.

CUSTOMER ASSISTANCE POLICY

The business of The Lincoln Electric Company is manufacturing and selling high quality welding equipment, consumables, and cutting equipment. Our challenge is to meet the needs of our customers and to exceed their expectations. On occasion, purchasers may ask Lincoln Electric for advice or information about their use of our products. We respond to our customers based on the best information in our possession at that time. Lincoln Electric is not in a position to warrant or guarantee such advice, and assumes no liability, with respect to such information or advice. We expressly disclaim any warranty of any kind, including any warranty of fitness for any customer's particular purpose, with respect to such information or advice. As a matter of practical consideration, we also cannot assume any responsibility for updating or correcting any such information or advice once it has been given, nor does the provision of information or advice create, expand or alter any warranty with respect to the sale of our products.

Lincoln Electric is a responsive manufacturer, but the selection and use of specific products sold by Lincoln Electric is solely within the control of, and remains the sole responsibility of the customer. Many variables beyond the control of Lincoln Electric affect the results obtained in applying these types of fabrication methods and service requirements.

Subject to Change – This information is accurate to the best of our knowledge at the time of printing. Please refer to www.lincolnelectric.com for any updated information.



THE LINCOLN ELECTRIC COMPANY
22801 St. Clair Avenue • Cleveland, OH • 44117-1199 • U.S.A.
Phone: +1.216.481.8100 • www.lincolnelectric.com