

General Notes:

- Codes 10865, 11034 & 11036 do not support the high/low speed gear change. Only the high speed (1.8" diameter) gear may be used.

Error Code	Description	Cause and Remedy
Err 0081	Average motor Over-current shutdown	The wire drive has exceeded the current rating: <ul style="list-style-type: none"> 10 amps for 0.5 seconds or 3.5 amps for 10 seconds. Wait 45 seconds for the error to reset. Reduce the current load on the motor by: <ul style="list-style-type: none"> Verifying the electrode slides easily through the liner of the gun. Reduce the spindle brake resistance. Reduce the amount of tension in the wire drive pressure arm. Use only Lincoln electrodes.
Err 0086	Trigger lockout	The voltage into the feed head board exceeds 150 VDC. This error should never occur on the Control Cable LN-15 because it gets its power from rectified 42 VAC (approx. 62 VDC).

Platform	Ranger 8/Ranger 9	Classic	Ranger 250, 305 Commander 300,400,500 (Common Analog Controls)	V350 (Common Digital Controls)	DC-400, 600	Square Wave TIG 300/355	STT II
K1871-1,-2 Control Cable	N.A. The Ranger 8 does not have a 14 pin remote.	Requires Wire Feed Module and 42VAC transformer kit	Recommended for CV and CC operation.	Recommended for CV, Pulse and CC operation.	Recommended for CV and CC operation.	N.A. The SQ TIG 300/355 does not have a 14 pin remote.	Recommended for STT operation

Note: Most semiautomatic wire welding processes perform better using constant voltage power sources. Be sure the proper power source is used for your application.

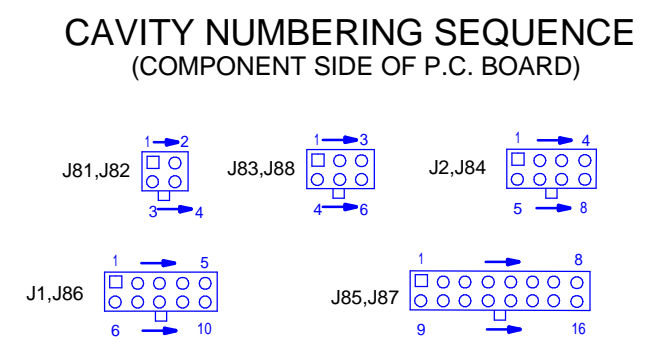

GENERAL INFORMATION

ELECTRICAL SYMBOLS PER E1537

COLOR CODE	BLACK
B -	BLACK
W -	WHITE
R -	RED
U -	BLUE

LN-15 CONTROL CABLE MODEL

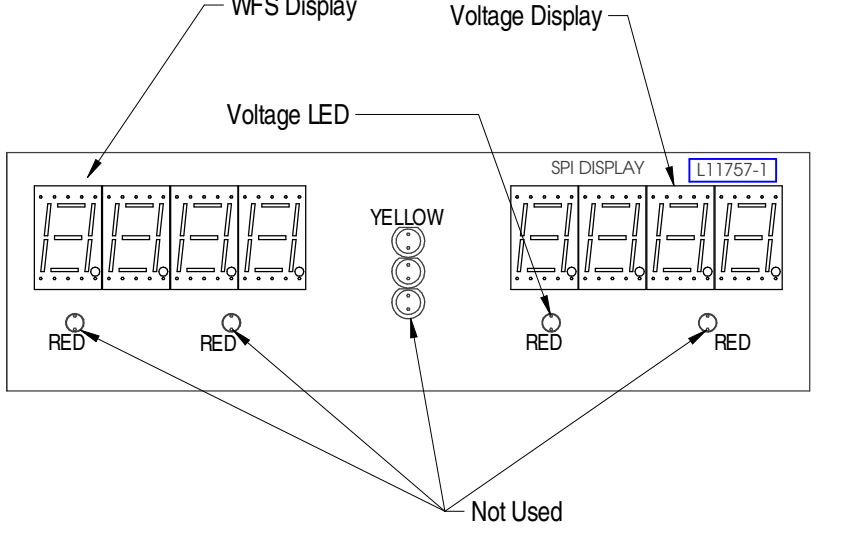
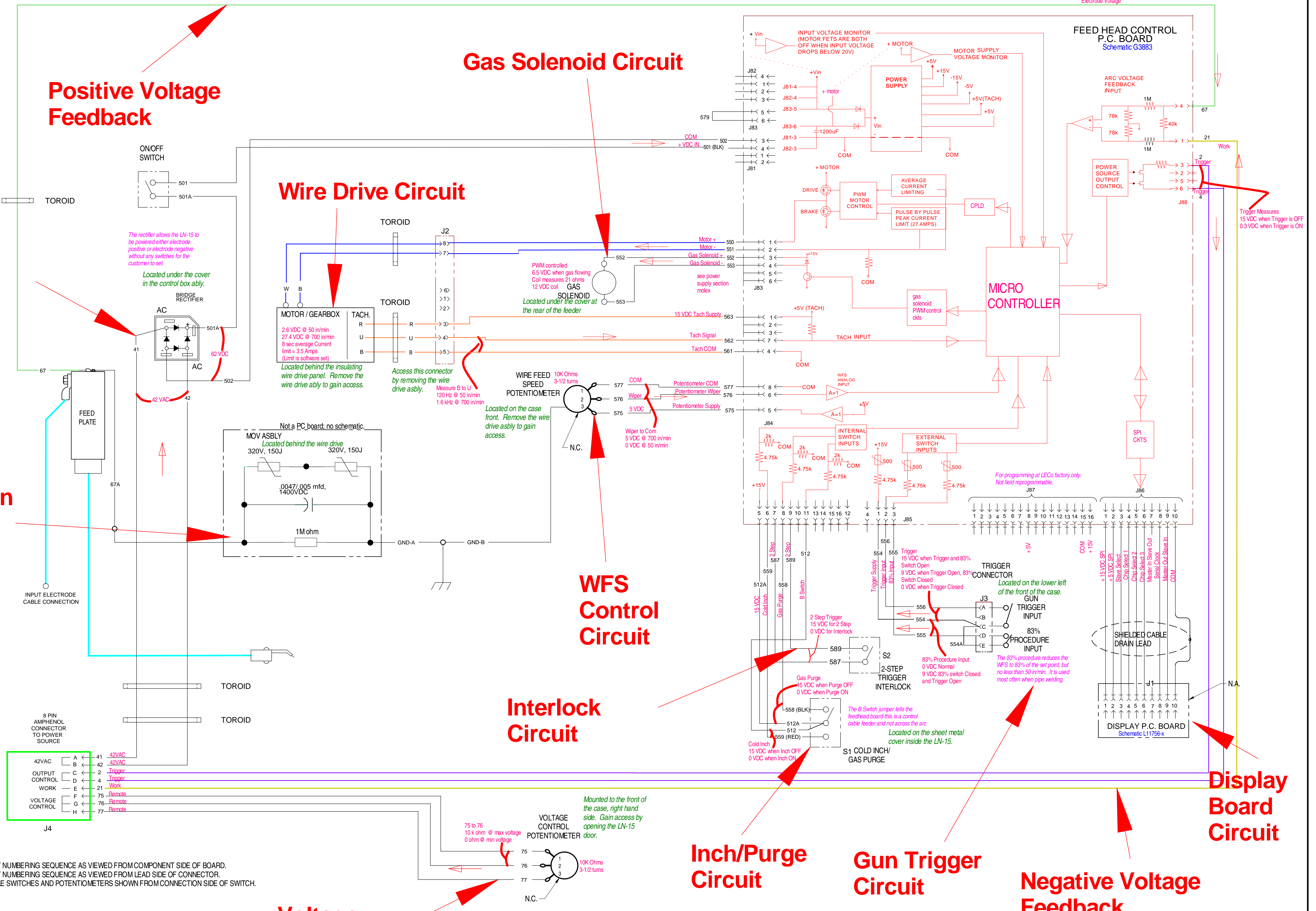

The display board communicates to the feedhead board through the SPI bus. Only the power supply signals can be monitored during servicing.

The WFS always shows the present WFS.

The voltage display shows the voltage while welding, plus holds the voltage for 5 seconds after the weld. It shows "--" when idle. A negative "-" sign will automatically be shown when welding with reverse polarity procedures.

All the LEDs, including those not used, will briefly light on power up. The LED's not used are visible behind the nameplate when lit.

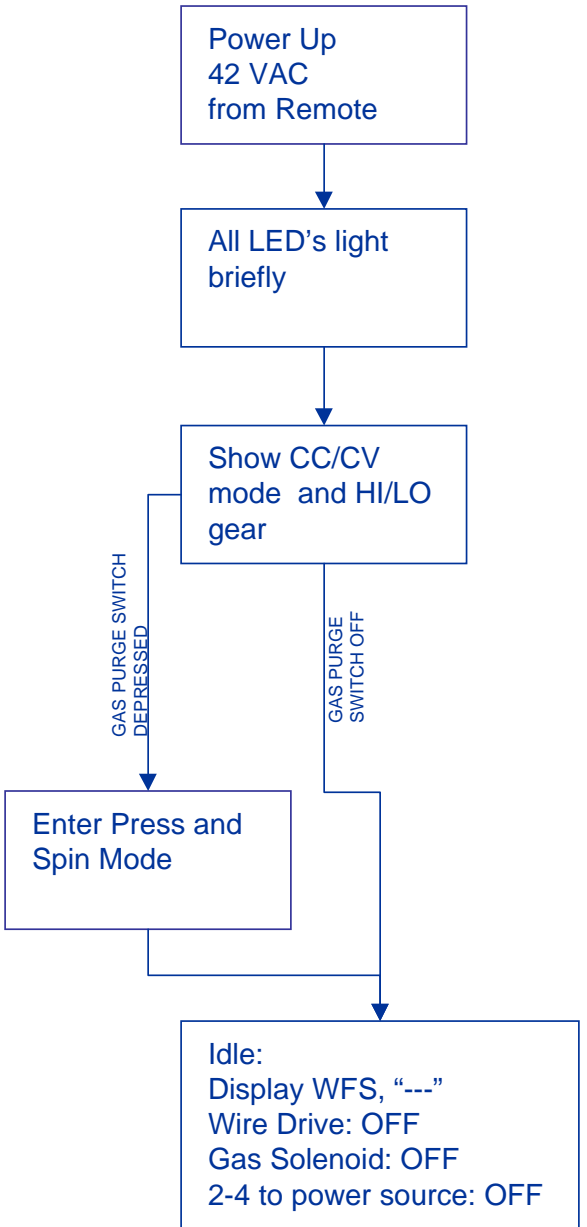

N.A. CAVITY NUMBERING SEQUENCE AS VIEWED FROM COMPONENT SIDE OF BOARD.
 N.B. CAVITY NUMBERING SEQUENCE AS VIEWED FROM LEAD SIDE OF CONNECTOR.
 N.C. TOGGLE SWITCHES AND POTENTIOMETERS SHOWN FROM CONNECTION SIDE OF SWITCH.