

# SQUARE WAVE TIG 175 WIRING DIAGRAM L15798 REV: A

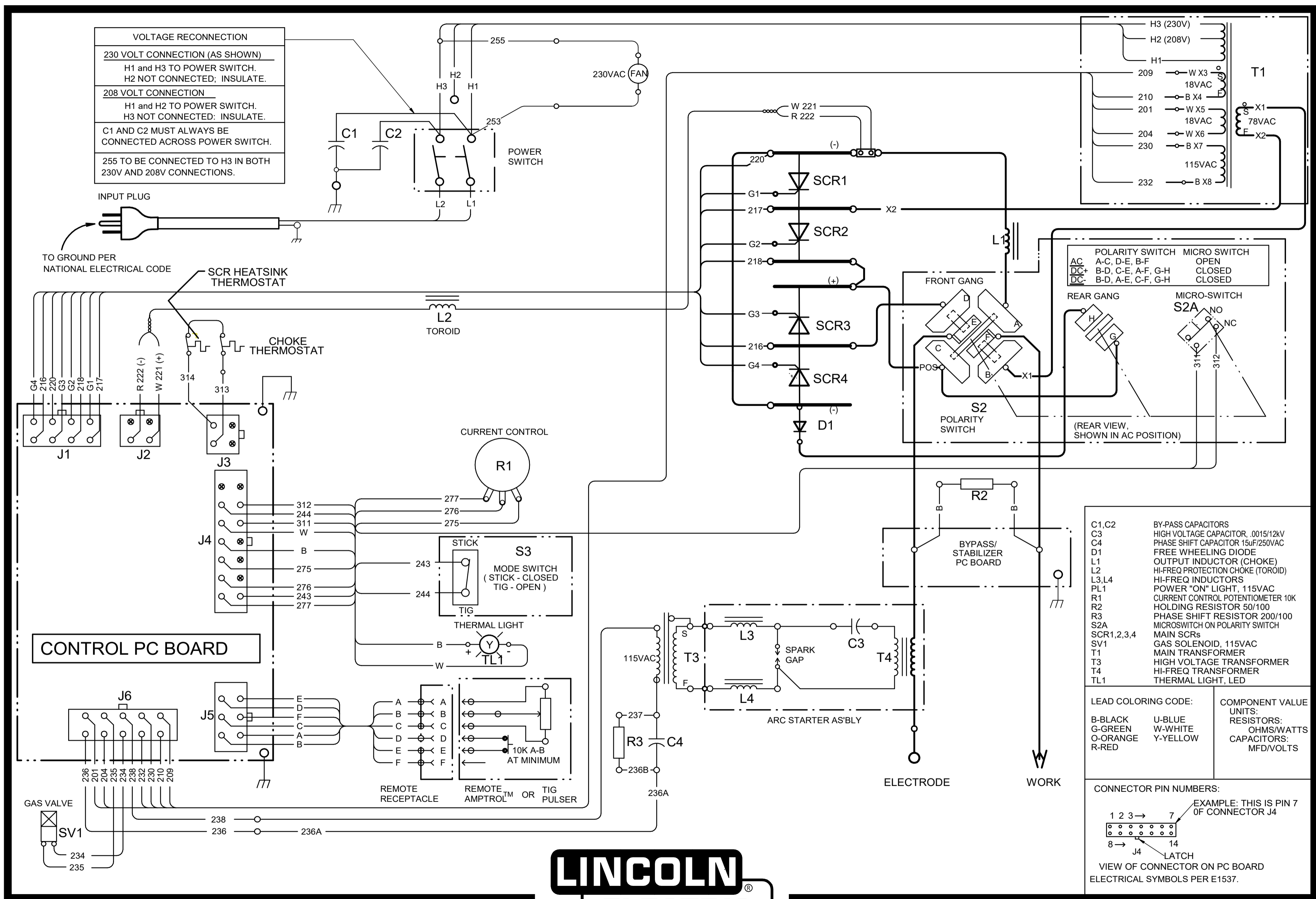

**VOLTAGE RECONNECTION**

**230 VOLT CONNECTION (AS SHOWN)**  
H1 and H3 TO POWER SWITCH.  
H2 NOT CONNECTED; INSULATE.

**208 VOLT CONNECTION**  
H1 and H2 TO POWER SWITCH.  
H3 NOT CONNECTED; INSULATE.

C1 AND C2 MUST ALWAYS BE CONNECTED ACROSS POWER SWITCH.

255 TO BE CONNECTED TO H3 IN BOTH 230V AND 208V CONNECTIONS.

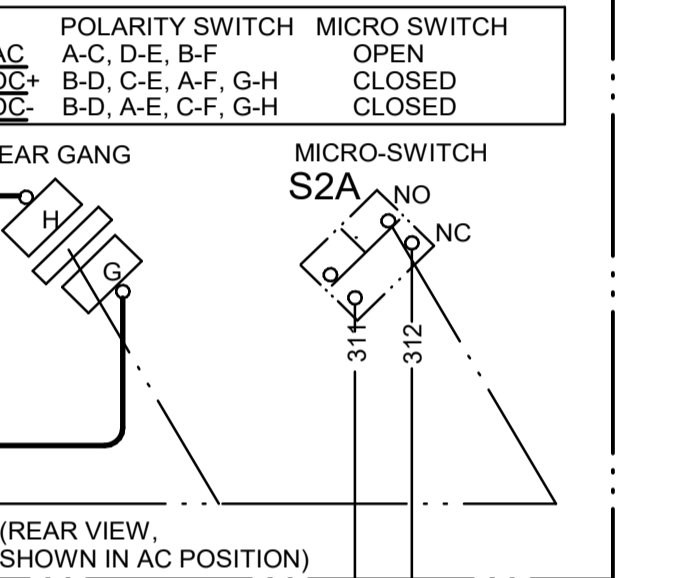
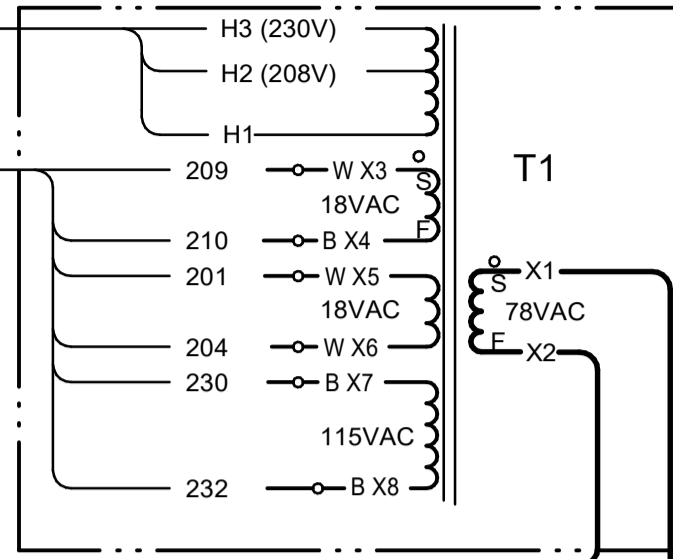

- C1, C2 BY-PASS CAPACITORS
- C3 HIGH VOLTAGE CAPACITOR, .0015/12kV
- C4 PHASE SHIFT CAPACITOR 15uF/250VAC
- D1 FREE WHEELING DIODE
- L1 OUTPUT INDUCTOR (CHOKE)
- L2 HI-FREQ PROTECTION CHOKE (TOROID)
- L3, L4 HI-FREQ INDUCTORS
- PL1 POWER "ON" LIGHT, 115VAC
- R1 CURRENT CONTROL POTENTIOMETER 10K
- R2 HOLDING RESISTOR 50/100
- R3 PHASE SHIFT RESISTOR 200/100
- S2A MICROSWITCH ON POLARITY SWITCH
- SCR1,2,3,4 MAIN SCRS
- SV1 GAS SOLENOID, 115VAC
- T1 MAIN TRANSFORMER
- T3 HIGH VOLTAGE TRANSFORMER
- T4 HI-FREQ TRANSFORMER
- TL1 THERMAL LIGHT, LED

LEAD COLORING CODE:		COMPONENT VALUE UNITS: RESISTORS: OHMS/WATTS CAPACITORS: MFD/VOLTS
B-BLACK	U-BLUE	
G-GREEN	W-WHITE	
O-ORANGE	Y-YELLOW	
R-RED		

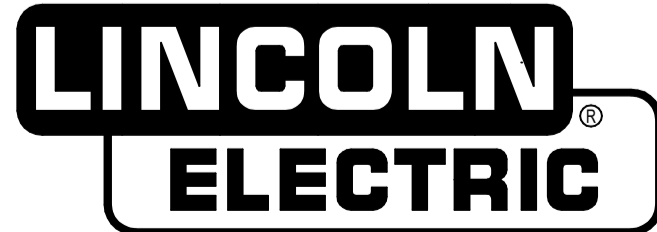
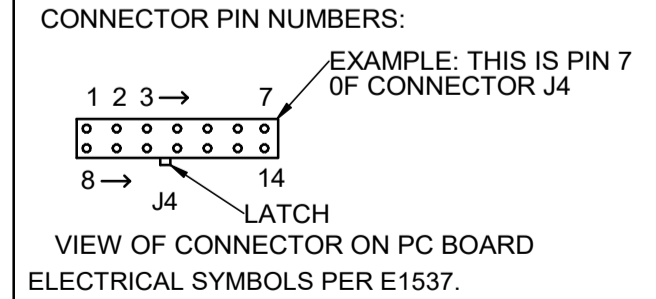

CLEVELAND, OHIO U.S.A.