

**90 AMP MIG WELDER - SERIES A**

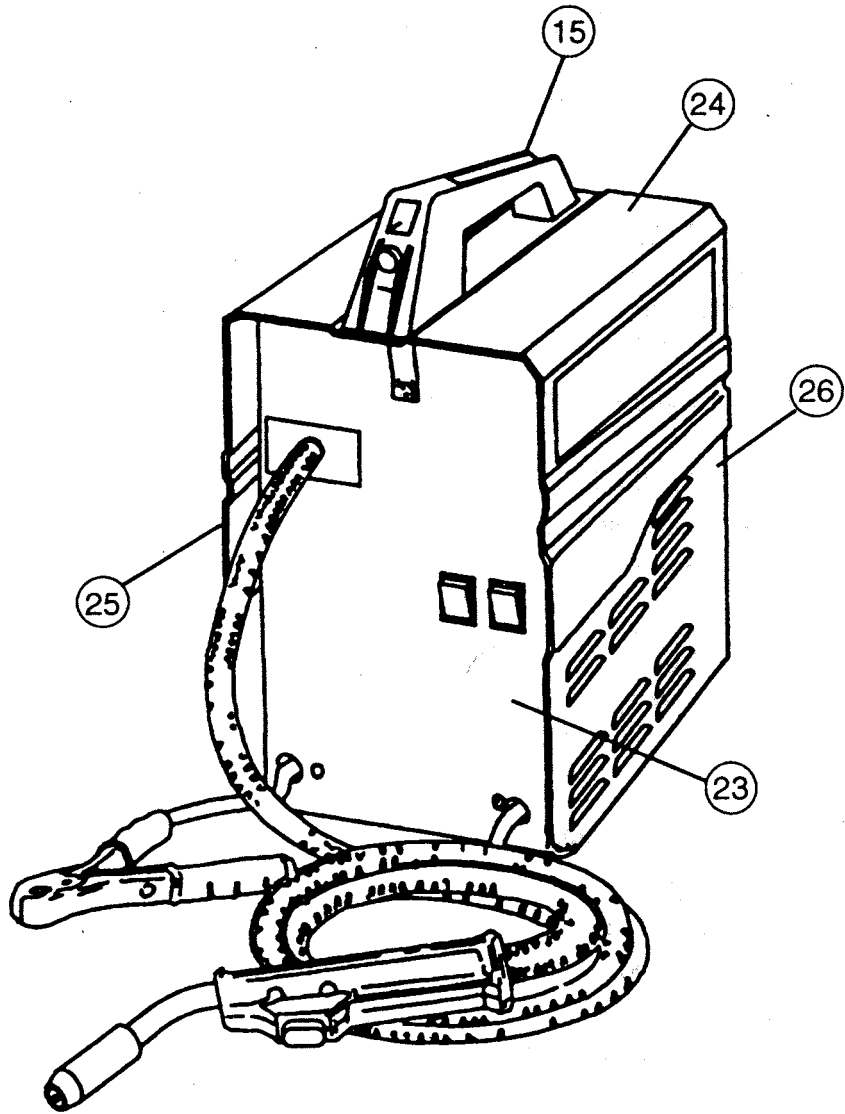

One Lincoln Way  
St. Louis, Missouri 63120-1578  
Customer Service (314) 679-4300

Copyright 1996  
Printed in U.S.A.

**Mig Section**

# CONTENTS

---

	INSTRUCTION MANUAL FOR GAS/NO GAS WIRE WELDER . . . . .	page 3
	PROTECTION FROM ELECTRICAL SHOCK . . . . .	.4
	FLAMMABLE AND EXPLOSIVE MATERIALS . . . . .	.4
	PREVENTATIVE MAINTENANCE . . . . .	.4
1.0	INTRODUCTION . . . . .	.5
2.0	SAFETY RULES . . . . .	.5
	PERSONAL PROTECTION . . . . .	.5
	FIRE PREVENTION . . . . .	.5
	ELECTRICAL SHOCK . . . . .	.6
	VENTILATION . . . . .	.7
	FLAMMABLE AND EXPLOSIVE MATERIALS . . . . .	.7
3.0	OPERATING INSTRUCTIONS . . . . .	.7
	ELECTRICAL REQUIREMENT . . . . .	.7
	SERVICING AND USEFUL HINTS . . . . .	.8
4.0	USER MANUAL . . . . .	.8
	CONNECTION TO ELECTRIC MAINS . . . . .	.8
	SETUP . . . . .	.8
	HELPFUL HINTS . . . . .	.8
	GENERAL MAINTENANCE . . . . .	.8
	ELECTRIC DIAGRAM . . . . .	.9
	SPARE PARTS LIST . . . . .	10
	WIRE FEED UNIT . . . . .	11
	LIMITED WARRANTY . . . . .	12

# INSTRUCTION MANUAL FOR GAS/NO GAS WIRE WELDER

## WARNING

1. Read study and understand all warnings and operating instructions furnished with this equipment prior to installation or use. If any part of this material is unclear contact the factory for clarification.
2. Only qualified persons are to install, operate, and maintain this equipment in accordance with applicable codes, safety practices and manufacturer's instructions.
3. Electric shock can be fatal; therefore:
  - a. Install and ground unit in compliance with national, regional and local codes.
  - b. Protect yourself with dry, insulated gloves and clothing.
  - c. Insure that workpiece is grounded prior to activating torch.
  - d. Do not operate in damp or wet area.
4. Arc rays can injure eyes and burn skin; therefore:
  - a. Always wear welding eye shield with proper filter lens.
  - b. Wear appropriate protective clothing to cover exposed skin.
  - c. Make sure bystanders are also protected from arc rays when operating this unit.
5. Fumes and gases can be seriously harmful to your health; therefore:
  - a. Operate this equipment in well ventilated area. If this is not possible use air-supplied breathing apparatus.
  - b. Welding of containers can result in poisonous fumes. Insure all containers are empty and properly cleaned prior to welding.
6. Hot metal slag and sparks may cause fire, burns and explosions; therefore:
  - a. Do not operate in explosive atmosphere such as one containing paint, solvent, degreaser or gasoline fumes.
  - b. Do not operate near combustible materials.
  - c. Have appropriate fire extinguisher available and know how to use it.
  - d. Allow workpiece to cool before handling.
  - e. It is recommended that a person other than the operator be assigned to observe the welding operation to watch for fire.
7. Refer to the Operator's Manual supplied with this equipment for a listing of additional safety publications available.
8. It is the owner's responsibility to keep all warning decals legible and intact. Replacement decals are available from the factory.
9. Failure to heed these warnings may result in personal or fatal injury and/or equipment and property damage.

## DANGER

Read and observe all instructions included in this manual as well as these following specific procedures.

### EYE AND BODY PROTECTION

**WARNING: Never look at welding arc without a helmet or shield. Arc rays are extremely dangerous to the eyes.**

1. Use helmet filter and cover plate complying with ANSI Z87.1 to protect your eyes and face from sparks and the rays of the arc when welding or observing open arc welding.
2. Always wear safety goggles with side shields complying with ANSI Z87.1 when in a welding area or when near slag chipping operation.
3. To avoid spatter and ultraviolet ray burns wear oil free woolen clothing keep sleeves and collars buttoned no pockets in front cuffless trousers overlapping high shoes and leather gauntlet gloves.
4. Protect other near-by personnel with suitable non-flammable screening, and warn bystanders as to the potential hazards in the weld area.
5. Provide adequate ventilation in the welding area, particularly when welding on galvanized lead or cadmium plated steel, and other metal which produce toxic fumes.
6. When working above floor level protect yourself from a fall should you get a shock. Never wrap the electrode cable around any part of your body.

Do not weld in locations close to chlorinated hydro-carbon vapors coming from degreasing, cleaning, or spraying operations. The ultraviolet rays of the arc can react with solvent vapors to form phosgene, a highly toxic gas, and other gases.

### PROTECTION FROM ELECTRICAL SHOCK

1. Do not let bare skin or wet clothing come between the following combinations:

Welding Gun  
AND  
Ground Clamp, or Workpiece,  
or Metal Work Table

40 volts exist between these parts when welder is on and gun trigger pressed!

Wear dry, hole free, clothing and gauntlet type gloves to protect and insulate the body.

2. Take special care to insulate yourself from ground using dry insulation (such as dry wood) of adequate size when welding in damp locations, on metal floors or gratings, and in positions (such as sitting or lying) where parts or large areas of your body can be in contact with possible grounds.
3. Maintain the electrode holder, work clamp, welding cable and welding machine in good, safe operating condition.

### FLAMMABLE AND EXPLOSIVE MATERIALS

1. Remove flammable and explosive material at least 35 feet from the welding arc to prevent welding sparks or molten metal from starting a fire. Keep a type ABC fire extinguisher within easy reach.
2. Welding on or near containers which hold combustibles can cause an explosion, even when they have been cleaned. For information purchase "Safe Practices for Welding and Cutting Containers that Have Held Combustibles"

(F4.1) from the American Welding Society AWS, 550 N.W. Lejeune Rd Miami, Florida 33126.

3. Electrodes shall be removed from electrode holders when not in use, and holders shall be so placed that they cannot make electrical contact with persons, conducting objects, flammable liquids, or compressed gas cylinders.
4. Never connect the work cable or clamp to any object but the work piece or metal work table. Connecting to other objects such as building ground can create a fire hazard.
5. Never weld anything on or to the welder cabinet, as a burn through may cause transformer failure.

### PREVENTATIVE MAINTENANCE

1. Never apply power to the welder with any part of the "cabinet" removed. Position on-off switch in "Off" position and disconnect power supply at the circuit breaker or fuse box before doing maintenance work inside the machine.
2. Before connecting the welder power cord to the receptacle, check the following:
  - a. Inspect the power cord and welding cables for cuts or burns and make sure blades and ground pin on the plug are straight.
  - b. Inspect "On-Off" switch lever for cracks or broken parts.
  - c. Inspect electrode holder jaw insulators for cracks or broken parts.
  - d. For additional safety information, purchase copies of "Practice for Occupational and Educational Eye & Face Protection" (ANSI Z87.1) and "Safety in Welding and Cutting" (ANSI Z49.1) from the American Welding Society or the American National Standards Institute ANSI, 1430 Broadway, New York, New York 10018, and "Code for Safety in Welding and Cutting" (CSA Standard W117.2-1574) from the Canadian Standards Association, 178 Rexdale Blvd., Rexdale, Ontario M9W1R3.

### INTRODUCTION

This manual is meant to describe the correct use of the welder and to inform you about the basics of welding techniques.

Therefore, please read the following directions carefully.

One of the best known systems which has made it possible for users, even for unskilled ones, to produce excellent welds as well as to join with ease materials considered hard to be welded, is the process based on a continued fed wire with gas shielding, commonly known as MIG. Also there is a method of wire welding that uses a flux cored wire instead of gas. This machine can use this self-shielding wire by making the proper adjustments, or if desired, use normal gas shielding.

The welder you have bought has been conceived and simplified in such a way as to be practical, easy to operate, light and transportable with one hand.

It gives excellent performances on mild steel, stainless steel and aluminum.

Furthermore, the welder we supply is equipped with what is necessary to weld mild steel with self-shielding cored wire. If gas shielding is desired, the gas bottle is available at a welding distributor.

Gasless welding is limited to steel of 18 gauge or thicker, and the weld process leaves some slag and spatter.

## 1.0 INTRODUCTION

Your new welder has been sturdily constructed and is a thoroughly tested machine. It has been engineered to give you many years of efficient troublefree service and satisfaction. It is a normal characteristic of this unit to hum or buzz during normal operation.

We recommend that you read through this manual at least once to learn the features of your new machine and to refresh your knowledge about the important safety precautions you must always follow. If you are not particularly experienced, this manual will inform you of the correct and safe procedures to follow when using your welder.

## 2.0 SAFETY RULES

### PERSONAL PROTECTION

Use a proper face shield fitted with the correct filter and cover plates to protect your eyes, face, neck and ears from sparks and rays of the welding arc when welding or observing welding. WARN bystanders not to watch the arc and not to expose themselves to the welding-arc rays or to hot metal.

Wear flameproof gauntlet-type gloves, heavy long-sleeve shirt, cuffless trousers, high-topped shoes and a welding helmet or cap for hair protection to protect the skin from arc rays and hot sparks or hot metal. A flameproof leather or asbestos apron may also be desirable as protection against radiated heat and sparks.

Hot sparks or metal can lodge in rolled up sleeves, trouser cuffs or pockets. Sleeves and collars should be kept buttoned, and pockets eliminated from the front.

All Safety Precautions as per ANSI Standards:

Z87.1 Practice for Occupational and Educational Eye and Face Protection.

Z49.1 Safety in Welding and Cutting.

### FIRE PREVENTION

**WARNING:** Hot slag, sparks, or metal can cause serious fires when in contact with combustible solids, liquids or gases.



▲ Always wear safety goggles when in a welding area.

▲ Use safety glasses with side shields or goggles when chipping slag or grinding.

▲ Chipped slag is hot and may travel considerable distances. Bystanders should also wear safety glasses or goggles.

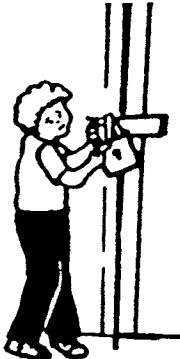

▲ Make workshop kidproof—with padlocks, master switches, or by removing starter keys.

▲ Keep children away. All visitors should be kept a safe distance from work area.

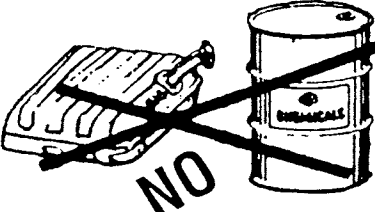

▲ Remove all combustible materials well away from the welding area. Such combustible materials include wood, clothing, sawdust, gasoline, kerosene, paints, solvents, natural gas, acetylene, propane and similar combustible articles.

1. Hot sparks or hot metal can fall into cracks in floors or wall openings and cause a hidden smoldering fire. Make certain that such openings are protected from hot sparks and metal.
2. Do not weld, cut, or perform other hot work on used barrels, drums, tanks or other containers until they have been completely cleaned so that there are no substances in the container which might produce flammable or toxic vapors.
3. After completion of welding or hot work, inspect the work area to make certain that there are no hot sparks or hot metal which could cause a later fire.
4. Keep work area clean. Cluttered areas and benches invite accidents.
5. Don't overreach. Keep your proper footing and balance at all times.

## ELECTRICAL SHOCK

**WARNING:** Voltage of 110 volts or less can cause severe burns to the body or fatal shock. Severity of electrical shock is determined by the path and amount of current through the body.

1. Never allow live metal parts of an electrode holder to touch bare skin or any wet clothing. Be sure gloves are dry.
2. When standing on metal or welding in a damp area, make certain that you are well insulated from the ground by wearing dry gloves and rubber-soled shoes and standing on a dry board or platform.
3. When working above floor level, protect yourself from a fall should you get a shock. Never wrap the electrode cable around any part of your body.
4. Always connect the welder to a grounded outlet having the correct voltage. Welder is equipped with three-prong plug, it should be plugged into a three-hole electrical receptacle.
5. Keep your work area well illuminated.
6. Do not use bare, taped or overloaded welding cables. Use a well maintained electrode holder and ground clamp. Never cool the holder by dipping into water.
7. When not welding, place the electrode holder where it is insulated from the ground system. Accidental grounding can cause overheating and create a fire hazard. Do not coil or loop the welding cable around parts of the body.
8. Be sure the ground cable is connected to the workpiece as close to the welding area as possible.
9. Keep everything dry, including work clothing, work area, welding cables, electrode holder and welding machine.
10. Disconnect welder before servicing and when changing accessories.
11. Avoid accidental starting. Make sure switch is OFF before plugging in cord.
12. Secure work. Use clamps or a vise to hold work, when practical. It's safer than using your hand, frees both hands to operate welder.

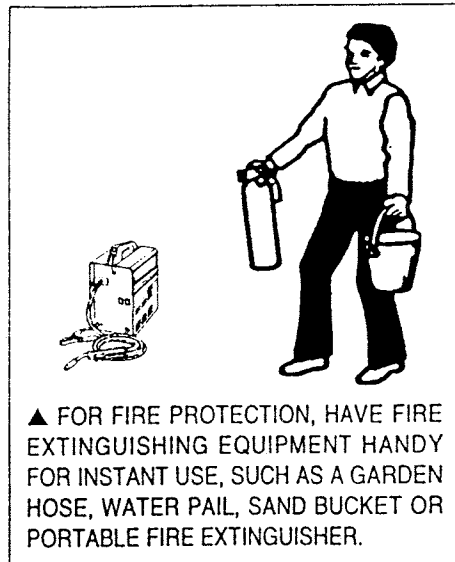

## VENTILATION

**WARNING:** Welding fumes, particularly in confined spaces, can cause discomfort and physical harm if breathed over an extended period of time.

Provide adequate ventilation in the welding area at all times by natural ventilation or mechanical ventilation. Do not weld on galvanized, zinc, lead, beryllium or cadmium materials unless positive mechanical ventilation is provided to prevent breathing fumes from these materials.

Do not weld in locations close to chlorinated hydrocarbon vapors coming from degreasing or spraying operations. The heat or arc rays can react with solvent vapors to form phosgene, a highly toxic gas, and other irritant gases.

If you develop momentary eye, nose or throat irritation during welding, it is an indication that ventilation is not adequate. Stop work and take necessary steps to improve ventilation in the welding area. Do not continue to weld if physical discomfort persists.



## FLAMMABLE AND EXPLOSIVE MATERIALS

1. Remove flammable and explosive material at least 35 feet from the welding arc to prevent welding sparks or molten metal from starting a fire. Keep a type ABC fire extinguisher within easy reach.
2. Welding on or near containers which hold combustibles can cause an explosion, even when they have been cleaned. For information purchase "Safe Practices for Welding and Cutting Containers that Have Held Combustibles" (F4.1) from the American Welding Society AWS, 550 N.W. Lejeune Rd Miami, Florida 33126.
3. Electrodes shall be removed from electrode holders when not in use, and holders shall be so placed that they cannot make electrical contact with persons, conducting objects, flammable liquids, or compressed gas cylinders.
4. Never connect the work cable or clamp to any object but the work piece or metal work table. Connecting to other objects such as building ground can create a fire hazard.
5. Never weld anything on or to the welder cabinet, as a burn through may cause transformer failure.

## 3.0 OPERATING INSTRUCTIONS

### ELECTRICAL REQUIREMENTS

It is recommended that a separate circuit be provided for the welder. For best results, the circuit should be protected by a 20 ampere time delay fuse or circuit breaker.

The voltage, cycles and current must correspond to the information on the welder face plate.

The installation must comply with the local electrical code requirements.

Where the proper receptacle is not installed, we strongly recommend that a properly grounded three-prong wall receptacle be installed by a qualified electrician in accordance with the National Electrical Code and local codes and ordinances.

**WARNING:** This welder must be grounded while in use to protect the operator from electrical shock. If you are not sure that your outlet is properly grounded, have it checked by a qualified electrician. Do not cut off grounding prong or alter plug in any way.

The weld is equipped with a 20 Amp three-prong plug on the power supply cord, which must be plugged into a properly grounded 20 Amp three-prong wall receptacle for your protection against possible shock hazard (Figure 1).

Figure 1

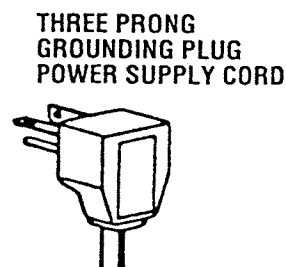
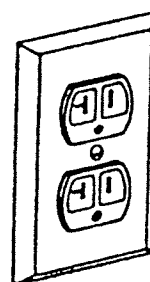

Approved grounding type wall receptacles:  
NEMA NO.5-200R equivalent.

---

## SERVICING AND USEFUL HINTS

**Caution:** Before starting inspection disconnect the welder from the electrical outlet.

Do not bring the torch near the face to check whether the gas or wire are coming out.

Always switch off the welder after use to avoid useless waste of power.

Always shut off the gas after use.

The welder is provided with thermal protection.

Should it activate, wait a few minutes as to let the unit cool down.

When any extension cord is used, its cross section must be the same or greater, never narrower, than the existing power cord on the welder.

Cut the welding wire with tools that do not bend it.

During welding, very small drops of molten metal deposit inside the gas nozzle and therefore it is good to remove the slag in the nozzle.

Every now and then check that the hole of the contact tip has not become too large or closed shut.

Inside the torch hose there is the wire guide sheath, that we recommend cleaning every now and then by blowing a jet of dry and clean air. Never hit the torch strongly against other objects nor let it receive violent blows.

Periodically check electric and gas connections.

## 4.0 USER MANUAL

### NO-GAS CONTINUOUS CORED-WIRE WELDER

#### CONNECTION TO ELECTRIC MAINS

First make sure that switch 8 (Fig .4) is set on **OFF**. Then connect machine electric cable 9 (Fig .4) to an electric outlet.

#### **NOTICE:**

- The yellow/green wire that comes out from the cable is always the ground wire.
- When using an extension cord, use conductors with cross-section areas greater than those of the standard cable. The longer the extension, the larger the cross-section area.

#### **SET UP**

##### **START- UP To insert the coil-carrying reel.**

Unscrew knob 1a (Fig.1). Insert spring and then the reel, making sure that the wire unwinds towards the outside. Put the knob back on and tighten it well. Before inserting the wire drive make sure that no wires overlap on the spool. When this is done, lift wire-pressing spring 3a (Fig.1) to insert the end of the wire. Bring the wire outside. Now the wire can be inserted in the torch sheath for at least 12". Make sure it is in the wire drive roller race marked 0,8. Reclamp the wire-pressing spring. Now the machine is ready to weld. Put switch 7 (Fig.4) on MIN or MAX. Pick up the torch, keeping the sheath stretched. Remove gas guide nozzle 4a (Fig.2), pulling it out. Then unscrew and remove wire-passage contact tip 5a (Fig.2). Make sure this contact tip is for 1 mm. diameter wire. Press torch push-button 6a (Fig.2). After a few seconds the wire should come out from the torch. If it doesn't come out, check to make sure the wire-drive roller isn't slipping on the wire. If it does, adjust the pressure of spring 3a (Fig.1) using screw 2a (Fig.1). Put the wire-passage spout back in, and press down on and fully tighten the gas guide nozzle. Cut off excess wire. Take ground clamp and connect it to the workpiece in a place where there is no paint, plastic or rust. Regulate machine power based on the thickness to be welded. The greater the thickness, the more power is necessary. The best welds are made by holding the torch and moving it as shown in fig. 3. Wire feed speed is automatic, and depends on the MIN or MAX power position. No adjustment is necessary.

**NOTICE :** pilot lamp does not light up when main switch 8 (Fig.4) is in "ON" position, it lights up only when thermal protection cuts off the power. In this phase welding is not possible until the pilot lamp goes off again.

#### **HELPFUL HINTS**

Never use wire other than the type furnished with the machine. Only mild steel can be welded. Clean all rust, paint, etc. off the point where the ground clamp is to be connected. Use the special brush/hammer to clean the bead after welding is terminated. If another pass is going to be made then isn't necessary to removed slag from the weld bead. To make another pass over a fresh bead just clean the start-up point.

**GENERAL MAINTENANCE** Periodically clean dust off internal machine components using a jet of compressed air.

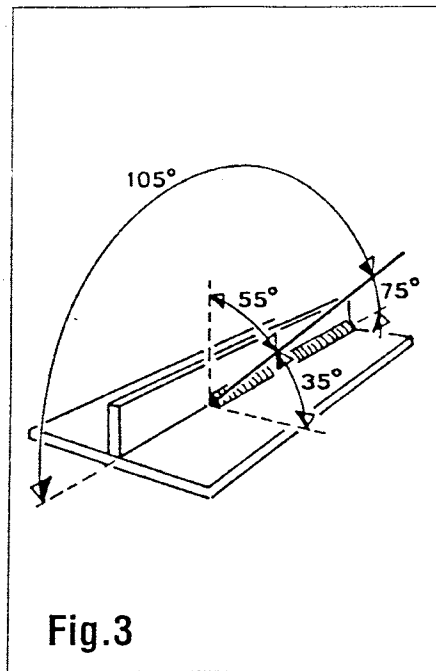
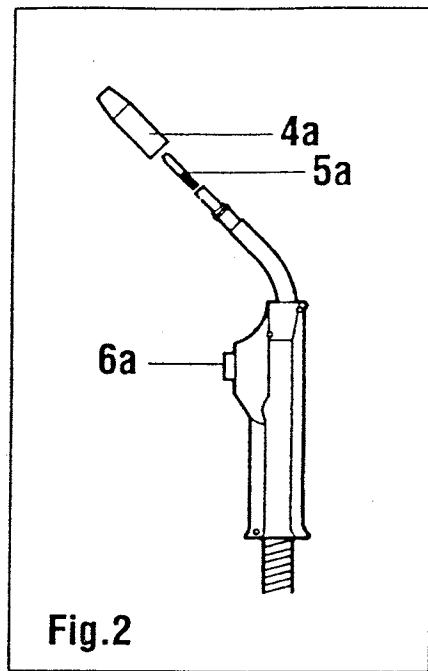
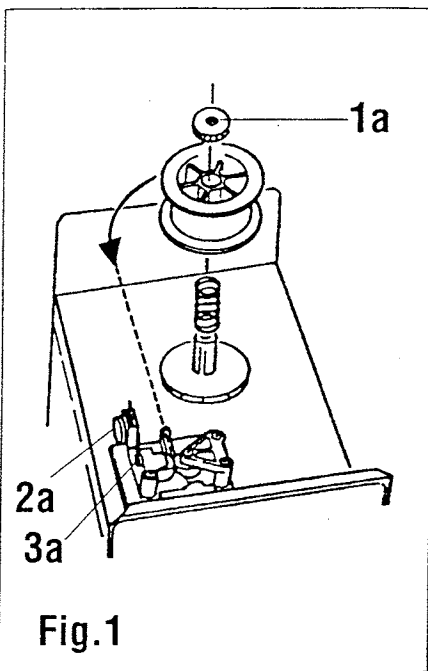

### ELECTRIC DIAGRAM

