

MACHINE SCHEMATIC G8211 REV: B

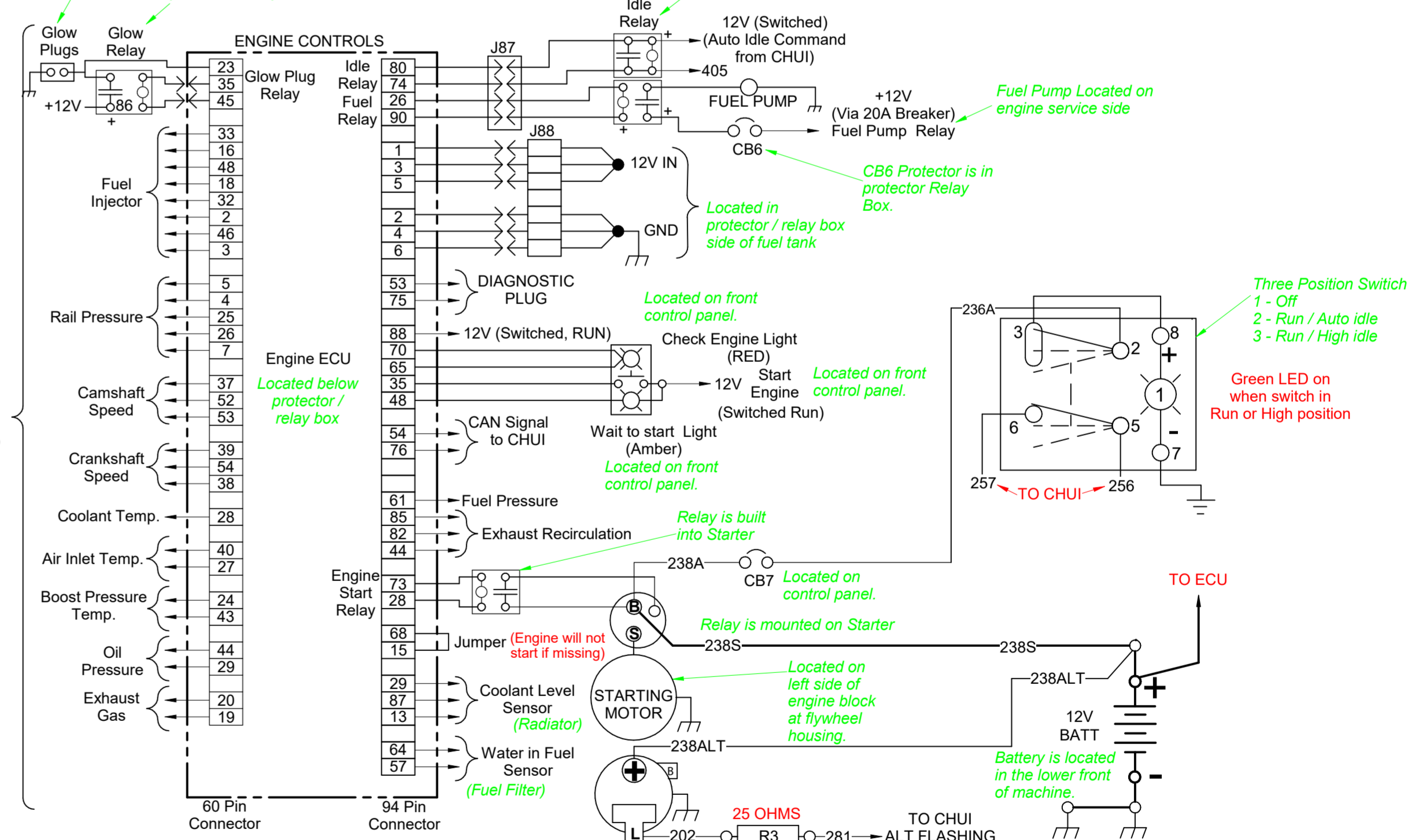
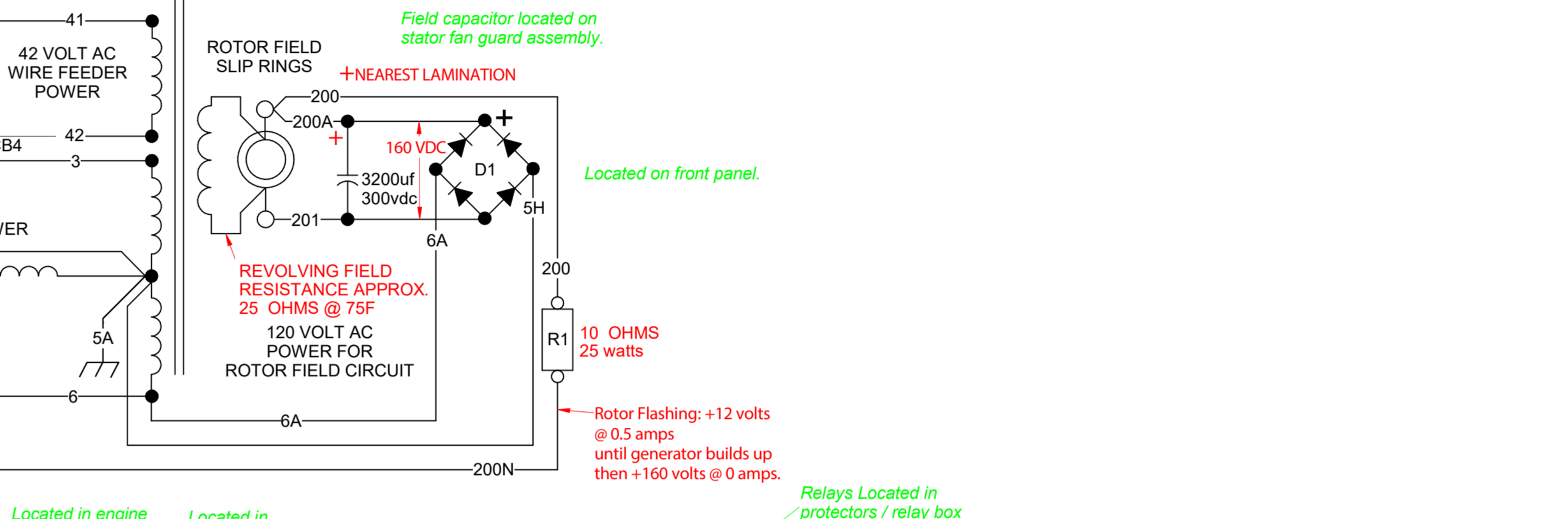
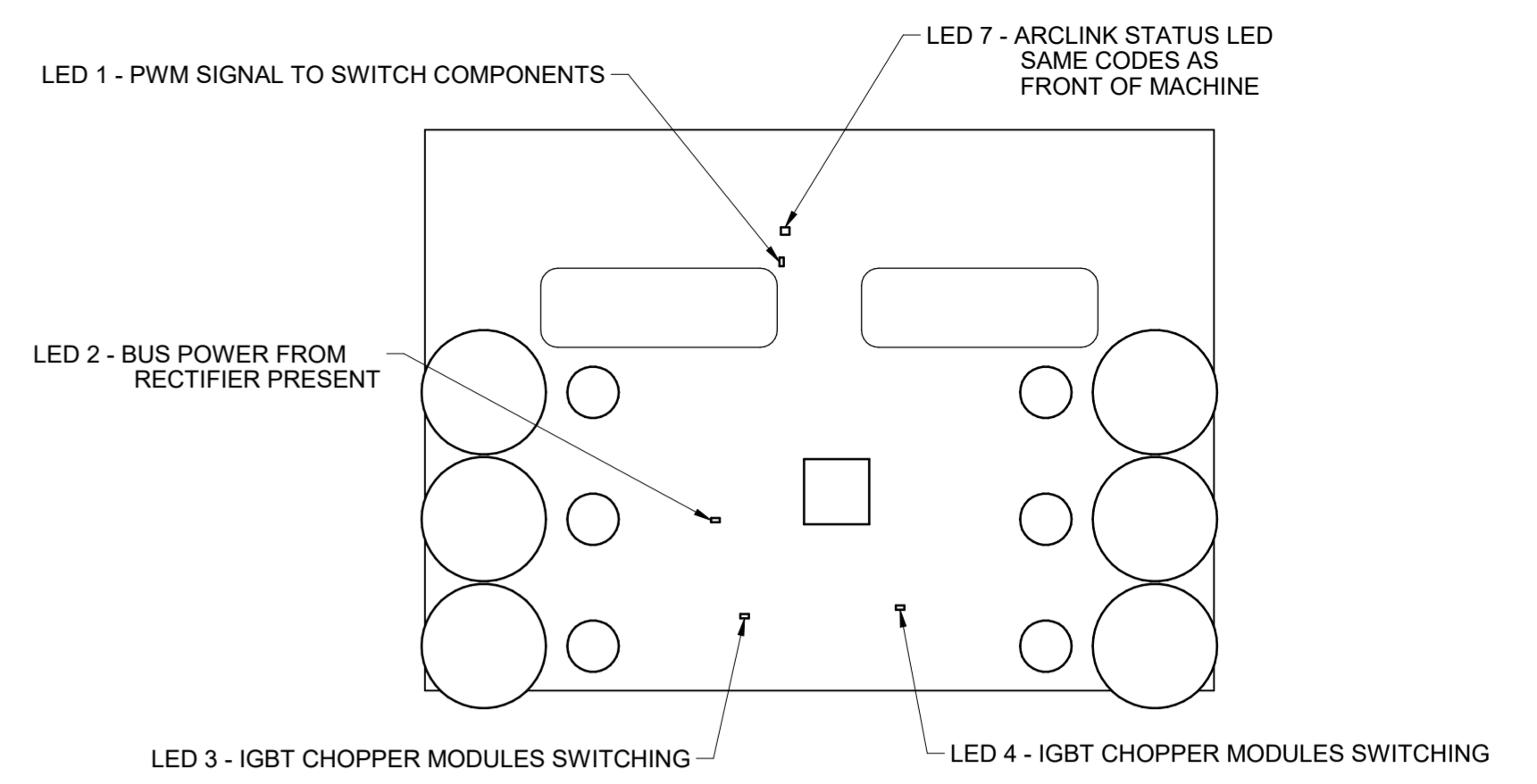
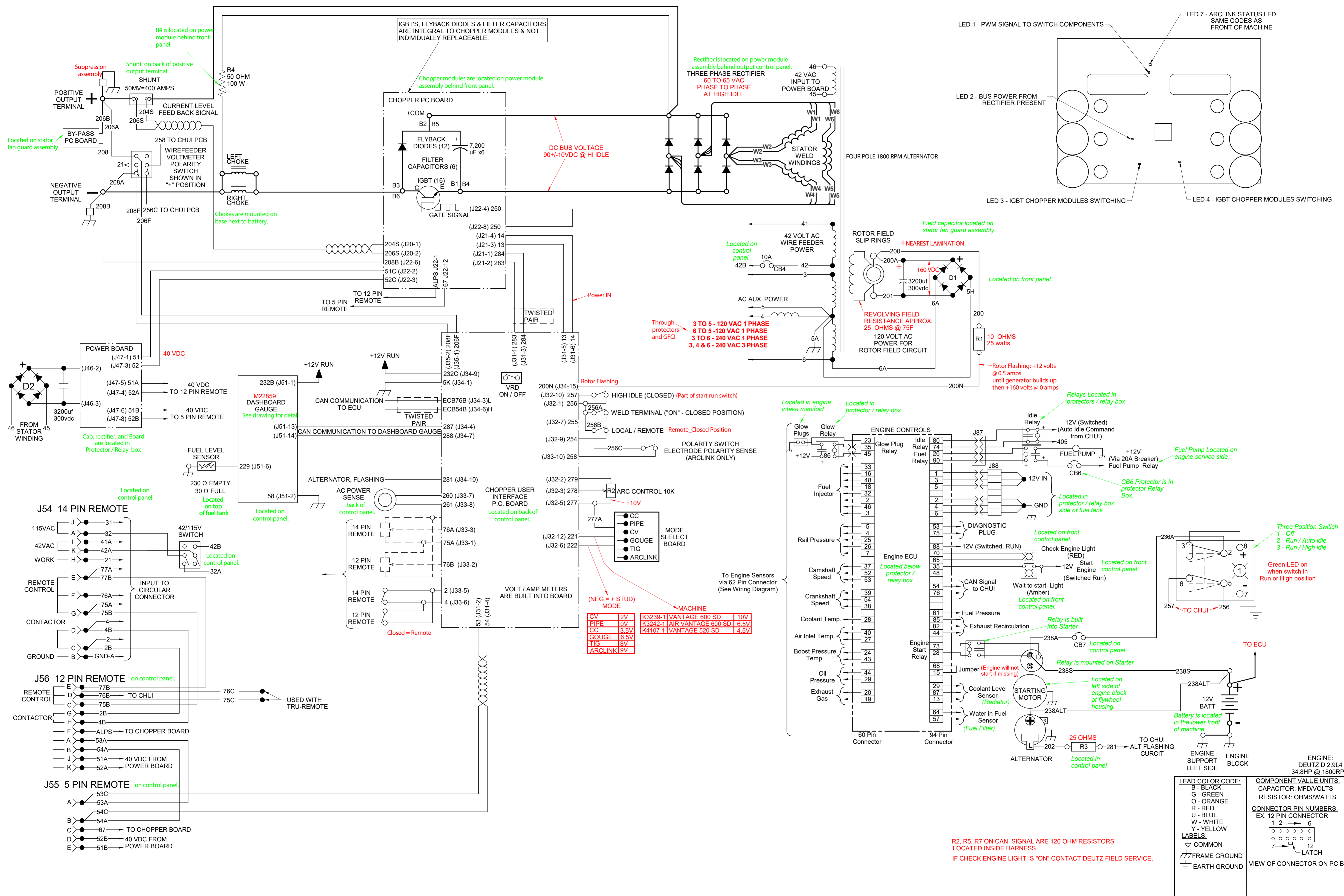

MODE SELECT BOARD

CV	2V	K3239-1 VANTAGE 600 SD	10V
PIPE	0V	K3242-1 AIR VANTAGE 600 SD	6.5V
CC	3.5V	K4107-1 VANTAGE 520 SD	4.5V
GOUGE	6.5V		
TIG	8V		
ARCLINK	9V		

LEAD COLOR CODE:

- B - BLACK
- G - GREEN
- O - ORANGE
- R - RED
- U - BLUE
- W - WHITE
- Y - YELLOW

LABELS:

- ∇ COMMON
- ⊥ FRAME GROUND
- ⊥ EARTH GROUND

COMPONENT VALUE UNITS:

- CAPACITOR: MFD/VOLTS
- RESISTOR: OHMS/WATTS

CONNECTOR PIN NUMBERS:

EX. 12 PIN CONNECTOR

1	2	3	4	5	6
7	8	9	10	11	12

VIEW OF CONNECTOR ON PC BOARD

R2, R5, R7 ON CAN SIGNAL ARE 120 OHM RESISTORS LOCATED INSIDE HARNESS
 IF CHECK ENGINE LIGHT IS "ON" CONTACT DEUTZ FIELD SERVICE.