

Operator's Manual

Prism[®] Central System 4

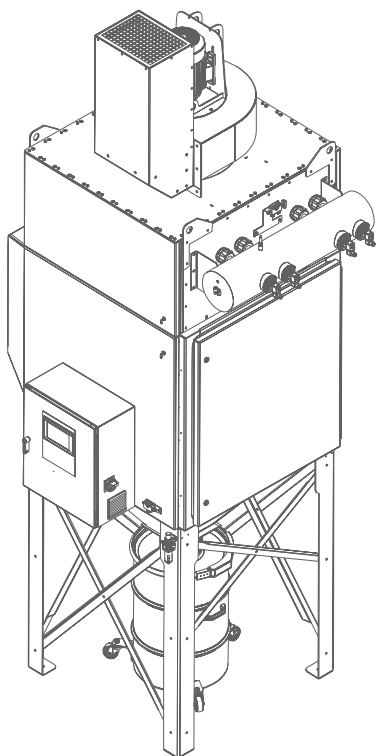

For use with machines having Code Numbers:

UNITS WITH BAFFLE INLET
13305, 13308, 13309, 13311,
13312, 13313, 13314

UNITS WITH PRE-FILTER INLET
13709, 13710, 13711, 13712,
13713, 13714, 13715, 13716



Register your machine:
www.lincolnelectric.com/register

Authorized Service and Distributor Locator:
www.lincolnelectric.com/locator

Save for future reference

Date Purchased

Code: (ex: 10859)

Serial: (ex: U1060512345)

Need Help? Call 1.888.935.3877
to talk to a Service Representative

Hours of Operation:
8:00 AM to 6:00 PM (ET) Mon. thru Fri.

After hours?
Use "Ask the Experts" at lincolnelectric.com
A Lincoln Service Representative will contact you
no later than the following business day.

For Service outside the USA:
Email: globalservice@lincolnelectric.com

THANK YOU FOR SELECTING A QUALITY PRODUCT BY LINCOLN ELECTRIC.

PLEASE EXAMINE CARTON AND EQUIPMENT FOR DAMAGE IMMEDIATELY

When this equipment is shipped, title passes to the purchaser upon receipt by the carrier. Consequently, claims for material damaged in shipment must be made by the purchaser against the transportation company at the time the shipment is received.

SAFETY DEPENDS ON YOU

Lincoln arc welding and cutting equipment is designed and built with safety in mind. However, your overall safety can be increased by proper installation ... and thoughtful operation on your part. **DO NOT INSTALL, OPERATE OR REPAIR THIS EQUIPMENT WITHOUT READING THIS MANUAL AND THE SAFETY PRECAUTIONS CONTAINED THROUGHOUT.** And, most importantly, think before you act and be careful.

WARNING

This statement appears where the information must be followed exactly to avoid serious personal injury or loss of life.

CAUTION

This statement appears where the information must be followed to avoid minor personal injury or damage to this equipment.



KEEP YOUR HEAD OUT OF THE FUMES.

DON'T get too close to the arc. Use corrective lenses if necessary to stay a reasonable distance away from the arc.

READ and obey the Safety Data Sheet (SDS) and the warning label that appears on all containers of welding materials.

USE ENOUGH VENTILATION or exhaust at the arc, or both, to keep the fumes and gases from your breathing zone and the general area.

IN A LARGE ROOM OR OUTDOORS, natural ventilation may be adequate if you keep your head out of the fumes (See below).

USE NATURAL DRAFTS or fans to keep the fumes away from your face.

If you develop unusual symptoms, see your supervisor. Perhaps the welding atmosphere and ventilation system should be checked.

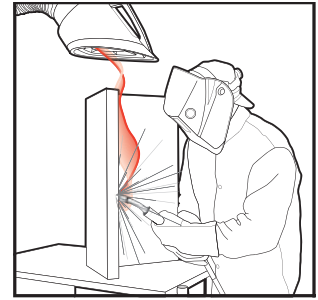

WEAR CORRECT EYE, EAR & BODY PROTECTION

PROTECT your eyes and face with welding helmet properly fitted and with proper grade of filter plate (See ANSI Z49.1).

PROTECT your body from welding spatter and arc flash with protective clothing including woolen clothing, flame-proof apron and gloves, leather leggings, and high boots.

PROTECT others from splatter, flash, and glare with protective screens or barriers.

IN SOME AREAS, protection from noise may be appropriate.

BE SURE protective equipment is in good condition.

Also, wear safety glasses in work area **AT ALL TIMES.**



SPECIAL SITUATIONS

DO NOT WELD OR CUT containers or materials which previously had been in contact with hazardous substances unless they are properly cleaned. This is extremely dangerous.

DO NOT WELD OR CUT painted or plated parts unless special precautions with ventilation have been taken. They can release highly toxic fumes or gases.

Additional precautionary measures

PROTECT compressed gas cylinders from excessive heat, mechanical shocks, and arcs; fasten cylinders so they cannot fall.

BE SURE cylinders are never grounded or part of an electrical circuit.

REMOVE all potential fire hazards from welding area.

ALWAYS HAVE FIRE FIGHTING EQUIPMENT READY FOR IMMEDIATE USE AND KNOW HOW TO USE IT.



SECTION A: WARNINGS



CALIFORNIA PROPOSITION 65 WARNINGS



WARNING: Breathing diesel engine exhaust exposes you to chemicals known to the State of California to cause cancer and birth defects, or other reproductive harm.

- Always start and operate the engine in a well-ventilated area.
- If in an exposed area, vent the exhaust to the outside.
- Do not modify or tamper with the exhaust system.
- Do not idle the engine except as necessary.

For more information go to www.P65warnings.ca.gov/diesel

WARNING: This product, when used for welding or cutting, produces fumes or gases which contain chemicals known to the State of California to cause birth defects and, in some cases, cancer. (California Health & Safety Code § 25249.5 *et seq.*)



WARNING: Cancer and Reproductive Harm
www.P65warnings.ca.gov

ARC WELDING CAN BE HAZARDOUS. PROTECT YOURSELF AND OTHERS FROM POSSIBLE SERIOUS INJURY OR DEATH. KEEP CHILDREN AWAY. PACEMAKER WEARERS SHOULD CONSULT WITH THEIR DOCTOR BEFORE OPERATING.

Read and understand the following safety highlights. For additional safety information, it is strongly recommended that you purchase a copy of "Safety in Welding & Cutting - ANSI Standard Z49.1" from the American Welding Society, P.O. Box 351040, Miami, Florida 33135 or CSA Standard W117.2. A Free copy of "Arc Welding Safety" booklet E205 is available from the Lincoln Electric Company, 22801 St. Clair Avenue, Cleveland, Ohio 44117-1199.

BE SURE THAT ALL INSTALLATION, OPERATION, MAINTENANCE AND REPAIR PROCEDURES ARE PERFORMED ONLY BY QUALIFIED INDIVIDUALS.



FOR ENGINE POWERED EQUIPMENT.

- Turn the engine off before troubleshooting and maintenance work unless the maintenance work requires it to be running.
- Operate engines in open, well-ventilated areas or vent the engine exhaust fumes outdoors.
- Do not add the fuel near an open flame welding arc or when the engine is running. Stop the engine and allow it to cool before refueling to prevent spilled fuel from vaporizing on contact



with hot engine parts and igniting. Do not spill fuel when filling tank. If fuel is spilled, wipe it up and do not start engine until fumes have been eliminated.

- Keep all equipment safety guards, covers and devices in position and in good repair. Keep hands, hair, clothing and tools away from V-belts, gears, fans and all other moving parts when starting, operating or repairing equipment.
- In some cases it may be necessary to remove safety guards to perform required maintenance. Remove guards only when necessary and replace them when the maintenance requiring their removal is complete. Always use the greatest care when working near moving parts.
- Do not put your hands near the engine fan. Do not attempt to override the governor or idler by pushing on the throttle control rods while the engine is running.
- To prevent accidentally starting gasoline engines while turning the engine or welding generator during maintenance work, disconnect the spark plug wires, distributor cap or magneto wire as appropriate.
- To avoid scalding, do not remove the radiator pressure cap when the engine is hot.
- Using a generator indoors CAN KILL YOU IN MINUTES.
- Generator exhaust contains carbon monoxide. This is a poison you cannot see or smell.
- NEVER use inside a home or garage, EVEN IF doors and windows are open.
- Only use OUTSIDE and far away from windows, doors and vents.
- Avoid other generator hazards. READ MANUAL BEFORE USE.



ELECTRIC AND MAGNETIC FIELDS MAY BE DANGEROUS



- Electric current flowing through any conductor causes localized Electric and Magnetic Fields (EMF). Welding current creates EMF fields around welding cables and welding machines
- EMF fields may interfere with some pacemakers, and welders having a pacemaker should consult their physician before welding.
- Exposure to EMF fields in welding may have other health effects which are now not known.
- All welders should use the following procedures in order to minimize exposure to EMF fields from the welding circuit:
 - Route the electrode and work cables together - Secure them with tape when possible.
 - Never coil the electrode lead around your body.
 - Do not place your body between the electrode and work cables. If the electrode cable is on your right side, the work cable should also be on your right side.
 - Connect the work cable to the workpiece as close as possible to the area being welded.
 - Do not work next to welding power source.



ELECTRIC SHOCK CAN KILL.



- 3.a. The electrode and work (or ground) circuits are electrically “hot” when the welder is on. Do not touch these “hot” parts with your bare skin or wet clothing. Wear dry, hole-free gloves to insulate hands.
- 3.b. Insulate yourself from work and ground using dry insulation. Make certain the insulation is large enough to cover your full area of physical contact with work and ground.

In addition to the normal safety precautions, if welding must be performed under electrically hazardous conditions (in damp locations or while wearing wet clothing; on metal structures such as floors, gratings or scaffolds; when in cramped positions such as sitting, kneeling or lying, if there is a high risk of unavoidable or accidental contact with the workpiece or ground) use the following equipment:

- Semiautomatic DC Constant Voltage (Wire) Welder.
 - DC Manual (Stick) Welder.
 - AC Welder with Reduced Voltage Control.
- 3.c. In semiautomatic or automatic wire welding, the electrode, electrode reel, welding head, nozzle or semiautomatic welding gun are also electrically “hot”.
 - 3.d. Always be sure the work cable makes a good electrical connection with the metal being welded. The connection should be as close as possible to the area being welded.
 - 3.e. Ground the work or metal to be welded to a good electrical (earth) ground.
 - 3.f. Maintain the electrode holder, work clamp, welding cable and welding machine in good, safe operating condition. Replace damaged insulation.
 - 3.g. Never dip the electrode in water for cooling.
 - 3.h. Never simultaneously touch electrically “hot” parts of electrode holders connected to two welders because voltage between the two can be the total of the open circuit voltage of both welders.
 - 3.i. When working above floor level, use a safety belt to protect yourself from a fall should you get a shock.
 - 3.j. Also see Items 6.c. and 8.



ARC RAYS CAN BURN.



- 4.a. Use a shield with the proper filter and cover plates to protect your eyes from sparks and the rays of the arc when welding or observing open arc welding. Headshield and filter lens should conform to ANSI Z87.1 standards.
- 4.b. Use suitable clothing made from durable flame-resistant material to protect your skin and that of your helpers from the arc rays.
- 4.c. Protect other nearby personnel with suitable, non-flammable screening and/or warn them not to watch the arc nor expose themselves to the arc rays or to hot spatter or metal.



FUMES AND GASES CAN BE DANGEROUS.



- 5.a. Welding may produce fumes and gases hazardous to health. Avoid breathing these fumes and gases. When welding, keep your head out of the fume. Use enough ventilation and/or exhaust at the arc to keep fumes and gases away from the breathing zone. **When welding hardfacing (see instructions on container or SDS) or on lead or cadmium plated steel and other metals or coatings which produce highly toxic fumes, keep exposure as low as possible and within applicable OSHA PEL and ACGIH TLV limits using local exhaust or mechanical ventilation unless exposure assessments indicate otherwise. In confined spaces or in some circumstances, outdoors, a respirator may also be required. Additional precautions are also required when welding on galvanized steel.**
- 5.b. The operation of welding fume control equipment is affected by various factors including proper use and positioning of the equipment, maintenance of the equipment and the specific welding procedure and application involved. Worker exposure level should be checked upon installation and periodically thereafter to be certain it is within applicable OSHA PEL and ACGIH TLV limits.
- 5.c. Do not weld in locations near chlorinated hydrocarbon vapors coming from degreasing, cleaning or spraying operations. The heat and rays of the arc can react with solvent vapors to form phosgene, a highly toxic gas, and other irritating products.
- 5.d. Shielding gases used for arc welding can displace air and cause injury or death. Always use enough ventilation, especially in confined areas, to insure breathing air is safe.
- 5.e. Read and understand the manufacturer’s instructions for this equipment and the consumables to be used, including the Safety Data Sheet (SDS) and follow your employer’s safety practices. SDS forms are available from your welding distributor or from the manufacturer.
- 5.f. Also see item 1.b.



WELDING AND CUTTING SPARKS CAN CAUSE FIRE OR EXPLOSION.



- 6.a. Remove fire hazards from the welding area. If this is not possible, cover them to prevent the welding sparks from starting a fire. Remember that welding sparks and hot materials from welding can easily go through small cracks and openings to adjacent areas. Avoid welding near hydraulic lines. Have a fire extinguisher readily available.
- 6.b. Where compressed gases are to be used at the job site, special precautions should be used to prevent hazardous situations. Refer to "Safety in Welding and Cutting" (ANSI Standard Z49.1) and the operating information for the equipment being used.
- 6.c. When not welding, make certain no part of the electrode circuit is touching the work or ground. Accidental contact can cause overheating and create a fire hazard.
- 6.d. Do not heat, cut or weld tanks, drums or containers until the proper steps have been taken to insure that such procedures will not cause flammable or toxic vapors from substances inside. They can cause an explosion even though they have been "cleaned". For information, purchase "Recommended Safe Practices for the Preparation for Welding and Cutting of Containers and Piping That Have Held Hazardous Substances", AWS F4.1 from the American Welding Society (see address above).
- 6.e. Vent hollow castings or containers before heating, cutting or welding. They may explode.
- 6.f. Sparks and spatter are thrown from the welding arc. Wear oil free protective garments such as leather gloves, heavy shirt, cuffless trousers, high shoes and a cap over your hair. Wear ear plugs when welding out of position or in confined places. Always wear safety glasses with side shields when in a welding area.
- 6.g. Connect the work cable to the work as close to the welding area as practical. Work cables connected to the building framework or other locations away from the welding area increase the possibility of the welding current passing through lifting chains, crane cables or other alternate circuits. This can create fire hazards or overheat lifting chains or cables until they fail.
- 6.h. Also see item 1.c.
- 6.i. Read and follow NFPA 51B "Standard for Fire Prevention During Welding, Cutting and Other Hot Work", available from NFPA, 1 Batterymarch Park, PO box 9101, Quincy, MA 022690-9101.
- 6.j. Do not use a welding power source for pipe thawing.



CYLINDER MAY EXPLODE IF DAMAGED.

- 7.a. Use only compressed gas cylinders containing the correct shielding gas for the process used and properly operating regulators designed for the gas and pressure used. All hoses, fittings, etc. should be suitable for the application and maintained in good condition. 
- 7.b. Always keep cylinders in an upright position securely chained to an undercarriage or fixed support.
- 7.c. Cylinders should be located:
 - Away from areas where they may be struck or subjected to physical damage.
 - A safe distance from arc welding or cutting operations and any other source of heat, sparks, or flame.
- 7.d. Never allow the electrode, electrode holder or any other electrically "hot" parts to touch a cylinder.
- 7.e. Keep your head and face away from the cylinder valve outlet when opening the cylinder valve.
- 7.f. Valve protection caps should always be in place and hand tight except when the cylinder is in use or connected for use.
- 7.g. Read and follow the instructions on compressed gas cylinders, associated equipment, and CGA publication P-1, "Precautions for Safe Handling of Compressed Gases in Cylinders," available from the Compressed Gas Association, 14501 George Carter Way Chantilly, VA 20151.



FOR ELECTRICALLY POWERED EQUIPMENT.



- 8.a. Turn off input power using the disconnect switch at the fuse box before working on the equipment.
- 8.b. Install equipment in accordance with the U.S. National Electrical Code, all local codes and the manufacturer's recommendations.
- 8.c. Ground the equipment in accordance with the U.S. National Electrical Code and the manufacturer's recommendations.

Refer to
<http://www.lincolnelectric.com/safety>
for additional safety information.

As a rule of thumb, for many mild steel electrode, if the air is visibly clear and you are comfortable, then the ventilation is generally adequate for your work. The most accurate way to determine if the worker exposure does not exceed the applicable exposure limit for compounds in the fumes and gases is to have an industrial hygienist take and analyze a sample of the air you are breathing. This is particularly important if you are welding with stainless, hardfacing or Special Ventilation products. All Lincoln MSDS have a maximum fume guideline number. If exposure to total fume is kept below that number, exposure to all fume from the electrode (not coatings or plating on the work) will be below the TLV.

There are steps that you can take to identify hazardous substances in your welding environment. Read the product label and material safety data sheet for the electrode posted in the work place or in the electrode or flux container to see what fumes can be reasonably expected from use of the product and to determine if special ventilation is needed. Secondly, know what the base metal is and determine if there is any paint, plating, or coating that could expose you to toxic fumes and/or gases. Remove it from the metal being welded, if possible. If you start to feel uncomfortable, dizzy or nauseous, there is a possibility that you are being overexposed to fumes and gases, or suffering from oxygen deficiency. Stop welding and get some fresh air immediately. Notify your supervisor and co-workers so the situation can be corrected and other workers can avoid the hazard. Be sure you are following these safe practices, the consumable labeling and MSDS to improve the ventilation in your area. Do not continue welding until the situation has been corrected.

NOTE: The MSDS for all Lincoln consumables is available on Lincoln's website: www.lincolnelectric.com

Before we turn to the methods available to control welding fume exposure, you should understand a few basic terms:

Natural Ventilation is the movement of air through the workplace caused by natural forces. Outside, this is usually the wind. Inside, this may be the flow of air through open windows and doors.

Mechanical Ventilation is the movement of air through the workplace caused by an electrical device such as a portable fan or permanently mounted fan in the ceiling or wall.

Source Extraction (Local Exhaust) is a mechanical device used to capture welding fume at or near the arc and filter contaminants out of the air.

The ventilation or exhaust needed for your application depends upon many factors such as:

- Workspace volume
- Workspace configuration
- Number of welders
- Welding process and current
- Consumables used (mild steel, hardfacing, stainless, etc.)
- Allowable levels (TLV, PEL, etc.)
- Material welded (including paint or plating)
- Natural airflow

Your work area has adequate ventilation when there is enough ventilation and/or exhaust to control worker exposure to hazardous materials in the welding fumes and gases so the applicable limits for those materials is not exceeded. See chart of TLV and PEL for Typical Electrode Ingredients, the OSHA PEL

(Permissible Exposure Limit), and the recommended guideline, the ACGIH TLV (Threshold Limit Value), for many compounds found in welding fume.

Ventilation

There are many methods which can be selected by the user to provide adequate ventilation for the specific application. The following section provides general information which may be helpful in evaluating what type of ventilation equipment may be suitable for your application. When ventilation equipment is installed, you should confirm worker exposure is controlled within applicable OSHA PEL and/or ACGIH TLV. According to OSHA regulations, when welding and cutting (mild steels), natural ventilation is usually considered sufficient to meet requirements, provided that:

1. The room or welding area contains at least 10,000 cubic feet (about 22' x 22' x 22') for each welder.
2. The ceiling height is not less than 16 feet.
3. Cross ventilation is not blocked by partitions, equipment, or other structural barriers.
4. Welding is not done in a confined space.

Spaces that do not meet these requirements should be equipped with mechanical ventilating equipment that exhausts at least 2000 CFM of air for each welder, except where local exhaust hoods or booths, or air-line respirators are used.

Important Safety Note:

When welding with electrodes which require special ventilation such as stainless or hardfacing (see instructions on container or MSDS) or on lead or cadmium plated steel and other metals or coatings which produce hazardous fumes, keep exposure as low as possible and below exposure limit values (PEL and TLV) for materials in the fume using local exhaust or mechanical ventilation. In coned spaces or in some circumstances, for example outdoors, a respirator may be required if exposure cannot be controlled to the PEL or TLV. (See MSDS and chart of TLV and PEL for Typical Electrode Ingredients.) Additional precautions are also required when welding on galvanized steel.

BIBLIOGRAPHY AND SUGGESTED READING

ANSI Z87.1, Practice for Occupational and Educational Eye and Face Protection, American National Standards Institute, 11 West 42nd Street, New York, NY 10036.

Arc Welding and Your Health: A Handbook of Health Information for Welding. Published by The American Industrial Hygiene Association, 2700 Prosperity Avenue, Suite 250, Fairfax, VA 22031-4319.

NFPA Standard 51B, Cutting and Welding Processes, National Fire Protection Association, 1 Batterymarch Park, P.O. Box 9146, Quincy, MA 02269-9959.

OSHA General Industry Standard 29 CFR 1910 Subpart Q. OSHA Hazard Communication Standard 29 CFR 1910.1200. Available from the Occupational Safety and Health Administration at <http://www.osha.org> or contact your local OSHA office.

The following publications are published by The American Welding Society, P.O. Box 351040, Miami, Florida 33135. AWS publications may be purchased from the American Welding Society at <http://www.aws.org> or by contacting the AWS at 800-443-9353.

ANSI, Standard Z49.1, Safety in Welding, Cutting and Allied Processes. Z49.1 is now available for download at no charge at <http://www.lincolnelectric.com/community/safety/> or at the AWS website <http://www.aws.org>.

AWS F1.1, Method for Sampling Airborne Particulates Generated by Welding and Allied Processes.

AWS F1.2, Laboratory Method for Measuring Fume Generation Rates and Total Fume Emission of Welding and Allied Processes.

AWS F1.3, Evaluating Contaminants in the Welding Environment: A Strategic Sampling Guide.

AWS F1.5, Methods for Sampling and Analyzing Gases from Welding and Allied Processes.

AWS F3.2, Ventilation Guide for Welding Fume Control

AWS F4.1, Recommended Safe Practices for the Preparation for Welding and Cutting of Containers and Piping That Have Held Hazardous Substances.

AWS SHF, Safety and Health Facts Sheets. Available free of charge from the AWS website at <http://www.aws.org>.

LISTED BELOW ARE SOME TYPICAL INGREDIENTS IN WELDING ELECTRODES AND THEIR TLV (ACGIH) GUIDELINES AND PEL (OSHA) EXPOSURE LIMITS

INGREDIENTS	CAS No.	TLV mg/m ³	PEL mg/m ³
Aluminum and/or aluminum alloys (as Al)*****	7429-90-5	1.0	15
Aluminum oxide and/or Bauxite*****	1344-28-1	1.0	5**
Barium compounds (as Ba)*****	513-77-9	0.5	0.5
Chromium and chromium alloys or compounds (as Cr)*****	7440-47-3	0.5(b)	0.5(b)
Hexavalent Chromium (Cr VI)	18540-29-9	0.05(b)	.005(b)
Copper Fume	7440-50-8	0.2	0.1
Cobalt Compounds	7440-48-4	0.02	0.1
Fluorides (as F)	7789-75-5	2.5	2.5
Iron	7439-89-6	10*	10*
Limestone and/or calcium carbonate	1317-65-3	10*	15
Lithium compounds (as Li)	554-13-2	15	10*
Magnesite	1309-48-4	10	15
Magnesium and/or magnesium alloys and compounds (as Mg)	7439-95-4	10*	10*
Manganese and/or manganese alloys and compounds (as Mn)*****	7439-96-5	0.02	5.0(c)
Mineral silicates	1332-58-7	5**	5**
Molybdenum alloys (as Mo)	7439-98-7	10	10
Nickel*****	7440-02-0	0.1	1
Silicates and other binders	1344-09-8	10*	10*
Silicon and/or silicon alloys and compounds (as Si)	7440-21-3	10*	10*
Strontium compounds (as Sr)	1633-05-2	10*	10*
Zirconium alloys and compounds (as Zr)	12004-83-0	5	5

Supplemental Information:

(*) Not listed. Nuisance value maximum is 10 milligrams per cubic meter. PEL value for iron oxide is 10 milligrams per cubic meter. TLV value for iron oxide is 5 milligrams per cubic meter.

(**) As respirable dust.

(****) Subject to the reporting requirements of Sections 311, 312, and 313 of the Emergency Planning and Community Right-to-Know Act of 1986 and of 40CFR 370 and 372.

(b) The PEL for chromium (VI) is .005 milligrams per cubic meter as an 8 hour time weighted average. The TLV for water-soluble chromium (VI) is 0.05 milligrams per cubic meter. The TLV for insoluble chromium (VI) is 0.01 milligrams per cubic meter.

(c) Values are for manganese fume. STEL (Short Term Exposure Limit) is 3.0 milligrams per cubic meter. OSHA PEL is a ceiling value.

(****) The TLV for soluble barium compounds is 0.5 mg/m³.

TLV and PEL values are as of October 2013. Always check Safety Data Sheet (SDS) with product or on the Lincoln Electric website at <http://www.lincolnelectric.com>

INSTALLATION	SECTION A
TECHNICAL SPECIFICATIONS	A-1
INLET OPTIONS	A-2
GENERAL DESCRIPTION	A-3
THE INTENDED PURPOSE	A-3
TRANSPORT AND ERECTION	A-3
SELECT SUITABLE LOCATION	A-3
ENVIRONMENTAL AREA	A-3
INSTALLATION OF PRISM® 4	A-4
ELECTRICAL CONNECTIONS	A-8
RELOCATE CONTROL PANEL TO RIGHT SIDE	A-8
OPERATION	SECTION B
USERS	B-1
INTENDED USE	B-1
MODIFICATIONS	B-1
RESTRICTIONS	B-1
CONTROL	B-2
HMI CONTROLLER AND NAVIGATION	B-3
SOFTWARE FUNCTIONS (FAN, FILTER CLEANING, ALARMS)	B-12
FUNCTIONS	B-12
OPERATION	B-12
SMARTWIRE DEVICE LEARNING	B-13
STARTUP	B-13
SET POINTS	B-13
ACCESSORIES	SECTION C
REPLACEMENT FILTER OPTIONS	C-1
PRISM® THERMAL SUPPRESSION	C-2
SYSTEM OVERVIEW	C-2
SYSTEM COMPONENTS	C-2
INSTALLATION	C-3
ACTIVATION	C-3
OPERATION AND DIAGNOSTICS	C-4
DISCHARGE AND RECOVERY	C-4
ALARM IDENTIFICATION AND TROUBLESHOOTING	C-5
ALARM IDENTIFICATION AND RESOLUTION	C-6
MAINTENANCE	SECTION D
MALFUNCTIONS AND EMERGENCIES EFFECTING THE FILTER UNIT	D-1
ESCAPE OF NOXIOUS SUBSTANCES OR RADIATION	D-1
PERIODIC MAINTENANCE	D-2
MAINTENANCE SCHEDULE	D-2
REPLACING FILTER CARTRIDGES OR EMPTYING DUSTBINS	D-3
REPLACING FILTER CARTRIDGES	D-4
REPLACING PRE-FILTER	D-5
TROUBLESHOOTING	SECTION E
DIAGRAMS	SECTION F
PARTS LIST	PARTS.LINCOLNELECTRIC.COM
CONTENT/DETAILS MAY BE CHANGED OR UPDATED WITHOUT NOTICE. FOR MOST CURRENT INSTRUCTION MANUALS, GO TO PARTS.LINCOLNELECTRIC.COM.	

TECHNICAL SPECIFICATIONS

GENERAL	
TYPE OF CLEANING	Pulse jet
DUTY CYCLE	100%
COMPRESSED AIR PRESSURE AND QUALITY	72 - 87 psi (5 - 6 bar) clean, dry and oil free

PRISM® 4 AIR CONSUMPTION			
6 BAR / 87 PSI Recommended		Prism 4 (1 valve per pulse)	
On Time (msec)		150	250
Compressed Air Consumption (cfm)			
Off Time (Sec)	5	39.0	51.6
	10	19.5	25.8
	15	13.0	17.2
	20	9.8	12.9
	25	7.8	10.3
	30	6.5	8.6
	35	5.6	7.4
	40	4.9	6.5
	45	4.3	5.7
	50	3.9	5.2
	55	3.5	4.7
	60	3.3	4.3

1. Compressed air to be clean, dry, oil free, and have a dew point of -40°F (-40°C)
2. Boldface values are factory defaults
3. Off Time Default (pause time between pulses): 15 sec
4. On Time Default: 250 msec
5. Compressed air pressure of 5 bar (72 psi) reduces consumption by 20% (approx.)
6. Filter cleaning functions detailed in section B

FILTER CLASS (ACCORDING TO ASHRAE 52.2)	
KP4519-1	MERV 11
KP4519-2	MERV 16 NANO
KP4519-3	MERV 16 PTFE
KP4519-4	MERV 11 OIL RESISTANT
KP4519-5	MERV 16 NANO OIL RESISTANT

AMBIENT CONDITIONS	
MINIMUM TEMPERATURE	-4°F (-20°C) 37°F (3°C) *Normal Operation with Thermal Suppression
MAXIMUM TEMPERATURE	113°F (45°C)
MAXIMUM RELATIVE HUMIDITY	75%

PRISM® 4: AD1326-17, AD1326-20, AD1326-27, AD1326-28, AD1326-29, AD1326-30	
INPUT VOLTAGE NOMINAL +/- 10%	380-480V/3~/50-60Hz
MAXIMUM CURRENT	7.5 A
MOTOR POWER	5HP
INSULATION CLASS FAN MOTOR	F
PROTECTION CLASS FAN MOTOR	IP54
DIMENSIONS	See Section F
SUPPLY FUSE	Class J OR CC 30A/600V
ALARM LEVEL	2000Pa (factory default)"

PRISM® 4: AD1326-18, AD1326-19, AD1326-21, AD1326-22, AD1326-31, AD1326-32, AD1326-33, AD1326-34, AD1326-35	
INPUT VOLTAGE NOMINAL +/- 10%	380-480V/3~/50-60Hz
MAXIMUM CURRENT	14.5 A
MOTOR POWER	10 HP
INSULATION CLASS FAN MOTOR	F
PROTECTION CLASS FAN MOTOR	IP54
DIMENSIONS	See Section F
SUPPLY FUSE	Class J OR CC 30A/600V
ALARM LEVEL	2000Pa (factory default)

INLET OPTIONS

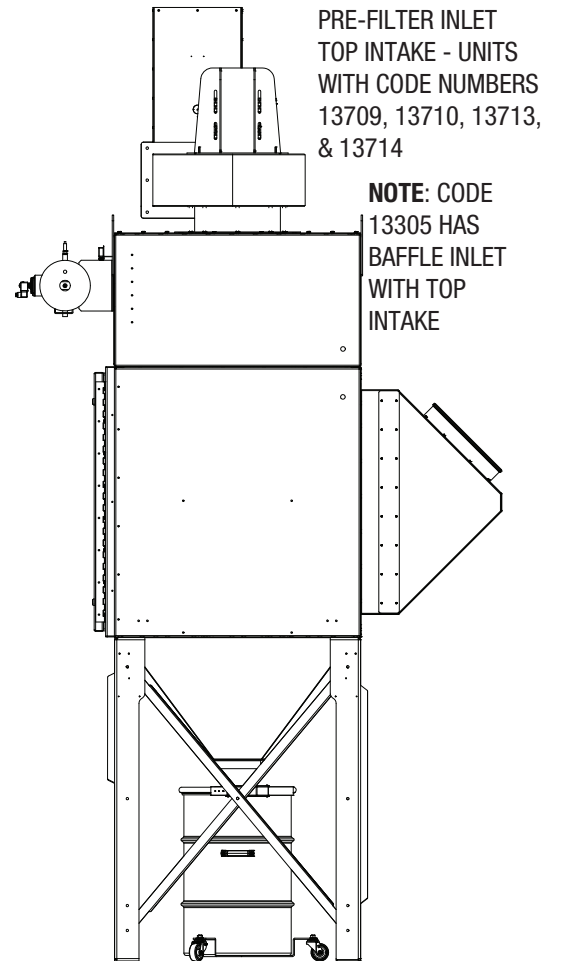
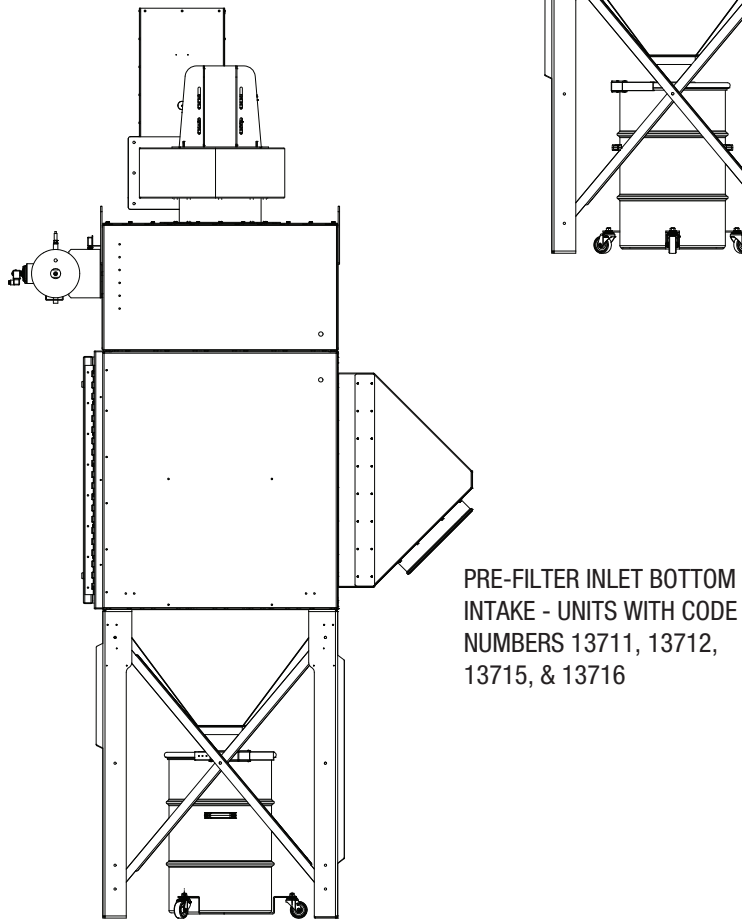
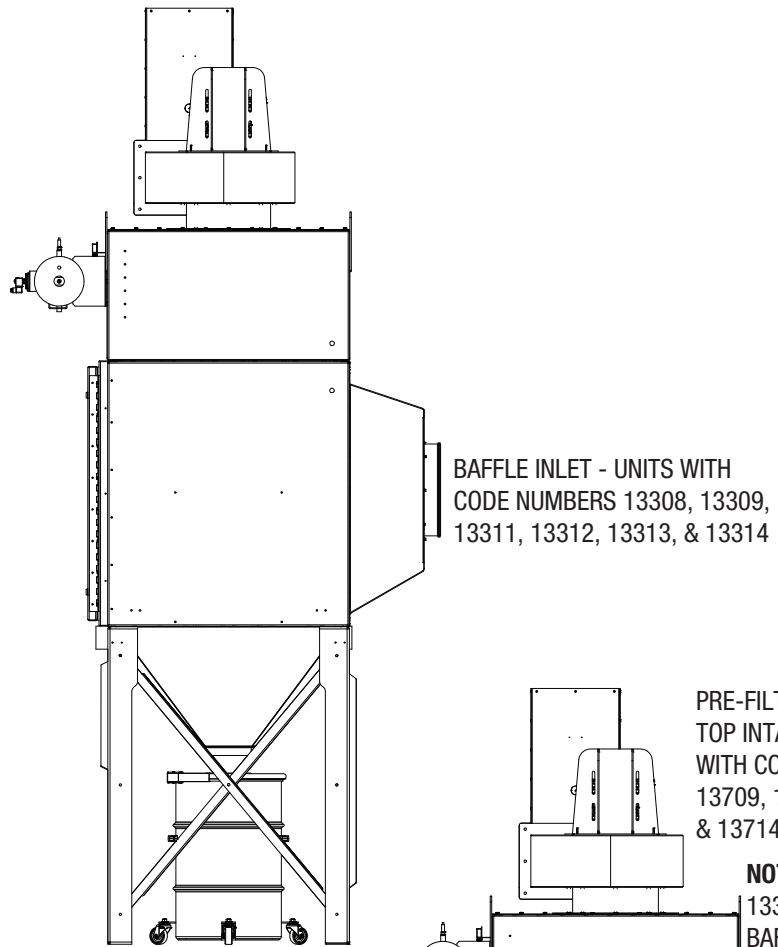

INSTALLATION

GENERAL DESCRIPTION

Prism® 4 is a reduced-footprint fan/filtration unit combination designed with robotic welding and plasma cutting systems in mind. The 4-filter configurations can provide extraction capacity for just about any automated system equipped with a hood.

Pre-assembly and Lincoln Smart Connect™ technology allow for easy and quick installation.

The fan pulls the air with particulate through the filters. When the pressure over the filter reaches a preset point, the internal self-cleaning mechanism begins to clean the filter cartridges by means of compressed air shots, resulting in the particulate dropping into a dustbin at the bottom of the unit.

THE INTENDED PURPOSE

Extraction of fumes that are released in the course of using welding equipment for cutting and joining non-alloy and alloy steels, including highalloy chromium/nickel steels with a nickel and chromium content of $\geq 30\%$

TRANSPORT AND ERECTION

ATTENTION

Instruct all persons whose presence is not required to stay out of the hazard area



Do not stand under or next to the load when it is being lifted up or set down

Transport the unit or erection components on the pallets provided, and secure them against falling over or slipping.

Transport them with a suitable pallet truck or forklift truck

Taller units should be built up on site

Filter units must be secured to the foundations

The foundations must have adequate load-bearing strength and be free of vibration

ATTENTION

- The installer is responsible for following federal, state and local safety codes and regulations.
- Before drilling, verify locations of existing gas, water or electrical conduits.



WARNING

Excluded Uses!

- Welding fumes containing oil
- Aluminum grinding dust
- Burning or incandescent materials
- Cigarettes
- Aggressive media
- Water and moisture
- Explosive gases and/or dust mixtures
- Dusts with toxic characteristics other than welding fumes
- The installation of this product is exclusively reserved to authorized, well-trained and qualified professional electrical and mechanical contractors. A goal of the Smartwire is quick installation, possibly without any LE involvement.
- Inspect the product and check it for damage. Verify the functioning of the safety features.
- Electrical connection to be executed in accordance with local requirements. Ensure compliance with the EMC regulatory arrangements.
- Check the working environment. Do not allow unauthorized persons to enter the working environment.
- Protect the product against water and humidity.
- Use common sense. Stay alert and keep your attention to your work. Do not use the product when you are under the influence of drugs, alcohol or medicine.
- Ensure the workspace is well-illuminated.
- Make sure the room is always sufficiently ventilated; this applies especially to confined spaces.
- Never install the product in front of entrances and exits which must be used for emergency services.
- Make sure that the workshop, in the vicinity of the product, contains sufficient approved fire extinguishers.
- Make sure the wall, ceiling or support system are strong enough to carry the product.
- Air containing particles such as chromium, nickel, beryllium, cadmium, lead etc., which is a health hazard, should never be recycled. This air must always be brought outside the working area.

SELECT SUITABLE LOCATION

- Do not place equipment near radiant heat sources.
- Do not place in a confined space. Allow a minimum of 3 feet of clearance around machine at all times for maintenance requirements.

ENVIRONMENTAL AREA

Keep the machine inside and dry at all times. Do not place on wet ground or in puddles. Never place liquids on top of the machine.

INSTALLATION OF PRISM® 4

TOOLS NEEDED

- 5/16" Nutdriver
- 3/8" Nutdriver
- 1/2" Nutdriver
- 9/16" Nutdriver
- 9/16" Box Wrench
- Appropriate Hoist and Rigging
- Liquid Sealant
- Strip Foam Gasket
- Miscellaneous Hand Tools
- Ladder/Lift
- Drill
- 1/4" Drill Bit

Step 1 – Unpack The Leg Base W/ Hopper

Unpack leg base w/ hopper assembly and place it in desired location.

FIGURE A.1

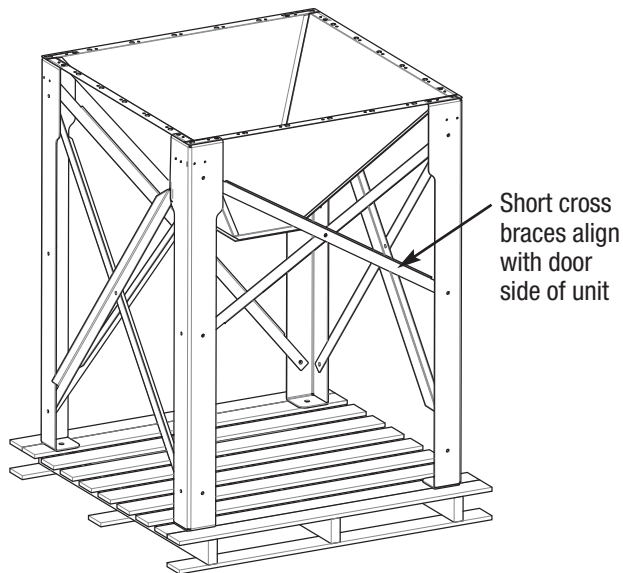

Step 2 – Lift Main Body Into Vertical Position

FIGURE A.2

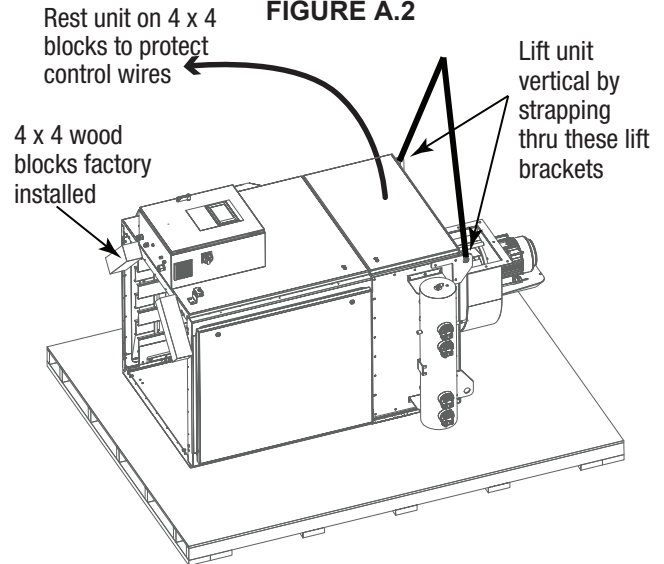
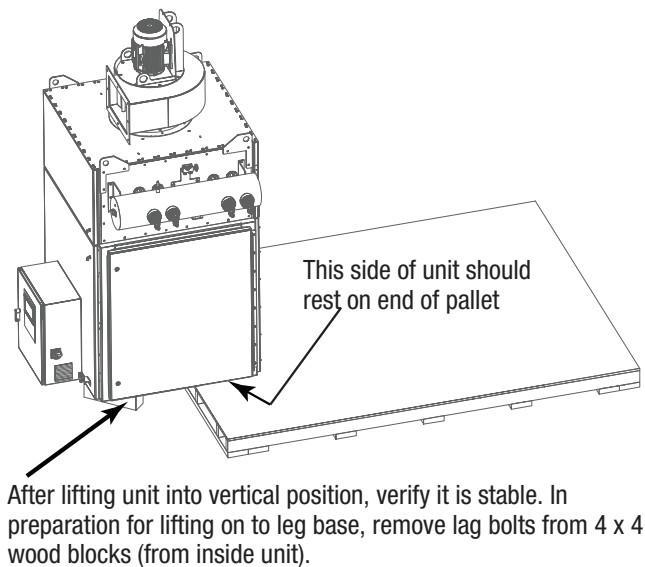

FIGURE A.3



Step 3 – Install Main Module On Leg Base/Hopper

FIGURE A.4

Place leg base hopper assembly in desired position, then apply strip foam gasket (supplied in hopper carton) completely around top of hopper flange as shown. Apply strip foam gasket on both sides of bolt holes and overlap in corners, then place a bead of liquid sealant between foam strips.

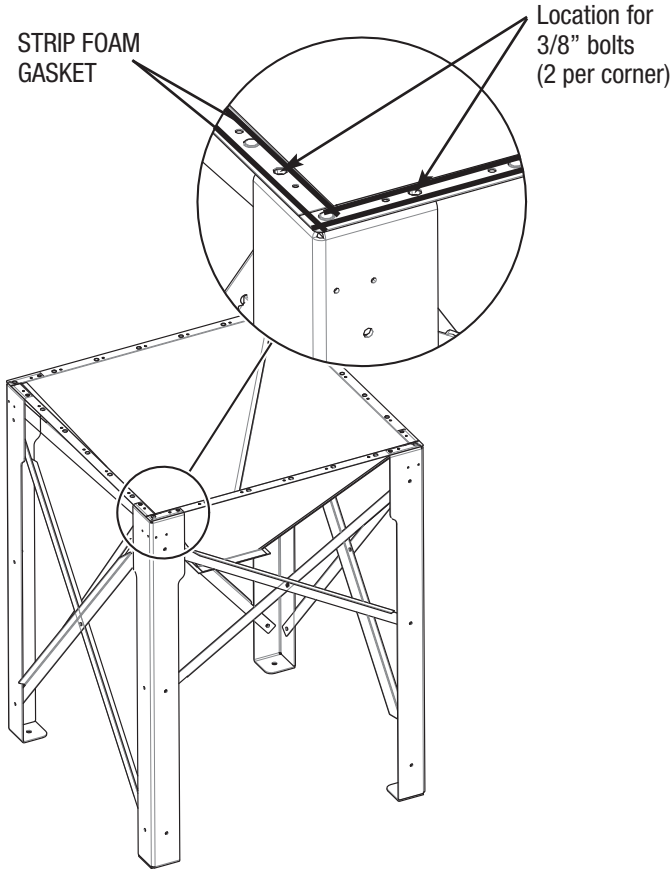

Place the leg base/hopper directly on a secure, level surface. The unit may topple over if this procedure is not followed.

Lift main module on top of leg base.

FIGURE A.5

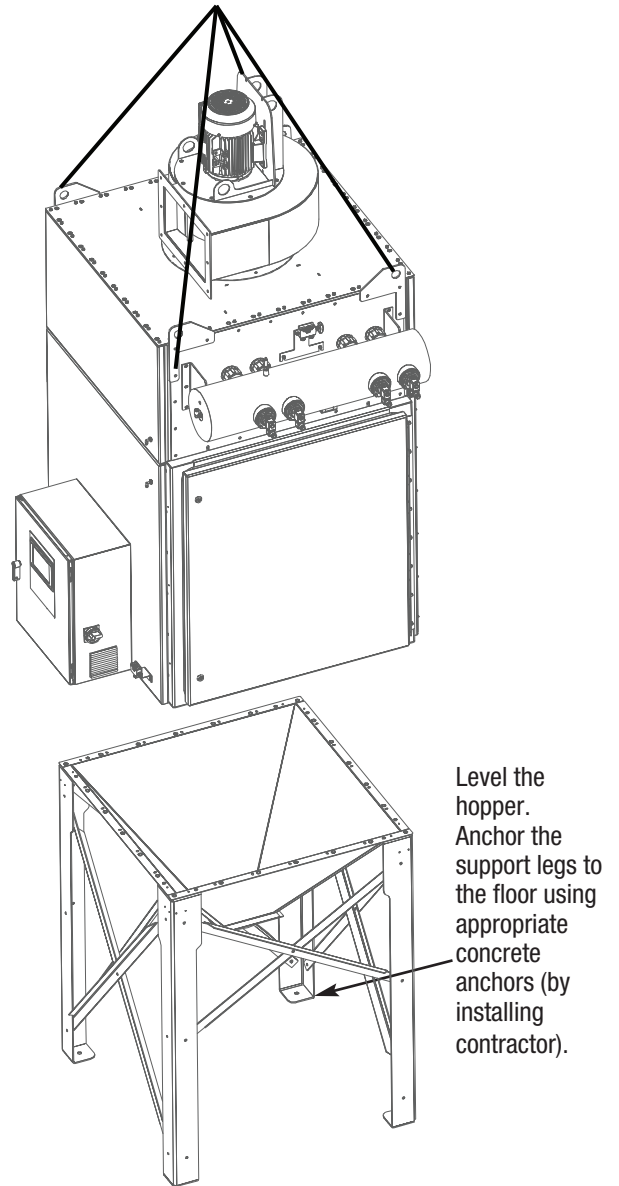

Thread 3/8" flange bolts from under hopper flange up into all interior rivet nuts (2 in each corner). These need to all be started before setting full weight of module on leg base. Secure module to leg base by installing all 1/4" flange bolts as shown below and tightening previously installed 3/8" bolts.

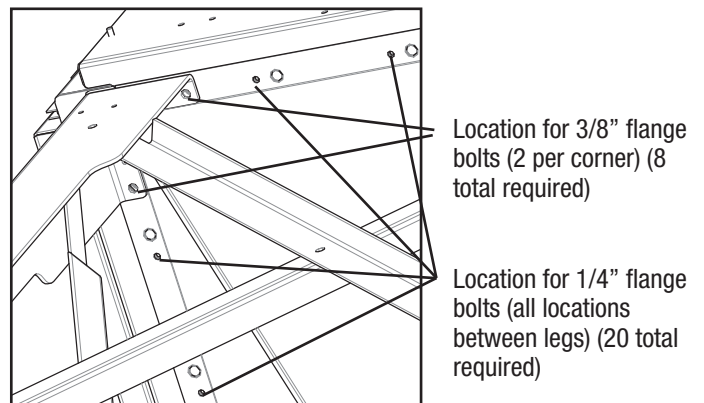

Step 4 – Install Fan Silencer

FIGURE A.6

Apply strip foam gasket on inside of bolt holes and overlap in corners. Install silencer using 3/8 bolts and nuts.

AD1326-17, AD1326-20, AD1326-27, AD1326-28, AD1326-29, AD1326-30: (8 BOLTS; 7 NUTS)

AD1326-18, AD1326-19, AD1326-21, AD1326-22, AD1326-31, AD1326-32, AD1326-33, AD1326-34: (10 BOLTS; 8 NUTS)

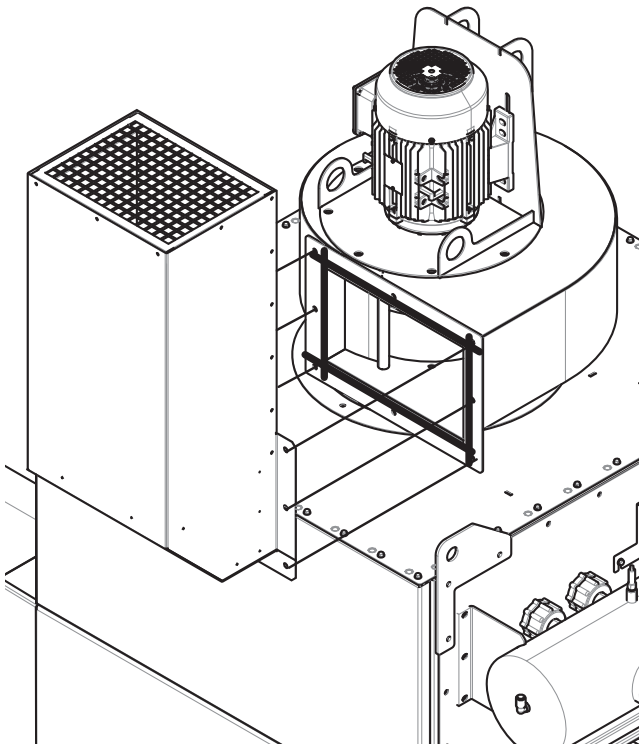

Step 5 - Drum Installation

- Carefully position the dust collection drum onto the wheel cart. See Figure A.7 Item A.
- Position the drum assembly under the hopper assembly.
- Connect the flexible duct from hopper to the drum using the hose clamp See Figure A.7 Item B.

FIGURE A.7

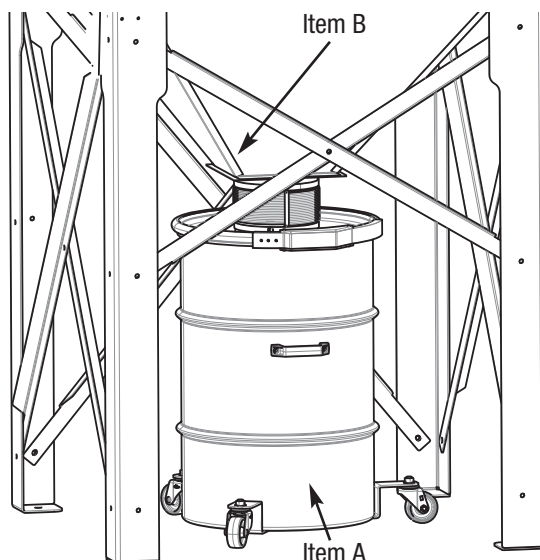

STEP 6 – COMPRESSED AIR CONNECTIONS

FIGURE A.8

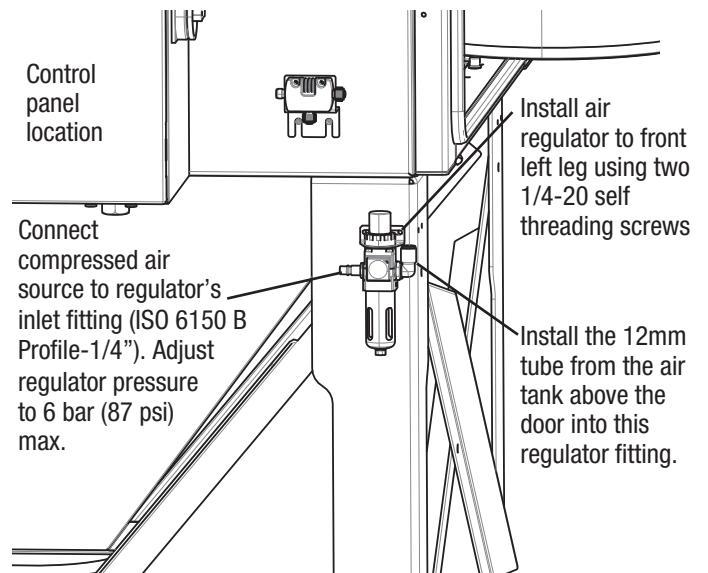

Step 7 – Install Pressure Sensor And Pitot Tube

- Drill 1/4" inch hole on the duct pipe 40-50" away from the inlet of the unit
- Insert Pitot tube and secure it with sheet metal screws (not shown)
- Install Differential Pressure Sensor next to the Pitot tube, See Figure A.9

FIGURE A.9

NOTE: Baffle inlet shown. See page A-2 for alternate pre-filter inlet duct orientations.

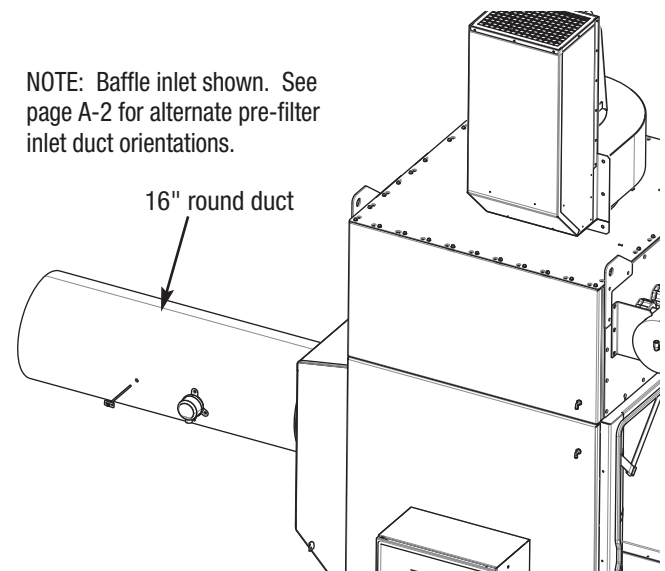

- Secure Differential Pressure Sensor using 3 sheet metal screws
- Connect the clear tube from Pitot tube to the -ve connection nipple (right side) of the sensor.
- Connect one end of the wire terminal to sensor PD2 & other end to the Control Panel at TB2. Refer to wiring diagrams in section F for connection details.

Step 8 - Install Filters (See section D for filter replacement instructions)

WARNING

Before opening door, unit must be off and the power switch on the side of the control panel turned to the off position.

a. Unlock door latches

FIGURE A.10

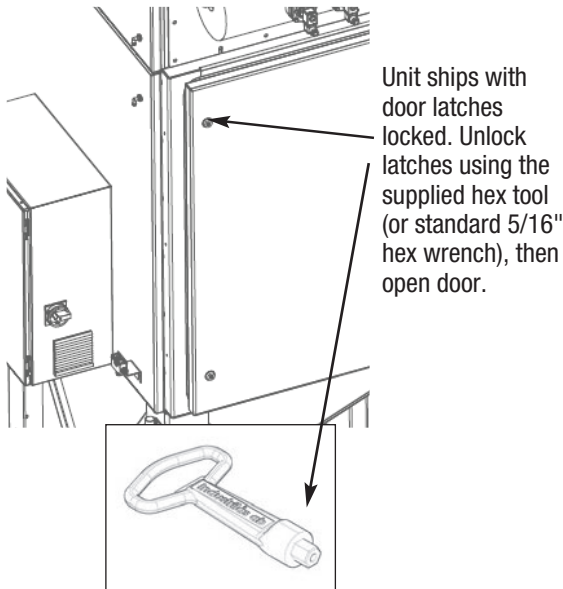

b. Unclamp filter handles

FIGURE A.11

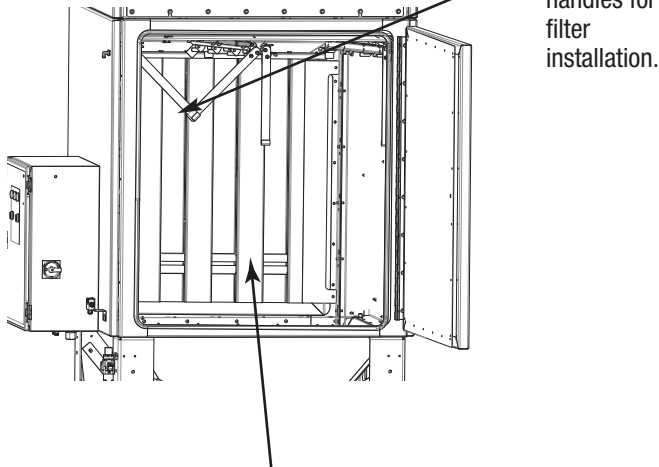

NOTE: Baffle inlet shown. Baffles replaced with pre-filters for alternate inlet models.

c. Install new filters.

FIGURE A.12

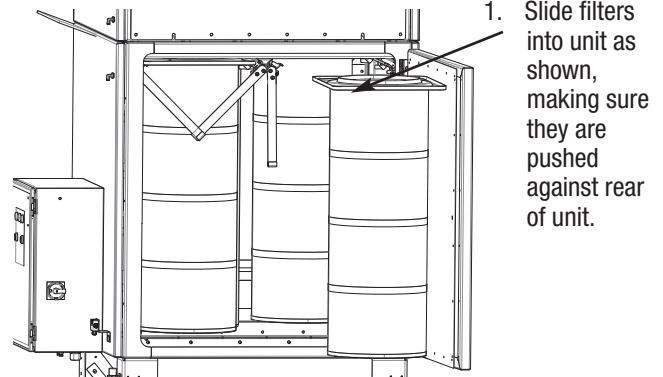

d. Reclasp filter handles

FIGURE A.13

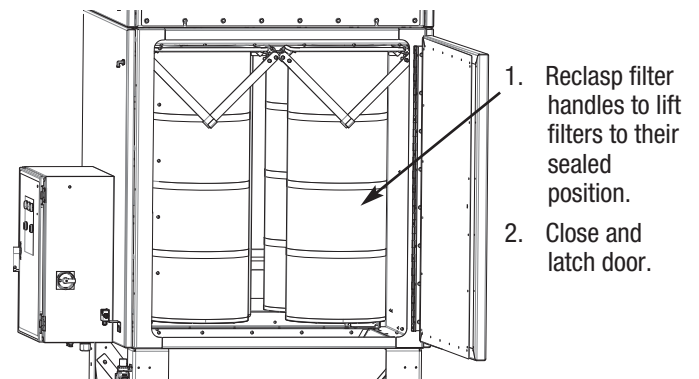

Step 9 - lock door

To prevent accidental door opening during unit operation, lock door latches using the supplied hex tool (or standard 5/16" hex wrench).

FIGURE A.14

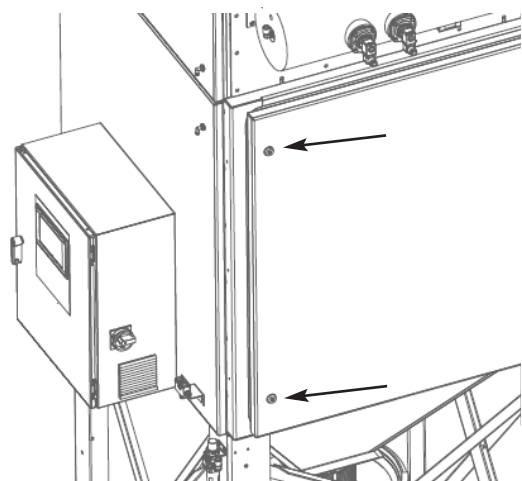

ELECTRICAL CONNECTIONS

Make all electrical connections compatible to your local city / state code.

WARNING

ELECTRIC SHOCK can kill.

- Only qualified personnel should perform this installation.
- Turn the input power OFF and unplug the machine from the receptacle before working on this equipment.
- Insulate yourself from the work and ground.
- Always connect the Prism® 4 to a power supply grounded according to the National Electrical Code and local codes.



WARNING

All electrical wiring which includes primary, secondary and control wiring must be done by certified/licensed electrician.

ELECTROCUTION HAZARD.

Disconnect mains before servicing. Failure to do so could result in serious personal injury or death.

Do not attempt installation of this unit unless you are familiar with the necessary tools, equipment, utility connections and potential hazards. Installation should be performed only by a qualified service provider. Failure to do so could result in reduced performance of the unit, serious personal injury or death.

RELOCATE CONTROL PANEL TO RIGHT SIDE

Review this manual for detailed instructions on the connection to the control panel.

The control cabinet ships mounted on the left side as shown in the unit illustrations. If required, it can be moved to the right side. The control panel must be fully disconnected from input power before performing these steps.

1. Drill holes in the right side dirty air panel. There are small center marks in the panel marking location or just mirror the left side holes to the right side. The holes required are: four 0.406" holes for the control panel and two 0.221" holes for the smart wire module bracket.
2. Disconnect the fan motor cable from the control panel, making sure to note wire color locations in the VFD.
3. Disconnect the green smart wire cable running from the smart wire module above the compressed air tank to the smart wire module next to the control panel.

4. Move the control panel and smart wire module to the right side. The module bracket should be next to the door and the module must be rotated 180° on the bracket so the "out" port points towards the door.
5. Rotate the smart wire module above the compressed air tank 180° on the bracket so the "out" port points to the right.
6. Reroute the green cable from the module above the compressed air tank to the module by the control panel. It should route down the right side by the door.
7. If the fan's silencer needs to move due to obstruction, the fan can be rotated but it is not required. If rotating the fan, the motor assembly needs to be rotated on the fan housing so the motor's connection box is on the back. The motor assembly can be rotated on the fan housing by removing the bolts on top of the fan housing.
8. Reroute the fan motor cable down the right rear of the unit and reconnect it to the control panel's VFD. Make sure to connect the proper color wire to its original location.
9. The air regulator can be moved to the right side also, but the compressed air tank's end fittings will need to be swapped.

NOTE: The open holes on the left side panel must be plugged. Bolts and nuts work well - 3/8-16 at the control panel location and 1/4-20 at the module bracket location.

OPERATION

Safety Precautions

WARNING

Only use the product for the welding processes described in the General Description. Avoid using the product for extracting and/or filtering fumes and gases which are released during the following (welding) processes:



Never use the product for:

- oxy-fuel cutting
- oil mist
- paint mist
- extraction of hot gases (more than 80°C/176°F continuously)
- grinding aluminium and magnesium
- flame spraying
- extraction of cement, saw dust, wood dust, grit etc.
- explosive environments or explosive substances/gases

(This list is not comprehensive.)

If the product is used in above situations it could result in potential fire hazard, non-compliance with local regulations and reduction in product performance and life.

USERS

The use of this product is exclusively reserved to authorized, well-trained and qualified users. Temporary personnel and personnel in training can only use the product under supervision and responsibility of skilled engineers.

WARNING

Worker exposure level should be checked upon installation and periodically thereafter to be certain it is within applicable federal, state and/or local regulations and guidelines (i.e. OSHA PEL and ACGIH TLV limits in the U.S.).

INTENDED USE

The product has been designed as a filtration unit for dry dust and fumes. Using the product for other purposes is considered contrary to its intended use. The manufacturer accepts no liability for any damages or injury resulting from such use. The product has been built in accordance with state-of-the-art standards and recognized safety regulations.

Only use this product when in technical perfect condition in accordance with its intended use and the instructions explained in the user manual.

MODIFICATIONS

Modifications of (parts of) the product is not allowed.

RESTRICTIONS

The Lincoln Electric "BANK" system may only be used for filtration of fumes and dust generated by some dry processing industries. Max 80°C (176°F) gas temperature.

WARNING

- During use, always use Personal Protective Equipment (PPE) to avoid injury. This also applies for persons who enter the work area.
- Check the working environment. Do not allow unauthorised persons to enter the working environment.
- Protect the product against water and humidity.
- Make sure the room is always sufficiently ventilated; this applies especially to confined spaces.

WARNING

Saturation or clogging of the filter cartridge results in a decrease of the extraction capacity which could result in a higher localized concentration of welding fumes.

The Lincoln Smart Connect™ controls will automatically maintain airflow via a PID loop controlling the DE1 Variable Speed Starter (VSS) motor speed so that it keeps the duct pressure consistent. The PID setting to maintain the required pressure and therefore airflow is set during installation of the unit. For changes to this setting contact Lincoln Electric Service.

CONTROL

The Eaton 2DD Smartwire I/O pack produces both an input and an output when connected to a robotic welding cell. When the unit is powered on and operating, the remote output will produce a 24VDC "running" signal. If dry contact is made between the input and 24V source line the System Start button on the HMI will change to REM RUNNING. Starting remotely prevents the local panel button from stopping the unit, as a maintained start signal will take precedence. For further details consult the "Smartwire Connections Diagram" in section "F" of this manual.

NOTE: when the unit's Alarm Light is illuminated the remote output will change to a pulsing high/low at a rate of approximately 1hz. For remote activation, the Robotic Welding Cell start/stop simulator feature may be utilized (see section "F" of this manual).

FIGURE B.1

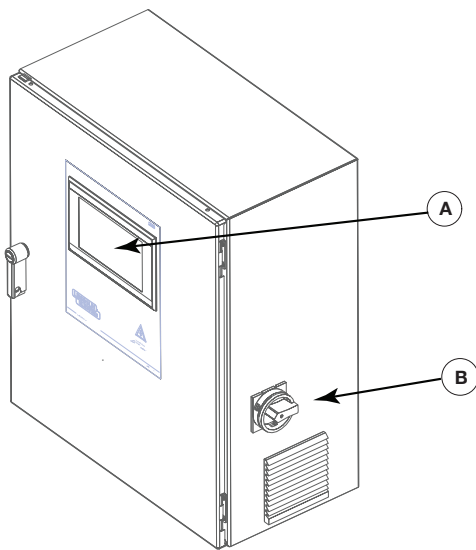

A. HMI Screen

B. Main Switch - Input Power

NOTE - Reference control panel label for wiring specifications

NOTE - Land power ground wire should be longer than all other wires

Control Panel HMI Navigation

Prism® HMI controller Overview

- The Prism® HMI controller has an embedded Programmable Logic Controller with easy to use visual interface and touchscreen control.

Functions

- Touchscreen interface
- Multi-level password security (Admin, Service, Maintenance)
- Easy to understand System & Cleaning configuration with built-in limits.
- Status screen showing VFD, System, and Smartwire status
- Alarm screen with historical logging
- Important system messages are displayed at the bottom of all screens
- Integrated Run Schedule for unattended Start/Stop operation
- Fan runtime hours counter
- Filter Life hours counter
- Fan kWh counter

HMI Screen Navigation Base Screen

- Accessible by All users

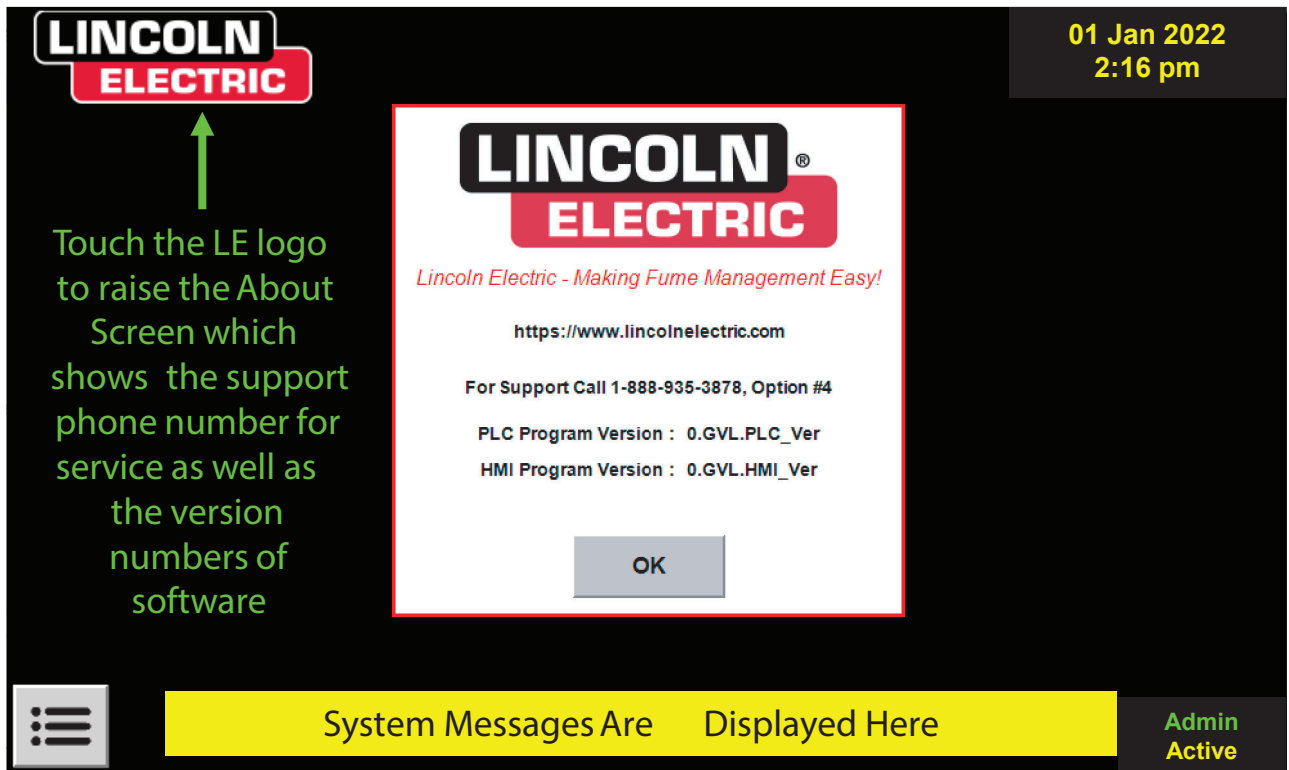

Touch the Lincoln Electric logo to raise the screen showing the support phone number and software version numbers.

- Accessible by All users

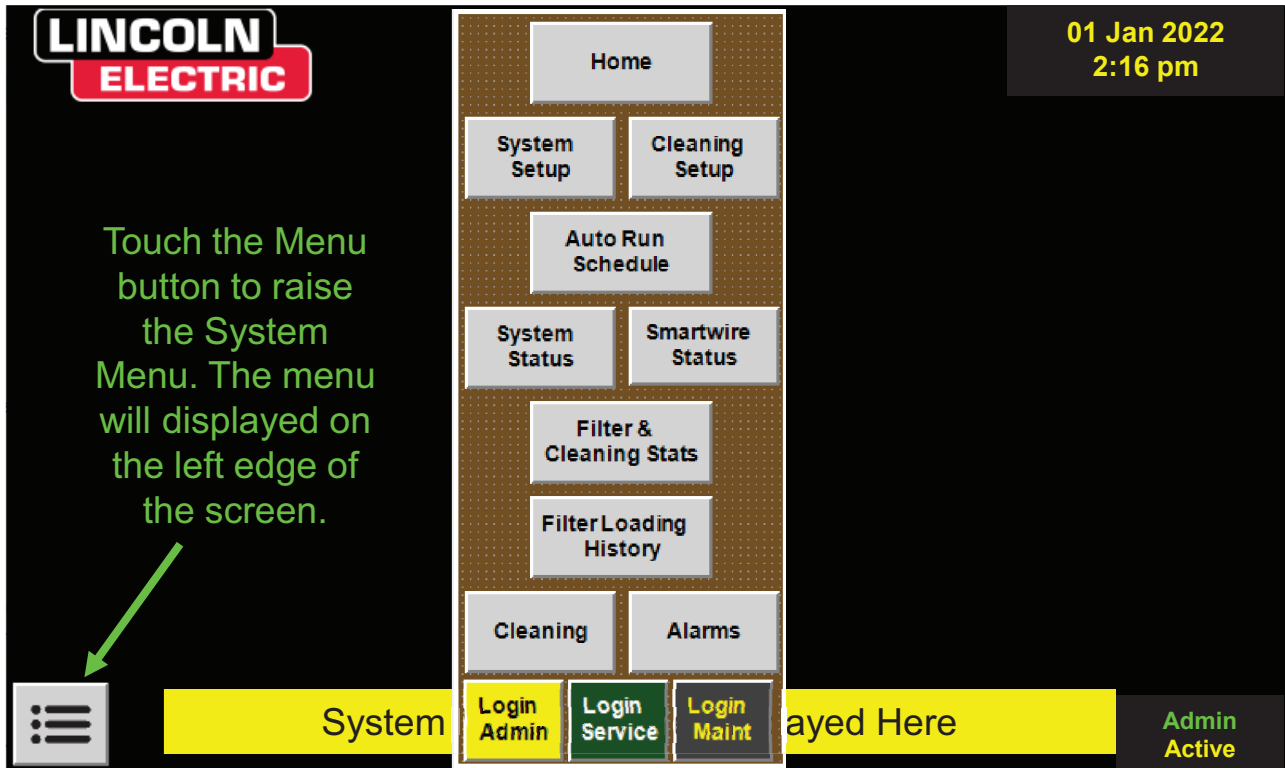

Touch the icon in the bottom left of the screen to raise the system menu.

- Accessible by All users

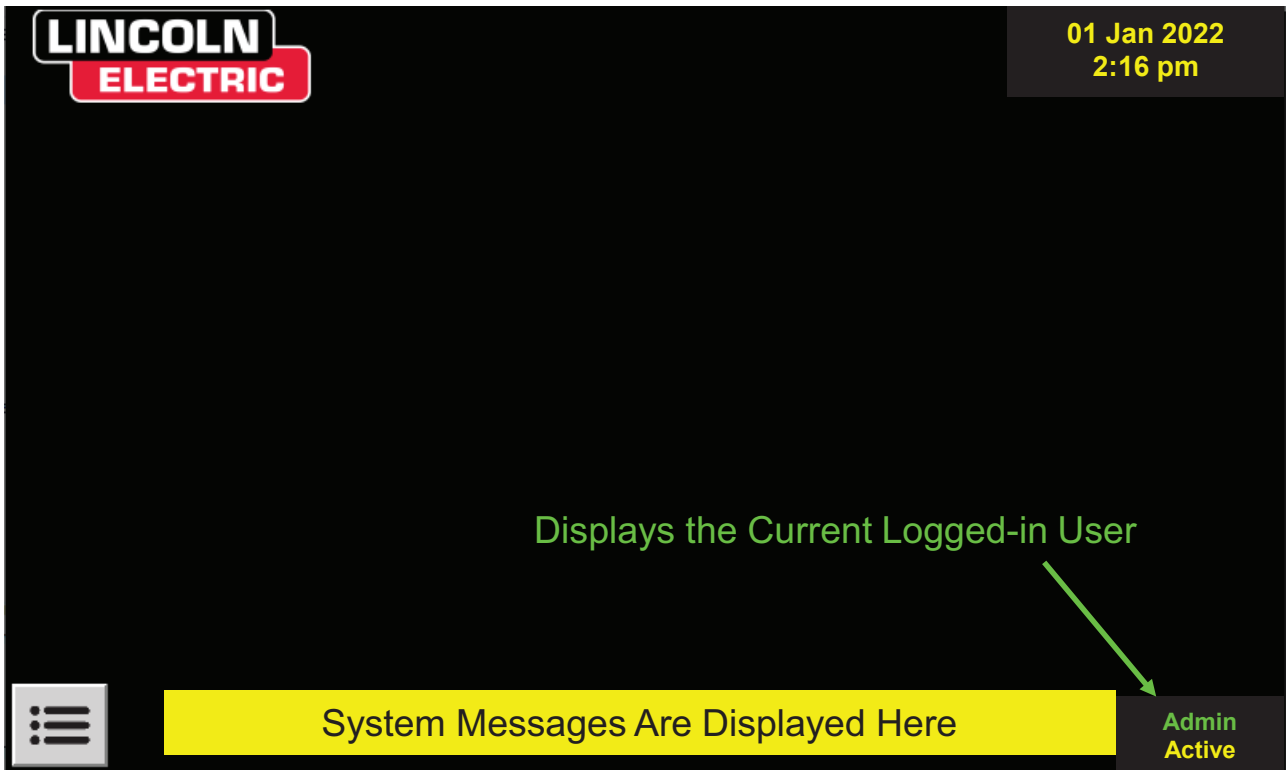

The current logged-in user is displayed in the lower right hand corner. Operator is the default user. Passwords are required for Maintenance, Service and Admin levels of access. System messages are displayed at the bottom of the screen.

Main Screen

- Accessible by All users

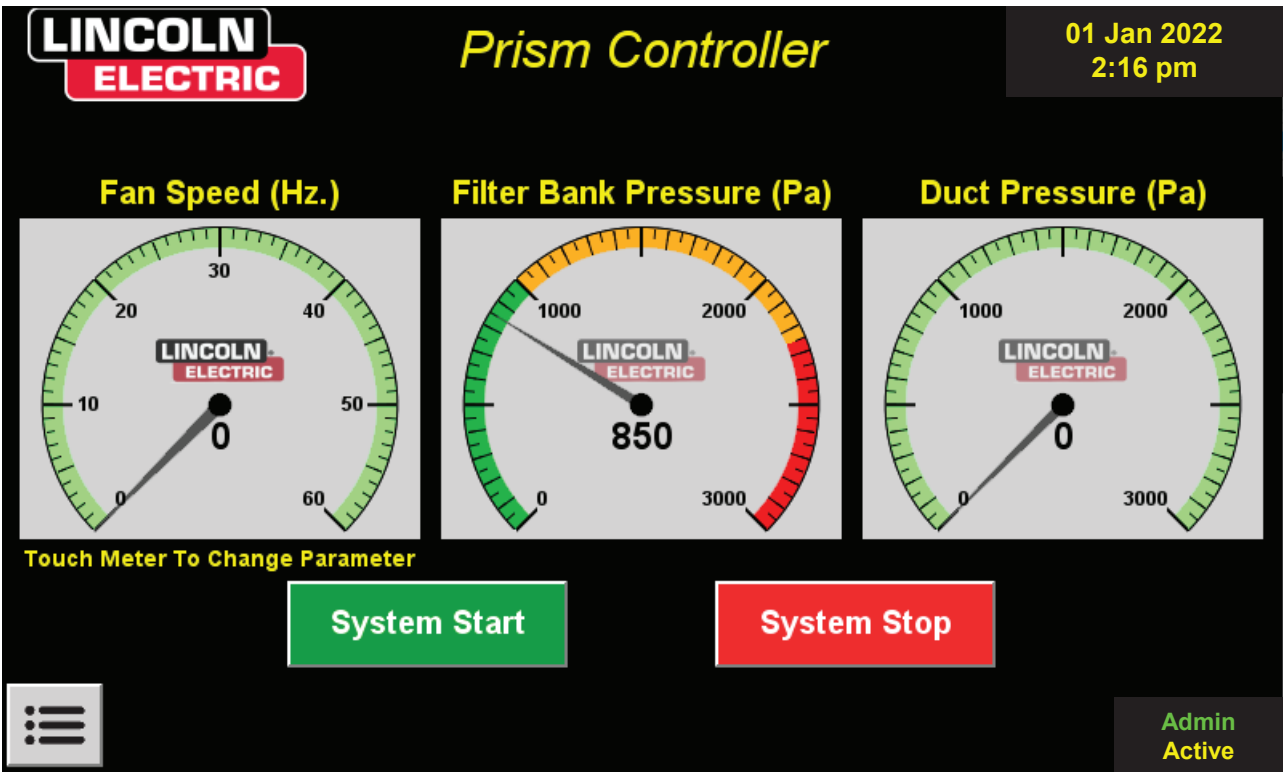

When the Run Schedule is NOT enabled, the system is started and stopped from this screen. It displays the pressure within the Prism unit as well as the pressure in the return duct and VFD Data. A user can touch the left meter to change the display to either Fan Speed, Motor Torque, Motor Power, or Bus Voltage.

- Accessible by All users

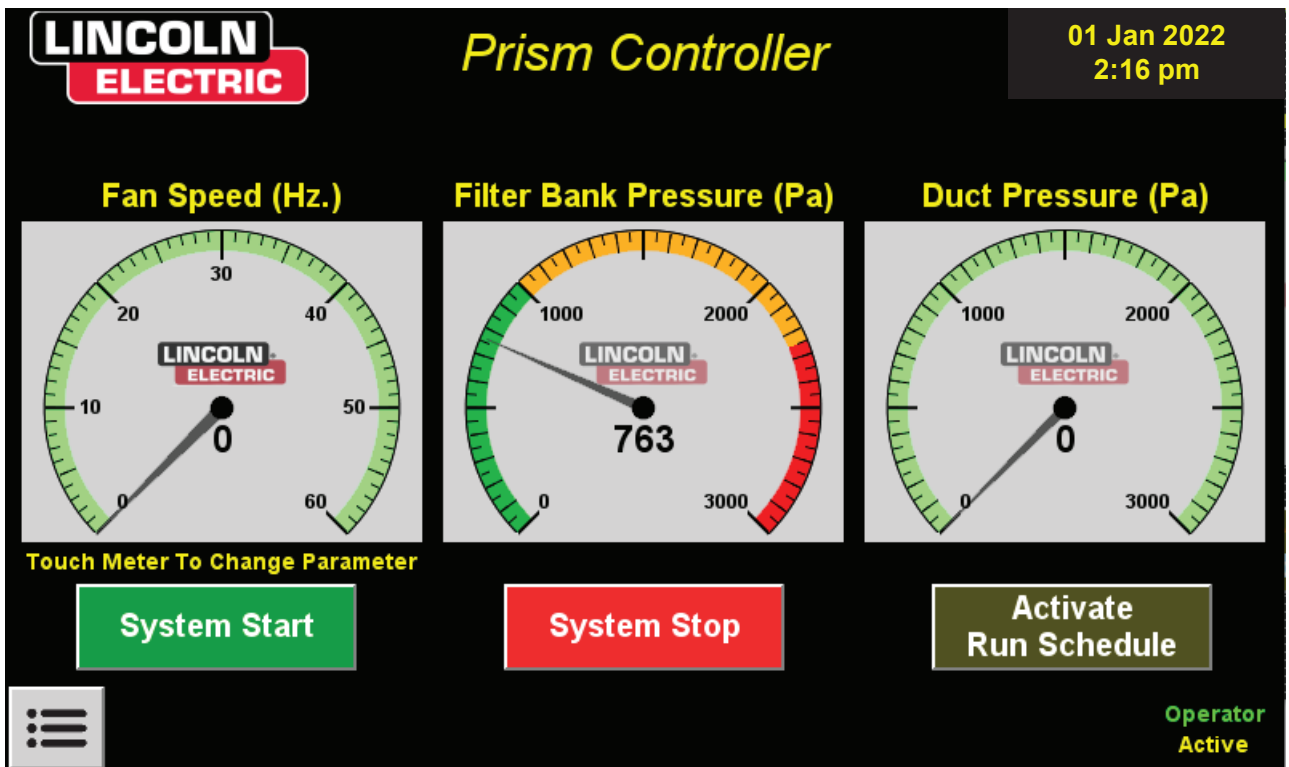

When the Run Schedule is enabled but NOT activated, the system will be started and stopped using the buttons on this screen.

- Accessible by All users

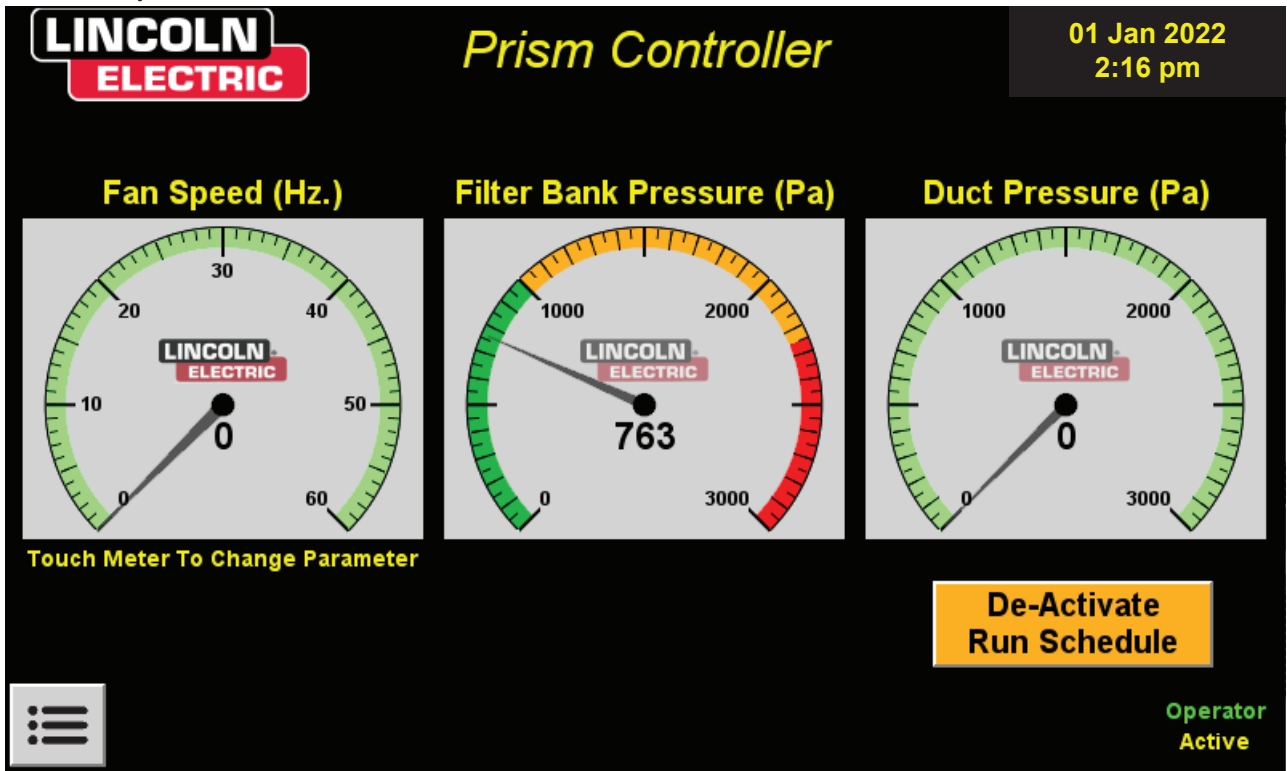

When the Run Schedule is enabled, the system starts and stops automatically based on the Run Schedule. Start and stop with buttons is no longer possible until you de-activate the Run Schedule.

The maintenance password (5555) is required to enable and disable the Run Schedule. A service password is required for some other functions and is only available through LECO service.

System Setup Screen

- Viewable by all users; Changes by maintenance, service and admin users only

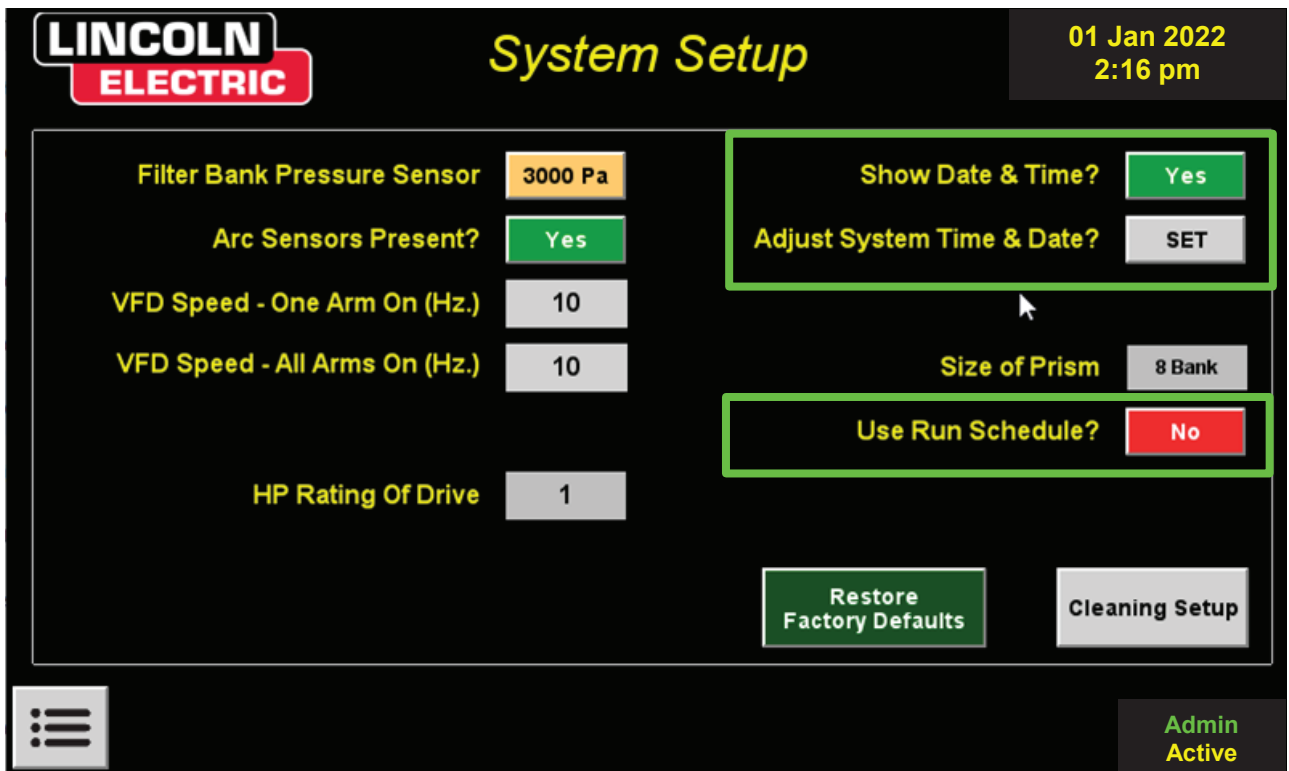

Maintenance users can adjust Date & Time settings and enable the Auto Run Schedule. Other parameters can only be adjusted by service personnel.

Cleaning Setup Screen

- Viewable by all users; Changes by service and admin users only

LINCOLN ELECTRIC *Cleaning Setup* 01 Jan 2022 2:16 pm

Low Press. Cleaning Threshold (Pa)	999	Delta P Threshold (Pa)	9999
Med. Press. Cleaning Threshold (Pa)	999	Delta P Reset Threshold (Pa)	999
Med. Pressure Cleaning Cycles	99	Delta P Cleaning Pulse Delay (sec)	999999...
High Press. Cleaning Threshold (Pa)	9999	Filter Warning (Pa)	9999
High Pressure Cleaning Cycles	99	Pulse Time (ms)	999
Offline Cleaning Pulse Delay (sec)	999999...	Manual Cleaning Cycles	99

Restore Factory Defaults System Setup

Admin Active

Cleaning setup parameters can only be changed by service personnel.

Auto Run Schedule Screen

- Viewable by all users; Changes by maintenance, service and admin users only

LINCOLN ELECTRIC *Run Schedule* 01 Jan 2022 2:16 pm

	Shift 1		Shift 2	
	Starts at	Stops at	Starts at	Stops at
Mon	0:00	0:00	0:00	0:00
Tue	0:00	0:00	0:00	0:00
Wed	0:00	0:00	0:00	0:00
Thu	0:00	0:00	0:00	0:00
Fri	0:00	0:00	0:00	0:00
Sat	0:00	0:00	0:00	0:00
Sun	0:00	0:00	0:00	0:00

Set Shift 1 Weekdays Set Shift 2 Weekdays Write Schedule To PLC

Maint Active

Touch each field to set the Start and Stop times for each shift on each day. Only maintenance users can adjust the schedule.

- Viewable by all users; Changes by maintenance, service and admin users only



Optionally you can touch Set Shift x Weekdays to set the Start and Stop times for that shift on each selected day.

System Status

- Viewable by all users; Changes by maintenance, service and admin users only.

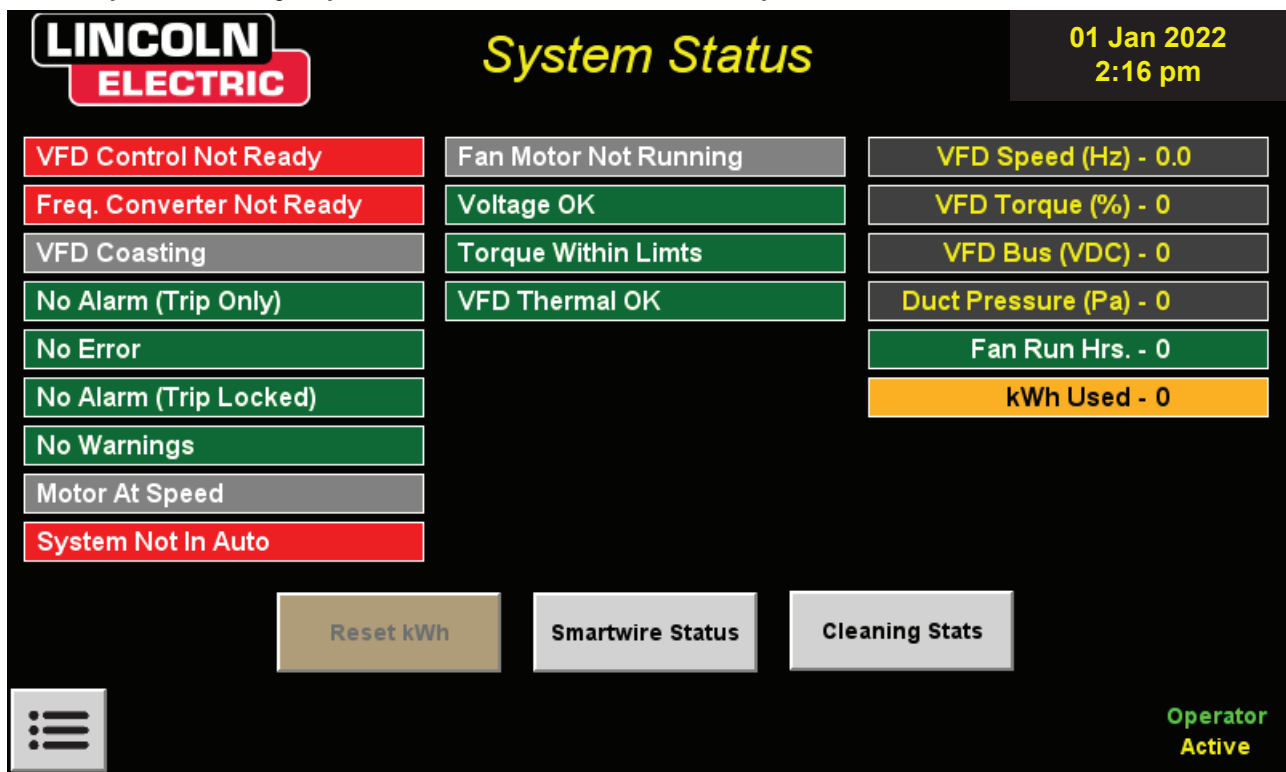

System screen displays status information received from the VFD. It also shows total run hours of the fan and kWh used. Maintenance personnel can reset the used kWh.

- Viewable by all users; Changes by maintenance, service and admin users only.

When a Thermal Suppression system is active the highlighted fields above will also be shown.

Smartwire Status

- Viewable by all users

Smartwire Network Status is shown here. If a module is missing or has been replaced with a NOP midule that status will show on the appropriate module.

Filter & Cleaning Stats

- Viewable by all users; Changes by maintenance, service and admin users only

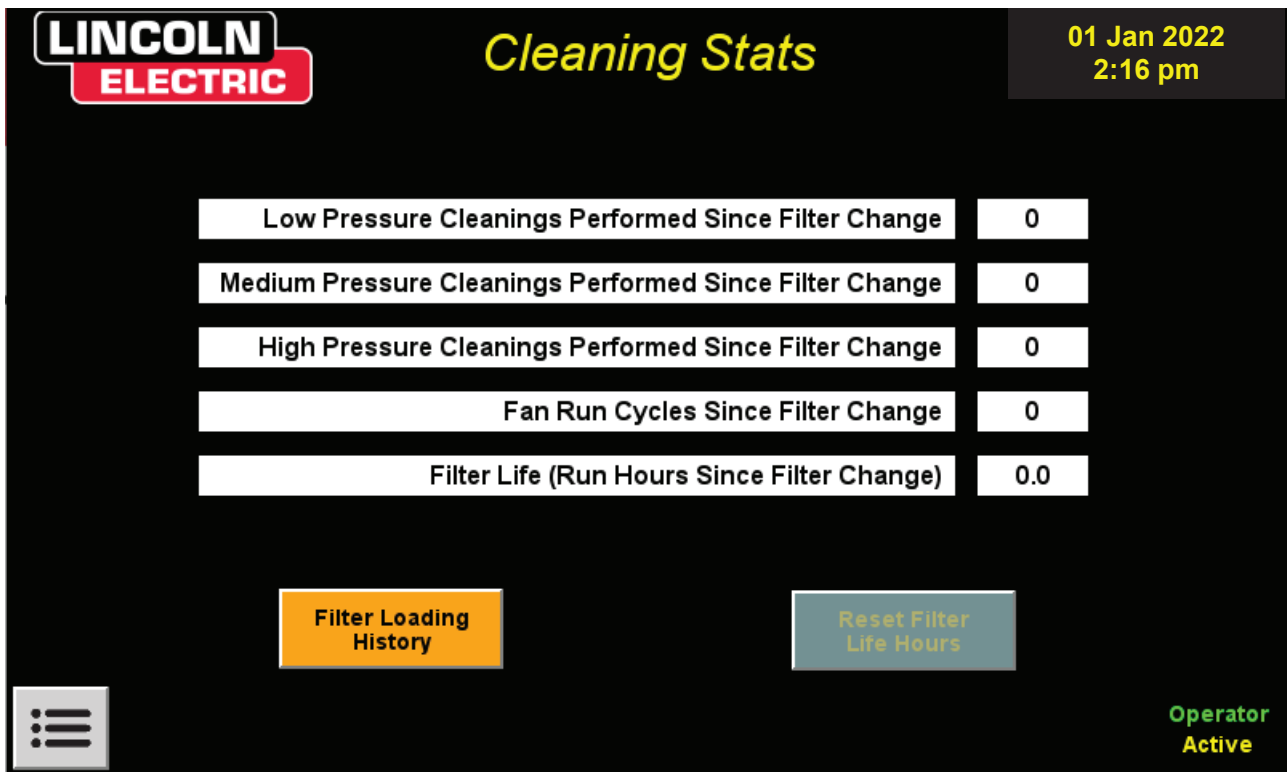

The number of cleaning cycles and run cycles plus the length of time since a filter change are shown here. Maintenance users can reset the filter life hours.

Filter Loading History

- Viewable by all users

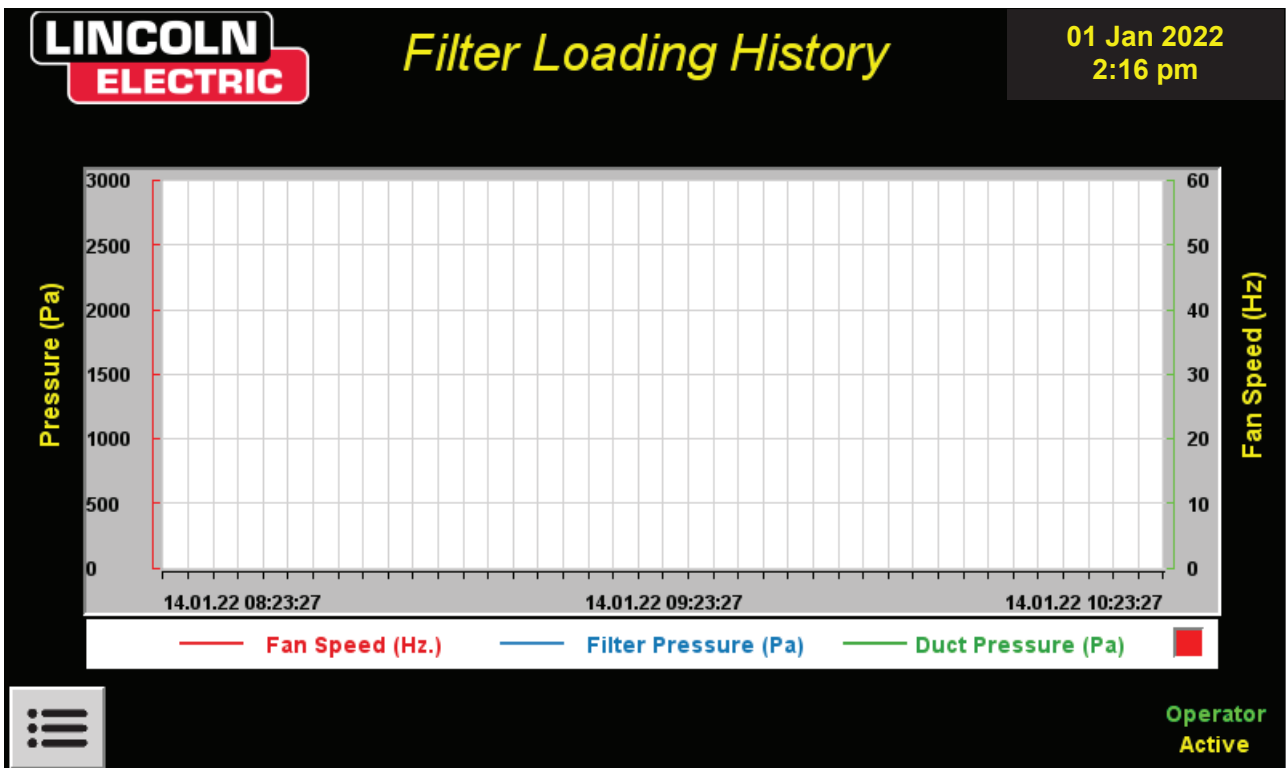

The graph tracks Fan Speed, Duct Pressure and Prism® filter pressure over time.

Cleaning

- Accessible by All users

The screenshot shows the 'Cleaning' interface. At the top left is the 'LINCOLN ELECTRIC' logo. The title 'Cleaning' is in yellow. The date and time '01 Jan 2022 2:16 pm' are in the top right. A progress bar for 'Time Until The Next Cleaning Pulse' is shown. Below it are four 'Cleaning Valves' (Valve 1, Valve 2, Valve 3, Valve 4) with status indicators: 'Valve Has Not Yet Fired' (tan) and 'Valve Has Fired' (green). To the right are 'Start Manual Cleaning' (green) and 'Stop' (red) buttons. At the bottom, it shows 'Cycles Completed - 0' and 'No. of Cycles To Run - 1'. The operator status 'Operator Active' is in the bottom right.

Cleaning can be initiated or monitored on this screen. Each of the valve boxes above will change from tan to green after its valve has fired.

Alarms and Warnings Screen

- Accessible by All Users; Changes by service and admin users only

The screenshot shows the 'Alarms & Warnings' interface. At the top left is the 'LINCOLN ELECTRIC' logo. The title 'Alarms & Warnings' is in yellow. The date and time '01 Jan 2022 2:16 pm' are in the top right. On the left are four navigation arrows (up, up, down, down). The main area contains a list of messages with timestamps and color-coded text: 'Errors are shown in RED', 'Acknowledged Errors are shown in GREY', 'Messages are shown in GREEN', and 'Warnings are shown in ORANGE'. At the bottom are buttons for 'Ack Selected', 'Ack All', 'Clear History', and 'Show History'. The operator status 'Operator Active' is in the bottom right.

Alarms & Warnings is a historical alarm logger. Only service personnel can clear the history.

SOFTWARE FUNCTIONS

The PRISM® 4 is controlled by a HMI with embedded PLC using Eaton Smartwire technology with the following software functions.

- 1) START/STOP FAN - Fan start/stop is controlled by one of four ways.
 1. Manual start/stop on HMI screen
 2. Auto scheduled start/stop set on HMI screen
 3. External switch
 4. Remote control
- 2) AUTOMATIC FILTER CLEANING -
 - a) Filter bank offline/online cleaning is dependent upon the differential pressure across the filters and your set points.
 - b) Offline cleaning occurs when fan is off.
 - c) Online cleaning occurs when fan is on.
 - d) Offline filter cleaning activates at three levels of filter pressure drop (low, medium, high). Each level gradually increases the amount of filter cleaning.
 - e) Low pressure default value is 400Pa, with an adjustable range of 200Pa to 600Pa. Medium pressure default value is 600Pa, with an adjustable range of low value +1 to 800Pa. High pressure default value is 800Pa, with an adjustable range of medium value + 1 to 1200Pa. Note: "Range" is the allowed value for each setting. A value above each set point activates cleaning at that level.
 - f) At the low pressure limit, the cleaning cycle is 2 rounds. At the medium pressure limit, the cleaning cycle default is 4 rounds with a range of 2-10. At the high pressure limit, the cleaning cycle default is 6 rounds with a range of 6-10.
 - g) When the fan is running, filter differential pressure is monitored. Once a level is reached, the system will wait for the fan to shut down before offline cleaning begins. Each valve is pulsed with compressed air in round robin fashion for the amount of cycles indicated for that level of cleaning. On some units, more than one valve is pulsed at a time. The default pulse time is 250ms. After the first valve is pulsed, the next one is delayed (default 15 seconds). The delay allows the air accumulator tank on the filter bank to refill.
 - h) If the fan is turned on before the cleaning cycle has completed, offline cleaning will discontinue. Once the fan is turned off, a new cleaning cycle will start.
 - i) Online cleaning is activated with the filter pressure drop settings. Default level is 1000Pa with a range of 1000Pa to 3000Pa. When the fan is running and the filter pressure set point has been reached, filter cleaning will start. The same pulse and pause times from the offline cleaning are used. Online cleaning will not stop until the filter pressure falls below the set point.
- 3) ALARMS - The PLC will trigger an alarm in the following cases.
 - a) The filter change alarm default is set at 2000Pa, with a range of 1500Pa to 3000Pa. When the filter differential pressure remains above this set point for 2 hours, the alarm is activated and the red alarm light will blink on the main control cabinet. At this time filters should be ordered from Lincoln Electric.

- b) Motor VFD faults and signals the control cabinet.
- c) Thermal suppression system malfunctions (if equipped).

- * The VFD alarm can be reset on the VFD's LCD display.
- * The filter change alarm only stops once the pressure across the filter is below the alarm set point.

FUNCTIONS OF THE PRISM® 4 FILTER UNIT:

- 1) Manual start/stop or auto schedule start/stop fan.
- 2) Remote start/stop of unit along with a "running" signal available that the remote Robotic Welding Cell can monitor.
- 3) Adjustable fan speed via a duct mounted pressure sensor and a PID loop that controls the motor speed with a Variable Frequency Drive (VFD).
- 4) Automated on line filter cleaning.
- 5) Automated off line filter cleaning.
- 6) Manual off line filter cleaning.
- 7) HMI alarm message:
 - a. Faulted VFD (Variable Frequency Drive).
 - b. Clogged filter.

OPERATION

Start/Stop Fan - Fan operation is controlled manually or by schedule on the HMI screen or with the remote Start/Stop. After fan shuts down, fan restart is delayed 30 seconds.

NOTE: Remote input takes precedence in operation. If the remote signal starts the unit, manual or scheduled start/stop on the HMI screen is disabled. The remote signal has to be removed (opened). This will allow the Start/Stop fan function on the HMI screen to function normally again.

Fan Speed and Operation - Fan airflow is set during installation by setting a PID set point in the VFD. The fan VFD uses a duct mounted pressure sensor which gives a 0-10 VDC signal to the controls. This provides a constant airflow to be maintained up to the limits of the fan during filter loading. The speed of the fan will be automatically adjusted between the minimum (20Hz) and maximum (60Hz) speeds. Consult the VFD operation guide, or contact Lincoln Electric service department for guidance with adjustment of the fan motor VFD parameters.

SMARTWIRE DEVICE LEARNING

FIGURE B.3

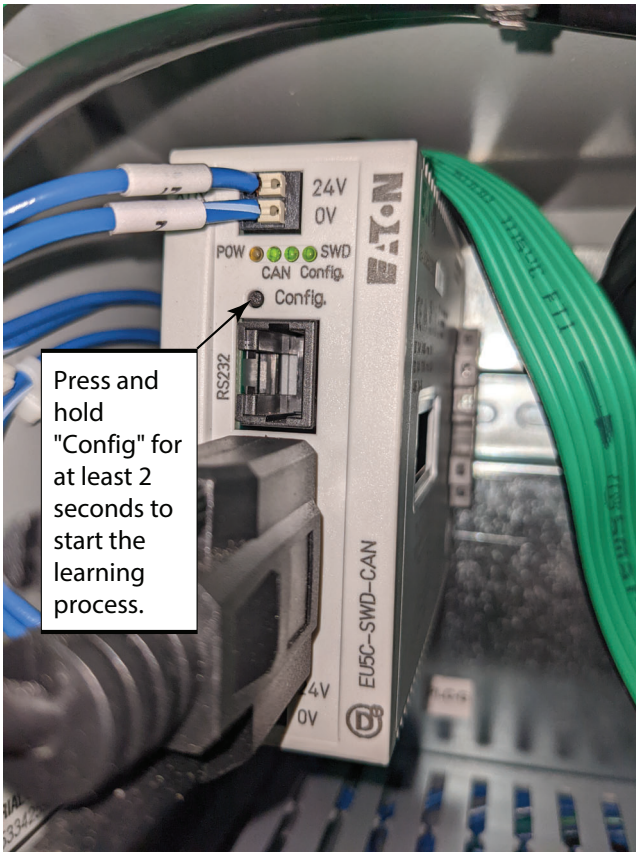

Device Learning: With everything connected (including the external I/O packs to the SWD4) press and hold down the "Config." button on the EU5C-SWD-CAN for at least 2 seconds. This should start the learning process where each module is matched for its type and serial number codes. If the codes do not match errors will appear. The ideal setting is to have solid green LED lights on all Smartwire components and the "POW", "Config" and "SWD" green LEDs illuminated above the "Config." button.

STARTUP

The following points are to be checked and implemented before the filter unit is put into operation:

Electricity - Check for connection to a proper three phase line voltage connection for optimal performance. The DE 1 Variable Speed Starter and Motor will be rated for the applied line voltage to the unit. Ensure supply lines to the unit are properly fused and all local electrical codes are followed.

Pneumatics - Check that the compressed air is connected. Compressed air should be clean, dry and oil free and at a maximum pressure of 87 psi (6 bar).

SET POINTS

Default values enable basic unit operation. Each value should be given consideration for optimized operation, and can be adjusted with continued use and experience using the equipment. Consult Lincoln Electric Field Service to shorten the learning curve. Of vital importance is the initial PID value setting for the airflow. This setting determines the unit's cubic feet per minute (cfm) the fan maintains as it monitors the duct pressure, and this ramps up fan speed as the filter loads and creates a higher differential pressure across it but maintaining system air cfm up to the limit of the fans maximum speed.

The Lincoln Electric Smartwire standard control cabinet comes with automatic controlled frequency converter. After the airflow is set with the PID setting the system will automatically adjust its self.

ACCESSORIES

REPLACEMENT FILTER OPTIONS

- **KP4519-1:** MERV 11 spun bond polyester filter cartridge
- **KP4519-2:** MERV 16 high efficiency nano fiber filter cartridge
- **KP4519-3:** MERV 16 high efficiency thermal bonded PTFE membrane filter cartridge
- **KP4519-4:** MERV 11 spun bond polyester filter cartridge with oil resistant technology
- **KP4519-5:** MERV 16 high efficiency nano fiber filter cartridge with oil resistant technology
- **KP4680-1:** Pre-Filter (set of 2)

All filters should be replaced at the same time; all should be of the same type. Replacement filters include dust mask, gloves and plastic bag (for spent filter).

OTHER ACCESSORIES

- **S31228-783:** Programmable Timer
- **S32715-479:** Thermal Suppression Local Alarm Interface Kit

**PRISM® THERMAL SUPPRESSION OVERVIEW
(AD SERIES ONLY)**

(AD1326-20, AD1326-21, AD1326-22, AD1326-28,
AD1326-30, AD1326-32, AD1326-34 ONLY)

The Prism® indirect low pressure thermal suppression system uses an extinguishing agent commonly known as Novec 1230. It is a colorless low odor fluid, low in toxicity, electrically non-conductive, leaves no residue, and is an extremely effective fire suppression agent.

The unit utilizes a UL recognized component (per UL standard 521), a Linear Heat Detector known as Firetrace Automatic Fire Detection Tubing, which when pressurized with Dry Nitrogen, will allow the fire suppression valve to remain in the closed position. This tubing acts as a continuous linear thermal detector that ruptures upon direct flame impingement or at temperatures above 212°F when pressurized to 195 psi. Once the detection tubing is ruptured, the valve automatically opens, allowing the Novec 1230 agent to flow through the discharge piping, distributing the extinguishing agent through the nozzles into the protected volume.

When the system's smoke detector is activated or the detection tubing is ruptured, the integrated controls quickly shut down the fan and close the two dampers to create a protected volume.

A LED strobe light provides visual notification of any system discharge. The stack light also gives visual feedback on any system malfunction as detailed in the Operations and Diagnostics section.

The thermal suppression system components are identified on page C-2.

NOTE: Baffle inlet shown. See page A-2 for alternate pre-filter inlet duct orientations.

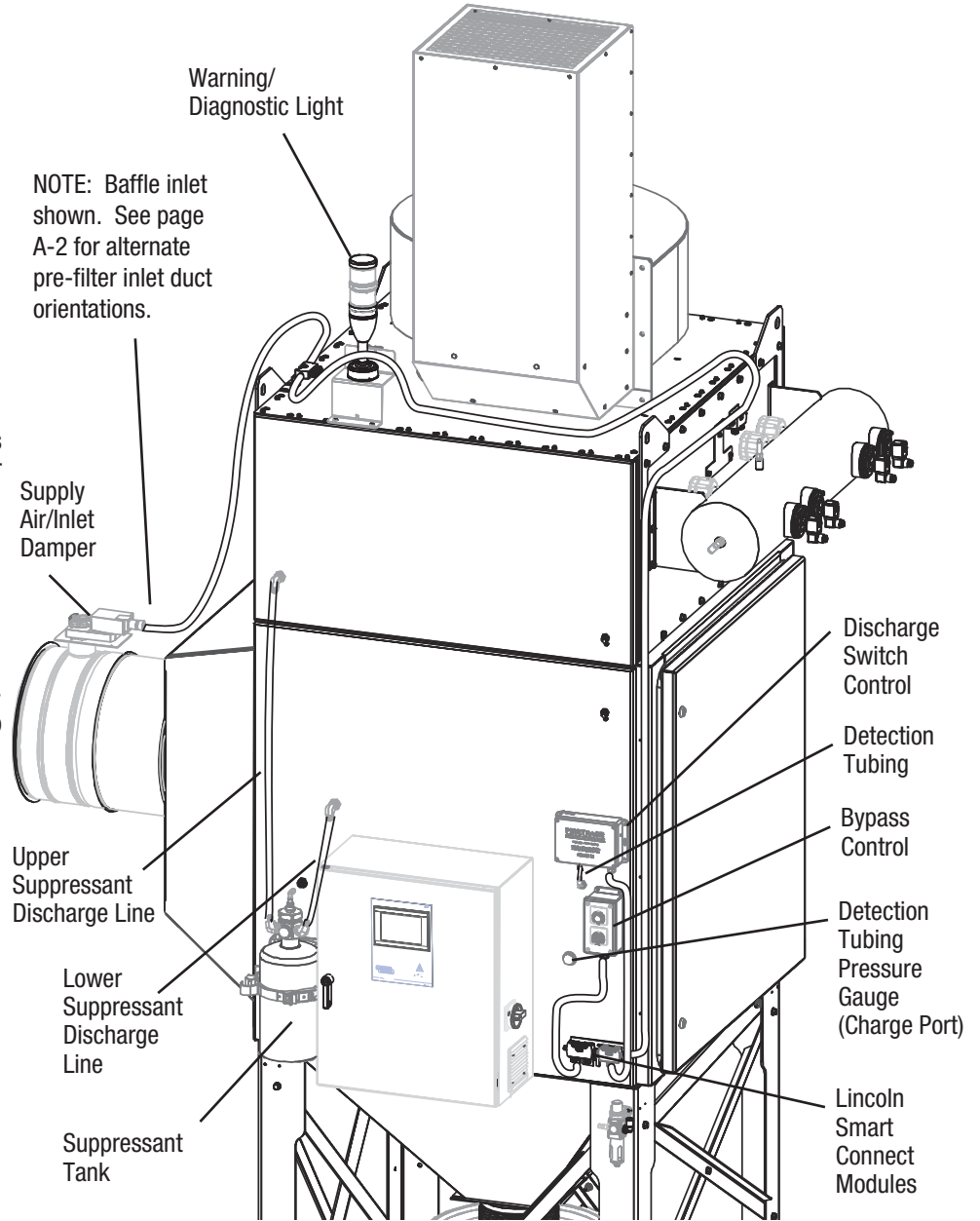

Lower Discharge Line Lower Suppressant Discharge Nozzle

Detection Tubing

Upper Suppressant Discharge Nozzle

Exhaust/Return Air Damper

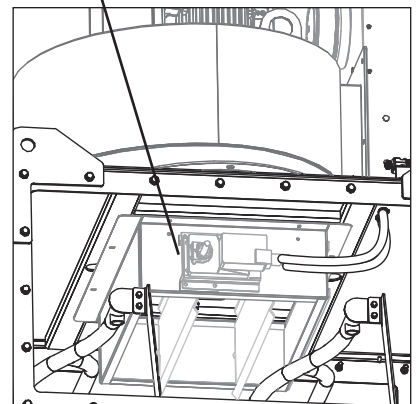
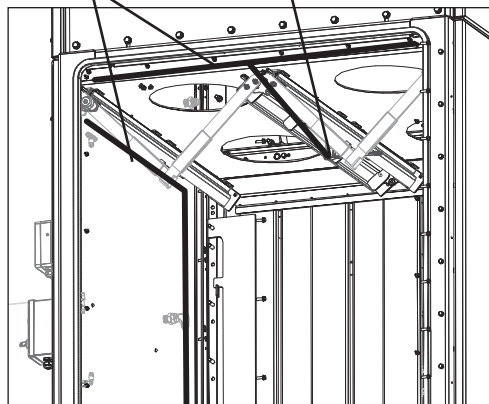
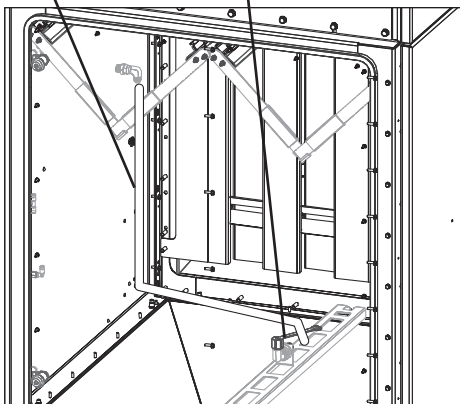

INSTALLATION

STEP 1 – Install stack light to base on top of unit. Twist clockwise to lock in place.

STEP 2 - Connect smoke detector wire to Lincoln Smart Connect Module on top of unit as shown.

STEP 3 – Install 16” round inlet damper within 10’ of the unit’s inlet plenum.

STEP 4 – Wire Smart Connect Module on top of unit to inlet damper module with supplied 5m long green cable.

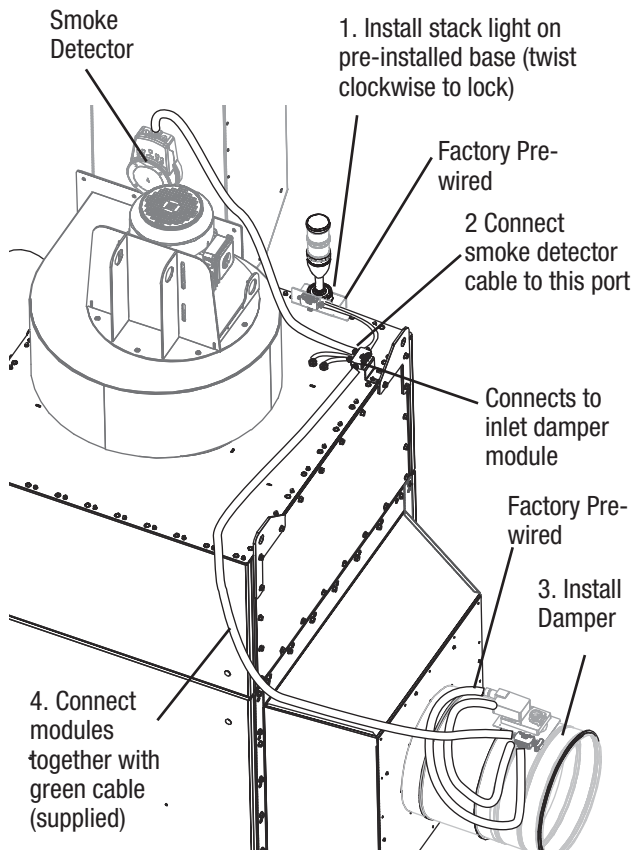

NOTE: Baffle inlet shown. See page A-2 for alternate pre-filter inlet duct orientations.

ACTIVATION

STEP 1 – With the ball valve on the suppressant tank still closed, remove the detection tubing pressure gauge and replace with the filling adapter included in the Nitrogen charge kit. Nitrogen charge kits are available through your Lincoln sales representative.

STEP 2 – Using a regulated nitrogen supply, pressurize the detection tubing through the filling adapter to 195 psig (10.3 bar).

STEP 3 - Remove the filling adapter and thread the pressure gauge & O-ring into its place to verify that the tubing is pressurized to at least 195 psig. This is the normal pressure at 70°F. Pressure will drop at lower temperatures.

STEP 4 – Wait 30 minutes and then observe the pressure gauge. Any decrease in pressure is an indication of a leak. Locate the leak using a soapy water solution at each of the red detection tubing connection points. Fix the leak, then recharge the system.

STEP 5 – After confirming there is no leakage in the detection

tubing, SLOWLY rotate the tank’s ball valve lever counter clockwise to the “ON” position.

CAUTION: If the ball valve lever is opened abruptly, activation of the cylinder valve may occur, causing the unit to discharge

STEP 6 – Tamper proof the unit by removing the ball valve lever, then screwing the tamper-proof clip to the valve. Complete installation of clip by using zip tie through clip’s backside holes. The unit is now fully armed and ready for use.

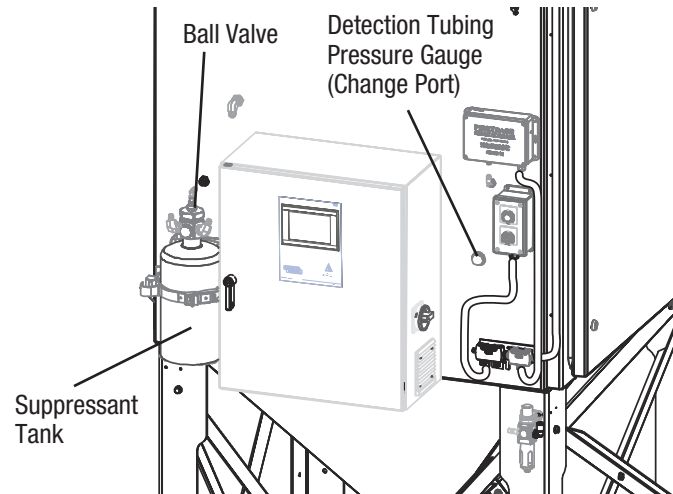

Valve shown turned to “on” position. Remove handle to install locking clip

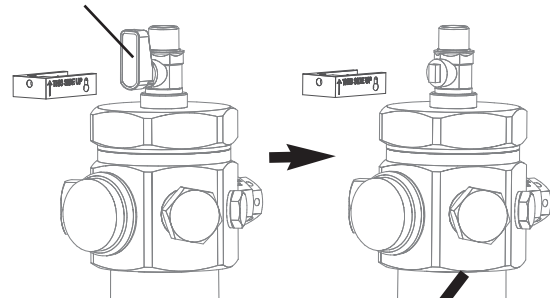

Screw clip to valve

Zip tie through holes on both sides

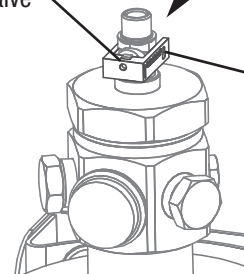

OPERATION & DIAGNOSTICS

NORMAL OPERATION DESCRIPTION

A Prism® with thermal suppression has active protection even during a power outage since a discharge of suppressant is exclusively dependent on heat induced rupture of the detection tubing. The detection tubing is routed through the filter (dirty air) side of the filter bank. Intake and exhaust dampers are used to contain an event and maximize the effectiveness of a suppressant discharge. A smoke detector shuts down the fan motor and closes the dampers if smoke or particulate due to bypass of a damaged filter is detected in the fan exhaust but this will not trigger a discharge since that can only be caused by heat from a thermal event.

B. FAN/DAMPER SHUTDOWN

There are three alarm conditions that will cause the fan to shut down and the dampers to close. The first cause is a smoke detector alarm, the second is heat induced rupture of the detection tubing and third a damper failing to signal that it is open.

The lower of the two stack lights (on top of the Prism®) will activate on any thermal event alarm and give a pulsed code of the type of alarm condition that the unit saw to cause it to shut down. A set of pulses followed by a 3 second off time can be decoded according to the alarm codes chart. If there are no system malfunctions, the dampers close when the fan is turned off. Offline cleaning initiated when the fan is shut down will delay damper closing until the cleaning is complete.

C. DISCHARGE NOTIFICATION

Flashing of the Stack Light's upper high intensity light indicates there has been a suppressant discharge. A set of pressure switches are contained in a Firetrace dual pressure switch box. The 195psi normal charge on the detection tubing keeps the discharge switch open. A significant loss of pressure caused by detection tubing rupture, closes the switch which triggers system shutdown and stack light visual notification.

D. SYSTEM MALFUNCTION ALARMS

The Prism® Thermal Suppression system monitors important functional conditions and provides visual display of any fault by flashing a pulsed code on the LED stack light's lower light. There are four coded alarms.

Inlet and exhaust damper alarm. Dampers are closed when the fan is off but are triggered to open when the fan is started. After opening, the damper's actuator switch sends a verification signal that they are opened. If a signal is not received within 10 seconds, the fan is shut down and a coded flash of pulses identifies which damper failed to open.

The dual pressure switch box monitors pressure in the red detection tubing. If the pressure drops too low due to a slow leak or low temperature, it trips a pressure switch and flashes a coded pulse on the lower stack light.

The smoke detector alarm triggered by smoke or particulate bypassing the filters triggers a coded pulse on the lower stack light

E. ALARM ACKNOWLEDGE/BYPASS CONTROL

To allow continued system operation, two of the alarms can be temporarily bypassed using the key switch box - the smoke detector alarm and low pressure in the detection tubing circuit. Note the important caution statements listed in the troubleshooting section. Damper alarms can not be bypassed since both dampers must be open for the fan to move air through the unit. The discharge alarm can not be bypassed either since the cause of this alarm must be resolved and the system reconditioned prior to additional use. Bypass mode is identified when the lower light on the stack light is solid red.

F. RESOLVING ALARMS

Identify the alarm using the "Prism® Stack Light Alarm Codes" table, then use the troubleshooting section to resolve alarm codes. When you have any alarm with a coded pulse on the stack light's lower light, there are some ways the controls are helpful to assist in troubleshooting. The signals for damper open switch, discharge switch input, service pressure switch input, smoke detector input are all digital IO inputs into modules that have LED lights indicating the status of that input. These are located next to the M12 cable connection for the module. Use the system wiring print to make sure cables are connected to the correct IO module input. Damper feedback function can be verified by manually moving a damper (black button is a clutch on the damper actuator) and watching the LEDs on the module to confirm the input is "seen" by it.

It is possible to have multiple alarm conditions, but only one code can flash at a time. Resolving one and clearing it will allow the flashing of any unresolved alarm conditions. Resolving all alarms must be completed before the controls will allow a normal startup.

DISCHARGE AND RECOVERY

INSPECTION

In the event of a discharge of the thermal suppression system, all components of the system must be inspected and any damaged or compromised components replaced. Un-ruptured red detection tubing can be reused only if there is no evidence of heat damage. That also applies to interior detection tube fittings containing internal seals that can be compromised by exposure to high heat. The suppressant tank has a pressure gauge that should show zero after a discharge. It will need to be re-charged or replaced. If there is any evidence of high heat exposure on any system components they must be replaced.

B. REPLACEMENT

For quick repair, it is advisable to keep a stock of internal replacement parts along with a spare suppressant tank. Replacement parts can be ordered through Lincoln Electric. Detection tubing is the heart of system and special attention should be made to replace it with the same lengths/routing/locations. Altering from the factory installed method can affect the systems ability to properly react to any future thermal event. The suppressant tank can be re-charged by the manufacturer instead of discarding it. A local distributor can be located at the following website:
<https://www.firetrace.com/find-a-firetrace-distributor>

C. RECOMMISSION

After the system has been repaired, it must be re-commissioned. This can be done by a Lincoln Electric Field Service Technician. A proper nitrogen charge kit can be used to recharge the detection tubing yourself and complete the steps to return the unit to full operation. Contact the Lincoln Electric Service department if you need help/guidance with any of the steps outlined here.

ALARM IDENTIFICATION AND TROUBLESHOOTING

Prism Stack Light Alarm Codes

LIGHT CODE	ALARM/CONDITION	PRIMARY CAUSE (See Alarm Troubleshooting and Resolutions)
1 - Lower Light: One flash with 3 seconds delay	Service Input Alarm	Detection tubing pressure too low
2 - Lower Light: Two flashes with 3 seconds delay	Smoke Alarm	Smoke/particulate detected in fan exhaust
3 - Lower Light: Three flashes with 3 seconds delay	Intake Damper Alarm	After fan is started, intake damper fails to open within 10 seconds
4 - Lower Light: Four flashes with 3 seconds delay	Exhaust Damper Alarm	After fan is started, exhaust damper fails to open within 10 seconds
Upper High Intensity Light: Continuous Flashing	Discharge Warning	Suppressant discharge detected
Lower Light: Solid red	Bypass Mode Engaged	Keyed switch turned to bypass

NOTE 1: Multiple codes can be stored. In these instances, clearing first code will reveal remaining code(s). Highest (first) priority is code 1.

NOTE 2: Both the upper discharge warning light and lower coded lights can flash at the same time

NOTE 3: All alarm codes will also trigger a solid red alarm light on the main control panel

ALARM TROUBLESHOOTING AND RESOLUTION

ALARM	POSSIBLE CAUSES	RECOMMENDED COURSE OF ACTION
Service input Alarm	1. Detection tubing pressure too low (below 160psi) due to leaks. 2. Detection tubing pressure too low (below 160psi) due to low temperatures (below 37°F).	1. Verify system pressure on gauge to right of main control panel or gauge on suppression tank. If it falls below green target proceed to step 2. 2. Check the detection tubing circuit for leaks. Repair and then recharge the circuit with Nitrogen to 195psi as described in the activation section. Verify pressure holds for at least 30 min. 3. Press reset on main control panel. The unit is now ready for operation. 1. Enable temporary bypass until ambient temperatures around unit rise above 37°F. Enabling Temporary Bypass (until cause is resolved) 1. Turn keyed switch to "Bypass" 2. Hit reset on main control panel CAUTION: Resolve low pressure due to leaks as soon as possible. Further loss of pressure can lead to a discharge alarm (without an actual suppressant discharge) that disables the unit and requires the suppressant tank to be reconditioned or replaced. 3. To return to normal operation, turn keyed switch back to "Enable" and then press reset on the main control panel.
Smoke Alarm	1. Smoke detector senses smoke or particulate in fan exhaust	1. Verify source of alarm and resolve. Both smoke and bypass of particulate due to filter damage can be sources for alarm. 2. Press reset on smoke detector body. 3. Press reset on main control panel. The unit is now ready for operation. Enabling Temporary Bypass 1. Turn keyed switch to "Bypass" 2. Hit reset on main control panel. CAUTION: Resolve cause of alarm as soon as possible to maintain early detection feature provided by the smoke alarm. 3. To return to normal operation, turn keyed switch back to "Enable" and then press reset on the main control panel.
Intake Damper Alarm	1. After fan is started, intake damper fails to open in 10 seconds. Damper's actuator switch fails to signal damper is open.	1. Repair damper. Possible causes include failed actuator, failed actuator switch, obstruction in damper, loose actuator connection to damper. 2. Press Firetrace "Silence/Reset" button twice. 3. Press reset on main control panel. The unit is now ready for operation. Contact a Lincoln Electric technician for possible temporary resolutions.
Exhaust Damper Alarm	1. After fan is started, exhaust damper located under fan fails to open in 10 seconds. Damper's actuator switch fails to signal damper is open.	1. Repair damper. Possible causes include failed actuator, failed actuator switch, obstruction in damper, loose actuator connection to damper. 2. Press Firetrace "Silence/Reset" button twice. 3. Press reset on main control panel. The unit is now ready for operation. Contact a Lincoln Electric technician for possible temporary resolutions.
Discharge Warning	1. Suppressant discharge triggered by heat induced rupture of detection tubing. 2. Extremely low detection tubing pressure.	1. Repair unit as required and recondition as described in the discharge recovery section. 2. Press Firetrace "Silence/Reset" button twice. 3. Press reset on main control panel. 1. Repair detection tubing circuit as described in the "Service Input Alarm" section. The suppressant tank will need to be reconditioned or replaced.

MAINTENANCE

⚠ WARNING

Have qualified personnel do the maintenance work. Turn the power off before working inside the machine. In some cases, it may be necessary to remove safety guards to perform required maintenance. Remove guards only when necessary and replace them when the maintenance requiring their removal is complete. Always use the greatest care when working near moving parts.

If a problem cannot be corrected by following the instructions, contact your local Lincoln Electric representative for service options or contact Lincoln Electric Customer Service.

ELECTRIC SHOCK can kill.

- Do not touch electrically live parts or electrode with skin or wet clothing.
- Insulate yourself from work and ground.
- Always wear dry insulating gloves



FUMES and GASES can be dangerous.

- Use in open, well ventilated areas or vent exhaust outside.



MOVING PARTS can injure.

- Do not operate with doors open or guards off.
- Stop before servicing.
- Keep away from moving parts.



⚠ WARNING

Dismantling and disposal

- Only a qualified electrician may disconnect the machine or the electrical system
- Before dismantling it the machine must be disconnected from the power supply and from the external compressed air supply
- Before dismantling it, clean the equipment
- The dismantling area must be cleaned afterwards
- During dismantling work, the working area must be adequately ventilated; this can be achieved by provision of a mobile ventilation unit
- During dismantling work, wear appropriate personal protective equipment. We recommend half-face breathing masks to DIN EN 141/143, protection class P3
- The pollutants and dust, together with the dirty filter cartridges, must be properly disposed of in a professional manner in accordance with statutory instructions, using the plastic sack disposal system supplied

⚠ ATTENTION

Maintenance should only be performed by authorized, qualified and trained persons (skilled) using appropriate work practices.



⚠ WARNING

When cleaning equipment or replacing filter use personal protection equipment (PPE) such as gloves, respirators and protective clothing to protect against overexposure to particulate. It is recommended that a vacuum cleaner or wet methods be used to clean up any loose particulate that is present in the extraction arm. It is necessary to use a vacuum cleaner with HEPA rated filtration.



⚠ WARNING

- Observe the maintenance intervals given in this manual. Overdue maintenance can lead to high costs for repair and revisions and can render the guarantee null and void.
- During service, maintenance and repair jobs, always use Personal Protective Equipment (PPE) to avoid injury. This also applies to persons who enter the work area during installation.
- Always use tools, materials, lubricants and service techniques which have been approved by the manufacturer. Never use worn tools and do not leave any tools in or on the product.
- Safety features which have been removed for service, maintenance or repairs, must be put back immediately after finishing these jobs and it must be checked that they still function properly.
- Use sufficient climbing gear and safety guards when working on a higher level than 6 feet.
- Ensure the workspace is well illuminated.

MALFUNCTIONS AND EMERGENCIES EFFECTING THE FILTER UNIT

Fire

- In the event of fire, an approved extinguisher for fire classes A, B and C should be used
- The manufacturer must be contacted.

ESCAPE OF NOXIOUS SUBSTANCES OR RADIATION

- The Prism® 4 contains no noxious substances.
- If the filter ruptures, welding fumes can be released into the building; welding activities must be suspended and the Prism® 4 repaired

PERIODIC MAINTENANCE

The product has been designed to function without problems for many hours with minimal maintenance. In order to ensure this, some simple, regular maintenance and cleaning activities are required which are described in this section. If you observe the necessary caution and carry out the maintenance at regular intervals, any problems that occur will be detected and corrected before they lead to a total breakdown.

The indicated maintenance intervals can vary depending on the specific working and ambient conditions. Therefore it is recommended to thoroughly inspect the complete product once every year other than the indicated periodic maintenance.

The maintenance activities in Table D.1 indicated by [*] can be carried out by the user; other activities are strictly reserved for well trained and authorized service engineers.

TABLE D.1 – PERIODIC MAINTENANCE				
COMPONENT	ACTION	EVERY MONTH	EVERY 3 MONTHS	EVERY 6 MONTHS
Control Panel	Check filters for damage. Take them out of the door of the control panel and clean them with compressed air.	X [*]		
	*Clean inside using an industrial vacuum cleaner.		X	
Drum	*Check levels of dust and dirt particulate. Empty if necessary.	X	X	X
Pre-Filter System (if included)	Inspect and clean or replace pre-filters (some applications may require shorter intervals)	X	X	X

* Frequency depends on welding or cutting process.

MAINTENANCE SCHEDULE

NOTE: * REQUIRES Lincoln Electric factory authorized service technician.

AS NEEDED

- Replace filters (See filter replacement instructions).
- Inspect and test functionality of the filter media cleaning system. *
- Program and verify system performance. *
- Clean spiral ducting. *

MONTHLY

- Check particulate collection drum and dispose of particulate if necessary.
- Check and log filter pressure.
- Check incoming pressure.
- Clean or replace pre-filters.

EVERY 6 MONTHS

- Ensure that the Cubic Feet per Minute (CFM) is operating to the engineered specifications based on the individual system *

UNIT HOUSING

- Clean housing with a non-aggressive detergent.
- Check the connections to the duct work, seal if necessary.
- Inspect and clean (with a non-aggressive detergent) the filter control box.

YEARLY

- Inspect unit for proper operation and function, address any issues found.
- Fan motor temperature is within normal ranges, a hand held IR temp meter is a good tool for this. High motor temps indicate bearing or winding issues and predict a failure. This can also apply to the electrical power connections to the unit- elevated temps on junction boxes and wire terminations are precursors to problems.

MOTOR/FAN HOUSING



Observe safety precautions when working on the inside of the fan box or control panel. Removing power and observing LOTO (Lockout-Tagout) procedures as required.

- Check the integrity of the fan housing and tighten all bolts and screws if necessary.
- Clean housing with a non-aggressive detergent.
- Check connection of silencer to fan housing and seal if necessary.
- Check connection of ductwork to silencer and seal if necessary.

- Check fan motor blades for encrusted particles and clean if necessary.
- Inspect and clean control panel with a non-aggressive detergent.
- Check inlets and outlets for tears or wear.

CONTROL PANEL

- Check for functionality of control panel fan.
- Inspect and clean any buildup or dirt on fan blade impellers in control panel.
- Inspect and replace control panel filters if necessary.

REPLACING FILTER CARTRIDGES OR EMPTYING DUSTBINS

Shut off the compressed air feed and empty the pressure tank(s) of air by opening the drain valve on the bottom of the tank.

NOTE: The power must always be switched off at the circuit-breaker or by the line fuses. Protective gloves and mask should always be worn.

WARNING

Take necessary precautions so that you and your fellow workers are not overexposed to particulate. Wear suitable personal protection equipment, such as gloves, respirator, eye glass and protective clothing when disposing of the filter and particulate.

Check with local waste management or local agency(ies) for assistance in the disposal of filter. If filter has collected certain types of particulate which local agencies define as hazardous waste, filter may be classified as hazardous waste and will need to be disposed in accordance with federal, state and local regulations - which could vary from state to state and between local municipalities within the state.

Use protective gloves. If not carried out with the necessary caution, may cause serious personal injury.

Use breathing protection. If not carried out with the necessary caution, may cause serious personal injury.

- Maintenance work and functional testing should be performed regularly to TRGS 560 section 5, paragraph 9 and to TRGS 528.
- During maintenance the machine must be deenergized and secured against switching on again.
- The maintenance area must be cleaned afterwards.
- During maintenance work the working area must be adequately ventilated; this can be achieved by provision of a mobile ventilation unit.
- During maintenance, appropriate personal protective equipment should be worn. We recommend half-face breathing masks to DIN EN 141/143, protection class P3.
- The dust and the dirty filter cartridges must be properly disposed of in accordance with statutory instructions, using the plastic sack disposal system supplied.

REPLACING FILTER CARTRIDGES

WARNING

Before opening door, unit must be off and the power switch on the side of the control panel turned to the off position.

Verify power has been switched off at the control panel, then unlock door latches using the supplied hex tool or any standard 5/16" hex wrench.

- a. Unclamp handles and lower filters.

FIGURE D.1

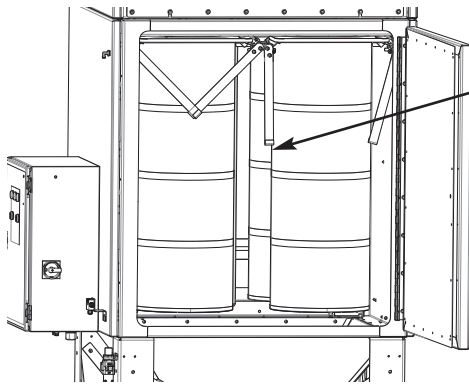

1. Unlock door latches using the supplied hex tool or any 5/16" hex wrench, then open door.
2. Unclasp handles to lower filters for removal

- b. Remove filters.

FIGURE D.2

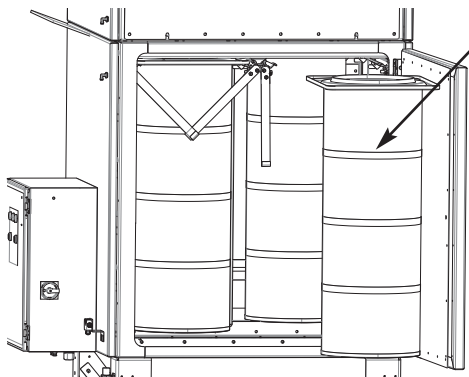

1. Slide filters out of unit through the door opening as shown.
2. If required by federal, state and/or local regulations and guidelines, conceal filter cartridge in appropriate bag, e.g. plastic bag.
3. Dispose of the filter cartridge in accordance with all federal, state and/or local guidelines.
4. Clean the filter compartment with an industrial vacuum cleaner that meets OSHA guidelines for Cr6 house-keeping.

- c. Install new filters.

FIGURE D.3

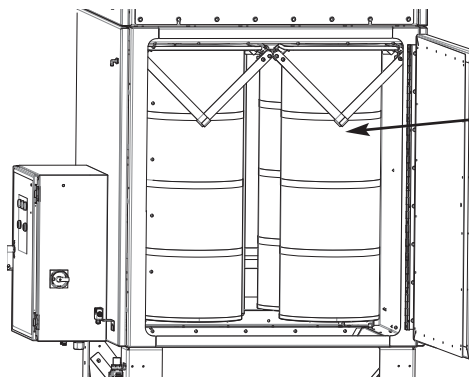

1. Install new filters, making sure they are pushed against rear of unit.
2. Reclasp filter handles to lift filters to their sealed position.
3. Re-lock door latches using the supplied hex wrench or any standard 5/16" hex wrench.

REPLACING PRE-FILTERS

! WARNING

Before removing cover plates, unit must be off and the power switch on the control panel turned to the off position.

Verify power has been switched off at the control panel, then from either side of the unit, remove 16 - 1/4" bolts with a 5/16" nut driver.

- a. Pull off the cover plate.

FIGURE D.4

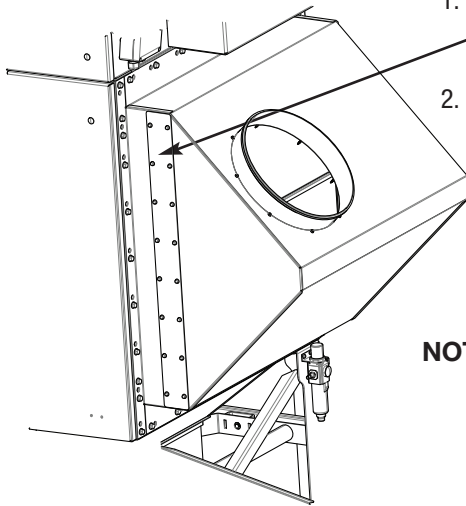

1. Remove the 16 - 1/4" bolts that attach cover plate using a 5/16" nut driver. Set bolts aside for reassembly.
2. Pull cover plate off of the machine frame. Set aside for reassembly.

NOTE: There are 2 pre-filters hooked together. When you pull on the first re-filter, you will also be removing the second pre-filter at the same time (See Illustration Below).

- b. Pull out pre-filter.

FIGURE D.5

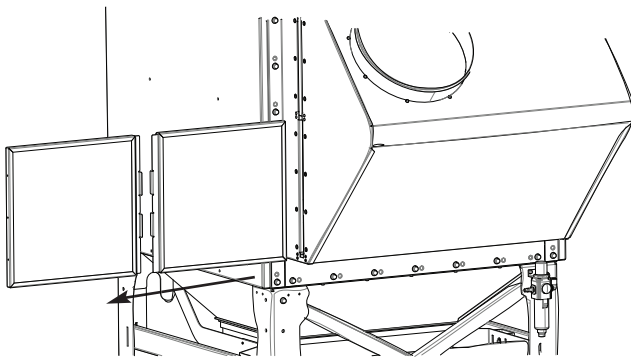

1. Slide pre-filters out of unit through the opening as shown.
2. Once the first pre-filter is completely out of the unit, this will disengage from the second pre-filter.
3. Now finish removing the second pre-filter.
4. Dispose of the pre-filters in accordance with all federal, state and/or local guidelines.

- c. Install new filters.

FIGURE D.6

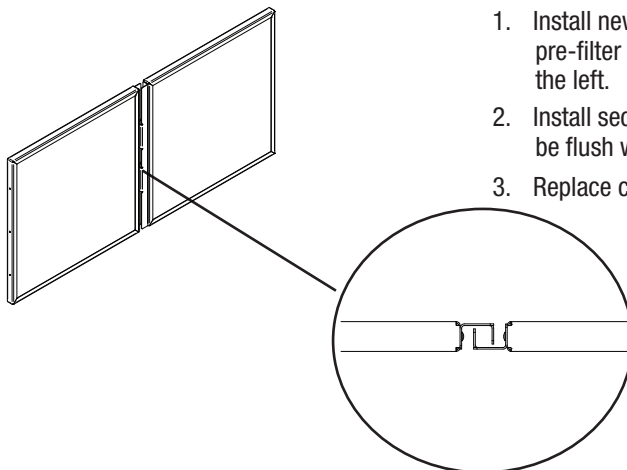

1. Install new pre-filter approximately three fourths into the unit. Take second pre-filter and interlock brackets. Make sure the interlock looks as shown to the left.
2. Install second pre-filter by pushing on both pre-filters. The pre-filter should be flush with unit when fully installed.
3. Replace cover panel with the 16 - 1/4" bolts.

TROUBLESHOOTING GUIDE



Service and Repair should only be performed by Lincoln Electric Factory Trained Personnel. Unauthorized repairs performed on this equipment may result in danger to the technician and machine operator and will invalidate your factory warranty. For your safety and to avoid ELECTRICAL SHOCK, please observe all safety notes and precautions detailed throughout this manual.

This Troubleshooting Guide is provided to help you locate and repair possible machine malfunctions. Simply follow the three-step procedure listed below.

Step 1. LOCATE PROBLEM (SYMPTOM).

Look under the column labeled “PROBLEM (SYMPTOMS)”. This column describes possible symptoms that the machine may exhibit. Find the listing that best describes the symptom that the machine is exhibiting.

Step 2. POSSIBLE CAUSE(S).

The second column labeled “POSSIBLE AREA(S) OF MISADJUSTMENTS” lists the obvious external possibilities that may contribute to the machine symptom.

Step 3. RECOMMENDED COURSE OF ACTION

This column provides a course of action for the Possible Areas of Misadjustment(s).

Service and Technical Support

For information about specific adjustments, maintenance or repair jobs which are not dealt with in this manual, please contact Lincoln Electric Automation Department 888-935-3878.

Make sure you have the following data on hand:

- product name
- serial number
- purchase order (number + date) for warranty verification



If for any reason you do not understand the test procedures or are unable to perform the tests/repairs safely, contact your Lincoln Authorized Service Facility for technical troubleshooting assistance before you proceed.

WWW.LINCOLNELECTRIC.COM/LOCATOR

Observe all Safety Guidelines detailed throughout this manual

Observe all Safety Guidelines detailed throughout this manual		
PROBLEMS (SYMPTOMS)	POSSIBLE CAUSE	RECOMMENDED COURSE OF ACTION
FUNCTION PROBLEMS		
White Power On light does not light up.	<ol style="list-style-type: none"> 1. Main Switch is in off position 2. No power supply 3. Fuse(s) defective 	Turn on main switch <ol style="list-style-type: none"> 1. Check power supply. 2. Check for normal component operation. 3. Are green power lights illuminated on PLCs and components? If not, replace. 4. If any components replaced were Smartwire, the green LED will be flashing and the "Learn" process has to be done before the component(s) are recognized, and the unit will operate
Cleaning cycle is not functioning.	<ol style="list-style-type: none"> 1. Possible bad connection between control box and junction box. 2. Possible bad electrical connection. 3. Possibly no or low compressed air. 	<ol style="list-style-type: none"> 1. Verify that the Fan running LED (Green) and the white power on light is illuminated. A green LED comes on on the Eaton 4DD I/O pack when the output comes on, a flash should be seen as the valve is pulsed on to create the air blast during an active cleaning cycle. 2. Verify the correct input voltage is being applied. 3. Verify that all fuses and circuit breakers are not blown/tripped. 4. Verify that the LED's on the Eaton Smartwire I/O pack are illuminated, on solid green is good, flashing means the IO pack has power but is not recognized by the system. Find the "learn" smartwire function reference in the manual. During a cleaning an output LED flashes on for the I/O pack, it sends a 24VDC pulse to the air valve. Check the cable connection from the valve to the I/O pack, to confirm a working valve or I/O port swap cables on outputs. 5. Verify compressed air is present and with adequate pressure.
Cleaning valve fails to open.	<ol style="list-style-type: none"> 1. The pulsation cycle may be faulty. 2. Possible dirt in the housing of the valve. 3. Possible incorrect flow direction on the cleaning valves. 4. Possible incorrect control voltage for the magnetic valves. 	<ol style="list-style-type: none"> 1. Verify that the pulsation cycle is OK, that it's within the parameters recommended by Lincoln Electric. 2. Clean the housing of the valve. 3. Verify that the airflow directions on the cleaning valves are in accordance with the airflow. 4. Verify that the cleaning system is working properly - 87 PSI (6 BAR) 5. Verify that control voltage for the magnetic valve is 24V DC and connected at the Eaton SWD4-SFL8-12 flat to round cable converter at terminals X2-24V and X2-0V. This power is what goes out to the 4DD IO packs to activate the valves..
Cleaning valve fails to close.	<ol style="list-style-type: none"> 1. The pulsation cycle may be faulty. 2. Possible dirt in the housing of the valve. 3. Possible incorrect control voltage for the magnetic valves. 	<ol style="list-style-type: none"> 1. Verify that the pulsation cycle is OK, that it's within the parameters recommended by Lincoln Electric. 2. Clean the housing of the valve. 3. Verify that the cleaning system is working properly - 87 PSI (6 BAR) 4. Verify that control voltage for the magnetic valve is 0 Volts.



If for any reason you do not understand the test procedures or are unable to perform the tests/repairs safely, contact your Lincoln Authorized Service Facility for technical troubleshooting assistance before you proceed.

WWW.LINCOLNELECTRIC.COM/LOCATOR

Observe all Safety Guidelines detailed throughout this manual

Observe all Safety Guidelines detailed throughout this manual		
PROBLEMS (SYMPTOMS)	POSSIBLE CAUSE	RECOMMENDED COURSE OF ACTION
FUNCTION PROBLEMS		
Filter replacement alarm does not function.	<ol style="list-style-type: none"> 1. Pre-filters are clogged. 2. Wrong DP reading reported by sensor. 3. Incorrect duct air velocity. 	<ol style="list-style-type: none"> 1. Clean or replace pre-filters 2. The Differential Pressure sensor PD1 is read by PLC1, after confirming solid electrical and tubing connections you can tap into the readings with a "T" fitting with a hand held manometer to confirm its readout matches the real DP. Calibrate or re-zero the sensor if needed, change it if it doesn't operate properly. 3. Verify the duct air velocity is not too low. Measure and adjust as necessary.
The air flow is diminished.	<ol style="list-style-type: none"> 1. Pre-filters are clogged. 2. Cartridge filters are clogged. 3. Fan speed control issue. 	<ol style="list-style-type: none"> 1. Clean or replace pre-filters 2. Replace cartridge filters. 3. Make sure your duct pressure sensor PD2 is giving a proper reading into the PLC1. Fan speed is controlled via this input feeding into a PID control loop. 4. If all recommended possible areas of misadjustment have been checked and the problem persists, Contact your local Lincoln Authorized Field Service Facility. 1-888-935-3878.
Particulate is emitting from the collection drum.	<ol style="list-style-type: none"> 1. Collection drum is full. 2. Possible bad seal and clamp on the collection drum. 	<ol style="list-style-type: none"> 1. Empty the collection drum. 2. Calibrate or re-zero the duct pressure sensor, if the output is still bad change the duct pressure sensor. 3. If all recommended possible areas of misadjustment have been checked and the problem persists, Contact your local Lincoln Authorized Field Service Facility. 1-888-935-3878.
There is an abnormal amount of weld fume in the work zone.	<ol style="list-style-type: none"> 1. Check to make sure the machine is powered on. 2. Check nozzle position. 3. Have an electrician check fan speed on VFD. 4. Make sure your duct pressure sensor PD2 is giving a proper reading into the PLC1. Fan speed is controlled via this input feeding into a PID control loop. 5. Check for clogged or torn filters 	<ol style="list-style-type: none"> 1. Calibrate or re-zero the duct pressure sensor, if the output is still bad change the duct pressure sensor. 2. If all recommended possible areas of misadjustment have been checked and the problem persists, Contact your local Lincoln Authorized Field Service Facility. 1-888-935-3878. 3. Replace filters.



If for any reason you do not understand the test procedures or are unable to perform the tests/repairs safely, contact your Lincoln Authorized Service Facility for technical troubleshooting assistance before you proceed.

WWW.LINCOLNELECTRIC.COM/LOCATOR

Observe all Safety Guidelines detailed throughout this manual

Observe all Safety Guidelines detailed throughout this manual		
PROBLEMS (SYMPTOMS)	POSSIBLE CAUSE	RECOMMENDED COURSE OF ACTION
FUNCTION PROBLEMS		
Poor suction.	<ol style="list-style-type: none"> 1. Outlet(s) are blocked. 2. Pre-filters and/or cartridge filters are clogged. 	<ol style="list-style-type: none"> 1. Clean or replace pre-filters and/or replace cartridge filters. 2. If all recommended possible areas of misadjustment have been checked and the problem persists, Contact your local Lincoln Authorized Field Service Facility. 1-888-935-3878.
Dust or smoke coming out of the outlet opening(s). Pollution of the facility.	<ol style="list-style-type: none"> 1. Filter cartridge is damaged. 2. Sealing on filter cartridge is damaged. 	<ol style="list-style-type: none"> 1. Replace the filter cartridge.
Dust or smoke coming out of the inlet opening(s). Pollution of the facility.	<ol style="list-style-type: none"> 1. Outlets blocked. 2. Filter cartridge clogged. 3. Non-- return valve(s) installed incorrectly. 	<ol style="list-style-type: none"> 1. Remove obstructions from the outlet opening(s) and/or connected ductwork. 2. Replace filter cartridge. 3. Install non-return valve(s) correctly.
Alarm - Red Alarm LED lights.	<ol style="list-style-type: none"> 1. Red alarm light is on solid if controls know there is a fault with the VSS. 2. Red alarm light is flashing if the DP alarm set point is reached. 	<ol style="list-style-type: none"> 1. Press alarm reset and investigate VSS fault issue. Note the VSS red LED flashing fault code to help determine reason for the fault. 2. If the Differential Pressure read by the sensor is higher than your DP Alarm set point your alarm light will be on and flashing and the unit most likely has already passed your online cleaning set point (default of which is 1500 Pa). Filters need to be changed if this DP reading is correct and your set point is realistic.
Fan does not start running	<p>No power</p> <p>Variable Speed Starter DE 1 has red fault light on or shows no lights at all.</p> <p>Motor defective</p> <p>Controller defective</p>	<p>Check Fuse FU1, FU2, and FU3 for incoming power to the drive and FU4, FU5 and FU6 for the controls power and replace if necessary.</p> <p>Remove and re-apply AC line voltage to the unit after a 1 minute delay. Variable Speed Starter (VSS) will reset for some faults. If this cycle repeats locate the source of fault- checking motor, wiring and each connection point to motor and the VSS. Replace VSS if determined to be faulty.</p> <p>After checking for proper 24VDC supply to devices. They should each have a green power "POW" light on. Determine normal lights seen on an operating unit if possible and compare to the faulty controls for hints on what component isn't operating correctly. Replace suspected component(s).</p>



If for any reason you do not understand the test procedures or are unable to perform the tests/repairs safely, contact your Lincoln Authorized Service Facility for technical troubleshooting assistance before you proceed.

WWW.LINCOLNELECTRIC.COM/LOCATOR

AD1326-18, AD1326-19, AD1326-21, AD1326-22, AD1326-31, AD1326-32, AD1326-33, AD1326-34, AD1326-35 Schematic - M28172 (1 of 2)



A07
M28172PRINT
Sheet 1 of 2

THE LINCOLN ELECTRIC COMPANY
World's Leader in Welding and Cutting Products
Sales and Service through Subsidiaries and Distributors Worldwide
Cleveland, Ohio 44117-1199 U.S.A.



- NOTES:
 N.A. USE UL RATED 18AWG 300V MIN 105°C COPPER LEADS UNLESS SPECIFIED
 N.B. USE CLASS-1 CONDUCTORS FOR FIELD WIRING
 N.C. 12 AWG / 14 AWG LEADS SHALL BE 600V MIN, 105°C UL RATED COPPER CONDUCTOR
 N.D. LONG SHORT DOTTED LINES INDICATE OUTSIDE THE CONTROL PANEL
 N.E. D1 FC 101 VFD BUS TERMINATION TURNED ON

DISCONNECTING MEANS AND BRANCH CIRCUIT PROTECTION SHALL BE PROVIDED BY THE INSTALLER

AD1326-18, AD1326-19, AD1326-21, AD1326-22, AD1326-31, AD1326-32, AD1326-33, AD1326-34, AD1326-35 Schematic - M28172 (2 of 2)

4 BANK

ITEM#	REF	DESCRIPTION	QTY
1	CB1	CABLE ASSEMBLY 0.6M	1
2	CB2	CABLE MT12.5C DOUBLE ENDED 2M	1
3	CB3	CABLE ASSEMBLY 20M	1
4	1DD	SMARTWIRE DT1/O 2X DIGITAL	1
5	2DD	SMARTWIRE DT1/O 4X DIGITAL	1
6	SP1-SP2	SMART SPLIT MODULE	2
7	CB4	CABLE ASSEMBLY SINGLE END	4

VALVE WIRING		
SPLITTER PIN#	COLOR	FUNCTION
2	WHITE (WH)	O0/O1
3	BLUE (BL)	0V GND

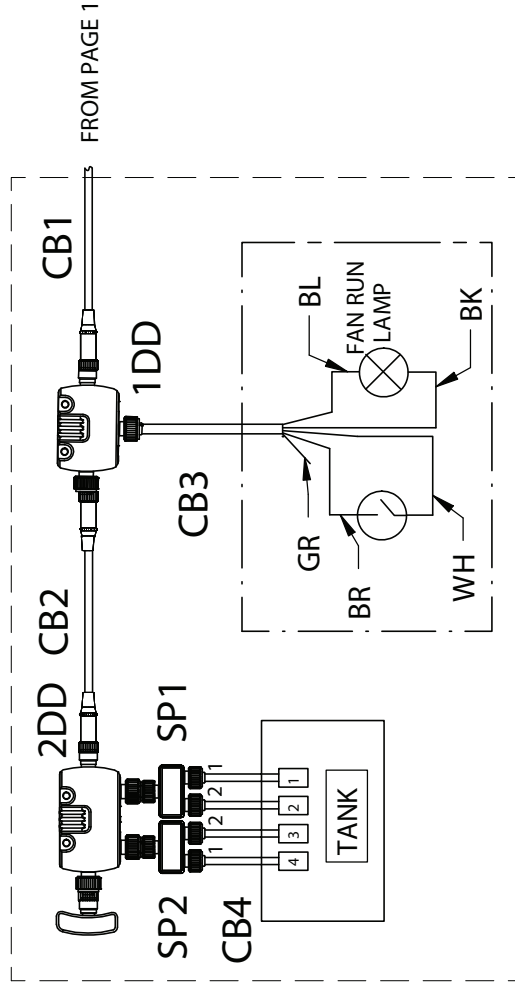

ROBOTIC CELL START/STOP		
PIN#	COLOR	FUNCTION
1	BROWN (BN)	+24VDC
2	WHITE (WH)	I/O Ch2(1)
3	BLUE (BL)	0V GND
4	BLACK(BK)	I/O Ch1(0)
5	GRAY(GR)	N/C



THE LINCOLN ELECTRIC COMPANY
 World's Leader in Welding and Cutting Products
 Sales and Service through Subsidiaries and Distributors Worldwide
 Cleveland, Ohio 44117-1199 U.S.A.

A.07
 M28172PRINT
 Sheet 2 of 2

AD1326-18, AD1326-19, AD1326-31, AD1326-33, Schematic - M28475 (1 of 3)

CONTROL PANEL: L18648

ITEM	DESCRIPTION	QTY
1	CONTROL PANEL HMI 10HP	4 BANK
2	PRESSURE SENSOR	1
3	CABLE ASSEMBLY	1
4	SMART WIRE DT I/O 2X DIGITAL	1
5	CABLE ASSEMBLY	1
6	SMART WIRE DT I/O 4X DIGITAL	1
7	DT BUS TERMINATION MODULE	1
8	CABLE ASSEMBLY	1
9	24VDC SOLENOID	4
10	CABLE MALE M12 5C SINGLE ENDED 2M	4
11	SMART WIRE SPLIT DEVICE	2
12	MOTOR CABLE FORMED	1
13	3C 20AWG CABLE FORMED	1
14	ROBOTIC START/STOP SIMULATOR	1
15	IF15	1
16	ROBOT INTERFACE ISOLATION RELAY KIT	*

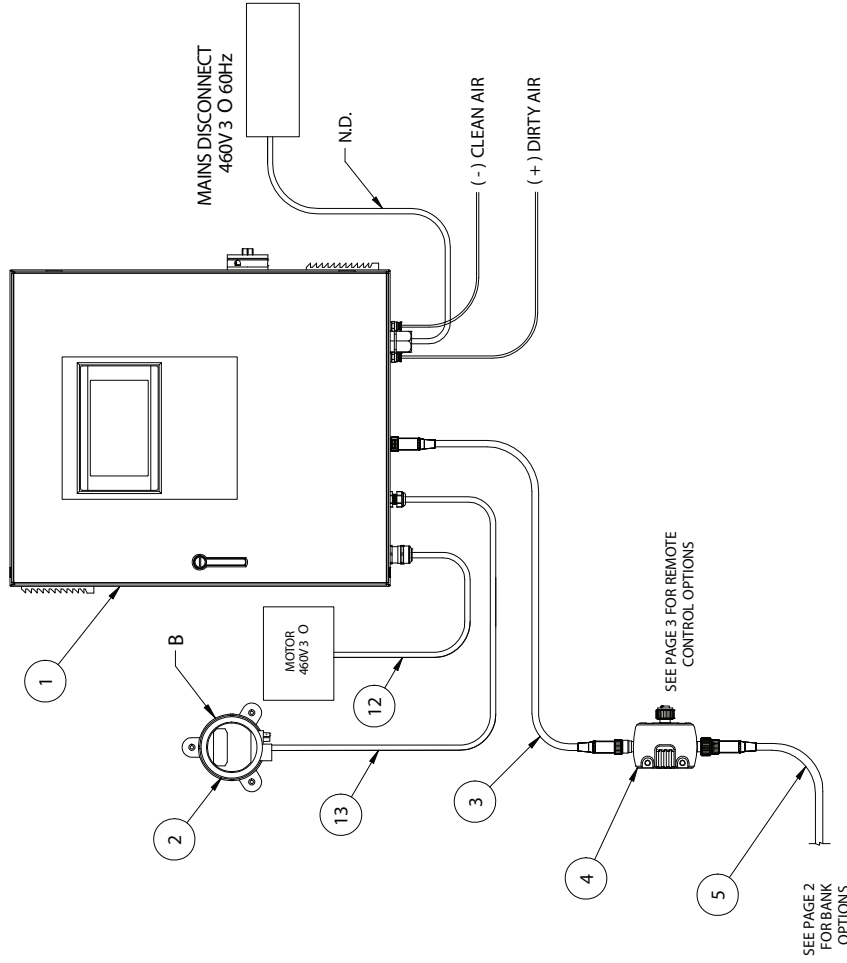

NOTES:
 N.A. LOCATED ON UNIT
 N.B. DRY CONTACT BETWEEN 1 & 2 IS UNIT REMOTE START. UNIT WILL OUTPUT A HIGH (24VDC) ON 4 REFERENCED TO
 3 IF UNIT IS ON AND READY FOR ACTIVE FUME EXTRACTION
 N.C. TURN ON 1,6,7 AND 8. REMAINING TO OFF TO CONFIGURE THE PRESSURE SENSOR
 N.D. ITEM 8 SHALL BE CUT AT FEMALE END AND CONNECT TO THE ROBOT I/O AS SHOWN.
 N.E. N/C IS NOT CONNECTED

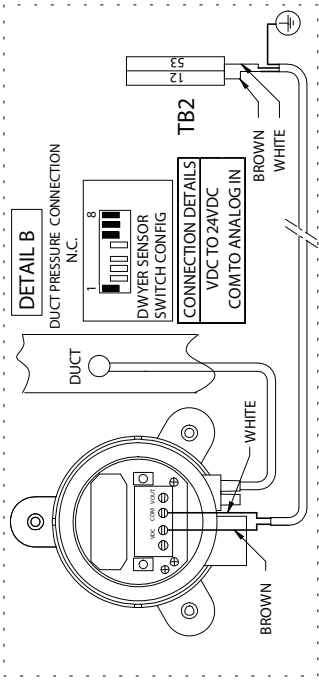

THE LINCOLN ELECTRIC COMPANY
 World Headquarters: Cleveland, Ohio 44117-1199 U.S.A.
 Sales and Service through Subsidiaries and Distributors Worldwide

A03
 M28475PRINT
 Sheet 1 of 3

STAPLE ALL PAGES TOGETHER

AD1326-18, AD1326-19, AD1326-31, AD1326-33, Schematic - M28475 (2 of 3)

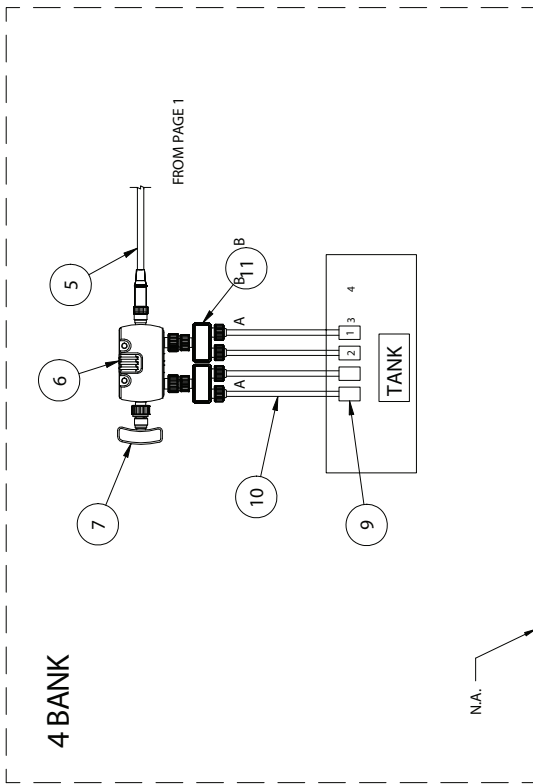

VALVE WIRING		
SPLITTER PIN#	COLOR	FUNCTION
2	WHITE (WH)	00/01
3	BLUE (BL)	0V GND

LINCOLN
ELECTRIC

THE LINCOLN ELECTRIC COMPANY
 World's Leader in Welding and Cutting Products
 Sales and Service Centers in Over 100 Countries Worldwide
 Cleveland, Ohio 44117-1199, U.S.A.

STAPLE ALL PAGES TOGETHER

A.03
 M28475PRINT
 Sheet 2 of 3

AD1326-18, AD1326-19, AD1326-31, AD1326-33, Schematic - M28475 (3 of 3)

ITEM 8 SIGNAL DETAILS		
PIN	COLOR	FUNCTION
1	BROWN (BR)	+24V DC
2	WHITE (WH)	I/O Ch2 (1)
3	BLUE (BL)	DV GND
4	BLACK (BK)	I/O Ch1 (0)
5	GRAY	N/C

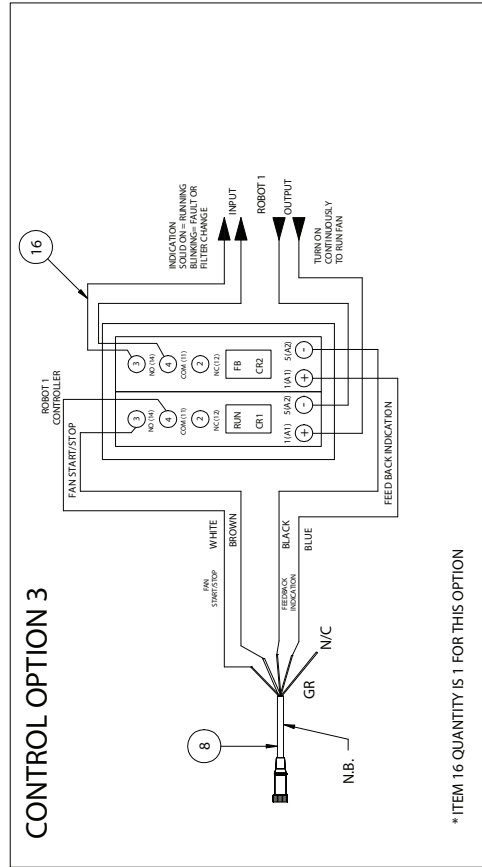
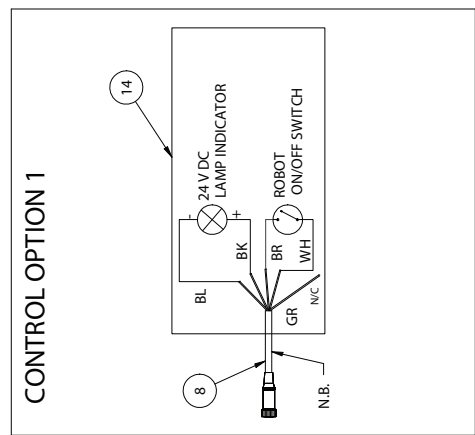
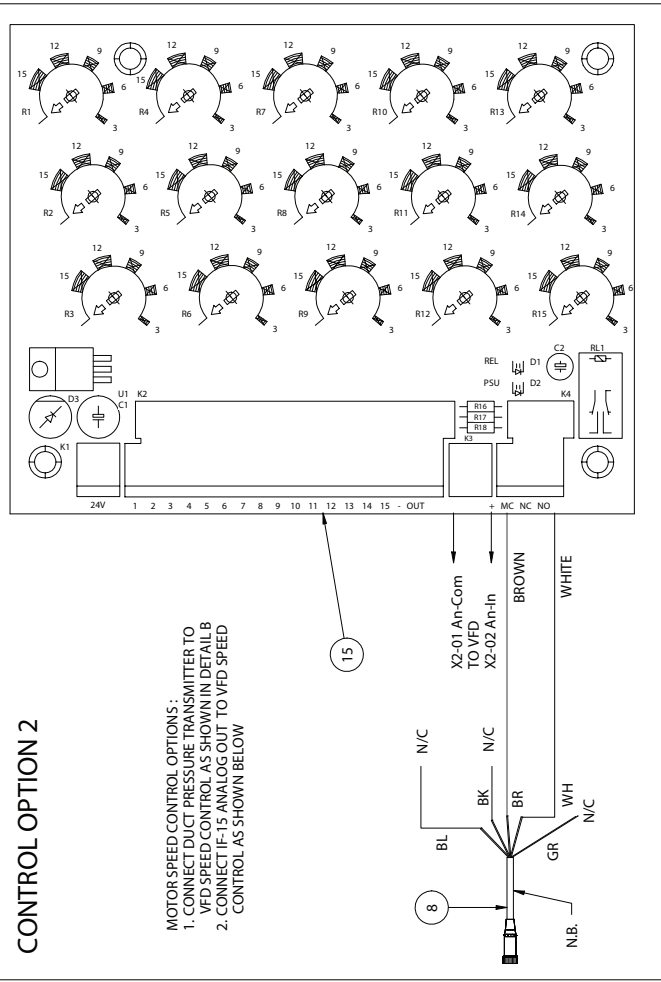
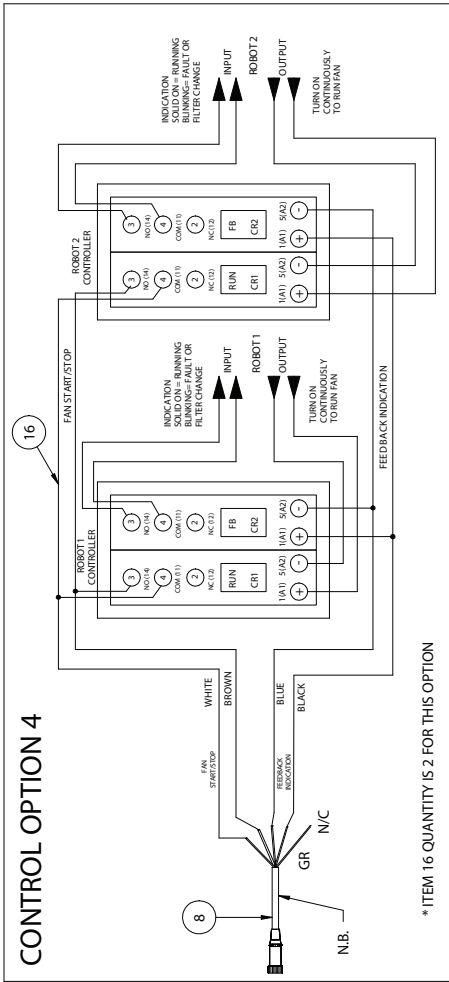

LINCOLN ELECTRIC
 THE LINCOLN ELECTRIC COMPANY
 World's Leader in Welding and Cutting Products
 Sales and Service Centers in 100 Countries Worldwide
 Cleveland, Ohio 44117-1199, U.S.A.

A03
 M28475PRINT
 Sheet 3 of 3

STAPLE ALL PAGES TOGETHER

AD1326-17, AD1326-20, AD1326-27, AD1326-28, AD1326-29, AD1326-30, Schematic - M28189 (2 of 2)

4 BANK

ITEM#	REF	DESCRIPTION	QTY
1	CB1	CABLE ASSEMBLY 0.6M	1
2	CB2	CABLE ASSEMBLY 3M	2
3	CB3	CABLE ASSEMBLY 20M	1
4	1DD	SMARTWIRE DT I/O 2X DIGITAL	1
5	2DD	SMARTWIRE DT I/O 4X DIGITAL	1
6	SP1-SP2	SMART SPLIT MODULE	2
7	CB4	CABLE ASSEMBLY SINGLE END	4

VALVE WIRING	
SPLITTER PIN#	FUNCTION
2	WHITE (WH) O0/O1
3	BLUE (BL) 0V GND

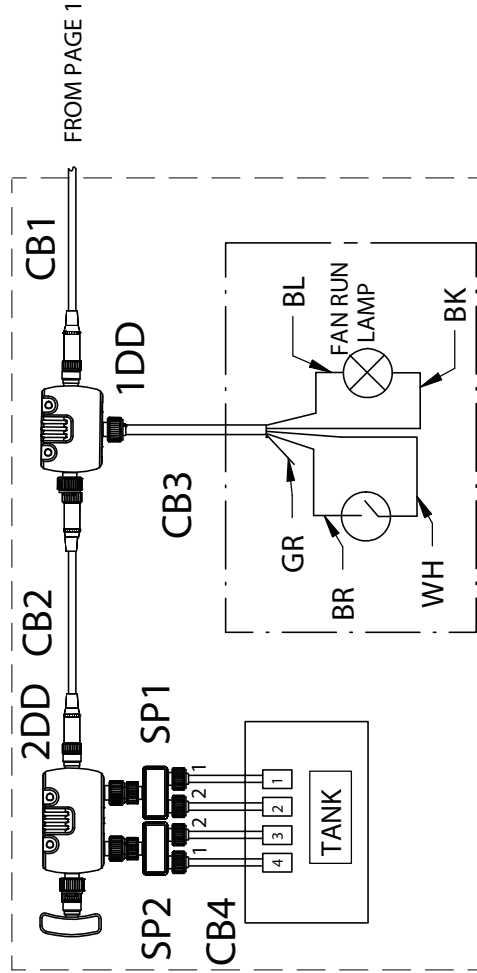

ROBOTIC CELL START/STOP		
PIN#	COLOR	FUNCTION
1	BROWN (BN)	+24VDC
2	WHITE (WH)	I/O Ch2(1)
3	BLUE (BL)	0V GND
4	BLACK(BK)	I/O Ch1(0)
5	GRAY(GR)	N/C



THE LINCOLN ELECTRIC COMPANY
 World's Leader in Welding and Cutting Products
 Sales and Service through Subsidiaries and Distributors Worldwide
 Cleveland, Ohio 44117-1199 U.S.A.

A.04
 M28189PRINT
 Sheet 2 of 2

AD1326-17, AD1326-27, AD1326-29 Schematic - M28477 (1 of 3)

ITEM	DESCRIPTION	BANK DETAILS
1	CONTROL PANEL HMI 5 HP	4
2	PRESSURE SENSOR	1
3	CABLE ASSEMBLY	1
4	SMART WIRE DT I/O 2X DIGITAL	1
5	CABLE ASSEMBLY	1
6	SMART WIRE DT I/O 4X DIGITAL	1
7	DT BUS TERMINATION MODULE	1
8	24VDC SOLENOID	4
9	CABLE MALE M12 5C SINGLE ENDED 2M	4
10	SMART WIRE SPLIT DEVICE	2
11	MOTOR CABLE FORMED	1
12	3C 20AWG CABLE FORMED	1
13	CABLE ASSEMBLY 20M	N.D.
14	ROBOTIC START/STOP SIMULATOR	1
15	ROBOT INTERFACE ISOLATION RELAY KIT	#
16	IF15	1

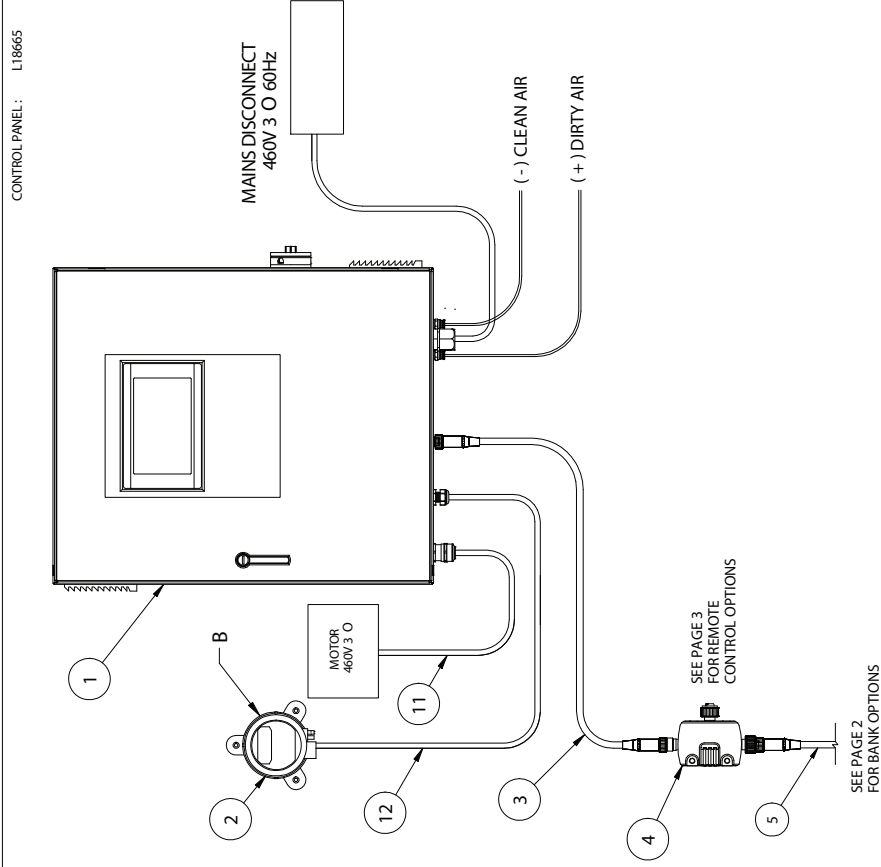

NOTES:
 N.A. TURN ON 1,6,7 AND 8, REMAINING TO OFF TO CONFIGURE THE PRESSURE SENSOR.
 N.B. N/C IS NOT CONNECTED.
 N.C. DRY CONTACT BETWEEN 1 & 2 IS UNIT REMOTE START. UNIT WILL OUTPUT A HIGH (24VDC) ON 4 REFERENCED TO 3. IF UNIT IS ON AND READY FOR ACTIVE FUME EXTRACTION.
 N.D. ITEM 14 SHALL BE CUT AT FEMALE END AND CONNECT TO THE ROBOT I/O AS SHOWN.
 N.E. LOCATED ON UNIT.

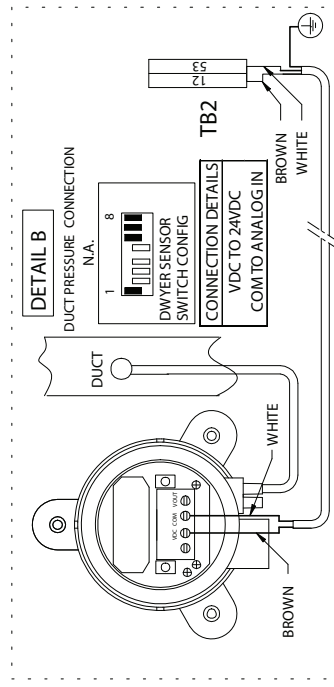

THE LINCOLN ELECTRIC COMPANY
 World's Leader in Welding and Cutting Products.
 Sales and Service through Subsidiaries and Distributors Worldwide
 Cleveland, Ohio 44117-1199, U.S.A.

A.03
 M28477/PRINT
 Sheet 1 of 3

AD1326-17, AD1326-27, AD1326-29 Schematic - M28477 (2 of 3)

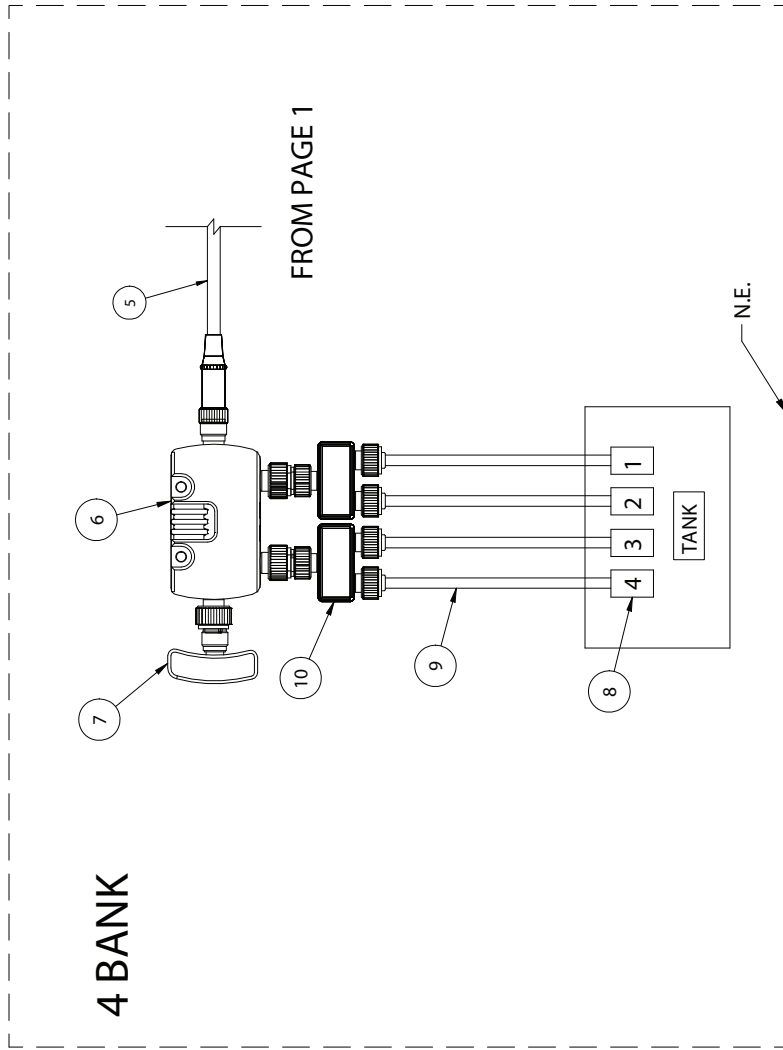

VALVE WIRING		
SPLITTER PIN#	COLOR	FUNCTION
2	WHITE (WH)	00/01
3	BLUE (BL)	0V/GND

THE LINCOLN ELECTRIC COMPANY
 World's Leader in Welding and Cutting Products
 Sales and Service through Subsidiaries and Distributors Worldwide
 Cleveland, Ohio 44117-1199 U.S.A.



A03
 M28477PRINT
 Sheet 2 of 3

AD1326-17, AD1326-27, AD1326-29 Schematic - M28477 (3 of 3)

ITEM 14 SIGNAL DETAILS	
PIN	FUNCTION
1	BROWN (BR) +24V DC
2	WHITE (WH) I/O CR2 (1)
3	BLUE (BL) 0V/GND
4	BLACK (BK) I/O Ch1 (0)
5	GRAY (GY) N/C

ITEM 13 CONNECTS TO ITEM 4 IN PAGE 1

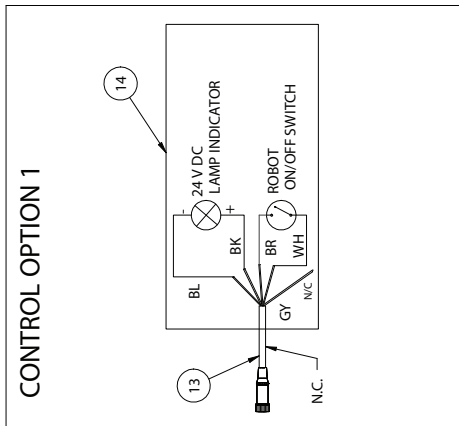

CONTROL OPTION 4

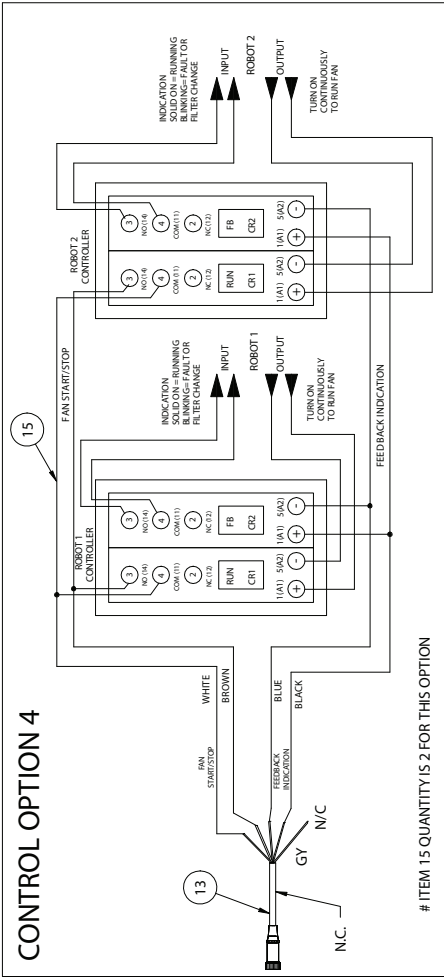

ITEM 15 QUANTITY IS 2 FOR THIS OPTION

CONTROL OPTION 2

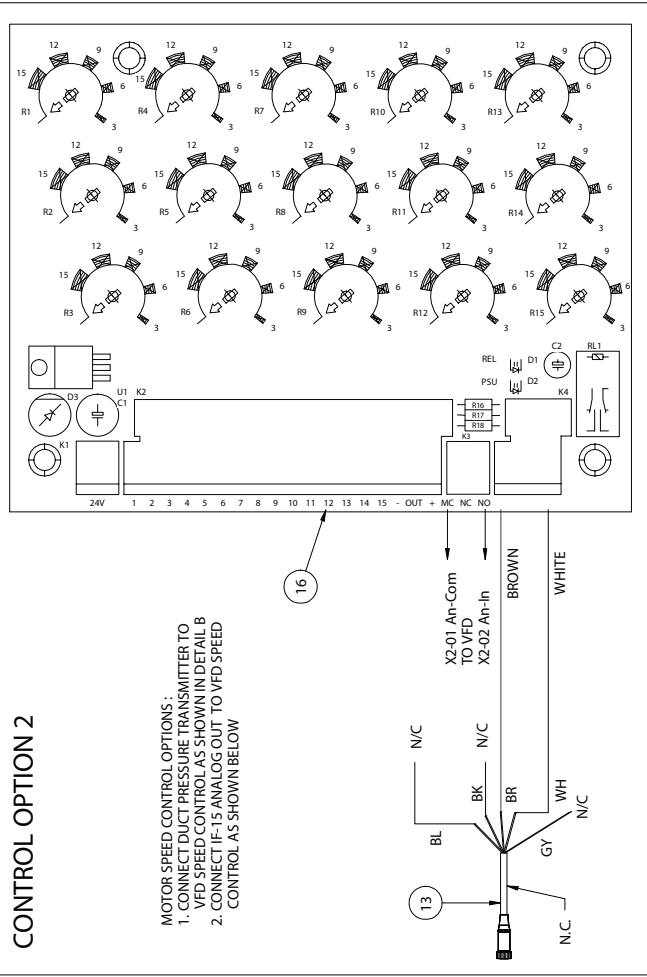

MOTOR SPEED CONTROL OPTIONS:
 1. CONNECT DUCT PRESSURE TRANSMITTER TO VFD SPEED CONTROL AS SHOWN IN DETAIL B
 2. CONNECT IF-15 ANALOG OUT TO VFD SPEED CONTROL AS SHOWN BELOW

CONTROL OPTION 3

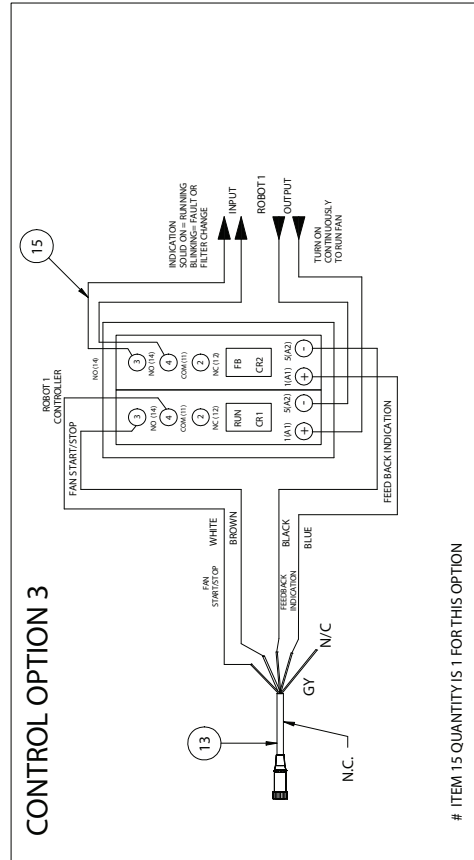

ITEM 15 QUANTITY IS 1 FOR THIS OPTION

THE LINCOLN ELECTRIC COMPANY
 Worlds Leader in Welding and Cutting Products
 Sales and Service Centers in 100 Countries Worldwide
 Cleveland, Ohio 44117-2199, U.S.A.



AD1326-20, AD1326-21, AD1326-22, AD1326-28, AD1326-30, AD1326-32, AD1326-34, AD1326-35 Schematic - M28476 (1 of 4)

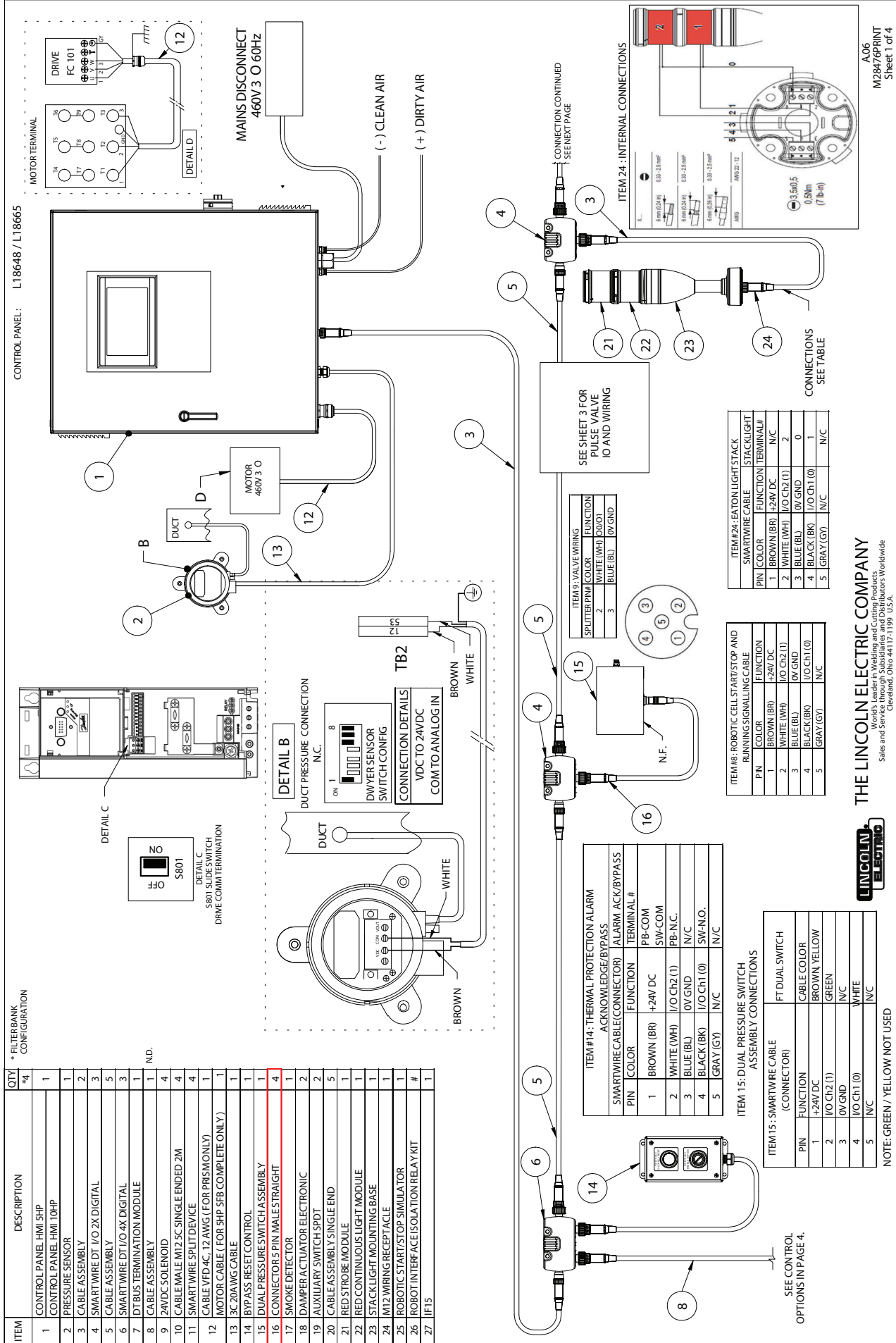

THE LINCOLN ELECTRIC COMPANY
World's Leader in Welding and Cutting Products
Lincoln Electric Company, Inc.
Cleveland, Ohio 44117-1199, U.S.A.
Sales and Service Offices Worldwide



A06
M28476/PRINT
Sheet 1 of 4

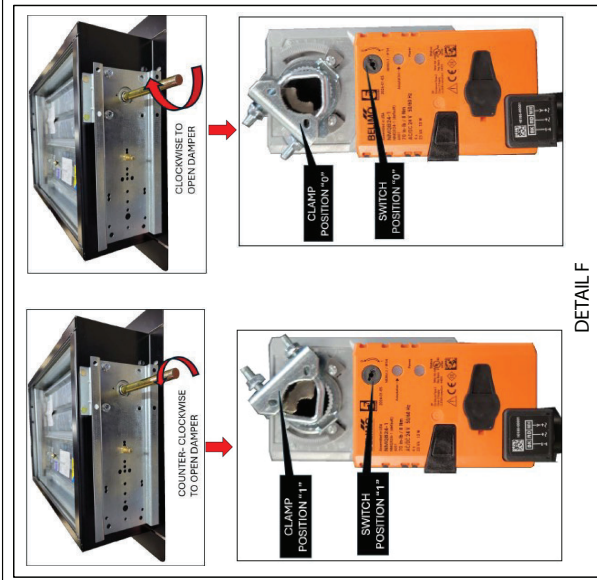

DETAIL F

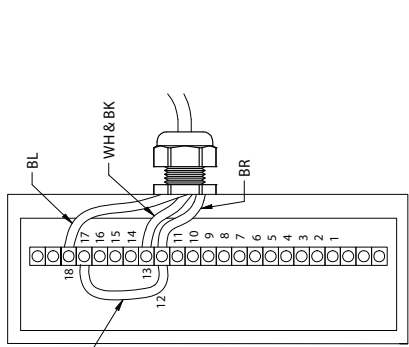

DETAIL E

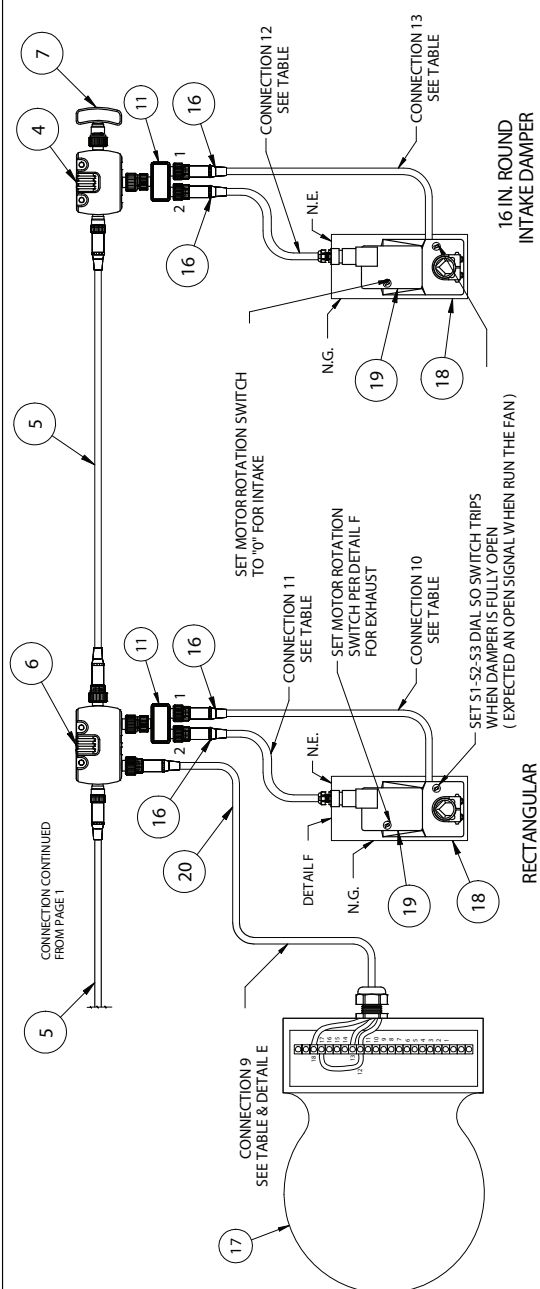

DAMPER - CONNECTIONS 10 & 13

SMARTWIRE CABLE (CONNECTOR)	BELIMO SWITCH
PIN	CABLE COLOR
1	BROWN (BR) +24V DC
2	WHITE (WH) I/O Ch2 (1)
3	BLUE (BL) 0V GND
4	BLACK (BK) I/O Ch1 (0)
5	GRAY (GY) N/C

CONNECTIONS 11 & 12

SMARTWIRE CABLE (CONNECTOR)	BELIMO MOTOR
PIN	CABLE COLOR
1	BROWN (BR) +24V DC
2	WHITE (WH) I/O Ch2 (1)
3	BLUE (BL) 0V GND
4	BLACK (BK) I/O Ch1 (0)
5	GRAY (GY) N/C

ITEM #17: SMOKE ALARM - CONNECTION 9

SMARTWIRE CABLE	SMOKE ALARM	
PIN	FUNCTION	TERMINAL.#
1	BROWN (BR) +24V DC	17 & 12
2	WHITE (WH) I/O Ch2 (1)	13
3	BLUE (BL) 0V GND	18
4	BLACK (BK) I/O Ch1 (0)	13
5	GRAY (GY) N/C	N/C

ITEM 15: FT DUAL PRESSURE SWITCH CIRCUIT SHOWN AT ATMOSPHERIC PRESSURE

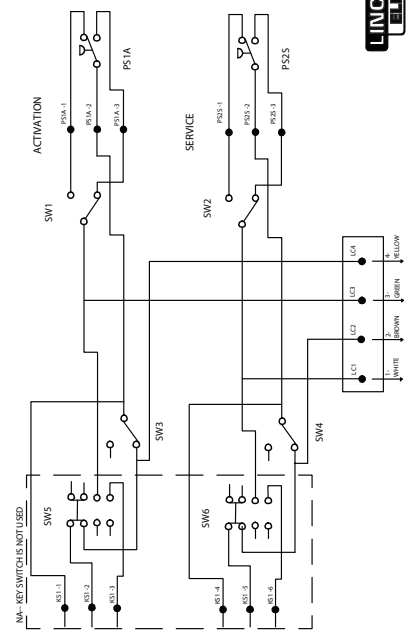

NOTES:
 N.A. N/C IS NOT CONNECTED
 N.B. DRY CONTACT BETWEEN 1 & 2 IS UNIT REMOTE START. UNIT WILL OUTPUT A HIGH (24VDC) ON 4 REFERENCED TO 3 IF UNIT IS ON AND READY FOR ACTIVE FLUME EXTRACTION
 N.C. TURN ON 1, 6, 7 AND 8, REMAINING TO OFF TO CONFIGURE THE PRESSURE SENSOR.
 N.D. ITEM 8 SHALL BE CUT AT FEMALE END AND CONNECT TO THE ROBOT I/O AS SHOWN.
 N.E. TRIM CABLE LENGTHS TO GIVE A LOOP FROM DAMPER TO IO MODULE. COVER WITH BLACK SHEATH USED ON SMARTWIRE GREEN CABLES.
 N.F. TO MATCH SWITCH CONFIGURATION SHOWN ON SYSTEM WIRING PRINT SET SLIDE SWITCHES SW1 UP, SW2 UP, SW3 DOWN, SW4 DOWN, SW5 AND SW6 ARE NOT USED.
 N.G. REFER TO DETAIL F //536794 FOR SETTING THE DAMPER DIRECTION.

THE LINCOLN ELECTRIC COMPANY

World's Leader in Welding and Cutting Products
 Sales and Service through Subsidiaries and Distributors Worldwide
 Cleveland, Ohio 44117-1199 U.S.A.



AD1326-20, AD1326-21, AD1326-22, AD1326-28, AD1326-30, AD1326-32, AD1326-34, AD1326-35 Schematic - M28476 (3 of 4)

4 BANK

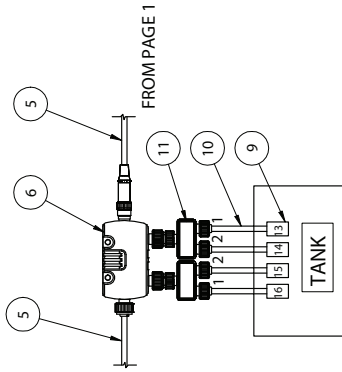

VALVE WIRING		
SPLITTER PIN#	COLOR	FUNCTION
2	WHITE (WH)	00/O1
3	BLUE (BL)	0V GND

VFD WIRING FOR ITEM #1		PARAMETERS TO SET IN VFD	
PARAMETER	DESCRIPTION	PARAMETER	VALUE
HMI CONTROL PANEL RS485-3	VFD SIGNAL +	8-30	[2] MODBUS RTU
RS485-7	-	8-31	ADDRESS 2
		8-32	BAUD RATE [4] 38400 BAUD
		8-33	PARITY / STOP BITS [0] EVEN PARITY, 1 STOP BIT
		8-35	MINIMUM RESPONSE DELAY 0.010S
		8-36	MAXIMUM RESPONSE DELAY 5.000S
		8-37	MAXIMUM INTER-CHAR DELAY 0.025S
		20-93	P1 PROPORTIONAL GAIN 1.50
		20-94	P1 INTEGRAL TIME 15.00S

TURN SWITCH S801 TO THE "ON" POSITION FOR TERMINATION ON VFD

AD1326-20, AD1326-21, AD1326-22, AD1326-28, AD1326-30, AD1326-32, AD1326-34, AD1326-35 Schematic - M28476 (4 of 4)

ITEM 8 SIGNAL DETAILS		
PN	COLOR	FUNCTION
1	BROWN (BR)	+24V DC
2	WHITE (WH)	I/O Ch.2 (I)
3	BLUE (BL)	0V GND
4	BLACK (BK)	I/O Ch.1 (O)
5	GRAY (GY)	N/C

ITEM 8 CONNECTS TO ITEM 6 IN PAGE 1

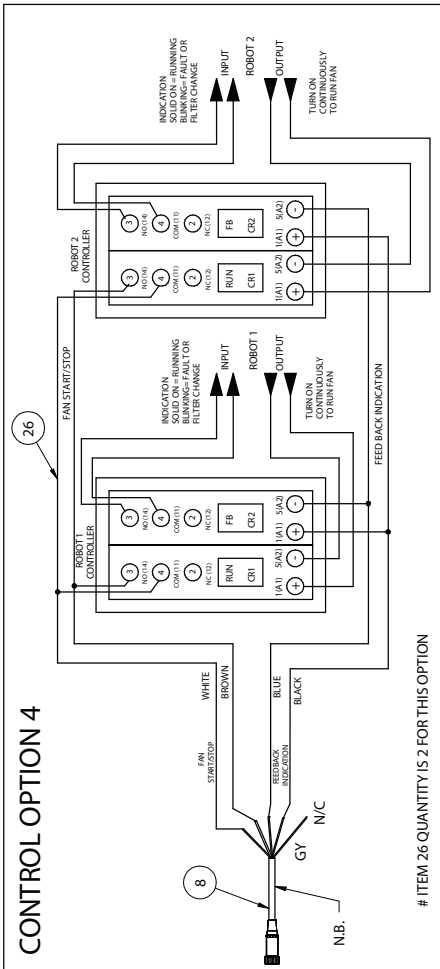
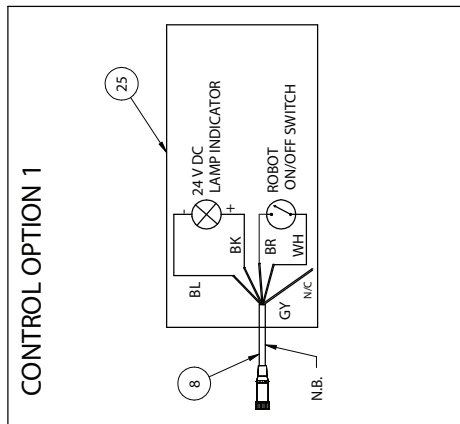

ITEM 26 QUANTITY IS 2 FOR THIS OPTION

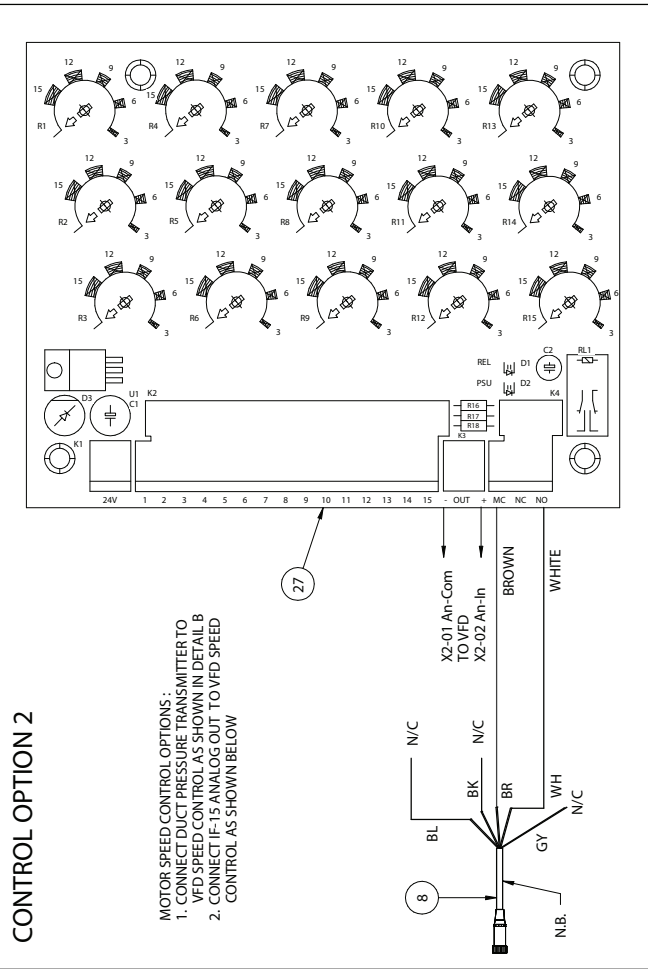

MOTOR SPEED CONTROL OPTIONS:
 1. CONNECT DUCT PRESSURE TRANSMITTER TO VFD SPEED CONTROL AS SHOWN IN DETAIL B
 2. CONNECT IF-15 ANALOG OUT TO VFD SPEED CONTROL AS SHOWN BELOW

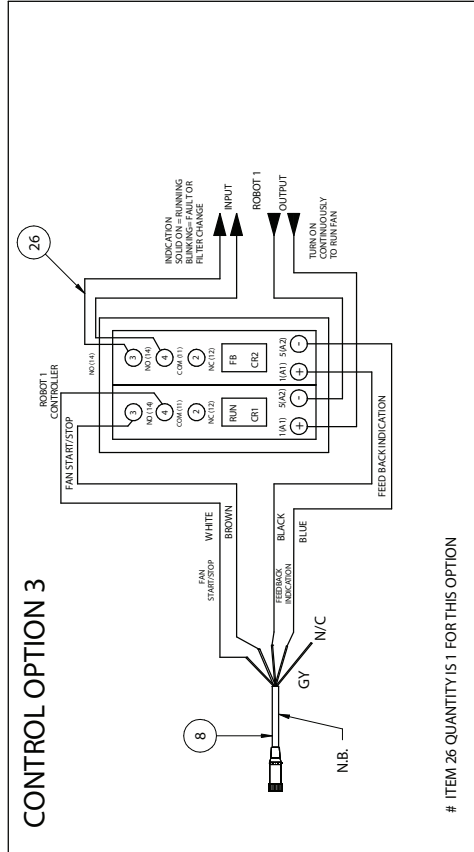

ITEM 26 QUANTITY IS 1 FOR THIS OPTION

THE LINCOLN ELECTRIC COMPANY
 World's Leader in Welding and Cutting Products
 Sales and Service Centers in 100+ Countries Worldwide
 Cleveland, Ohio 44117-1199, U.S.A.



A.06
 M28476PRINT
 Sheet 4 of 4

AD1326-17 & AD1326-20

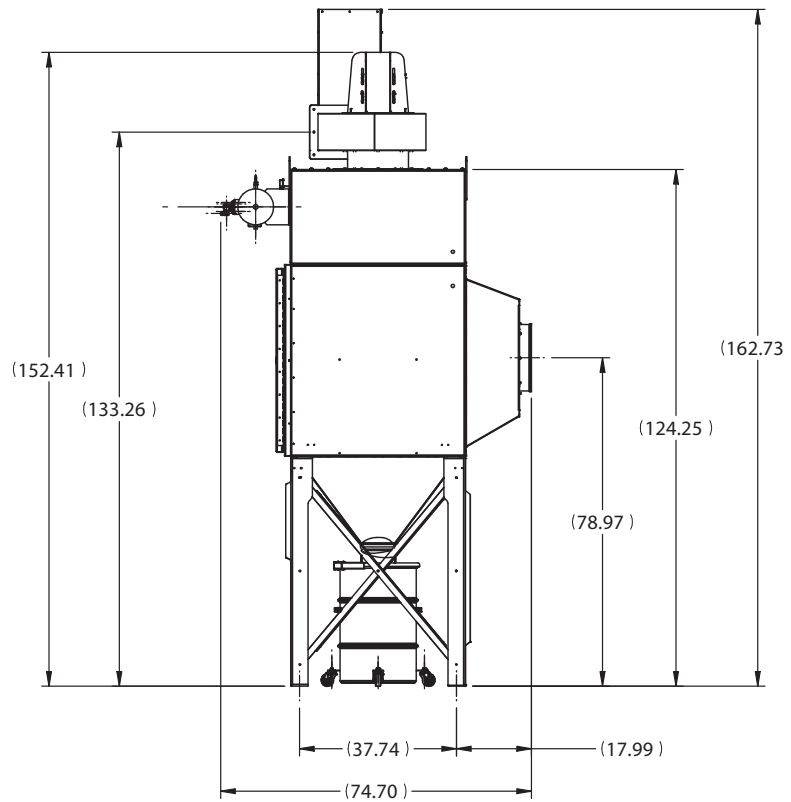
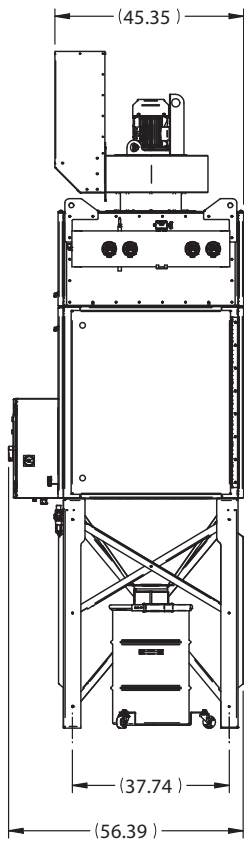
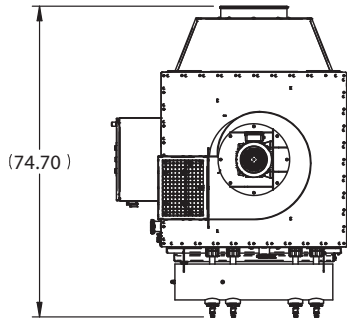

AD1326-18 & AD1326-21

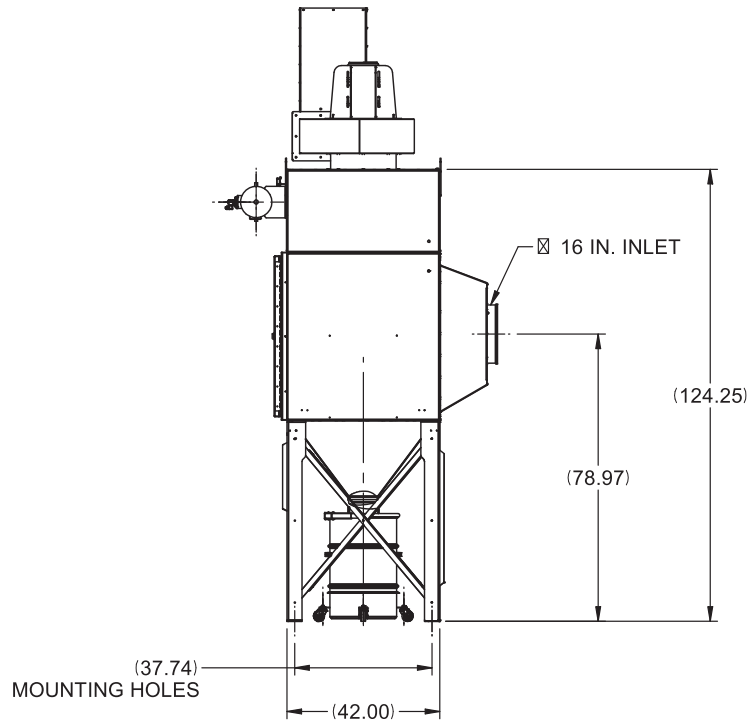
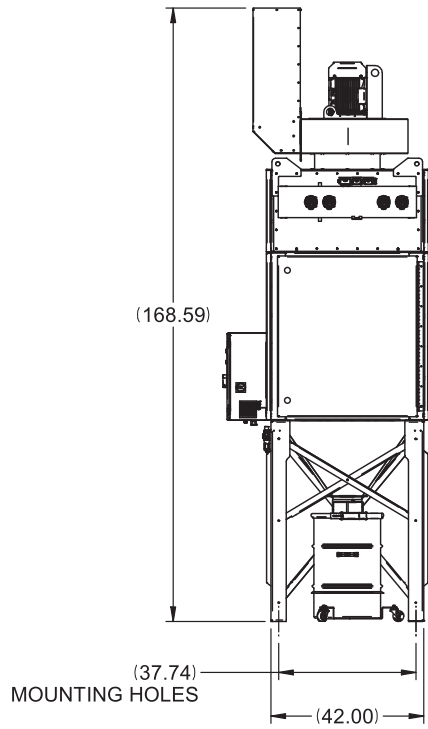
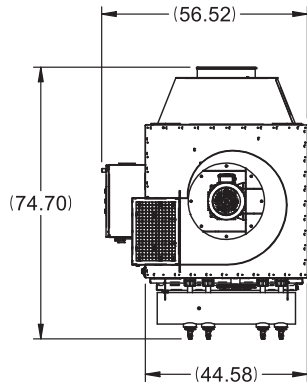

AD1326-19 & AD1326-22

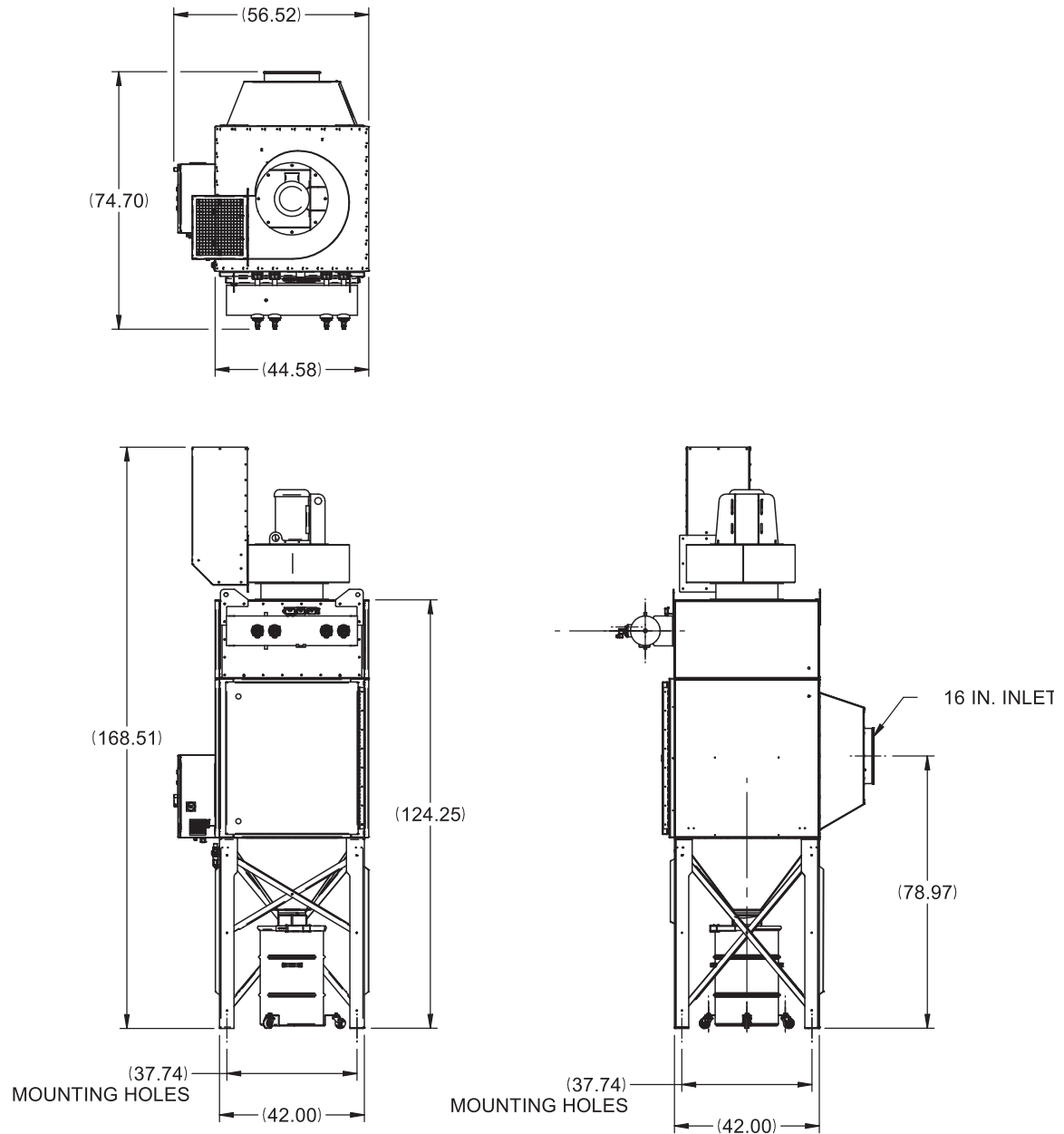

AD1326-27

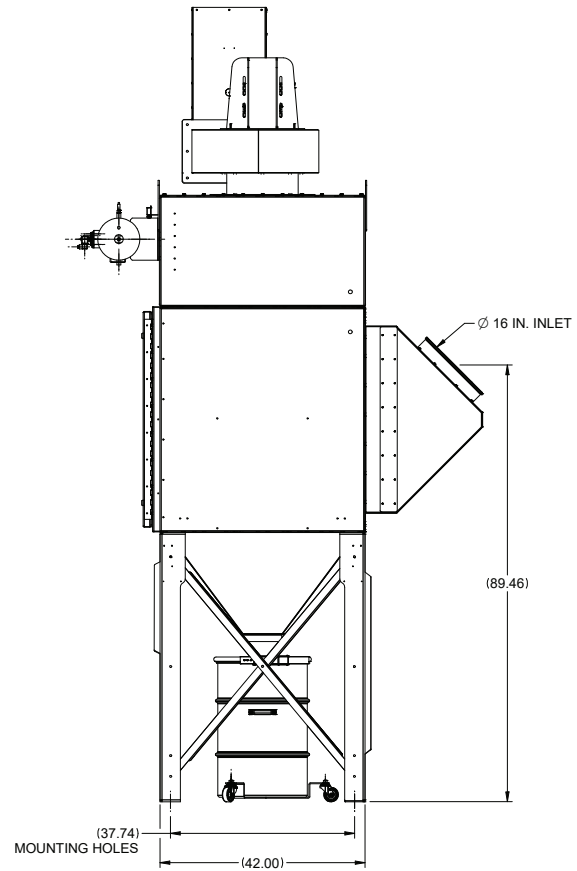
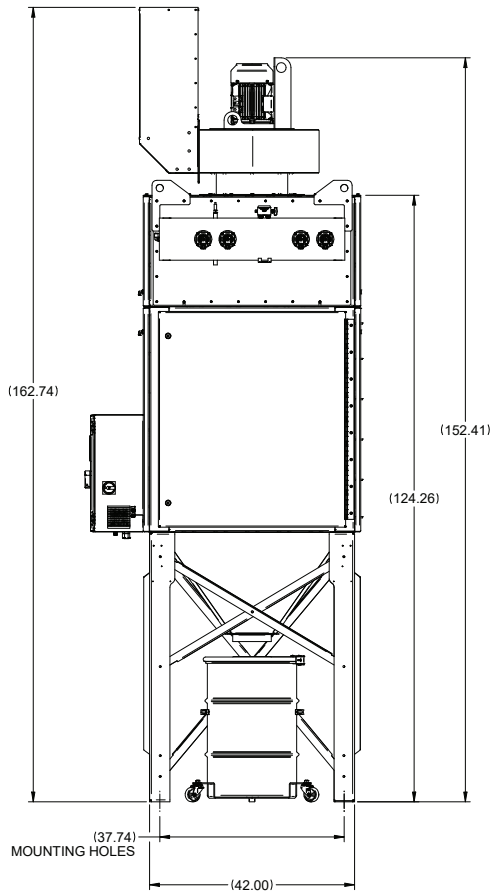
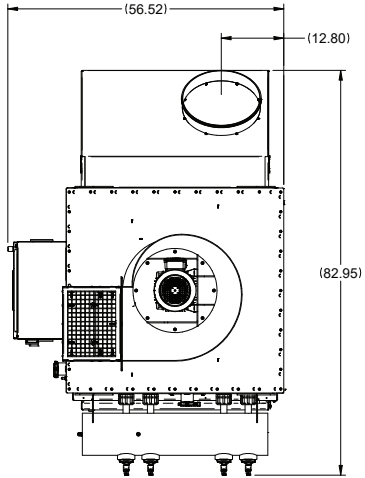

SCALE 1:20

AD1326-28

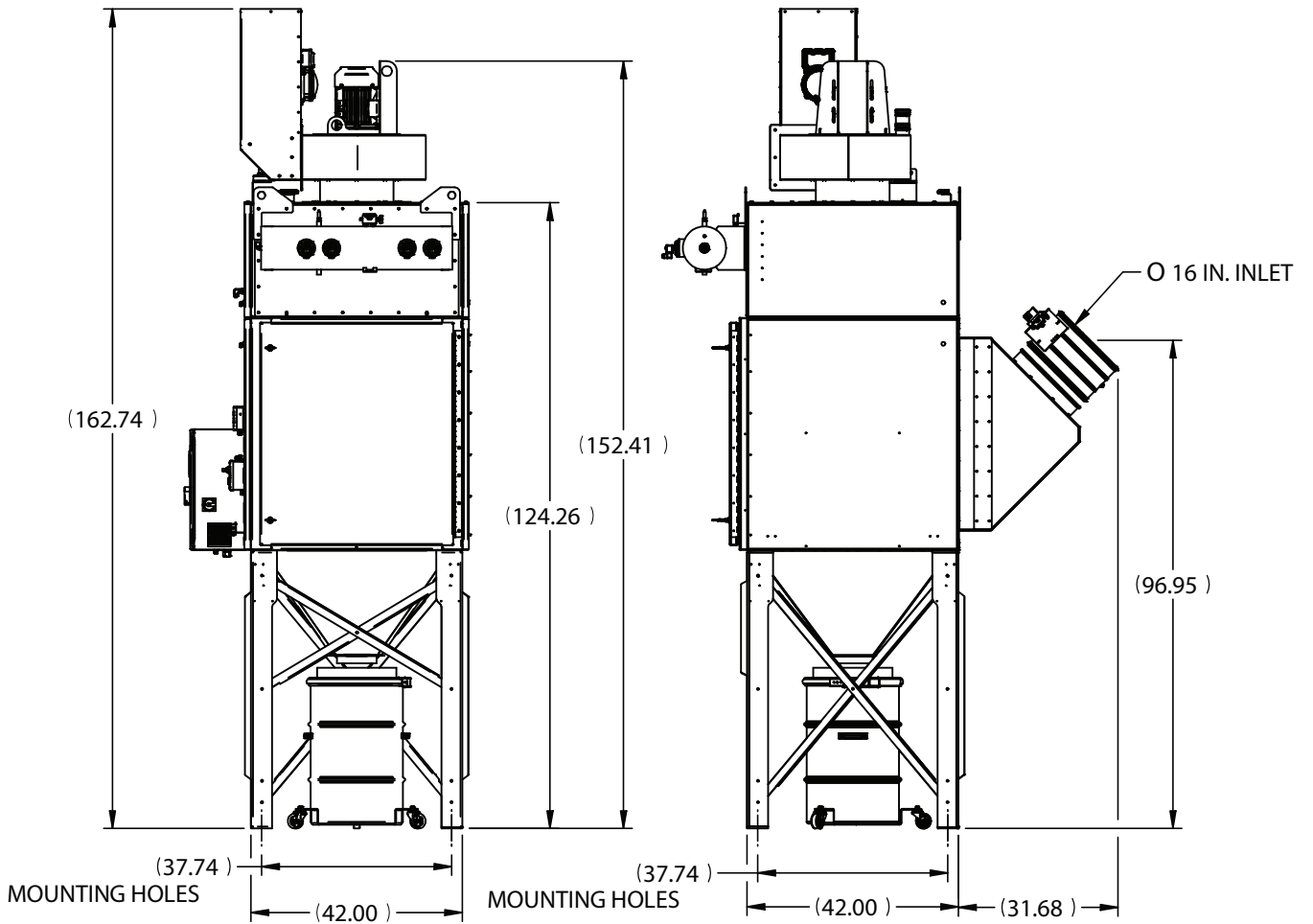
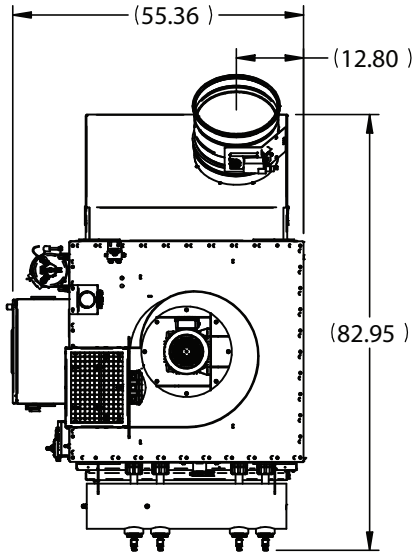

AD1326-29

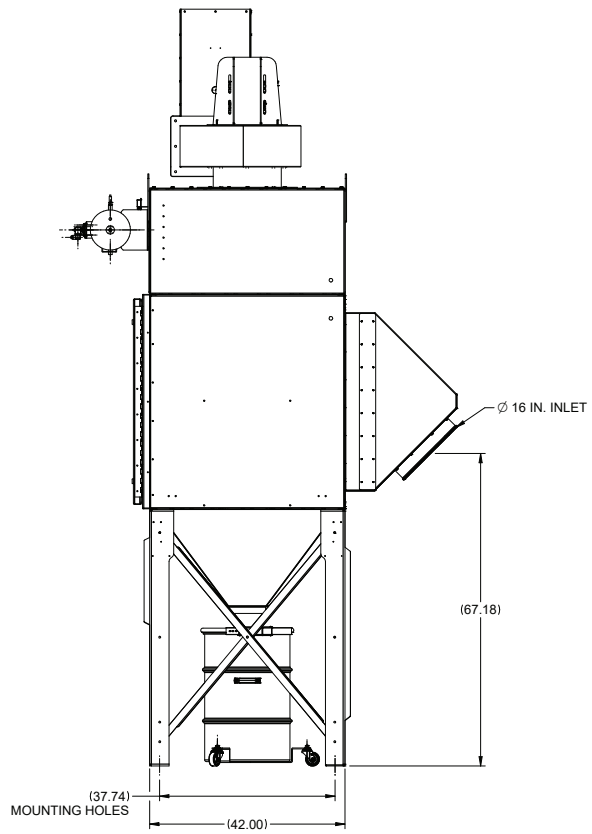
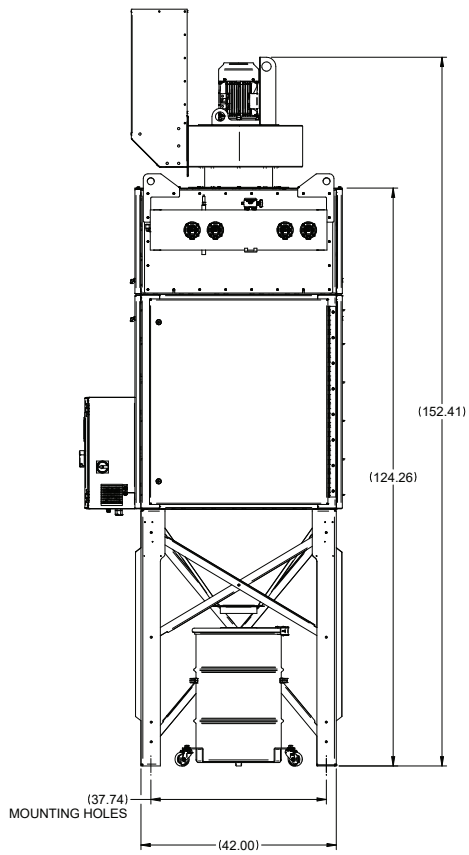
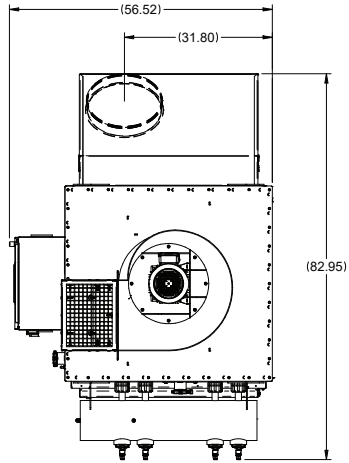

AD1326-30

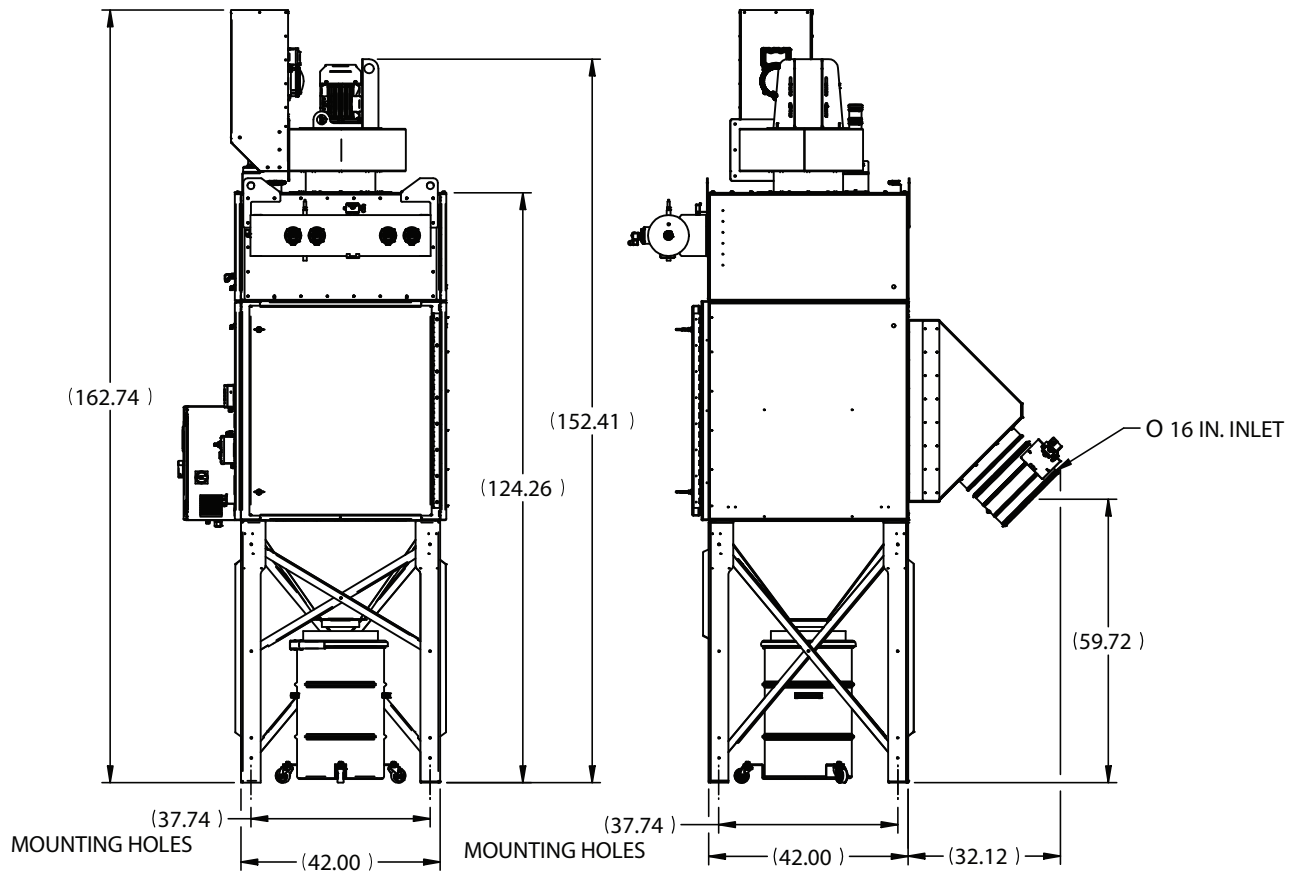
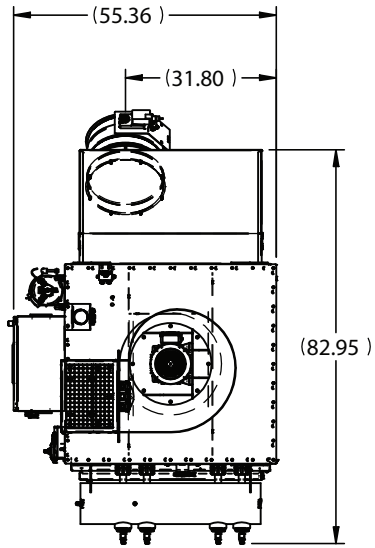

AD1326-31

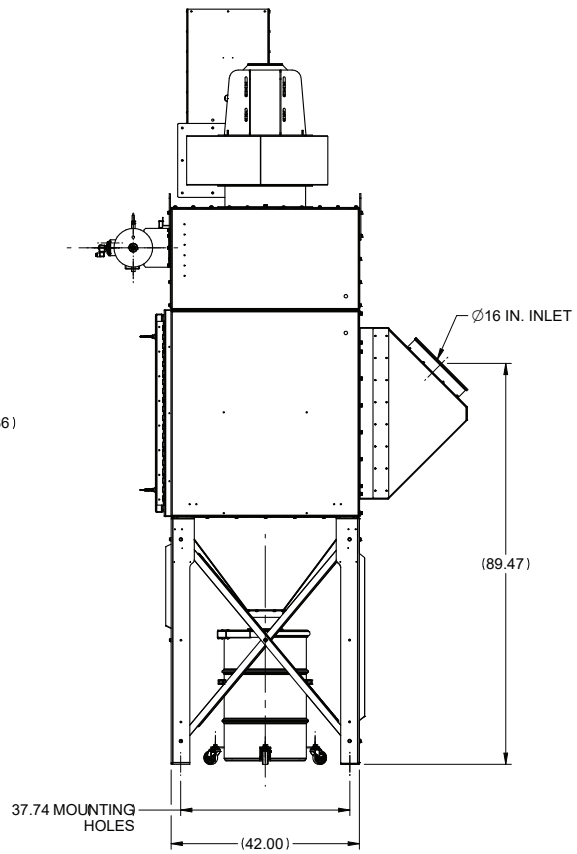
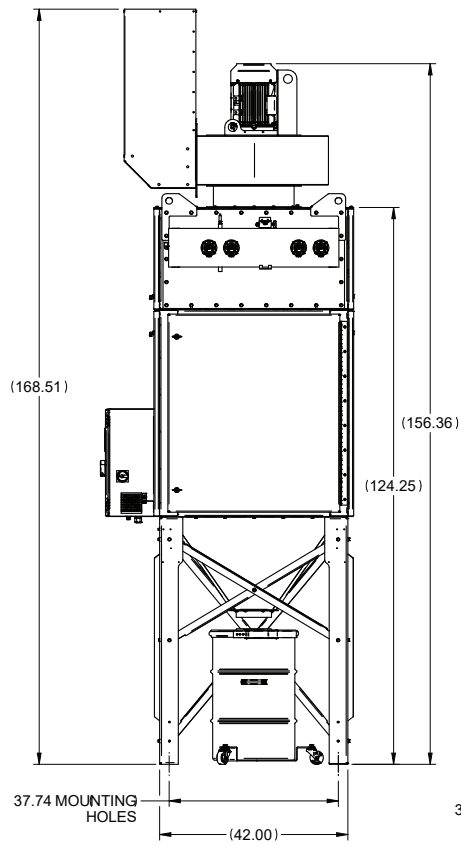
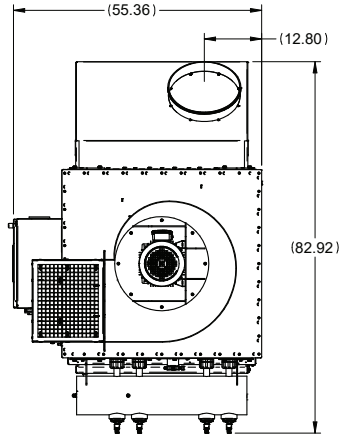

AD1326-32 & AD1326-35

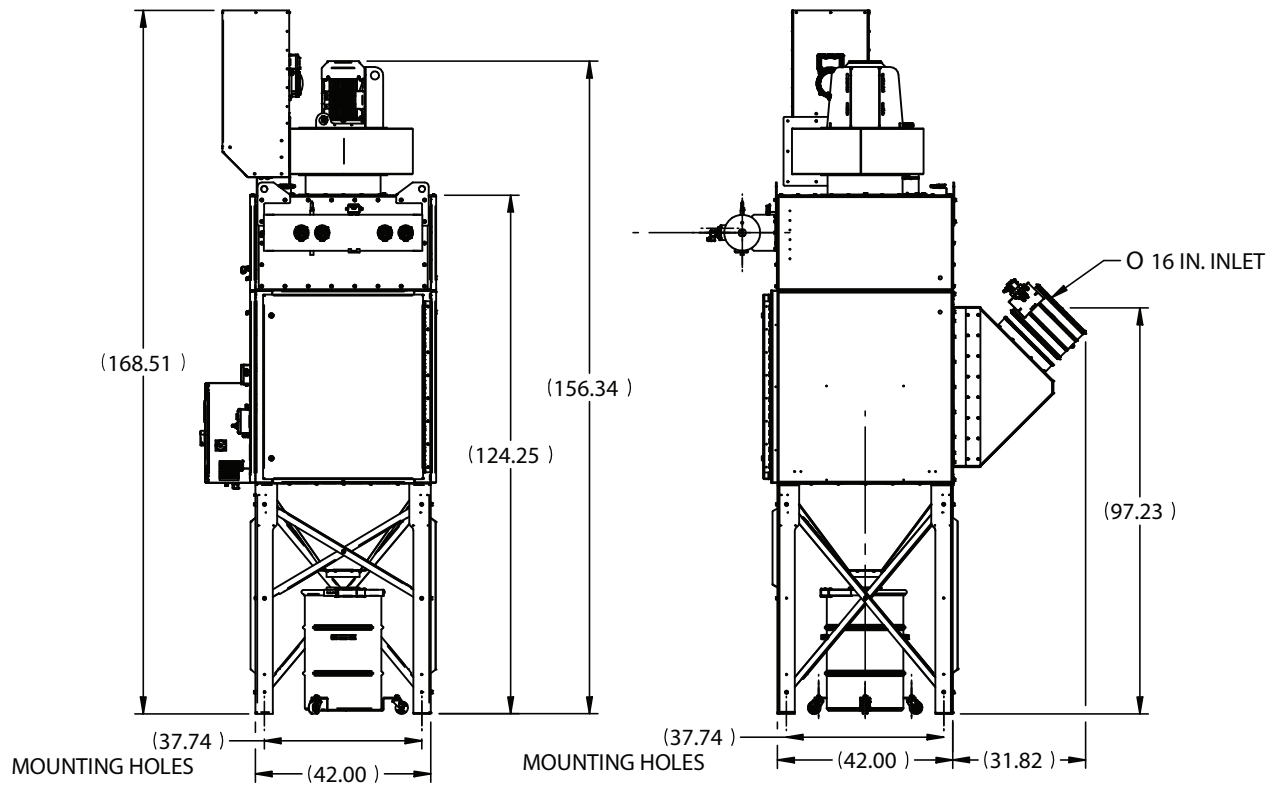
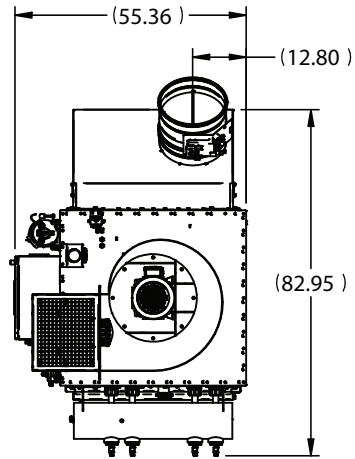

AD1326-33

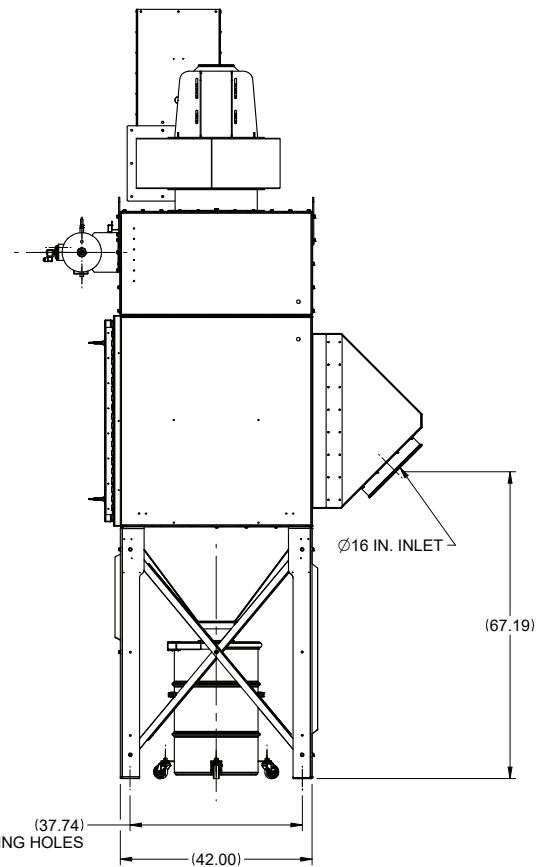
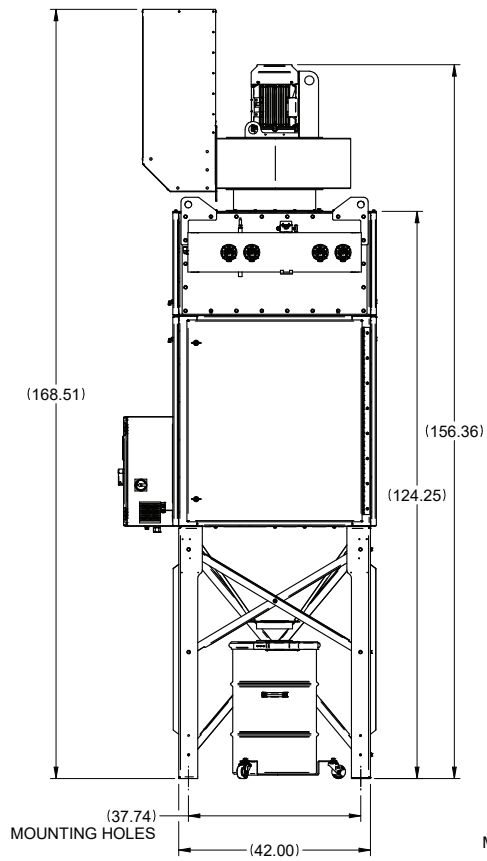
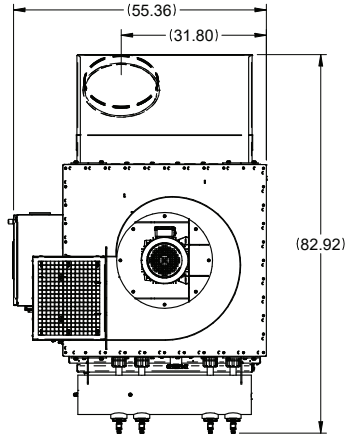

AD1326-34

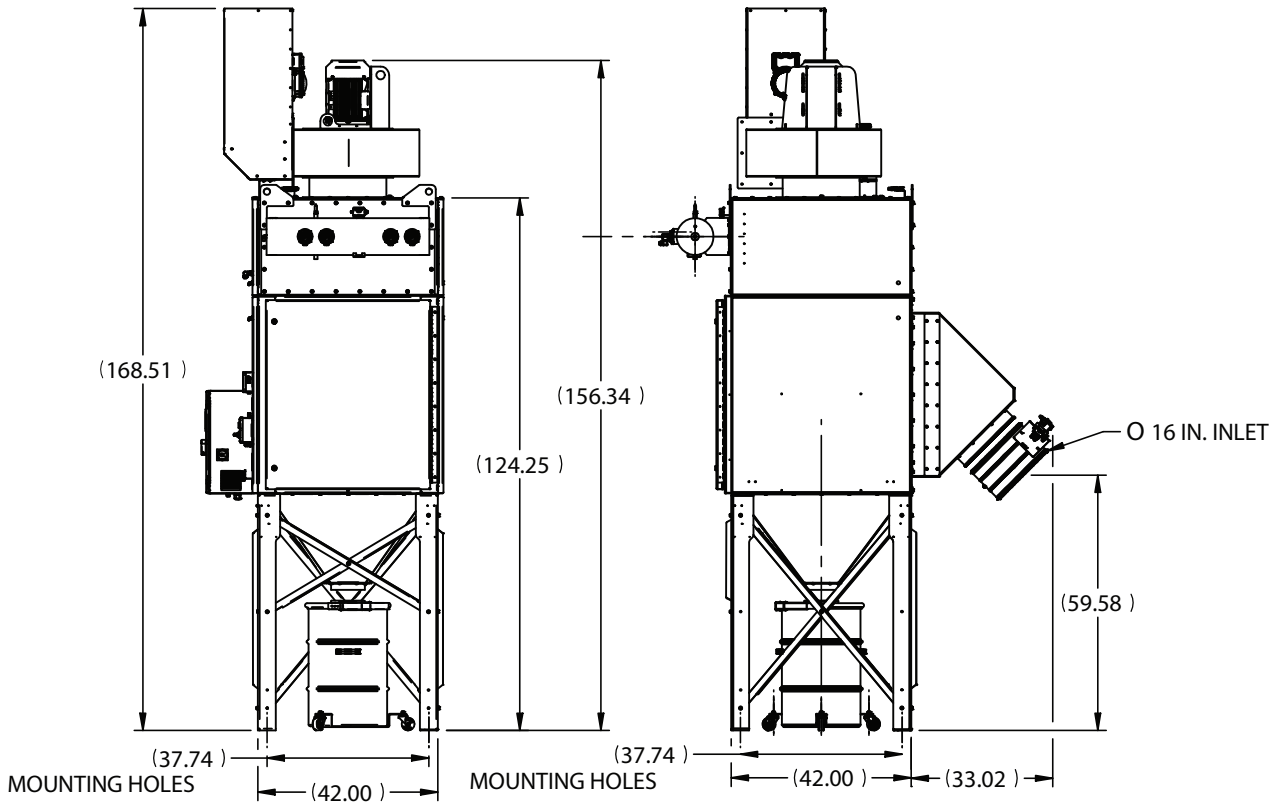
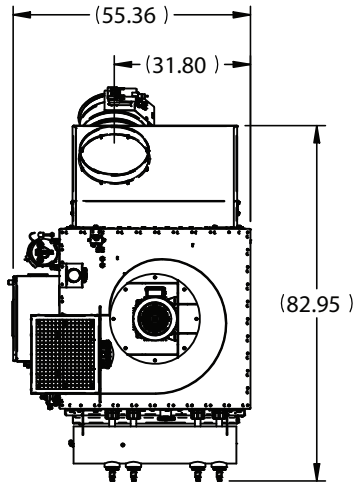

WARNING	<ul style="list-style-type: none"> Do not touch electrically live parts or electrode with skin or wet clothing. Insulate yourself from work and ground. 	<ul style="list-style-type: none"> Keep flammable materials away. 	<ul style="list-style-type: none"> Wear eye, ear and body protection.
Spanish AVISO DE PRECAUCION	<ul style="list-style-type: none"> No toque las partes o los electrodos bajo carga con la piel o ropa mojada. Aíslese del trabajo y de la tierra. 	<ul style="list-style-type: none"> Mantenga el material combustible fuera del área de trabajo. 	<ul style="list-style-type: none"> Protéjase los ojos, los oídos y el cuerpo.
French ATTENTION	<ul style="list-style-type: none"> Ne laissez ni la peau ni des vêtements mouillés entrer en contact avec des pièces sous tension. Isolez-vous du travail et de la terre. 	<ul style="list-style-type: none"> Gardez à l'écart de tout matériel inflammable. 	<ul style="list-style-type: none"> Protégez vos yeux, vos oreilles et votre corps.
German WARNUNG	<ul style="list-style-type: none"> Berühren Sie keine stromführenden Teile oder Elektroden mit Ihrem Körper oder feuchter Kleidung! Isolieren Sie sich von den Elektroden und dem Erdboden! 	<ul style="list-style-type: none"> Entfernen Sie brennbares Material! 	<ul style="list-style-type: none"> Tragen Sie Augen-, Ohren- und Körperschutz!
Portuguese ATENÇÃO	<ul style="list-style-type: none"> Não toque partes elétricas e electrodos com a pele ou roupa molhada. Isole-se da peça e terra. 	<ul style="list-style-type: none"> Mantenha inflamáveis bem guardados. 	<ul style="list-style-type: none"> Use proteção para a vista, ouvido e corpo.
Japanese 注意事項	<ul style="list-style-type: none"> 通電中の電気部品、又は溶材にヒブやぬれた布で触れないこと。 施工物やアースから身体が絶縁されている様にして下さい。 	<ul style="list-style-type: none"> 燃えやすいものの側での溶接作業は絶対にしてはなりません。 	<ul style="list-style-type: none"> 目、耳及び身体に保護具をして下さい。
Chinese 警告	<ul style="list-style-type: none"> 皮肤或湿衣物切勿接触带电部件及焊条。 使你自已与地面和工作件绝缘。 	<ul style="list-style-type: none"> 把一切易燃物品移离工作场所。 	<ul style="list-style-type: none"> 佩戴眼、耳及身体劳动保护用具。
Korean 위험	<ul style="list-style-type: none"> 전도체나 용접봉을 젖은 헝겍 또는 피부로 절대 접촉치 마십시오. 모재와 접지를 접촉치 마십시오. 	<ul style="list-style-type: none"> 인화성 물질을 접근시키지 마십시오. 	<ul style="list-style-type: none"> 눈, 귀와 몸에 보호장구를 착용하십시오.
Arabic تحذير	<ul style="list-style-type: none"> لا تلمس الاجزاء التي يسري فيها التيار الكهربائي أو الألكترود بجسدك أو بالملابس المبللة بالماء. ضع عازلا على جسمك خلال العمل. 	<ul style="list-style-type: none"> ضع المواد القابلة للاشتعال في مكان بعيد. 	<ul style="list-style-type: none"> ضع أدوات وملابس واقية على عينيك وأذنيك وجسمك.

READ AND UNDERSTAND THE MANUFACTURER'S INSTRUCTION FOR THIS EQUIPMENT AND THE CONSUMABLES TO BE USED AND FOLLOW YOUR EMPLOYER'S SAFETY PRACTICES.

SE RECOMIENDA LEER Y ENTENDER LAS INSTRUCCIONES DEL FABRICANTE PARA EL USO DE ESTE EQUIPO Y LOS CONSUMIBLES QUE VA A UTILIZAR, SIGA LAS MEDIDAS DE SEGURIDAD DE SU SUPERVISOR.

LISEZ ET COMPRENEZ LES INSTRUCTIONS DU FABRICANT EN CE QUI REGARDE CET EQUIPMENT ET LES PRODUITS A ETRE EMPLOYES ET SUIVEZ LES PROCEDURES DE SECURITE DE VOTRE EMPLOYEUR.

LESEN SIE UND BEFOLGEN SIE DIE BETRIEBSANLEITUNG DER ANLAGE UND DEN ELEKTRODENEINSATZ DES HERSTELLERS. DIE UNFALLVERHÜTUNGSVORSCHRIFTEN DES ARBEITGEBERS SIND EBENFALLS ZU BEACHTEN.

			
<ul style="list-style-type: none"> ● Keep your head out of fumes. ● Use ventilation or exhaust to remove fumes from breathing zone. 	<ul style="list-style-type: none"> ● Turn power off before servicing. 	<ul style="list-style-type: none"> ● Do not operate with panel open or guards off. 	WARNING
<ul style="list-style-type: none"> ● Los humos fuera de la zona de respiración. ● Mantenga la cabeza fuera de los humos. Utilice ventilación o aspiración para gases. 	<ul style="list-style-type: none"> ● Desconectar el cable de alimentación de poder de la máquina antes de iniciar cualquier servicio. 	<ul style="list-style-type: none"> ● No operar con panel abierto o guardas quitadas. 	Spanish AVISO DE PRECAUCION
<ul style="list-style-type: none"> ● Gardez la tête à l'écart des fumées. ● Utilisez un ventilateur ou un aspirateur pour ôter les fumées des zones de travail. 	<ul style="list-style-type: none"> ● Débranchez le courant avant l'entretien. 	<ul style="list-style-type: none"> ● N'opérez pas avec les panneaux ouverts ou avec les dispositifs de protection enlevés. 	French ATTENTION
<ul style="list-style-type: none"> ● Vermeiden Sie das Einatmen von Schweißrauch! ● Sorgen Sie für gute Be- und Entlüftung des Arbeitsplatzes! 	<ul style="list-style-type: none"> ● Strom vor Wartungsarbeiten abschalten! (Netzstrom völlig öffnen; Maschine anhalten!) 	<ul style="list-style-type: none"> ● Anlage nie ohne Schutzgehäuse oder Innenschutzverkleidung in Betrieb setzen! 	German WARNUNG
<ul style="list-style-type: none"> ● Mantenha seu rosto da fumaça. ● Use ventilação e exaustão para remover fumo da zona respiratória. 	<ul style="list-style-type: none"> ● Não opere com as tampas removidas. ● Desligue a corrente antes de fazer serviço. ● Não toque as partes elétricas nuas. 	<ul style="list-style-type: none"> ● Mantenha-se afastado das partes moventes. ● Não opere com os painéis abertos ou guardas removidas. 	Portuguese ATENÇÃO
<ul style="list-style-type: none"> ● ヒュームから頭を離すようにして下さい。 ● 換気や排煙に十分留意して下さい。 	<ul style="list-style-type: none"> ● メンテナンス・サービスに取りかかる際には、まず電源スイッチを必ず切して下さい。 	<ul style="list-style-type: none"> ● パネルやカバーを取り外したままで機械操作をしないで下さい。 	Japanese 注意事項
<ul style="list-style-type: none"> ● 頭部遠離煙霧。 ● 在呼吸區使用通風或排風器除煙。 	<ul style="list-style-type: none"> ● 維修前切斷電源。 	<ul style="list-style-type: none"> ● 儀表板打開或沒有安全罩時不準作業。 	Chinese 警告
<ul style="list-style-type: none"> ● 얼굴로부터 용접가스를 멀리하십시오. ● 호흡지역으로부터 용접가스를 제거하기 위해 가스제거기나 통풍기를 사용하십시오. 	<ul style="list-style-type: none"> ● 보수전에 전원을 차단하십시오. 	<ul style="list-style-type: none"> ● 판넬이 열린 상태로 작동치 마십시오. 	Korean 위험
<ul style="list-style-type: none"> ● ابعد رأسك بعيداً عن الدخان. ● استعمل التهوية أو جهاز ضغط الدخان للخارج لكي تبعد الدخان عن المنطقة التي تتنفس فيها. 	<ul style="list-style-type: none"> ● أقطع التيار الكهربائي قبل القيام بأية صيانة. 	<ul style="list-style-type: none"> ● لا تشغيل هذا الجهاز اذا كانت الاغطية الحديدية الواقية ليست عليه. 	Arabic تحذير

LEIA E COMPREENDA AS INSTRUÇÕES DO FABRICANTE PARA ESTE EQUIPAMENTO E AS PARTES DE USO, E SIGA AS PRÁTICAS DE SEGURANÇA DO EMPREGADOR.

使う機械や溶材のメーカーの指示書をよく読み、まず理解して下さい。そして貴社の安全規定に従って下さい。

請詳細閱讀並理解製造廠提供的說明以及應該使用的銀焊材料，並請遵守貴方的有關勞動保護規定。

이 제품에 동봉된 작업지침서를 숙지하시고 귀사의 작업자 안전수칙을 준수하시기 바랍니다.

اقرأ بتمعن وافهم تعليمات المصنع المنتج لهذه المعدات والمواد قبل استعمالها واتبع تعليمات الوقاية لصاحب العمل.

CUSTOMER ASSISTANCE POLICY

The business of Lincoln Electric is manufacturing and selling high quality welding equipment, automated welding systems, consumables, and cutting equipment. Our challenge is to meet the needs of our customers, who are experts in their fields, and to exceed their expectations. On occasion, purchasers may ask Lincoln Electric for information or technical information about their use of our products. Our employees respond to inquiries to the best of their ability based on information and specifications provided to them by the customers and the knowledge they may have concerning the application. Our employees, however, are not in a position to verify the information provided or to evaluate the engineering requirements for the particular weldment, or to provide engineering advice in relation to a specific situation or application. Accordingly, Lincoln Electric does not warrant or guarantee or assume any liability with respect to such information or communications. Moreover, the provision of such information or technical information does not create, expand, or alter any warranty on our products. Any express or implied warranty that might arise from the information or technical information, including any implied warranty of merchantability or any warranty of fitness for any customers' particular purpose or any other equivalent or similar warranty is specifically disclaimed.

Lincoln Electric is a responsive manufacturer, but the definition of specifications, and the selection and use of specific products sold by Lincoln Electric is solely within the control of, and remains the sole responsibility of the customer. Many variables beyond the control of Lincoln Electric affect the results obtained in applying these types of fabrication methods and service requirements.

WELD FUME CONTROL EQUIPMENT

The operation of welding fume control equipment is affected by various factors including proper use and positioning of the equipment, maintenance of the equipment and the specific welding procedure and application involved. Worker exposure level should be checked upon installation and periodically thereafter to be certain it is within applicable OSHA PEL and ACGIH TLV limits.



THE LINCOLN ELECTRIC COMPANY

22801 St. Clair Avenue • Cleveland, OH • 44117-1199 • U.S.A.
Phone: +1.216.481.8100 • www.lincolnelectric.com