

Operator's Manual

POWER WAVE[®] R500

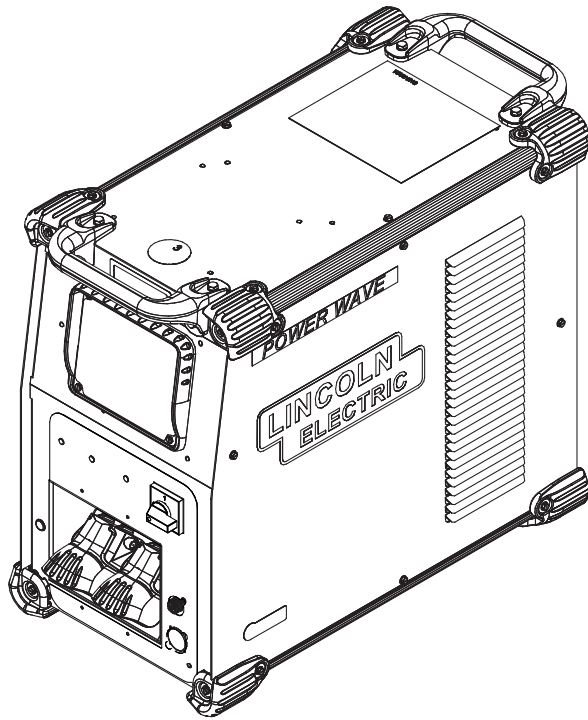

For use with machines having Code Numbers:

12483



Register your machine:
www.lincolnelectric.com/register

Authorized Service and Distributor Locator:
www.lincolnelectric.com/locator

Save for future reference

Date Purchased

Code: (ex: 10859)

Serial: (ex: U1060512345)

Need Help? Call 1.888.935.3877
to talk to a Service Representative

Hours of Operation:
8:00 AM to 6:00 PM (ET) Mon. thru Fri.

After hours?
Use "Ask the Experts" at lincolnelectric.com
A Lincoln Service Representative will contact you
no later than the following business day.

For Service outside the USA:
Email: globalservice@lincolnelectric.com

THANK YOU FOR SELECTING A QUALITY PRODUCT BY LINCOLN ELECTRIC.

PLEASE EXAMINE CARTON AND EQUIPMENT FOR DAMAGE IMMEDIATELY

When this equipment is shipped, title passes to the purchaser upon receipt by the carrier. Consequently, claims for material damaged in shipment must be made by the purchaser against the transportation company at the time the shipment is received.

SAFETY DEPENDS ON YOU

Lincoln arc welding and cutting equipment is designed and built with safety in mind. However, your overall safety can be increased by proper installation ... and thoughtful operation on your part. **DO NOT INSTALL, OPERATE OR REPAIR THIS EQUIPMENT WITHOUT READING THIS MANUAL AND THE SAFETY PRECAUTIONS CONTAINED THROUGHOUT.** And, most importantly, think before you act and be careful.

WARNING

This statement appears where the information must be followed exactly to avoid serious personal injury or loss of life.

CAUTION

This statement appears where the information must be followed to avoid minor personal injury or damage to this equipment.



KEEP YOUR HEAD OUT OF THE FUMES.

DON'T get too close to the arc. Use corrective lenses if necessary to stay a reasonable distance away from the arc.

READ and obey the Safety Data Sheet (SDS) and the warning label that appears on all containers of welding materials.

USE ENOUGH VENTILATION or exhaust at the arc, or both, to keep the fumes and gases from your breathing zone and the general area.

IN A LARGE ROOM OR OUTDOORS, natural ventilation may be adequate if you keep your head out of the fumes (See below).

USE NATURAL DRAFTS or fans to keep the fumes away from your face.

If you develop unusual symptoms, see your supervisor. Perhaps the welding atmosphere and ventilation system should be checked.

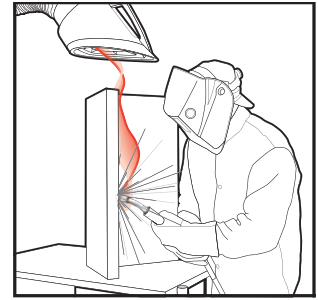

WEAR CORRECT EYE, EAR & BODY PROTECTION

PROTECT your eyes and face with welding helmet properly fitted and with proper grade of filter plate (See ANSI Z49.1).

PROTECT your body from welding spatter and arc flash with protective clothing including woolen clothing, flame-proof apron and gloves, leather leggings, and high boots.

PROTECT others from splatter, flash, and glare with protective screens or barriers.

IN SOME AREAS, protection from noise may be appropriate.

BE SURE protective equipment is in good condition.

Also, wear safety glasses in work area **AT ALL TIMES.**



SPECIAL SITUATIONS

DO NOT WELD OR CUT containers or materials which previously had been in contact with hazardous substances unless they are properly cleaned. This is extremely dangerous.

DO NOT WELD OR CUT painted or plated parts unless special precautions with ventilation have been taken. They can release highly toxic fumes or gases.

Additional precautionary measures

PROTECT compressed gas cylinders from excessive heat, mechanical shocks, and arcs; fasten cylinders so they cannot fall.

BE SURE cylinders are never grounded or part of an electrical circuit.

REMOVE all potential fire hazards from welding area.

ALWAYS HAVE FIRE FIGHTING EQUIPMENT READY FOR IMMEDIATE USE AND KNOW HOW TO USE IT.



SECTION A: WARNINGS



CALIFORNIA PROPOSITION 65 WARNINGS



WARNING: Breathing diesel engine exhaust exposes you to chemicals known to the State of California to cause cancer and birth defects, or other reproductive harm.

- Always start and operate the engine in a well-ventilated area.
- If in an exposed area, vent the exhaust to the outside.
- Do not modify or tamper with the exhaust system.
- Do not idle the engine except as necessary.

For more information go to www.P65warnings.ca.gov/diesel

WARNING: This product, when used for welding or cutting, produces fumes or gases which contain chemicals known to the State of California to cause birth defects and, in some cases, cancer. (California Health & Safety Code § 25249.5 *et seq.*)



WARNING: Cancer and Reproductive Harm
www.P65warnings.ca.gov

ARC WELDING CAN BE HAZARDOUS. PROTECT YOURSELF AND OTHERS FROM POSSIBLE SERIOUS INJURY OR DEATH. KEEP CHILDREN AWAY. PACEMAKER WEARERS SHOULD CONSULT WITH THEIR DOCTOR BEFORE OPERATING.

Read and understand the following safety highlights. For additional safety information, it is strongly recommended that you purchase a copy of "Safety in Welding & Cutting - ANSI Standard Z49.1" from the American Welding Society, P.O. Box 351040, Miami, Florida 33135 or CSA Standard W117.2-1974. A Free copy of "Arc Welding Safety" booklet E205 is available from the Lincoln Electric Company, 22801 St. Clair Avenue, Cleveland, Ohio 44117-1199.

BE SURE THAT ALL INSTALLATION, OPERATION, MAINTENANCE AND REPAIR PROCEDURES ARE PERFORMED ONLY BY QUALIFIED INDIVIDUALS.



FOR ENGINE POWERED EQUIPMENT.

- 1.a. Turn the engine off before troubleshooting and maintenance work unless the maintenance work requires it to be running.
- 1.b. Operate engines in open, well-ventilated areas or vent the engine exhaust fumes outdoors.
- 1.c. Do not add the fuel near an open flame welding arc or when the engine is running. Stop the engine and allow it to cool before refueling to prevent spilled fuel from vaporizing on contact



with hot engine parts and igniting. Do not spill fuel when filling tank. If fuel is spilled, wipe it up and do not start engine until fumes have been eliminated.

- 1.d. Keep all equipment safety guards, covers and devices in position and in good repair. Keep hands, hair, clothing and tools away from V-belts, gears, fans and all other moving parts when starting, operating or repairing equipment.
- 1.e. In some cases it may be necessary to remove safety guards to perform required maintenance. Remove guards only when necessary and replace them when the maintenance requiring their removal is complete. Always use the greatest care when working near moving parts.
- 1.f. Do not put your hands near the engine fan. Do not attempt to override the governor or idler by pushing on the throttle control rods while the engine is running.
- 1.g. To prevent accidentally starting gasoline engines while turning the engine or welding generator during maintenance work, disconnect the spark plug wires, distributor cap or magneto wire as appropriate.
- 1.h. To avoid scalding, do not remove the radiator pressure cap when the engine is hot.



ELECTRIC AND MAGNETIC FIELDS MAY BE DANGEROUS



- 2.a. Electric current flowing through any conductor causes localized Electric and Magnetic Fields (EMF). Welding current creates EMF fields around welding cables and welding machines
- 2.b. EMF fields may interfere with some pacemakers, and welders having a pacemaker should consult their physician before welding.
- 2.c. Exposure to EMF fields in welding may have other health effects which are now not known.
- 2.d. All welders should use the following procedures in order to minimize exposure to EMF fields from the welding circuit:
 - 2.d.1. Route the electrode and work cables together - Secure them with tape when possible.
 - 2.d.2. Never coil the electrode lead around your body.
 - 2.d.3. Do not place your body between the electrode and work cables. If the electrode cable is on your right side, the work cable should also be on your right side.
 - 2.d.4. Connect the work cable to the workpiece as close as possible to the area being welded.
 - 2.d.5. Do not work next to welding power source.



ELECTRIC SHOCK CAN KILL.



- 3.a. The electrode and work (or ground) circuits are electrically “hot” when the welder is on. Do not touch these “hot” parts with your bare skin or wet clothing. Wear dry, hole-free gloves to insulate hands.
- 3.b. Insulate yourself from work and ground using dry insulation. Make certain the insulation is large enough to cover your full area of physical contact with work and ground.

In addition to the normal safety precautions, if welding must be performed under electrically hazardous conditions (in damp locations or while wearing wet clothing; on metal structures such as floors, gratings or scaffolds; when in cramped positions such as sitting, kneeling or lying, if there is a high risk of unavoidable or accidental contact with the workpiece or ground) use the following equipment:

- Semiautomatic DC Constant Voltage (Wire) Welder.
 - DC Manual (Stick) Welder.
 - AC Welder with Reduced Voltage Control.
- 3.c. In semiautomatic or automatic wire welding, the electrode, electrode reel, welding head, nozzle or semiautomatic welding gun are also electrically “hot”.
 - 3.d. Always be sure the work cable makes a good electrical connection with the metal being welded. The connection should be as close as possible to the area being welded.
 - 3.e. Ground the work or metal to be welded to a good electrical (earth) ground.
 - 3.f. Maintain the electrode holder, work clamp, welding cable and welding machine in good, safe operating condition. Replace damaged insulation.
 - 3.g. Never dip the electrode in water for cooling.
 - 3.h. Never simultaneously touch electrically “hot” parts of electrode holders connected to two welders because voltage between the two can be the total of the open circuit voltage of both welders.
 - 3.i. When working above floor level, use a safety belt to protect yourself from a fall should you get a shock.
 - 3.j. Also see Items 6.c. and 8.



ARC RAYS CAN BURN.



- 4.a. Use a shield with the proper filter and cover plates to protect your eyes from sparks and the rays of the arc when welding or observing open arc welding. Headshield and filter lens should conform to ANSI Z87.1 standards.
- 4.b. Use suitable clothing made from durable flame-resistant material to protect your skin and that of your helpers from the arc rays.
- 4.c. Protect other nearby personnel with suitable, non-flammable screening and/or warn them not to watch the arc nor expose themselves to the arc rays or to hot spatter or metal.



FUMES AND GASES CAN BE DANGEROUS.



- 5.a. Welding may produce fumes and gases hazardous to health. Avoid breathing these fumes and gases. When welding, keep your head out of the fume. Use enough ventilation and/or exhaust at the arc to keep fumes and gases away from the breathing zone. **When welding hardfacing (see instructions on container or SDS) or on lead or cadmium plated steel and other metals or coatings which produce highly toxic fumes, keep exposure as low as possible and within applicable OSHA PEL and ACGIH TLV limits using local exhaust or mechanical ventilation unless exposure assessments indicate otherwise. In confined spaces or in some circumstances, outdoors, a respirator may also be required. Additional precautions are also required when welding on galvanized steel.**
- 5.b. The operation of welding fume control equipment is affected by various factors including proper use and positioning of the equipment, maintenance of the equipment and the specific welding procedure and application involved. Worker exposure level should be checked upon installation and periodically thereafter to be certain it is within applicable OSHA PEL and ACGIH TLV limits.
- 5.c. Do not weld in locations near chlorinated hydrocarbon vapors coming from degreasing, cleaning or spraying operations. The heat and rays of the arc can react with solvent vapors to form phosgene, a highly toxic gas, and other irritating products.
- 5.d. Shielding gases used for arc welding can displace air and cause injury or death. Always use enough ventilation, especially in confined areas, to insure breathing air is safe.
- 5.e. Read and understand the manufacturer’s instructions for this equipment and the consumables to be used, including the Safety Data Sheet (SDS) and follow your employer’s safety practices. SDS forms are available from your welding distributor or from the manufacturer.
- 5.f. Also see item 1.b.



WELDING AND CUTTING SPARKS CAN CAUSE FIRE OR EXPLOSION.



- 6.a. Remove fire hazards from the welding area. If this is not possible, cover them to prevent the welding sparks from starting a fire. Remember that welding sparks and hot materials from welding can easily go through small cracks and openings to adjacent areas. Avoid welding near hydraulic lines. Have a fire extinguisher readily available.
- 6.b. Where compressed gases are to be used at the job site, special precautions should be used to prevent hazardous situations. Refer to "Safety in Welding and Cutting" (ANSI Standard Z49.1) and the operating information for the equipment being used.
- 6.c. When not welding, make certain no part of the electrode circuit is touching the work or ground. Accidental contact can cause overheating and create a fire hazard.
- 6.d. Do not heat, cut or weld tanks, drums or containers until the proper steps have been taken to insure that such procedures will not cause flammable or toxic vapors from substances inside. They can cause an explosion even though they have been "cleaned". For information, purchase "Recommended Safe Practices for the Preparation for Welding and Cutting of Containers and Piping That Have Held Hazardous Substances", AWS F4.1 from the American Welding Society (see address above).
- 6.e. Vent hollow castings or containers before heating, cutting or welding. They may explode.
- 6.f. Sparks and spatter are thrown from the welding arc. Wear oil free protective garments such as leather gloves, heavy shirt, cuffless trousers, high shoes and a cap over your hair. Wear ear plugs when welding out of position or in confined places. Always wear safety glasses with side shields when in a welding area.
- 6.g. Connect the work cable to the work as close to the welding area as practical. Work cables connected to the building framework or other locations away from the welding area increase the possibility of the welding current passing through lifting chains, crane cables or other alternate circuits. This can create fire hazards or overheat lifting chains or cables until they fail.
- 6.h. Also see item 1.c.
- 6.i. Read and follow NFPA 51B "Standard for Fire Prevention During Welding, Cutting and Other Hot Work", available from NFPA, 1 Batterymarch Park, PO box 9101, Quincy, MA 022690-9101.
- 6.j. Do not use a welding power source for pipe thawing.



CYLINDER MAY EXPLODE IF DAMAGED.



- 7.a. Use only compressed gas cylinders containing the correct shielding gas for the process used and properly operating regulators designed for the gas and pressure used. All hoses, fittings, etc. should be suitable for the application and maintained in good condition.
- 7.b. Always keep cylinders in an upright position securely chained to an undercarriage or fixed support.
- 7.c. Cylinders should be located:
 - Away from areas where they may be struck or subjected to physical damage.
 - A safe distance from arc welding or cutting operations and any other source of heat, sparks, or flame.
- 7.d. Never allow the electrode, electrode holder or any other electrically "hot" parts to touch a cylinder.
- 7.e. Keep your head and face away from the cylinder valve outlet when opening the cylinder valve.
- 7.f. Valve protection caps should always be in place and hand tight except when the cylinder is in use or connected for use.
- 7.g. Read and follow the instructions on compressed gas cylinders, associated equipment, and CGA publication P-1, "Precautions for Safe Handling of Compressed Gases in Cylinders," available from the Compressed Gas Association, 14501 George Carter Way Chantilly, VA 20151.



FOR ELECTRICALLY POWERED EQUIPMENT.



- 8.a. Turn off input power using the disconnect switch at the fuse box before working on the equipment.
- 8.b. Install equipment in accordance with the U.S. National Electrical Code, all local codes and the manufacturer's recommendations.
- 8.c. Ground the equipment in accordance with the U.S. National Electrical Code and the manufacturer's recommendations.

Refer to
<http://www.lincolnelectric.com/safety>
for additional safety information.

Installation.....	Section A
Technical Specifications	A-1, A-2
Safety Precautions	A-3
Location, Lifting	A-3
Stacking	A-3
Tilting	A-3
Input and Ground Connections	A-3
Machine Grounding.....	A-3
High Frequency Protection	A-3
Input Connection	A-4
Input Fuse and Supply Wire.....	A-4
Input Voltage Selection	A-4
Connection Diagram MIG Process	A-5
Recommended Work Cable Sizes.....	A-6
Cable Inductance and its Effects on Welding	A-7
Remote Sense Lead Specifications	A-7, A-8
Voltage Sensing Considerations for Multiple Arc System	A-9, A-10
Control Cable Connections	A-11

Operation.....	Section B
Safety Precautions	B-1
Power-Up Sequence.....	B-1
Duty Cycle	B-1
Graphic Symbols	B-1
Product Description.....	B-2
Recommended Processes and Equipment.....	B-2
Equipment Limitations	B-2
Design Features.....	B-3
Case Front Controls.....	B-3
Case Back Controls.....	B-4
Common Welding Procedures	B-5 thru B-7

Accessories.....	Section C
Kits, Options / Accessories.....	C-1
Field Installed Options.....	C-1
Stick Operations	C-1

Maintenance.....	Section D
Safety Precautions.....	D-1
Routine Maintenance	D-1
Periodic Maintenance	D-1
Calibration Specification	D-1

Troubleshooting	Section E
Safety Precautions	E-1
How to Use Troubleshooting Guide	E-1
Using Status LED, Error Fault Codes and Input Control Board	E-2, E-4
Troubleshooting Guide.....	E-5 thru E-8

Wiring Diagram and Dimension Print	Section F
---	------------------

Parts List.....parts.lincolnelectric.com

Content/details may be changed or updated without notice. For most current Instruction Manuals, go to parts.lincolnelectric.com.

TECHNICAL SPECIFICATIONS - POWER WAVE® R500

POWER SOURCE-INPUT VOLTAGE AND CURRENT										
Model	Duty Cycle	Input Voltage \pm 10%			Input Amperes			Idle Power	Power Factor @ Rated Output	
K3169-2	40% rating	400*/460/575 50/60 Hz (*includes 380V to 415V)			41/37/29			500 Watts Max. (fan on)	.95	
	100% rating				30/27/21					
RATED OUTPUT										
INPUT VOLTAGE/PHASE/ FREQUENCY	GMAW			SMAW			GTAW-DC			
	40%	60%	100%	40%	60%	100%	40%	60%	100%	
380-415/3/50/60	550 Amps 41.5 Volts	500 Amps 39 Volts	450 Amps 36.5 Volts	550 Amps 42 Volts	500 Amps 40 Volts	450 Amps 38 Volts	550 Amps 32 Volts	500 Amps 30 Volts	450 Amps 28 Volts	
460/3/50/60										
575/3/50/60										
RECOMMENDED INPUT WIRE AND FUSE SIZES ¹										
INPUT VOLTAGE / PHASE/ FREQUENCY		MAXIMUM INPUT AMPERE RATING AND DUTY CYCLE			CORD SIZE ³ AWG SIZES (mm ²)		TIME DELAY FUSE OR BREAKER ² AMPERAGE			
380-415/3/50/60 460/3/50/60 575/3/50/60		41A, 40% 37A, 40% 29A, 40%			8 (10) 8 (10) 10 (7)		60 45 35			

1. Based on U.S. National electrical Code

2. Also called "inverse time" or "thermal / magnetic" circuit breakers; circuit breakers that have a delay in tripping action that decreases as the magnitude of the current increases

3. Type SO cord or similar in 30° C ambient at effective current rating of unit.

WELDING PROCESS			
PROCESS	OUTPUT RANGE (AMPERES)	OCV (U_o)	
		Mean	Peak
GMAW	40-550A	70V	73V
GMAW-Pulse			
FCAW			
GTAW-DC	5-550A	24V	36V
SMAW	55-550A	60V	63V

PHYSICAL DIMENSIONS				
MODEL	HEIGHT	WIDTH	DEPTH	WEIGHT
K3169-2	22.45 in (570 mm)	14.00in (356 mm)	24.80in (630mm)	150 lbs (68 kg)*

TEMPERATURE RANGES	
OPERATING TEMPERATURE RANGE Environmentally Hardened: -4°F to 104°F (-20°C to 40°C)	STORAGE TEMPERATURE RANGE Environmentally Hardened: -40°F to 185°F (-40°C to 85°C)

IP23 155°F Insulation Class

* Weight does not include input cord.

SAFETY PRECAUTIONS Read this entire installation section before you start installation.



WARNING



ELECTRIC SHOCK can kill.

- Only qualified personnel should perform this installation.
- Turn the input power OFF at the disconnect switch or fuse box before working on this equipment. Turn off the input power to any other equipment connected to the welding system at the disconnect switch or fuse box before working on the equipment.
- Do not touch electrically hot parts.
- Always connect the POWER WAVE® R500 grounding lug to a proper safety (Earth) ground.

SELECT SUITABLE LOCATION

The POWER WAVE® R500 will operate in harsh environments. Even so, it is important that simple preventative measures are followed in order to assure long life and reliable operation.

- The machine must be located where there is free circulation of clean air such that air movement in the back, out the sides and bottom will not be restricted.
- Dirt and dust that can be drawn into the machine should be kept to a minimum. The use of air filters on the air intake is not recommended because normal air flow may be restricted. Failure to observe these precautions can result in excessive operating temperatures and nuisance shutdown.
- Keep machine dry. Shelter from rain and snow. Do not place on wet ground or in puddles.
- Do not mount the POWER WAVE® R500 over combustible surfaces. Where there is a combustible surface directly under stationary or fixed electrical equipment, that surface shall be covered with a steel plate at least .060" (1.6mm) thick, which shall extend not less than 5.90" (150mm) beyond the equipment on all sides.

This equipment is for industrial use only and it is not intended for use in residential locations where the electrical power is provided by the public low-voltage supply system. There can be potential difficulties in residential locations due to conducted as well as radiated radio-frequency disturbances. The EMC or RF classification of this equipment is Class A.

LIFTING

Both handles should be used when lifting POWER WAVE® R500. When using a crane or overhead device a lifting strap should be connected to both handles. Do not attempt to lift the POWER WAVE® R500 with accessories attached to it.

STACKING

The POWER WAVE® R500 cannot be stacked.

TILTING

Place the machine directly on a secure, level surface or on a recommended undercarriage. The machine may topple over if this procedure is not followed.

INPUT AND GROUND CONNECTIONS

Only a qualified electrician should connect the POWER WAVE® R500. Installation should be made in accordance with the appropriate National Electrical Code, all local codes and the information in this manual.



WARNING



- Lift only with equipment of adequate lifting capacity.
- Be sure machine is stable when lifting.
- Do not operate machine while suspended when lifting.

FALLING EQUIPMENT can cause injury.

MACHINE GROUNDING



The frame of the welder must be grounded. A ground terminal marked with a ground symbol is located next to the input power connection block.

See your local and national electrical codes for proper grounding methods.

HIGH FREQUENCY PROTECTION

Locate the POWER WAVE® R500 away from radio controlled machinery. The normal operation of the POWER WAVE® R500 may adversely affect the operation of RF controlled equipment, which may result in bodily injury or damage to the equipment.

⚠ WARNING

Only a qualified electrician should connect the input leads to the POWER WAVE® R500. Connections should be made in accordance with all local and national electrical codes and the connection diagrams. Failure to do so may result in bodily injury or death.

INPUT CONNECTION

(See Figure A.1)

Use a three-phase supply line. A 1.40 inch diameter access hole with strain relief is located on the case back. Route input power cable through this hole and connect L1, L2, L3 and ground per connection diagrams and National Electric Code. To access the input power connection block, remove three screws holding the access door to the side of the machine.

ALWAYS CONNECT THE POWER WAVE **GROUNDING LUG** (LOCATED AS SHOWN IN FIGURE A.1) TO A PROPER SAFETY (EARTH) GROUND.

INPUT FUSE AND SUPPLY WIRE CONSIDERATIONS

Refer to Specification Section for recommended fuse, wire sizes and type of the copper wires. Fuse the input circuit with the recommended super lag fuse or delay type breakers (also called "inverse time" or "thermal/magnetic" circuit breakers). Choose input and grounding wire size according to local or national electrical codes. Using input wire sizes, fuses or circuit breakers smaller than recommended may result in "nuisance" shut-offs from welder inrush currents, even if the machine is not being used at high currents.

INPUT VOLTAGE SELECTION

The POWER WAVE® R500 automatically adjusts to work with different input voltages. No reconnect switch settings are required.

⚠ WARNING

The POWER WAVE® R500 ON/OFF switch is not intended as a service disconnect for this equipment. Only a qualified electrician should connect the input leads to the POWER WAVE® R500. Connections should be made in accordance with all local and national electrical codes and the connection diagram located on the inside of the reconnect access door of the machine. Failure to do so may result in bodily injury or death.

FIGURE A.1

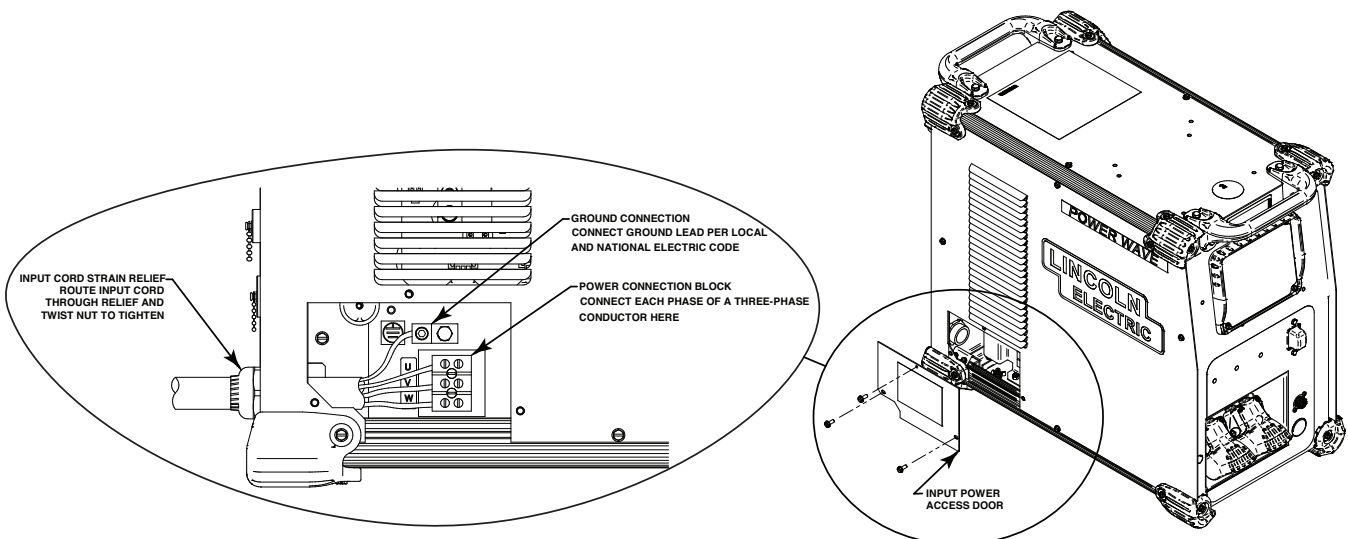

GMAW (MIG) WELDING

An arclink compatible wire feeder is recommended for Mig welding. Refer to **Figure A.3** for the connection details.

FIGURE A.3

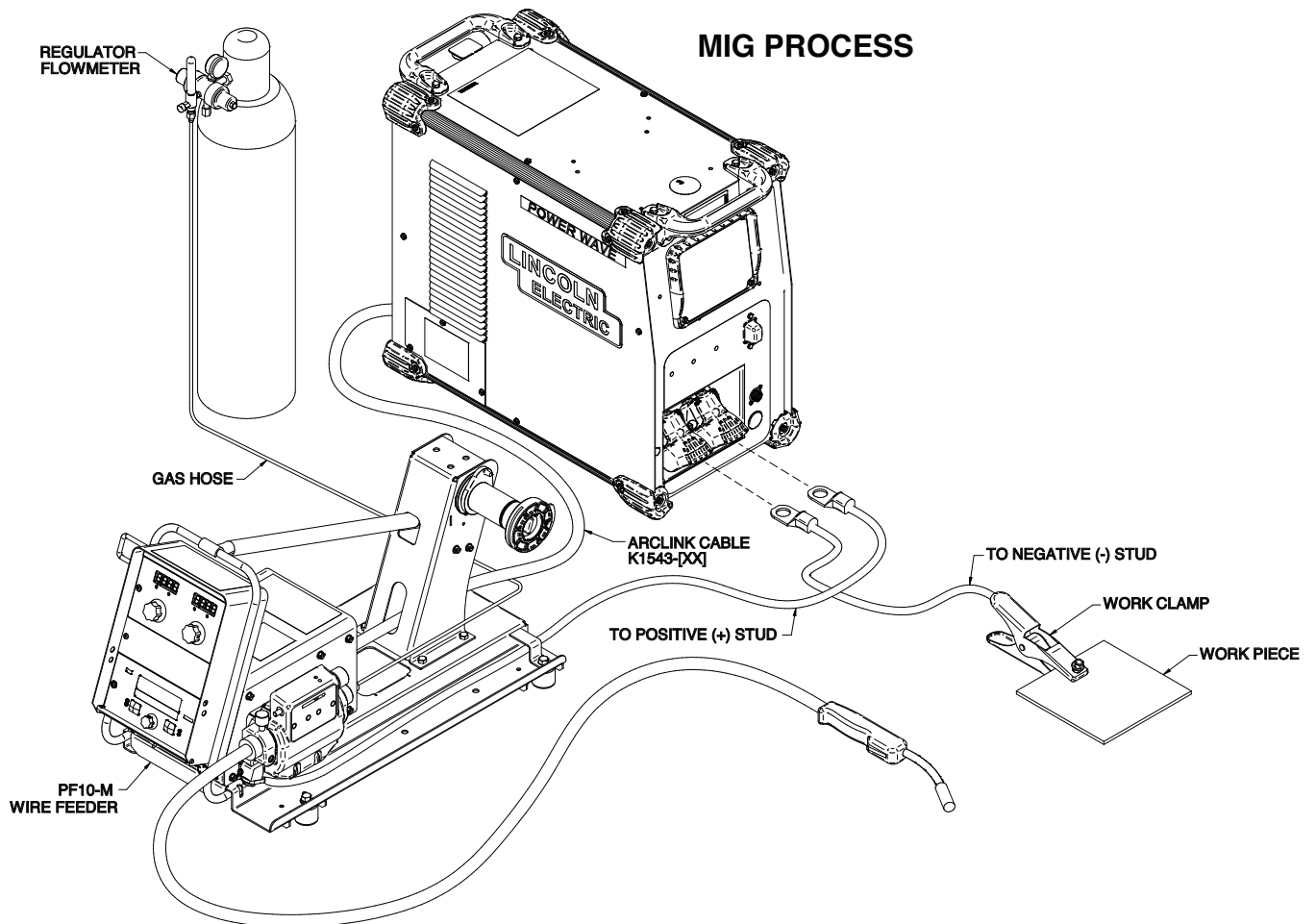

RECOMMENDED WORK CABLE SIZES FOR ARC WELDING

Connect the electrode and work cables between the appropriate output studs of the POWER WAVE® R500 per the following guidelines:

- Most welding applications run with the electrode being positive (+). For those applications, connect the electrode cable between the wire drive feed plate and the positive (+) output stud on the power source. Connect a work lead from the negative (-) power source output stud to the work piece
- When negative electrode polarity is required, such as in some Innershield applications, reverse the output connections at the power source (electrode cable to the negative (-) stud, and work cable to the positive (+) stud).

CAUTION

Negative electrode polarity operation **WITHOUT** use of a remote work sense lead (21) requires the **Negative Electrode Polarity** attribute to be set. See the **Remote Sense Lead Specification** section of this document for further details.

For additional Safety information regarding the electrode and work cable set-up, See the standard “**SAFETY INFORMATION**” located in the front of this Instruction Manual.

General Guidelines

- **Select the appropriate size cables per the “Output Cable Guidelines” below.** Excessive voltage drops caused by undersized welding cables and poor connections often result in unsatisfactory welding performance. Always use the largest welding cables (electrode and work) that are practical, and be sure all connections are clean and tight.

Note: Excessive heat in the weld circuit indicates undersized cables and/or bad connections.

- **Route all cables directly to the work and wire feeder, avoid excessive lengths and do not coil excess cable.** Route the electrode and work cables in close proximity to one another to minimize the loop area and therefore the inductance of the weld circuit.

- **Always weld in a direction away from the work (ground) connection.**

Table A.1 shows copper cable sizes recommended for different currents and duty cycles. Lengths stipulated are the distance from the welder to work and back to the welder again. Cable sizes are increased for greater lengths primarily for the purpose of minimizing cable drop.

OUTPUT CABLE GUIDELINES (Table A.1)						
Amperes	Percent Duty Cycle	CABLE SIZES FOR COMBINED LENGTHS OF ELECTRODE AND WORK CABLES [RUBBER COVERED COPPER - RATED 167°F (75°C)]**				
		0 to 50 Ft.	50 to 100 Ft.	100 to 150 Ft.	150 to 200 Ft.	200 to 250 Ft.
200	100	2	2	2	1	1/0
250	100	1	1	1	1	1/0
300	100	2/0	2/0	2/0	2/0	3/0
350	100	2/0	2/0	3/0	3/0	4/0
400	100	3/0	3/0	3/0	3/0	4/0
450	100	3/0	3/0	4/0	4/0	2-3/0
500	60	2/0	2/0	3/0	3/0	4/0
550	40	2/0	2/0	3/0	3/0	4/0

** Tabled values are for operation at ambient temperatures of 104°F (40°C) and below. Applications above 104°F (40°C) may require cables larger than recommended, or cables rated higher than 167°F (75°C).

CABLE INDUCTANCE AND ITS EFFECTS ON WELDING

Excessive cable inductance will cause the welding performance to degrade. There are several factors that contribute to the overall inductance of the cabling system including cable size, and loop area. The loop area is defined by the separation distance between the electrode and work cables, and the overall welding loop length. The welding loop length is defined as the total of length of the electrode cable (A) + work cable (B) + work path (C) (See Figure A.5).

To minimize inductance always use the appropriate size cables, and whenever possible, run the electrode and work cables in close proximity to one another to minimize the loop area. Since the most significant factor in cable inductance is the welding loop length, avoid excessive lengths and do not coil excess cable. For long work piece lengths, a sliding ground should be considered to keep the total welding loop length as short as possible.

REMOTE SENSE LEAD SPECIFICATIONS

Voltage Sensing Overview

The best arc performance occurs when the POWER WAVE® R500 has accurate data about the arc conditions. Depending upon the process, inductance within the electrode and work cables can influence the voltage apparent at the studs of the welder, and have a dramatic effect on performance. Remote volt-

age sense leads are used to improve the accuracy of the arc voltage information supplied to the control pc board. Sense Lead Kits (K940-xx) are available for this purpose.

The POWER WAVE® R500 has the ability to automatically sense when remote sense leads are connected. With this feature there are no requirements for setting-up the machine to use remote sense leads. This feature can be disabled through the Weld Manager Utility (available at www.powerwavesoftware.com) or through the set up menu (if a user interface is installed into the power source).

⚠ CAUTION

If the auto sense lead feature is disabled and remote voltage sensing is enabled but the sense leads are missing or improperly connected extremely high welding outputs may occur.

General Guidelines for Voltage Sense Leads

Sense leads should be attached as close to the weld as practical, and out of the weld current path when possible. In extremely sensitive applications it may be necessary to route cables that contain the sense leads away from the electrode and work welding cables.

Voltage sense leads requirements are based on the weld process (See Table A.2)

TABLE A.2

Process	Electrode Voltage Sensing ⁽¹⁾ 67 lead	Work Voltage Sensing ⁽²⁾ 21 lead
GMAW	67 lead required	21 lead optional ⁽³⁾
GMAW-P	67 lead required	21 lead optional ⁽³⁾
FCAW	67 lead required	21 lead optional ⁽³⁾
GTAW	Voltage sense at studs	Voltage sense at studs

- (1) The electrode voltage sense lead (67) is automatically enabled by the weld process, and integral to the 5 pin arclink control cable (K1543-xx).
- (2) When a work voltage sense lead (21) is connected the power source will automatically switch over to using this feedback (if the auto sense feature is enable).
- (3) Negative polarity semi-automatic process operation WITHOUT use of a remote work sense lead (21) requires the Negative Electrode Polarity attribute to be set.

FIGURE A.5

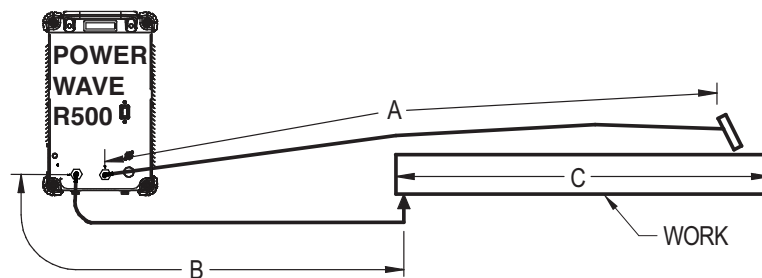

Electrode Voltage Sensing

The remote ELECTRODE sense lead (67) is built into the 5-pin arclink control cable and is always connected to the wire drive feed plate when a wire feeder is present. Enabling or disabling electrode voltage sensing is application specific, and automatically configured by the active weld mode.

CAUTION

If the auto sense lead feature is disabled and the weld polarity attribute is improperly configured extremely high welding outputs may occur.

Work Voltage Sensing

While most applications perform adequately by sensing the work voltage directly at the output stud, the use of a remote work voltage sense lead is recommended for optimal performance. The remote WORK sense lead (21) can be accessed through the four-pin voltage sense connector located on the control panel by using the K940 Sense Lead Kit. It must be attached to the work as close to the weld as practical, but out of the weld current path. For more information regarding the placement of remote work voltage sense leads, see in this section entitled "Voltage Sensing Considerations for Multiple Arc Systems."

Negative Electrode Polarity

The POWER WAVE® R500 has the ability to automatically sense the polarity of the sense leads. With this feature there are no set-up requirements for welding with negative electrode polarity. This feature can be disabled through the Weld Manager Utility (available at www.powerwavesoftware.com) or through the set up menu (if a user interface is installed into the power source).

VOLTAGE SENSING CONSIDERATIONS FOR MULTIPLE ARC SYSTEMS

Special care must be taken when more than one arc is welding simultaneously on a single part. Multiple arc applications do not necessarily dictate the use of remote work voltage sense leads, but they are strongly recommended.

If Sense Leads ARE NOT Used:

- Avoid common current paths. Current from adjacent arcs can induce voltage into each others current paths that can be misinterpreted by the power sources, and result in arc interference.

If Sense Leads ARE Used:

- Position the sense leads out of the path of the weld current. Especially any current paths common to adjacent arcs. Current from adjacent arcs can induce voltage into each others current paths that can be misinterpreted by the power sources, and result in arc interference.
- For longitudinal applications, connect all work leads at one end of the weldment, and all of the work voltage sense leads at the opposite end of the weldment. Perform welding in the direction away from the work leads and toward the sense leads.

(See Figure A.6)

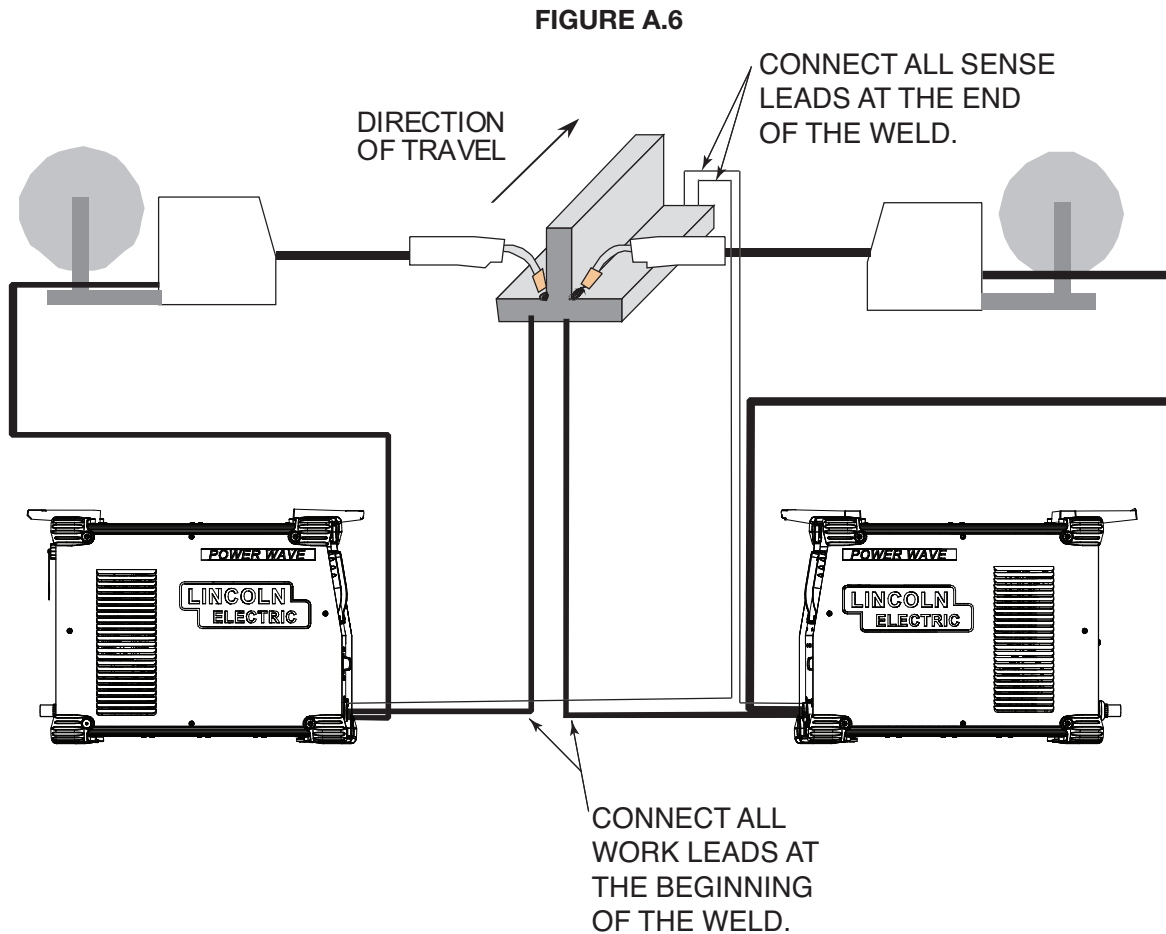

- **For circumferential applications**, connect all work leads on one side of the weld joint, and all of the work voltage sense leads on the opposite side, such that they are out of the current path.
(See Figure A.7)

FIGURE A.7

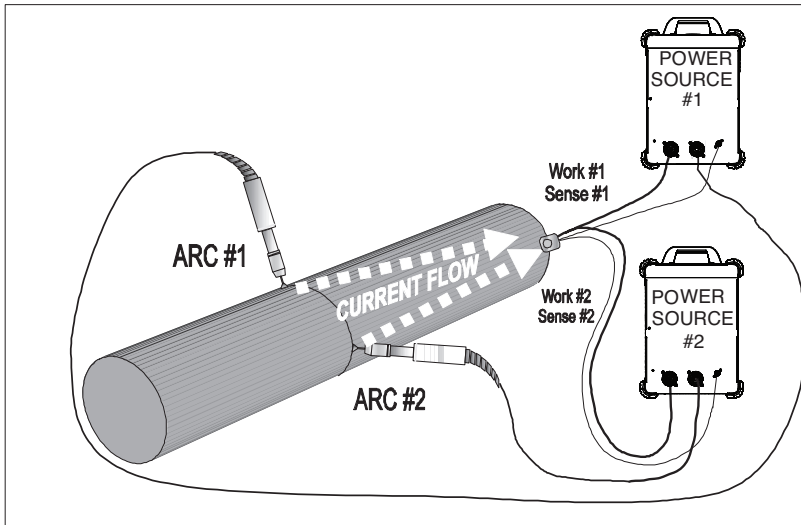

BAD

- CURRENT FLOW FROM ARC #1 AFFECTS SENSE LEAD #2
- CURRENT FLOW FROM ARC #2 AFFECTS SENSE LEAD #1
- NEITHER SENSE LEAD PICKS UP THE CORRECT WORK VOLTAGE, CAUSING STARTING AND WELDING ARC INSTABILITY

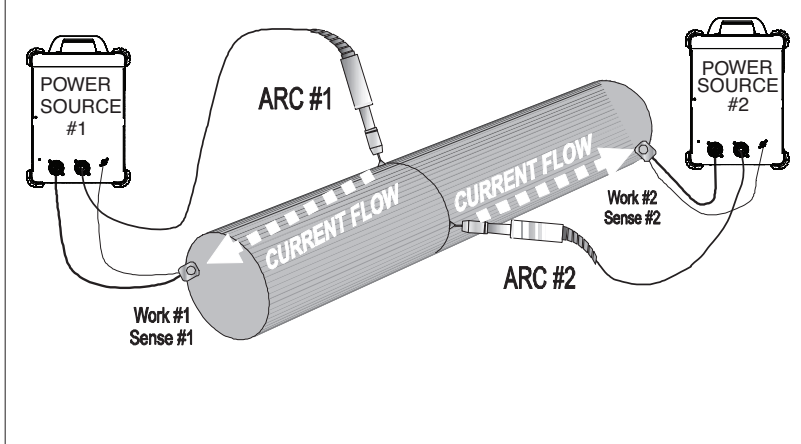

BETTER

- SENSE LEAD #1 IS ONLY AFFECTED BY CURRENT FLOW FROM ARC #1
- SENSE LEAD #2 IS ONLY AFFECTED BY CURRENT FLOW FROM ARC #2
- DUE TO VOLTAGE DROPS ACROSS THE WORKPIECE ARC VOLTAGE MAY BE LOW, CAUSING NEED FOR DEVIATION FROM STANDARD PROCEDURES

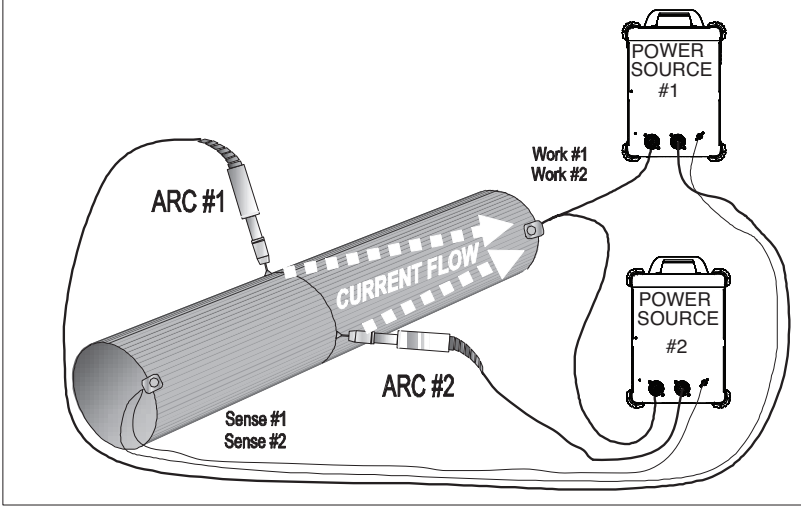

BEST

- BOTH SENSE LEADS ARE OUT OF THE CURRENT PATHS
- BOTH SENSE LEADS DETECT ARC VOLTAGE ACCURATELY
- NO VOLTAGE DROP BETWEEN ARC AND SENSE LEAD
- BEST STARTS, BEST ARCS, MOST RELIABLE RESULTS

CONTROL CABLE CONNECTIONS

General Guidelines

Genuine Lincoln control cables should be used at all times (except where noted otherwise). Lincoln cables are specifically designed for the communication and power needs of the Power Wave® / Power Feed™ systems. Most are designed to be connected end to end for ease of extension. Generally, it is recommended that the total length not exceed 100ft. (30.5m). The use of non-standard cables, especially in lengths greater than 25 feet, can lead to communication problems (system shutdowns), poor motor acceleration (poor arc starting), and low wire driving force (wire feeding problems). Always use the shortest length of control cable possible, and **DO NOT coil excess cable**.

Regarding cable placement, best results will be obtained when control cables are routed separate from the weld cables. This minimizes the possibility of interference between the high currents flowing through the weld cables, and the low level signals in the control cables. These recommendations apply to all communication cables including ArcLink® and Ethernet connections.

Product specific Installation Instructions

Connection Between Power Source and ArcLink® Compatible Wirefeeders (K1543, K2683 – ArcLink Control Cable)

The 5-pin ArcLink control cable connects the power source to the wire feeder. The control cable consists of two power leads, one twisted pair for digital communication, and one lead for voltage sensing. The 5-pin ArcLink connection on the Power Wave® R500 is located on the rear panel (See Case Back Controls in the **Operation Section**). The control cable is keyed and polarized to prevent improper connection. Best results will be obtained when control cables are routed separate from the weld cables, especially in long distance applications. The recommended combined length of the ArcLink control cable network should not exceed 200ft. (61.0m).

Connection Between Power Source and Ethernet Networks

The POWER WAVE® R500 is equipped with an IP67 rated ODVA compliant RJ-45 Ethernet connector, which is located on the rear panel. All external Ethernet equipment (cables, switches, etc.), as defined by the connection diagrams, must be supplied by the customer. It is critical that all Ethernet cables external to either a conduit or an enclosure are solid conductor, shielded cat 5e cable, with a drain. The drain should be grounded at the source of transmission. For best results, route Ethernet cables away from weld cables, wire drive control cables, or any other current carrying device that can create a fluctuating magnetic field. For additional guidelines refer to ISO/IEC 11801. Failure to follow these recommendations can result in an Ethernet connection failure during welding.

SAFETY PRECAUTIONS

READ AND UNDERSTAND ENTIRE SECTION BEFORE OPERATING MACHINE.

⚠ WARNING



- **ELECTRIC SHOCK CAN KILL.**
- Do not touch electrically live part or electrode with skin or wet clothing.
- Insulate yourself from work and ground.
- Always wear dry insulating gloves.
- Do not operate with covers, panels or guards removed or open.



- **FUMES AND GASSES** can be dangerous.
- Keep your head out of fumes.
- Use ventilation or exhaust to remove fumes from breathing zone.



- **WELDING SPARKS** can cause fire or explosion.
- Keep flammable material away.



- **ARC RAYS** can burn.
- Wear eye, ear and body protection.

SEE ADDITIONAL WARNING INFORMATION UNDER ARC WELDING SAFETY PRECAUTIONS AND IN THE FRONT OF THIS OPERATING MANUAL.

POWER-UP SEQUENCE

When the POWER WAVE® R500 is powered up, it can take as long as 30 seconds for the machine to be ready to weld. During this time period the user interface will not be active.

DUTY CYCLE

The duty cycle is based on a ten-minute period. A 40% duty cycle represents 4 minutes of welding and 6 minutes of idling in a ten-minute period. Refer to the technical specification section for the POWER WAVE® R500's duty cycle ratings.

GRAPHIC SYMBOLS THAT APPEAR ON THIS MACHINE OR IN THIS MANUAL



WARNING OR CAUTION



DANGEROUS VOLTAGE



POSITIVE OUTPUT



NEGATIVE OUTPUT



HIGH TEMPERATURE



STATUS



PROTECTIVE GROUND



COOLER



OUTPUT



OPERATORS MANUAL



WORK



CIRCUIT BREAKER

PRODUCT DESCRIPTION

PRODUCT SUMMARY

The POWER WAVE® R500 is a portable multi-process power source with high-end functionality capable of Stick, DC TIG, MIG, Pulsed MIG and Flux-Cored welding. It is ideal for a wide variety of materials including aluminum, stainless, and nickel — where arc performance is critical.

The POWER WAVE® R500 is designed to be a very flexible welding system. Like existing Power Wave's®, the software based architecture allows for future upgradeability. One significant change from the current range of Power Wave® units is that the Ethernet communication feature is standard on the POWER WAVE® R500 which allows for effortless software upgrades through Powerwavesoftware.com. The Ethernet communication also gives the POWER WAVE® R500 the ability to run Production Monitoring™ 2. A Devicenet option allows the POWER WAVE® R500 to be used in a wide range of configurations and the POWER WAVE® R500 is designed to be compatible with advanced welding modules like STT.

RECOMMENDED PROCESSES AND EQUIPMENT

The POWER WAVE® R500 is recommended for semiautomatic welding, and may also be suitable for basic hard automation applications. The POWER WAVE® R500 can be set up in a number of configurations, some requiring optional equipment or welding programs.

RECOMMENDED EQUIPMENT

The POWER WAVE® R500 is recommended for robotic and semiautomatic welding. The POWER WAVE® R500 can be set up in a number of configurations, some requiring optional equipment or welding programs.

RECOMMENDED PROCESSES

The POWER WAVE® R500 is a high speed, multi-process power source capable of regulating the current, voltage, or power of the welding arc. With an output range of 5 to 550 amperes, it supports a number of standard processes including synergic GMAW, GMAW-P, FCAW, FCAW-SS, SMAW, GTAW and GTAW-P on various materials especially steel, aluminum and stainless.

PROCESS LIMITATIONS

The software based weld tables of the POWER WAVE® R500 limit the process capability within the output range and the safe limits of the machine. In general the processes will be limited to .030-.052 solid steel wire, .030 -.045 stainless wire, .035 -1/16 cored wire, and .035 - 1/16 Aluminum wire.

EQUIPMENT LIMITATIONS

Only ArcLink compatible semiautomatic wire feeders and users interfaces may be used. If other Lincoln wire feeders or non-Lincoln wire feeders are used there will be limited process capability and performance and features will be limited.

DESIGN FEATURES

Loaded with Standard Features

- Multiple process DC output range: 5 - 550 Amps
- 380 – 600 VAC, 3 phase, 50-60Hz input power
- New and Improved Line Voltage Compensation holds the output constant over wide input voltage fluctuations.
- Utilizes next generation microprocessor control, based on the ArcLink® platform.
- State of the art power electronics technology yields superior welding capability.
- Electronic over current protection
- Input over voltage protection.
- F.A.N. (fan as needed). Cooling fan only runs when needed.
- Thermostatically protected for safety and reliability.
- Ethernet connectivity.
- Panel mounted Status and Thermal LED indicators facilitate quick and easy troubleshooting.
- Potted PC boards for enhanced ruggedness/reliability.
- Enclosure reinforced with heavy duty aluminum extrusions for mechanical toughness
- Waveform Control Technology™ for good weld appearance and low spatter, even when welding nickel alloys.
- Sync Tandem installed.

CASE FRONT CONTROLS

(See Figure B.1)

- 1. STATUS LED** - (See Troubleshooting Section for operational functions).
- 2. THERMAL LED** - Indicates when machine has thermal fault.

3. FEEDER STATUS LED - A two color LED that indicates system errors. The Power Wave R500 is equipped with two indicators. One is for the inverter power source, while the other indicates the status of the feeder control system. Normal operation is a steady green light. For more information and a detailed listing, see the troubleshooting section of this document or the Service Manual for this machine. **(See Troubleshooting Section for operational functions.)**

NOTE: The Power Wave R500 status light will flash green, and sometimes red and green, for up to one minute when the machine is first turned on. This is a normal situation as the machine goes through a self test at power up.

4. POWER SWITCH - Controls power to the POWER WAVE® R500.

5. NEGATIVE WELD OUTPUT

6. POSITIVE WELD OUTPUT

7. VOLTAGE SENSE CONNECTOR: Allows for separate remote electrode and work sense leads.

Pin	Lead	Function
3	21	Work Voltage Sense
1	67E	Electrode Voltage Sense

FIGURE B.1

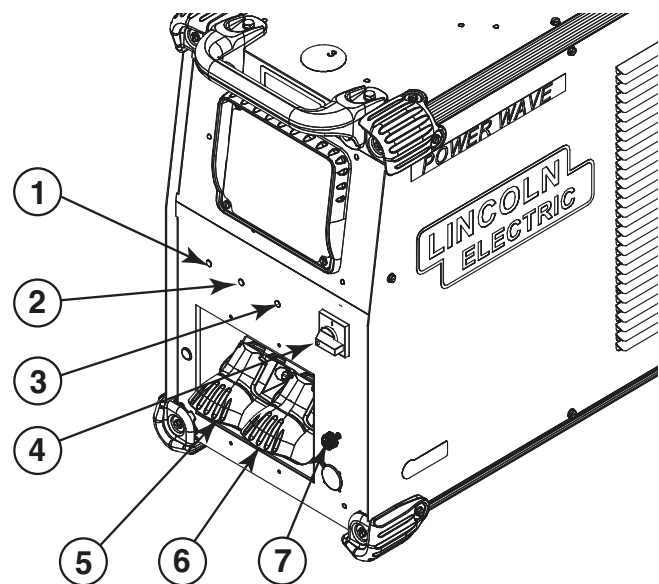

CASE BACK CONTROLS

(See Figure B.2)

1. 115 VAC CIRCUIT BREAKER
2. 115 VAC RECEPTACLES
3. WIRE FEEDER RECEPTACLE (14 PIN):
Robotic wire feeder connector (for 4R220, Power Feed 10 Robotic, etc).
4. DIFFERENTIAL I/O CONNECTOR:
For (Optional) K2902-2 STT or K2912-2 Advanced Module.
5. ARCLINK OUTPUT CONNECTOR (5 PIN):
Provides power and communication to ArcLink peripherals (semi-automatic feeder, Cool Arc 55S, etc).
6. DEVICENET KIT (OPTIONAL):
For PLC control.
7. 40V CIRCUIT BREAKER
8. ETHERNET (SHIELDED):
For ArcLink XT enabled robot, computer or network connection.

9. EXTERNAL I/O CONNECTOR:

Terminal Strip for making simple input signal connections. (See Figure B.2A)

The terminal strip is divided into three groups:

Group #1 - **TRIGGER**

Group #2 - **FEED FORWARD/REVERSE**

Group #3 - **SHUTDOWN INPUTS**

All inputs use "normally open" logic except the shutdown group. The shutdown inputs use "normally closed" logic, and are always enabled. Unused shutdowns must be tied to the +15V supply for the shutdown group. Machines are shipped from the factory with jumpers installed on both shutdown inputs.

Shutdown 1 and shutdown 2 inputs are for weld system faults and should not be used as emergency or safety shutdowns.

FIGURE B.2A

Shutdown 2 Input	Shutdown 1 Input	+15VDC - Group #3	Gas Purge	Feed Reverse	Feed Forward	+15VDC - Group #2	2/4 Step	Dual Procedure	Trigger	+15VDC - Group #1	
12	11	10	9	8	7	6	5	4	3	2	1

FIGURE B.2

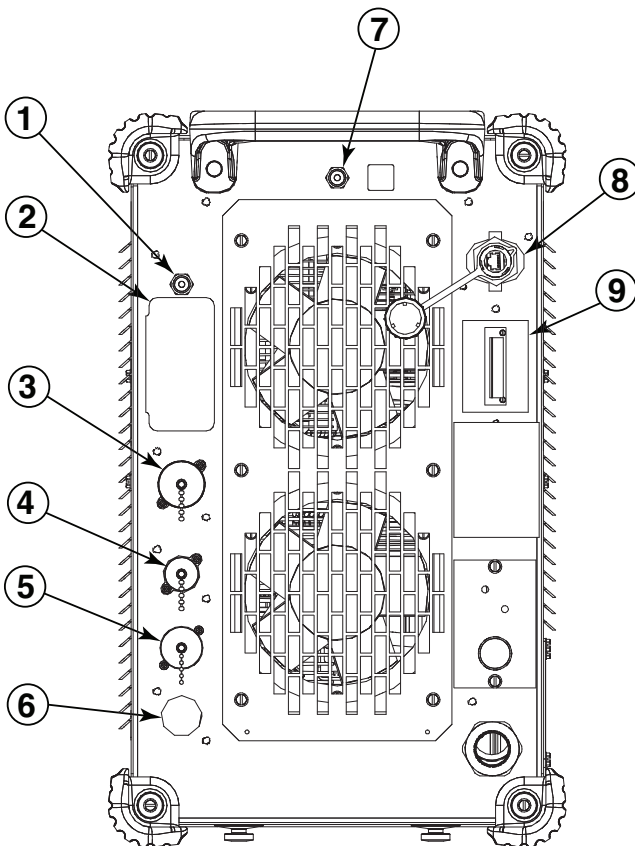

COMMON WELDING PROCEDURES

WARNING

MAKING A WELD

The serviceability of a product or structure utilizing the welding programs is and must be the sole responsibility of the builder/user. Many variables beyond the control of The Lincoln Electric Company affect the results obtained in applying these programs. These variables include, but are not limited to, welding procedure, plate chemistry and temperature, weldment design, fabrication methods and service requirements. The available range of a welding program may not be suitable for all applications, and the build/user is and must be solely responsible for welding program selection.

Choose the electrode material, electrode size, shielding gas, and process (GMAW, GMAW-P etc.) appropriate for the material to be welded.

Select the weld mode that best matches the desired welding process. The standard weld set shipped with the POWER WAVE® R500 encompasses a wide range of common processes that will meet most needs. If a special weld mode is desired, contact the local Lincoln Electric sales representative.

All adjustments are made through the user interface. Because of the different configuration options your system may not have all of the following adjustments.

See Accessories Section for Kits and Options available to use with the POWER WAVE® R500.

DEFINITION OF WELDING MODES

NON-SYNERGIC WELDING MODES

- A **Non-synergic** welding mode requires all welding process variables to be set by the operator.

SYNERGIC WELDING MODES

- A **Synergic** welding mode offers the simplicity of single knob control. The machine will select the correct voltage and amperage based on the Wire Feed Speed (WFS) set by the operator.

BASIC WELDING CONTROLS

Weld Mode

Selecting a weld mode determines the output characteristics of the Power Wave® power source. Weld modes are developed with a specific electrode material, electrode size, and shielding gas. For a more complete description of the weld modes programmed into the POWER WAVE® R500 at the factory, refer to the Weld Set Reference Guide supplied with the machine or available at www.powerwavesoftware.com.

Wire Feed Speed (WFS)

In synergic welding modes (synergic CV, GMAW-P), WFS is the dominant control parameter. The user adjusts WFS according to factors such as wire size, penetration requirements, heat input, etc. The POWER WAVE® R500 then uses the WFS setting to adjust the voltage and current according to settings contained in the POWER WAVE®.

In non-synergic modes, the WFS control behaves like a conventional power source where WFS and voltage are independent adjustments. Therefore, to maintain proper arc characteristics, the operator must adjust the voltage to compensate for any changes made to the WFS.

Amps

In constant current modes, this control adjusts the welding amperage.

Volts

In constant voltage modes, this control adjusts the welding voltage.

Trim

In pulse synergic welding modes, the Trim setting adjusts the arc length. Trim is adjustable from 0.50 to 1.50. 1.00 is the nominal setting and is a good starting point for most conditions.

UltimArc™ Control

UltimArc™ Control allows the operator to vary the arc characteristics. UltimArc™ Control is adjustable from -10.0 to +10.0 with a nominal setting of 0.0.

SMAW (STICK) WELDING

The welding current and Arc Force settings can be set through a Power Feed™ 10M or Power Feed™ 25M wire feeder. Alternatively an optional Stick / TIG UI can be installed into the power source to control these settings locally.

In a **SMAW** (STICK mode), Arc Force can be adjusted. It can be set to the lower range for a soft and less penetrating arc characteristic (negative numeric values) or to the higher range (positive numeric values) for a crisp and more penetrating arc. Normally, when welding with cellulosic types of electrodes (E6010, E7010, E6011), a higher energy arc is required to maintain arc stability. This is usually indicated when the electrode sticks to the workpiece or when the arc becomes unstable during manipulative technique. For low hydrogen types of electrodes (E7018, E8018, E9018, etc.) a softer arc is usually desirable and the lower end of the Arc Control suits these types of electrodes. In either case the arc control is available to increase or decrease the energy level delivered to the arc.

GTAW (TIG) WELDING

The welding current can be set through a Power Feed™ 10M or Power Feed™ 25M wire feeder. Alternatively an optional Stick / TIG UI can be installed into the power source to control these settings locally.

The **TIG** mode features continuous control from 5 to 550 amps with the use of an optional foot amptrol. The POWER WAVE® R500 can be run in either a Touch Start TIG mode or Scratch start TIG mode.

CONSTANT VOLTAGE WELDING

Synergic CV

For each wire feed speed, a corresponding voltage is preprogrammed into the machine through special software at the factory.

The nominal preprogrammed voltage is the best average voltage for a given wire feed speed, but may be adjusted to preference. When the wire feed speed changes, the POWER WAVE® R500 automatically adjusts the voltage level correspondingly to maintain similar arc characteristics throughout the WFS range.

Non Synergic CV

In non-synergic modes, the WFS control behaves more like a conventional CV power source where WFS and voltage are independent adjustments. Therefore to maintain the arc characteristics, the operator must adjust the voltage to compensate for any changes made to the WFS.

All CV Modes

Pinch adjusts the apparent inductance of the wave shape. The “pinch” function is inversely proportional to inductance. Therefore, increasing Pinch Control greater than 0.0 results in a crisper arc (more spatter) while decreasing the Pinch Control to less than 0.0 provides a softer arc (less spatter).

PULSE WELDING

Pulse welding procedures are set by controlling an overall “arc length” variable. When pulse welding, the arc voltage is highly dependent upon the waveform. The peak current, back ground current, rise time, fall time and pulse frequency all affect the voltage. The exact voltage for a given wire feed speed can only be predicted when all the pulsing waveform parameters are known. Voltage or Trim can be adjusted.

Trim adjusts the arc length and ranges from 0.50 to 1.50 with a nominal value of 1.00. Trim values greater than 1.00 increase the arc length, while values less than 1.00 decrease the arc length. (See figure B.3)

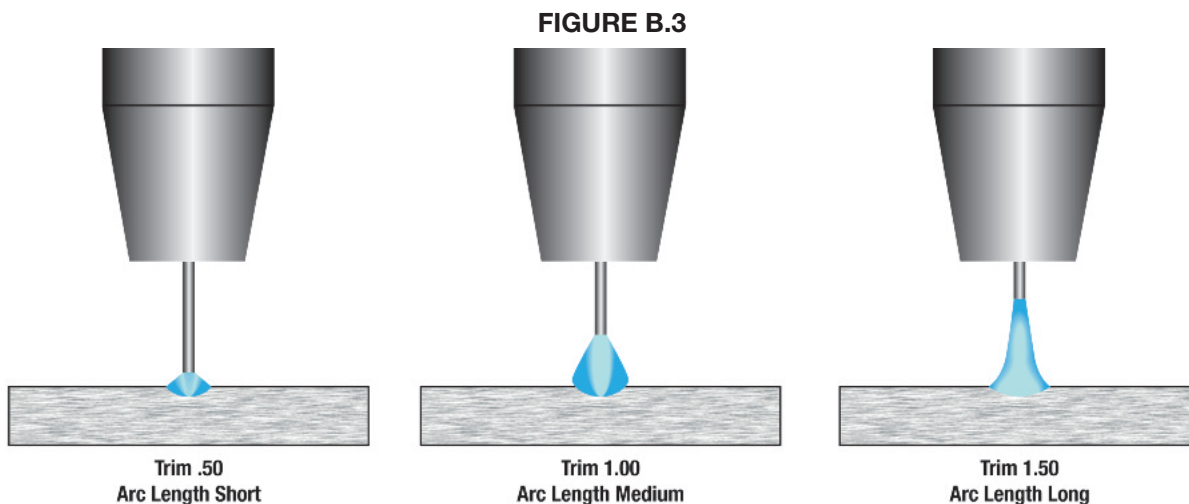

Most pulse welding programs are synergic. As the wire feed speed is adjusted, the POWER WAVE® R500 will automatically recalculate the waveform parameters to maintain similar arc properties.

The POWER WAVE® R500 utilizes “adaptive control” to compensate for changes in the electrical stick-out while welding. (Electrical stick-out is the distance from the contact tip to the work piece.) The POWER WAVE® R500 waveforms are optimized for a 0.75” stick-out. The adaptive behavior supports a range of stick-outs from 0.50 to 1.25”. At very low or high wire feed speeds, the adaptive range may be less due to reaching physical limitations of the welding process.

UltimArc™ Control adjusts the focus or shape of the arc. UltimArc™ Control is adjustable from -10.0 to +10.0 with a nominal setting of 0.0. Increasing the UltimArc™ Control increases the pulse frequency and background current while decreasing the peak current. This results in a tight, stiff arc used for high speed sheet metal welding. Decreasing the UltimArc™ Control decreases the pulse frequency and background current while increasing the peak current. This results in a soft arc good for out of position welding. (See Figure B.4)

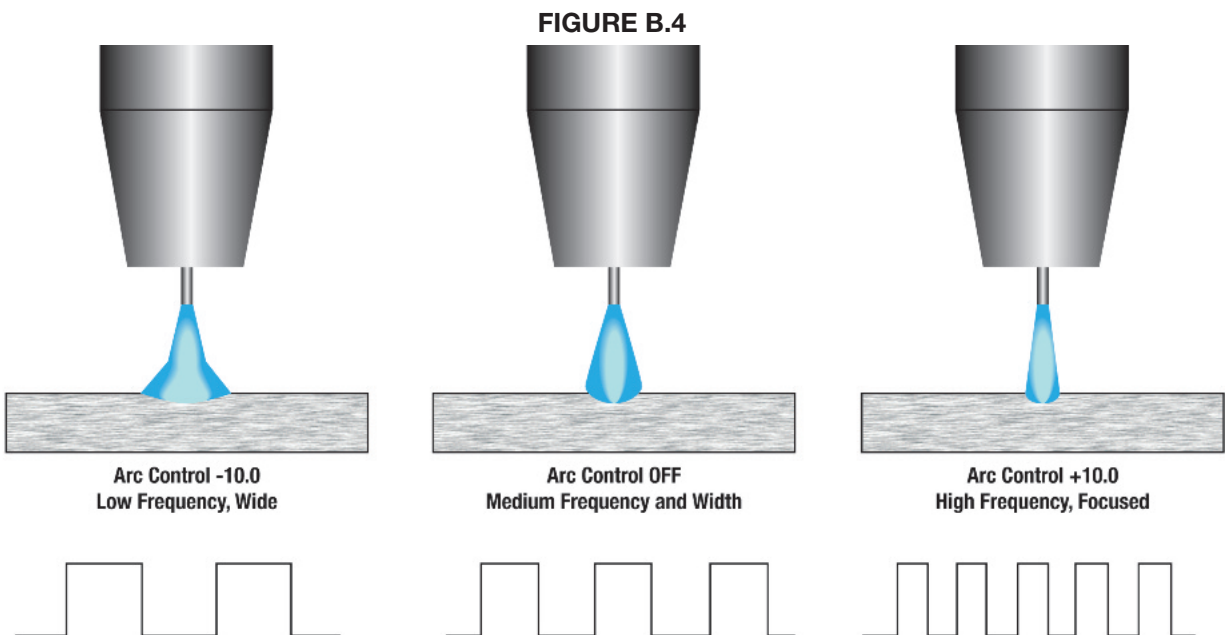

KITS, OPTIONS AND ACCESSORIES

All Kits Options and Accessories are found on the Web site:
(www.lincolnelectric.com)

FACTORY INSTALLED

None Available

FIELD INSTALLED OPTIONS

GENERAL OPTIONS

DeviceNet Kit

Mounts inside the back of the POWER WAVE® R500. Allows Devicenet objects to communicate with the POWER WAVE® R500.

Order K2827-1

Work Voltage Sense Lead Kit

Required to accurately monitor voltage at the arc.

Order K940-XX Series

Order K1811-XX Series

Deluxe Adjustable Gas Regulator & Hose Kit

Accommodates CO₂, Argon, or Argon-blend gas cylinders. Includes a cylinder pressure gauge, dual scale flow gauge and 4.3 ft. (1.3 m) gas hose.

Order K586-1

K2149-1 Work Lead Package



K1842-10 10ft. Weld Power Cable

Coaxial Welding Cable

Optimum weld cables for minimizing cable inductance and optimizing welding performance.

AWG 1/0 Coaxial Cables:

Order K1796-25 for 25 feet (7.6 m) cable length.

Order K1796-50 for 50 feet (15.2 m) cable length.

Order K1796-75 for 75 feet (22.9 m) cable length.

Order K1796-100 for 100 feet (30.5 m) cable length.

AWG #1 Coaxial Cables:

Order K2593-25 for 25 feet (7.6 m) cable length.

Order K2593-50 for 50 feet (15.2 m) cable length.

Order K2593-100 for 100 feet (30.5 m) cable length.

Welding Fume Extractors

Lincoln offers a wide range of fume extraction environmental system solutions, ranging from portable systems easily wheeled around a shop to shop-wide central systems servicing many dedicated welding stations.

Request Lincoln publication E13.40

(See www.lincolnelectric.com)

SAFETY PRECAUTIONS

⚠ WARNING

ELECTRIC SHOCK can kill.



- Do not operate with covers removed.
 - Turn off power source before installing or servicing.
 - Do not touch electrically hot parts.
 - Turn the input power to the welding power source off at the fuse box before working in the terminal strip.
 - Only qualified personnel should install, use or service this equipment.
-

ROUTINE MAINTENANCE

Routine maintenance consists of periodically blowing out the machine, using a low-pressure air stream, to remove accumulated dust and dirt from the intake and outlet louvers, and the cooling channels in the machine.

PERIODIC MAINTENANCE

Calibration of the POWER WAVE® R500 is critical to its operation. Generally speaking the calibration will not need adjustment. However, neglected or improperly calibrated machines may not yield satisfactory weld performance. To ensure optimal performance, the calibration of output Voltage and Current should be checked yearly.

CALIBRATION SPECIFICATION

Output Voltage and Current are calibrated at the factory. Generally the machine calibration will not need adjustment. However, if the weld performance changes, or the yearly calibration check reveals a problem, use the calibration section of the **Diagnostics Utility** to make the appropriate adjustments.

The calibration procedure itself requires the use of a grid, and certified actual meters for voltage and current. The accuracy of the calibration will be directly affected by the accuracy of the measuring equipment you use. The **Diagnostics Utility** includes detailed instructions, and is available on the **Service Navigator CD** or at www.powerwavesoftware.com.

HOW TO USE TROUBLESHOOTING GUIDE

WARNING

Service and Repair should only be performed by Lincoln Electric Factory Trained Personnel. Unauthorized repairs performed on this equipment may result in danger to the technician and machine operator and will invalidate your factory warranty. For your safety and to avoid Electrical Shock, please observe all safety notes and precautions detailed throughout this manual.

This Troubleshooting Guide is provided to help you locate and repair possible machine malfunctions. Simply follow the three-step procedure listed below.

Step 1. LOCATE PROBLEM (SYMPTOM).

Look under the column labeled "PROBLEM (SYMPTOMS)". This column describes possible symptoms that the machine may exhibit. Find the listing that best describes the symptom that the machine is exhibiting.

Step 2. POSSIBLE CAUSE.

The second column labeled "POSSIBLE CAUSE" lists the obvious external possibilities that may contribute to the machine symptom.

Step 3. RECOMMENDED COURSE OF ACTION

This column provides a course of action for the Possible Cause, generally it states to contact your local Lincoln Authorized Field Service Facility.

If you do not understand or are unable to perform the Recommended Course of Action safely, contact your local Lincoln Authorized Field Service Facility.

WARNING



ELECTRIC SHOCK can kill.

- Turn the input power OFF at the welding power source before installation or changing drive rolls and/or guides.
- Do not touch electrically live parts.
- When inching with the gun trigger, electrode and drive mechanism are "hot" to work and ground and could remain energized several seconds after the gun trigger is released.
- Welding power source must be connected to system ground per the National Electrical Code or any applicable local codes.
- Only qualified personnel should perform maintenance work.

Observe all additional Safety Guidelines detailed throughout this manual.

CAUTION

If for any reason you do not understand the test procedures or are unable to perform the tests/repairs safely, contact your **Local Lincoln Authorized Field Service Facility** for technical troubleshooting assistance before you proceed.

USING THE STATUS LED TO TROUBLESHOOT SYSTEM PROBLEMS

Not all of the POWER WAVE® R500 errors will be displayed on the user interface (if it is installed). There are two status lights that display error codes. If a problem occurs it is important to note the condition of the status lights. **Therefore, prior to cycling power to the system, check the power source status light for error sequences as noted below.**

There is one externally mounted status light located on the case front of the machine. This status light corresponds to the main control board and input control board's status.

basic troubleshooting charts for both machine and weld performance.

The status light for the main control board and input control board are dual-color LED's. Normal operation for each is steady green.

Error conditions are indicated in the following chart Table E.1.

Included in this section is information about the Status Lights and some

TABLE E.1

Light Condition	Meaning
	Main control board status light and Input control board
Steady Green	System OK. Power source is operational, and is communicating normally with all healthy peripheral equipment connected to its ArcLink network.
Blinking Green	Occurs during power up or a system reset, and indicates the POWER WAVE® R500 is mapping (identifying) each component in the system. Normal for first 1-10 seconds after power is turned on, or if the system configuration is changed during operation.
Fast Blinking Green	Indicates Auto-mapping has failed
Alternating Green and Red	Non-recoverable system fault. If the Status lights are flashing any combination of red and green, errors are present. Read the error code(s) before the machine is turned off.
	Error Code interpretation through the Status light is detailed in the Service Manual. Individual code digits are flashed in red with a long pause between digits. If more than one code is present, the codes will be separated by a green light. Only active error conditions will be accessible through the Status Light.
	Error codes can also be retrieved with the Power Wave Manager Utility available at www.powerwavesoftware.com). This is the preferred method, since it can access historical information contained in the error logs.
	To clear the active error(s), turn power source off, and back on to reset.
Steady Red	Not applicable.
Blinking Red	Not applicable.
Status LED off	Not applicable.

⚠ CAUTION

If for any reason you do not understand the test procedures or are unable to perform the tests/repairs safely, contact your **Local Lincoln Authorized Field Service Facility** for technical troubleshooting assistance before you proceed.

Observe all Safety Guidelines detailed throughout this manual

ERROR CODES FOR THE POWER WAVE® R500

The following is a partial list of possible error codes for the POWER WAVE® R500. For a complete listing consult the Service Manual for this machine.

MAIN CONTROL BOARD ("STATUS" LIGHT)	
Error Code #	Indication
36 Thermal error	Indicates over temperature. Usually accompanied by Thermal LED. Check fan operation. Be sure process does not exceed duty cycle limit of the machine
54 Secondary (Output) over current error	The long term average secondary (weld) current limit has been exceeded. NOTE: The long term average secondary current limit is 325A (1 Phase) or 575A (3 Phase).
56 Chopper communication error	Indicates communication link between main control board and chopper has errors. If cycling the input power on the machine does not clear the error, contact the Service Department.
58 Primary Fault error	Review error code from input board status light or status beeper. Most likely caused by an over power condition which caused an under voltage on the primary bus. If cycling the input power on the machine does not clear the error, contact the Service Department.
71 Secondary (Output) over power error	The long term secondary (Weld) power limit has been exceeded. NOTE: The long term average secondary current limit is 25kw (3 Phase), 14kw (1 Phase).
Other	Error codes that contain three or four digits are defined as fatal errors. These codes generally indicate internal errors on the Power Source Control Board. If cycling the input power on the machine does not clear the error, contact the Service Department.

CAUTION

If for any reason you do not understand the test procedures or are unable to perform the tests/repairs safely, contact your **Local Lincoln Authorized Field Service Facility** for technical troubleshooting assistance before you proceed.

Observe all Safety Guidelines detailed throughout this manual

INPUT CONTROL BOARD

Error Code #	Indication	Type
331 Instantaneous Input Current Limit	Instantaneous input current limit has been exceeded. Typically indicates short term power overload. If problem persists contact Service Department.	Persistent
334 Startup Current Check Failure	Input current limit was exceeded during machine power-up. If problem persists contact Service Department.	Persistent
335 Startup Voltage Check Failure	Input voltage was too high or too low during machine power-up. Verify that the input voltage is between 200V and 650V.	Temporary
336 Thermal Fault	Thermostat on primary module tripped. Typically caused by a fan malfunction or blocked air vent.	Temporary
337 Precharge Timeout	The DC bus voltage was not charged to a certain level at end of precharge. If problem persists contact Service Department.	Persistent
338 Input Power Limit	The input power drawn by the machine exceeded a safe level. If problem persists, contact the Service Department.	Persistent
341 Input Voltage Dropout	The input voltage momentarily dropped out. Check connections and verify quality of input power.	Temporary
346 Transformer Primary Overcurrent	Transformer current too high. Typically indicates short-term power overload. If problem persists, contact the Service Department.	Persistent
347 Average Input Current Limit	Average input current limit has been exceeded. Typically indicates short term power overload. If problem persists contact Service Department.	Persistent
349 Bus Undervoltage	The DC bus voltage dropped below the allowable limit. If problem persists, contact the Service Department.	Temporary

Persistent errors require power to be cycled for the error to clear.

Temporary faults will go away on their own if the error condition is removed.

WIRE DRIVE MODULE

Error Code #	Indication
81 Motor Overload	Long term average motor current limit has been exceeded. Typically indicates mechanical overload of system. If problem continues consider higher torque gear ratio (lower speed range).
82 Motor Overcurrent	Absolute maximum motor current level has been exceeded. This is a short term average to protect drive circuitry.
83 Shutdown #1 Is Open	1.This refers to the 'green' I/O connector on the bottom of the controller. If not being externally accessed, verify the integrity of the connector and jumper. If accessed through a remote circuit, verify the integrity of that circuit.
84 Shutdown #2 Is Open	1.This refers to the 'green' I/O connector on the bottom of the controller. If not being externally accessed, verify the integrity of the connector and jumper. If accessed through a remote circuit, verify the integrity of that circuit.

CAUTION

If for any reason you do not understand the test procedures or are unable to perform the tests/repairs safely, contact your **Local Lincoln Authorized Field Service Facility** for technical troubleshooting assistance before you proceed.

Observe all Safety Guidelines detailed throughout this manual

PROBLEMS (SYMPTOMS)	POSSIBLE CAUSE	RECOMMENDED COURSE OF ACTION
Basic Machine Problems		
Input fuses keep blowing	1. Improperly sized input fuses.	1. Make sure fuses are properly sized. See installation section of this manual for recommended sizes.
	2. Improper Weld Procedure requiring output levels in excess of machine rating.	2. Reduce output current, duty cycle, or both.
	3. Major physical or electrical damage is evident when the covers are removed.	3. Contact your local authorized Lincoln Electric Field Service facility for technical assistance.
Machine will not power up (no lights)	1. No Input Power	1. Make sure input supply disconnect has been turned ON. Check input fuses. Make certain that the Power Switch (SW1) on the power source is in the "ON" position.
	2. Input voltage is too low or too high.	2. Make certain that input voltage is correct, according to the Rating Plate located on the rear of the machine.
Machine won't weld, can't get any output. This problem will normally be accompanied by an error code. See "Status Light" section of this document for additional information.	1. Input voltage is too low or too high.	1. Make certain that input voltage is correct, according to the Rating Plate located on the rear of the machine.
	2. Thermal Error.	2. See "Thermal LED is ON" section.
	3. Secondary current limit has been exceeded. (see error 54)	3. Possible short in output circuit. If condition persists, contact an authorized Lincoln Electric Field Service facility.
	3a. Input control board fault (see input control board error status).	

⚠ CAUTION

If for any reason you do not understand the test procedures or are unable to perform the tests/repairs safely, contact your **Local Lincoln Authorized Field Service Facility** for technical troubleshooting assistance before you proceed.

Observe all Safety Guidelines detailed throughout this manual

PROBLEMS (SYMPTOMS)	POSSIBLE CAUSE	RECOMMENDED COURSE OF ACTION
Basic Machine Problems (Continued)		
Thermal LED is ON	1. Improper fan operation.	1. Check for proper fan operation. Fan should run in a low speed setting when the machine is idle and in a high speed when the output is triggered. Check for material blocking intake or exhaust louvers, or for excessive dirt clogging cooling channels in machine.
	2. Open thermostat circuit.	2. Check for broken wires, open connections or faulty thermostats in the thermostat circuit.
"Real Time Clock" no longer functioning	1. Control PC Board Battery.	1. Replace the battery (Type: BS2032)
Weld and Arc Quality Problems		
General degradation of weld performance	1. Wire feed problem.	1. Check for feeding problems.
	2. Cabling problems.	2. Check for bad connections, excessive loops in cable, etc. NOTE: The presence of heat in the external welding circuit indicates poor connections or undersized cables.
	3. Loss of, or improper Shielding Gas.	3. Verify gas flow and type are correct.
	4. Verify weld mode is correct for process.	4. Select the correct weld mode for the application.
	5. Machine calibration.	5. The power source may require calibration. (current, voltage, WFS).

⚠ CAUTION

If for any reason you do not understand the test procedures or are unable to perform the tests/repairs safely, contact your **Local Lincoln Authorized Field Service Facility** for technical troubleshooting assistance before you proceed.

Observe all Safety Guidelines detailed throughout this manual

PROBLEMS (SYMPTOMS)	POSSIBLE CAUSE	RECOMMENDED COURSE OF ACTION
Weld and Arc Quality Problems (Continued)		
Wire burns back to tip at the end of the weld.	1. Burnback Time	1. Reduce burnback time and/or work point.
Machine output shuts down during a weld.	1. Secondary current limit has been exceeded, and the machine shuts down to protect itself.	1. Adjust procedure or reduce load to lower current draw from the machine.
	2. System Fault	2. A non-recoverable fault will interrupt welding. This condition will also result in a status light blinking. See the Status Light section for more information.
Machine won't produce full output.	1. Input voltage may be too low, limiting output capability of the power source.	1. Make certain that the input voltage is proper, according to the Rating Plate located on the rear of the machine.
	2. The input may be single phase.	2. Verify all 3 phases are present.
	3. Machine calibration.	3. Calibrate secondary current and voltage.
Excessively long and erratic arc.	1. Wire feed problem.	1. Check for feeding problems. Make sure proper gear ratio has been selected.
	2. Loss of, or improper Shielding Gas	2. Verify gas flow and type are correct
	3. Machine calibration.	3. Calibrate secondary current and voltage.

⚠ CAUTION

If for any reason you do not understand the test procedures or are unable to perform the tests/repairs safely, contact your **Local Lincoln Authorized Field Service Facility** for technical troubleshooting assistance before you proceed.

Observe all Safety Guidelines detailed throughout this manual

PROBLEMS (SYMPTOMS)	POSSIBLE CAUSE	RECOMMENDED COURSE OF ACTION
Ethernet		
Cannot Connect	1. Physical connection.	1. Verify that the correct patch cable or cross over cable is being used (refer to local IT department for assistance). 1a. Verify the cables are fully inserted into the bulk head connector. 1b. The LED under the PC board ethernet connector will be lit when the machine is connected to another network device.
	2. IP address information.	2. Use the appropriate PC utility to verify the correct IP address information has been entered. 2a. Verify no duplicate the IP addresses exist on the network.
	3. Ethernet Speed	3. Verify that the network device connected to the Power Wave is either a 10-baseT device or a 10/100-baseT device.
Connection Drops while welding	1. Cable Location	1. Verify Network cable is not located next to current carrying conductors. This would include input power cables and welding output cables.

⚠ CAUTION

If for any reason you do not understand the test procedures or are unable to perform the tests/repairs safely, contact your **Local Lincoln Authorized Field Service Facility** for technical troubleshooting assistance before you proceed.

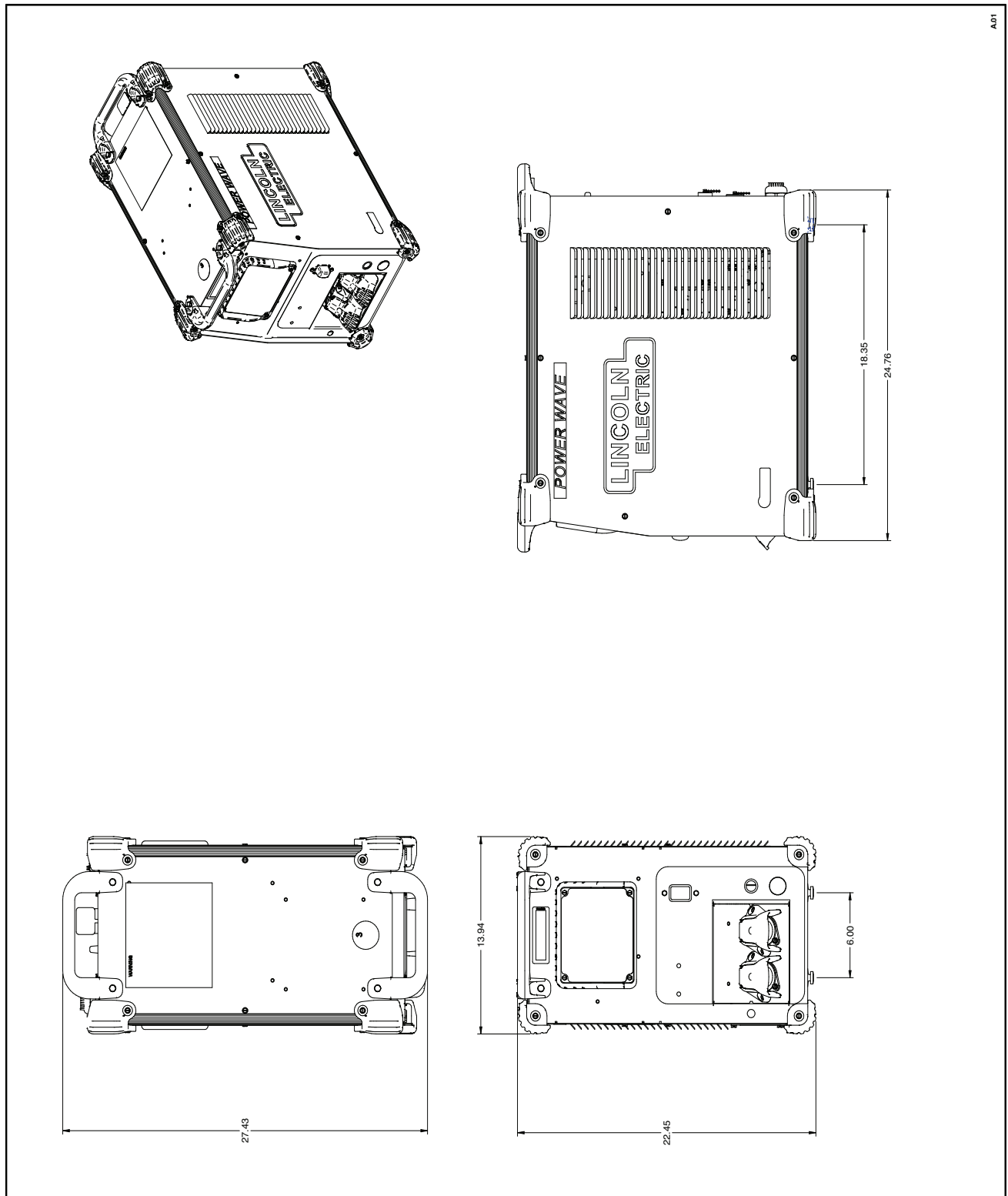

A01
L16215

Index of Sub Assemblies - 12483

KEY	PART NUMBER	DESCRIPTION	QTY
	P-885-A	Index of Sub Assemblies	AR
1	P-885-C	Case Front Assembly	AR
2	P-885-D	Base & Power Conversion Assembly	AR
3	P-885-E	Case Back Assembly	AR
4	P-885-F	Roof Assembly	AR

Index of Sub Assemblies - 12483

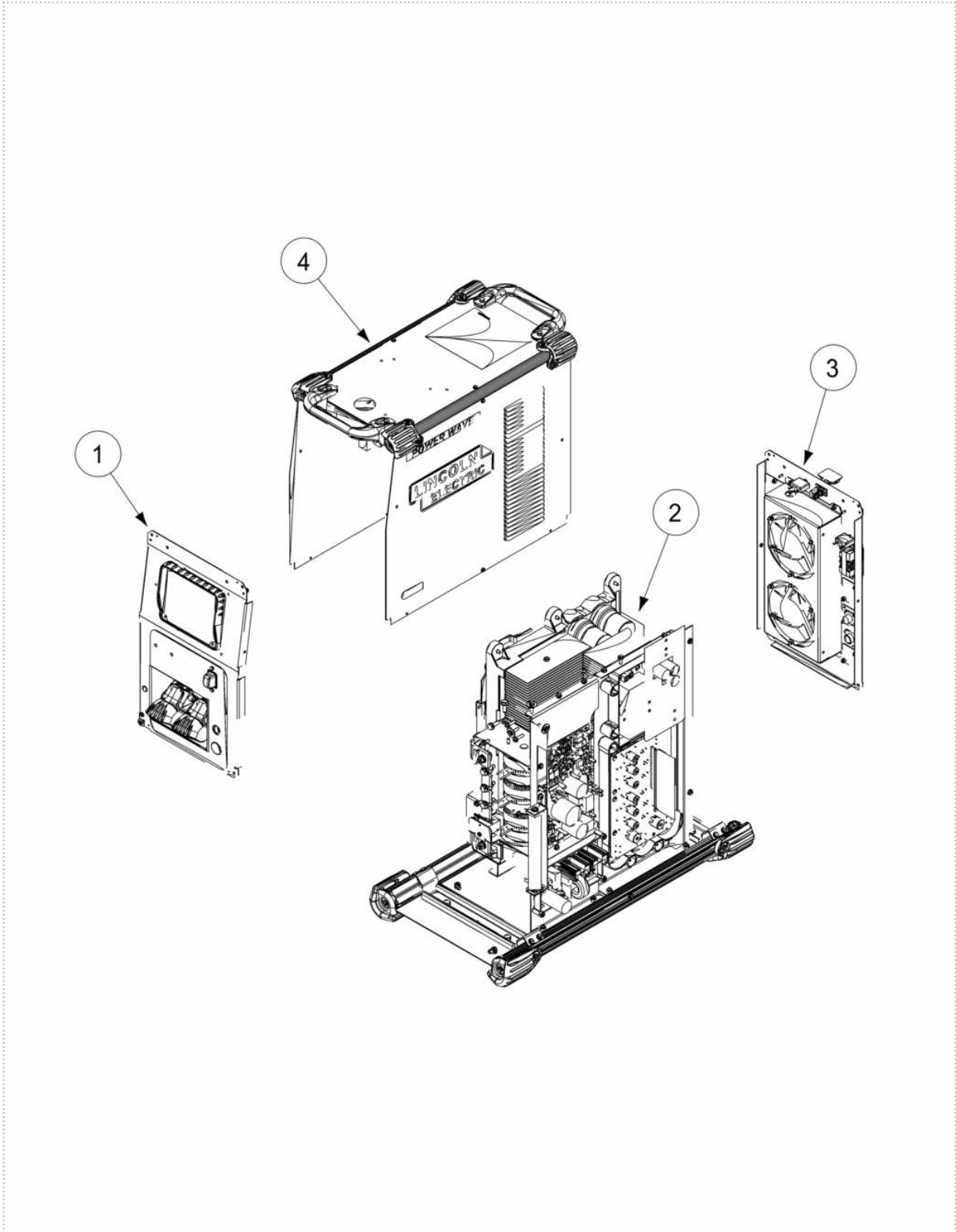

P-885-A.jpg

Case Front Assembly

KEY	PART NUMBER	DESCRIPTION	QTY
	9SG7162-6	Case Front Assembly	1
1	9SG7110-1	Case Front	1
	9SM22487-1	LED HARNESS	1
	9SS23740-2	LED PANEL MOUNT ASSEMBLY	2
2B	9ST13657-4FA	YELLOW LED	1
2C	9ST13657-7H24	LED-T-1 3/4BI-COLORRED/GREEN	1
2D	9SS23093-1	LED LENS CLEAR	2
2E	9SS23094-1	RETAINING O RING	2
3A	9SM22764	PFC BRACKET	1
16B	9ST9187-13	#10-24HLN-1817/1-NYLON INSERT	4
5A	9SS29541-2	Line Switch	1
14A	9SS16656-4	OUTPUT TERMINAL ASBLY	2
	9SS9225-99	SELF TAPPING SCREW	4
	9ST3960	FLANGE NUT	2
15A	9SM20305-1	NOISE SUPPRESSOR PC BD ASBLY	1
15B	9SS28402-1	NOISE SUPPRESSOR BRACKET	1
16B	9ST9187-13	#10-24HLN-1817/1-NYLON INSERT	4
16A	9SS28805-8	PFC CONTROL BOARD ASBLY	1
16B	9ST9187-13	#10-24HLN-1817/1-NYLON INSERT	4
17A	9SG6864	OUTPUT STUD COVER	2
	9SS9262-184	WASHER	4
	9SS9225-100	SELF TAPPING SCREW	4
19	9SG8555	Nameplate	1
20	9ST10397-23	PLUG BUTTON	1
22	9ST10397-3	PLUG BUTTON	1
24	9SS18657	SQUARE FLANGE FEMALE RECEPTACLE	1
	9SS9262-80	PLAIN WASHER	1
	9SE106A-15	LOCKWASHER	1
25C	9SCF000021	1/2-13X1.00HHCS	1
	9SS9262-80	PLAIN WASHER	1
	9SE106A-15	LOCKWASHER	1
26C	9SCF000030	1/2-13X1.25HHCS	1
	9SS9225-99	SELF TAPPING SCREW	4
31A	9SL15069	COVER PLATE	1

Case Front Assembly

KEY	PART NUMBER	DESCRIPTION	QTY
	9SS9225-99	SELF TAPPING SCREW	4
31C	9SG6529	UI TRIM	1
31D	9SG6601-1	DECAL - UI COVER PLATE	1

Case Front Assembly

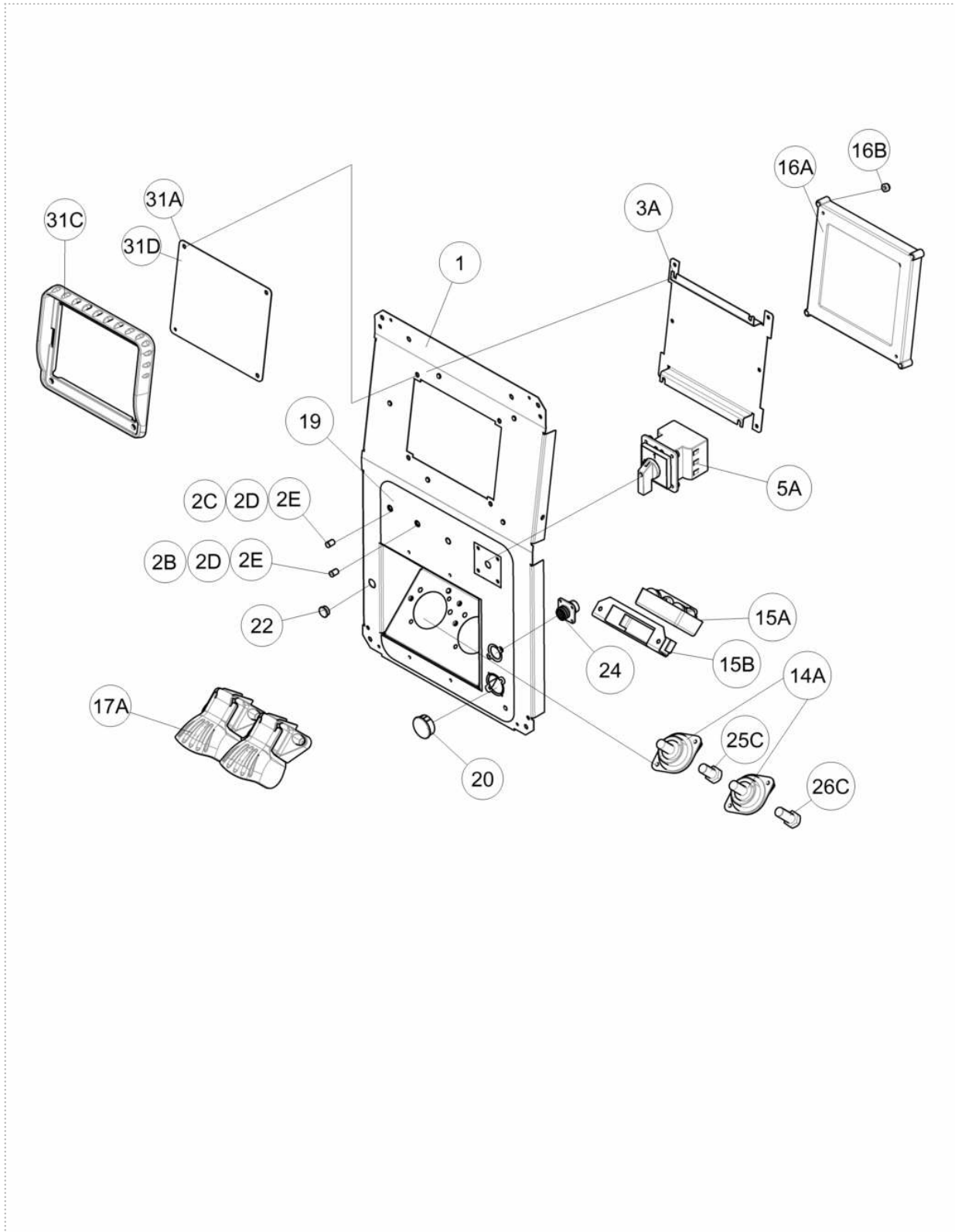

P-885-C.jpg

Base & Power Conversion Assembly

KEY	PART NUMBER	DESCRIPTION	QTY
	9SG7164-6	Base Assembly	1
1A	9SL15254	BASE	1
	9SS9225-99	SELF TAPPING SCREW	5
2	9SM21251-2	BASE EXTRUSION	2
3A	9SL15091	BRACKET	2
	9SS9225-99	SELF TAPPING SCREW	5
	9ST9695-1	LOCKWASHER	1
4A	9SS28070	QUICK LOCK FOOT	4
	9SCF000013	1/4-20X.625HHCS	1
	9SE106A-2	LOCKWASHER	4
8A	9SL13138	CORNER CAP	4
8B	9SS9262-182	PLAIN WASHER	8
8C	9SS9225-100	SELF TAPPING SCREW	8
	9SL16052	TOP EXTRUSION ASSEMBLY	1
9A	9SG7151	FRONT DIVIDER ASBLY	1
9B	9SL13270-4	OUTPUT CHOKE ASBLY	1
	9SS9225-99	SELF TAPPING SCREW	5
9E	9SG6571-2	115V SUPPLY PC BD ASBLY	1
	9ST9187-13	#10-24HLN-1817/1-NYLON INSERT	2
9G	9SS10404-137	RESISTOR-WW100W2005%	1
	9SCF000191	#10-24X7.50RHS	1
	9SE106A-1	LOCKWASHER	1
	9ST4479-A	INSULATING WASHER	2
	9ST9187-13	#10-24HLN-1817/1-NYLON INSERT	2
	9SL16053	REAR DIVIDER PANEL ASSEMBLY	1
10A	9SG5053	REAR DIVIDER PANEL	1
10B	9SG7245	CHOPPER - HEATSINK ASBLY	1
	9SS9262-27	PLAIN WASHER	1
	9ST9187-13	#10-24HLN-1817/1-NYLON INSERT	2
10E	9SM22489-2	INPUT PC BD ASBLY	1
	9SS9262-27	PLAIN WASHER	1
	9ST9187-13	#10-24HLN-1817/1-NYLON INSERT	2
	9ST9187-13	#10-24HLN-1817/1-NYLON INSERT	2
	9SS9225-99	SELF TAPPING SCREW	5

Base & Power Conversion Assembly

KEY	PART NUMBER	DESCRIPTION	QTY
11A	9SL15732-1	40 V DC BUS BD ASBLY	1
	9ST9187-13	#10-24HLN-1817/1-NYLON INSERT	2
14A	9SS10404-127	RESISTORWW100W1005%	1
	9ST4479-A	INSULATING WASHER	2
	9SS9262-27	PLAIN WASHER	1
	9ST9695-1	LOCKWASHER	1
	9SCF000191	#10-24X7.50RHS	1
18A	9SL16032	INPUT CORD COVER	1
	9ST9187-13	#10-24HLN-1817/1-NYLON INSERT	2
	9SS9225-99	SELF TAPPING SCREW	5
19A	9SM22847	FAN BAFFLE	1
	9ST9187-13	#10-24HLN-1817/1-NYLON INSERT	2
20	9ST13260-4	DECAL-EARTH GROUND CONN	1
	9SS28105	MYLAR INSULATION	1
21B	9SS20763-3	TERMINAL BLOCK	1
	9SCF000193	#8-32X1.25RHS	2
22	9SG8555	Nameplate	1
23A	9SS28841	GROUND LUG	1
	9SCF000013	1/4-20X.625HHCS	1
	9ST9695-17	LOCKWASHER	1
30A	9SG7150	POWER CONVERSION ASBLY	1
	9SS9225-99	SELF TAPPING SCREW	5
	9SS9262-27	PLAIN WASHER	1
	9ST9187-13	#10-24HLN-1817/1-NYLON INSERT	2
31A	9SM22895	AIR BAFFLE	1
	9ST9187-13	#10-24HLN-1817/1-NYLON INSERT	2
32	9SM22908	INPUT BOARD COVER	1
33	9SS18491-3	M.O.V. ASBLY	1

Base & Power Conversion Assembly

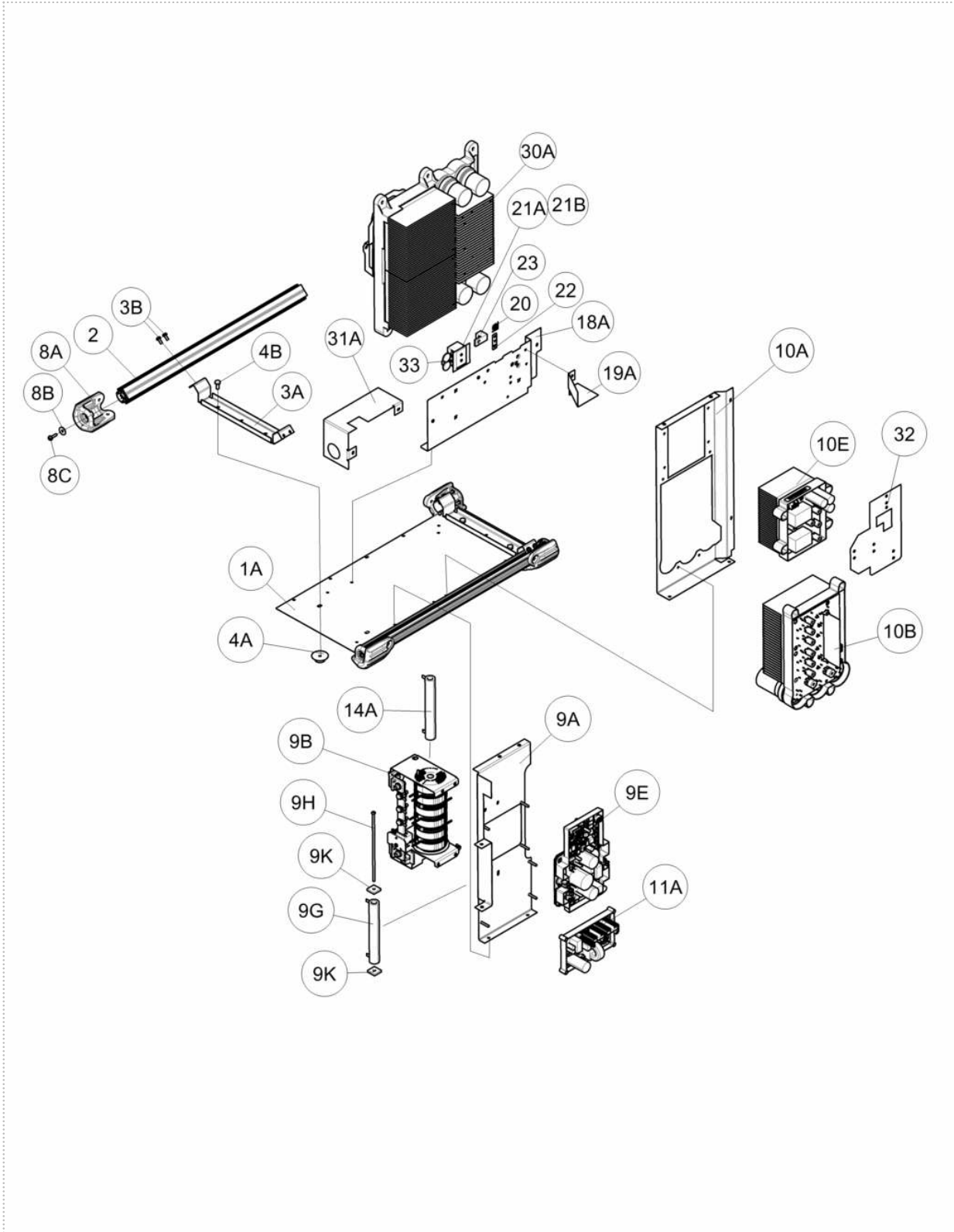

P-885-D.jpg

Case Back Assembly

KEY	PART NUMBER	DESCRIPTION	QTY
	9SG7163-5	Case Back Assembly	1
1A	9SG7186	FAN BRACKET	1
	9ST9187-13	#10-24HLN-1817/1-NYLON INSERT	2
2A	9SM22853	FAN ASBLY	3
2B	9SCF000058	#8-32X2.50RHS	12
	9SS9262-3	PLAIN WASHER	12
	9ST4291-A	LOCKWASHER	12
3	9SG5051-1	CASE BACK	1
4A	9SS19999	CORD GRIP CONNECTOR	1
4B	9ST14370-3	CONDUIT LOCKNUT	1
5A	9SM19969-9	ETHERNET RECEPTACLE BULKHEAD	1
5B	9SM19969-4	ETHERNET RECEPTACLE COVER	1
5C	9SS25438-9	ADAPTER PLATE	1
	9ST9187-13	#10-24HLN-1817/1-NYLON INSERT	2
	9SL15109-1	FAN HARNESS	1
8A	9ST12287-20	CIRCUIT BREAKER-10A250VAC	2
8B	9SS22061-3	SEALING BOOT	2
9A	9SS25438-3	COVER PLATE	1
	9ST9187-13	#10-24HLN-1817/1-NYLON INSERT	2
10A	9SS20184	RECEPTACLE-DUPLEX (20A-125V)	1
10B	9SM16996	RECEPTACLE COVER	1
10C	9SM22176	DECAL (115V RECEPTACLE)	2
	9SS9225-100	SELF TAPPING SCREW	2
	9ST9187-13	#10-24HLN-1817/1-NYLON INSERT	2
	9SM21927-1	PLUG AND LEAD ASBLY	1
11A	9SS12021-79	BOX RECEPTACLE SOLID SHELL	1
11B	9SS25438-2	CONNECTOR ADAPTER PLATE	1
	9SS8025-96	SELF TAPPING SCREW	2
	9ST9187-13	#10-24HLN-1817/1-NYLON INSERT	2
12	9SS17062-9	CABLE CONNECTOR CAP	1
13A	9SL15108-2	BRICKWORK PANEL	1
	9SS9225-99	SELF TAPPING SCREW	4
	9SM22519	CONNECTOR & LEAD ASBLY	1
	9SS12021-73	BOX RECEPTACLE SOLID SHELL	1

Case Back Assembly

KEY	PART NUMBER	DESCRIPTION	QTY
	9SS8025-118	SELF TAPPING SCREW	2
	9SS17062-10	CABLE CONNECTOR CAP	1
16	9SG8555	Nameplate	1
	9SL15110	RECEPTACLE HARNESS	1
	9SS26124	GROUND REFERENCE	1
	9SCF000010	#10-24HN	2
	9SE106A-1	LOCKWASHER	1
	9SS18858-17	SUPPRESSOR ASSEMBLY	1
	9SL13418-2	WIRING HARNESS	1
23A	9SS28068-2	ADAPTER PLATE	1
	9SS24843-12	HEADER PLUG	1
	9ST9187-13	#10-24HLN-1817/1-NYLON INSERT	2
24A	9SS28547	SOLENOID MTG PLATE	1
	9SS9225-99	SELF TAPPING SCREW	4
24C	9ST10397-4	PLUG BUTTON	1
	9SS9225-99	SELF TAPPING SCREW	4

Case Back Assembly

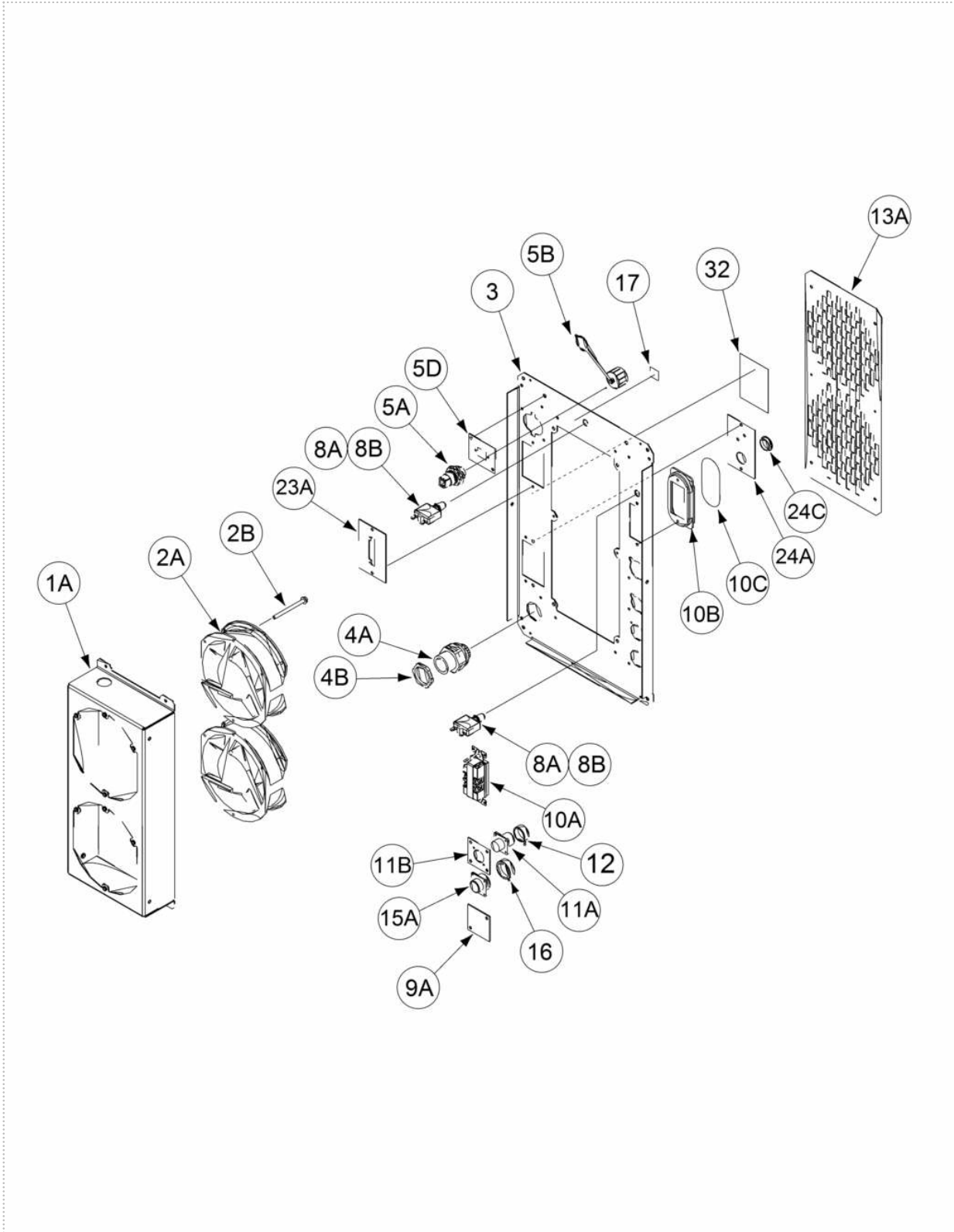

P-885-E.jpg

Roof Assembly

KEY	PART NUMBER	DESCRIPTION	QTY
	9SL15724-5	Roof Assembly	1
1A	9SL12763-6	ROOF	1
1B	9SG8555	Nameplate	1
1C	9SL8064-1	WARNING DECAL (INTERNATIONAL)	1
	9SS9225-99	SELF TAPPING SCREW	2
	9SM22375-2	CASE BACK ASSEMBLY	1
2A	9SG5054	TOP SHELF	1
2B	9SM21251-1	TOP EXTRUSION	2
	9SS9225-99	SELF TAPPING SCREW	2
	9ST9187-13	#10-24HLN-1817/1-NYLON INSERT	4
	9SS9225-99	SELF TAPPING SCREW	2
3A	9SL15070	HANDLE MOUNTING BRACKET	2
	9SS9225-100	SELF TAPPING SCREW	4
5A	9SL13138	CORNER CAP	4
	9SS9262-182	PLAIN WASHER	4
	9SS9225-100	SELF TAPPING SCREW	4
6A	9SL16139	INPUT CHOKE ASBLY	1
	9SS9225-99	SELF TAPPING SCREW	2
	9SCF000010	#10-24HN	1
	9SM22781	LEFT CASE SIDE	1
7A	9SL15257	LEFT CASE SIDE	1
8B	9SS27368-4	DECAL LE LOGO	1
8C	9SS27468	POWERWAVE LOGO	1
7D	9SM15045-110	ACOUSTICAL FOAM	2
7E	9SM22907	ACCESS DOOR	1
	9SS9225-99	SELF TAPPING SCREW	2
7G	9SS20900	WARNING DECAL	1
	9SM22782	RIGHT CASE SIDE	1
8A	9SL15258	RIGHT CASE SIDE	1
8B	9SS27368-4	DECAL LE LOGO	1
8C	9SS27468	POWERWAVE LOGO	1
8D	9SG7188-5	Wiring Diagram	1
8E	9SS28039-2	DECAL GREEN INITIATIVE	1
	9SS9262-182	PLAIN WASHER	4

Roof Assembly

KEY	PART NUMBER	DESCRIPTION	QTY
	9SS9225-100	SELF TAPPING SCREW	4
	9SS9225-99	SELF TAPPING SCREW	2
10A	9SS29514-4	CONTROL BOARD ASBLY	1
	9ST9187-13	#10-24HLN-1817/1-NYLON INSERT	4
12A	9SS28626-5	FEEDHEAD PC BD ASBLY	1
	9ST9187-13	#10-24HLN-1817/1-NYLON INSERT	4
13A	9SM24649	VOLTAGE SENSE BRACKET	1
13B	9SM19540-3	VOLTAGE SENSE SELECT PC BD ASBLY	1
13C	9ST13637-6	DIODE-BRIDGE35A400VF-W1-PH	1
	9SS9262-27	PLAIN WASHER	1
	9SE106A-1	LOCKWASHER	1
	9SCF000010	#10-24HN	1
	9SS9225-99	SELF TAPPING SCREW	2
14	9SM19969-13	ETHERNET PATCH CABLE ASBLY	1
16A	9SG6525-3	HANDLE	2
16B	9SCF000410	1/4-20x.75HHCS-FULL-GR2-4554	8
	9SE106A-27	LOCK WASHER	8

Roof Assembly

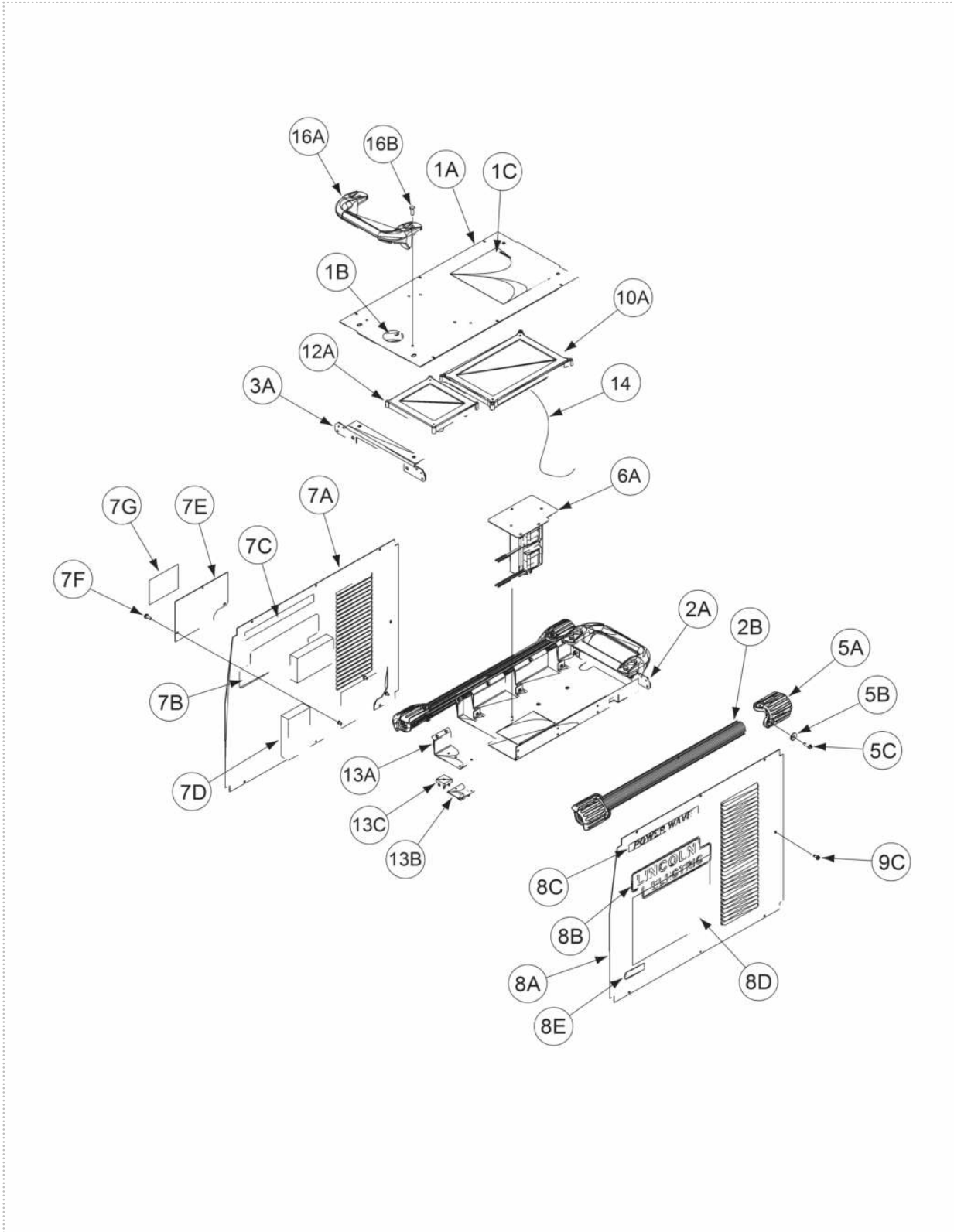

P-885-F.jpg

			
WARNING	<ul style="list-style-type: none"> ● Do not touch electrically live parts or electrode with skin or wet clothing. ● Insulate yourself from work and ground. 	<ul style="list-style-type: none"> ● Keep flammable materials away. 	<ul style="list-style-type: none"> ● Wear eye, ear and body protection.
Spanish AVISO DE PRECAUCION	<ul style="list-style-type: none"> ● No toque las partes o los electrodos bajo carga con la piel o ropa mojada. ● Aíslese del trabajo y de la tierra. 	<ul style="list-style-type: none"> ● Mantenga el material combustible fuera del área de trabajo. 	<ul style="list-style-type: none"> ● Protéjase los ojos, los oídos y el cuerpo.
French ATTENTION	<ul style="list-style-type: none"> ● Ne laissez ni la peau ni des vêtements mouillés entrer en contact avec des pièces sous tension. ● Isolez-vous du travail et de la terre. 	<ul style="list-style-type: none"> ● Gardez à l'écart de tout matériel inflammable. 	<ul style="list-style-type: none"> ● Protégez vos yeux, vos oreilles et votre corps.
German WARNUNG	<ul style="list-style-type: none"> ● Berühren Sie keine stromführenden Teile oder Elektroden mit Ihrem Körper oder feuchter Kleidung! ● Isolieren Sie sich von den Elektroden und dem Erdboden! 	<ul style="list-style-type: none"> ● Entfernen Sie brennbares Material! 	<ul style="list-style-type: none"> ● Tragen Sie Augen-, Ohren- und Körperschutz!
Portuguese ATENÇÃO	<ul style="list-style-type: none"> ● Não toque partes elétricas e electrodos com a pele ou roupa molhada. ● Isole-se da peça e terra. 	<ul style="list-style-type: none"> ● Mantenha inflamáveis bem guardados. 	<ul style="list-style-type: none"> ● Use proteção para a vista, ouvido e corpo.
Japanese 注意事項	<ul style="list-style-type: none"> ● 通電中の電気部品、又は溶材にヒフやぬれた布で触れないこと。 ● 施工物やアースから身体が絶縁されている様にして下さい。 	<ul style="list-style-type: none"> ● 燃えやすいものの側での溶接作業は絶対にしてはなりません。 	<ul style="list-style-type: none"> ● 目、耳及び身体に保護具をして下さい。
Chinese 警告	<ul style="list-style-type: none"> ● 皮肤或湿衣物切勿接触带电部件及焊条。 ● 使你自已与地面和工件绝缘。 	<ul style="list-style-type: none"> ● 把一切易燃物品移离工作场所。 	<ul style="list-style-type: none"> ● 佩戴眼、耳及身体劳动保护用具。
Korean 위험	<ul style="list-style-type: none"> ● 전도체나 용접봉을 젖은 형갑 또는 피부로 절대 접촉치 마십시오. ● 모재와 접지를 접촉치 마십시오. 	<ul style="list-style-type: none"> ● 인화성 물질을 접근시키지 마십시오. 	<ul style="list-style-type: none"> ● 눈, 귀와 몸에 보호장구를 착용하십시오.
Arabic تحذير	<ul style="list-style-type: none"> ● لا تلمس الاجزاء التي يسري فيها التيار الكهربائي أو الألكترود بجسد الجسم أو بالملابس المبللة بالماء. ● ضع عازلا على جسمك خلال العمل. 	<ul style="list-style-type: none"> ● ضع المواد القابلة للاشتعال في مكان بعيد. 	<ul style="list-style-type: none"> ● ضع أدوات وملابس واقية على عينيك وأذنيك وجسمك.

READ AND UNDERSTAND THE MANUFACTURER'S INSTRUCTION FOR THIS EQUIPMENT AND THE CONSUMABLES TO BE USED AND FOLLOW YOUR EMPLOYER'S SAFETY PRACTICES.

SE RECOMIENDA LEER Y ENTENDER LAS INSTRUCCIONES DEL FABRICANTE PARA EL USO DE ESTE EQUIPO Y LOS CONSUMIBLES QUE VA A UTILIZAR, SIGA LAS MEDIDAS DE SEGURIDAD DE SU SUPERVISOR.

LISEZ ET COMPRENEZ LES INSTRUCTIONS DU FABRICANT EN CE QUI REGARDE CET EQUIPMENT ET LES PRODUITS A ETRE EMPLOYES ET SUIVEZ LES PROCEDURES DE SECURITE DE VOTRE EMPLOYEUR.

LESEN SIE UND BEFOLGEN SIE DIE BETRIEBSANLEITUNG DER ANLAGE UND DEN ELEKTRODENEINSATZ DES HERSTELLERS. DIE UNFALLVERHÜTUNGSVORSCHRIFTEN DES ARBEITGEBERS SIND EBENFALLS ZU BEACHTEN.

			
<ul style="list-style-type: none"> ● Keep your head out of fumes. ● Use ventilation or exhaust to remove fumes from breathing zone. 	<ul style="list-style-type: none"> ● Turn power off before servicing. 	<ul style="list-style-type: none"> ● Do not operate with panel open or guards off. 	WARNING
<ul style="list-style-type: none"> ● Los humos fuera de la zona de respiración. ● Mantenga la cabeza fuera de los humos. Utilice ventilación o aspiración para gases. 	<ul style="list-style-type: none"> ● Desconectar el cable de alimentación de poder de la máquina antes de iniciar cualquier servicio. 	<ul style="list-style-type: none"> ● No operar con panel abierto o guardas quitadas. 	Spanish AVISO DE PRECAUCION
<ul style="list-style-type: none"> ● Gardez la tête à l'écart des fumées. ● Utilisez un ventilateur ou un aspirateur pour ôter les fumées des zones de travail. 	<ul style="list-style-type: none"> ● Débranchez le courant avant l'entretien. 	<ul style="list-style-type: none"> ● N'opérez pas avec les panneaux ouverts ou avec les dispositifs de protection enlevés. 	French ATTENTION
<ul style="list-style-type: none"> ● Vermeiden Sie das Einatmen von Schweißrauch! ● Sorgen Sie für gute Be- und Entlüftung des Arbeitsplatzes! 	<ul style="list-style-type: none"> ● Strom vor Wartungsarbeiten abschalten! (Netzstrom völlig öffnen; Maschine anhalten!) 	<ul style="list-style-type: none"> ● Anlage nie ohne Schutzgehäuse oder Innenschutzverkleidung in Betrieb setzen! 	German WARNUNG
<ul style="list-style-type: none"> ● Mantenha seu rosto da fumaça. ● Use ventilação e exaustão para remover fumo da zona respiratória. 	<ul style="list-style-type: none"> ● Não opere com as tampas removidas. ● Desligue a corrente antes de fazer serviço. ● Não toque as partes elétricas nuas. 	<ul style="list-style-type: none"> ● Mantenha-se afastado das partes moventes. ● Não opere com os painéis abertos ou guardas removidas. 	Portuguese ATENÇÃO
<ul style="list-style-type: none"> ● ヒュームから頭を離すようにして下さい。 ● 換気や排煙に十分留意して下さい。 	<ul style="list-style-type: none"> ● メンテナンス・サービスに取りかかる際には、まず電源スイッチを必ず切して下さい。 	<ul style="list-style-type: none"> ● パネルやカバーを取り外したままで機械操作をしないで下さい。 	Japanese 注意事項
<ul style="list-style-type: none"> ● 頭部遠離煙霧。 ● 在呼吸區使用通風或排風器除煙。 	<ul style="list-style-type: none"> ● 維修前切斷電源。 	<ul style="list-style-type: none"> ● 儀表板打開或沒有安全罩時不準作業。 	Chinese 警告
<ul style="list-style-type: none"> ● 얼굴로부터 용접가스를 멀리하십시오. ● 호흡지역으로부터 용접가스를 제거하기 위해 가스제거기나 통풍기를 사용하십시오. 	<ul style="list-style-type: none"> ● 보수전에 전원을 차단하십시오. 	<ul style="list-style-type: none"> ● 판넬이 열린 상태로 작동치 마십시오. 	Korean 위험
<ul style="list-style-type: none"> ● ابعء رأسك بعيداً عن الدخان. ● استعمل التهوية أو جهاز ضغط الدخان للخارج لكي تبعء الدخان عن المنطقة التي تتنفس فيها. 	<ul style="list-style-type: none"> ● اقطع التيار الكهربائي قبل القيام بأية صيانة. 	<ul style="list-style-type: none"> ● لا تشغيل هذا الجهاز اذا كانت الاغطية الحديدية الواقية ليست عليه. 	Arabic تحذير

LEIA E COMPREENDA AS INSTRUÇÕES DO FABRICANTE PARA ESTE EQUIPAMENTO E AS PARTES DE USO, E SIGA AS PRÁTICAS DE SEGURANÇA DO EMPREGADOR.

使う機械や溶材のメーカーの指示書をよく読み、まず理解して下さい。そして貴社の安全規定に従って下さい。

請詳細閱讀並理解製造廠提供的說明以及應該使用的銀焊材料，並請遵守貴方的有閣勞動保護規定。

이 제품에 동봉된 작업지침서를 숙지하시고 귀사의 작업자 안전수칙을 준수하시기 바랍니다.

اقرأ بتمعن وافهم تعليمات المصنع المنتج لهذه المعدات والمواد قبل استعمالها واتبع تعليمات الوقاية لصاحب العمل.

CUSTOMER ASSISTANCE POLICY

The business of The Lincoln Electric Company is manufacturing and selling high quality welding equipment, consumables, and cutting equipment. Our challenge is to meet the needs of our customers and to exceed their expectations. On occasion, purchasers may ask Lincoln Electric for advice or information about their use of our products. We respond to our customers based on the best information in our possession at that time. Lincoln Electric is not in a position to warrant or guarantee such advice, and assumes no liability, with respect to such information or advice. We expressly disclaim any warranty of any kind, including any warranty of fitness for any customer's particular purpose, with respect to such information or advice. As a matter of practical consideration, we also cannot assume any responsibility for updating or correcting any such information or advice once it has been given, nor does the provision of information or advice create, expand or alter any warranty with respect to the sale of our products.

Lincoln Electric is a responsive manufacturer, but the selection and use of specific products sold by Lincoln Electric is solely within the control of, and remains the sole responsibility of the customer. Many variables beyond the control of Lincoln Electric affect the results obtained in applying these types of fabrication methods and service requirements.

Subject to Change – This information is accurate to the best of our knowledge at the time of printing. Please refer to www.lincolnelectric.com for any updated information.



THE LINCOLN ELECTRIC COMPANY

22801 St. Clair Avenue • Cleveland, OH • 44117-1199 • U.S.A.
Phone: +1.216.481.8100 • www.lincolnelectric.com