

MODEL 651

TWO-STAGE FLOWMETER REGULATOR WITH SHIELDING GAS SAVING FEATURE



Model shown:
651-30L-AR

KEY FEATURES

- Two-stage flowmeter regulator
- Forged brass body for maximum strength
- Cylinder gas supplied
- Inlet filter to protect against contamination
- Precise gas flow control
- Strong flowmeter resistant to mechanical damages
- Polycarbonate outer tube cover with good 360° visibility
- First stage - capsule valve with Kel-F (CTFE) seat
- Second stage - one-piece encapsulated seat design with internal filter and PTFE (Teflon®*) seat
- Lockable version available
- 7 year warranty

Applications »

All types of welding
Designed to deliver high accuracy gas flow
and to reduce the consumption of shielding gas



TECHNICAL DATA

Standard	ISO 2503
Gauges	40 mm
Maximum Inlet Pressure [bar]	300
Maximum Flow [LpM]	30

MATERIALS

Body	Brass
Bonnet	Zinc-Aluminium Alloy
Diaphragm (regulator)	Neoprene rubber
Nozzle	Brass
Seals	NBR / Viton
Filter	Electroless nickel plated bronze
Adjusting Knob	Aluminium 6026

TECHNICAL DRAWINGS

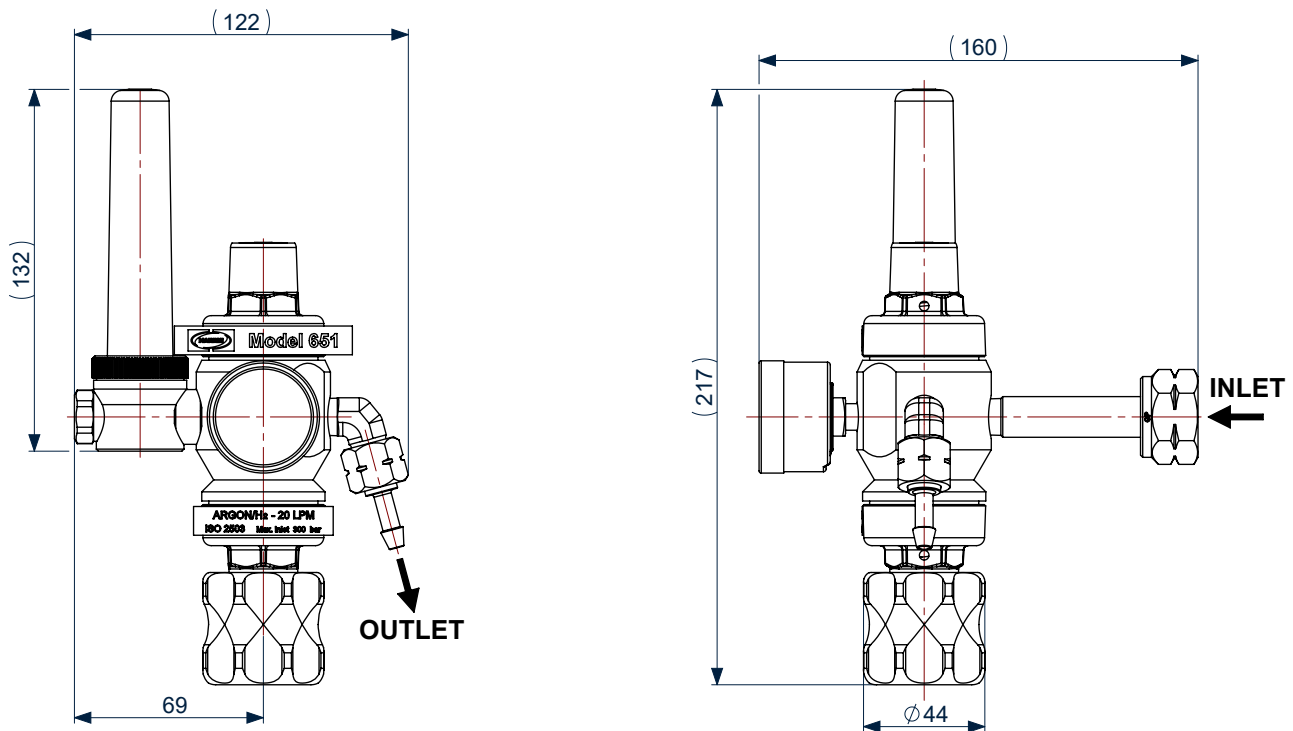

CUSTOMER ASSISTANCE POLICY

The business of Lincoln Electric is manufacturing and selling high quality welding equipment, automated welding systems, consumables, and cutting equipment. Our challenge is to meet the needs of our customers, who are experts in their fields, and to exceed their expectations. On occasion, purchasers may ask Lincoln Electric for information or technical information about their use of our products. Our employees respond to inquiries to the best of their ability based on information and specifications provided to them by the customers and the knowledge they may have concerning the application. Our employees, however, are not in a position to verify the information provided or to evaluate the engineering requirements for the particular weldment, or to provide engineering advice in relation to a specific situation. Accordingly, Lincoln Electric does not warrant or guarantee or assume any liability with respect to such information or communications. Moreover, the provision of such information or technical information does not create, expand, or alter any warranty on our products. Any express or implied warranty that might arise from the information or technical information, including any implied warranty of merchantability or any warranty of fitness for any customers' particular purpose or any other equivalent or similar warranty is specifically disclaimed.

Lincoln Electric is a responsive manufacturer, but the definition of specifications, and the selection and use of specific products sold by Lincoln Electric is solely within the control of, and remains the sole responsibility of the customer. Many variables beyond the control of Lincoln Electric affect the results obtained in applying these types of fabrication methods and service requirements.



Contact Harris for pricing and custom configurations

+48 74 646 23 52

marketingharris@lincolnelectric.eu

Harris Products Group
ul. Strefowa 8, 58-200 Dzierzoniow, Poland
www.harrisproductsgroup.eu