

# FLEXTEC 450 WIRING DIAGRAM G6890-2 REV: A

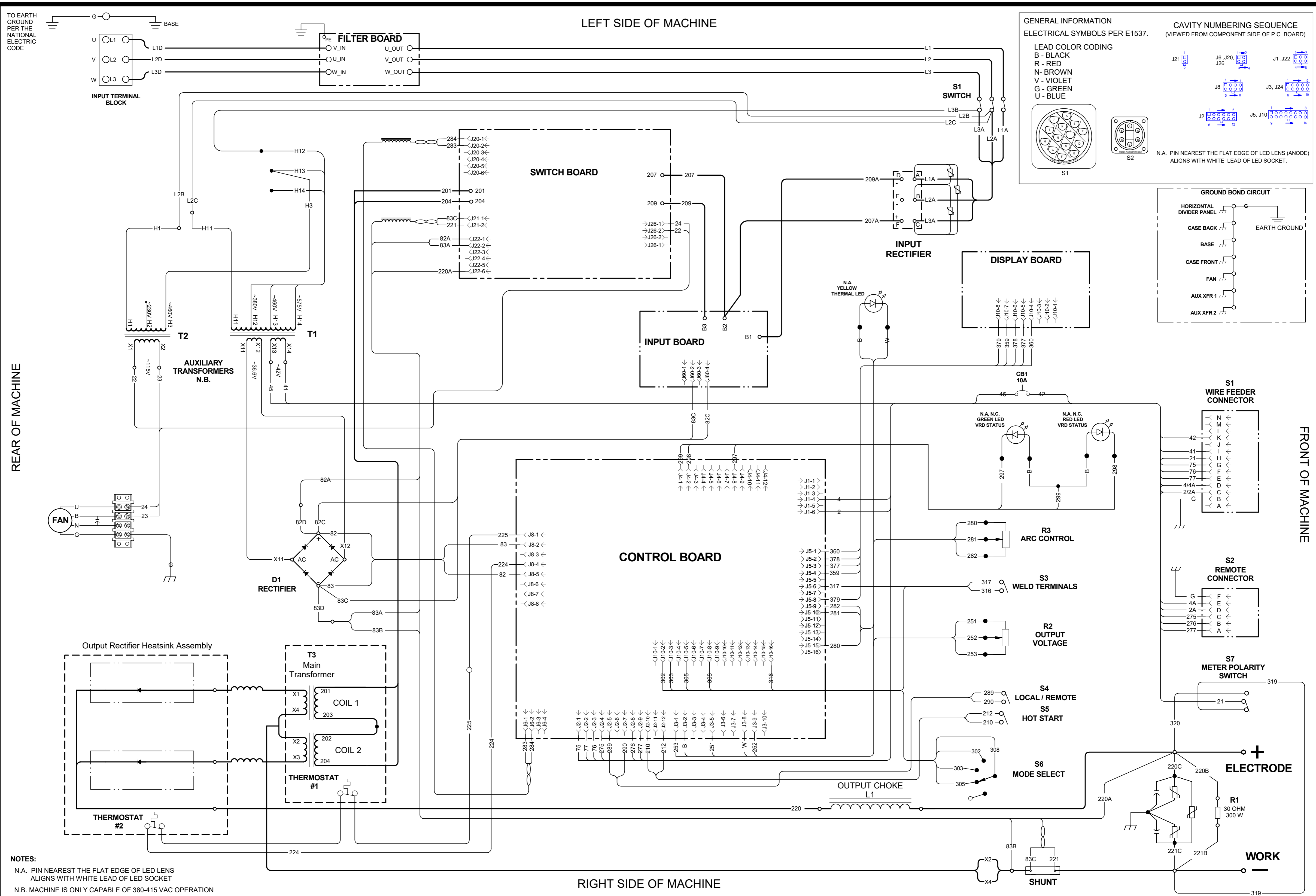

**GENERAL INFORMATION**  
ELECTRICAL SYMBOLS PER E1537.

**LEAD COLOR CODING**  
B - BLACK  
R - RED  
N - BROWN  
V - VIOLET  
G - GREEN  
U - BLUE

**CAVITY NUMBERING SEQUENCE**  
(VIEWED FROM COMPONENT SIDE OF P.C. BOARD)

N.A. PIN NEAREST THE FLAT EDGE OF LED LENS (ANODE) ALIGNS WITH WHITE LEAD OF LED SOCKET.

REAR OF MACHINE

FRONT OF MACHINE

**NOTES:**  
N.A. PIN NEAREST THE FLAT EDGE OF LED LENS ALIGNS WITH WHITE LEAD OF LED SOCKET  
N.B. MACHINE IS ONLY CAPABLE OF 380-415 VAC OPERATION  
N.C. LED'S ARE ONLY ACTIVE IF VRD IS TURNED ON. TURN ON VRD BY PLACING DIP SWITCH 5 ON CONTROL BOARD IN THE "ON" POSITION

LEFT SIDE OF MACHINE

RIGHT SIDE OF MACHINE

