

MODEL 818

SINGLE-STAGE GAUGELESS REGULATOR



Model shown:
818-4-LP

KEY FEATURES

- Maximum inlet pressure of 230 bar
- Enough flow to cut up 300 mm steel
- Smooth adjustment with high precision
- Forged brass body for maximum strength
- One-piece encapsulated seat design with internal filter and PTFE (Teflon®*) seat
- Side inlet connection
- Cylinder pressure shown on indicator with polycarbonate cover
- Delivery pressure set by turning the knob on calibrated bonnet
- "B" version fitted with black bonnet
- 7 year warranty

Applications »

- Medium duty cutting, heating and welding.
- All industrial applications in the toughest working conditions.



TECHNICAL DATA

Standard	ISO 2503
Gauges	None
Maximum Inlet Pressure [bar]	230
Maximum Delivery Pressure [bar]	10

MATERIALS

Body	Brass
Bonnet	Zinc-Aluminium Alloy
Diaphragm (regulator)	Neoprene rubber
Nozzle	Brass
Seals	NBR / Viton
Filter	Electroless nickel plated bronze
Adjusting Knob	ABS Plastic

TECHNICAL DRAWINGS

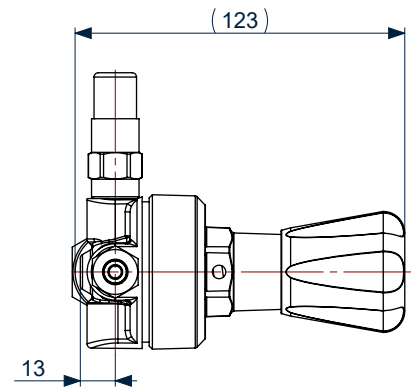
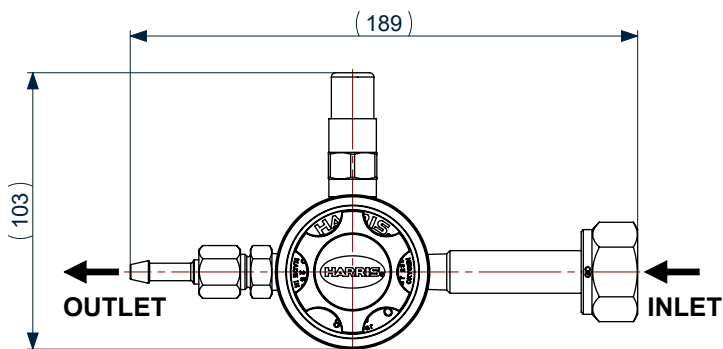

FLOW CHARTS

REGULATOR FLOW CURVE
818 1.5 bar AC

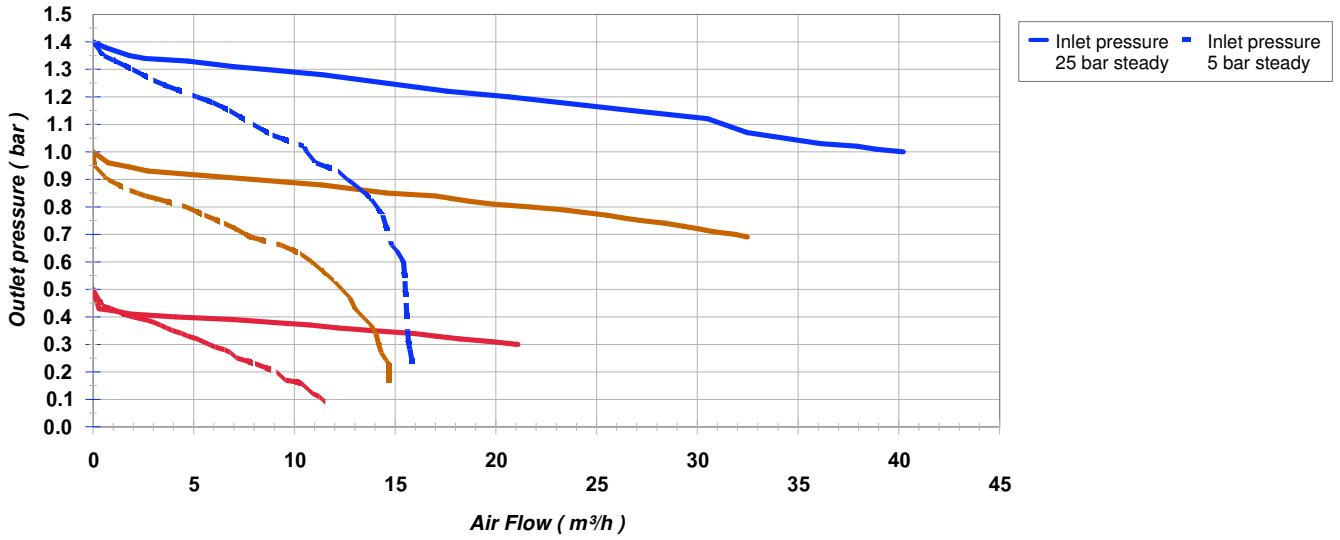

REGULATOR FLOW CURVE
818 4 bar LPG

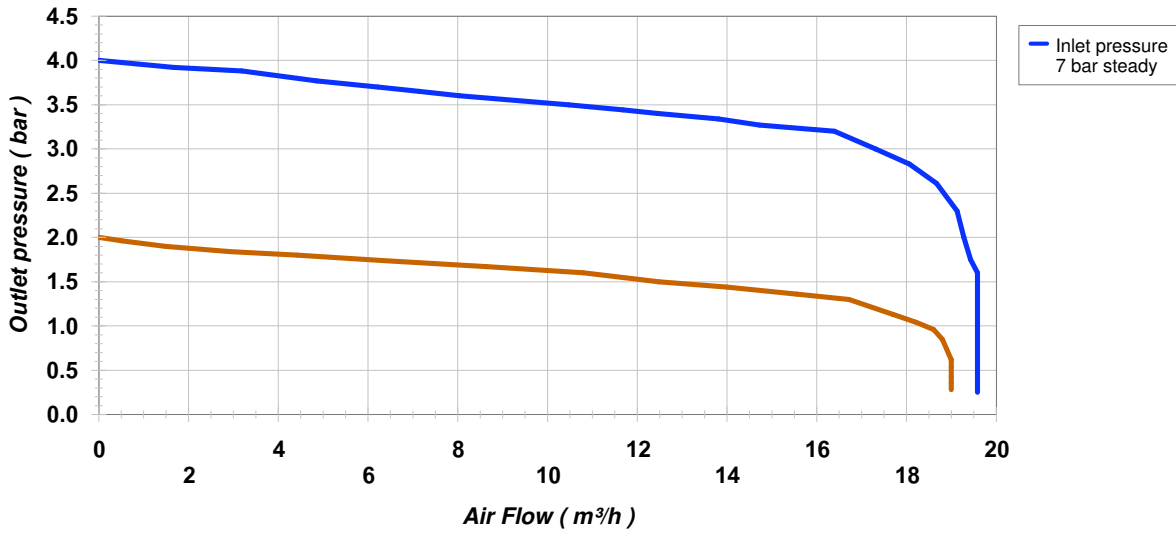

REGULATOR FLOW CURVE
818 10 bar

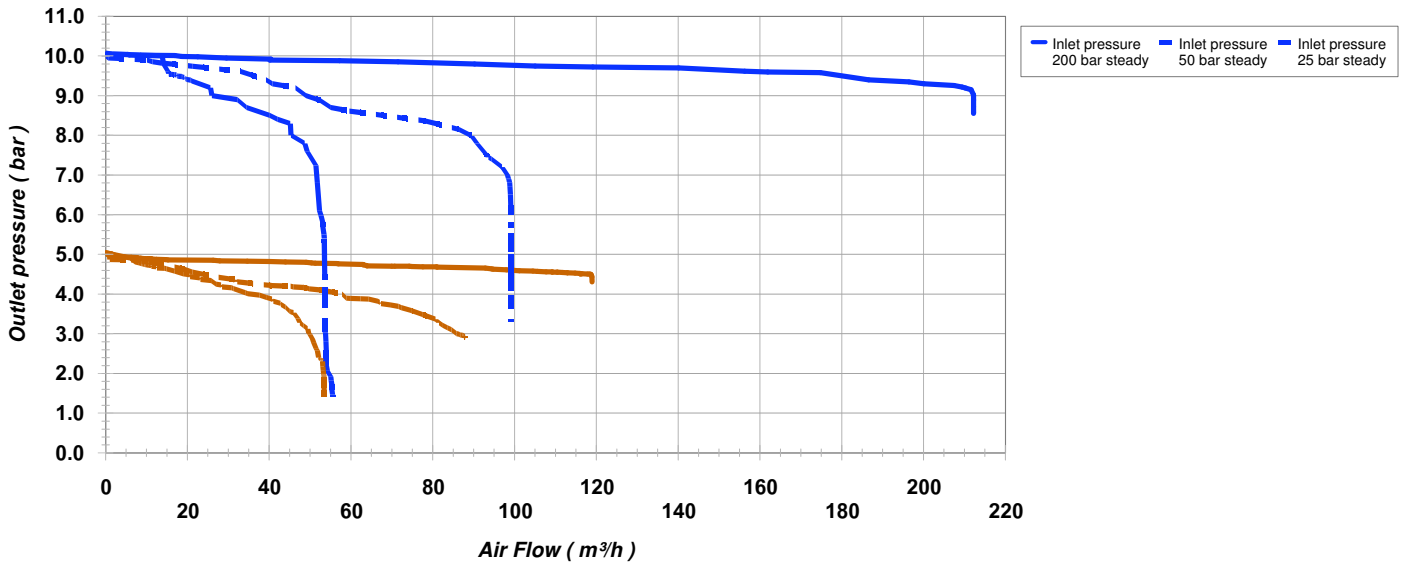

PRODUCT CONFIGURATION

REG, 818

TYPE CODE (Only if non-standard)	
-	Horizontal entry (standard)
V	Placed in Kit
E	Vertical entry
A	Anti vibrator (lightweight gases)
D	IRV Diaphragm safety relief valve
R	External safety relief valve
S	Stainless steel diaphragm
B	Black-painted gauges
P	Without HP gauge
N	1/4" NPT gauge (std is 1/4" G)
G	Inlet connection 3/8"
W	Outlet valve (when not standard)
T	With lock "T" screw
X	With inlet stem valve "SNAP SAFE"

DELIVERY PRESSURE	
1,5	1,5 bar
4	4 bar
10	10 bar

CALIBRATION	
-	Pressure gauges calibrated bar or kPa
L	Flow gauge or indicator calibrated (lpm)
F	Flowmeter (lpm)
LK	Flow gauge or indicator in (lpm), Pressure gauge in kPa
FK	Flowmeter in (lpm), Pressure gauge in kPa

GAS	
OX	Oxygen
AC	Acetylene
AIR	Air
AR	Argon
CD	Carbon Dioxide
N	Nitrogen
H	Hydrogen
LP	Propane
HE	Helium

PROGRESSIVE NUMBER PERSONALIZES	
xxx	

When placing an order, use the code generated according to the table.

REG,818 | D | 10 | - | N | 1208

NOTES

CUSTOMER ASSISTANCE POLICY

The business of Lincoln Electric is manufacturing and selling high quality welding equipment, automated welding systems, consumables, and cutting equipment. Our challenge is to meet the needs of our customers, who are experts in their fields, and to exceed their expectations. On occasion, purchasers may ask Lincoln Electric for information or technical information about their use of our products. Our employees respond to inquiries to the best of their ability based on information and specifications provided to them by the customers and the knowledge they may have concerning the application. Our employees, however, are not in a position to verify the information provided or to evaluate the engineering requirements for the particular weldment, or to provide engineering advice in relation to a specific situation. Accordingly, Lincoln Electric does not warrant or guarantee or assume any liability with respect to such information or communications. Moreover, the provision of such information or technical information does not create, expand, or alter any warranty on our products. Any express or implied warranty that might arise from the information or technical information, including any implied warranty of merchantability or any warranty of fitness for any customers' particular purpose or any other equivalent or similar warranty is specifically disclaimed.

Lincoln Electric is a responsive manufacturer, but the definition of specifications, and the selection and use of specific products sold by Lincoln Electric is solely within the control of, and remains the sole responsibility of the customer. Many variables beyond the control of Lincoln Electric affect the results obtained in applying these types of fabrication methods and service requirements.



Contact Harris for pricing and custom configurations
 +48 74 646 23 52
 marketingharris@lincolnelectric.eu

Harris Products Group
 ul. Strefowa 8, 58-200 Dzierzoniow, Poland
 www.harrisproductsgroup.eu