



PREMIUM LASER ASSIST GAS START-UP KIT INSTALLATION INSTRUCTIONS

NOTE: All "item" numbers in the following instructions refer to corresponding item numbers on the Assist Gas installation instructions drawing. Familiarize yourself with the installation drawing and read all instructions before beginning installation.

STEP 1: Check Contents

1. Remove contents of system from packaging.
2. Inspect components visually to insure there is no damage. Do not install damaged components.

STEP 2: In a well ventilated area, determine mounting locations for all components. All components must be securely mounted to a substantial wall or surface using suitable mounting hardware (not included). Make sure there is adequate clearance on all sides of each component for proper operation.

STEP 3: Install pipe nipple (Item 8) and elbow (Item 5) in regulator outlet. Threads are ½" NPT and should be wrapped with Teflon tape. Tighten with wrench.

STEP 4: Install T-filter (Item 4) in elbow, pay attention to flow direction arrow on filter. Make sure there is adequate clearance to inspect and/or replace filter element. Threads are ½" NPT and should be wrapped with Teflon tape. Tighten with wrench.

STEP 5: Install tube fitting (Item 9) on outlet of T-filter and tube fitting on inlet of laser equipment. Use either Item 6 or 7 on laser inlet depending on thread size of laser inlet. Threads should be wrapped with Teflon tape. Tighten with wrench.

STEP 6: Attach hose (Item 7) to tube fittings installed in steps 4 and 5. Threads on flared ends of tube fittings are ¾"-16 and should not be taped. Hold tube fittings securely with one wrench and tighten flared swivel connection on hose ends with another wrench.

STEP 7: Detailed instructions for installation and operation of regulators is included with regulators. Follow regulator instructions for attaching regulator to cylinder.

STEP 8: Pressurize, leak test and purge system according to regulator and Laser manufacturers' instructions.

*** DO NOT use the system if any leaks are detected.

General Precautions

- Installation should be performed by personnel knowledgeable in the handling of compressed gases.
- Choose a location well ventilated for installation
- Use proper precautions when dealing with any compressed gas.
- The user should be familiar with the chemical and reactive properties of the gas being used (Read the MSDS of the gas being used).

Reference Material

The following safety bulletins are available on the Compressed Gas Association's website (www.cganet.com) or at (703) 412-0900:

- SB-2 Oxygen Deficient Atmospheres
- SB-10 Correct Labeling & Proper Fittings On Cylinders/Containers
- SB-15 Avoiding Hazards In Confined Work Spaces During Maintenance, Construction And Similar Activities
- SB-19 Potential Valve Thread & Cylinder Thread Mismatch

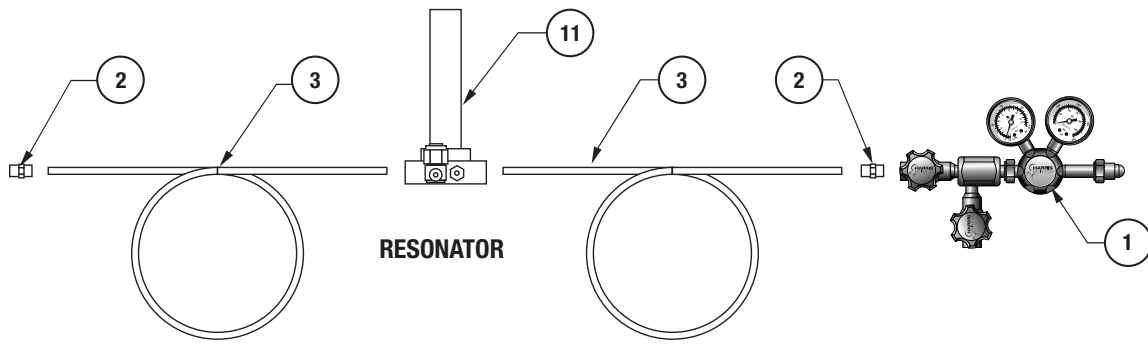

KIT # Y80-4703502

- | NO. | DESCRIPTION |
|------------------------|---|
| MAZAK COMBO KIT | |
| 1 | REG, HP722C-125-580 W/BLOCK AND BLEED |
| 2 | TUBE FITTING, 8MMX1/2NPT NIC |
| 3 | TUBING, 8MM X 100' 190PSI CLEAR |
| 4 | REG, 750-250-540 AIRGAS |
| 5 | REG, 750-500-580 AIRGAS |
| 6 | FILTER-T, 1/2" X 50' BLACK |
| 7 | HOSE, 1/2" X 50' BLACK 3/4-16 |
| 8 | ELBOW, 1/2" TO 3/8" CAST RED BR |
| 9 | FLARE - FITTING, 3/4" FLARE X 1/2" BSPP |
| 10 | FLARE - FITTING, 3/4" FLARE X 1/2" NPTM STL |
| 11 | FILTER, SIP PREMIX |
| 12 | ELBOW, 1/2NPT PIPE |
| 13 | NIPPLE, 2X1/2NPT PIPE |
| 14 | FLARE - FITTING, 3/4" FLARE X 1/2" NPTF STL |

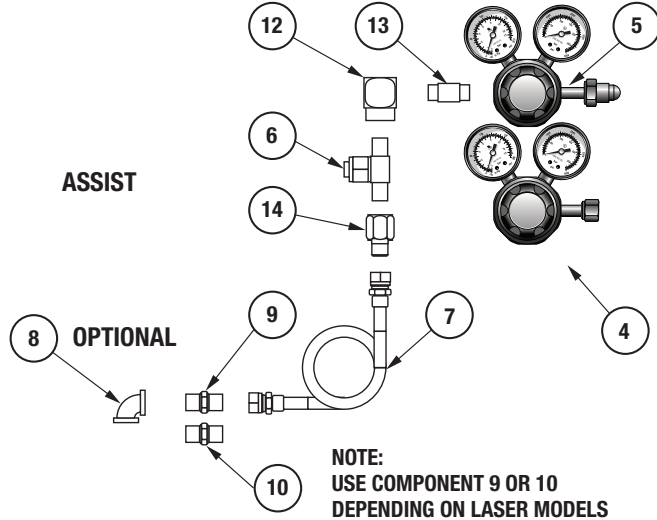

KIT # Y80-4703503

- | NO. | DESCRIPTION |
|----------------------------------|---|
| KIT, UNIVERSAL ASSIST GAS | |
| 1 | REG, 750-500-580 AIRGAS |
| 2 | REG, 750-250-540 AIRGAS |
| 3 | HOSE, 1/2" X 50' BLACK 3/4 - 16 |
| 4 | FILTER-T, 1/2" NPTM 90 MICRON |
| 5 | ELBOW, 1/2" NPT PIPE |
| 6 | FLARE - FITTING, 3/4" FLARE X 1/2" BSPP |
| 7 | FLARE - FITTING, 3/4" FLARE X 1/2" NPTM STL |
| 8 | NIPPLE, 2 X 1/2 NPT PIPE |
| 9 | FLARE - FITTING, 3/4" FLARE X 1/2" NPTF STL |

KIT # Y80-4703507

- | NO. | DESCRIPTION |
|-------------------------------------|---|
| KIT, UNIVERSAL ASSIST OXYGEN | |
| 10 | REG, 750-250-540 AIRGAS |
| 3 | HOSE, 1/2" X 50' BLACK 3/4 - 16 |
| 4 | FILTER-T, 1/2" NPTM 90 MICRON |
| 5 | ELBOW, 1/2" NPT PIPE |
| 6 | FLARE - FITTING, 3/4" FLARE X 1/2" BSPP |
| 7 | FLARE - FITTING, 3/4" FLARE X 1/2" NPTM STL |
| 8 | NIPPLE, 2 X 1/2 NPT PIPE |
| 9 | FLARE - FITTING, 3/4" FLARE X 1/2" NPTF STL |

KIT # Y80-4703506

- | NO. | DESCRIPTION |
|---------------------------------------|---|
| KIT, UNIVERSAL ASSIST NITROGEN | |
| 1 | REG, 750-500-580 AIRGAS |
| 3 | HOSE, 1/2" X 50' BLACK 3/4 - 16 |
| 4 | FILTER-T, 1/2" NPTM 90 MICRON |
| 5 | ELBOW, 1/2" NPT PIPE |
| 6 | FLARE - FITTING, 3/4" FLARE X 1/2" BSPP |
| 7 | FLARE - FITTING, 3/4" FLARE X 1/2" NPTM STL |
| 8 | NIPPLE, 2 X 1/2 NPT PIPE |
| 9 | FLARE - FITTING, 3/4" FLARE X 1/2" NPTF STL |

