

SP-135T

For use with machine Code Number:10971



This manual covers equipment which is no longer in production by The Lincoln Electric Co. Specifications and availability of optional features may have changed.

Safety Depends on You

Lincoln arc welding and cutting equipment is designed and built with safety in mind. However, your overall safety can be increased by proper installation ... and thoughtful operation on your part. **DO NOT INSTALL, OPERATE OR REPAIR THIS EQUIPMENT WITHOUT READING THIS MANUAL AND THE SAFETY PRECAUTIONS CONTAINED THROUGHOUT.** And, most importantly, think before you act and be careful.

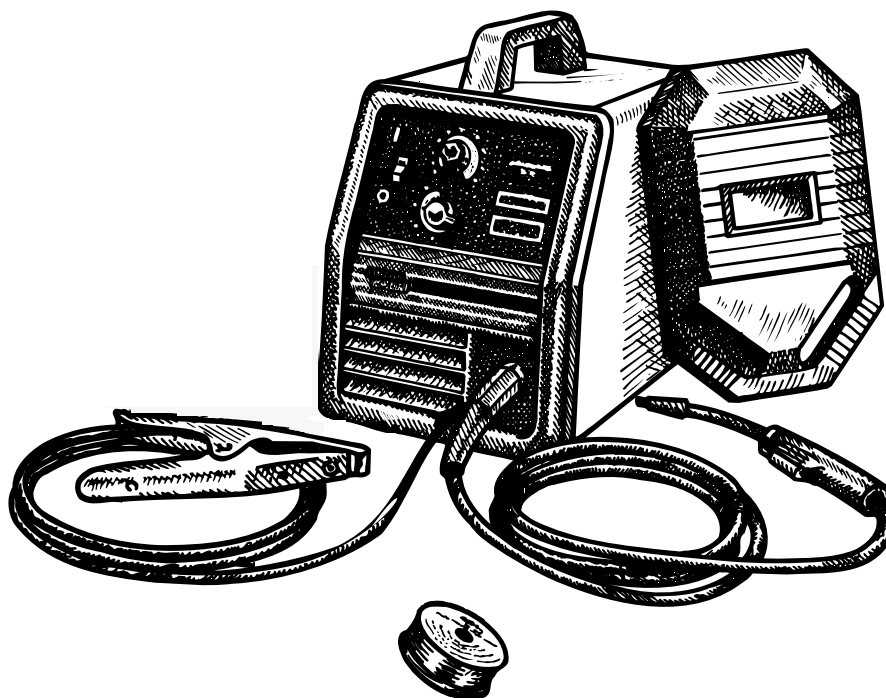

OPERATOR'S MANUAL

**LINCOLN[®]
ELECTRIC**

Copyright © 2004 Lincoln Global Inc.

- World's Leader in Welding and Cutting Products •
- Sales and Service through Subsidiaries and Distributors Worldwide •

Cleveland, Ohio 44117-1199 U.S.A. TEL: 216.481.8100 FAX: 216.486.1751 WEB SITE: www.lincolnelectric.com

⚠ WARNING

⚠ CALIFORNIA PROPOSITION 65 WARNINGS ⚠

Diesel engine exhaust and some of its constituents are known to the State of California to cause cancer, birth defects, and other reproductive harm.

The Above For Diesel Engines

The engine exhaust from this product contains chemicals known to the State of California to cause cancer, birth defects, or other reproductive harm.

The Above For Gasoline Engines

ARC WELDING CAN BE HAZARDOUS. PROTECT YOURSELF AND OTHERS FROM POSSIBLE SERIOUS INJURY OR DEATH. KEEP CHILDREN AWAY. PACEMAKER WEARERS SHOULD CONSULT WITH THEIR DOCTOR BEFORE OPERATING.

Read and understand the following safety highlights. For additional safety information, it is strongly recommended that you purchase a copy of "Safety in Welding & Cutting - ANSI Standard Z49.1" from the American Welding Society, P.O. Box 351040, Miami, Florida 33135 or CSA Standard W117.2-1974. A Free copy of "Arc Welding Safety" booklet E205 is available from the Lincoln Electric Company, 22801 St. Clair Avenue, Cleveland, Ohio 44117-1199.

BE SURE THAT ALL INSTALLATION, OPERATION, MAINTENANCE AND REPAIR PROCEDURES ARE PERFORMED ONLY BY QUALIFIED INDIVIDUALS.



FOR ENGINE powered equipment.

1.a. Turn the engine off before troubleshooting and maintenance work unless the maintenance work requires it to be running.



1.b. Operate engines in open, well-ventilated areas or vent the engine exhaust fumes outdoors.



1.c. Do not add the fuel near an open flame welding arc or when the engine is running. Stop the engine and allow it to cool before refueling to prevent spilled fuel from vaporizing on contact with hot engine parts and igniting. Do not spill fuel when filling tank. If fuel is spilled, wipe it up and do not start engine until fumes have been eliminated.

1.d. Keep all equipment safety guards, covers and devices in position and in good repair. Keep hands, hair, clothing and tools away from V-belts, gears, fans and all other moving parts when starting, operating or repairing equipment.

1.e. In some cases it may be necessary to remove safety guards to perform required maintenance. Remove guards only when necessary and replace them when the maintenance requiring their removal is complete. Always use the greatest care when working near moving parts.



1.f. Do not put your hands near the engine fan. Do not attempt to override the governor or idler by pushing on the throttle control rods while the engine is running.

1.g. To prevent accidentally starting gasoline engines while turning the engine or welding generator during maintenance work, disconnect the spark plug wires, distributor cap or magneto wire as appropriate.



1.h. To avoid scalding, do not remove the radiator pressure cap when the engine is hot.



ELECTRIC AND MAGNETIC FIELDS may be dangerous

2.a. Electric current flowing through any conductor causes localized Electric and Magnetic Fields (EMF). Welding current creates EMF fields around welding cables and welding machines

2.b. EMF fields may interfere with some pacemakers, and welders having a pacemaker should consult their physician before welding.

2.c. Exposure to EMF fields in welding may have other health effects which are now not known.

2.d. All welders should use the following procedures in order to minimize exposure to EMF fields from the welding circuit:

2.d.1. Route the electrode and work cables together - Secure them with tape when possible.

2.d.2. Never coil the electrode lead around your body.

2.d.3. Do not place your body between the electrode and work cables. If the electrode cable is on your right side, the work cable should also be on your right side.

2.d.4. Connect the work cable to the workpiece as close as possible to the area being welded.

2.d.5. Do not work next to welding power source.

Mar '95



ELECTRIC SHOCK can kill.

- 3.a. The electrode and work (or ground) circuits are electrically "hot" when the welder is on. Do not touch these "hot" parts with your bare skin or wet clothing. Wear dry, hole-free gloves to insulate hands.
- 3.b. Insulate yourself from work and ground using dry insulation. Make certain the insulation is large enough to cover your full area of physical contact with work and ground.
- In addition to the normal safety precautions, if welding must be performed under electrically hazardous conditions (in damp locations or while wearing wet clothing; on metal structures such as floors, gratings or scaffolds; when in cramped positions such as sitting, kneeling or lying, if there is a high risk of unavoidable or accidental contact with the workpiece or ground) use the following equipment:**
- Semiautomatic DC Constant Voltage (Wire) Welder.
 - DC Manual (Stick) Welder.
 - AC Welder with Reduced Voltage Control.
- 3.c. In semiautomatic or automatic wire welding, the electrode, electrode reel, welding head, nozzle or semiautomatic welding gun are also electrically "hot".
- 3.d. Always be sure the work cable makes a good electrical connection with the metal being welded. The connection should be as close as possible to the area being welded.
- 3.e. Ground the work or metal to be welded to a good electrical (earth) ground.
- 3.f. Maintain the electrode holder, work clamp, welding cable and welding machine in good, safe operating condition. Replace damaged insulation.
- 3.g. Never dip the electrode in water for cooling.
- 3.h. Never simultaneously touch electrically "hot" parts of electrode holders connected to two welders because voltage between the two can be the total of the open circuit voltage of both welders.
- 3.i. When working above floor level, use a safety belt to protect yourself from a fall should you get a shock.
- 3.j. Also see Items 6.c. and 8.



ARC RAYS can burn.

- 4.a. Use a shield with the proper filter and cover plates to protect your eyes from sparks and the rays of the arc when welding or observing open arc welding. Headshield and filter lens should conform to ANSI Z87.1 standards.
- 4.b. Use suitable clothing made from durable flame-resistant material to protect your skin and that of your helpers from the arc rays.
- 4.c. Protect other nearby personnel with suitable, non-flammable screening and/or warn them not to watch the arc nor expose themselves to the arc rays or to hot spatter or metal.



FUMES AND GASES can be dangerous.

- 5.a. Welding may produce fumes and gases hazardous to health. Avoid breathing these fumes and gases. When welding, keep your head out of the fume. Use enough ventilation and/or exhaust at the arc to keep fumes and gases away from the breathing zone. **When welding with electrodes which require special ventilation such as stainless or hard facing (see instructions on container or MSDS) or on lead or cadmium plated steel and other metals or coatings which produce highly toxic fumes, keep exposure as low as possible and below Threshold Limit Values (TLV) using local exhaust or mechanical ventilation. In confined spaces or in some circumstances, outdoors, a respirator may be required. Additional precautions are also required when welding on galvanized steel.**
- 5.b. Do not weld in locations near chlorinated hydrocarbon vapors coming from degreasing, cleaning or spraying operations. The heat and rays of the arc can react with solvent vapors to form phosgene, a highly toxic gas, and other irritating products.
- 5.c. Shielding gases used for arc welding can displace air and cause injury or death. Always use enough ventilation, especially in confined areas, to insure breathing air is safe.
- 5.d. Read and understand the manufacturer's instructions for this equipment and the consumables to be used, including the material safety data sheet (MSDS) and follow your employer's safety practices. MSDS forms are available from your welding distributor or from the manufacturer.
- 5.e. Also see item 1.b.

Mar '95



WELDING SPARKS can cause fire or explosion.

6.a. Remove fire hazards from the welding area. If this is not possible, cover them to prevent the welding sparks from starting a fire.

Remember that welding sparks and hot materials from welding can easily go through small cracks and openings to adjacent areas. Avoid welding near hydraulic lines. Have a fire extinguisher readily available.

- 6.b. Where compressed gases are to be used at the job site, special precautions should be used to prevent hazardous situations. Refer to "Safety in Welding and Cutting" (ANSI Standard Z49.1) and the operating information for the equipment being used.
- 6.c. When not welding, make certain no part of the electrode circuit is touching the work or ground. Accidental contact can cause overheating and create a fire hazard.
- 6.d. Do not heat, cut or weld tanks, drums or containers until the proper steps have been taken to insure that such procedures will not cause flammable or toxic vapors from substances inside. They can cause an explosion even though they have been "cleaned". For information, purchase "Recommended Safe Practices for the Preparation for Welding and Cutting of Containers and Piping That Have Held Hazardous Substances", AWS F4.1 from the American Welding Society (see address above).
- 6.e. Vent hollow castings or containers before heating, cutting or welding. They may explode.
- 6.f. Sparks and spatter are thrown from the welding arc. Wear oil free protective garments such as leather gloves, heavy shirt, cuffless trousers, high shoes and a cap over your hair. Wear ear plugs when welding out of position or in confined places. Always wear safety glasses with side shields when in a welding area.
- 6.g. Connect the work cable to the work as close to the welding area as practical. Work cables connected to the building framework or other locations away from the welding area increase the possibility of the welding current passing through lifting chains, crane cables or other alternate circuits. This can create fire hazards or overheat lifting chains or cables until they fail.
- 6.h. Also see item 1.c.

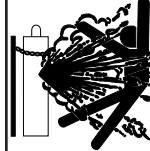

CYLINDER may explode if damaged.

7.a. Use only compressed gas cylinders containing the correct shielding gas for the process used and properly operating regulators designed for the gas and pressure used. All hoses, fittings, etc. should be suitable for the application and maintained in good condition.

- 7.b. Always keep cylinders in an upright position securely chained to an undercarriage or fixed support.
- 7.c. Cylinders should be located:
 - Away from areas where they may be struck or subjected to physical damage.
 - A safe distance from arc welding or cutting operations and any other source of heat, sparks, or flame.
- 7.d. Never allow the electrode, electrode holder or any other electrically "hot" parts to touch a cylinder.
- 7.e. Keep your head and face away from the cylinder valve outlet when opening the cylinder valve.
- 7.f. Valve protection caps should always be in place and hand tight except when the cylinder is in use or connected for use.
- 7.g. Read and follow the instructions on compressed gas cylinders, associated equipment, and CGA publication P-1, "Precautions for Safe Handling of Compressed Gases in Cylinders," available from the Compressed Gas Association 1235 Jefferson Davis Highway, Arlington, VA 22202.



FOR ELECTRICALLY powered equipment.

- 8.a. Turn off input power using the disconnect switch at the fuse box before working on the equipment.
- 8.b. Install equipment in accordance with the U.S. National Electrical Code, all local codes and the manufacturer's recommendations.
- 8.c. Ground the equipment in accordance with the U.S. National Electrical Code and the manufacturer's recommendations.

Mar '95

PRÉCAUTIONS DE SÛRETÉ

Pour votre propre protection lire et observer toutes les instructions et les précautions de sûreté spécifiques qui paraissent dans ce manuel aussi bien que les précautions de sûreté générales suivantes:

Sûreté Pour Soudage A L'Arc

1. Protégez-vous contre la secousse électrique:
 - a. Les circuits à l'électrode et à la pièce sont sous tension quand la machine à souder est en marche. Eviter toujours tout contact entre les parties sous tension et la peau nue ou les vêtements mouillés. Porter des gants secs et sans trous pour isoler les mains.
 - b. Faire très attention de bien s'isoler de la masse quand on soude dans des endroits humides, ou sur un plancher métallique ou des grilles métalliques, principalement dans les positions assis ou couché pour lesquelles une grande partie du corps peut être en contact avec la masse.
 - c. Maintenir le porte-électrode, la pince de masse, le câble de soudage et la machine à souder en bon et sûr état de fonctionnement.
 - d. Ne jamais plonger le porte-électrode dans l'eau pour le refroidir.
 - e. Ne jamais toucher simultanément les parties sous tension des porte-électrodes connectés à deux machines à souder parce que la tension entre les deux pinces peut être le total de la tension à vide des deux machines.
 - f. Si on utilise la machine à souder comme une source de courant pour soudage semi-automatique, ces précautions pour le porte-électrode s'appliquent aussi au pistolet de soudage.
2. Dans le cas de travail au dessus du niveau du sol, se protéger contre les chutes dans le cas où on recoit un choc. Ne jamais enrouler le câble-électrode autour de n'importe quelle partie du corps.
3. Un coup d'arc peut être plus sévère qu'un coup de soleil, donc:
 - a. Utiliser un bon masque avec un verre filtrant approprié ainsi qu'un verre blanc afin de se protéger les yeux du rayonnement de l'arc et des projections quand on soude ou quand on regarde l'arc.
 - b. Porter des vêtements convenables afin de protéger la peau de soudeur et des aides contre le rayonnement de l'arc.
 - c. Protéger l'autre personnel travaillant à proximité au soudage à l'aide d'écrans appropriés et non-inflammables.
4. Des gouttes de laitier en fusion sont émises de l'arc de soudage. Se protéger avec des vêtements de protection libres de l'huile, tels que les gants en cuir, chemise épaisse, pantalons sans revers, et chaussures montantes.
5. Toujours porter des lunettes de sécurité dans la zone de soudage. Utiliser des lunettes avec écrans latéraux dans les zones où l'on pique le laitier.
6. Eloigner les matériaux inflammables ou les recouvrir afin de prévenir tout risque d'incendie dû aux étincelles.
7. Quand on ne soude pas, poser la pince à un endroit isolé de la masse. Un court-circuit accidentel peut provoquer un échauffement et un risque d'incendie.
8. S'assurer que la masse est connectée le plus près possible de la zone de travail qu'il est pratique de le faire. Si on place la masse sur la charpente de la construction ou d'autres endroits éloignés de la zone de travail, on augmente le risque de voir passer le courant de soudage par les chaînes de levage, câbles de grue, ou autres circuits. Cela peut provoquer des risques d'incendie ou d'échauffement des chaînes et des câbles jusqu'à ce qu'ils se rompent.
9. Assurer une ventilation suffisante dans la zone de soudage. Ceci est particulièrement important pour le soudage de tôles galvanisées plombées, ou cadmiées ou tout autre métal qui produit des fumées toxiques.
10. Ne pas souder en présence de vapeurs de chlore provenant d'opérations de dégraissage, nettoyage ou pistolage. La chaleur ou les rayons de l'arc peuvent réagir avec les vapeurs du solvant pour produire du phosgène (gas fortement toxique) ou autres produits irritants.
11. Pour obtenir de plus amples renseignements sur la sûreté, voir le code "Code for safety in welding and cutting" CSA Standard W 117.2-1974.

PRÉCAUTIONS DE SÛRETÉ POUR LES MACHINES À SOUDER À TRANSFORMATEUR ET À REDRESSEUR

1. Relier à la terre le chassis du poste conformément au code de l'électricité et aux recommandations du fabricant. Le dispositif de montage ou la pièce à souder doit être branché à une bonne mise à la terre.
2. Autant que possible, l'installation et l'entretien du poste seront effectués par un électricien qualifié.
3. Avant de faire des travaux à l'intérieur de poste, la débrancher à l'interrupteur à la boîte de fusibles.
4. Garder tous les couvercles et dispositifs de sûreté à leur place.

Thank You

for selecting a **QUALITY** product by Lincoln Electric. We want you to take pride in operating this Lincoln Electric Company product
 ... as much pride as we have in bringing this product to you!

Please Examine Carton and Equipment For Damage Immediately

When this equipment is shipped, title passes to the purchaser upon receipt by the carrier. Consequently, Claims for material damaged in shipment must be made by the purchaser against the transportation company at the time the shipment is received.

Please record your equipment identification information below for future reference. This information can be found on your machine nameplate.

Product _____

Model Number _____

Code Number or Date Code _____

Serial Number _____

Date Purchased _____

Where Purchased _____

Whenever you request replacement parts or information on this equipment, always supply the information you have recorded above. The code number is especially important when identifying the correct replacement parts.

On-Line Product Registration

- Register your machine with Lincoln Electric either via fax or over the Internet.
 - For faxing: Complete the form on the back of the warranty statement included in the literature packet accompanying this machine and fax the form per the instructions printed on it.
 - For On-Line Registration: Go to our **WEB SITE at www.lincolnelectric.com**. Choose "Quick Links" and then "Product Registration". Please complete the form and submit your registration.

Read this Operators Manual completely before attempting to use this equipment. Save this manual and keep it handy for quick reference. Pay particular attention to the safety instructions we have provided for your protection. The level of seriousness to be applied to each is explained below:

WARNING

This statement appears where the information **must** be followed **exactly** to avoid **serious personal injury** or **loss of life**.

CAUTION

This statement appears where the information **must** be followed to avoid **minor personal injury** or **damage to this equipment**.

MASTER TABLE OF CONTENTS FOR ALL SECTIONS

	Page
<hr/>	
Installation	Section A
Technical Specifications	A-1
Identify and Locate Components	A-2
Select Suitable Location	A-3
Output Connections	A-3
Input Connections	A-6
Code Requirements	A-6
<hr/>	
Operation	Section B
Safety Precautions	B-1
General Description	B-1
Design Features	B-1
Welding Capability	B-2
Limitations	B-2
Controls and Settings	B-2
Welding Operations	B-3
Overload Protection	B-6
Application Chart	B-7
<hr/>	
Accessories	Section C
Accessories	C-1
Replacement Parts	C-2
<hr/>	
Maintenance	Section D
Safety Precautions	D-1
Items Requiring No Maintenance	D-1
Routine Maintenance	D-1
Gun and Cable Maintenance	D-2
Component Replacement Procedures	D-3
Changing Liner	D-4
Gun Handle Parts	D-4
<hr/>	
Troubleshooting	Section E
Safety Precautions	E-1
How to Use Troubleshooting Guide	E-1
Troubleshooting Guide	E-2 THRU E-4
<hr/>	
Wiring Diagrams	Section F
SP-135T Wiring Diagram	F-1
<hr/>	
Parts Lists	P451 Series, P202-E
<hr/>	

TECHNICAL SPECIFICATIONS – SP-135T

INPUT – SINGLE PHASE ONLY		
<u>Standard Voltage/Frequency</u> 120V/60Hz	<u>Input Current</u> 20 Amps - Rated Output	
RATED OUTPUT		
<u>Duty Cycle</u> 20% Duty Cycle	<u>Amps</u> 90	<u>Volts at Rated Amperes</u> 19
OUTPUT		
Welding Current Range 25-135 Amps	Maximum-Open Circuit Voltage 29V	Wire Speed Range 50 - 300 in/min (1.3 - 7.6 m/min)

RECOMMENDED INPUT CABLE AND FUSE SIZES					
Output Mode	Input Voltage	Fuse or Breaker Size ¹	Input Amps	Power Cord	Extension Cord
RATED	120V/60Hz	20 Amp	20	15 Amp, 125V, Three Prong Plug (NEMA Type 5-15P)	Three Conductor #14 AWG (2.1 mm ²) or Larger Up to 25 Ft. (7.6 mm) Three Conductor #12 AWG (3.3 mm ²) or Larger Up to 50 Ft. (15.2 mm)

PHYSICAL DIMENSIONS			
Height	Width	Depth	Weight
12.0 in	9.75 in	16.5 in	48 lbs
305 mm	248 mm	419 mm	21.8 kg

¹If connected to a circuit protected by fuses use Time Delay Fuse marked "D".

SP-135T



Read entire installation section before starting installation.

SAFETY PRECAUTIONS

⚠ WARNING



ELECTRIC SHOCK can kill.

- Only qualified personnel should perform this installation.
- Only personnel that have read and understood the SP-135T Operating Manual should install and operate this equipment.
- Machine must be plugged into a receptacle which is grounded per any national, local or other applicable electrical codes.
- The SP-135T power switch is to be in the OFF ("O") position when installing work cable and gun and when connecting power cord to input power.

IDENTIFY AND LOCATE COMPONENTS

If you have not already done so, unpack the SP-135T from its carton and remove all packing material around the SP-135T. Remove the following loose items from the carton (see Figure A.1):

1. SP-135T
2. Gun and cable assembly¹⁾
3. Literature and miscellaneous including:
 - a) This operating manual
 - b) 6 extra .023"-.025" (0.6 mm) contact tips
 - c) Hex key wrench for removal of drive roll.
4. 10 ft (3.0 m) work cable.
5. Work clamp.
6. 2 LB. Sample Spool of Super Arc L-56 .025 MIG Wire.
7. Handshield with filter plate and lens.
8. Adjustable mixed-Gas Regulator & Hose.

For available options and accessories refer to the Accessories Section of this manual.

¹⁾ As shipped from the factory, the SP-135T gun liner is ready to feed .023" (0.6 mm) -.035 (0.9 mm) wire. The contact tip is sized for .023"-.025" (0.6 mm) wire feeding.

FIGURE A.1

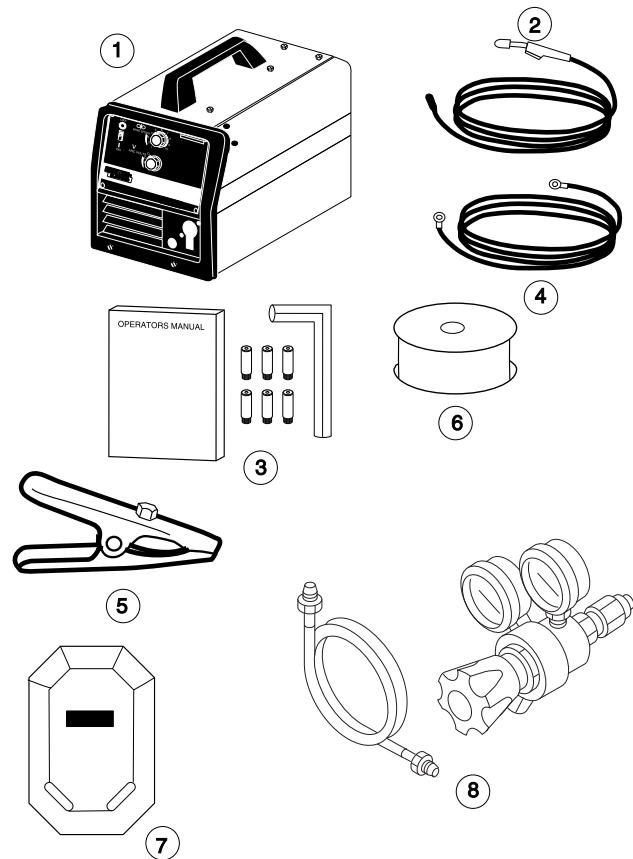

SELECT SUITABLE LOCATION

Locate the welder in a dry location where there is free circulation of clean air into the louvers in the back and out the front of the unit. A location that minimizes the amount of smoke and dirt drawn into the rear louvers reduces the chance of dirt accumulation that can block air passages and cause overheating.

STACKING

SP-135T's cannot be stacked.

TILTING

Each machine must be placed on a secure, level surface, or on a recommended cart. The machine may topple over if this procedure is not followed.

OUTPUT CONNECTIONS

Refer to Figure A.2.

1. Work Cable Access Hole.
2. Gun Cable and Control Lead Access Hole.
3. Connector Block.
4. Gun Trigger Lead Connectors.
5. Positive (+) and negative (-) output terminals.
6. Wire Feed Gearbox.
7. Cable Hanger.
8. Thumbscrew.

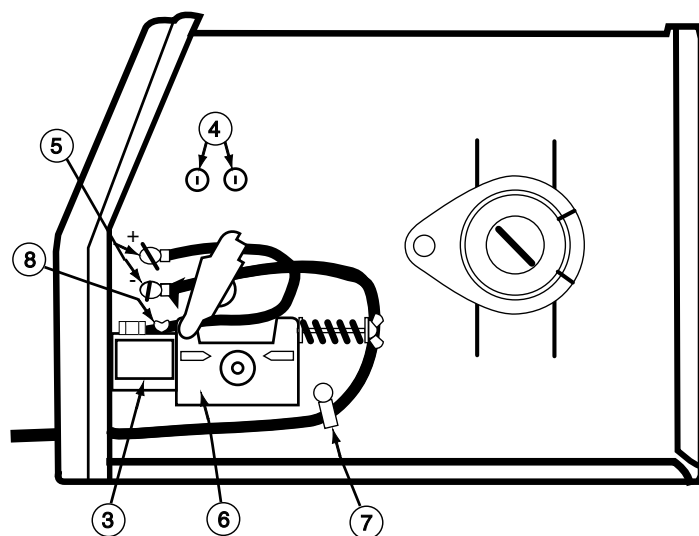
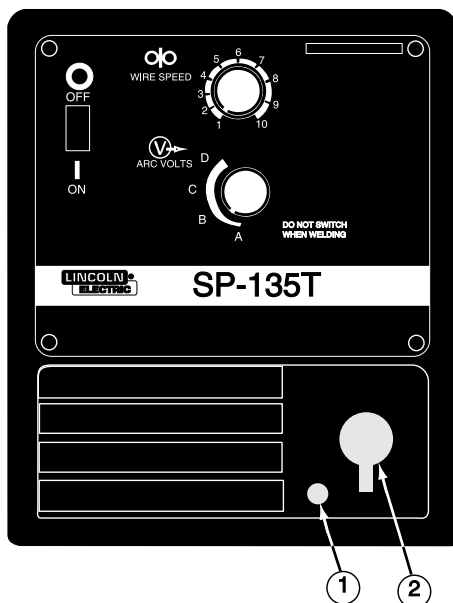

FIGURE A.2

SP-135T
LINCOLN[®]
 ELECTRIC

Work Clamp Installation

Attach the work clamp per the following:

1. Unplug the machine or turn the power switch to the "OFF" position.
2. Insert the work cable terminal lug with the larger hole through the strain relief hole in the work clamp as shown in Figure A-3.
3. Fasten securely with the bolt and nut provided.

FIGURE A.3

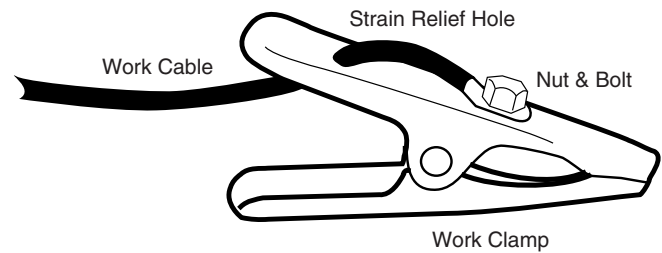

Work Cable Installation

Refer to Figure A.2.

1. Open the wire feed section door on the right side of the SP-135T.
2. Pass the end of the work cable that has the terminal lug with the smaller hole through the Work Cable Access Hole (1) in the case front.
3. Route the cable under and around the back of the Wire Feed Gearbox (6).
4. **For GMAW Only:** Refer to Figure A.2. As delivered, the machine is connected for positive electrode polarity. This is the appropriate configuration for the GMAW (MIG) process. To complete installation, use the provided wing nut to connect the work cable's terminal lug to the negative (-) output terminal (5) located above the Wire Feed Gearbox (6). Make sure that both wing nuts are tight.
5. **For Innershield Only:** Refer to Figure A.4. To wire for negative polarity (required for the Innershield process), connect the short cable attached to the connector block (1) to the negative (-) output terminal (2) and the work cable (3) to the positive (+) terminal (4).

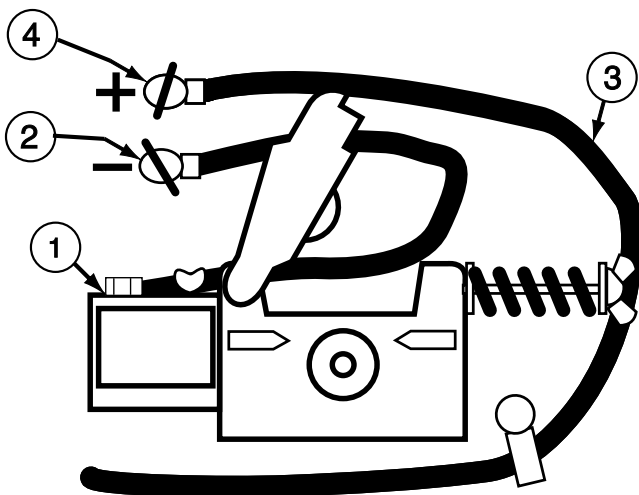

FIGURE A.4

GUN INSTALLATION

As shipped from the factory, the SP-135T is ready to feed .023" – .025" (0.6 mm) solid wire. If .030-.035"(0.8-0.9mm) solid wire is to be used, change the contact tip to the appropriate size.

NOTE: If .035" (0.9 mm) Innershield flux-cored wire is to be used, assemble the gasless nozzle and, 035" contact tip on to gun and reverse drive roll.

Connecting Gun Cable to the SP-135T

1. Refer to Figure A.2. Unplug the machine or turn power switch to the OFF "O" position.
2. Pass the insulated terminals of the gun trigger control leads, one at a time, through the Gun Cable and Control Lead Access Slot (2) in the case front. The leads are to be routed under the Wire Feed Gearbox (6) and through the Cable Hanger (7) on the inner panel.
3. Insert the connector on the gun conductor cable through the Gun Cable Access Hole (2) in the SP-135T case front. Make sure the connector is all the way in the brass connector block. Unscrew thumb-screw on the connector block a few turns if gun connector will not insert fully. Rotate the connector so control leads are on the underside and tighten the Thumbscrew (8) in the connector block.
4. Connect the gun trigger control lead terminals to the two insulated 1/4" (6.4 mm) tab terminal connector bushings located below the "Gun Trigger Connection" decal in the wire feed section (4). Either lead can go to either connector. Form the leads so that they are as close as possible to the inside panel.

⚠ CAUTION

If the gun trigger switch being used is other than that supplied with the SP-135T, the switch must be a normally open, momentary switch. The terminals of the switch must be insulated from the welding circuit. Malfunction of the SP-135T may result if this switch shorts to the SP-135T welding output circuit or is common to any electrical circuit other than the SP-135T trigger circuit.

GAS CONNECTION

When using the GMAW process, a cylinder of shielding gas, must be obtained. For more information about selecting gas cylinders for use with the SP-135T refer to the ACCESSORIES section.

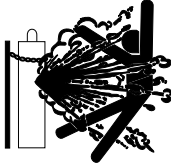
⚠ WARNING

CYLINDER may explode if damaged. Keep cylinder upright and chained to support

- Keep cylinder away from areas where it may be damaged.
- Never lift welder with cylinder attached.
- Never allow welding electrode to touch cylinder.
- Keep cylinder away from welding or other live electrical circuits.

⚠ WARNING

BUILDUP OF SHIELDING GAS may harm health or kill.

- Shut off shielding gas supply when not in use.
- **SEE AMERICAN NATIONAL STANDARD Z-49.1, "SAFETY IN WELDING AND CUTTING" PUBLISHED BY THE AMERICAN WELDING SOCIETY.**

1. Chain the cylinder to a wall or other stationary support to prevent the cylinder from falling over. Insulate the cylinder from the work circuit and earth ground. Refer to Figure A.5.

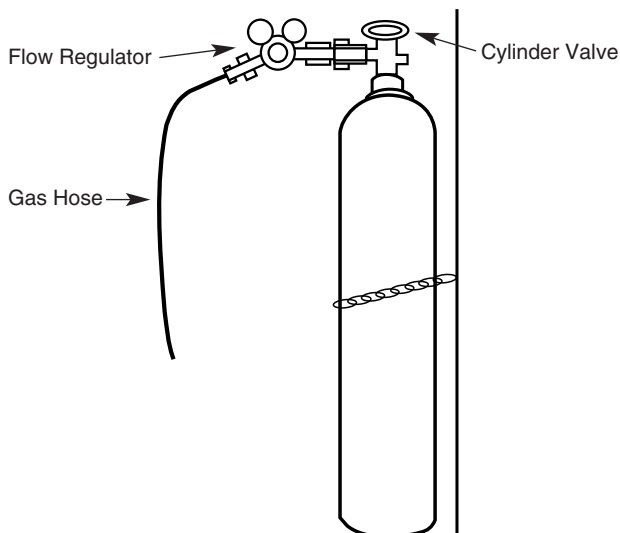

FIGURE A.5

2. With the cylinder securely installed, remove the cylinder cap. Stand to one side away from the outlet and open the cylinder valve very slightly for an instant. This blows away any dust or dirt which may have accumulated in the valve outlet.

⚠ WARNING

BE SURE TO KEEP YOUR FACE AWAY FROM THE VALVE OUTLET WHEN "CRACKING" THE VALVE. Never stand directly in front of or behind the flow regulator when opening the cylinder valve. Always stand to one side.

3. Attach the flow regulator to the cylinder valve and tighten the union nut securely with a wrench.

NOTE: If connecting to 100% CO₂ cylinder, make certain the plastic washer is seated in the fitting that attaches to the CO₂ cylinder.

4. Refer to Figure A.6. Attach one end of inlet gas hose to the outlet fitting of the flow regulator and tighten the union nut securely with a wrench. Connect the other end to the SP-135T Gas Solenoid Inlet Fitting (5/8-18 female threads — for CGA — 032 fitting). Make certain the gas hose is not kinked or twisted.

INPUT CONNECTIONS

Refer to Figure A.6.

The SP-135T has a power input cable located on the rear of the machine.

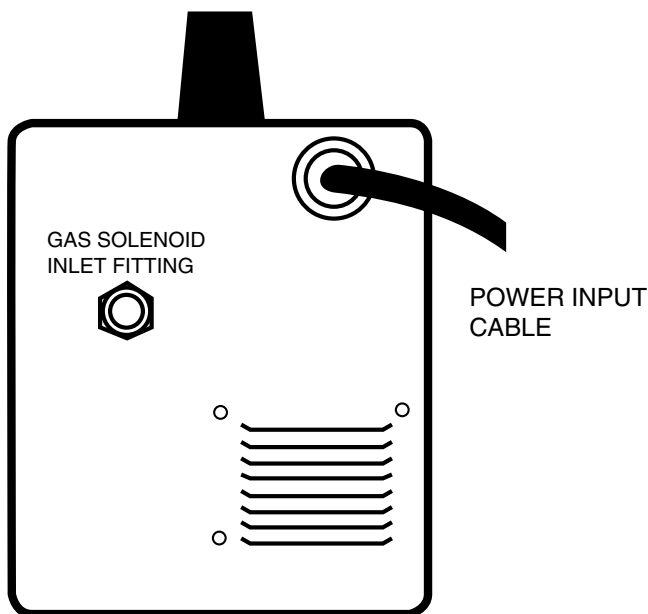

FIGURE A.6

Requirements For Rated Output

A power cord with a 15 amp, 125 volt, three prong plug (NEMA Type 5-15P) is factory installed on the SP-135T. Connect this plug to a mating grounded receptacle which is connected to a 20 amp branch circuit with a nominal voltage rating of 115 to 125 volts, 60 Hertz, AC only.

The rated output with this installation is 90 amps, 19 Volts, 20% duty cycle (2 minutes of every 10 minutes used for welding).



CAUTION

Do not connect the SP-135T to an input power supply with a rated voltage that is greater than 125 volts.

Do not remove the power cord ground prong.

CODE REQUIREMENTS FOR INPUT CONNECTIONS



WARNING

This welding machine must be connected to a power source in accordance with applicable electrical codes.

The National Electrical Code provides standards for amperage handling capability of supply conductors based on duty cycle of the welding source.

If there is any question about the installation meeting applicable electrical code requirements, consult a qualified electrician.

Read entire operation section before operating the SP-135T.

⚠ WARNING



ELECTRIC SHOCK can kill.

- Do not touch electrically live parts or electrode with skin or wet clothing. Insulate yourself from work and ground.
- Always wear dry insulating gloves.



FUMES AND GASES can be dangerous.

- Keep your head out of fumes.
- Use ventilation or exhaust to remove fumes from breathing zone.

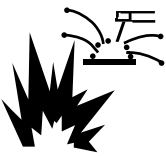

WELDING SPARKS can cause fire or explosion.

- Keep flammable material away.
- Do not weld on closed containers.



ARC RAYS can burn eyes and skin.

- Wear eye, ear and body protection.

Observe all safety information throughout this manual.

GENERAL DESCRIPTION

The SP-135T is a complete semiautomatic constant-voltage DC wire feeder / power source arc welder. It has been designed for workshop, hobby, automotive and light maintenance. Included is a tap-switch controlled, single phase constant voltage transformer / rectifier power source and a wire feeder welding gun for feeding .023 - .025" (0.6 mm) through .030" (0.8 mm) solid steel electrode. An optional kit is available for feeding .035" (0.9 mm) Innershield[®] NR-211-MP flux-cored wire.

The SP-135T is ideally suited for individuals having access to 120 volt AC input power, and wanting the ease of use, quality and dependability of both gas metal arc welding or GMAW (also known as MIG welding) and the Innershield electrode process (self shielded flux cored or FCAW). The SP-135T is a rugged and reliable machine that has been designed for dependable service and long life.

RECOMMENDED PROCESSES

The SP-135T can be used for welding mild steel using the Gas Metal Arc Welding (GMAW or MIG, Metal Inert Gas) single pass process, which requires a supply of shielding gas, or the flux-cored arc welding (FCAW) process using Innershield[®] electrode wire. The SP-135T is configured for use with the GMAW process as delivered from the factory.

OPERATIONAL CONTROLS

The SP-135T has the following controls as standard: Control Power ON/OFF Switch, Voltage Control, Wire Speed Control, Trigger Switch, and a Circuit Breaker.

DESIGN FEATURES

- Operates on 120 volt input
- "Cold electrode" until gun trigger is pressed for an added measure of safety.
- Overload protection — incorporates both a thermostat and a circuit breaker.
- Quality wire drive with electronic overload protection.
- "Quick Release" idle roll pressure arm is easily adjusted.
- Reversible, dual groove drive roll. Drive roll will feed .023 – .025" (0.6 mm) and .030" - .035" (0.8 - 0.9 mm) diameter wire.

- No external shielding gas is required when used with Lincoln Innershield .035" (0.9 mm) NR[®]-211-MP electrode.
- Accommodates both 4" (100 mm) diameter and 8" (200 mm) diameter spools of wire.

5. Gun Trigger - Activates welding output, wire feed, and gas solenoid operation. Releasing the trigger deactivates welding and simultaneously activates the "burnback" function so that the welding wire does not stick in the weld puddle.

WELDING CAPABILITY

The SP-135T is rated at 90 amps, 19 volts, at 20% duty cycle on a ten minute basis. It is capable of higher output currents at lower duty cycles.

LIMITATIONS

Arc Gouging cannot be performed with the SP-135T. The SP-135T is not recommended for pipe thawing or TIG welding.

CONTROLS AND SETTINGS

Refer to Figure B.1a.

1. Control Power ON/OFF Switch — When the power is on the fan motor will run and air will be exhausted out the louvers in the front of the machine. The welding output and wire feeder remain off until the gun trigger is pressed.
2. Wire Speed Control — Controls the wire feed speed from 50 – 300 in /min (1.3 – 7.6 m/min). The control can be preset on the dial to the setting specified on the SP-135T Application Chart located on the inside of the wire feed section door.
3. Voltage Control — A 4-position tap selector switch gives full range adjustment of power source output voltage. Do not switch while welding.

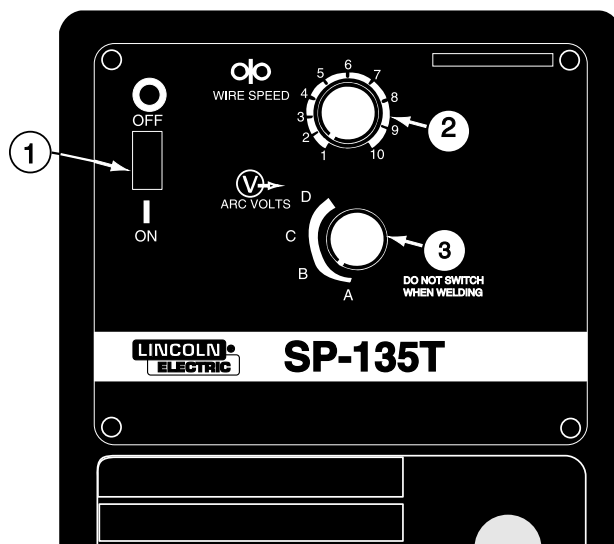
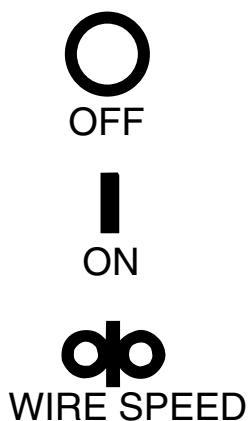

FIGURE B.1a

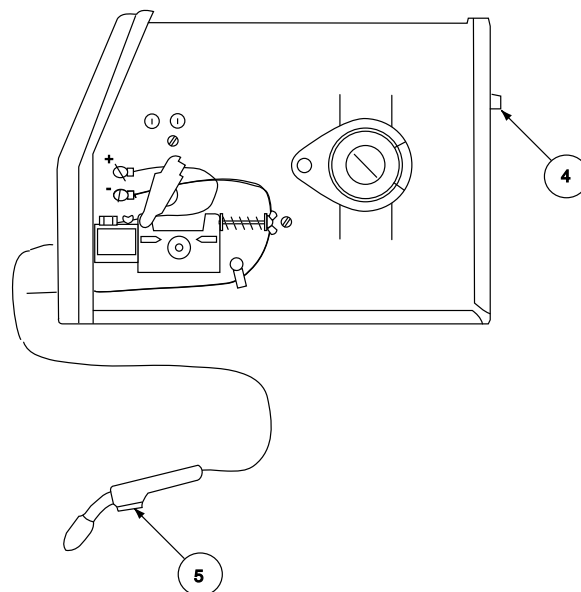

FIGURE B.1b

Refer to Figure B.1b.

4. Circuit Breaker – Protects machine from damage if maximum output is exceeded. Button will extend out when tripped (Manual reset).

WELDING OPERATIONS

SEQUENCE OF OPERATION

Wire Loading

Refer to Figures B.2 and B.3.

The machine power switch should be turned to the OFF ("O") position before working inside the wire feed enclosure.

The welder is shipped from the factory ready to feed 8" (200 mm) diameter spools with 2.2" (56 mm) maximum width. These spools fit on a 2" (51 mm) diameter spindle that has a built in, adjustable friction brake to prevent overrun of the spool and excess slack in the wire.

Note: When loading and removing the 8" Spools make sure that the wing nut (inside the wire spool spindle hub) is turned 90° from the wire spool spindle locking tab. If the wing nut is positioned in line with the locking tab, the tab cannot be depressed to load or unload the wire spool.

FIGURE B.2

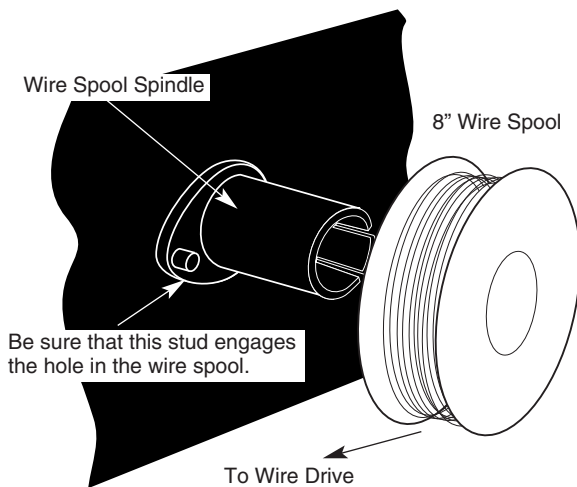

Wire Spool must be pushed all the way on the spindle so that the spindle's tab will hold it in place. The Wire Spool will rotate clockwise when wire is dereeled.

Load an 8" (200 mm) diameter spool on the wire spool spindle shown in Figure B.2.

To use 4" (100 mm) diameter spools, the 2" (50 mm) diameter spindle must be removed (See Figure B.3). Remove the wing nut and spacer at the end of the shaft and remove the outside plastic wire spool spindle. The spindle can be stored in the wire feed compartment. A 4" (100 mm) diameter spool is mounted directly on the 5/8" (16 mm) diameter shaft and held in place with the previously removed hardware. Also make certain the start end of the wire, which may protrude through the side of the spool does not contact any metallic case parts.

FIGURE B.3

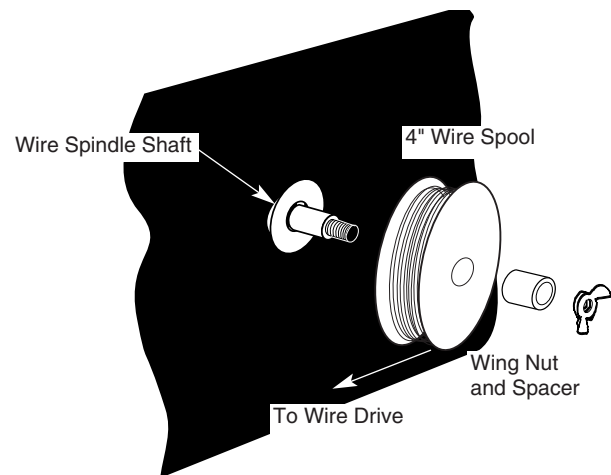

Friction Brake Adjustment

With wire spool installed on the spindle shaft and the wing nut loose, turn the spool by hand while slowly tightening the wing nut until a light drag is felt. Tighten the wing nut an additional 1/4 turn.

Note: When properly adjusted, the brake should provide only enough drag to prevent overrun of the spool and excess slack in the wire. Too much drag may result in wire feeding problems, and may cause premature wear of wire drive system components.

Wire Threading

Refer to Figure B.4

1. Release the Spring Loaded Pressure Arm (1) rotate the Idle Roll Arm (2) away from the Wire Feed Drive Roll (3). Ensure that the groove size in the feeding position on the drive roll matches the wire size being used.
2. Carefully detach the end of the wire from the spool. To prevent the spool from unwinding, maintain tension on the wire until after step 5.
3. Cut the bent portion of wire off and straighten the first 4" (100 mm).
4. Thread the wire through the In-going guide tube (4), over the drive roll (3), and into the out-going guide tube (5).
5. Close the idle roll arm (2) and latch the spring loaded pressure arm (1) in place. Rotate the spool counterclockwise if required in order to take up extra slack in the wire.
6. The idle roll pressure adjustment wing nut is factory set to approximately five full turns from where the wing nut first engages the threads of the pressure arm (1). If feeding problems occur because the wire is flattened excessively, turn the pressure adjustment counter-clockwise to reduce distortion of the wire. Slightly less pressure may be required when using 0.023 – 0.025" (0,6 mm) wire. If the drive roll slips while feeding wire, the pressure should be increased until the wire feeds properly.

WARNING

When inching the welding wire, the drive rolls, the gun connector block and the gun contact tip are electrically energized relative to work and ground and remain energized for several seconds after the gun trigger is released.

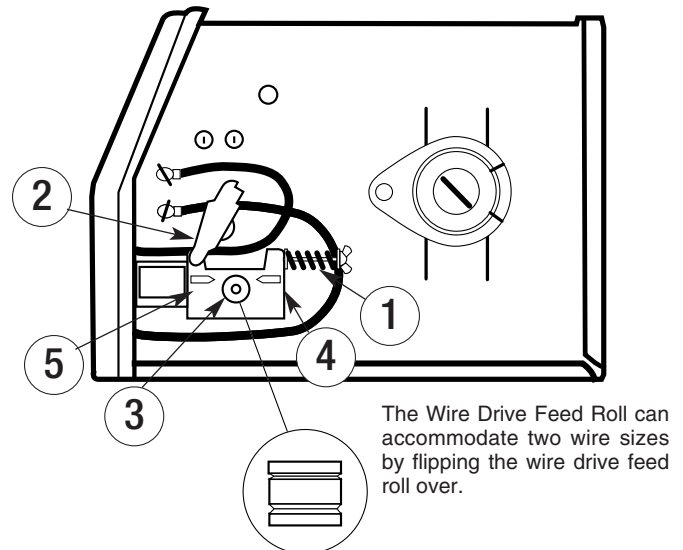

FIGURE B.4

7. Refer to Figure B.5. Remove gas nozzle and contact tip from end of gun.
 8. Turn the SP-135T ON ("I").
 9. Straighten the gun cable assembly.
 10. Depress the gun trigger switch and feed welding wire through the gun and cable. (Point gun away from yourself and others while feeding wire.) Release gun trigger after wire appears at end of gun.
- NOTE:** If the wire will not feed smoothly, or if the wire feed motor shuts off unexpectedly, see "FEEDING PROBLEMS" section of the "TROUBLESHOOTING GUIDE" in this manual.
11. Turn the SP-135T OFF ("O").
 12. Replace contact tip and gas nozzle.
 13. Refer to Figure B-6. Cut the wire off 3/8" – 1/2" (10 – 13 mm) from the end of the tip. The SP-135T is now ready to weld.

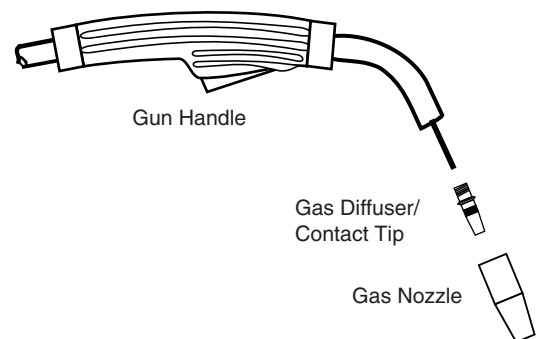

FIGURE B.5

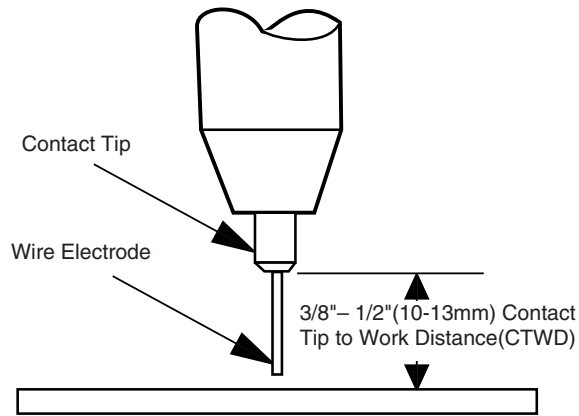

FIGURE B.6

Making A Weld

1. See "Process Guidelines" in this section for selection of welding wire and shielding gas and for range of metal thicknesses that can be welded.
2. See the Application chart on the inside of the wire feed compartment door for information on setting the SP-135T controls. Refer to Table B.1 for aluminum and stainless wire.
3. Set the Voltage ("V") and Wire Speed ("olo") controls to the settings suggested for the welding wire and base metal thickness being used, refer to Applications chart on the inside of the wire drive compartment door.
4. Check that the polarity is correct for the welding wire being used and that the gas supply, if required, is turned on.
5. When using Innershield electrode, remove the gas nozzle and install the gasless nozzle. This will improve visibility of the arc and protect the gas diffuser from weld spatter. Refer to the MAINTENANCE section for details on nozzle replacement.

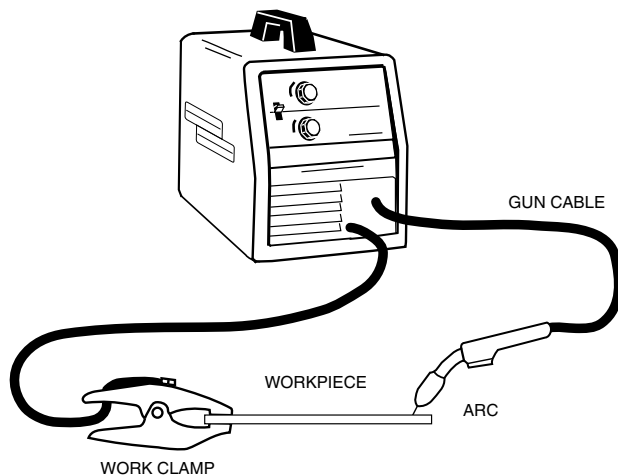

FIGURE B.7

6. Refer to Figure B.7. Connect work clamp to metal to be welded. Work clamp must make good electrical contact to the workpiece. The workpiece must also be grounded as stated in "Arc Welding Safety Precautions" in the beginning of this manual.
7. Position gun over joint. End of wire may be lightly touching the work.
8. Lower welding helmet, close gun trigger, and begin welding. Hold the gun so the contact tip to work distance is about 3/8 inch (10 mm).
9. To stop welding, release the gun trigger and then pull the gun away from the work after the arc goes out.
10. When no more welding is to be done, close valve on gas cylinder (if used), momentarily operate gun trigger to release gas pressure, and turn off the SP-135T.

Cleaning Tip And Nozzle

Clean the contact tip and nozzle to avoid arc bridging between the nozzle and contact tip which can result in a shorted nozzle, poor welds and an overheated gun. Hint: Anti-stick spray or gel, available from a welding supply distributor, may reduce buildup and aid in spatter removal.

PROCESS GUIDELINES

The SP-135T can be used for welding mild steel using the GMAW, single pass, process which requires a supply of shielding gas or it can be used for the self-shielded, Innershield[®] process (FCAW).

The recommended gases and electrodes for GMAW are welding grade CO₂ gas or an argon-CO₂ blended gas (75 to 80% argon and 25 to 20% CO₂) and .025" (0.6 mm) diameter Lincoln Super Arc L-56 mild-steel welding wire, supplied on 12-1/2 lb (5.7 kg) spools.

The recommended electrode for the self-shielded process is .035" (0.9 mm) diameter Lincoln Innershield[®] NR-211-MP on 10 lb (4.5 kg) spools. This electrode can be used for all position welding of 20 gauge (1.0 mm) through 5/16" (8 mm) steel. Thickness of 1/4" (6 mm) and 5/16" (8 mm) require multiple passes. This wire can also be used for the welding of galvanized coated sheet metal.

The SP-135T is suitable for .035" aluminum wire and .030" stainless wire. Refer to Table B.1 for recommended procedure settings (requires K499 Argon Regulator Kit).

TABLE B.1

Process	Welding Wire	Shielding Gas	Voltage/Wire Speed					
			22 ga	16 ga	12 ga	1/8"	3/16"	1/4"
MIG DC+	.035 Dia(0.9mm) 4043 Aluminum Wire	100% Argon	B-4.5	B-8.5	D-10	NR*	NR*	NR*
	.030 Dia 308L Stainless Steel Wire	98% Argon/ 2% Oxygen	A-3	C-6	D-7.5	D-7.5		

*NR (Not Recommended)

CHANGING MACHINE OVER TO FEED OTHER WIRE SIZES

The SP-135T is shipped from the factory ready to feed .023"-.025" (0.6 mm) diameter wire. To operate the SP-135T with other sizes of wire, it may be necessary to change the contact tip and change the drive roll over to other sizes. Refer to Changing the Contact Tip and Changing the Drive Roll, in the MAINTENANCE section, for specific information on these procedures.

WELDING WITH GMAW (MIG)

Shielding Gas

When using the GMAW process, obtain and install a gas regulator and hose kit; K463 (for CO₂) or K499 (Argon mixed) gas regulator and hose kit.

- For CO₂, open the cylinder very slowly. For argon-mixed gas, open cylinder valve slowly a fraction of a turn. When the cylinder pressure gauge pointer stops moving, open the valve fully.

- If using a regulator with an adjustable flow meter, press the gun trigger and adjust the flow to give 15 – 20 cubic ft per hour (CFH) (7 – 10 l/min) [use 20 – 25 CFH (10 – 12 l/min) when welding out of position or in a drafty location for CO₂]. For argon mixed gas, press the gun trigger to release gas pressure, and adjust the flow to give 25 – 30 CFH (12 – 14 l/min).
- Keep the cylinder valve closed, except when using the SP-135T. When finished welding:
 - Close the cylinder valve to stop gas flow.
 - Press the gun trigger briefly to release the pressure in the gas hose.
 - Turn off the SP-135T.

WELDING WITH FCAW (Innershield)

When using the FCAW process, the correct drive roll and electrode polarity must be used. See Work Cable Installation in INSTALLATION section for changing the polarity.

Innershield welding kit K549-1 (for .035" / 0.9mm) is also available.

OVERLOAD PROTECTION

Output Overload

The SP-135T is equipped with a circuit breaker and a thermostat which protects the machine from damage if maximum output is exceeded. The circuit breaker button will extend out when tripped. The circuit breaker must be manually reset.

Thermal Protection

The SP-135T has a rated output duty cycle of 20%. If the duty cycle is exceeded, a thermal protector will shut off the output until the machine cools to a reasonable operating temperature. This is an automatic function of the SP-135T and does not require user intervention. The fan continues to run during cooling.

Electronic Wire Drive Motor Protection

The SP-135T has built-in protection for wire drive motor overload.



SUGGESTED SETTINGS FOR WELDING

FOR STAINLESS STEEL AND ALUMINUM SETTINGS - SEE MANUAL



PROCESS	WELDING WIRE	SHIELDING GAS	STEEL THICKNESS											
			24 ga .024 in. 0.60 mm	22 ga .030 in. 0.80 mm	20 ga .036 in. 1.0 mm	18 ga .048 in. 1.2 mm	16 ga .060 in. 1.6 mm	14 ga .075 in. 2.0 mm	12 ga .105 in. 2.5 mm	10 ga .135 in. 3.5 mm	3/16 in. 5.0 mm	1/4 in. 6.0 mm		
MIG DC(+)	.025 in. (0.6 mm) DIA. SOLID STEEL WIRE LINCOLN WELD® L-56	CO ₂	B-2.5	B-2.5	B-3	B-3	B-3	C-4	D-5					
		C20 or C25 (75-80% Argon, 25-20% CO ₂)	A-2.5	A-2.5	A-2.5	B-3.5	C-5	D-7						
GASLESS FLUX-CORED DC(-)	.030 in. (0.8 mm) DIA. SOLID STEEL WIRE LINCOLN WELD® L-56	CO ₂			B-2	C-2.5	D-3	D-3.5						
		C20 or C25 (75-80% Argon, 25-20% CO ₂)			B-2.5	B-2.5	C-3	D-4.5						
	.035 in. (0.9 mm) DIA. INNERSHIELD NR®-211-MP	NONE			B-1.5	B-2	B-2	C-2.5	D-3	D-3.5				

OUTPUT POLARITY

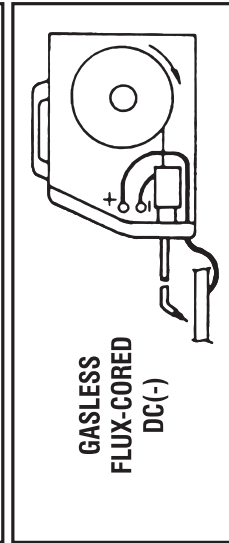
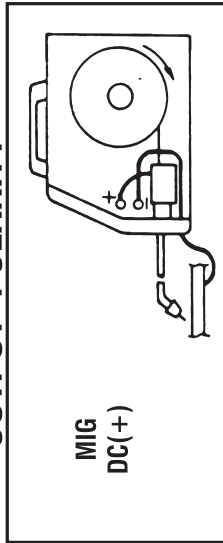

DRIVE ROLL ORIENTATION

ALIGN GROOVE WITH CENTER OF GUIDE TUBES, SECURE DRIVE ROLL WITH SET SCREW CENTERED ON FLAT	MIG DC(+)	GASLESS FLUX-CORED DC(-)
	.025 (0.6 mm) DIA. SOLID STEEL WIRE	.035 (0.9 mm) DIA. INNERSHIELD NR®-211-MP
	For best performance Install .023/.030 liner.	

Be sure to read and understand the warnings on this welding machine and the section on ARC WELDING SAFETY PRECAUTIONS in the Operating Manual. Because design, fabrication, assembly and welding variables affect the results obtained in applying this type of information, the serviceability of a product or assembly is the responsibility of the builder/user.

WARNING: WHEN THE WELDING POWER SOURCE IS ON AND THE GUN TRIGGER DEPRESSED, FEED ROLLS, WIRE REEL AND ELECTRODE ARE ELECTRICALLY HOT.

AVERTISSEMENT: LORSQUE LE POSTE DE SOUDAGE EST BRANCHE ET QUE LA DETENTE DU PISTOLET EST ENFONCEE, LES ROULEAUX D'ENTRAÎNEMENT, LE DEVIDOIR ET L'ELECTRODE SONT MIS SOUS TENSION.



L11730 SP-135T

MAGNUM™ 100L
gun and cable
Consumable
Parts

Contact Tips - Standard Duty	Part No.	For Wire Size
	S19726-1	.025 in. (0.6mm) .030 in. (0.8mm) .035 in. (0.9mm)
	-2	
	-3	

Contact Tips - Tapered	Part No.	For Wire Size
	S20278-1	.025 in. (0.6mm) .030 in. (0.8mm) .035 in. (0.9mm)
	-2	
	-3	

Gas Nozzle - Tip Flush	Part No.	Opening I.D.
	M16294	1/2 in. (12.7mm)

Gas Nozzles - Tip Recessed	Part No.	Opening I.D.
	M16684 M16684-1 M16684-2	3/8 in. (9.5mm) 1/2 in. (12.7mm) 5/8 in. (15.9mm)

Gasless Nozzle	Part No. M16418
Gas Diffuser	Part No. S19728

OPTIONAL ACCESSORIES

1. **K549-1 .035" (0.9 mm) Innershield® Welding Kit** — Includes a contact tip, a gasless nozzle and a .035/.035" (0.8-0.9mm) cable liner to permit the Magnum™ 100L gun and cable to use .035" (0.9 mm) diameter flux-cored electrode. The fitting on the end of the liner is stenciled with the maximum rated wire size (.045"/1.2 mm). Also included is a 10 lb. (4.5 kg.) spool of .035" (0.9 mm) Innershield NR-211-MP.

See "Innershield (FCAW) Conversion" in this section for installation instructions and MAINTENANCE section for proper feeding component configuration and installation.

2. **K664-2 Aluminum Feeding Kit** — This kit required for welding with .035 Aluminum wire. Included with this kit are a drive roll, liner and contact tip. **It is important when changing between welding with steel wire and aluminum to exchange these components due to the lubricant applied to steel wire. Failure to do so may result in contaminated welds when welding aluminum.**
3. **K520 Utility Cart** — Designed to transport the Lincoln family of small welders. Has provisions for mounting a single gas cylinder. Has front casters and large rear wheels. Handle height is easily adjustable. Bottom tray provided for tools and accessories. Easy assembly required; takes less than 15 minutes.
4. **K586-1 Deluxe Adjustable Gas Regulator & Hose Kit** — Accommodates CO₂ or mixed Gas Cylinders.

INNERSHIELD (FCAW) CONVERSION

Several changes are needed to convert the unit for operation with the Innershield (FCAW) process. The K549-1 or K549-2 Innershield Kits include all the necessary accessories for this conversion and are provided for this purpose. The following conversions should be made using the contents of this kit:

1. Change the output polarity to DC(-). See "Work Cable Installation" in Installation section for details.
2. Install proper drive roll for the wire size selected. See "Changing Drive Roll" in Maintenance section for details.
3. Install the proper gun liner* and tip for the wire size selected. See "Component Replacement" in Maintenance section for details.
4. Remove gas nozzle (if installed) and install gasless nozzle. To remove, simply unscrew.
5. Load wire into machine and thread into gun and cable per "Welding Wire Loading" section.

* The factory installed Gun Liner will feed .025-.035 (0.6-0.9mm) wire.

REPLACEMENT PARTS

Complete Gun and Cable Assembly
L8311-6 (K530-4)

Contact Tip .025" (0.6 mm)
KP2039-1B1

Contact Tip .030" (0.8 mm)
KP2039-2B1

Contact Tip .035" (0.9 mm)
KP2039-3B1

Contact Tip-Tapered .025" (0.6 mm)
KP2052-1B1

Contact Tip-Tapered .030" (0.8 mm)
KP2052-2B1

Contact Tip-Tapered .035" (0.9 mm)
KP2052-3B1

Liner .023 - .035" (0.6 - 0.9 mm)
KP1937-3

Gas Diffuser
KP2040-1

Gas Nozzle
KP1938-1

**Gas Nozzle-Tip Recessed 3/8" (9.5 mm)
Opening I.D.**
KP1942-1

**Gas Nozzle-Tip Recessed 1/2" (12.7 mm)
Opening I.D.**
KP1942-2

**Gas Nozzle-Tip Recessed 5/8" (15.9 mm)
Opening I.D.**
KP1942-3

Spot Welding Nozzle
KP1956-1

Gasless Nozzle (Innershield Only)
KP1939-1

MAINTENANCE

SAFETY PRECAUTIONS

WARNING



ELECTRIC SHOCK can kill.

- **Disconnect input power by removing plug from receptacle before working inside SP-135T. Use only grounded receptacle. Do not touch electrically “hot” parts inside SP-135T.**
- **Have qualified personnel do the maintenance and trouble shooting work.**

ROUTINE MAINTENANCE

POWER SOURCE COMPARTMENT

No user serviceable parts inside! Do not attempt to perform service in the power source (fixed) side of the SP-135T. Take the unit to an authorized Lincoln Service Center if you experience problems. NO maintenance is required.

In extremely dusty locations, dirt may clog the air passages causing the welder to run hot with premature tripping of thermal protection. If so, blow dirt out of the welder with low pressure air at regular intervals to eliminate excessive dirt and dust build-up on internal parts.

WIRE FEED COMPARTMENT

1. When necessary, vacuum accumulated dirt from gearbox and wire feed section.
2. Occasionally inspect the incoming guide tube and clean inside diameter if necessary.
3. Motor and gearbox have lifetime lubrication and require no maintenance.

FAN MOTOR

Has lifetime lubrication — requires no maintenance.

WIRE REEL SPINDLE

Requires no maintenance. Do **not** lubricate shaft.

GUN AND CABLE MAINTENANCE

FOR MAGNUM™ 100L GUN

Gun Cable Cleaning

Clean cable liner after using approximately 300 lbs (136 kg) of solid wire or 50 lbs (23 kg) of flux-cored wire. Remove the cable from the wire feeder and lay it out straight on the floor. Remove the contact tip from the gun. Using low pressure air, gently blow out the cable liner from the gas diffuser end.

CAUTION

Excessive pressure at the start may cause the dirt to form a plug.

Flex the cable over its entire length and again blow out the cable. Repeat this procedure until no further dirt comes out.

Contact Tips, Nozzles, and Gun Tubes

1. Dirt can accumulate in the contact tip hole and restrict wire feeding. After each spool of wire is used, remove the contact tip and clean it by pushing a short piece of wire through the tip repeatedly. Use the wire as a reamer to remove dirt that may be adhering to the wall of the hole through the tip.

2. Replace worn contact tips as required. A variable or "hunting" arc is a typical symptom of a worn contact tip. To install a new tip, choose the correct size contact tip for the electrode being used (wire size is stenciled on the side of the contact tip) and screw it snugly into the gas diffuser.
3. Remove spatter from inside of gas nozzle and from tip after each 10 minutes of arc time or as required.
4. Be sure the gas nozzle is fully screwed onto the diffuser for gas shielded processes. For the Innershield® process, the gasless nozzle should be screws onto the diffuser.
5. To remove gun tube from gun, remove gas nozzle or gasless nozzle and remove diffuser from gun tube. Remove both collars from each end of the gun handle and separate the handle halves. Loosen the locking nut holding the gun tube in place against the gun end cable connector. Unscrew gun tube from cable connector. To install gun tube, screw the locking nut on the gun tube as far as possible. Then screw the gun tube into the cable connector until it bottoms. Then unscrew (no more than one turn) the gun tube until its axis is perpendicular to the flat sides of the cable connector and pointed in the direction of the trigger. Tighten the locking nut so as to maintain the proper relationship between the gun tube and the cable connector. Replace the gun handle, trigger and diffuser. Replace the gas nozzle or gasless nozzle.

CONFIGURATION OF COMPONENTS IN WIRE FEEDING SYSTEM

	Contact Tip	Cable Liner	Drive Roll
Components shipped with SP-135T•	KP2039-1B1 .025" (0.6mm)	KP1937-3 .030-.035" (0.8-0.9mm)	KP665-035 2 Smooth grooves Small .023-.025 (0.6mm) Large .030" -.035" (0.8mm)-(0.9mm)
K549-1 .035" (0.9mm) Innershield Welding Kit	KP2039-3B1 .035" (0.9mm)	KP1937-3 (.0.8-0.9mm)	Use Large groove of Drive Roll included with machine.
K664-2 .035 (0.9mm) Aluminum or Stainless Kit*	KP2078-1B1 .035A (0.9mm)	KP1959-1 .035" (0.9mm)	M19631

• If .030 Solid wire feeding is desired obtain an KP2039-2B1 Contact Tip.

* It is important when changing between welding with steel wire and aluminum to exchange feeding components due to the lubricant applied to steel wire. Failure to do so may result in contaminated welds when welding aluminum.

COMPONENT REPLACEMENT PROCEDURES

CHANGING THE CONTACT TIP

1. Refer to Figure D.2. Remove the gas nozzle from the gun by unscrewing counter-clockwise.
2. Remove the existing contact tip from the gun by unscrewing counter-clockwise.
3. Insert and hand tighten desired contact tip.
4. Replace gas nozzle.

CHANGING DRIVE ROLL

The drive roll has two grooves; one for .023" – .025" (0.6 mm) solid steel electrode and a larger knurled groove for .030" (0.8 mm) solid and .035" (0.9 mm) flux-cored steel electrode. As shipped, the drive roll is installed in the .030"/.035" (0.8/0.9 mm) position.

If .023" – .025" (0.6 mm) wire is to be used, the drive roll must be reversed as follows:

1. Connect the machine to its rated input power per instructions in Installation section.
2. Release the spring-loaded idle arm tensioner, Item 2, and lift the idle roll arm, Item 3, away from the drive roll, Item 1. (See Figure D.1)
3. Turn the power switch to ON (marked "I").
4. Set the wire speed to minimum and jog the drive unit with the trigger switch until the drive roll set screw is facing up.

CAUTION

When inching the welding wire, the drive rolls, gun connector block, and gun contact tip are energized relative to work and ground and remain energized for several seconds after the gun trigger is released.

5. Turn the power switch to OFF (marked "O").
6. Loosen the drive roll set screw with the 5/64" (2.0 mm) hex wrench supplied.
7. Remove the drive roll, flip over and reinstall with the .023 – .025" (0.6 mm) groove (the smaller groove) closest to the gearbox.

8. Push a length of straightened welding wire through the wire feeder guide tubes and adjust the position of the drive roll so that the groove is centered on the wire. Make certain the set screw is located on the flat portion of the shaft and tighten.

FIGURE D.1

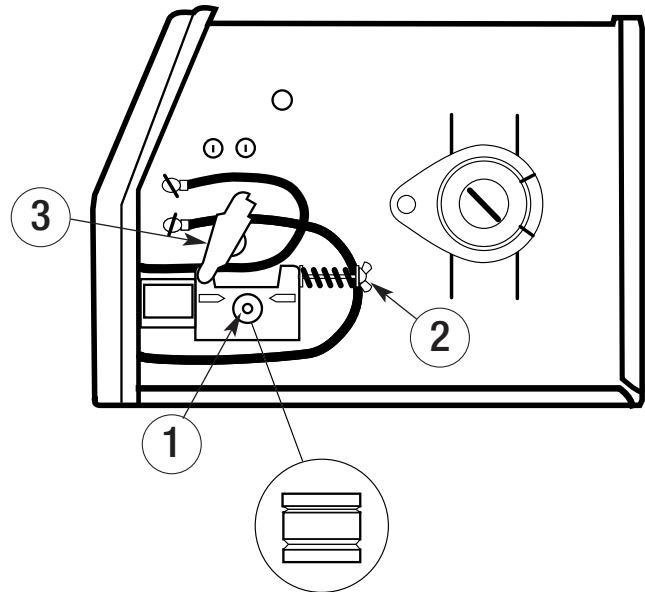

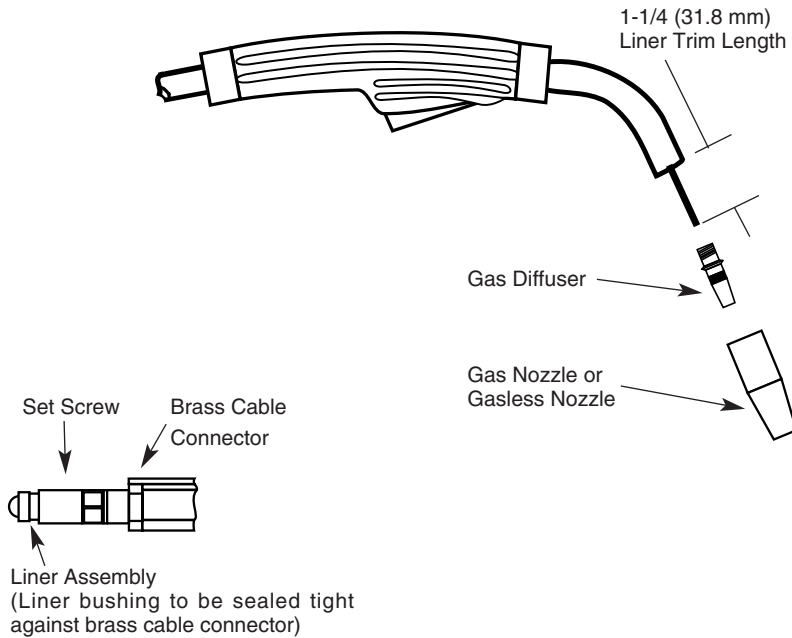

FIGURE D.2
Liner trim length

CHANGING LINER

NOTICE: The variation in cable lengths prevents the interchangeability of liners. Once a liner has been cut for a particular gun, it should not be installed in another gun unless it can meet the liner cutoff length requirement. Refer to Figure D.2.

1. Remove the gas nozzle from the gun by unscrewing counter-clockwise.
2. Remove the existing contact tip from the gun by unscrewing counter-clockwise.
3. Remove the gas diffuser from the gun tube by unscrewing counter-clockwise.
4. Lay the gun and cable out straight on a flat surface. Loosen the set screw located in the brass connector at the wire feeder end of the cable. Pull the liner out of the cable.
5. Insert a new untrimmed liner into the connector end of the cable. Be sure the liner bushing is stenciled appropriately for the wire size being used.
6. Fully seat the liner bushing into the connector. Tighten the set screw on the brass cable connector. At this time, the gas diffuser should not be installed onto the end of the gun tube.
7. With the gas nozzle and diffuser removed from the gun tube, be sure the cable is straight, and then trim the liner to the length shown in the Figure D.2. Remove any burrs from the end of the liner.

8. Screw the gas diffuser onto the end of the gun tube and securely tighten.

9. Replace the contact tip and nozzle.

GUN HANDLE PARTS

The gun handle consists of two halves that are held together with a collar on each end. To open up the handle, turn the collars approximately 60 degrees counter-clockwise until the collar reaches a stop. Then pull the collar off the gun handle. If the collars are difficult to turn, position the gun handle against a corner, place a screwdriver against the tab on the collar and give the screwdriver a sharp blow to turn the collar past an internal locking rib. See Figure D-3.

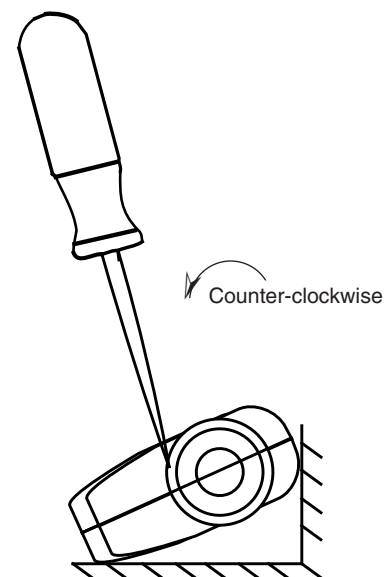

FIGURE D.3

HOW TO USE TROUBLESHOOTING GUIDE

WARNING

Service and Repair should only be performed by Lincoln Electric Factory Trained Personnel. Unauthorized repairs performed on this equipment may result in danger to the technician and machine operator and will invalidate your factory warranty. For your safety and to avoid Electrical Shock, please observe all safety notes and precautions detailed throughout this manual.

This Troubleshooting Guide is provided to help you locate and repair possible machine malfunctions. Simply follow the three-step procedure listed below.

Step 1. LOCATE PROBLEM (SYMPTOM).

Look under the column labeled “PROBLEM (SYMPTOMS)”. This column describes possible symptoms that the machine may exhibit. Find the listing that best describes the symptom that the machine is exhibiting.

Step 2. POSSIBLE CAUSE.

The second column labeled “POSSIBLE CAUSE” lists the obvious external possibilities that may contribute to the machine symptom.

Step 3. RECOMMENDED COURSE OF ACTION

This column provides a course of action for the Possible Cause, generally it states to contact your local Lincoln Authorized Field Service Facility.

If you do not understand or are unable to perform the Recommended Course of Action safely, contact your local Lincoln Authorized Field Service Facility.

CAUTION

If for any reason you do not understand the test procedures or are unable to perform the tests/repairs safely, contact your **Local Lincoln Authorized Field Service Facility** for technical troubleshooting assistance before you proceed.

Observe all Safety Guidelines detailed throughout this manual

PROBLEMS (SYMPTOMS)	POSSIBLE AREAS OF MISADJUSTMENT(S)	RECOMMENDED COURSE OF ACTION
OUTPUT PROBLEMS		
Major physical or electrical damage is evident.	None Contact your local Authorized Field Service Facility.	If all recommended possible areas of misadjustment have been checked and the problem persists, Contact your local Lincoln Authorized Field Service Facility.
No wire feed, weld output or gas flow when gun trigger is pulled. Fan does NOT operate.	<ol style="list-style-type: none"> 1. Make sure correct voltage is applied to the machine (115vac). 2. Make certain that power switch is in the ON position. 3. Make sure circuit breaker is reset. 	
No wire feed, weld output or gas flow when gun trigger is pulled Fan operates normally.	<ol style="list-style-type: none"> 1. The thermostat may be tripped due to overheating. Let machine cool. Weld at lower duty cycle. 2. Check for obstructions in air flow. Check Gun Trigger connections. See Installation section. 3. Gun trigger may be faulty. 	

 **CAUTION**

If for any reason you do not understand the test procedures or are unable to perform the tests/repairs safely, contact your **Local Lincoln Authorized Field Service Facility** for technical troubleshooting assistance before you proceed.

Observe all Safety Guidelines detailed throughout this manual

PROBLEMS (SYMPTOMS)	POSSIBLE AREAS OF MISADJUSTMENT(S)	RECOMMENDED COURSE OF ACTION
FEEDING PROBLEMS		
No wire feed when gun trigger is pulled. Fan runs, gas flows and machine has correct open circuit voltage (32VDC maximum) – weld output.	<ol style="list-style-type: none"> 1. If the wire drive motor is running make sure that the correct drive rolls are installed in the machine. 2. Check for clogged cable liner or contact tip. 3. Check for proper size cable liner and contact tip. 	If all recommended possible areas of misadjustment have been checked and the problem persists, Contact your local Lincoln Authorized Field Service Facility.

PROBLEMS (SYMPTOMS)	POSSIBLE AREAS OF MISADJUSTMENT(S)	RECOMMENDED COURSE OF ACTION
GAS FLOW PROBLEMS		
Low or no gas flow when gun trigger is pulled. Wire feed, weld output and fan operate normally.	<ol style="list-style-type: none"> 1. Check gas supply, flow regulator and gas hoses. 2. Check gun connection to machine for obstruction or leaky seals. 	If all recommended possible areas of misadjustment have been checked and the problem persists, Contact your local Lincoln Authorized Field Service Facility.

 **CAUTION**

If for any reason you do not understand the test procedures or are unable to perform the tests/repairs safely, contact your **Local Lincoln Authorized Field Service Facility** for technical troubleshooting assistance before you proceed.

Observe all Safety Guidelines detailed throughout this manual

PROBLEMS (SYMPTOMS)	POSSIBLE AREAS OF MISADJUSTMENT(S)	RECOMMENDED COURSE OF ACTION
WELDING PROBLEMS		
Arc is unstable – Poor starting	<ol style="list-style-type: none"> 1. Check for correct input voltage to machine – 115vac. 2. Check for proper electrode polarity for process. 3. Check gun tip for wear or damage and proper size – Replace. 4. Check for proper gas and flow rate for process. (For MIG only.) 5. Check work cable for loose or faulty connections. 6. Check gun for damage or breaks. 7. Check for proper drive roll orientation and alignment. 8. Check liner for proper size. 	<p>If all recommended possible areas of misadjustment have been checked and the problem persists, Contact your local Lincoln Authorized Field Service Facility.</p>

 **CAUTION**

If for any reason you do not understand the test procedures or are unable to perform the tests/repairs safely, contact your **Local Lincoln Authorized Field Service Facility** for technical troubleshooting assistance before you proceed.

WIRING DIAGRAM

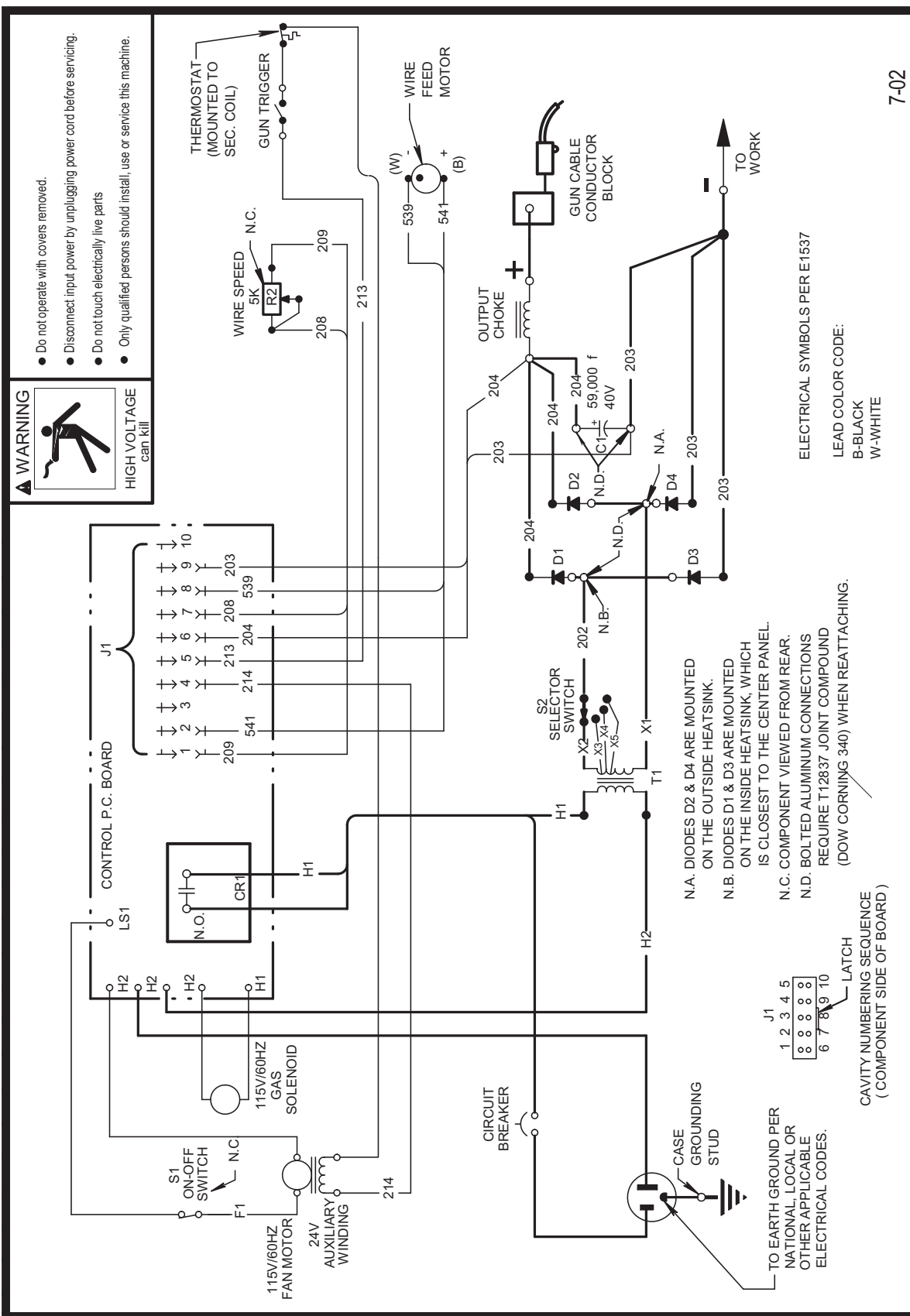

NOTE: This diagram is for reference only. It may not be accurate for all machines covered by this manual. The specific diagram for a particular code is pasted inside the machine on one of the enclosure panels.

NOTES

NOTES

			
WARNING	<ul style="list-style-type: none"> ● Do not touch electrically live parts or electrode with skin or wet clothing. ● Insulate yourself from work and ground. 	<ul style="list-style-type: none"> ● Keep flammable materials away. 	<ul style="list-style-type: none"> ● Wear eye, ear and body protection.
Spanish AVISO DE PRECAUCION	<ul style="list-style-type: none"> ● No toque las partes o los electrodos bajo carga con la piel o ropa mojada. ● Aislese del trabajo y de la tierra. 	<ul style="list-style-type: none"> ● Mantenga el material combustible fuera del área de trabajo. 	<ul style="list-style-type: none"> ● Protéjase los ojos, los oídos y el cuerpo.
French ATTENTION	<ul style="list-style-type: none"> ● Ne laissez ni la peau ni des vêtements mouillés entrer en contact avec des pièces sous tension. ● Isolez-vous du travail et de la terre. 	<ul style="list-style-type: none"> ● Gardez à l'écart de tout matériel inflammable. 	<ul style="list-style-type: none"> ● Protégez vos yeux, vos oreilles et votre corps.
German WARNUNG	<ul style="list-style-type: none"> ● Berühren Sie keine stromführenden Teile oder Elektroden mit Ihrem Körper oder feuchter Kleidung! ● Isolieren Sie sich von den Elektroden und dem Erdboden! 	<ul style="list-style-type: none"> ● Entfernen Sie brennbares Material! 	<ul style="list-style-type: none"> ● Tragen Sie Augen-, Ohren- und Körperschutz!
Portuguese ATENÇÃO	<ul style="list-style-type: none"> ● Não toque partes elétricas e electrodos com a pele ou roupa molhada. ● Isole-se da peça e terra. 	<ul style="list-style-type: none"> ● Mantenha inflamáveis bem guardados. 	<ul style="list-style-type: none"> ● Use proteção para a vista, ouvido e corpo.
Japanese 注意事項	<ul style="list-style-type: none"> ● 通電中の電気部品、又は溶材にヒフやぬれた布で触れないこと。 ● 施工物やアースから身体が絶縁されている様にして下さい。 	<ul style="list-style-type: none"> ● 燃えやすいものの側での溶接作業は絶対にしてはなりません。 	<ul style="list-style-type: none"> ● 目、耳及び身体に保護具をして下さい。
Chinese 警告	<ul style="list-style-type: none"> ● 皮肤或湿衣物切勿接触带电部件及焊条。 ● 使你自己与地面和工作件绝缘。 	<ul style="list-style-type: none"> ● 把一切易燃物品移离工作场所。 	<ul style="list-style-type: none"> ● 佩戴眼、耳及身体劳动保护用具。
Korean 위험	<ul style="list-style-type: none"> ● 전도체나 용접봉을 젖은 형갑 또는 피부로 절대 접촉치 마십시오. ● 모재와 접지를 접촉치 마십시오. 	<ul style="list-style-type: none"> ● 인화성 물질을 접근시키지 마십시오. 	<ul style="list-style-type: none"> ● 눈, 귀와 몸에 보호장구를 착용하십시오.
Arabic تحذير	<ul style="list-style-type: none"> ● لا تلمس الاجزاء التي يسري فيها التيار الكهربائي أو الألكترود بجسد الجسم أو بالملابس المبللة بالماء. ● ضع عازلا على جسمك خلال العمل. 	<ul style="list-style-type: none"> ● ضع المواد القابلة للاشتعال في مكان بعيد. 	<ul style="list-style-type: none"> ● ضع أدوات وملابس واقية على عينيك وأذنيك وجسمك.

READ AND UNDERSTAND THE MANUFACTURER'S INSTRUCTION FOR THIS EQUIPMENT AND THE CONSUMABLES TO BE USED AND FOLLOW YOUR EMPLOYER'S SAFETY PRACTICES.

SE RECOMIENDA LEER Y ENTENDER LAS INSTRUCCIONES DEL FABRICANTE PARA EL USO DE ESTE EQUIPO Y LOS CONSUMIBLES QUE VA A UTILIZAR, SIGA LAS MEDIDAS DE SEGURIDAD DE SU SUPERVISOR.

LISEZ ET COMPRENEZ LES INSTRUCTIONS DU FABRICANT EN CE QUI REGARDE CET EQUIPMENT ET LES PRODUITS A ETRE EMPLOYES ET SUIVEZ LES PROCEDURES DE SECURITE DE VOTRE EMPLOYEUR.

LESEN SIE UND BEFOLGEN SIE DIE BETRIEBSANLEITUNG DER ANLAGE UND DEN ELEKTRODENEINSATZ DES HERSTELLERS. DIE UNFALLVERHÜTUNGSVORSCHRIFTEN DES ARBEITGEBERS SIND EBENFALLS ZU BEACHTEN.

			
<ul style="list-style-type: none"> ● Keep your head out of fumes. ● Use ventilation or exhaust to remove fumes from breathing zone. 	<ul style="list-style-type: none"> ● Turn power off before servicing. 	<ul style="list-style-type: none"> ● Do not operate with panel open or guards off. 	WARNING
<ul style="list-style-type: none"> ● Los humos fuera de la zona de respiración. ● Mantenga la cabeza fuera de los humos. Utilice ventilación o aspiración para gases. 	<ul style="list-style-type: none"> ● Desconectar el cable de alimentación de poder de la máquina antes de iniciar cualquier servicio. 	<ul style="list-style-type: none"> ● No operar con panel abierto o guardas quitadas. 	Spanish AVISO DE PRECAUCION
<ul style="list-style-type: none"> ● Gardez la tête à l'écart des fumées. ● Utilisez un ventilateur ou un aspirateur pour ôter les fumées des zones de travail. 	<ul style="list-style-type: none"> ● Débranchez le courant avant l'entretien. 	<ul style="list-style-type: none"> ● N'opérez pas avec les panneaux ouverts ou avec les dispositifs de protection enlevés. 	French ATTENTION
<ul style="list-style-type: none"> ● Vermeiden Sie das Einatmen von Schweißrauch! ● Sorgen Sie für gute Be- und Entlüftung des Arbeitsplatzes! 	<ul style="list-style-type: none"> ● Strom vor Wartungsarbeiten abschalten! (Netzstrom völlig öffnen; Maschine anhalten!) 	<ul style="list-style-type: none"> ● Anlage nie ohne Schutzgehäuse oder Innenschutzverkleidung in Betrieb setzen! 	German WARNUNG
<ul style="list-style-type: none"> ● Mantenha seu rosto da fumaça. ● Use ventilação e exaustão para remover fumo da zona respiratória. 	<ul style="list-style-type: none"> ● Não opere com as tampas removidas. ● Desligue a corrente antes de fazer serviço. ● Não toque as partes elétricas nuas. 	<ul style="list-style-type: none"> ● Mantenha-se afastado das partes moventes. ● Não opere com os painéis abertos ou guardas removidas. 	Portuguese ATENÇÃO
<ul style="list-style-type: none"> ● ヒュームから頭を離すようにして下さい。 ● 換気や排煙に十分留意して下さい。 	<ul style="list-style-type: none"> ● メンテナンス・サービスに取りかかる際には、まず電源スイッチを必ず切ってください。 	<ul style="list-style-type: none"> ● パネルやカバーを取り外したまま機械操作をしないで下さい。 	Japanese 注意事項
<ul style="list-style-type: none"> ● 頭部遠離煙霧。 ● 在呼吸區使用通風或排風器除煙。 	<ul style="list-style-type: none"> ● 維修前切斷電源。 	<ul style="list-style-type: none"> ● 儀表板打開或沒有安全罩時不準作業。 	Chinese 警告
<ul style="list-style-type: none"> ● 얼굴로부터 용접가스를 멀리하십시오. ● 호흡지역으로부터 용접가스를 제거하기 위해 가스제거기나 통풍기를 사용하십시오. 	<ul style="list-style-type: none"> ● 보수전에 전원을 차단하십시오. 	<ul style="list-style-type: none"> ● 판넬이 열린 상태로 작동치 마십시오. 	Korean 위험
<ul style="list-style-type: none"> ● ابعد رأسك بعيداً عن الدخان. ● استعمل التهوية أو جهاز ضغط الدخان للخارج لكي تبعد الدخان عن المنطقة التي تتنفس فيها. 	<ul style="list-style-type: none"> ● أقطع التيار الكهربائي قبل القيام بأية صيانة. 	<ul style="list-style-type: none"> ● لا تشغيل هذا الجهاز اذا كانت الاغطية الحديدية الواقية ليست عليه. 	Arabic تحذير

LEIA E COMPREENDA AS INSTRUÇÕES DO FABRICANTE PARA ESTE EQUIPAMENTO E AS PARTES DE USO, E SIGA AS PRÁTICAS DE SEGURANÇA DO EMPREGADOR.

使う機械や溶材のメーカーの指示書をよく読み、まず理解して下さい。そして貴社の安全規定に従って下さい。

請詳細閱讀並理解製造廠提供的說明以及應該使用的銀焊材料，並請遵守貴方的有閣勞動保護規定。

이 제품에 동봉된 작업지침서를 숙지하시고 귀사의 작업자 안전수칙을 준수하시기 바랍니다.

اقرأ بتمعن وافهم تعليمات المصنع المنتج لهذه المعدات والمواد قبل استعمالها واتبع تعليمات الوقاية لصاحب العمل.



• World's Leader in Welding and Cutting Products •

• Sales and Service through Subsidiaries and Distributors Worldwide •

Cleveland, Ohio 44117-1199 U.S.A. TEL: 216.481.8100 FAX: 216.486.1751 WEB SITE: www.lincolnelectric.com