

# Operator's Manual

# **APEX<sup>®</sup> 30S CONTROL**

**ORIGINAL INSTRUCTIONS**

For use with machines having Code Numbers:

12835, 13215, 13410,  
13653, 13703, 13704

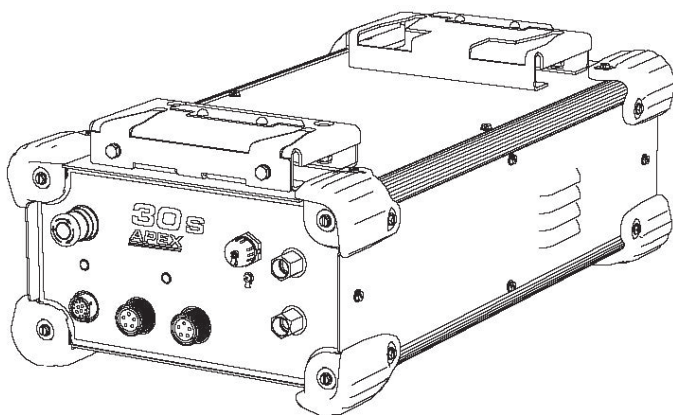

Register your machine:  
[www.lincolnelectric.com/register](http://www.lincolnelectric.com/register)  
Authorized Service and Distributor Locator:  
[www.lincolnelectric.com/locator](http://www.lincolnelectric.com/locator)

Save for future reference

Date Purchased

Code: (ex: 12675)

Serial: (ex: U1060512345)

Need Help? In the USA and Canada, call  
1.800.770.0063 to talk to a Service Representative.

Hours of Operation:  
7:00 AM to 5:00 PM (PT) Mon. thru Fri.

After hours?  
Use "Ask the Experts" at [lincolnelectric.com](http://lincolnelectric.com)  
A Lincoln Service Representative will contact you  
no later than the following business day.

For Service outside the USA and Canada, please call  
1.619.628.1022 or e-mail us at:  
[orbitalsupport@lincolnelectric.com](mailto:orbitalsupport@lincolnelectric.com)

## **THE LINCOLN ELECTRIC COMPANY**

22801 St. Clair Avenue • Cleveland, OH • 44117-1199 • U.S.A.  
Phone: +1.216.481.8100 • [www.lincolnelectric.com](http://www.lincolnelectric.com)

## **LINCOLN ELECTRIC EUROPE S.L.**

c/o Balmes, 89 - 8<sup>o</sup> 2<sup>a</sup>  
08008 Barcelona  
SPAIN

# THANK YOU FOR SELECTING A QUALITY PRODUCT BY LINCOLN ELECTRIC.

## PLEASE EXAMINE CARTON AND EQUIPMENT FOR DAMAGE IMMEDIATELY

When this equipment is shipped, title passes to the purchaser upon receipt by the carrier. Consequently, claims for material damaged in shipment must be made by the purchaser against the transportation company at the time the shipment is received.

## SAFETY DEPENDS ON YOU

Lincoln arc welding and cutting equipment is designed and built with safety in mind. However, your overall safety can be increased by proper installation ... and thoughtful operation on your part. **DO NOT INSTALL, OPERATE OR REPAIR THIS EQUIPMENT WITHOUT READING THIS MANUAL AND THE SAFETY PRECAUTIONS CONTAINED THROUGHOUT.** And, most importantly, think before you act and be careful.

### **WARNING**

This statement appears where the information must be followed exactly to avoid serious personal injury or loss of life.

### **CAUTION**

This statement appears where the information must be followed to avoid minor personal injury or damage to this equipment.



## KEEP YOUR HEAD OUT OF THE FUMES.

**DON'T** get too close to the arc. Use corrective lenses if necessary to stay a reasonable distance away from the arc.

**READ** and obey the Safety Data Sheet (SDS) and the warning label that appears on all containers of welding materials.

**USE ENOUGH VENTILATION** or exhaust at the arc, or both, to keep the fumes and gases from your breathing zone and the general area.

**IN A LARGE ROOM OR OUTDOORS**, natural ventilation may be adequate if you keep your head out of the fumes (See below).

**USE NATURAL DRAFTS** or fans to keep the fumes away from your face.

If you develop unusual symptoms, see your supervisor. Perhaps the welding atmosphere and ventilation system should be checked.

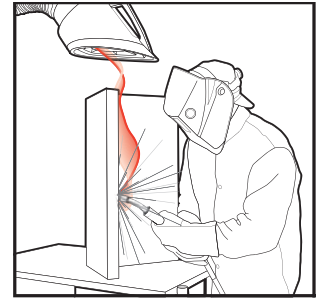

## WEAR CORRECT EYE, EAR & BODY PROTECTION

**PROTECT** your eyes and face with welding helmet properly fitted and with proper grade of filter plate (See ANSI Z49.1).

**PROTECT** your body from welding spatter and arc flash with protective clothing including woolen clothing, flame-proof apron and gloves, leather leggings, and high boots.

**PROTECT** others from splatter, flash, and glare with protective screens or barriers.

**IN SOME AREAS**, protection from noise may be appropriate.

**BE SURE** protective equipment is in good condition.

Also, wear safety glasses in work area **AT ALL TIMES.**



## SPECIAL SITUATIONS

**DO NOT WELD OR CUT** containers or materials which previously had been in contact with hazardous substances unless they are properly cleaned. This is extremely dangerous.

**DO NOT WELD OR CUT** painted or plated parts unless special precautions with ventilation have been taken. They can release highly toxic fumes or gases.

## Additional precautionary measures

**PROTECT** compressed gas cylinders from excessive heat, mechanical shocks, and arcs; fasten cylinders so they cannot fall.

**BE SURE** cylinders are never grounded or part of an electrical circuit.

**REMOVE** all potential fire hazards from welding area.

**ALWAYS HAVE FIRE FIGHTING EQUIPMENT READY FOR IMMEDIATE USE AND KNOW HOW TO USE IT.**



## SECTION A: WARNINGS



### CALIFORNIA PROPOSITION 65 WARNINGS



**WARNING:** Breathing diesel engine exhaust exposes you to chemicals known to the State of California to cause cancer and birth defects, or other reproductive harm.

- Always start and operate the engine in a well-ventilated area.
- If in an exposed area, vent the exhaust to the outside.
- Do not modify or tamper with the exhaust system.
- Do not idle the engine except as necessary.

For more information go to [www.P65warnings.ca.gov/diesel](http://www.P65warnings.ca.gov/diesel)

**WARNING:** This product, when used for welding or cutting, produces fumes or gases which contain chemicals known to the State of California to cause birth defects and, in some cases, cancer. (California Health & Safety Code § 25249.5 *et seq.*)



**WARNING:** Cancer and Reproductive Harm  
[www.P65warnings.ca.gov](http://www.P65warnings.ca.gov)

**ARC WELDING CAN BE HAZARDOUS. PROTECT YOURSELF AND OTHERS FROM POSSIBLE SERIOUS INJURY OR DEATH. KEEP CHILDREN AWAY. PACEMAKER WEARERS SHOULD CONSULT WITH THEIR DOCTOR BEFORE OPERATING.**

Read and understand the following safety highlights. For additional safety information, it is strongly recommended that you purchase a copy of "Safety in Welding & Cutting - ANSI Standard Z49.1" from the American Welding Society, P.O. Box 351040, Miami, Florida 33135 or CSA Standard W117.2. A Free copy of "Arc Welding Safety" booklet E205 is available from the Lincoln Electric Company, 22801 St. Clair Avenue, Cleveland, Ohio 44117-1199.

**BE SURE THAT ALL INSTALLATION, OPERATION, MAINTENANCE AND REPAIR PROCEDURES ARE PERFORMED ONLY BY QUALIFIED INDIVIDUALS.**



### FOR ENGINE POWERED EQUIPMENT.

- Turn the engine off before troubleshooting and maintenance work unless the maintenance work requires it to be running.
- Operate engines in open, well-ventilated areas or vent the engine exhaust fumes outdoors.
- Do not add the fuel near an open flame welding arc or when the engine is running. Stop the engine and allow it to cool before refueling to prevent spilled fuel from vaporizing on contact



with hot engine parts and igniting. Do not spill fuel when filling tank. If fuel is spilled, wipe it up and do not start engine until fumes have been eliminated.

- Keep all equipment safety guards, covers and devices in position and in good repair. Keep hands, hair, clothing and tools away from V-belts, gears, fans and all other moving parts when starting, operating or repairing equipment.
- In some cases it may be necessary to remove safety guards to perform required maintenance. Remove guards only when necessary and replace them when the maintenance requiring their removal is complete. Always use the greatest care when working near moving parts.
- Do not put your hands near the engine fan. Do not attempt to override the governor or idler by pushing on the throttle control rods while the engine is running.
- To prevent accidentally starting gasoline engines while turning the engine or welding generator during maintenance work, disconnect the spark plug wires, distributor cap or magneto wire as appropriate.
- To avoid scalding, do not remove the radiator pressure cap when the engine is hot.
- Using a generator indoors CAN KILL YOU IN MINUTES.
- Generator exhaust contains carbon monoxide. This is a poison you cannot see or smell.
- NEVER use inside a home or garage, EVEN IF doors and windows are open.
- Only use OUTSIDE and far away from windows, doors and vents.
- Avoid other generator hazards. READ MANUAL BEFORE USE.



### ELECTRIC AND MAGNETIC FIELDS MAY BE DANGEROUS



- Electric current flowing through any conductor causes localized Electric and Magnetic Fields (EMF). Welding current creates EMF fields around welding cables and welding machines
- EMF fields may interfere with some pacemakers, and welders having a pacemaker should consult their physician before welding.
- Exposure to EMF fields in welding may have other health effects which are now not known.
- All welders should use the following procedures in order to minimize exposure to EMF fields from the welding circuit:
  - Route the electrode and work cables together - Secure them with tape when possible.
  - Never coil the electrode lead around your body.
  - Do not place your body between the electrode and work cables. If the electrode cable is on your right side, the work cable should also be on your right side.
  - Connect the work cable to the workpiece as close as possible to the area being welded.
  - Do not work next to welding power source.



## ELECTRIC SHOCK CAN KILL.



- 3.a. The electrode and work (or ground) circuits are electrically “hot” when the welder is on. Do not touch these “hot” parts with your bare skin or wet clothing. Wear dry, hole-free gloves to insulate hands.
- 3.b. Insulate yourself from work and ground using dry insulation. Make certain the insulation is large enough to cover your full area of physical contact with work and ground.

**In addition to the normal safety precautions, if welding must be performed under electrically hazardous conditions (in damp locations or while wearing wet clothing; on metal structures such as floors, gratings or scaffolds; when in cramped positions such as sitting, kneeling or lying, if there is a high risk of unavoidable or accidental contact with the workpiece or ground) use the following equipment:**

- Semiautomatic DC Constant Voltage (Wire) Welder.
  - DC Manual (Stick) Welder.
  - AC Welder with Reduced Voltage Control.
- 3.c. In semiautomatic or automatic wire welding, the electrode, electrode reel, welding head, nozzle or semiautomatic welding gun are also electrically “hot”.
  - 3.d. Always be sure the work cable makes a good electrical connection with the metal being welded. The connection should be as close as possible to the area being welded.
  - 3.e. Ground the work or metal to be welded to a good electrical (earth) ground.
  - 3.f. Maintain the electrode holder, work clamp, welding cable and welding machine in good, safe operating condition. Replace damaged insulation.
  - 3.g. Never dip the electrode in water for cooling.
  - 3.h. Never simultaneously touch electrically “hot” parts of electrode holders connected to two welders because voltage between the two can be the total of the open circuit voltage of both welders.
  - 3.i. When working above floor level, use a safety belt to protect yourself from a fall should you get a shock.
  - 3.j. Also see Items 6.c. and 8.



## ARC RAYS CAN BURN.



- 4.a. Use a shield with the proper filter and cover plates to protect your eyes from sparks and the rays of the arc when welding or observing open arc welding. Headshield and filter lens should conform to ANSI Z87.1 standards.
- 4.b. Use suitable clothing made from durable flame-resistant material to protect your skin and that of your helpers from the arc rays.
- 4.c. Protect other nearby personnel with suitable, non-flammable screening and/or warn them not to watch the arc nor expose themselves to the arc rays or to hot spatter or metal.



## FUMES AND GASES CAN BE DANGEROUS.



- 5.a. Welding may produce fumes and gases hazardous to health. Avoid breathing these fumes and gases. When welding, keep your head out of the fume. Use enough ventilation and/or exhaust at the arc to keep fumes and gases away from the breathing zone. **When welding hardfacing (see instructions on container or SDS) or on lead or cadmium plated steel and other metals or coatings which produce highly toxic fumes, keep exposure as low as possible and within applicable OSHA PEL and ACGIH TLV limits using local exhaust or mechanical ventilation unless exposure assessments indicate otherwise. In confined spaces or in some circumstances, outdoors, a respirator may also be required. Additional precautions are also required when welding on galvanized steel.**
- 5.b. The operation of welding fume control equipment is affected by various factors including proper use and positioning of the equipment, maintenance of the equipment and the specific welding procedure and application involved. Worker exposure level should be checked upon installation and periodically thereafter to be certain it is within applicable OSHA PEL and ACGIH TLV limits.
- 5.c. Do not weld in locations near chlorinated hydrocarbon vapors coming from degreasing, cleaning or spraying operations. The heat and rays of the arc can react with solvent vapors to form phosgene, a highly toxic gas, and other irritating products.
- 5.d. Shielding gases used for arc welding can displace air and cause injury or death. Always use enough ventilation, especially in confined areas, to insure breathing air is safe.
- 5.e. Read and understand the manufacturer’s instructions for this equipment and the consumables to be used, including the Safety Data Sheet (SDS) and follow your employer’s safety practices. SDS forms are available from your welding distributor or from the manufacturer.
- 5.f. Also see item 1.b.





## WELDING AND CUTTING SPARKS CAN CAUSE FIRE OR EXPLOSION.

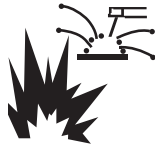

- 6.a. Remove fire hazards from the welding area. If this is not possible, cover them to prevent the welding sparks from starting a fire. Remember that welding sparks and hot materials from welding can easily go through small cracks and openings to adjacent areas. Avoid welding near hydraulic lines. Have a fire extinguisher readily available.
- 6.b. Where compressed gases are to be used at the job site, special precautions should be used to prevent hazardous situations. Refer to "Safety in Welding and Cutting" (ANSI Standard Z49.1) and the operating information for the equipment being used.
- 6.c. When not welding, make certain no part of the electrode circuit is touching the work or ground. Accidental contact can cause overheating and create a fire hazard.
- 6.d. Do not heat, cut or weld tanks, drums or containers until the proper steps have been taken to insure that such procedures will not cause flammable or toxic vapors from substances inside. They can cause an explosion even though they have been "cleaned". For information, purchase "Recommended Safe Practices for the Preparation for Welding and Cutting of Containers and Piping That Have Held Hazardous Substances", AWS F4.1 from the American Welding Society (see address above).
- 6.e. Vent hollow castings or containers before heating, cutting or welding. They may explode.
- 6.f. Sparks and spatter are thrown from the welding arc. Wear oil free protective garments such as leather gloves, heavy shirt, cuffless trousers, high shoes and a cap over your hair. Wear ear plugs when welding out of position or in confined places. Always wear safety glasses with side shields when in a welding area.
- 6.g. Connect the work cable to the work as close to the welding area as practical. Work cables connected to the building framework or other locations away from the welding area increase the possibility of the welding current passing through lifting chains, crane cables or other alternate circuits. This can create fire hazards or overheat lifting chains or cables until they fail.
- 6.h. Also see item 1.c.
- 6.i. Read and follow NFPA 51B "Standard for Fire Prevention During Welding, Cutting and Other Hot Work", available from NFPA, 1 Batterymarch Park, PO box 9101, Quincy, MA 022690-9101.
- 6.j. Do not use a welding power source for pipe thawing.



## CYLINDER MAY EXPLODE IF DAMAGED.

- 7.a. Use only compressed gas cylinders containing the correct shielding gas for the process used and properly operating regulators designed for the gas and pressure used. All hoses, fittings, etc. should be suitable for the application and maintained in good condition. 
- 7.b. Always keep cylinders in an upright position securely chained to an undercarriage or fixed support.
- 7.c. Cylinders should be located:
  - Away from areas where they may be struck or subjected to physical damage.
  - A safe distance from arc welding or cutting operations and any other source of heat, sparks, or flame.
- 7.d. Never allow the electrode, electrode holder or any other electrically "hot" parts to touch a cylinder.
- 7.e. Keep your head and face away from the cylinder valve outlet when opening the cylinder valve.
- 7.f. Valve protection caps should always be in place and hand tight except when the cylinder is in use or connected for use.
- 7.g. Read and follow the instructions on compressed gas cylinders, associated equipment, and CGA publication P-1, "Precautions for Safe Handling of Compressed Gases in Cylinders," available from the Compressed Gas Association, 14501 George Carter Way Chantilly, VA 20151.



## FOR ELECTRICALLY POWERED EQUIPMENT.



- 8.a. Turn off input power using the disconnect switch at the fuse box before working on the equipment.
- 8.b. Install equipment in accordance with the U.S. National Electrical Code, all local codes and the manufacturer's recommendations.
- 8.c. Ground the equipment in accordance with the U.S. National Electrical Code and the manufacturer's recommendations.

**Refer to**  
<http://www.lincolnelectric.com/safety>  
**for additional safety information.**

# ELECTROMAGNETIC COMPATIBILITY (EMC)

## CONFORMANCE

Products displaying the CE mark are in conformity with European Community Council Directive of 3 May 1989 on the approximation of the laws of the Member States relating to electromagnetic compatibility (2014/30/UE). It was manufactured in conformity with a national standard that implements a harmonized standard: EN 60974-10

Electromagnetic Compatibility (EMC) Product Standard for Arc Welding Equipment. It is for use with other Lincoln Electric equipment. It is designed for industrial and professional use.

## INTRODUCTION

All electrical equipment generates small amounts of electromagnetic emission. Electrical emission may be transmitted through power lines or radiated through space, similar to a radio transmitter. When emissions are received by other equipment, electrical interference may result. Electrical emissions may affect many kinds of electrical equipment; other nearby welding equipment, radio and TV reception, numerical controlled machines, telephone systems, computers, etc. Be aware that interference may result and extra precautions may be required when a welding power source is used in a domestic establishment.

## INSTALLATION AND USE

The user is responsible for installing and using the welding equipment according to the manufacturer's instructions. If electromagnetic disturbances are detected then it shall be the responsibility of the user of the welding equipment to resolve the situation with the technical assistance of the manufacturer. In some cases this remedial action may be as simple as earthing (grounding) the welding circuit, see Note. In other cases it could involve construction of an electromagnetic screen enclosing the power source and the work complete with associated input filters. In all cases electromagnetic disturbances must be reduced to the point where they are no longer troublesome.

Note: The welding circuit may or may not be earthed for safety reasons according to national codes. Changing the earthing arrangements should only be authorized by a person who is competent to assess whether the changes will increase the risk of injury, e.g., by allowing parallel welding current return paths which may damage the earth circuits of other equipment.

## ASSESSMENT OF AREA

Before installing welding equipment, the user shall make an assessment of potential electromagnetic problems in the surrounding area. The following shall be taken into account:

- a. Other supply cables, control cables, signaling and telephone cables; above, below and adjacent to the welding equipment;
- b. radio and television transmitters and receivers;
- c. computer and other control equipment;
- d. safety critical equipment, e.g., guarding of industrial equipment;
- e. the health of the people around, e.g., the use of pacemakers and hearing aids;
- f. equipment used for calibration or measurement and
- g. the immunity of other equipment in the environment. The user shall ensure that other equipment being used in the environment is compatible. This may require additional protection measures including:
- h. the time of day that welding or other activities are to be carried out.

The size of the surrounding area to be considered will depend on the structure of the building and other activities that are taking place. The surrounding area may extend beyond the boundaries of the premises.

## METHODS OF REDUCING EMISSIONS

### Mains Supply

Welding equipment should be connected to the mains supply according to the manufacturer's recommendations. If interference occurs, it may be necessary to take additional precautions such as filtering of the mains supply. Consideration should be given to shielding the supply cable of permanently installed welding equipment, in metallic conduit or equivalent. Shielding should be electrically continuous throughout its length. The shielding should be connected to the welding power source so that good electrical contact is maintained between the conduit and the welding power source enclosure.

### Maintenance of the Welding Equipment

The welding equipment should be routinely maintained according to the manufacturer's recommendations. All access and service doors and covers should be closed and properly fastened when the welding equipment is in operation. The welding equipment should not be modified in any way except for those changes and adjustments covered in the manufacturer's instructions. In particular, the spark gaps of arc striking and stabilizing devices should be adjusted and maintained according to the manufacturer's recommendations.

### Welding Cables

The welding cables should be kept as short as possible and should be positioned close together, running at or close to floor level.

### Equipotential Bonding

Bonding of all metallic components in the welding installation and adjacent to it should be considered. However, metallic components bonded to the work piece will increase the risk that the operator could receive a shock by touching these metallic components and the electrode at the same time. The operator should be insulated from all such bonded metallic components.

### Earthing of the Workpiece

Where the workpiece is not bonded to earth for electrical safety, not connected to earth because of its size and position, e.g., ships hull or building steelwork, a connection bonding the workpiece to earth may reduce emissions in some, but not all instances. Care should be taken to prevent the earthing of the work piece increasing the risk of injury to users, or damage to other electrical equipment. Where necessary, the connection of the workpiece to earth should be made by a direct connection to the work piece, but in some countries where direct connection is not permitted, the bonding should be achieved by suitable capacitance, selected according to national regulations.

### Screening and Shielding

Selective screening and shielding of other cables and equipment in the surrounding area may alleviate problems of interference. Screening of the entire welding installation may be considered for special applications.

- 1 Portions of the preceding text are contained in EN 60974-10: "Electromagnetic Compatibility (EMC) product standard for arc welding equipment."

---

<b>Technical Specifications APEX 30S</b> .....	<b>A-1</b>
<b>Safety Precautions</b> .....	<b>A-2</b>
Proper Handling .....	A-2
Operation .....	A-2
<b>APEX 30S System</b> .....	<b>B-1</b>
Basic Information .....	B-1
Front Panel.....	B-1
Back Panel Connections.....	B-2
Installation.....	B-2
System Cart .....	B-2
Optional Modules.....	B-2
Power Source.....	B-3
Inverter Cart Top Bracket .....	B-3
Lift Cart Top Bracket .....	B-3
Cable Installation .....	B-4
Cable List .....	B-4
Inverter and Lift Cart Cable Installation .....	B-5
Shielding Gas Connection .....	B-6
<b>Maintenance</b> .....	<b>D-1</b>
Maintenance Schedule.....	D-1
Every Shift.....	D-1
Monthly .....	D-1
Using the Status LED to Troubleshoot System Problems.....	F-1
Weld Head Status LED Error Codes .....	F-2
<b>Diagrams</b> .....	<b>G-1</b>
<b>APEX 30S PARTS MANUAL</b> .....	<b>P-1</b>

# Technical Specifications APEX® 30S

APEX 30S Control Unit Product Number K52217-1	
<b>Input Power</b>	40 VDC
<b>Rated Output</b>	24V 9A
<b>Input Current</b>	10A Max
<b>Dimensions L x W x H (in.)</b>	25.33 x 11 x 14.33
<b>Dimensions L x W x H (mm)</b>	644.4 x 279.4 x 363.2
<b>Net Weight lbs. (kg)</b>	36.1 (16.4)
<b>Temperature Ranges</b>	
Operating Temperature Range 32°F to 122°F (0°C - 50°C)	Storage Temperature Range -22°F to 140°F (-30°C - 60°C)
A-weighted emission sound pressure level: less than 70 db (A)	

## Safety Precautions

Read entire manual before installation or operation.



### WARNING

#### ELECTRIC SHOCK CAN KILL



- Only qualified personnel should perform this installation.
- Turn the input power OFF at the disconnect switch or fuse box before working on this equipment turn off the input power to any other equipment connected to the welding system at the disconnect switch or fuse box before working on the equipment.
- Do not touch electrically hot parts.
- Always connect the power supply grounding lug to a proper safety (Earth) ground.

## Proper Handling

Do not attempt to pick up, move or manipulate the control unit by the cables.

Always operate the control unit on stable, flat and level surfaces with the bottom or side rails facing the ground. Be sure to leave adequate room to open the door to the wire feed assembly. Unplug the control unit when not in use. Do not place on wet ground or in puddles.

The system cart is designed for flat even surfaces. Do no overload cart.

## Operation

Read entire manual before operation.

Only operate while on firm level surface or attached to a system cart. Always verify that the system cart is secured in place before operation.

Keep hands away from weld head while in operation.



### CAUTION

Never unplug or plug in control cables to the tractor while the system is powered on.

Verify that the system is properly grounded before beginning to weld.

Refer to the individual system manuals for additional instructions.



# APEX 30S System

## Basic Information

The APEX 30S Control Unit (K52217-1) is part of the APEX 3 Series family of controllers and is the first of its kind that can be used for GMAW/FCAW and GTAW welding.

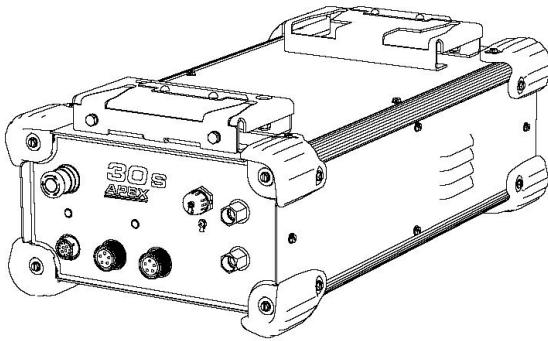

FIGURE 1 - APEX 30S

Moving from flat track, plate or other structural beams to an orbital track takes only a simple weld head adjustment. Synchronizing amps, volts, travel speed, and oscillation, the APEX 30S controller can be utilized for more welding applications than before.

The APEX 30S controller also reduces the need for auxiliary components by incorporating a gas solenoid and flow sensor within the controller, minimizing cable clutter and reducing the overall footprint of the configured system.

The status of APEX 30S controller can be monitored on the front panel – see **FIGURE 2 - Front Panel**. Additionally, the front of the control has a halt button, two connections for pendants, a weld head connector, and a USB port.

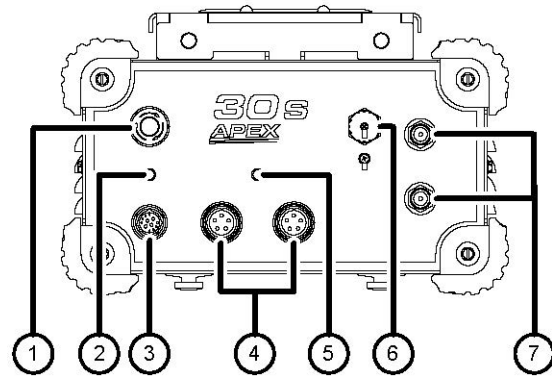

FIGURE 2 - Front Panel

### Front Panel

For all front panel connections – see **FIGURE 2 - Front Panel**.

1. **Halt Switch** - Removes power from the weld head, pendant and any ArcLink® device connected to the front of the 30S controller. The system will remain off until the switch is rotated clockwise. This switch does not shut off the power source.
2. **Motion Network Status** - The network status light will show green if all motion systems are operational.
3. **Weld Head Connector** - Connection from the APEX 30M to the weld head.
4. **ArcLink Out** - Two ArcLink cable connections for pendants or other ArcLink devices.
5. **ArcLink Status** - The ArcLink status light will be green if all ArcLink systems are operational.
6. **USB** - Welding programs and data can be saved and loaded via USB.
7. **Gas Outputs** - Two connections for gas flow that have independent solenoid valves and flow sensors.

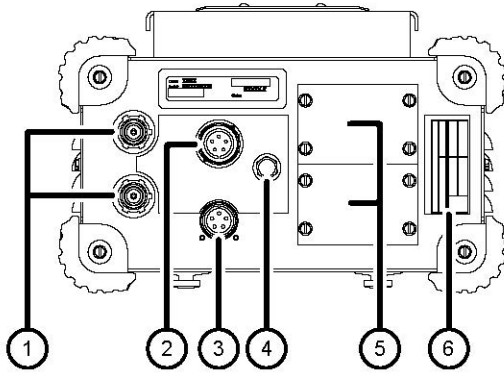

Figure 3 - Back Panel

### Back Panel Connections

For all bank panel connections – see **FIGURE 4 - Back Panel**.

1. **Gas Inputs** - Welding gas supplied to the system.
2. **ArcLink In** - The ArcLink connection from the power source or other ArcLink enabled device
3. **ArcLink Out** - ArcLink connection for auxilliary device.
4. **Breaker 10A** - Will trip in overpower situations; push to re-engage.
5. **Upgrade Panels** - Two panels where upgrade kits can be installed, such as the ArcLink Bridge Kit for enabling Hot Wire TIG.
6. **Rating Plate** - Contains technical information for the machine.

### Installation

On a standard APEX 30S Control, the components are designed to be installed on the system cart in a specific order.

### System Cart

The system cart comes fully assembled when ordered as a part of a complete system. If ordered separately, it may require additional assembly. Please refer to system cart assembly instructions for complete step-by-step instructions.

### Optional Modules

The optional modules are installed in both system carts before the power source – see **FIGURE 4 - Inverter Cart System Assembly** and **FIGURE 5** (on page B-3) - **Lift Cart System Assembly**. Set the module into the mounting holes provided and push backwards to seat the module.

Install the bracket to lock the module in place.

Optional modules have brackets in the top to support the power source.

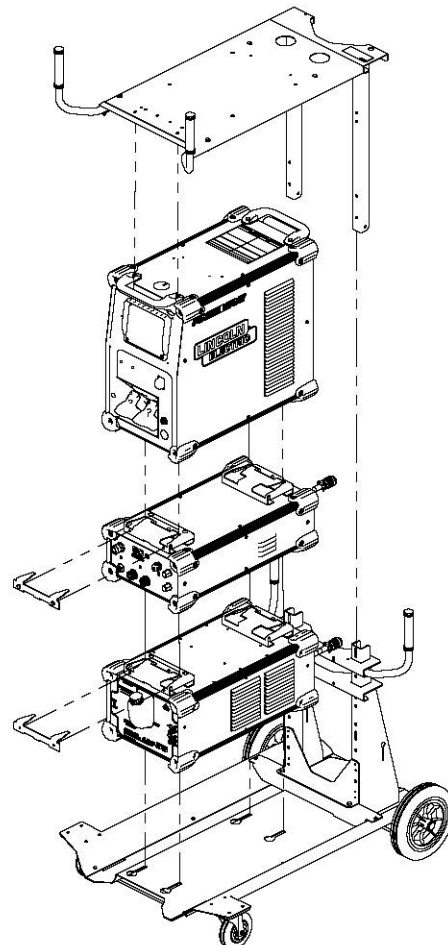

FIGURE 4 - Inverter Cart System Assembly

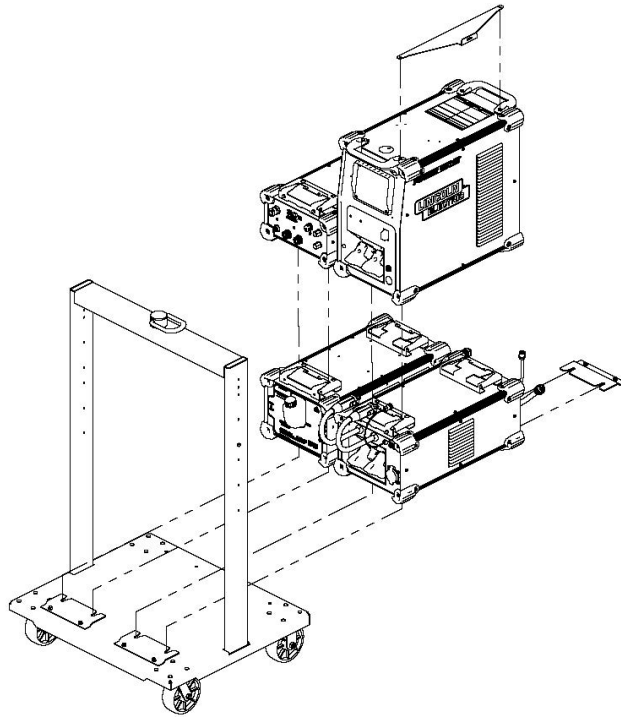

FIGURE 5 - Lift Cart System Assembly

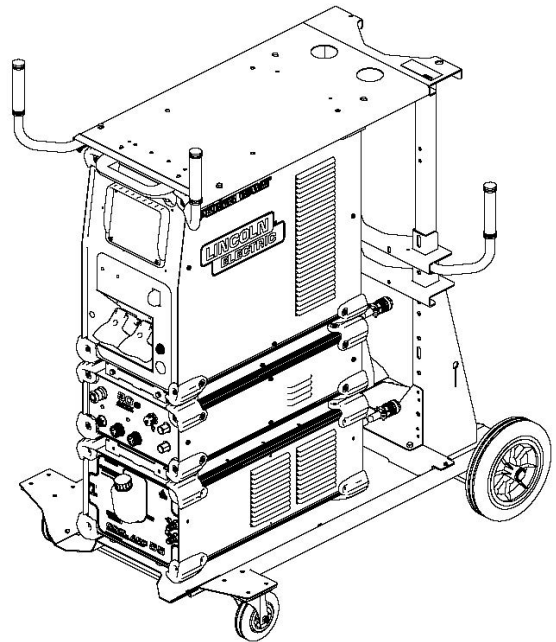

FIGURE 6 - Inverter Cart System Complete

**Power Source**

The power source will be installed either onto the base or on top of the optional modules (if installed). Set the power source into the mounting holes provided and push backwards to seat the module.

**Cart Top Bracket – Inverter Cart**

To affix the Power Wave® power source in place, attach the top bracket of the cart. Remove the screws from the top of the Power Wave front handle. Secure the top bracket of the cart with the provided screws. Adjust the sliding back brace of the cart so that it is in line with the cart top. Verify that the cart top lines up with both the screw holes on the sliding back brace and the holes from the handles removed earlier. Secure the top bracket in place. See **FIGURE 4** (on page B-2) - **Inverter Cart System Assembly**.

**Cart Top Bracket – Lift Cart**

To affix the Power Wave power source in place, attach the support bracket to the Power Wave power source using the existing screws from the Power Wave unit’s handle. Then secure the bracket to the cart post using the included hardware. See **FIGURE 5 - Lift Cart System Assembly**.

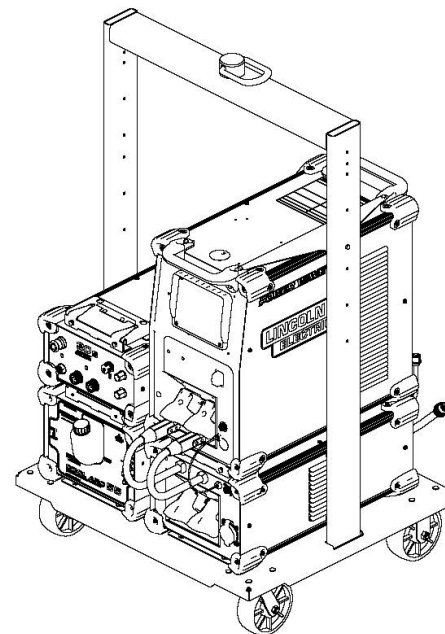

FIGURE 7 - Lift Cart System Complete

### Cable Installation

The system is shipped out with cables connected, however the components can be ordered separately and installed by the end user, or the cables and components may be removed during routine maintenance. For the complete system cable map – see **FIGURES 8 and 9 - System Assembly**.

Note:

- Always use the shortest cable lengths possible. DO NOT coil excess cable. It is recommended that the total length of control cable does not exceed 100' (30.5M). The use of non-standard cables in excess of 25' (7.5M) can lead to communication problems (system shutdowns), poor motor acceleration (poor arc starting), and low wire driving force (wire feeding problems).
- Best results will be obtained when the control cables are routed separate from the weld cables. This minimizes the possibility of interference between the high currents flowing through the weld cables and the low level signals in the control cables.:

ArcLink cables can be used to extend the pendant cable length.

### Cable List

1. **Pendant Cable** - Connects from the pendant to the control unit
2. **Control Cable** - Connects from the weld head to the control unit
3. **Torch Assembly** - Runs from the control unit out to the weld head. Includes power, sense lead, gas and water lines
4. **Work Cable\*** - Connects from the POWER WAVE unit (or Advanced Process Module if installed) to the work piece
5. **3-Phase Power Cable\*** - Connects power supply to facility power (refer to power supply manual for installation)
6. **Gas Hose\*** - Supplies gas to the system from external source
7. **Ethernet Cable\*** - Optional cable to connect the power supply to a local area network for added system functionality

\* Indicates items not included with the system

STANDARD LINCOLN CABLES		
Torch & Cables	Part Number	Location #
Pendant Cable 25'	K52130-25	1
Pendant Cable 15'	K52130-15	1
Control Cable 15' (4.6 m)	K52107-15	2
Control Cable 25' (7.6 m)	K52107-25	2
TIG Torch Assembly	AP01485-25	3
Power Cable 10'	K1824-10	4
Power Cable 35'	K1824-35	4
Power Cable 60'	K1824-60	4
Power Cable 110'	K1824-110	4

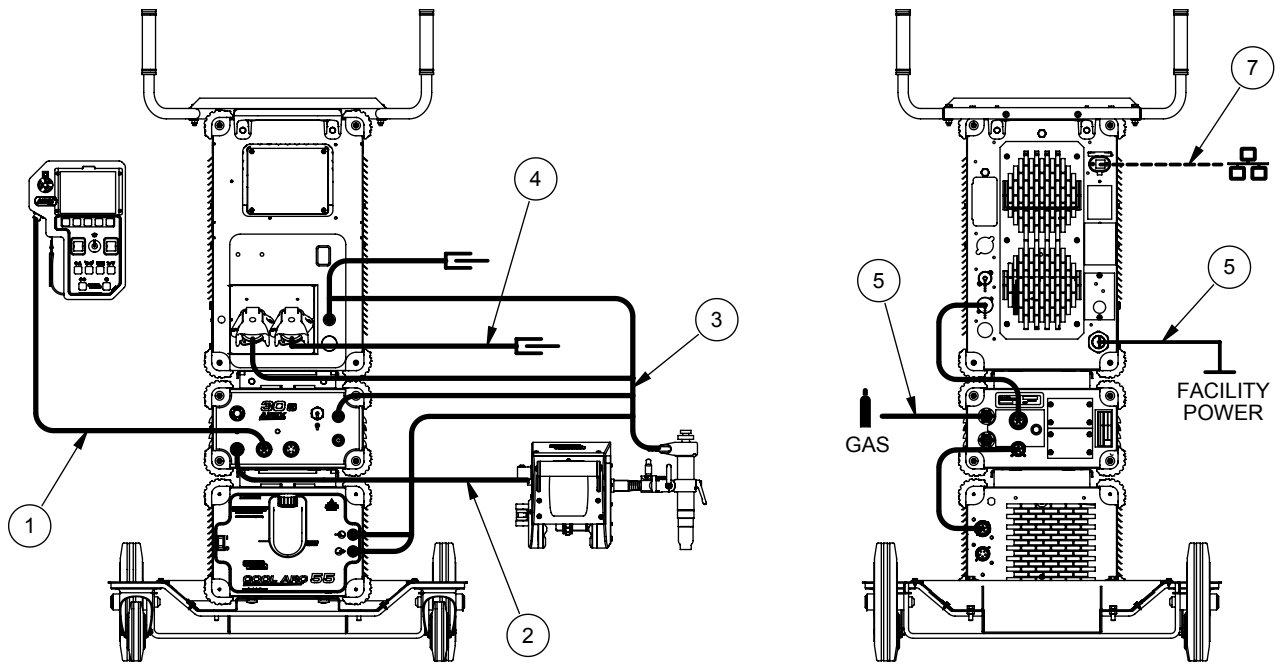

FIGURE 8 - Inverter Cart System

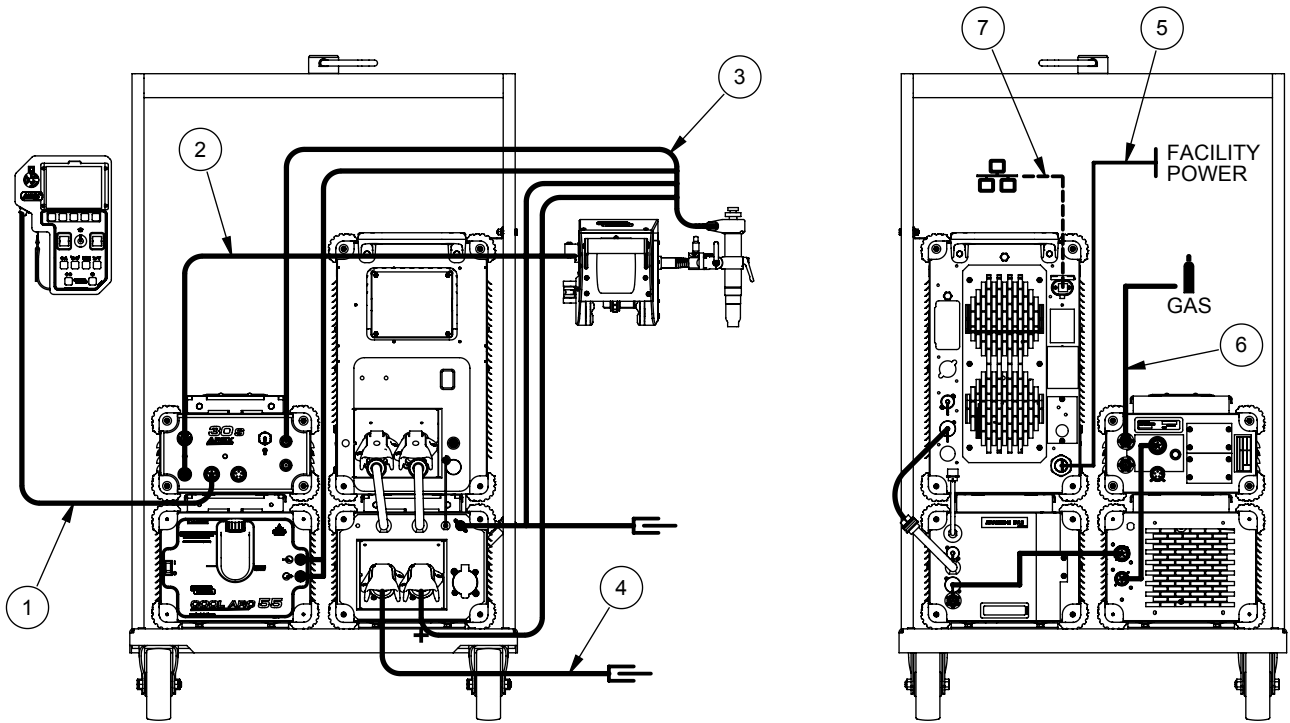

FIGURE 9 - Lift Cart System



## Shielding Gas Connection

### WARNING



CYLINDER MAY EXPLODE IF DAMAGED.

- Keep cylinder upright and chained to support.
- Keep cylinder away from areas where it may be damaged.
- Never lift welder with cylinder attached.
- Never allow welding electrode to touch cylinder.
- Keep cylinder away from welding or other live electrical circuits.
- **THE BUILD UP OF SHIELDING GAS MAY HARM HEALTH OR KILL.**



- Shut off shielding gas supply when not in use.
- See American National Standard Z-49.1, "Safety in Welding and Cutting" Published by the American Welding Society.

-----  
**MAXIMUM INLET PRESSURE IS 100 PSI. (6.9 BAR.)**

Install the shielding gas supply as follows:

1. Secure the cylinder to prevent it from falling.
2. Remove the cylinder cap. Inspect the cylinder valves and regulator for damaged threads, dirt, dust, oil or grease. Remove dust and dirt with a clean cloth. **DO NOT ATTACH THE REGULATOR IF OIL, GREASE OR DAMAGE IS PRESENT!** Inform your gas supplier of this condition.
3. Stand to one side away from the outlet and open the cylinder valve for an instant. This blows away any dust or dirt which may have accumulated in the valve outlet.
4. Attach the flow regulator to the cylinder valve and tighten the union nut(s) securely with a wrench.

**Note:** if connecting to 100 percent CO<sub>2</sub> cylinder, insert regulator adapter between regulator and cylinder valve. If adapter is equipped with a plastic washer, be sure it is seated for connection to the CO<sub>2</sub> cylinder.

5. Attach one end of the inlet hose to the outlet fitting of the flow regulator. Attach the other end to the welding system shielding gas inlet. Tighten the union nuts with a wrench.
6. Before opening the cylinder valve, turn the regulator adjusting knob counterclockwise until the adjusting spring pressure is released.
7. Standing to one side, open the cylinder valve slowly a fraction of a turn. When the cylinder pressure gage stops moving, open the valve fully.
8. The flow regulator is adjustable. Adjust it to the flow rate recommended for the procedure and process being used before making a weld.

# Maintenance

The APEX30S Control is designed for trouble-free operation and normally requires minimal preventive care and cleaning. This section provides instructions for maintaining user serviceable items. The suggested repair procedure for all such items is to remove and replace defective assemblies or parts. When users and/or service personnel are not familiar with electrical and electronic equipment, the product should be returned to the factory or serviced by factory authorized representatives.

## Maintenance Schedule

The maintenance schedule is suggested as a guideline for proper system maintenance. More stringent maintenance requirements may be required depending on the work being performed and the requirements of the customer for whom the work is performed. All maintenance schedules are based on a 40-hour work week.

Any excess play in parts or equipment should be noted and reported to an authorized repair facility. Any anomalous activity, such as motor hesitation, clicking or other noises, or anything out of the ordinary should be noted and reported to an authorized repair facility.

### Every Shift

- Check lines, cables, and hoses for loose connections and worn areas.

### Monthly

- Examine all hose connections to verify that there are no gas leaks. Make sure all cables are seated correctly and that there is no visible wear and tear to any connector or associated cables.

Observe all Safety Guidelines detailed throughout this manual

## Using the Status LED to Troubleshoot System Problems

The APEX 30S controller and the Power Wave unit are equipped with status LED. If a problem occurs, it is important to note the condition of the status LED – see **FIGURE 2 - Front Panel, item 5 on page B-1**. Before cycling power to the system, check the power source status LED for error sequences as noted below.

Included in this section is information about the Weld Head and ArcLink device status LEDs and a basic troubleshooting chart for both the machine and the weld performance. The LEDs are dual-colored and indicate system errors. Normal operation for each is steady green. Error conditions are indicated in **FIGURE 10- Status LED Light Conditions**.

**FIGURE 10 - Status LED Light Conditions**

LIGHT CONDITION	MEANING
Steady Green	System is OK. The power source is operational and is communicating normally with all peripheral equipment connected to its ArcLink device network.
Blinking Green	Occurs during power up or a system reset and indicates the Power Wave unit is mapped (identifying) each component in the system. This is normal for the first 1 to 60 seconds after the power is turned on, or if the system configuration is changed during operation.
Fast Blinking Green	Under normal conditions it indicates that Auto-mapping has failed. It is also used by Weld Manager Utilities. More information is available on the Service Navigator CDs or visit <a href="http://www.powerwavesoftware.com">www.powerwavesoftware.com</a> .
Alternating Red and Green	<p>Non-recoverable system fault. If the status lights are flashing any combination of red and green, errors are present. Read and note the error code(s) before turning off the machine.</p> <p>Error code interpretation through the status light is detailed in the service manual. Individual code digits are flashed in red with a long pause between digits. If more than one code is present, the codes will be separated by a green light. Only active error conditions are accessible through the status light.</p> <p>Error codes can also be retrieved with the Weld Manager Utility, included on the Service Navigator CDs. For the most updated error code log information, please visit: <a href="http://www.powerwavesoftware.com">www.powerwavesoftware.com</a>.</p> <p>To clear the active error(s), turn the power source off and back on to reset the system.</p>
Steady Red	Not applicable.
Blinking Red	Not applicable.

### CAUTION

If for any reason you do not understand the test procedures or are unable to perform the tests/repairs safely, contact your **Local Lincoln Authorized Field Service Facility** for technical troubleshooting assistance before you proceed.

Observe all Safety Guidelines detailed throughout this manual

## Weld Head Status LED Error Codes

Error ID	Description	Potential Solution
5-3-1	Weld head network not recognized by controller. Weld head has no power.	Check to make sure the weld head cable is plugged in and that the APEX 30S controller has power via 110V AC aux connector (if applicable). Cycle power to Power Wave unit.
5-3-3	Communication with oscillation motor has halted.	Check weld head cable for potential bad connections. Cycle power.
5-3-4	Communication with height motor has halted.	Check weld head cable for potential bad connections. Cycle power.
5-3-5	Communication with travel motor has halted.	Check weld head cable for potential bad connections. Cycle power.
5-3-6	Calibrated fault with oscillation	Check weld head cable and cycle power.
5-3-7	Calibrated fault with height	Check weld head cable and cycle power.
5-3-8	Wire drive timeout	Check weld head cable and cycle power.
5-3-9	“Other”	Cycle power.
5-3-6	Calibrated fault with oscillation	Check weld head cable and cycle power.
5-3-7	Calibration fault with height	Check weld head cable and cycle power.
5-3-8	Wire drive timeout	Check weld head cable and cycle power.
5-3-9	“Other”	Cycle power.
5-4-1	Oscillation motor following error	Check for resistance on the torch arm. Oscillation speeds too high.
5-4-2	Oscillation motor overcurrent	Check power supplies, cycle power. Clear any resistance/debris from track and the weld head arm.
5-4-3	Oscillation motor overheat	Check welding conditions. Turn off power for 5 minutes.
5-4-4	Oscillation communications fault	Check weld head cable and make sure no extra power/noise is being discharged into the weld head.
5-4-5	Oscillation communications off	Check weld head cable and make sure no extra power/noise is being discharged into the weld head.
5-4-6	Oscillation was moved passed programmed limit	Recalibrate the system/cycle power. Make sure weld head arm moves all the way in and you have full range of movement.
5-4-7	Oscillation motor overvoltage	Check power supplies, cycle power. Clear any resistance/debris from track and the weld head arm.
5-4-8	Oscillation motor position sensor error	Cycle power. Make sure internal motor controller wire harnesses and connectors are secure.
5-4-9	Oscillation fault unknown	Check all of the above items. Cycle power. Contact a Service Representative at: <b>800-770-0063</b>

### CAUTION

If for any reason you do not understand the test procedures or are unable to perform the tests/repairs safely, contact your **Local Lincoln Authorized Field Service Facility** for technical troubleshooting assistance before you proceed.

Observe all Safety Guidelines detailed throughout this manual

5-5-1	Height motor following error	Check for resistance on the torch arm. Height movement speeds too high.
5-5-2	Height motor overcurrent	Check power supplies. Cycle power. Clear any debris from the track and the weld head arm.
5-5-3	Height motor overheat	Check welding conditions. Turn off power for 5 minutes.
5-5-4	Height communications fault	Check weld head cable and make sure no extra power/ noise is being discharged into the weld head.
5-5-5	Height communications off	Check weld head cable and make sure no extra power/ noise is being discharged into the weld head.
5-5-6	Height was moved passed programmed limit	Recalibrate the system/cycle power. Make sure weld head arm moves all the way in and you have full range of movement. Check Setup.
5-5-7	Height motor overvoltage	Check power supplies, cycle power. Clear any resistance/ debris from track and the weld head arm.
5-5-8	Height motor position sensor error	Cycle power. Make sure internal motor controller wire harnesses and connectors are secure.
5-5-9	Height fault unknown	Check all of the above items; cycle power. Contact a Service Representative at <b>800-770-0063</b> .
5-6-1	Travel motor following error	Check for resistance on the torch arm. Travel speeds too high.
5-6-2	Travel motor overcurrent	Check power supplies, cycle power. Clear any resistance/ debris from track and the weld head arm.
5-6-3	Travel motor overheat	Check welding conditions. Turn off power for 5 minutes.
5-6-4	Travel communications fault	Check weld head cable and make sure no extra power / noise is being discharged into the weld head.
5-6-5	Travel communications off	Check weld head cable and make sure no extra power / noise is being discharged into the weld head.
5-6-6	Travel was moved passed programmed limit	Recalibrate the system/cycle power. Make sure you can jog travel along your track.
5-6-7	Travel motor overvoltage	Check power supplies, cycle power. Clear any resistance/ debris from track and the weld head arm.
5-6-8	Travel motor position sensor error	Cycle power. Make sure internal motor controller wire harnesses and connectors are secure.
5-6-9	Travel fault unknown	Check all of the above items. Cycle Power. Contact a Service Representative at the number on the cover of this manual.
5-7-1	Wire motor following error	Check for resistance when pulling wire through the liner. Wire speeds too high.
5-7-2	Wire motor overcurrent	Check power supplies, cycle power. Check for wire bird-nest. Check for resistance when pulling wire through the liner.
5-7-3	Wire motor overheat	Check welding conditions. Turn off power for 5 minutes. Check for resistance when pulling wire through the liner.
5-7-4	Wire communications fault	Check Weld head cable and make sure no extra power / noise is being discharged into the Weld head.
5-7-5	Wire communications off	Check Weld head cable and make sure no extra power / noise is being discharged into the Weld head.

## CAUTION

If for any reason you do not understand the test procedures or are unable to perform the tests/repairs safely, contact your **Local Lincoln Authorized Field Service Facility** for technical troubleshooting assistance before you proceed.



Observe all Safety Guidelines detailed throughout this manual

5-7-6	Wire motor / encoder issue	Cycle power to the system and allow the system to recalibrate. Make sure you can jog wire in Jog mode.
5-7-7	Wire motor overvoltage	Check power supplies, cycle power. Check for wire bird-nest. Check for resistance when pulling wire through the liner.
5-7-8	Wire motor / encoder issue	Cycle power to the system and allow the system to recalibrate. Make sure you can jog wire in Jog mode.
5-7-9	Wire fault unknown	Check all of the above items. Cycle Power. Contact a Service Representative at: <b>800-770-0063</b> .
6-3-3-1	Unstable or “noisy” WFS feedback signal	Check the cables and connections. Cycle power.
8-1	Motor Overload (Long Term)	Check the electrode feeds easily through feed system. Verify the wire reel bracket is not too tight. Verify the quality of electrode. We recommend only Lincoln Electric brand..
8-2	Motor Overload (Short Term)	Check that motor can turn freely when idle arm is open. Check gears for dirt and debris. Check for error 8.1.
8-3	Shutdown #1 is open	Contact a Service Representative at: <b>800-770-0063</b> .
8-4	Shutdown #2 is open	Contact a Service Representative at <b>800-770-0063</b> .

## CAUTION

If for any reason you do not understand the test procedures or are unable to perform the tests/repairs safely, contact your **Local Lincoln Authorized Field Service Facility** for technical troubleshooting assistance before you proceed.

Wiring Diagram 12835

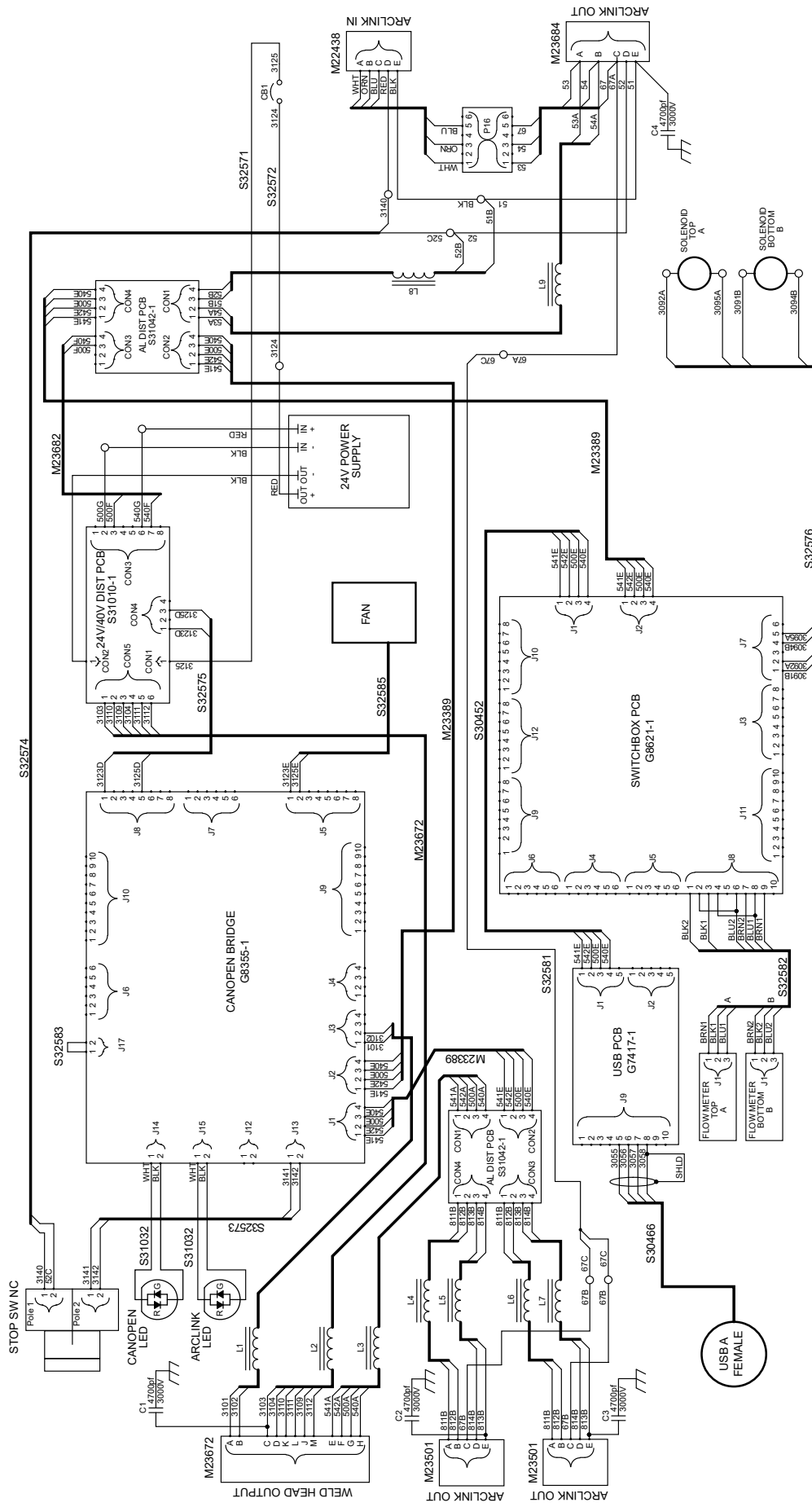

NOTE: This diagram is for reference only. It may not be accurate for all machines covered by this manual. If the diagram is illegible, write to the Service Department for a replacement. Give the equipment code number.

Wiring Diagram 13215

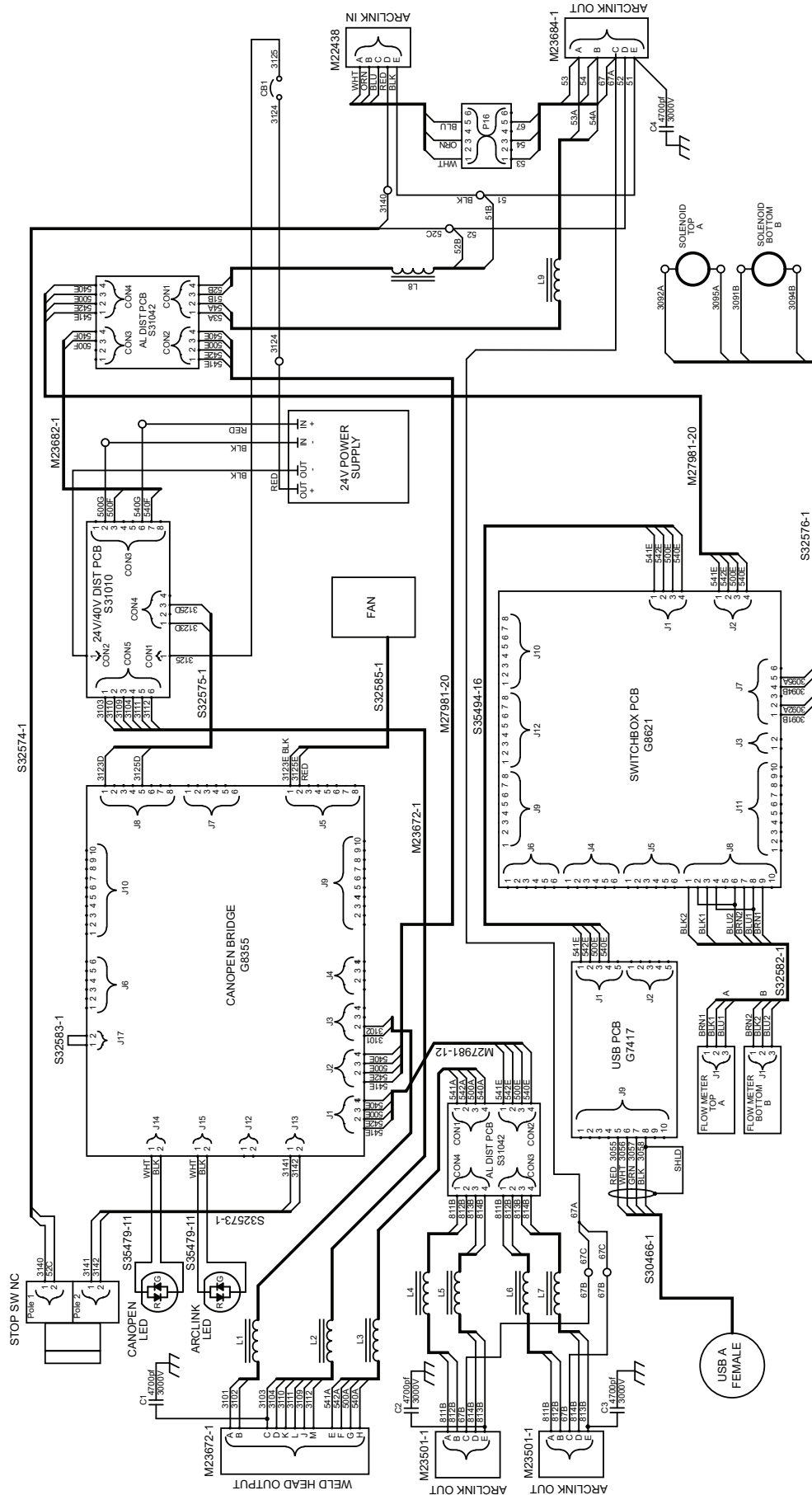

NOTE: This diagram is for reference only. It may not be accurate for all machines covered by this manual. If the diagram is illegible, write to the Service Department for a replacement. Give the equipment code number.

Wiring Diagram 13410

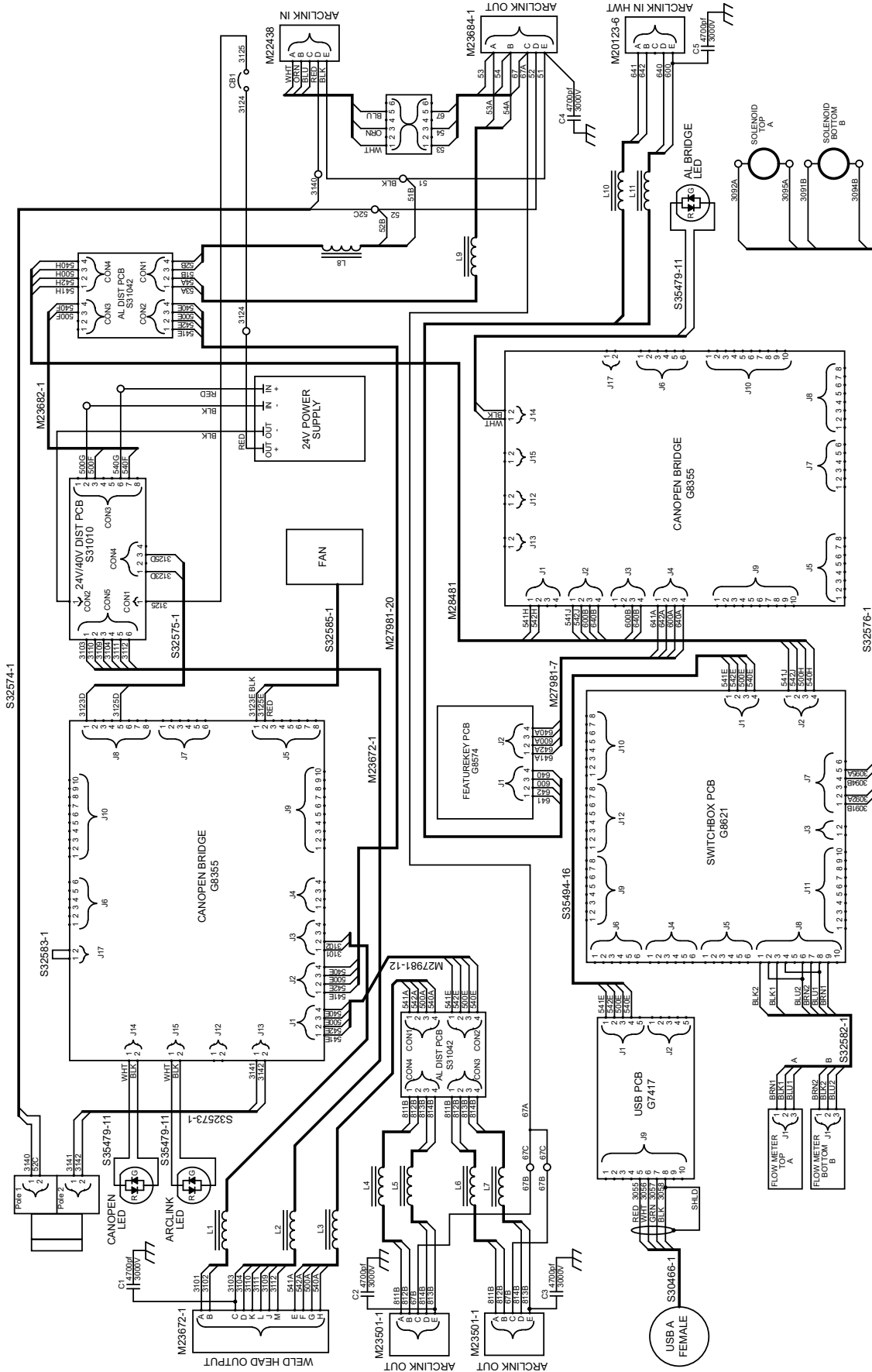

NOTE: This diagram is for reference only. It may not be accurate for all machines covered by this manual. If the diagram is illegible, write to the Service Department for a replacement. Give the equipment code number.

# WIRING DIAGRAM - APEX 30S, CODE 13703

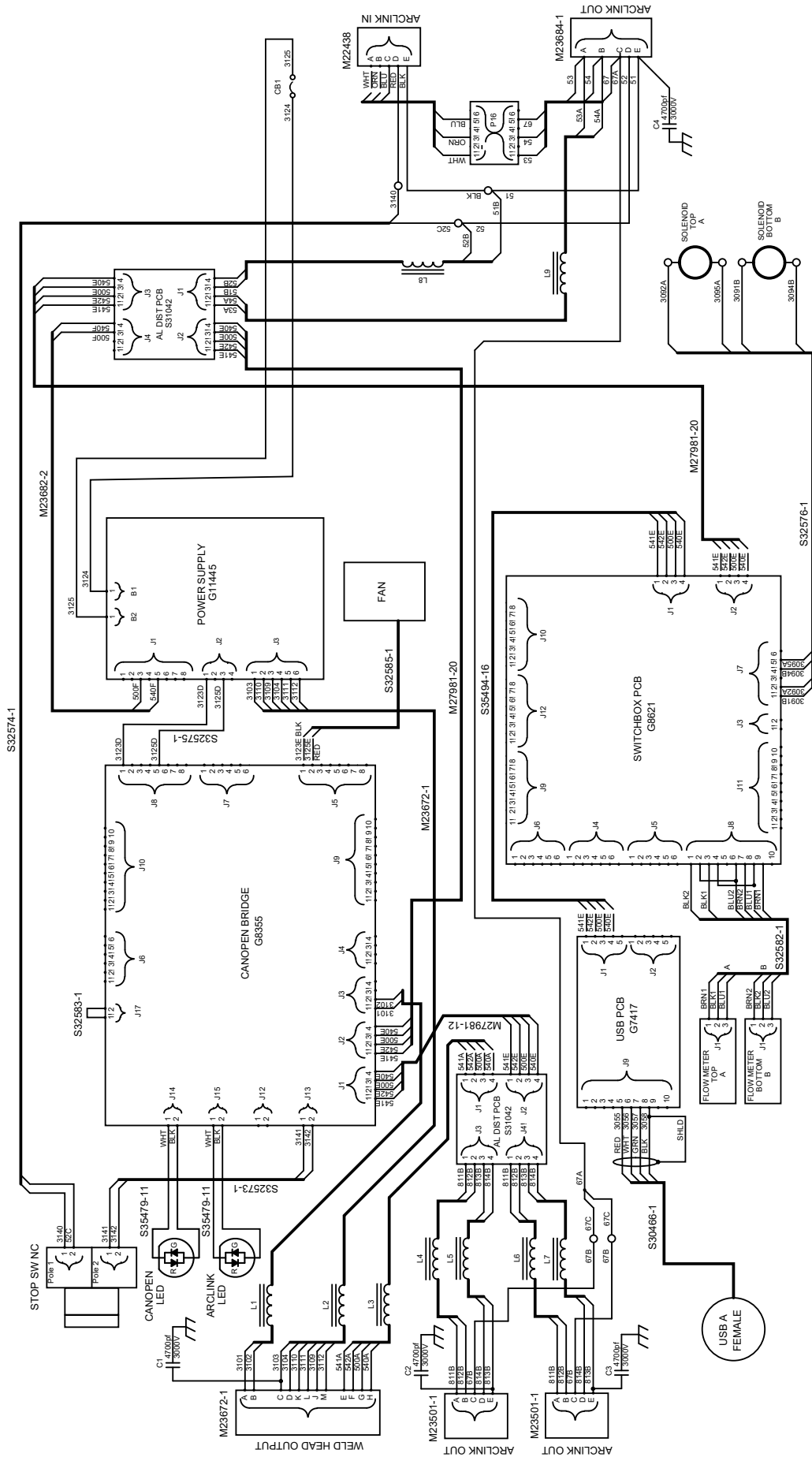

**NOTE:** This diagram is for reference only. It may not be accurate for all machines covered by this manual. If the diagram is illegible, write to the Service Department for a replacement. Give the equipment code number.



# WIRING DIAGRAM - APEX 30S NNS, CODE 13653

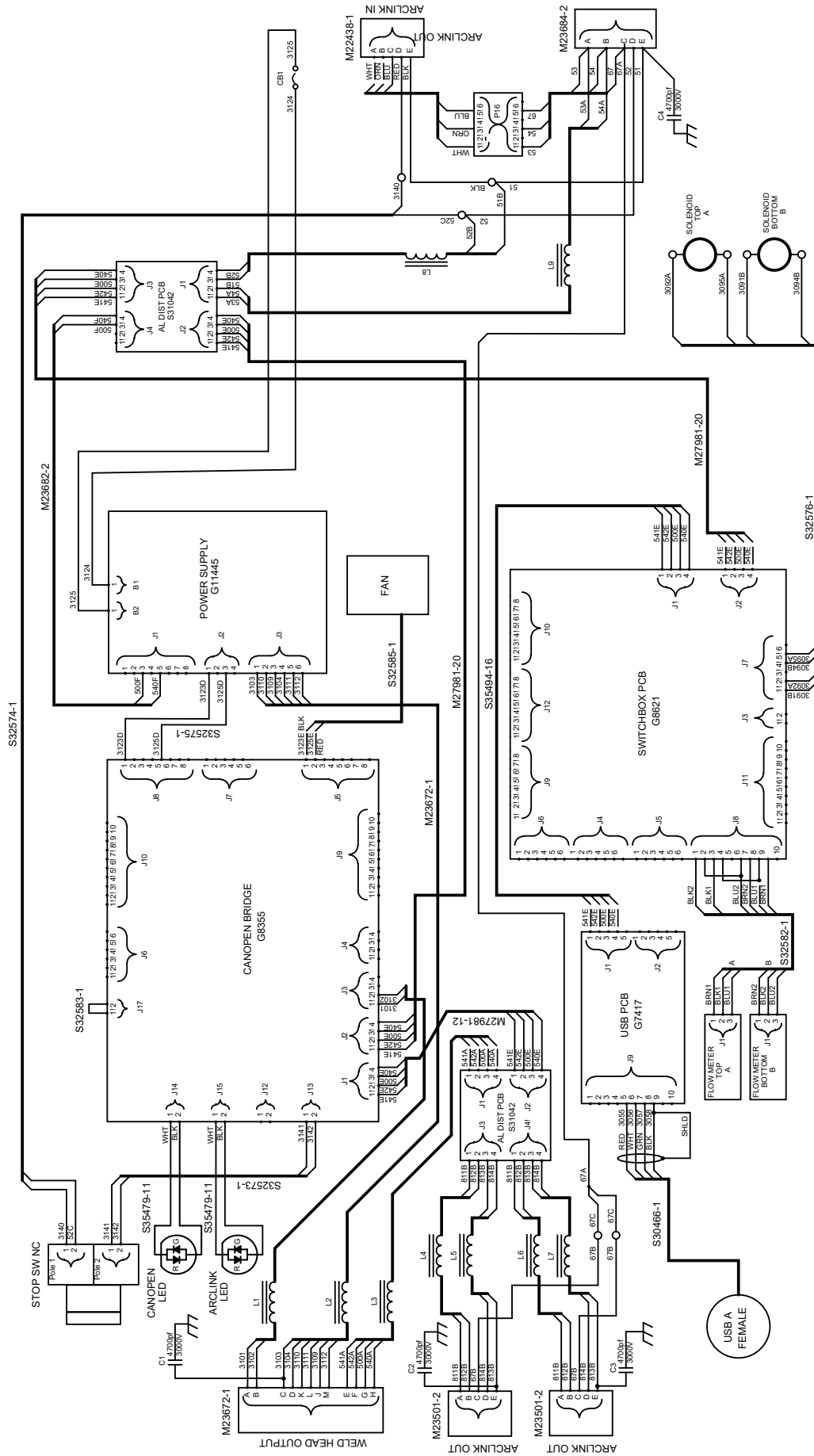

**NOTE:** This diagram is for reference only. It may not be accurate for all machines covered by this manual. If the diagram is illegible, write to the Service Department for a replacement. Give the equipment code number.



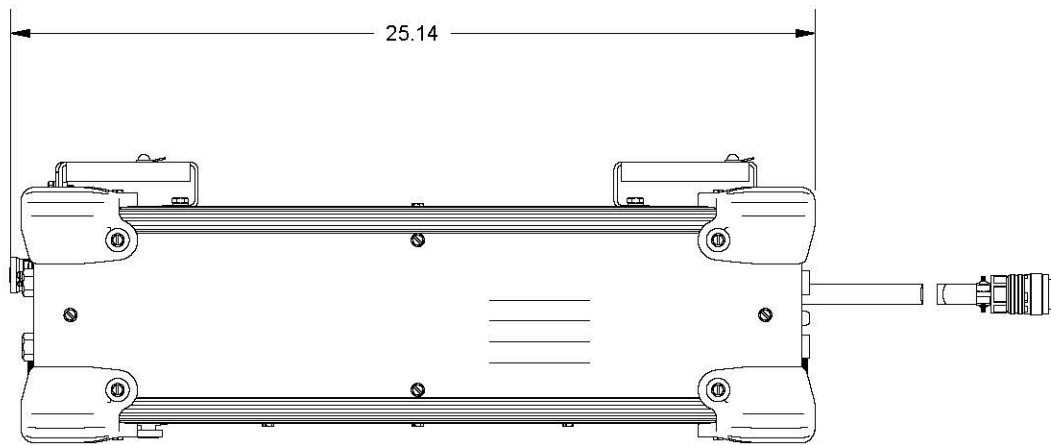
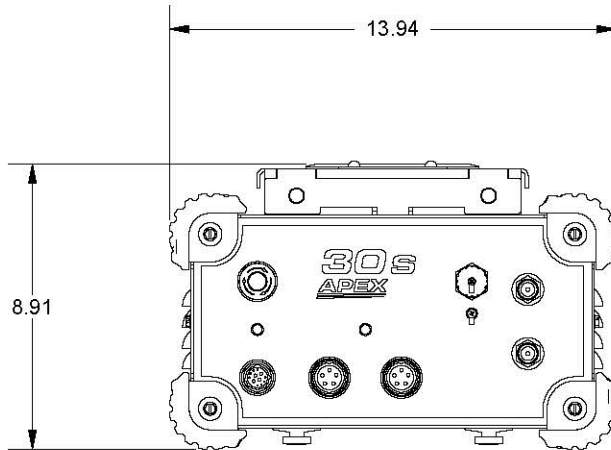

APEX® 30S Controller Dimensions

## WEEE

<p>English</p> 	<p style="text-align: right;">07/06</p> <p>Do not dispose of electrical equipment together with normal waste! In observance of European Directive 2002/96/EC on Waste Electrical and Electronic Equipment (WEEE) and its implementation in accordance with national law, electrical equipment that has reached the end of its life must be collected separately and returned to an environmentally compatible recycling facility. As the owner of the equipment, you should get information on approved collection systems from our local representative. By applying this European Directive you will protect the environment and human health!</p>
--------------------------------------------------------------------------------------------------	--------------------------------------------------------------------------------------------------------------------------------------------------------------------------------------------------------------------------------------------------------------------------------------------------------------------------------------------------------------------------------------------------------------------------------------------------------------------------------------------------------------------------------------------------------------------------------------------------------------------------------------------------------------

# APEX® 30S CONTROL PARTS MANUAL

**This parts list is provided as an informative guide only.**

CODE 12835  
FINAL ASSEMBLY

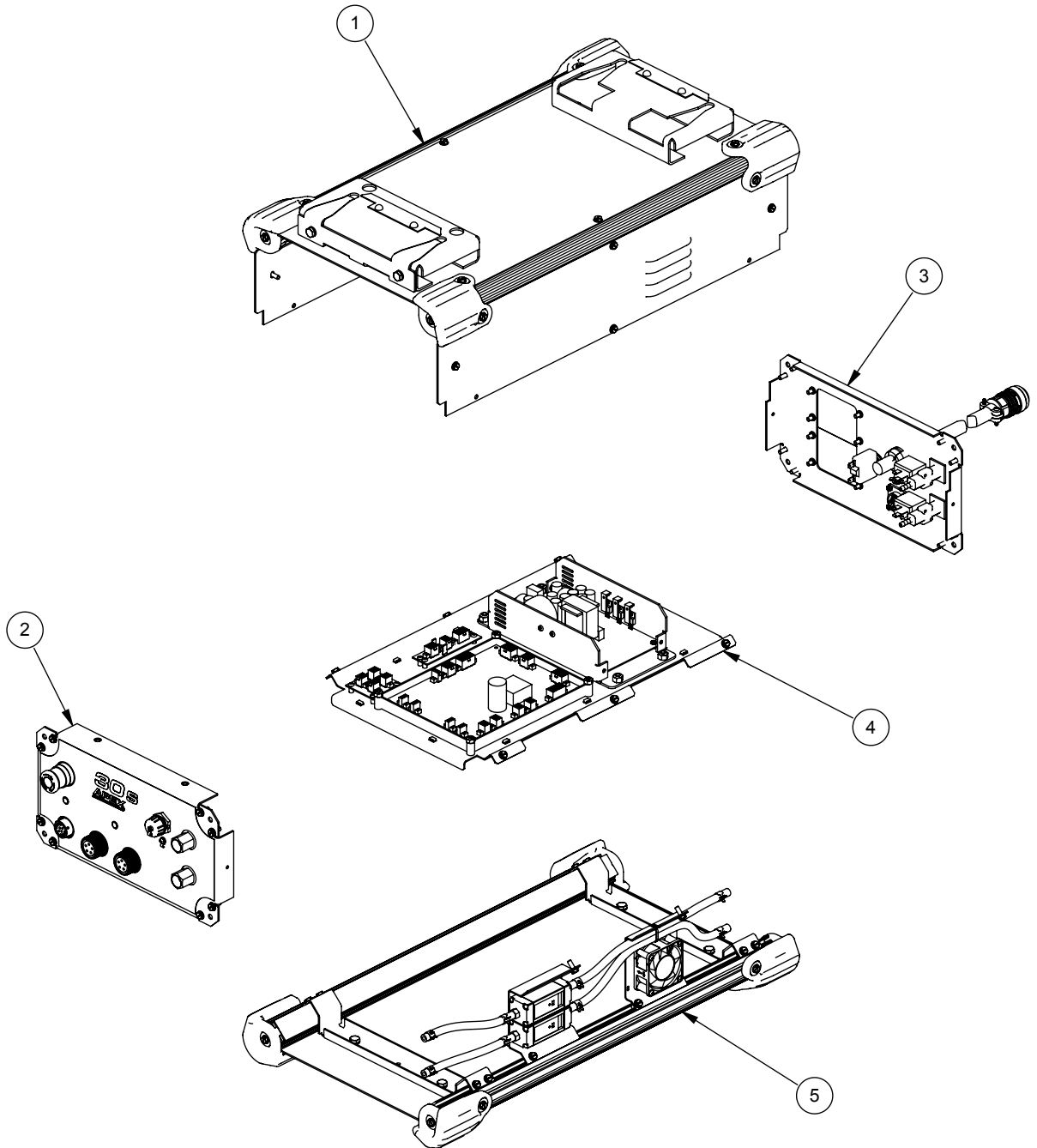

**NOTE:** This Parts Manual is provided as an informative guide only. When ordering parts always refer to the Lincoln Electric Parts List.

# APEX® 30S CONTROL

FINAL ASSEMBLY

For Code:12835

Do not use this Parts List for a machine if its code number is not listed. Contact the Service Department for any code numbers not listed.

Use the illustration of Sub-Assemblies page and the table below to determine which sub assembly page and column the desired part is located on for your particular code machine.

Sub Assembly Item Number	1	2	3	4	5				
SUB ASSEMBLY PAGE NAME	Case Top Assembly	Front Panel Assembly	Rear Panel Assembly	Subpanel Assembly	Base Assembly				
PAGE NO.	P-4	P-6	P-8	P-10	P-12				
CODE NO.									
12835	1	1	1	1	1				

**NOTE:** This Parts Manual is provided as an informative guide only. When ordering parts always refer to the Lincoln Electric Parts List.



CASE TOP ASSEMBLY

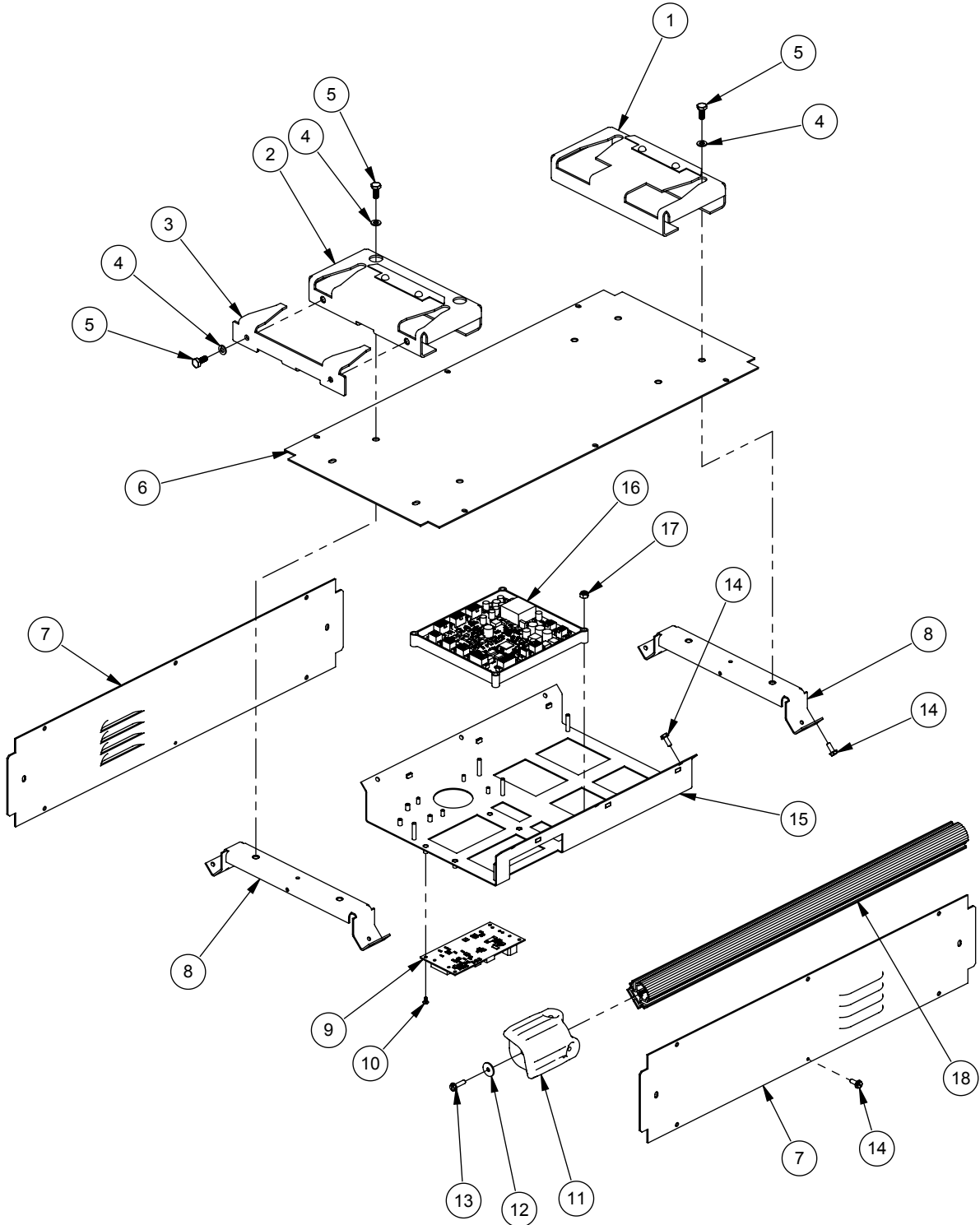

**NOTE:** This Parts Manual is provided as an informative guide only. When ordering parts always refer to the Lincoln Electric Parts List.

## CASE TOP ASSEMBLY

# Indicates a change in this print-

Use only the parts marked "x" in the column under the heading number called for in the model index

ITEM	DESCRIPTION	PART NO.	QTY	1
1	Rear Mounting Bracket Assembly	9SS28459	1	X
2	Front Mounting Bracket Assembly	9SS28458	2	X
3	Locking Bracket	9SS28375	2	X
4	Lock Washer	9SE106A-27	10	X
5	Hex Head Screw	9SCF000013	10	X
6	Roof	9SL12763-3	1	X
7	Case Side	9SM23613	2	X
8	Bracket	9SL15091-1	2	X
9	USB PC Board Assembly	9SS31189	1	X
10	Self Tapping Screw	9SS8025-80	4	X
11	Corner Cap	9SL13138	4	X
12	Plain Washer	9SS9262-182	12	X
13	Self Tapping Screw	9SS9225-100	12	X
14	Self Tapping Screw	9SS9225-99	18	X
15	Top Tray	9SM23614	1	X
16	Switch Box PCB Assembly	9SS31390	1	X
17	#10-24 Locknut Nylon Insert	9ST9187-13	4	X
18	Base Extrusion	9SM21251-2	2	X

**NOTE:** This Parts Manual is provided as an informative guide only. When ordering parts always refer to the Lincoln Electric Parts List.

FRONT PANEL ASSEMBLY

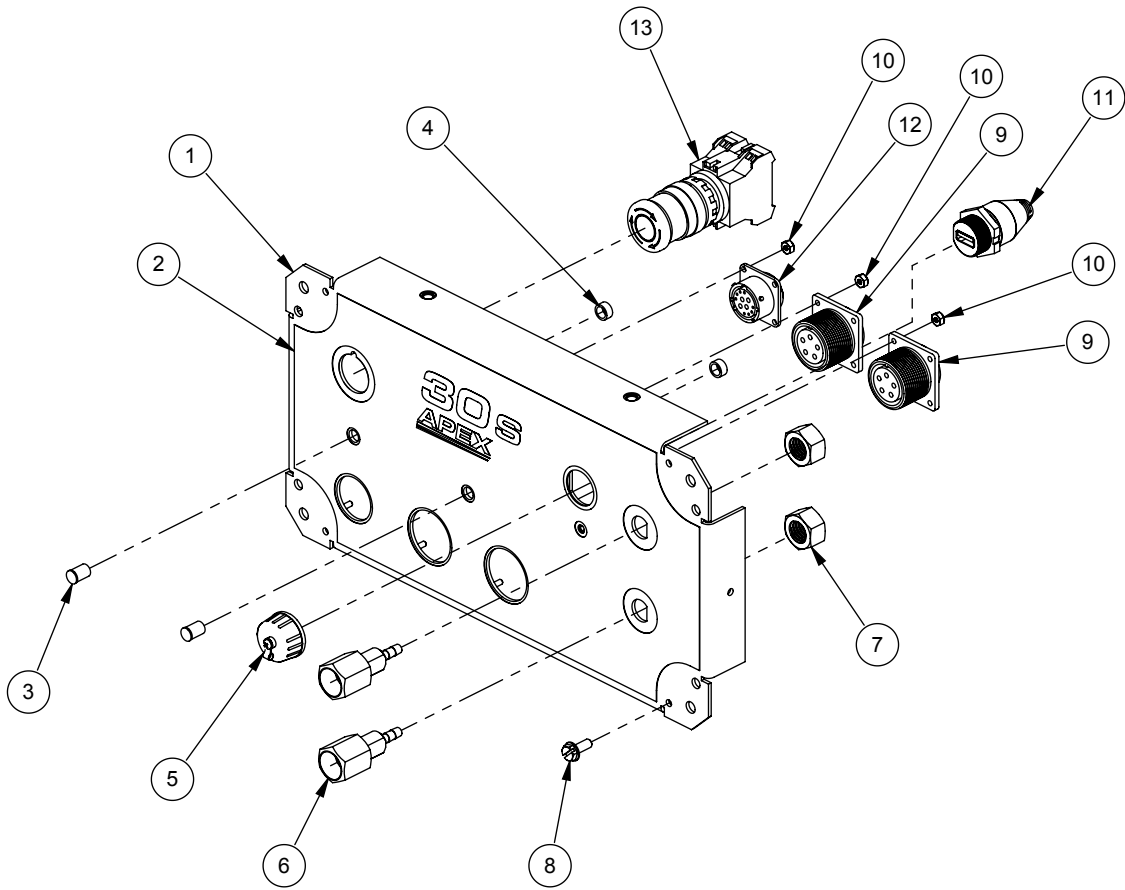

**NOTE:** This Parts Manual is provided as an informative guide only. When ordering parts always refer to the Lincoln Electric Parts List.

FRONT PANEL ASSEMBLY

# Indicates a change in this print-

Use only the parts marked "x" in the column under the heading number called for in the model index

ITEM	DESCRIPTION	PART NO.	QTY	1
1	Case Front	9SM23596	1	X
2	Front Decal	9SM23598	1	X
3	Led Lens	9SS23093-1	2	X
4	Led Retaining O-Ring	9SS23094-1	2	X
5	USB Cable Cover	9SS31791	1	X
6	Connector	9ST14557-3	2	X
7	1/2-13HN	9SCF000027	2	X
8	Self Tapping Screw	9SS9225-99	8	X
9	Output Harness	9SM23501	2	X
10	#4-40 Locknut Nylon Insert	9SS31350-17	12	X
11	USB Input Harness	9SS30466	1	X
12	Tractor Control Harness	9SM23672	1	X
13	E-Stop Switch	9SM20853	1	X

**NOTE:** This Parts Manual is provided as an informative guide only. When ordering parts always refer to the Lincoln Electric Parts List.

REAR PANEL ASSEMBLY

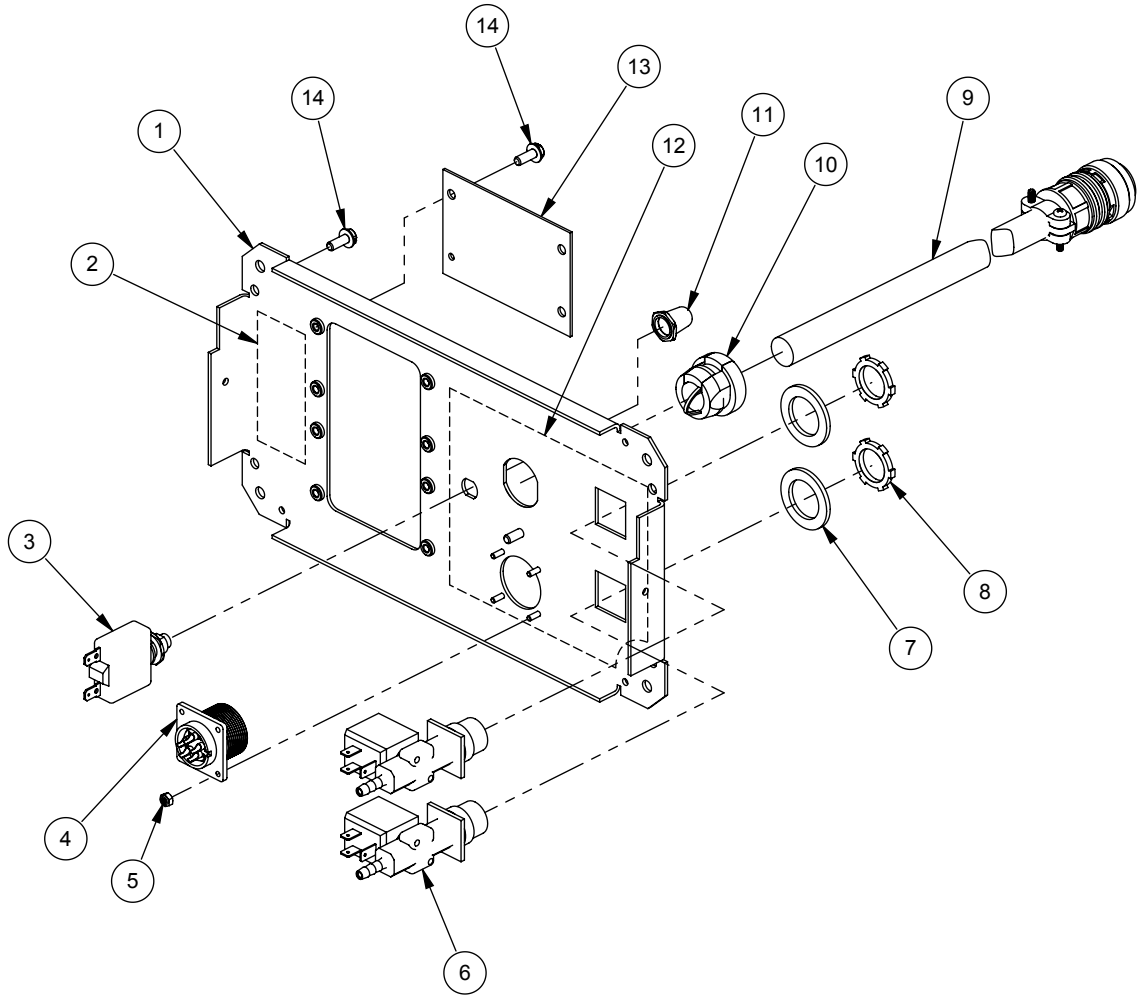

**NOTE:** This Parts Manual is provided as an informative guide only. When ordering parts always refer to the Lincoln Electric Parts List.

## REAR PANEL ASSEMBLY

# Indicates a change in this print-

Use only the parts marked "x" in the column under the heading number called for in the model index

ITEM	DESCRIPTION	PART NO.	QTY	1
1	Case Rear	9SM23599	1	X
2	Rating Plate	9SM23615	1	X
3	Circuit Breaker 10A	9ST12287-20	1	X
4	Output Harness	9SM23684	1	X
5	#4-40 Locknut Nylon Insert	9SS31350-17	4	X
6	Solenoid Valve	9SM17294-8	2	X
7	Plain Washer	9SS9262-149	2	X
8	Conduit Locknut	9ST14370-1	2	X
9	Arc Link Cable Asbly	9SM22438	1	X
10	Grommet	9ST9274-8	1	X
11	Sealing Boot	9SS22061-3	1	X
12	Rear Decal	9SM23601	1	X
13	Blank Plate	9SS32273	2	X
14	Self Tapping Screw	9SS9225-99	16	X

**NOTE:** This Parts Manual is provided as an informative guide only. When ordering parts always refer to the Lincoln Electric Parts List.

SUBPANEL ASSEMBLY

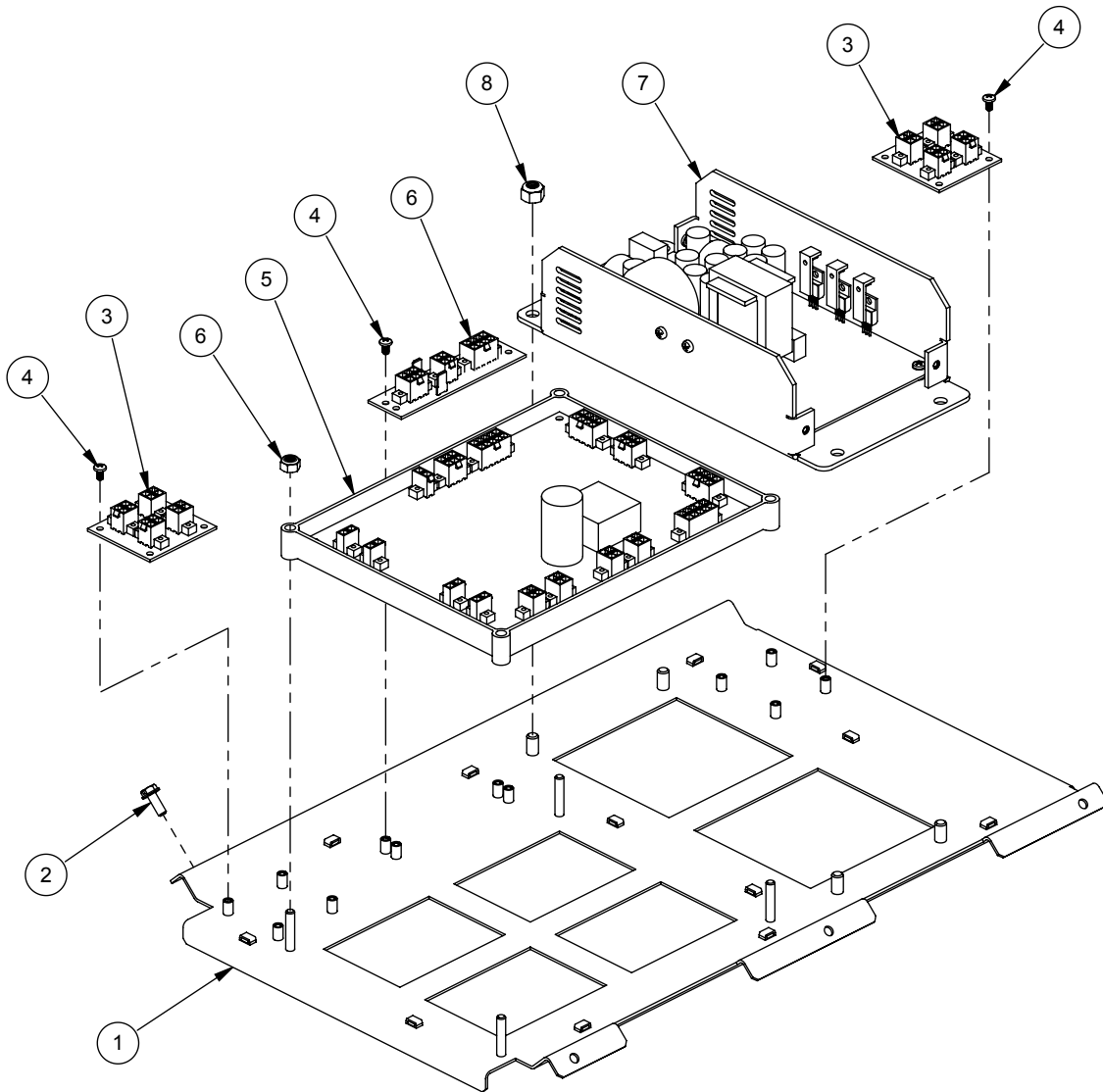

**NOTE:** This Parts Manual is provided as an informative guide only. When ordering parts always refer to the Lincoln Electric Parts List.



**SUBPANEL ASSEMBLY**

# Indicates a change in this print-

Use only the parts marked “x” in the column under the heading number called for in the model index

ITEM	DESCRIPTION	PART NO.	QTY	1
1	Subpanel	9SM23608	1	X
2	Self Tapping Screw	9SS9225-99	6	X
3	ArcLink Distribution Board	9SS31042-1	2	X
4	Self Tapping Screw	9SS8025-80	12	X
5	Can Open Bridge PCB Assembly	9SS31338	1	X
6	40V 24V Distribution Board	9SS31010-1	1	X
7	Power Supply	9SS31750	1	X
8	1/4-20 Locknut Nylon Insert	9ST9187-16	4	X

**NOTE:** This Parts Manual is provided as an informative guide only. When ordering parts always refer to the Lincoln Electric Parts List.

BASE ASSEMBLY

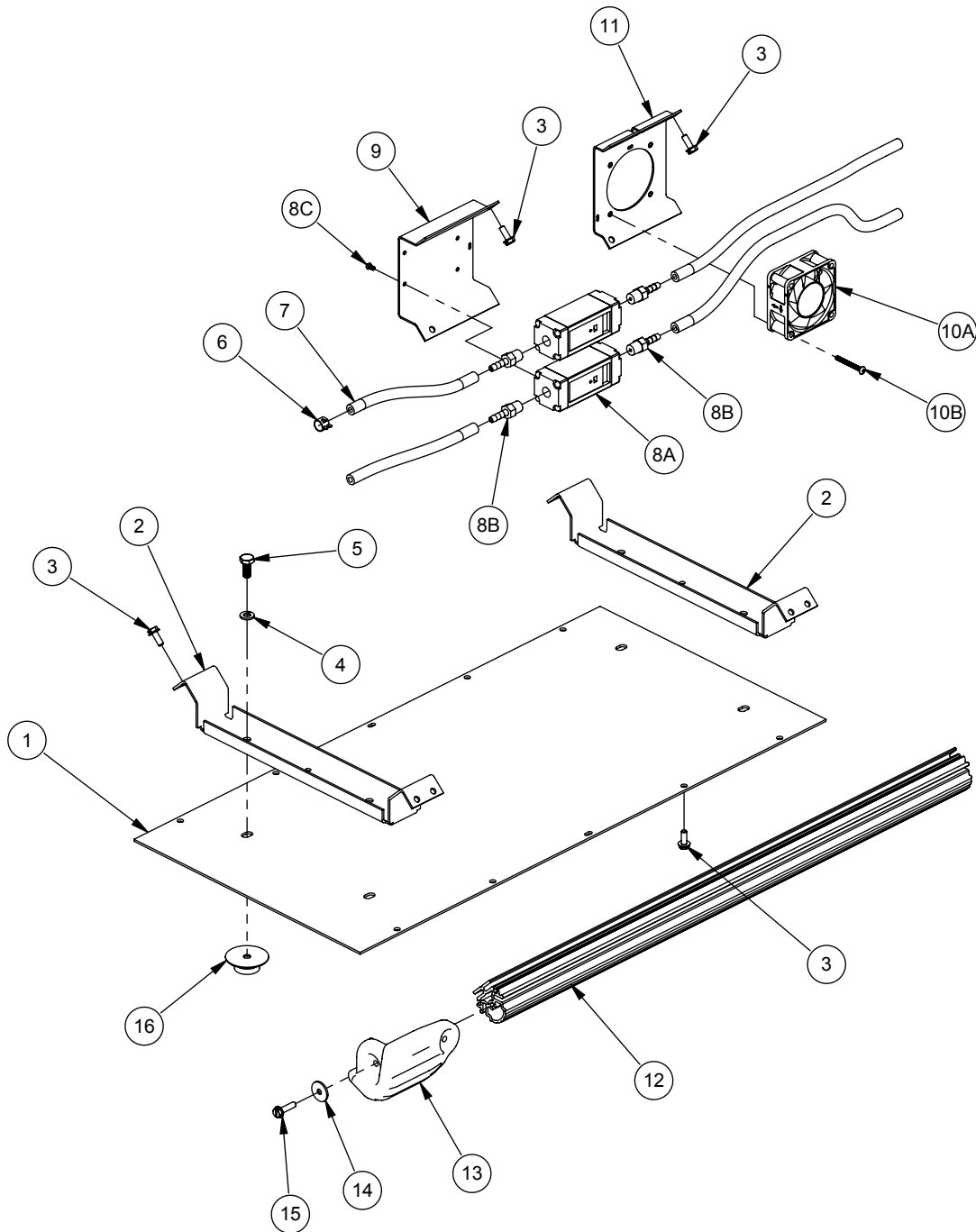

**NOTE:** This Parts Manual is provided as an informative guide only. When ordering parts always refer to the Lincoln Electric Parts List.

## BASE ASSEMBLY

# Indicates a change in this print-

Use only the parts marked "x" in the column under the heading number called for in the model index

ITEM	DESCRIPTION	PART NO.	QTY	1
1	Base	9SS32272	1	X
2	Bracket	9SL15091	2	X
3	Self Tapping Screw	9SS9225-99	18	X
4	Lock Washer	9SE106A-27	4	X
5	Hex Head Screw	9SCF000013	4	X
6	Hose Clamp	9ST13777-8	8	X
7	Gas Hose (33 in)	9ST10642-265	1	X
8	Gas Flow Sensor, Includes:	K3338-1	2	X
8A	Flow Sensor	NSS	2	X
8B	Hose Nipple-Male	9ST14557-8	4	X
8C	Pan Head Screw	NSS	4	X
9	Flow Sensor Bracket	9SM23611	1	X
10	Fan Kit, Includes:	9SS32586	1	X
11	Fan	NSS	1	X
12	Pan Head Screw	NSS	4	X
13	Fan Bracket	9SM23609	1	X
14	Base Extrusion	9SM21251-2	2	X
15	Corner Cap	9SL13138	4	X
16	Plain Washer	9SS9262-182	12	X
17	Self Tapping Screw	9SS9225-100	12	X
18	Quick Lock Foot	9SS28070	4	X

**NOTE:** This Parts Manual is provided as an informative guide only. When ordering parts always refer to the Lincoln Electric Parts List.

This page intentionally left blank

This page intentionally left blank

<b>WARNING</b>	<ul style="list-style-type: none"> <li>● Do not touch electrically live parts or electrode with skin or wet clothing.</li> <li>● Insulate yourself from work and ground.</li> </ul>	<ul style="list-style-type: none"> <li>● Keep flammable materials away.</li> </ul>	<ul style="list-style-type: none"> <li>● Wear eye, ear and body protection.</li> </ul>
Spanish <b>AVISO DE PRECAUCION</b>	<ul style="list-style-type: none"> <li>● No toque las partes o los electrodos bajo carga con la piel o ropa mojada.</li> <li>● Aíslese del trabajo y de la tierra.</li> </ul>	<ul style="list-style-type: none"> <li>● Mantenga el material combustible fuera del área de trabajo.</li> </ul>	<ul style="list-style-type: none"> <li>● Protéjase los ojos, los oídos y el cuerpo.</li> </ul>
French <b>ATTENTION</b>	<ul style="list-style-type: none"> <li>● Ne laissez ni la peau ni des vêtements mouillés entrer en contact avec des pièces sous tension.</li> <li>● Isolez-vous du travail et de la terre.</li> </ul>	<ul style="list-style-type: none"> <li>● Gardez à l'écart de tout matériel inflammable.</li> </ul>	<ul style="list-style-type: none"> <li>● Protégez vos yeux, vos oreilles et votre corps.</li> </ul>
German <b>WARNUNG</b>	<ul style="list-style-type: none"> <li>● Berühren Sie keine stromführenden Teile oder Elektroden mit Ihrem Körper oder feuchter Kleidung!</li> <li>● Isolieren Sie sich von den Elektroden und dem Erdboden!</li> </ul>	<ul style="list-style-type: none"> <li>● Entfernen Sie brennbares Material!</li> </ul>	<ul style="list-style-type: none"> <li>● Tragen Sie Augen-, Ohren- und Körperschutz!</li> </ul>
Portuguese <b>ATENÇÃO</b>	<ul style="list-style-type: none"> <li>● Não toque partes elétricas e electrodos com a pele ou roupa molhada.</li> <li>● Isole-se da peça e terra.</li> </ul>	<ul style="list-style-type: none"> <li>● Mantenha inflamáveis bem guardados.</li> </ul>	<ul style="list-style-type: none"> <li>● Use proteção para a vista, ouvido e corpo.</li> </ul>
Japanese <b>注意事項</b>	<ul style="list-style-type: none"> <li>● 通電中の電気部品、又は溶材にヒフやぬれた布で触れないこと。</li> <li>● 施工物やアースから身体が絶縁されている様にして下さい。</li> </ul>	<ul style="list-style-type: none"> <li>● 燃えやすいものの側での溶接作業は絶対にしてはなりません。</li> </ul>	<ul style="list-style-type: none"> <li>● 目、耳及び身体に保護具をして下さい。</li> </ul>
Chinese <b>警告</b>	<ul style="list-style-type: none"> <li>● 皮肤或湿衣物切勿接触带电部件及焊条。</li> <li>● 使你自已与地面和工件绝缘。</li> </ul>	<ul style="list-style-type: none"> <li>● 把一切易燃物品移离工作场所。</li> </ul>	<ul style="list-style-type: none"> <li>● 佩戴眼、耳及身体劳动保护用具。</li> </ul>
Korean <b>위험</b>	<ul style="list-style-type: none"> <li>● 전도체나 용접봉을 젖은 헝겍 또는 피부로 절대 접촉치 마십시오.</li> <li>● 모재와 접지를 접촉치 마십시오.</li> </ul>	<ul style="list-style-type: none"> <li>● 인화성 물질을 접근시키지 마십시오.</li> </ul>	<ul style="list-style-type: none"> <li>● 눈, 귀와 몸에 보호장구를 착용하십시오.</li> </ul>
Arabic <b>تحذير</b>	<ul style="list-style-type: none"> <li>● لا تلمس الاجزاء التي يسري فيها التيار الكهربائي أو الألكترود بجند الجسم أو بالملابس المبللة بالماء.</li> <li>● ضع عازلا على جسمك خلال العمل.</li> </ul>	<ul style="list-style-type: none"> <li>● ضع المواد القابلة للاشتعال في مكان بعيد.</li> </ul>	<ul style="list-style-type: none"> <li>● ضع أدوات وملابس واقية على عينيك وأذنيك وجسمك.</li> </ul>

**READ AND UNDERSTAND THE MANUFACTURER'S INSTRUCTION FOR THIS EQUIPMENT AND THE CONSUMABLES TO BE USED AND FOLLOW YOUR EMPLOYER'S SAFETY PRACTICES.**

**SE RECOMIENDA LEER Y ENTENDER LAS INSTRUCCIONES DEL FABRICANTE PARA EL USO DE ESTE EQUIPO Y LOS CONSUMIBLES QUE VA A UTILIZAR, SIGA LAS MEDIDAS DE SEGURIDAD DE SU SUPERVISOR.**

**LISEZ ET COMPRENEZ LES INSTRUCTIONS DU FABRICANT EN CE QUI REGARDE CET EQUIPMENT ET LES PRODUITS A ETRE EMPLOYES ET SUIVEZ LES PROCEDURES DE SECURITE DE VOTRE EMPLOYEUR.**

**LESEN SIE UND BEFOLGEN SIE DIE BETRIEBSANLEITUNG DER ANLAGE UND DEN ELEKTRODENEINSATZ DES HERSTELLERS. DIE UNFALLVERHÜTUNGSVORSCHRIFTEN DES ARBEITGEBERS SIND EBENFALLS ZU BEACHTEN.**

			
<ul style="list-style-type: none"> <li>● Keep your head out of fumes.</li> <li>● Use ventilation or exhaust to remove fumes from breathing zone.</li> </ul>	<ul style="list-style-type: none"> <li>● Turn power off before servicing.</li> </ul>	<ul style="list-style-type: none"> <li>● Do not operate with panel open or guards off.</li> </ul>	<b>WARNING</b>
<ul style="list-style-type: none"> <li>● Los humos fuera de la zona de respiración.</li> <li>● Mantenga la cabeza fuera de los humos. Utilice ventilación o aspiración para gases.</li> </ul>	<ul style="list-style-type: none"> <li>● Desconectar el cable de alimentación de poder de la máquina antes de iniciar cualquier servicio.</li> </ul>	<ul style="list-style-type: none"> <li>● No operar con panel abierto o guardas quitadas.</li> </ul>	Spanish <b>AVISO DE PRECAUCION</b>
<ul style="list-style-type: none"> <li>● Gardez la tête à l'écart des fumées.</li> <li>● Utilisez un ventilateur ou un aspirateur pour ôter les fumées des zones de travail.</li> </ul>	<ul style="list-style-type: none"> <li>● Débranchez le courant avant l'entretien.</li> </ul>	<ul style="list-style-type: none"> <li>● N'opérez pas avec les panneaux ouverts ou avec les dispositifs de protection enlevés.</li> </ul>	French <b>ATTENTION</b>
<ul style="list-style-type: none"> <li>● Vermeiden Sie das Einatmen von Schweißrauch!</li> <li>● Sorgen Sie für gute Be- und Entlüftung des Arbeitsplatzes!</li> </ul>	<ul style="list-style-type: none"> <li>● Strom vor Wartungsarbeiten abschalten! (Netzstrom völlig öffnen; Maschine anhalten!)</li> </ul>	<ul style="list-style-type: none"> <li>● Anlage nie ohne Schutzgehäuse oder Innenschutzverkleidung in Betrieb setzen!</li> </ul>	German <b>WARNUNG</b>
<ul style="list-style-type: none"> <li>● Mantenha seu rosto da fumaça.</li> <li>● Use ventilação e exaustão para remover fumo da zona respiratória.</li> </ul>	<ul style="list-style-type: none"> <li>● Não opere com as tampas removidas.</li> <li>● Desligue a corrente antes de fazer serviço.</li> <li>● Não toque as partes elétricas nuas.</li> </ul>	<ul style="list-style-type: none"> <li>● Mantenha-se afastado das partes moventes.</li> <li>● Não opere com os painéis abertos ou guardas removidas.</li> </ul>	Portuguese <b>ATENÇÃO</b>
<ul style="list-style-type: none"> <li>● ヒュームから頭を離すようにして下さい。</li> <li>● 換気や排煙に十分留意して下さい。</li> </ul>	<ul style="list-style-type: none"> <li>● メンテナンス・サービスに取りかかる際には、まず電源スイッチを必ず切ってください。</li> </ul>	<ul style="list-style-type: none"> <li>● パネルやカバーを取り外したままで機械操作をしないで下さい。</li> </ul>	Japanese <b>注意事項</b>
<ul style="list-style-type: none"> <li>● 頭部遠離煙霧。</li> <li>● 在呼吸區使用通風或排風器除煙。</li> </ul>	<ul style="list-style-type: none"> <li>● 維修前切斷電源。</li> </ul>	<ul style="list-style-type: none"> <li>● 儀表板打開或沒有安全罩時不準作業。</li> </ul>	Chinese <b>警告</b>
<ul style="list-style-type: none"> <li>● 얼굴로부터 용접가스를 멀리하십시오.</li> <li>● 호흡지역으로부터 용접가스를 제거하기 위해 가스제거기나 통풍기를 사용하십시오.</li> </ul>	<ul style="list-style-type: none"> <li>● 보수전에 전원을 차단하십시오.</li> </ul>	<ul style="list-style-type: none"> <li>● 관널이 열린 상태로 작동치 마십시오.</li> </ul>	Korean <b>위험</b>
<ul style="list-style-type: none"> <li>● ابعد رأسك بعيداً عن الدخان.</li> <li>● استعمل التهوية أو جهاز ضغط الدخان للخارج لكي تبعد الدخان عن المنطقة التي تتنفس فيها.</li> </ul>	<ul style="list-style-type: none"> <li>● أقطع التيار الكهربائي قبل القيام بأية صيانة.</li> </ul>	<ul style="list-style-type: none"> <li>● لا تشغيل هذا الجهاز اذا كانت الاغطية الحديدية الواقية ليست عليه.</li> </ul>	Arabic <b>تحذير</b>

**LEIA E COMPREENDA AS INSTRUÇÕES DO FABRICANTE PARA ESTE EQUIPAMENTO E AS PARTES DE USO, E SIGA AS PRÁTICAS DE SEGURANÇA DO EMPREGADOR.**

使う機械や溶材のメーカーの指示書をよく読み、まず理解して下さい。そして貴社の安全規定に従って下さい。

請詳細閱讀並理解製造廠提供的說明以及應該使用的銀焊材料，並請遵守貴方的有關勞動保護規定。

이 제품에 동봉된 작업지침서를 숙지하시고 귀사의 작업자 안전수칙을 준수하시기 바랍니다.

اقرأ بتمعن وافهم تعليمات المصنع المنتج لهذه المعدات والمواد قبل استعمالها واتبع تعليمات الوقاية لصاحب العمل.



## **CUSTOMER ASSISTANCE POLICY**

The business of Lincoln Electric is manufacturing and selling high quality welding equipment, automated welding systems, consumables, and cutting equipment. Our challenge is to meet the needs of our customers, who are experts in their fields, and to exceed their expectations. On occasion, purchasers may ask Lincoln Electric for information or technical information about their use of our products. Our employees respond to inquiries to the best of their ability based on information and specifications provided to them by the customers and the knowledge they may have concerning the application. Our employees, however, are not in a position to verify the information provided or to evaluate the engineering requirements for the particular weldment, or to provide engineering advice in relation to a specific situation or application. Accordingly, Lincoln Electric does not warrant or guarantee or assume any liability with respect to such information or communications. Moreover, the provision of such information or technical information does not create, expand, or alter any warranty on our products. Any express or implied warranty that might arise from the information or technical information, including any implied warranty of merchantability or any warranty of fitness for any customers' particular purpose or any other equivalent or similar warranty is specifically disclaimed.

Lincoln Electric is a responsive manufacturer, but the definition of specifications, and the selection and use of specific products sold by Lincoln Electric is solely within the control of, and remains the sole responsibility of the customer. Many variables beyond the control of Lincoln Electric affect the results obtained in applying these types of fabrication methods and service requirements.

## **WELD FUME CONTROL EQUIPMENT**

The operation of welding fume control equipment is affected by various factors including proper use and positioning of the equipment, maintenance of the equipment and the specific welding procedure and application involved. Worker exposure level should be checked upon installation and periodically thereafter to be certain it is within applicable OSHA PEL and ACGIH TLV limits.



### **THE LINCOLN ELECTRIC COMPANY**

22801 St. Clair Avenue • Cleveland, OH • 44117-1199 • U.S.A.  
Phone: +1.216.481.8100 • [www.lincolnelectric.com](http://www.lincolnelectric.com)