

WELDING INSTALLATION

SA TUBULAR HEAD AS

SAFETY INSTRUCTIONS FOR OPERATING AND MAINTENANCE

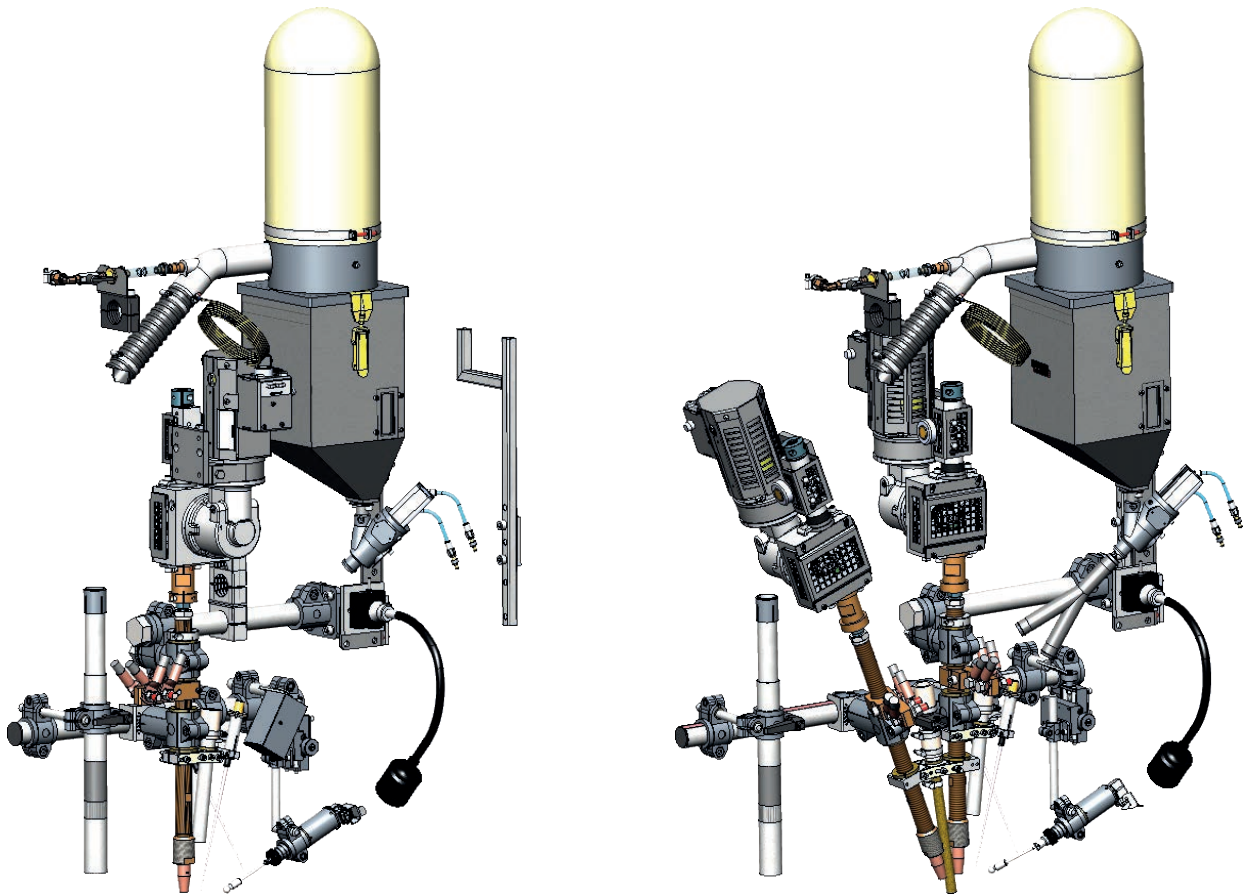

ISSUE : EN
REVISION : E
DATE : 09 - 2024

Assembly instructions

REF: 8695 5260

Original instructions

LINCOLN[®]
ELECTRIC

Thank you very much for the trust you have shown by choosing this piece of equipment. It will give you trouble-free service if it is used and maintained as recommended.

Its design, component specifications and manufacturing are in accordance with applicable European directives.

Please refer to the CE declaration enclosed to identify the directives applicable to it.

The manufacturer shall not be liable for any combination of parts not recommended by it.

For your safety, please follow the non-limitative list of recommendations and obligations, a large part of which are included in the Labour Code.

Please inform your supplier if you find any error in this instruction manual.

Table of contents

| | |
|---|----|
| A - SAFETY INSTRUCTIONS | 1 |
| 1 - Limits of use of the machine or the installation ----- | 1 |
| 2 - Residual risks ----- | 2 |
| B - DESCRIPTION | 6 |
| 1 - Single-wire/dual-wire tubular head----- | 6 |
| 2 - Single-wire/dual-wire tandem tubular head ----- | 10 |
| 3 - Heavy-duty (HD) single-wire/dual-wire tubular head----- | 14 |
| 4 - Heavy-duty (HD) single-wire/dual-wire tandem tubular head ----- | 18 |
| 5 - Single-wire internal tubular head, version 750 mm - 950 mm----- | 22 |
| 6 - Single-wire internal tandem tubular head, version 750 mm - 950 mm ----- | 24 |
| 7 - Single-wire internal tubular head, version 1100 mm ----- | 26 |
| 8 - Single-wire internal tandem tubular head, version 1100 mm----- | 28 |
| 9 - Options ----- | 30 |
| 9.1 Video option (camera) ----- | 30 |
| 9.2 Flux extraction option ----- | 31 |
| 9.3 Trackmatic tracking option ----- | 32 |
| 9.4 Laser spotlight option ----- | 33 |
| C- OPERATING MANUAL | 34 |
| 1 - Head position adjustment----- | 34 |
| 1.1 Particular precaution----- | 34 |
| 1.2 Positioning of accessories----- | 34 |
| 1.3 Circular/longitudinal positioning----- | 35 |
| 1.4 Particularity of the internal head----- | 36 |
| 1.5 Longitudinal +/- 45° positioning----- | 37 |
| 1.6 Circular +/- 45° positioning----- | 38 |
| 2 - Flux extraction position adjustment----- | 39 |
| 3 - Adjustment of heavy-duty flux supply ----- | 40 |
| D - MAINTENANCE | 41 |
| 1 - Care ----- | 41 |
| 1.1 Maintenance schedule----- | 41 |
| 2 - Spare parts ----- | 42 |
| PERSONAL NOTES | 44 |

INFORMATION

This technical literature is intended for the following machines or products:

- **Tubular head**



These instructions and the product covered by them refer to applicable standards.



Please read this document carefully before you install, use or maintain the machine. Keep this document in a safe place for future reference. This document must follow the machine described if there is a change in ownership of the machine and accompany it up to demolition.



Display and pressure gauge:

Measurement instruments or displays of voltage, intensity, speed, accuracy etc. are to be considered as indicators, whether they are analogue or digital.



For operating instructions, adjustments, troubleshooting and spare parts, please refer to the special instructions for safe operating and maintenance.



In spite of all the measures applied, invisible residual risks may still remain. Residual risks can be reduced if the safety instructions are observed, the machine is used as recommended and general service instructions are followed.

REVISIONS

REVISION : B DATE : 06/14

| DESCRIPTION | PAGE |
|-----------------------------------|-------------------|
| Addition of tubular internal head | Section B - C - D |

REVISION : C DATE : 10/14

| DESCRIPTION | PAGE |
|---|-----------|
| Addition of tubular internal head(1100mm) | Section B |

























REVISION : D DATE : 02/18

| DESCRIPTION | PAGE |
|--------------|------|
| Change logos | |

REVISION : E DATE : 09/24

| DESCRIPTION | PAGE |
|-------------|------|
| Update | |

MEANING OF SYMBOLS

| | | | |
|---|---|---|---|
|  | Reading the manual/instructions for use is mandatory. |  | Indicates a hazard. |
|  | Mandatory use of safety shoes. |  | Warning of an electricity risk or hazard. |
|  | Mandatory use of hearing protection. |  | Warning of a risk or hazard due to an obstacle on the floor. |
|  | Mandatory use of a safety helmet. |  | Warning of a risk or hazard of falling with a level change. |
|  | Mandatory use of safety gloves. |  | Warning of a risk or hazard due to suspended loads. |
|  | Mandatory use of safety glasses. |  | Warning of a risk or hazard due to a hot surface. |
|  | Mandatory use of a safety visor. |  | Warning of a risk or hazard due to moving mechanical parts. |
|  | Mandatory use of safety clothing. |  | Warning of a risk or hazard due to a closing movement of mechanical parts of a machine. |
|  | Make sure you clean the working zone. |  | Warning of a risk or hazard due to laser radiation. |
|  | Mandatory use of breathing protection. |  | Warning of a risk or hazard due to an obstacle at a height. |
|  | Visual inspection required. |  | Warning of a risk or hazard due to the presence of a pointed part. |
|  | Indicates a lubrication operation. |  | Wearers of pacemakers may not be admitted in the designated area. |
|  | Requires maintenance action. | | |



For general safety instructions, please refer to the specific manual supplied with the equipment.

1 - Limits of use of the machine or the installation



The limits of use of the machine (or installation) are provided in the different documents; please review them carefully before starting to use the machine (or installation).

For safety reasons, and in the light of our current knowledge of customer processes, the working area may be occupied only by one individual.

The machine (or installation) may only be operated by a single person above the age of 18 and trained in operating and use-related risks.

The machine (or installation) may only be used for welding applications; any other use of the machine is forbidden.

The machine (or installation) is designed for indoor use.

It may not be used outdoors.

The workshop must be adequately lit and ventilated.

Loading and unloading may only be carried out outside the welding cycle.

The energy supply must imperatively comply with recommendations.

The customer must supply and install a device for isolating each source of energy (electricity, air, gas and water). The devices must be clearly identified. They must be of the locking type.

The machine (or installation) is designed for professional use.

Before use, the operator must make sure that there is no risk of collision with personnel.

The use of Personal Protective Equipment (PPE) and work clothing covering the body is mandatory in the work area. Do not wear a tie and keep your hair tied back securely.



Make sure that no part of the machine can come within less than 500 mm from an obstacle.

Important: the operator passage way must absolutely be clear over a minimum width of 800 mm.

The floor should be marked out.

While accessing the marked area, a worker could be hit by a part of the installation.

For any extended absence, the operator must shut off the supply of utilities (electricity and fluids).

Maintenance may only be carried out by experienced personnel who are trained in machine-related risks.

Machine maintenance must be carried out with all the energy supplies switched off.

The disconnection and padlocking of all energy sources is mandatory.

Access to the machine (or installation) must be left free for maintenance (e.g. no workpiece etc.).

The frequency of such maintenance is indicated for production in one work shift per day (i.e. 8 hours a day).

Visually inspect the overall condition of the installation and the working area twice a shift, or with every change of production.

The maintenance schedule must absolutely be followed.

We recommend putting in place a traced system for tracking all your maintenance operations.

All maintenance must be carried out by specialised personnel who have read and understood these instructions.

Electricity technician

Qualified operator with the ability to work in normal conditions on electrical parts for regulation, maintenance and repair.

Mechanical technician

Specialised technician authorised to carry out complex and exceptional mechanical operations.

Do not drop loads on the equipment.

Make sure that the working of the equipment is not hindered by tools and/or objects left close to the rotating part or by its appendages, which could strike fixed elements (ground, frame, posts).

Make sure that the power and control conductors of the machine are in good condition.

Before using the machine. Make sure that the guard covers of the electrical and mechanical parts are in place before starting up the equipment.

All guard covers must be screwed in.

Clean the working area from time to time.

Never modify the machine.

The tubular head is not designed for anchoring handling equipment.

Never remove the insulation plates under the head and motor supports.

CAUTION: At the end of a reel, the wire may be thrown out of the reel suddenly (whip effect).

If the reel changed is not empty, the wire may be paid out.

- **MIND the weight of the reel**
- **Put the reel shaft arms back in place after the work**

2 - Residual risks

Based on the results of the risk assessment, a few elements have emerged where there was no “technical” solution for eliminating risk or making it negligible.

In spite of all the care that has gone into the designing of our machines (or installations), some risk areas remain. To control these risks, the customer must pay particular attention to them, ensure that the instructions are applied and define any additional measures that may be necessary in view of its own internal operating procedures.

Therefore, you will find below a guidance list of residual risks.

Training of operators in safety and in the use of the machine from their operating position will better address these residual risks.

We recommend putting place workstation instructions that remind users of the presence or otherwise of residual risks in the working area.

2.1 - Residual risks - General

☛ Environment risk - slipping and/or falling



The working and safety area must be clear of all obstacles.

The working area must be kept clean and cleaned regularly.

The machine must undergo periodic maintenance (see maintenance instructions of each piece of equipment).

Waste consumables must be cleaned.

The operator must pay special attention to cables and rolling tracks on the ground.

The operator must use the necessary personal protective equipment (helmet, gloves, safety shoes, mask and work clothing).

Falling from heights:

In order to be protected from falling from heights and for access to high parts, the operator must use access means that comply with applicable standards.

For all work at heights, the use of personal protective equipment (helmet, gloves, safety shoes, mask, ear muffs and harness) is indispensable.

For all work at heights, the operator must be trained in the use of means for accessing high locations.

☛ Mechanical risk - Impacts, shearing, crushing



The operator may not wear loose clothing or a tie, must have their hair tied back and use personal protective equipment (helmet, gloves, safety shoes, mask and work clothing).

The operator must make sure that nobody else is close to the machine before starting.

The operator's working position is before the control console.

The machine safety areas must not be crossed.

The operator must be trained in the use of the machine, and all personnel must be aware of residual risks.

Catching between an obstacle and the machine - Access to a moving part.

The operator must use personal protective equipment, (helmet, gloves, safety shoes, mask and work clothing).

The operator's working position is before the control console.

The operator must make sure nobody is present in the machine working area or safety area before using it.

The operator must make sure that all the machine guards are in place before using it.

The operator must be trained in the use of the machine, and all personnel must be aware of residual risks.

Anchoring failure of handling equipment

The machine may not be modified.

The machine is not designed for anchoring lifting equipment.

Any change in the machine location must be made by **Lincoln Electric** or authorised personnel.

Presence of a person under the load

The operator must be trained and approved for the use of handling equipment.

The operator must be trained in the use of the machine, and all personnel must be aware of residual risks.

☛ **Mechanical risk - Puncturing or piercing**



The use of personal protective equipment (helmet, gloves, safety shoes, mask, ear muffs) is indispensable.

The operator must be trained in the use of the machine and all personnel must be aware of residual risks.

☛ **Thermal risk - Burns**



Part of the body in contact with a hot part (torch/workpiece etc.)

The use of personal protective equipment (helmet, gloves, safety shoes, mask, ear muffs) is indispensable.

The operator must be trained in the use of the machine and all personnel must be aware of residual risks.

☛ **Noise risk - Fatigue**



Process noise

The use of personal protective equipment (helmet, gloves, safety shoes, mask, ear muffs) is indispensable.

The operator must be trained in the use of the machine and all personnel must be aware of residual risks.

2.2 - Residual risks - Process

☛ **Electrical risk - Splattering of molten particles**



Splattering of molten material on flammable materials or personnel:

The working area must be kept clean and cleaned regularly.

Put guards in place around the torches depending on the working environment.

The use of personal protective equipment (helmet, gloves, safety shoes, mask, ear muffs, fire-resistant work clothing) is indispensable.

The operator must be trained in the use of the machine, and all personnel must be aware of residual risks.

☛ **Ergonomics risk - Fatigue**

Loading of heavy coils on coil carriers at a height:

The operator must use appropriate handling means.

The operator must be trained in the use of the machine, and all personnel must be aware of residual risks.

☛ **Material and product risks - Poisoning**



Fumes/gas discharged by the process:

Provide for the use of extraction equipment (to be supplied by the customer).

The use of personal protective equipment (helmet, gloves, safety shoes, mask, ear muffs) is indispensable.

The operator must be trained in the use of the machine, and all personnel must be aware of residual risks.

☛ **Mechanical risk - Puncturing or piercing**



Contact between the end of the filler wire and a part of the body

The use of personal protective equipment (helmet, gloves, safety shoes, mask, ear muffs) is indispensable.

The operator must be trained in the use of the machine and all personnel must be aware of residual risks.

☛ **Radiation risk - Eye and skin injuries**



Arc flash

Put guards in place around the torches depending on the working environment.

The use of personal protective equipment (helmet, gloves, safety shoes, mask, ear muffs) is indispensable.

The operator must be trained in the use of the machine and all personnel must be aware of residual risks.

☛ **Thermal risk - Burns**



Part of the body in contact with a hot part (torch/workpiece etc.)

The use of personal protective equipment (helmet, gloves, safety shoes, mask, ear muffs) is indispensable.

The operator must be trained in the use of the machine and all personnel must be aware of residual risks.

Welded parts can remain hot for a certain length of time.

☛ **Noise risk - Fatigue**





Process noise

The use of personal protective equipment (helmet, gloves, safety shoes, mask, ear muffs) is indispensable.

The operator must be trained in the use of the machine and all personnel must be aware of residual risks.

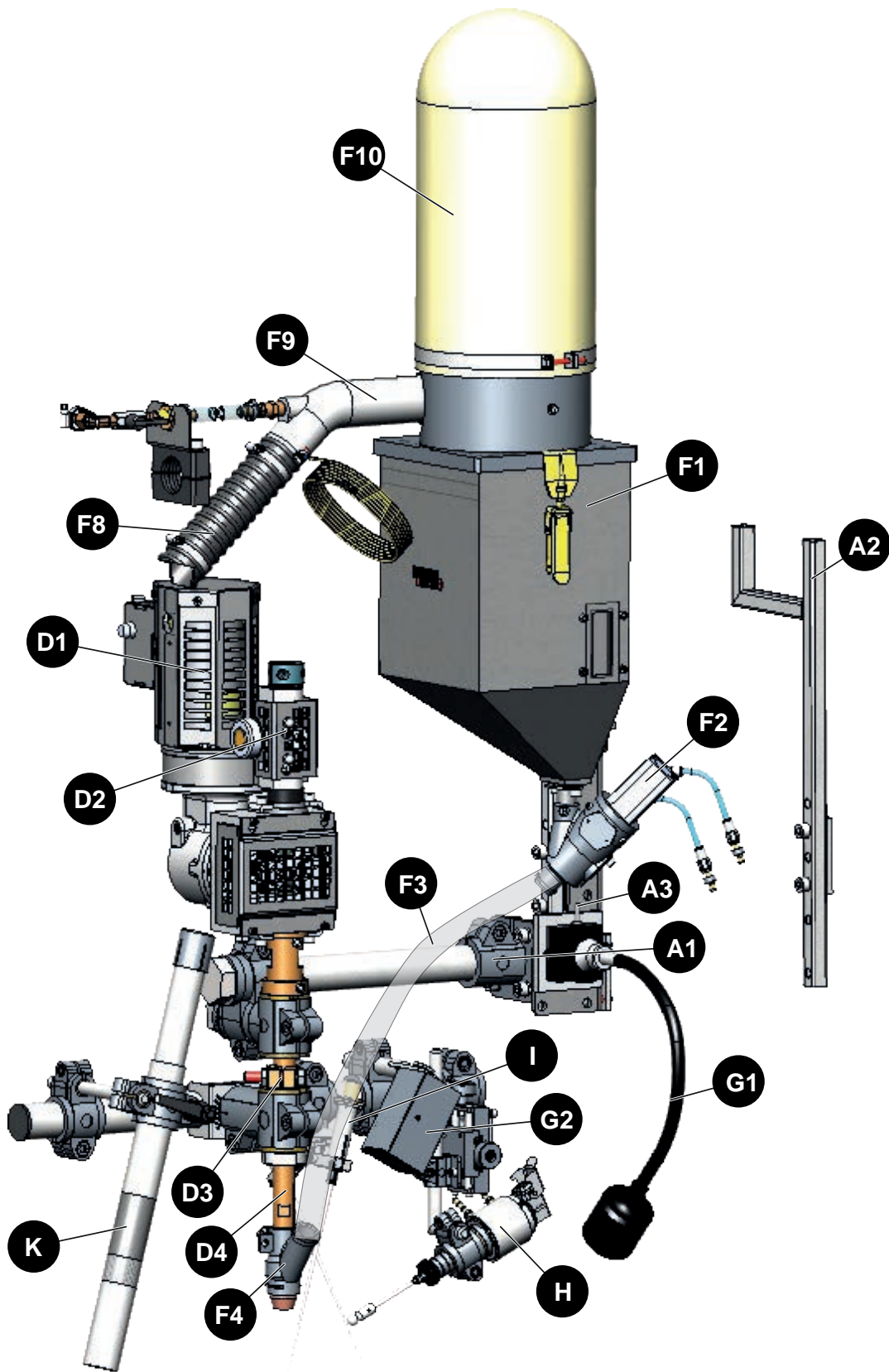
1 - Single-wire/dual-wire tubular head



| Reference | Description | |  |
|---|------------------------|---|---|
| ☛ Fastening the welding head assembly to the machine | | | |
| A | A1 | Fastening to machines | |
| | A2 | Machine connection cable and bundle support | |
| | A3 | Flux tank support | |
| ☛ Details of feed components | | | |
| D | D1 | MAxSA feed assembly | IM10024 |
| | D2 | Wire straightener | 86955239 |
| | D3 | Current feed | |
| | D4 | Wire feed | |
| ☛ Details of flux recycling and distribution components | | | |
| F | F1 | Flux container | 86955245 |
| | F2 | Automatic flux supply valve | |
| | F3 | SA pipe, diameter =25x35 mm | |
| | F4 | Large concentric flux supply | |
| | F8 | Pipe, diameter 40mm | |
| | F9 | Venturi extraction body | |
| | F10 | Fabric sleeve or cover | |
| ☛ Details of optional components | | | |
| G | G1 | Lamp | 86955896 |
| | G2 | Camera | |
| H | Sensing pin | 86956863 | |
| I | Laser spotlight | 86955891 | |
| K | Flux extraction sensor | 86955245 | |

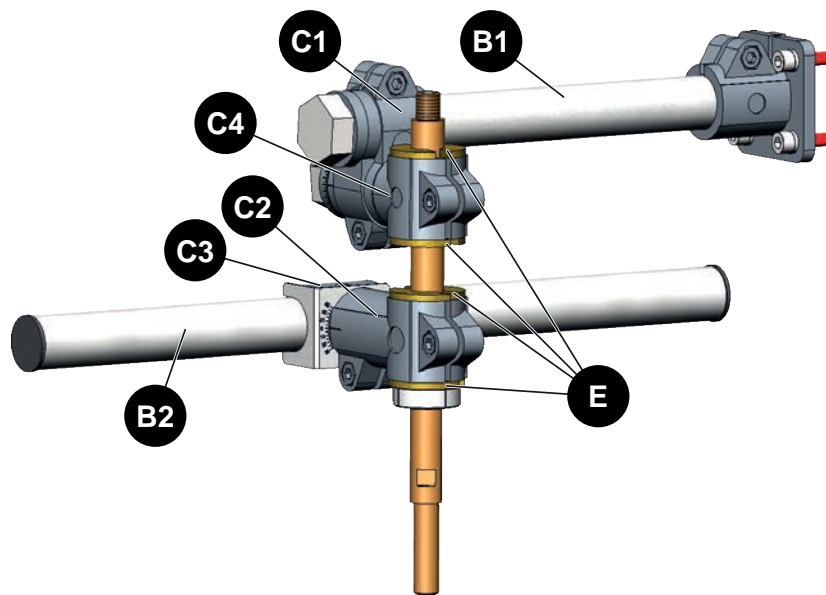

| Reference | Description | |  |
|---|------------------|----------------------------------|---|
| ☛ Single-wire/dual-wire tubular head base | | | |
| B | B1 | Tube Ø40 - 357 mm - M30 | |
| | B2 | Stainless steel tube Ø40 | |
| C | C1 | Female/female connector, 40 x 40 | |
| | C2 | Female connector, 40 | |
| | C3 | Male connector, 40 | |
| | C4 | Male connector, 30 | |
| E | Insulating rings | | |

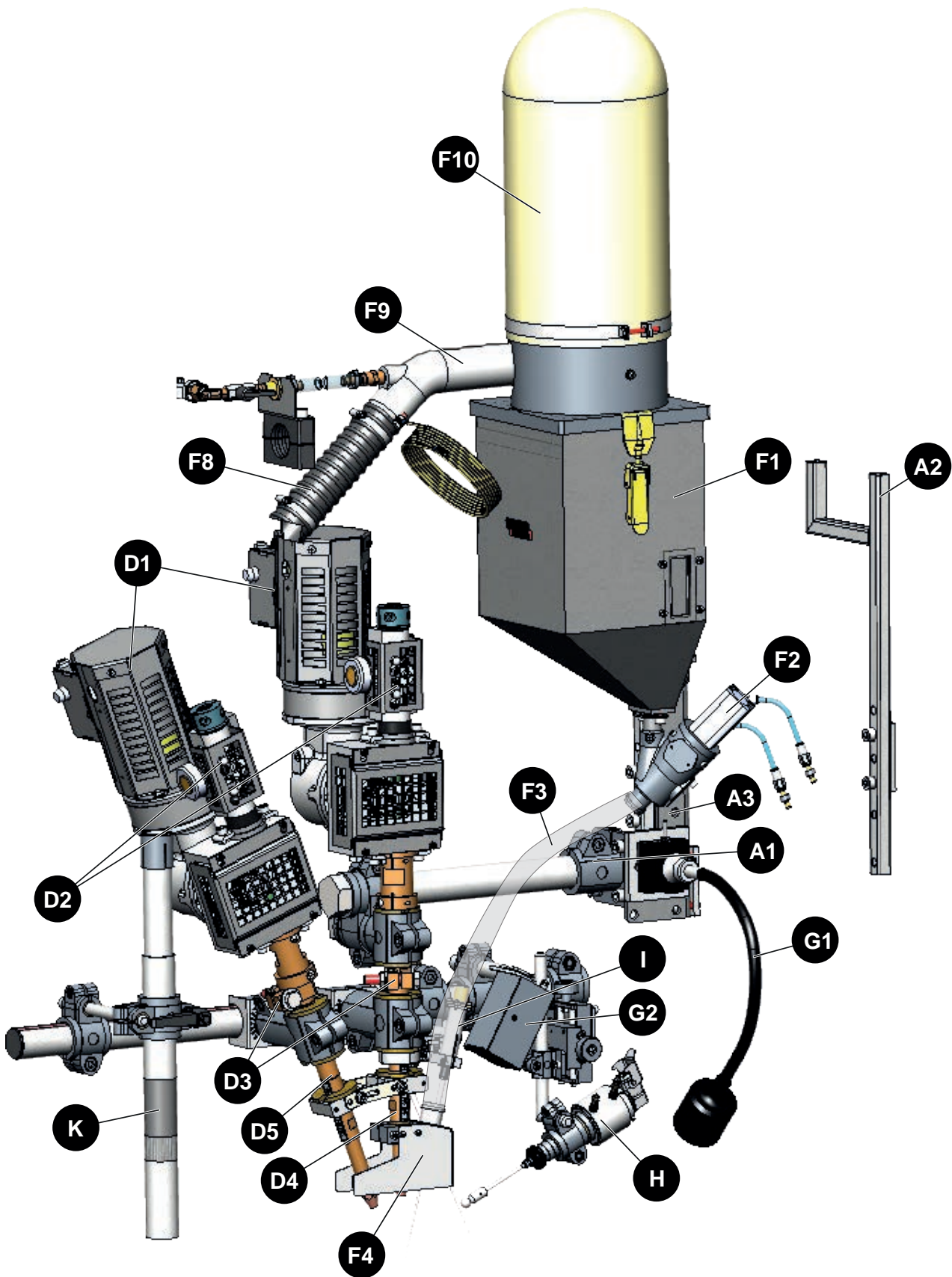

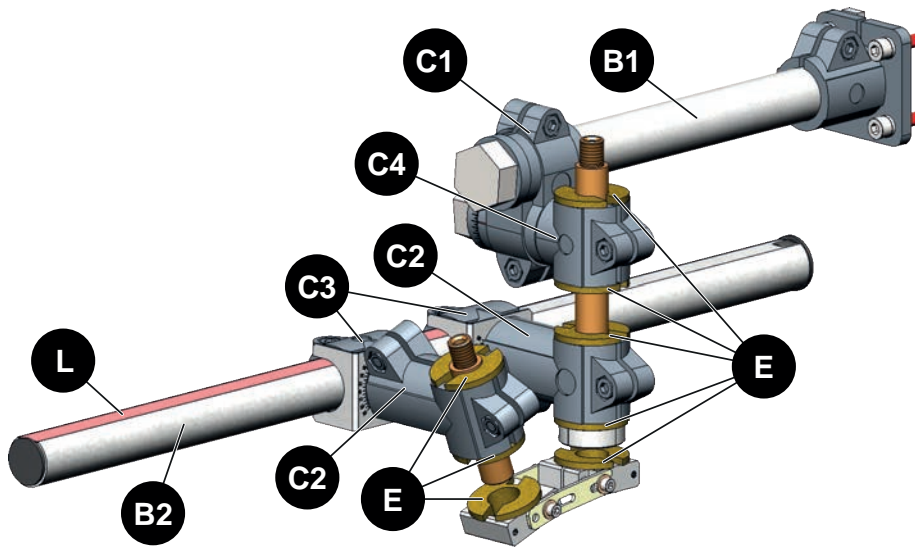

| Reference | Description | |  |
|---|------------------------|---|---|
| ☛ Fastening the welding head assembly to the machine | | | |
| A | A1 | Fastening to machines | |
| | A2 | Machine connection cable and bundle support | |
| | A3 | Flux tank support | |
| ☛ Details of feed components | | | |
| D | D1 | MAxSA feed assembly | IM10024 |
| | D2 | Wire straightener | 86955239 |
| | D3 | Current feed | |
| | D4 | Wire 1 supply (DC) | |
| | D5 | Wire 2 supply (AC) | |
| ☛ Details of flux recycling and distribution components | | | |
| F | F1 | Flux container | 86955245 |
| | F2 | Automatic flux supply valve | |
| | F3 | SA pipe, diameter =25x35 mm | |
| | F4 | Small or large concentric flux supply | |
| | F8 | Pipe, diameter 40mm | |
| | F9 | Venturi extraction body | |
| | F10 | Fabric sleeve or cover | |
| ☛ Details of optional components | | | |
| G | G1 | Lamp | 86955896 |
| | G2 | Camera | |
| H | Sensing pin | | 86956863 |
| I | Laser spotlight | | 86955891 |
| K | Flux extraction sensor | | 86955245 |



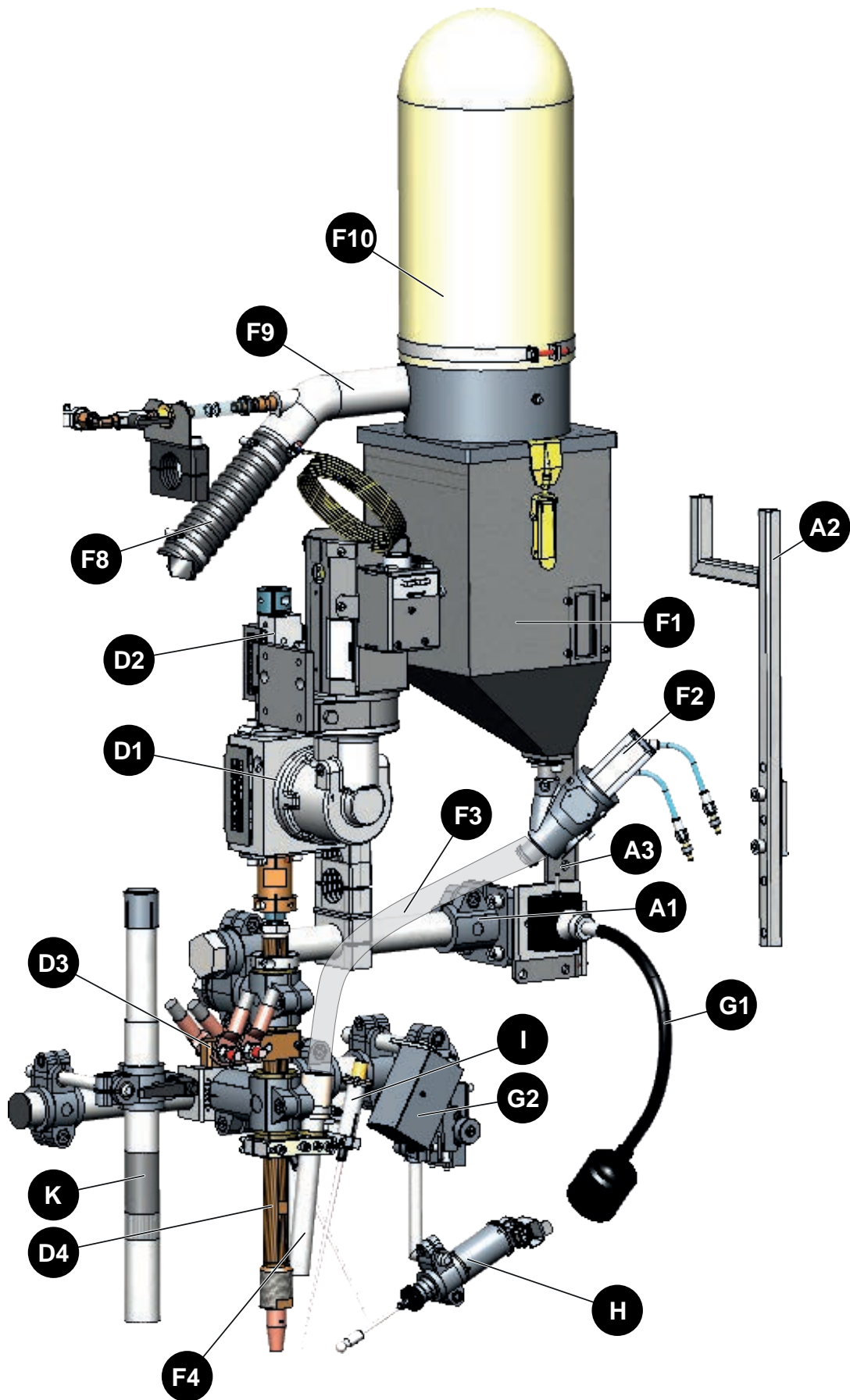

| Reference | Description | |  |
|--|------------------|----------------------------------|---|
| 👉 Single-wire/dual-wire tandem tubular head base | | | |
| B | B1 | Tube Ø40 - 357 mm - M30 | |
| | B2 | Adjustment tube, Ø40 | |
| C | C1 | Female/female connector, 40 x 40 | |
| | C2 | Female connector, 40 | |
| | C3 | Male connector, 40 | |
| | C4 | Male connector, 30 | |
| E | Insulating rings | | |
| L | Graduated rule | | |

3 - Heavy-duty (HD) single-wire/dual-wire tubular head



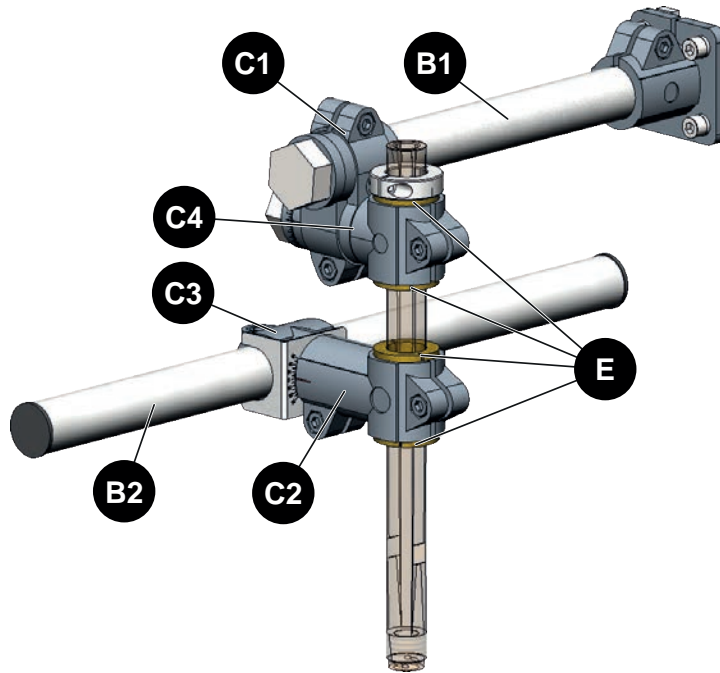

| Reference | Description | |  |
|---|------------------------|---|---|
| ☛ Fastening the welding head assembly to the machine | | | |
| A | A1 | Fastening to machines | |
| | A2 | Machine connection cable and bundle support | |
| | A3 | Flux tank support | |
| ☛ Details of feed components | | | |
| D | D1 | MAxSA feed assembly | IM10024 |
| | D2 | Wire straightener | 86955239 |
| | D3 | Current feed | |
| | D4 | Wire feed | |
| ☛ Details of flux recycling and distribution components | | | |
| F | F1 | Flux container | 86955245 |
| | F2 | Automatic flux supply valve | |
| | F3 | SA pipe, diameter =25x35 mm | |
| | F4 | Small or large concentric flux supply | |
| | F8 | Pipe, diameter 40mm | |
| | F9 | Venturi extraction body | |
| | F10 | Fabric sleeve or cover | |
| ☛ Details of optional components | | | |
| G | G1 | Lamp | 86955896 |
| | G2 | Camera | |
| H | Sensing pin | 86956863 | |
| I | Laser spotlight | 86955891 | |
| K | Flux extraction sensor | 86955245 | |



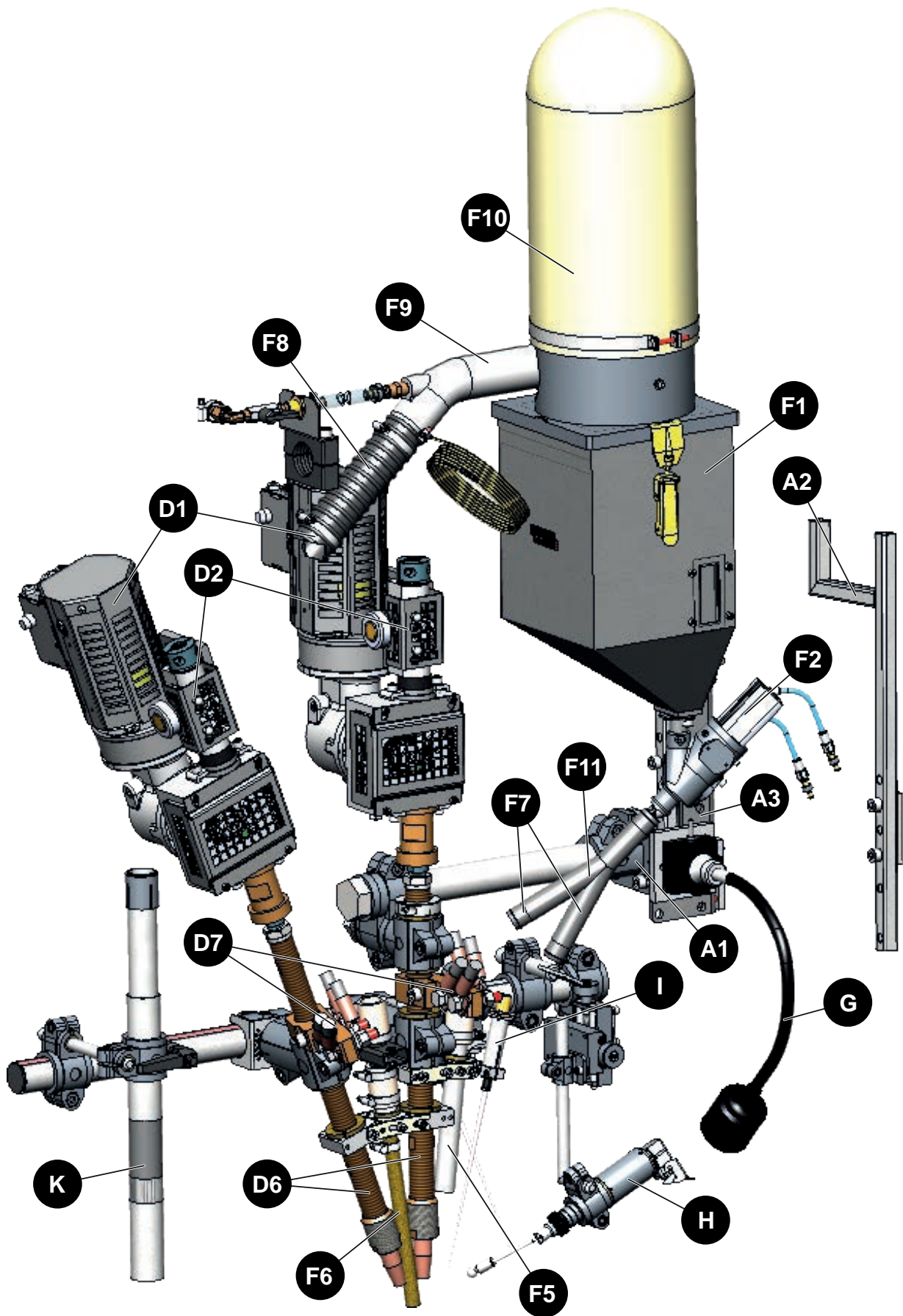

| Reference | Description | |  |
|---|------------------|----------------------------------|---|
| ☛ Single-wire/dual-wire tubular head base | | | |
| B | B1 | Tube Ø40 - 357 mm - M30 | |
| | B2 | Stainless steel tube Ø40 | |
| C | C1 | Female/female connector, 40 x 40 | |
| | C2 | Female connector, 40 | |
| | C3 | Male connector, 40 | |
| | C4 | Male connector, 30 | |
| E | Insulating rings | | |

4 - Heavy-duty (HD) single-wire/dual-wire tandem tubular head

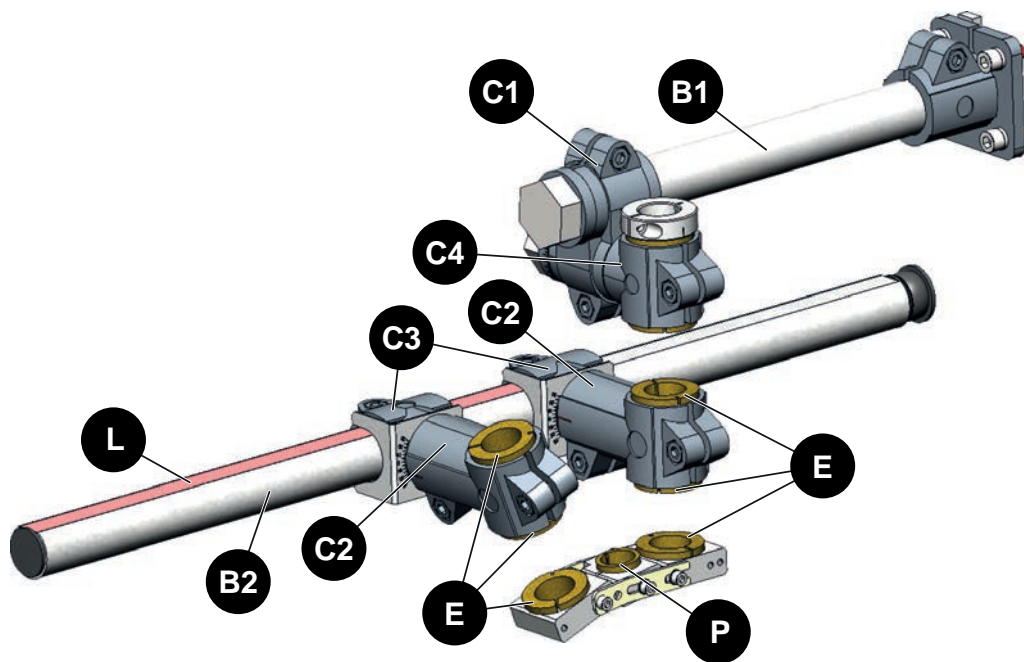

| Reference | Description | |  |
|--|------------------------|---|---|
| ☛ Fastening the welding head assembly to the machine | | | |
| A | A1 | Fastening to machines | |
| | A2 | Machine connection cable and bundle support | |
| | A3 | Flux tank support | |
| ☛ Details of feed components | | | |
| D | D1 | MAxSA feed assembly | IM10024 |
| | D2 | Wire straightener | 86955239 |
| | D6 | Wire feed | |
| | D7 | Current feed | |
| ☛ Details of specific distribution components | | | |
| F | F5 | Main flux supply | 86955245 |
| | F6 | Secondary flux supply | |
| | F7 | SA pipe | |
| | F11 | Y bypass | |
| ☛ Details of specific distribution components | | | |
| F | F1 | Flux container | 86955245 |
| | F2 | Automatic flux supply valve | |
| | F8 | Pipe, diameter 40mm | |
| | F9 | Venturi extraction body | |
| | F10 | Fabric sleeve or cover | |
| ☛ Details of optional components | | | |
| G | Lamp | | 86955896 |
| | Camera (not shown) | | |
| H | Sensing pin | | 86956863 |
| I | Laser spotlight | | 86955891 |
| K | Flux extraction sensor | | 86955245 |





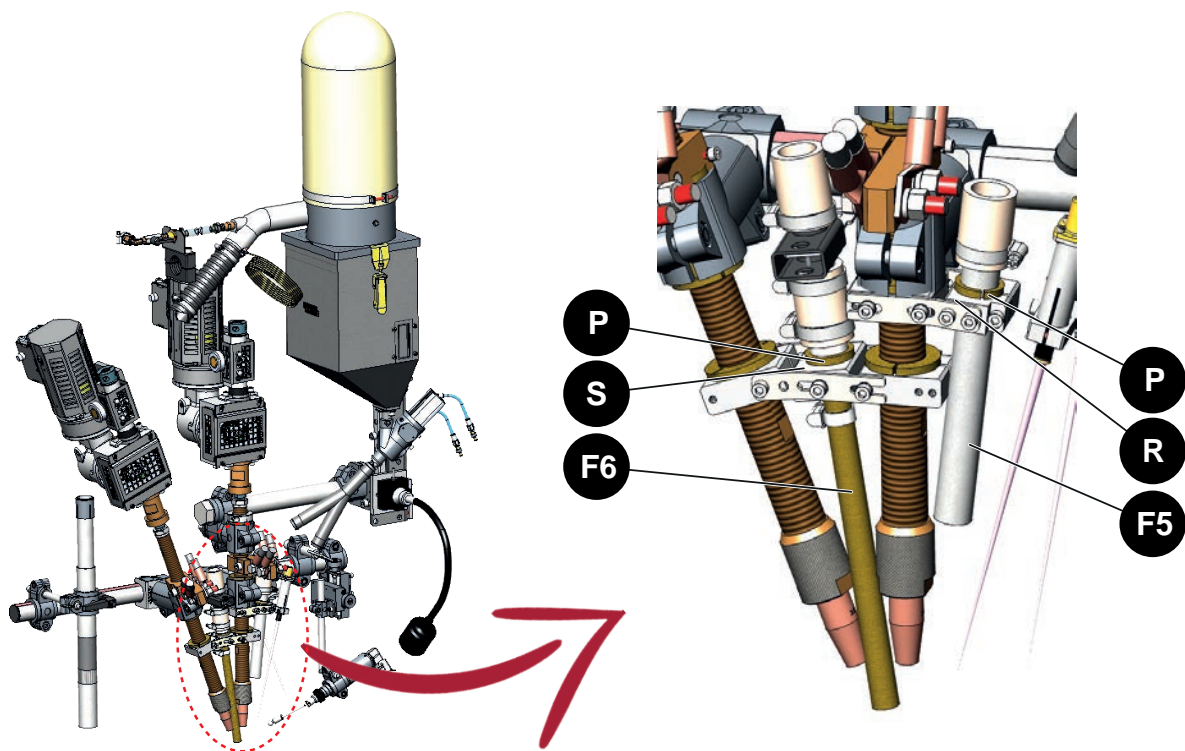

| Reference | Description | |  |
|---|------------------|----------------------------------|---|
|  Heavy-duty (HD) single-wire/dual-wire tubular head base | | | |
| B | B1 | Tube Ø40 - 357 mm - M30 | |
| | B2 | Stainless steel tube Ø40 | |
| C | C1 | Female/female connector, 40 x 40 | |
| | C2 | Female connector, 40 | |
| | C3 | Male connector, 40 | |
| | C4 | Male connector, 30 | |
| E | Insulating rings | | |
| P | Insulating rings | | |
| L | Graduated rule | | |

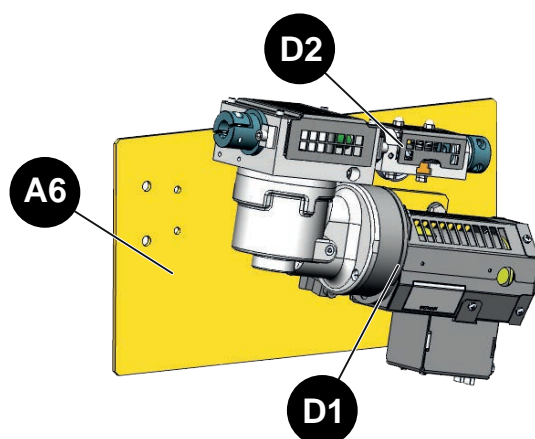
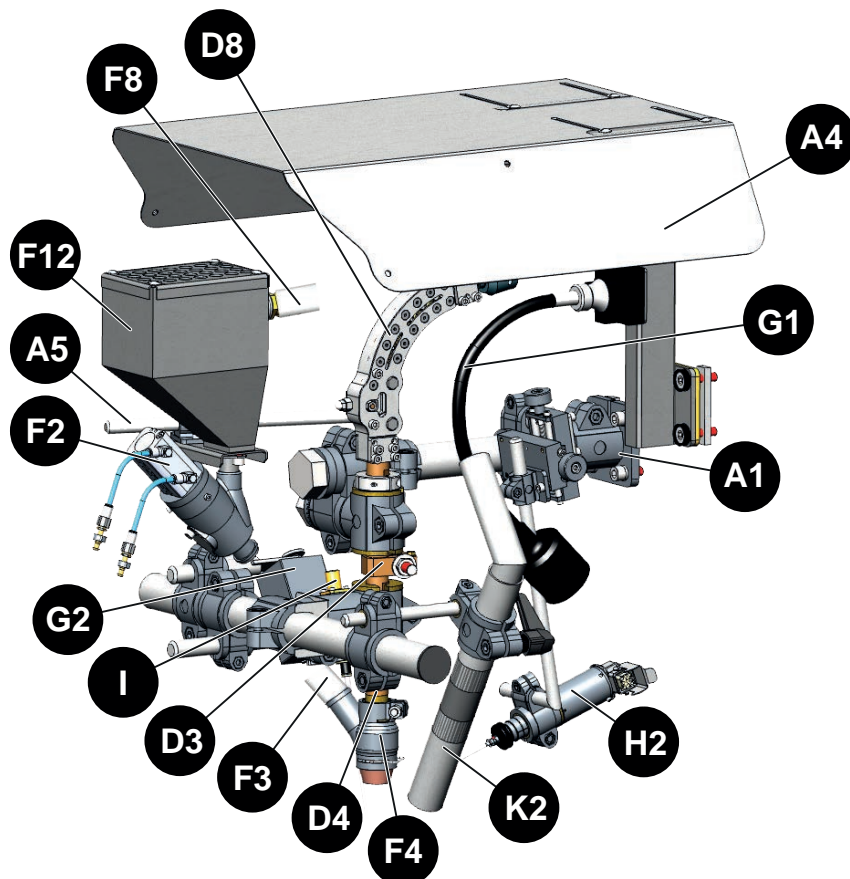

| Reference | Description |  |
|-------------------------|--|---|
| ☛ Main flux supply | | |
| F5 | Main flux supply | |
| P | Insulating ring for main flux supply | |
| R | Main flux supply support | |
| ☛ Secondary flux supply | | |
| F6 | Secondary flux supply with manual flux valve | |
| P | Insulating ring for secondary flux supply | |
| S | Secondary flux supply support | |







| Reference | Description | |  |
|---|-------------|------------------------------------|---|
|  Fastening the welding head assembly to the machine | | | |
| A | A1 | Fastening to machines | |
| | A4 | Cable support and protective cover | |
| | A5 | Flux tank support | |
| | A6 | MAxSA wire feed support | |
|  Details of feed components | | | |
| D | D1 | MAxSA feed assembly | IM10024 |
| | D2 | Wire straightener | 86955239 |
| | D3 | Current feed | |
| | D4 | Wire feed | |
| | D8 | Single-wire curved feed | |
|  Details of flux recycling and distribution components | | | |
| F | F2 | Automatic flux supply valve | 86955245 |
| | F3 | Submerged Arc (SA) pipe, Ø25*35 mm | |
| | F4 | Large concentric flux supply | |
| | F8 | Pipe, diameter 40mm | |
| | F12 | Flux container | |
|  Details of optional components | | | |
| | G1 | Lamp | 86955896 |
| | G2 | Camera | |
| | H2 | Sensing pin | 86956863 |
| | I | Laser spotlight | 86955891 |
| | K2 | Flux extraction sensor | 86955245 |

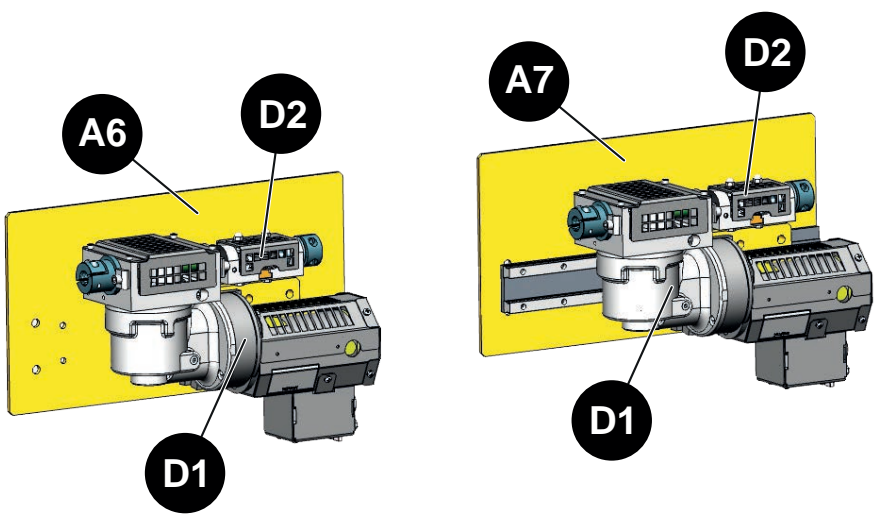
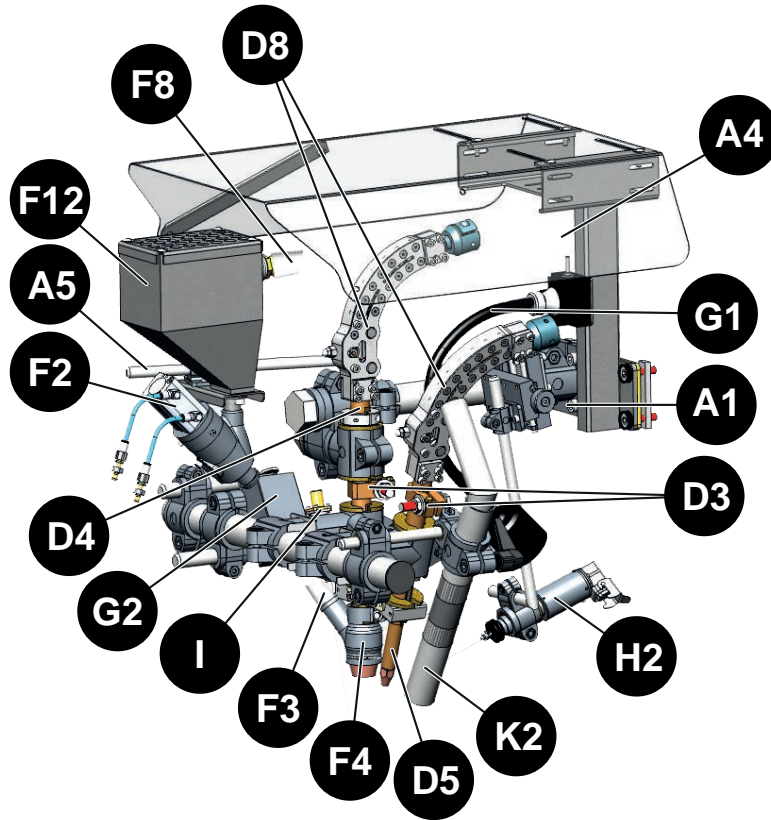

For the base, refer to the single/dual-wire tubular head installation composition.







| Reference | Description | |  |
|---|-------------|------------------------------------|---|
|  Fastening the welding head assembly to the machine | | | |
| A | A1 | Fastening to machines | |
| | A4 | Cable support and protective cover | |
| | A5 | Flux tank support | |
| | A6 | MAxSA feed support, torch 1 | |
| | A7 | MAxSA feed support, torch 2 | |
|  Details of feed components | | | |
| D | D1 | MAxSA feed assembly | IM10024 |
| | D2 | Wire straightener | 86955239 |
| | D3 | Current feed | |
| | D4 | Wire 1 supply (DC) | |
| | D5 | Wire 2 supply (AC) | |
| | D8 | Single-wire curved feed | |
|  Details of flux recycling and distribution components | | | |
| F | F2 | Automatic flux supply valve | 86955245 |
| | F3 | Submerged Arc (SA) pipe, Ø25*35 mm | |
| | F4 | Large concentric flux supply | |
| | F8 | Pipe, diameter 40mm | |
| | F12 | Flux container | |
|  Details of optional components | | | |
| | G1 | Lamp | 86955896 |
| | G2 | Camera | |
| | H2 | Sensing pin | 86956863 |
| | I | Laser spotlight | 86955891 |
| | K2 | Flux extraction sensor | 86955245 |

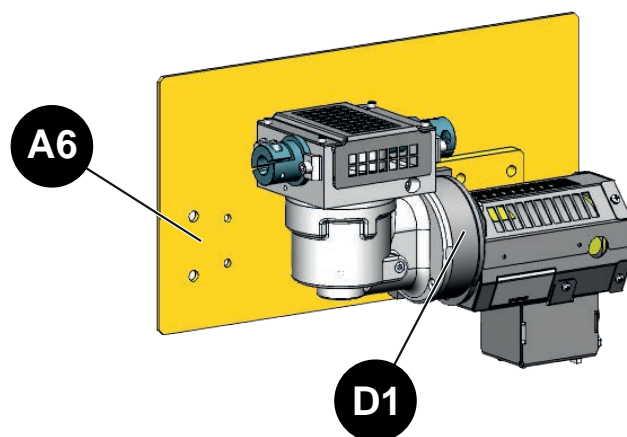
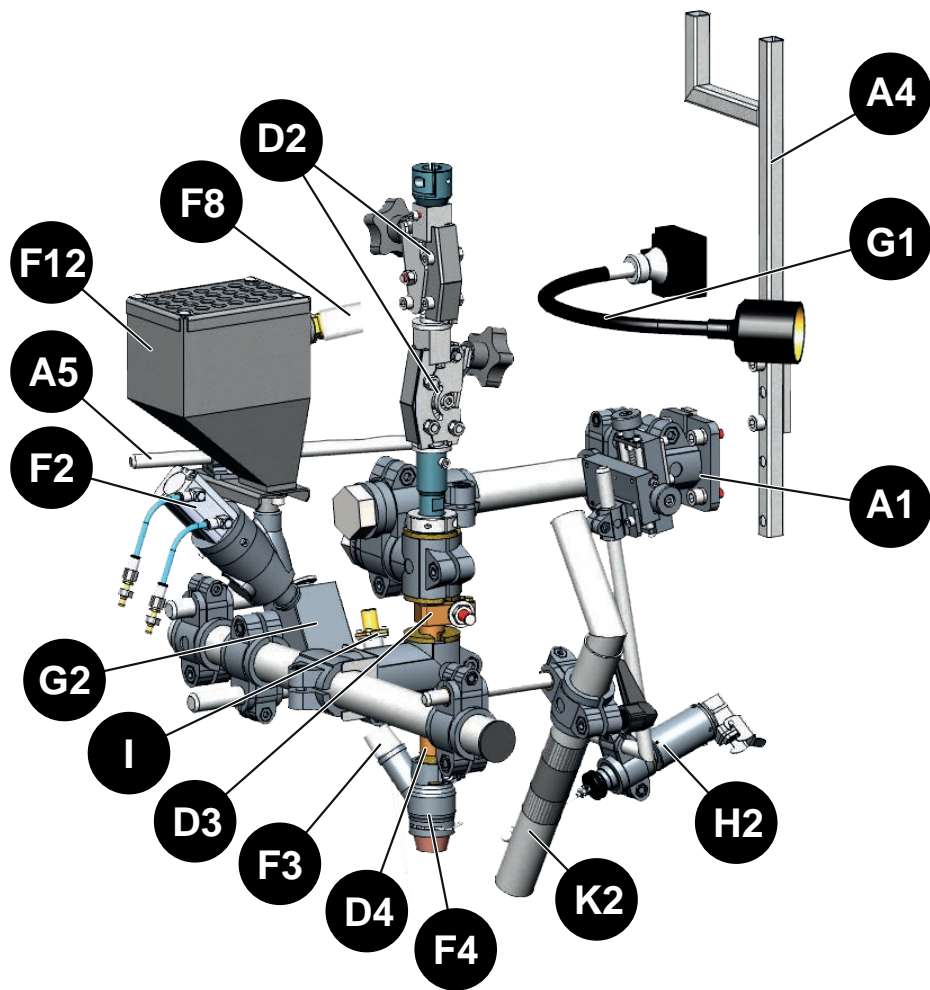

For the base, refer to the tandem tubular head installation composition.







| Reference | Description | |  |
|---|-------------|------------------------------------|---|
|  Fastening the welding head assembly to the machine | | | |
| A | A1 | Fastening to machines | |
| | A4 | Cable support | |
| | A5 | Flux tank support | |
| | A6 | MAxSA wire feed support | |
|  Details of feed components | | | |
| D | D1 | MAxSA feed assembly | IM10024 |
| | D2 | Wire straightener | 86955239 |
| | D3 | Current feed | |
| | D4 | Wire feed | |
|  Details of flux recycling and distribution components | | | |
| F | F2 | Automatic flux supply valve | 86955245 |
| | F3 | Submerged Arc (SA) pipe, Ø25*35 mm | |
| | F4 | Large concentric flux supply | |
| | F8 | Pipe, diameter 40mm | |
| | F12 | Flux container | |
|  Details of optional components | | | |
| | G1 | Lamp | 86955896 |
| | G2 | Camera | |
| | H2 | Sensing pin | 86956863 |
| | I | Laser spotlight | 86955891 |
| | K2 | Flux extraction sensor | 86955245 |

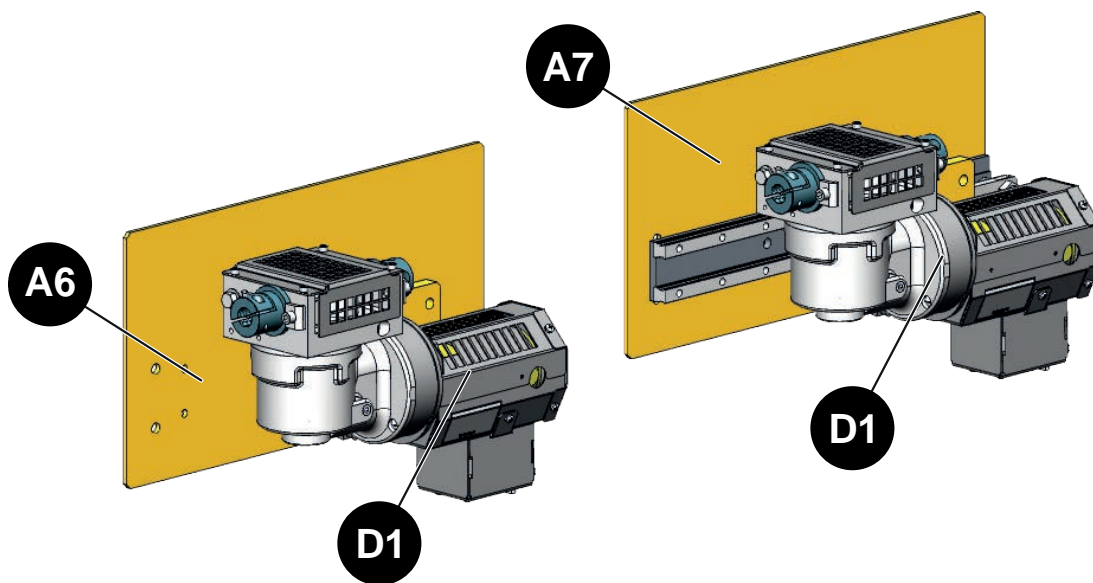
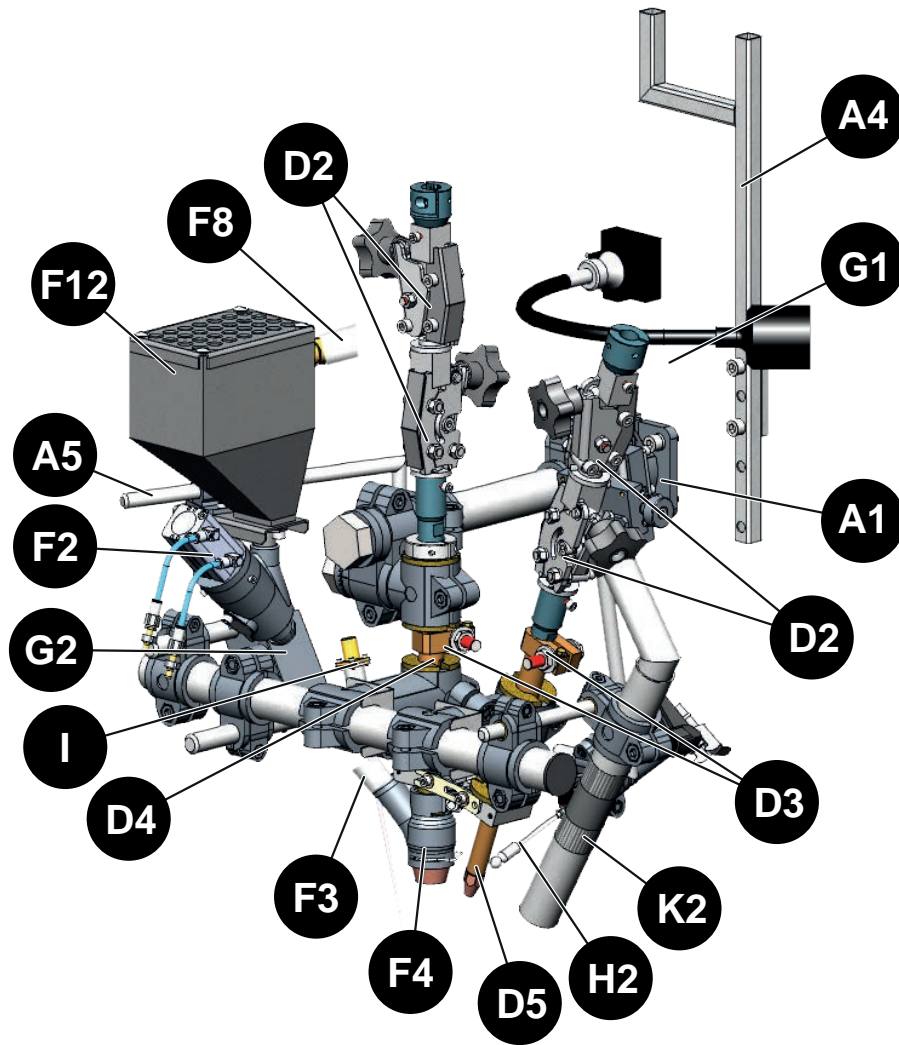

For the base, refer to the single/dual-wire tubular head installation composition.





| Reference | Description | |  |
|---|-------------|------------------------------------|---|
|  Fastening the welding head assembly to the machine | | | |
| A | A1 | Fastening to machines | |
| | A4 | Cable support | |
| | A5 | Flux tank support | |
| | A6 | MAxSA feed support, torch 1 | |
| | A7 | MAxSA feed support, torch 2 | |
|  Details of feed components | | | |
| D | D1 | MAxSA feed assembly | IM10024 |
| | D2 | Wire straightener | 86955239 |
| | D3 | Current feed | |
| | D4 | Wire 1 supply (DC) | |
| | D5 | Wire 2 supply (AC) | |
|  Details of flux recycling and distribution components | | | |
| F | F2 | Automatic flux supply valve | 86955245 |
| | F3 | Submerged Arc (SA) pipe, Ø25*35 mm | |
| | F4 | Large concentric flux supply | |
| | F8 | Pipe, diameter 40mm | |
| | F12 | Flux container | |
|  Details of optional components | | | |
| | G1 | Lamp | 86955896 |
| | G2 | Camera | |
| | H2 | Sensing pin | 86956863 |
| | I | Laser spotlight | 86955891 |
| | K2 | Flux extraction sensor | 86955245 |



For the base, refer to the tandem tubular head installation composition.

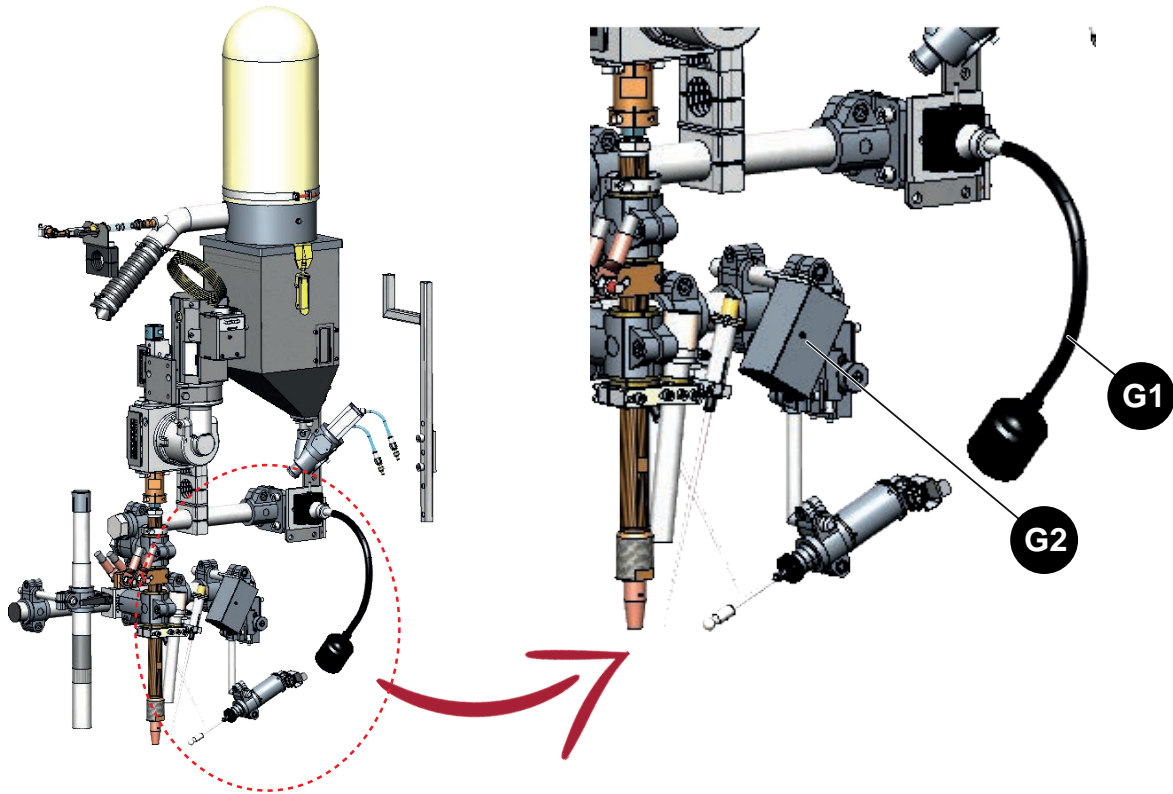

9.1 Video option (camera)

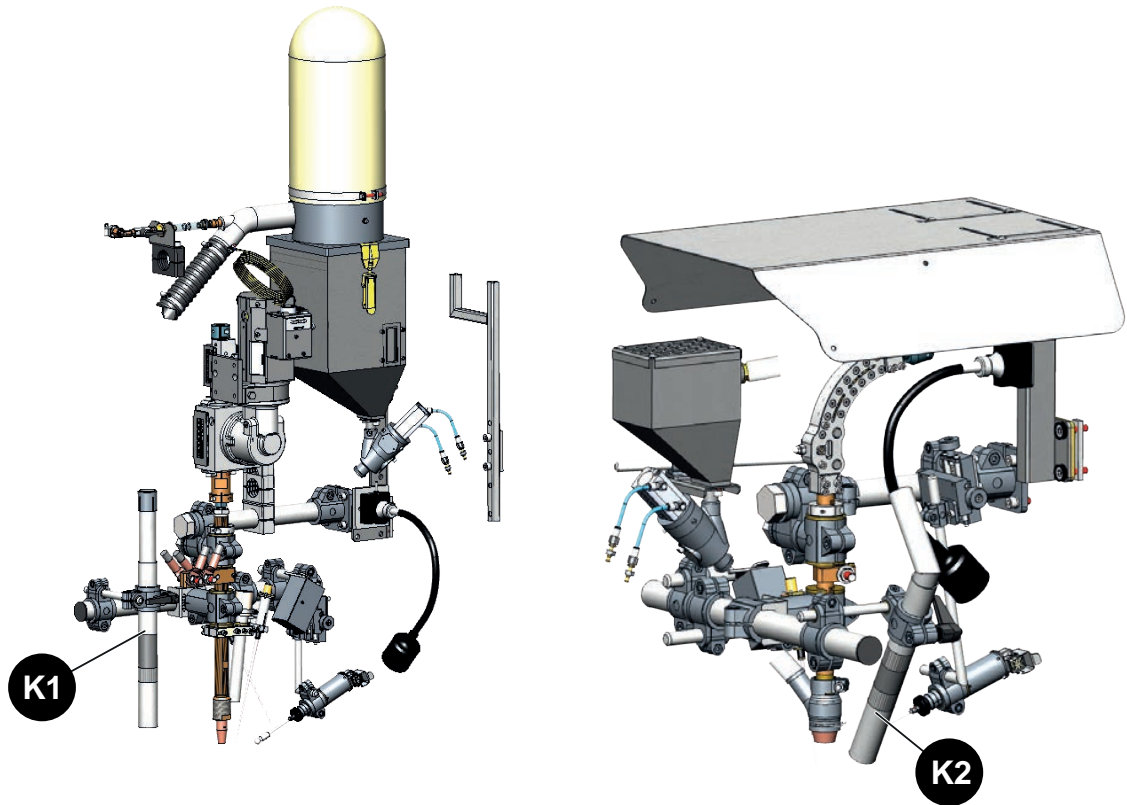

| Reference | Description | |  |
|-----------|---|--------|---|
| |  Video option base | | |
| G | G1 | Lamp | 86955896 |
| | G2 | Camera | |

9.2 Flux extraction option



| Reference | Description | |  |
|---|-------------|---|---|
|  Flux extraction option base | | | |
| K | K1 | Flux extraction sensor assembly | 86955245 |
| | K2 | Internal head flux extraction sensor assembly | |

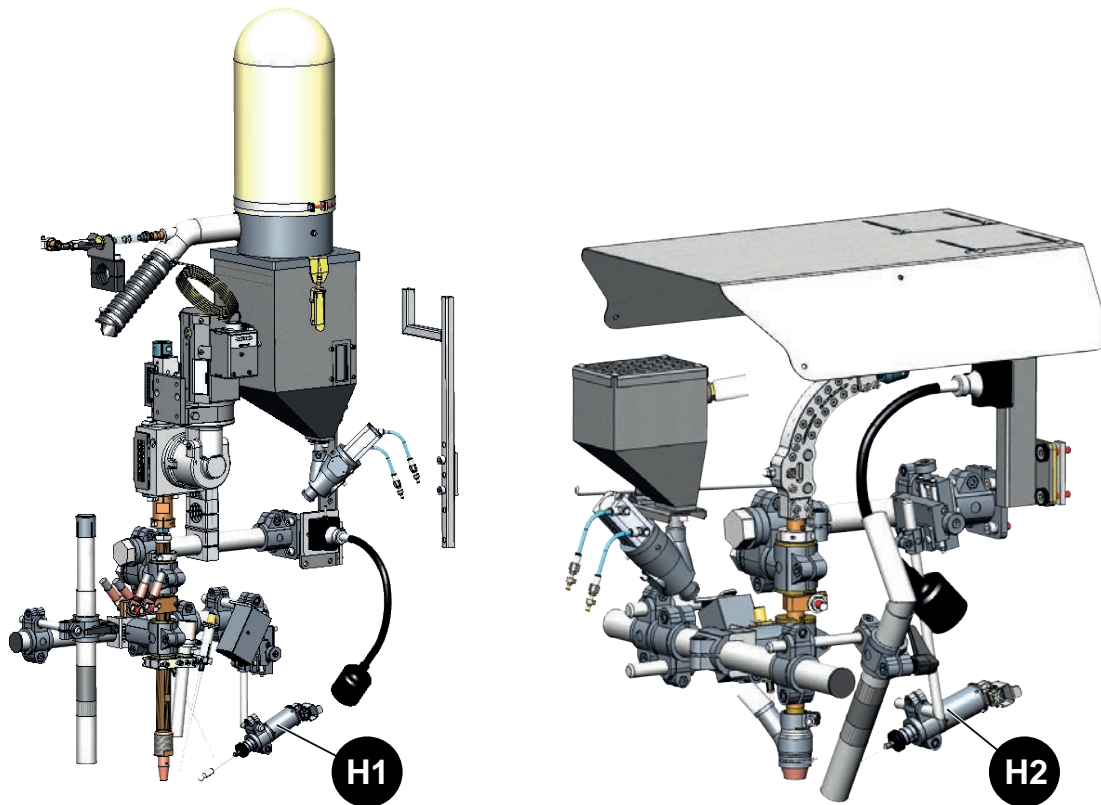

9.3 Trackmatic tracking option

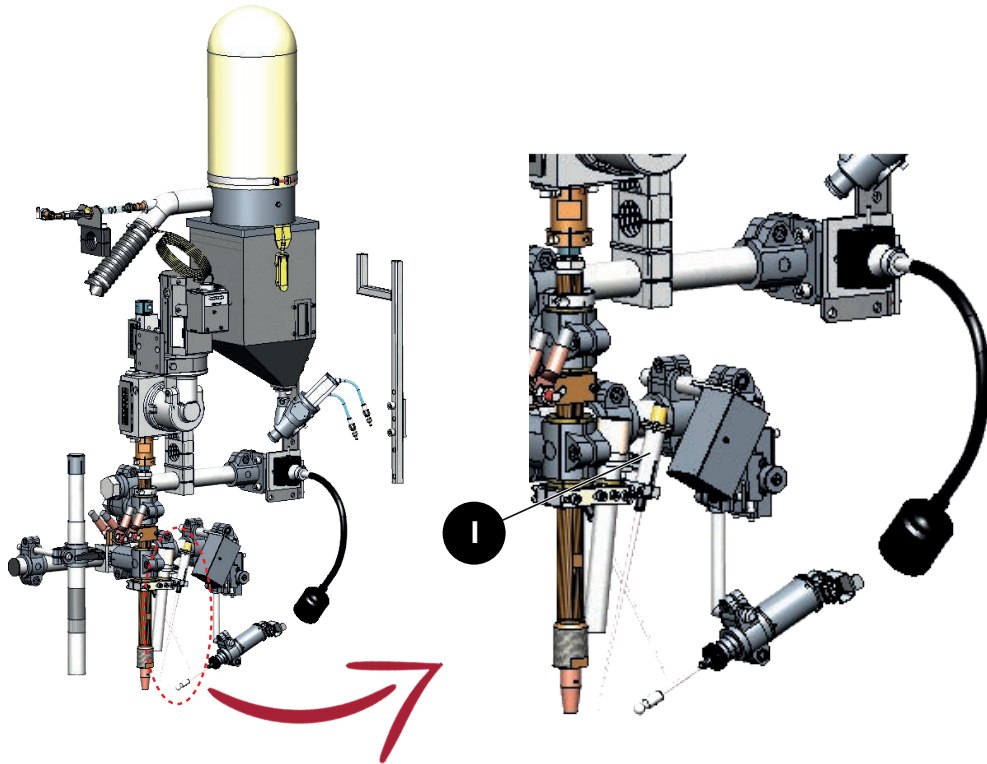

| Reference | Description | |  |
|--------------------------|-------------|------------------------------------|---|
| * Trackmatic option base | | | |
| H | H1 | Sensing finger assembly | 86956863 |
| | H2 | Internal head sensing pin assembly | |

9.4 Laser spotlight option



| Reference | Description |  |
|---|-----------------|---|
|  Laser spotlight option base | | |
| I | Laser spotlight | 86955891 |

1 - Head position adjustment

1.1 Particular precaution

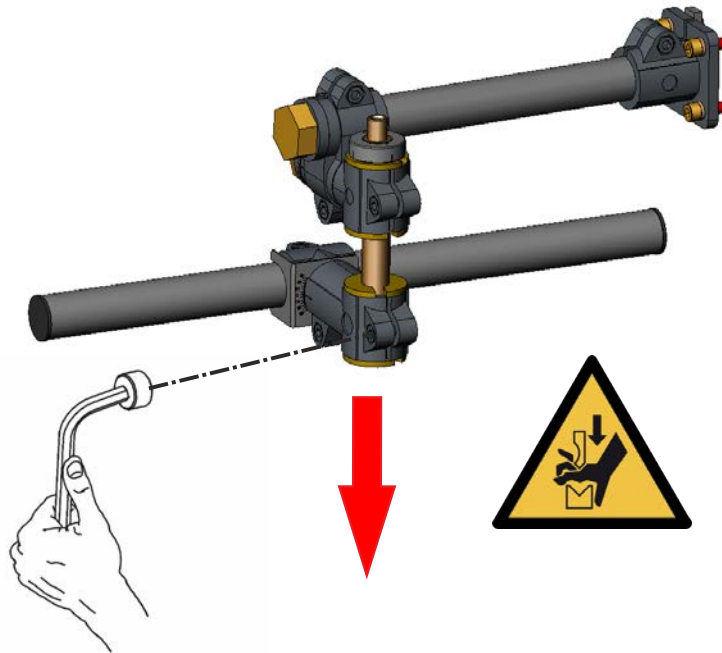

1.2 Positioning of accessories

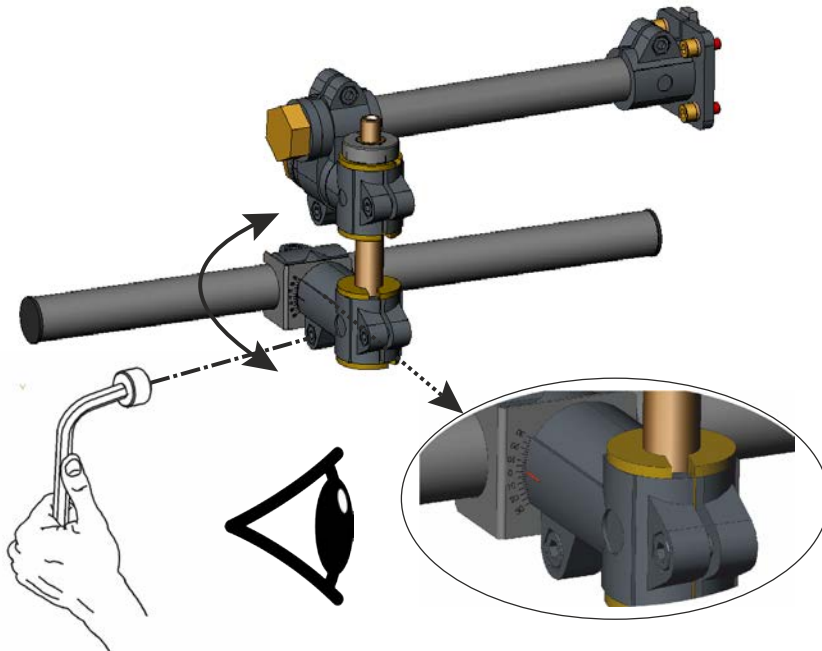

1.3 Circular/longitudinal positioning

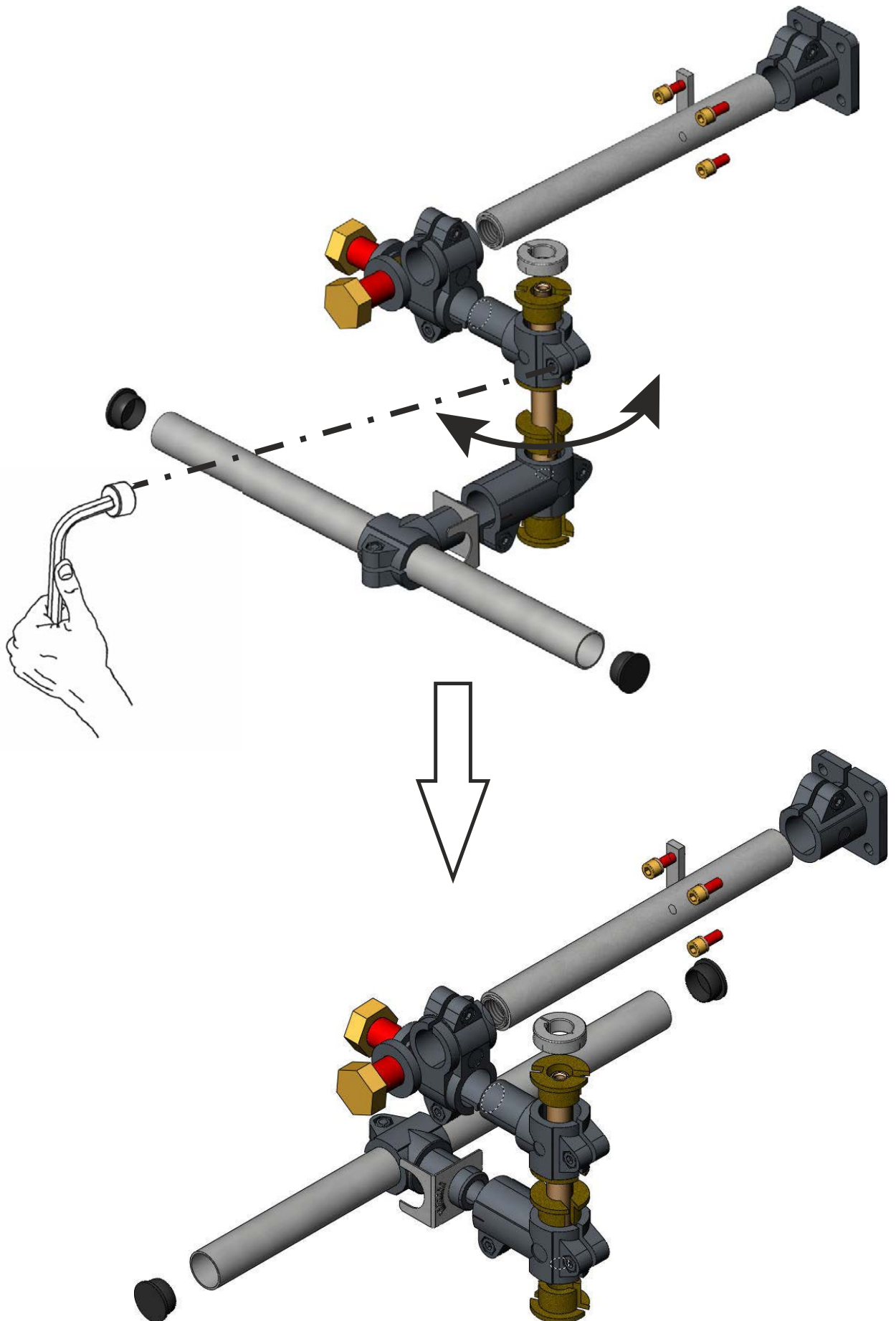

1.4 Particularity of the internal head

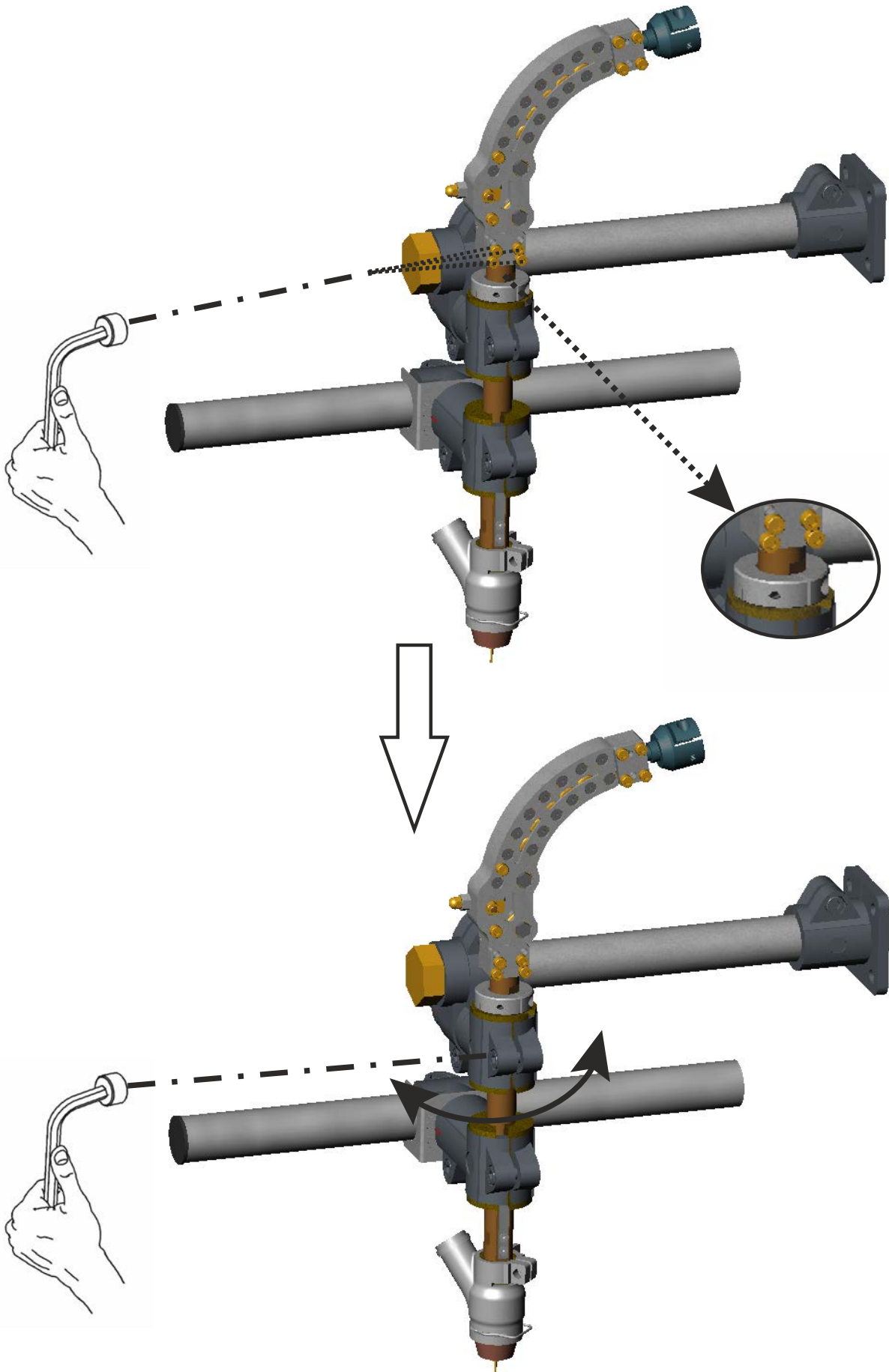

1.5 Longitudinal +/- 45° positioning

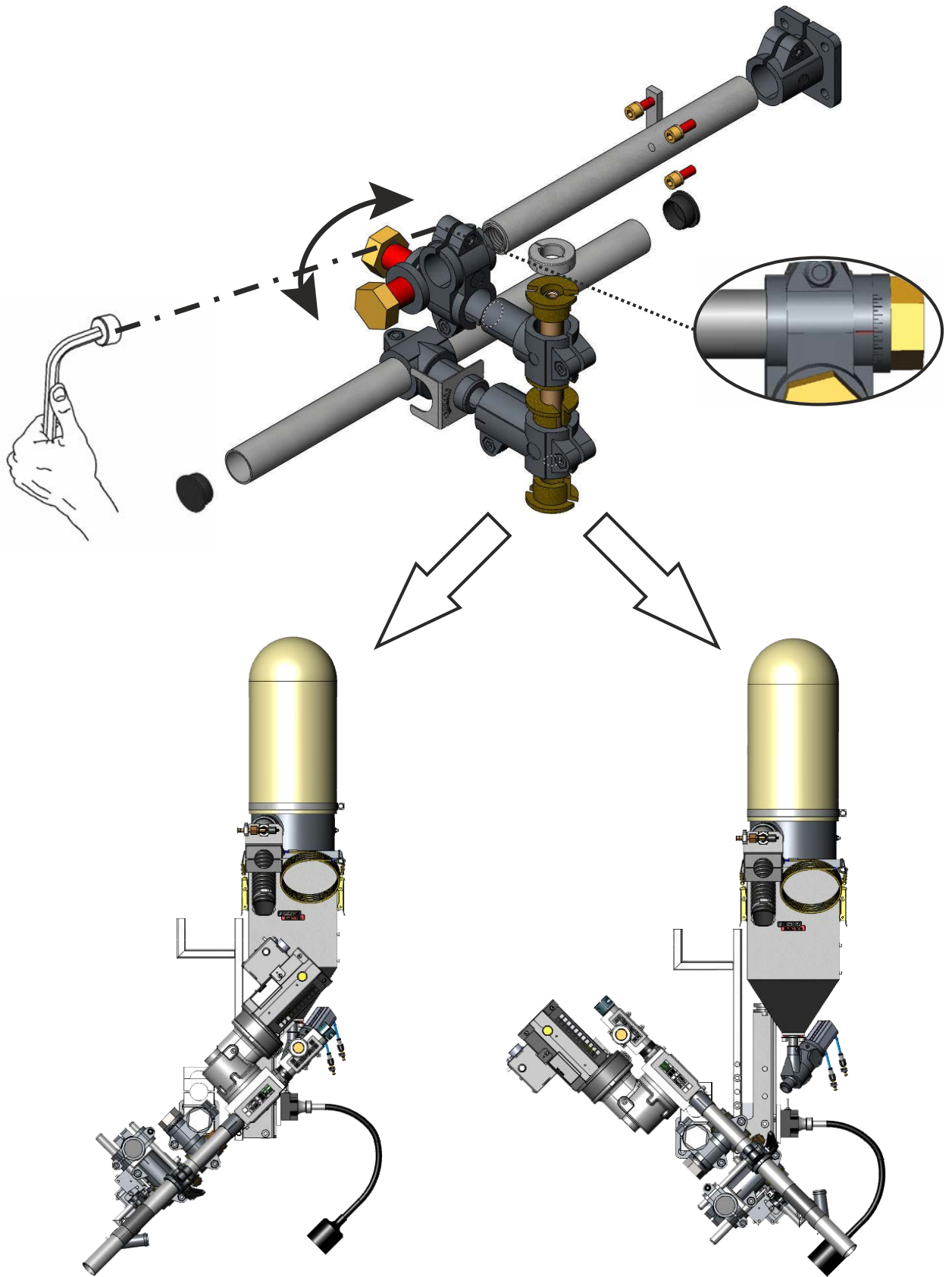

1.6 Circular +/- 45° positioning

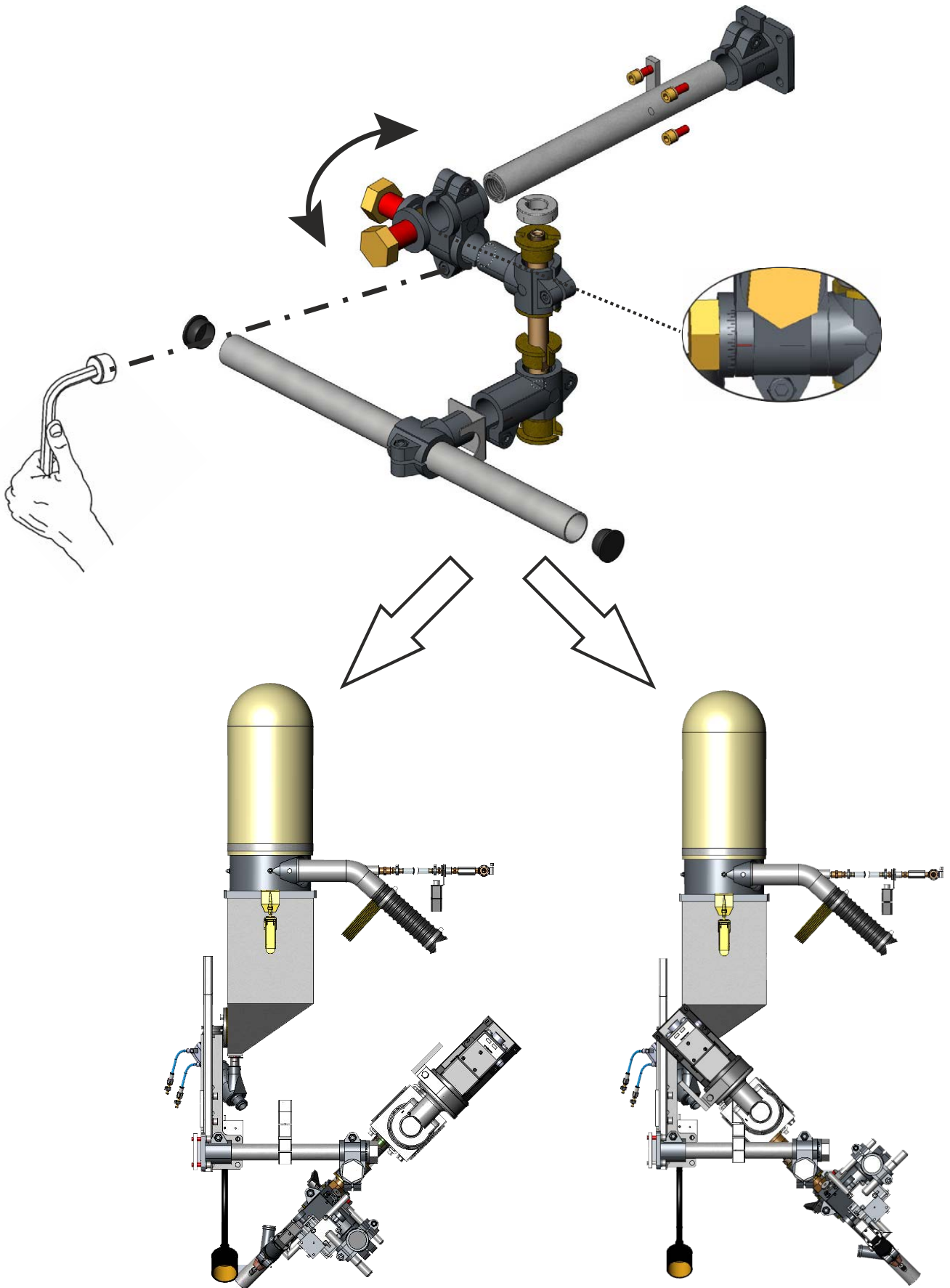

2 - Flux extraction position adjustment

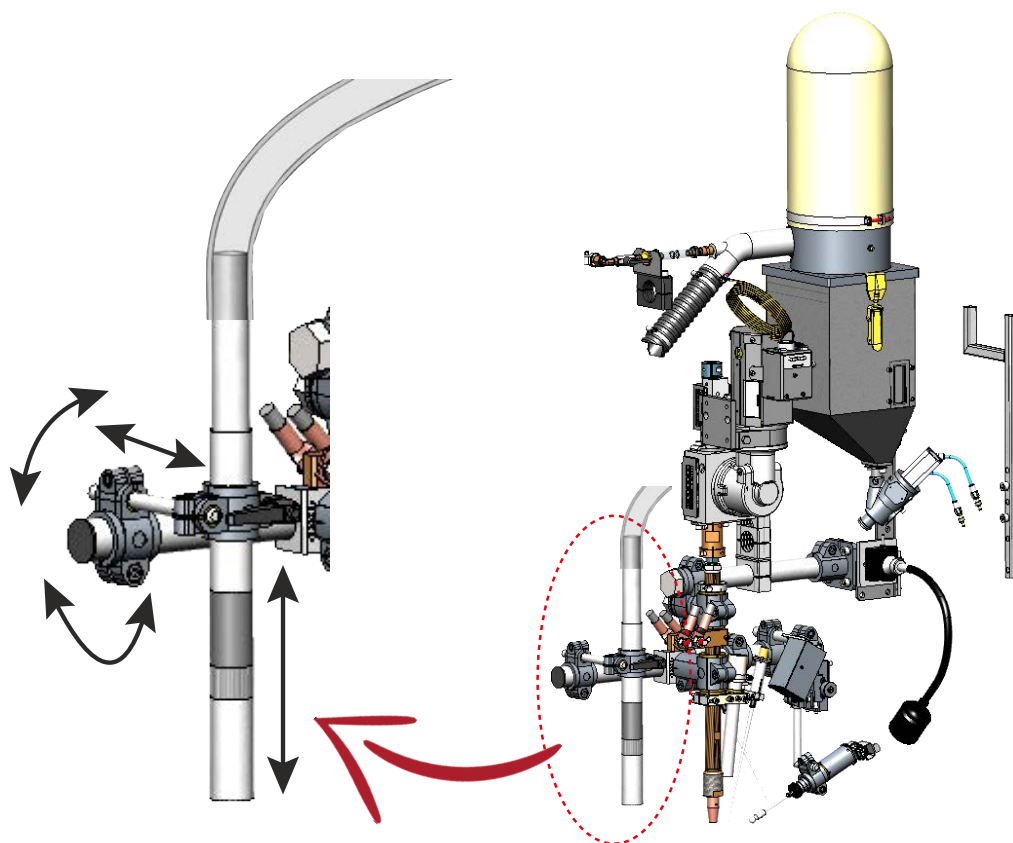

Offset allowing manual extraction of flux at the perimeter of weld.

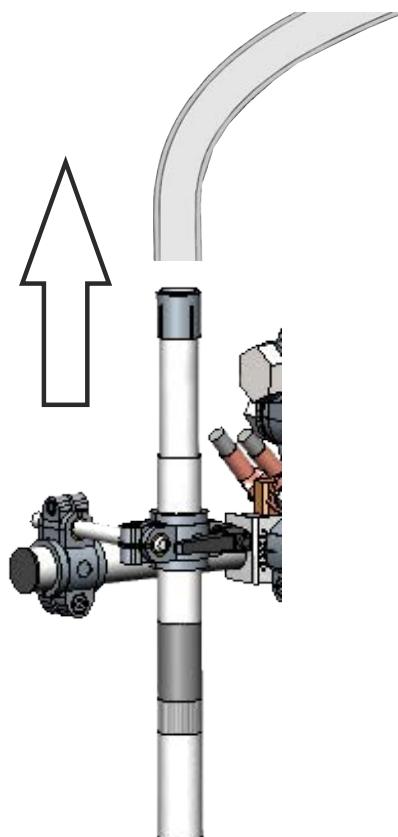

3 - Adjustment of heavy-duty flux supply

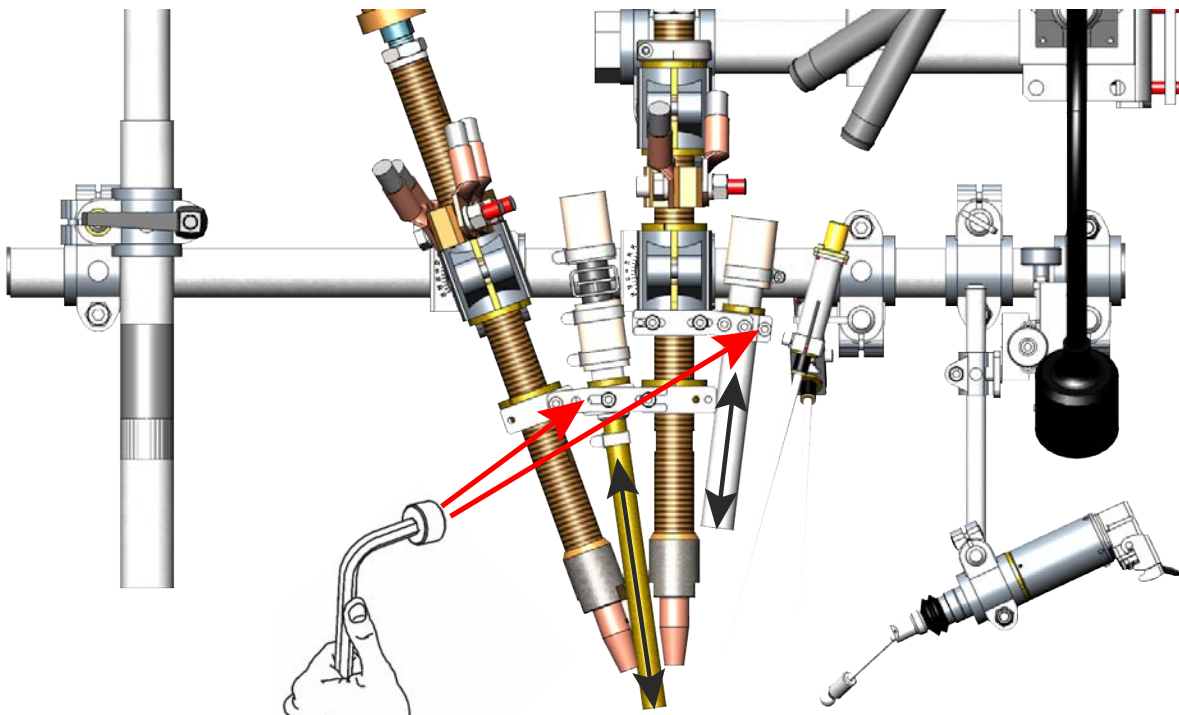
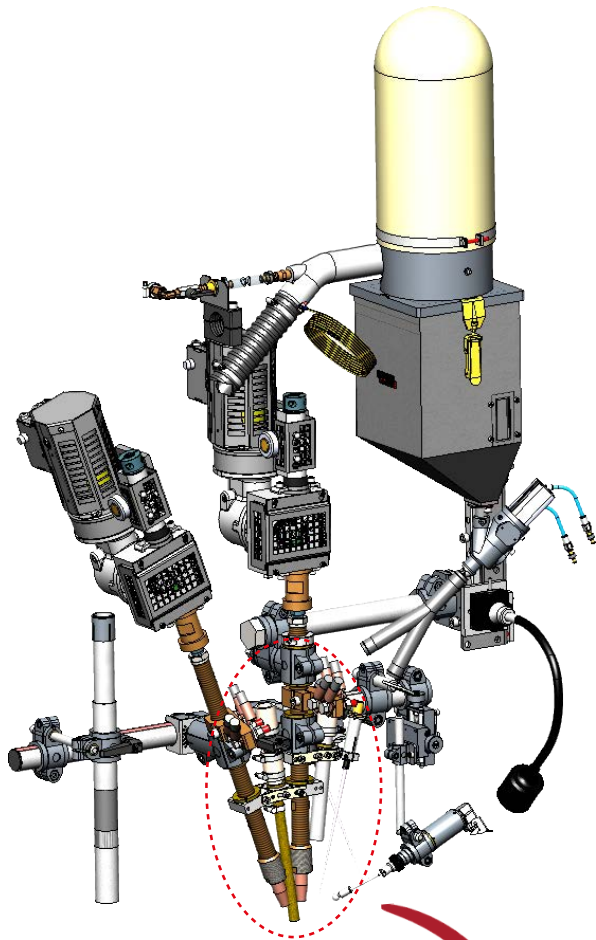

1 - Care

For a long and trouble-free life, the machine requires a minimum level of care and maintenance.

The frequency of such maintenance is indicated for production in one work shift per day, or maximum 2 hours of daily running for each movement axis. For higher production rates, increase the maintenance frequencies accordingly.

Your maintenance department could photocopy these pages to track maintenance frequencies and times and the operations completed (tick the appropriate box).







Before working on the machine, it is **MANDATORY** to lock out all the supplies of utilities to the machine (electricity, air, gas etc.).
Locking an emergency stop button is not sufficient.



1.1 Maintenance schedule



This schedule must absolutely be followed.
We recommend putting in place a traced system for tracking all your maintenance operations.

| With each replacement of the wire reel | | |
|---|--|---|
| Date of the operation: / / | | |
|  | | Blow the inside of the sheaths, the plate entry and exit wire guides, the wire supply plate, the extension end piece and the wire straightener. |
|  | | Check the wear of wire nozzles. |

| Daily | | |
|---|--|---|
| Date of the operation: / / | | |
|  | | Remove the flux recycling cover, turn it over and shake it vigorously to remove fines and dust. |
|  | | Blow the inside of the flux valve, pipes and flux supply. |
|  | | Clean the head assembly. |

| Every week | | |
|---|--|---|
| Date of the operation: / / | | |
|  | | Check the condition of the Bakelite insulating rings. |
|  | | Check all the connecting points of the power circuit. |

2 - Spare parts

Ordering procedure:

Almost all the parts of a machine or installation are referenced in the photographs and sketches.

The descriptive tables contain three types of item:

- items normally held in stock: ✓
- items not held in stock: ✗
- articles upon request: no reference

(For such parts, please complete the list of parts page and send us a copy. In the Order column, state the number of parts required and indicate the type and number of your equipment.)

For items referenced in the photographs or sketches but not included in the tables, please send us a copy of the relevant page and highlight the relevant reference.

Example:

| Ref. | Part no | Stock | Order | Description |
|------|------------|-------|-------|-------------------------|
| A1 | W000XXXXXX | ✓ | | Machine interface board |
| A2 | W000XXXXXX | ✗ | | Flow meter |
| A3 | P9357XXXX | | | Printed front plates |

| | |
|---|-------------------------|
| ✓ | normally held in stock. |
| ✗ | not in stock |
| | upon request. |

- While ordering parts, please indicate the quantity and note the number of your machine in the box above.

| | |
|---|---------|
|  Type <input type="text"/> Matricule <input type="text"/> | TYPE: |
| | Number: |

| Ref. | Part no | Stock | Order | Description |
|------|------------|-------|-------|--|
| E | W000379478 | ✓ | | Insulating rings for tubular head |
| N | W000379479 | ✓ | | Insulating rings for tubular head fitted with heavy-duty torches |
| P | W000379480 | ✓ | | Insulating rings for main or secondary flux supply |

| | |
|---|-------------------------|
| ✓ | normally held in stock. |
| ✗ | not in stock |
| | upon request. |

- While ordering parts, please indicate the quantity and note the number of your machine in the box above.

| | |
|---|---------|
|  Type <input type="text"/> Matricule <input type="text"/> | TYPE: |
| | Number: |

