

# FAB-PAK™ FW

## Dual Headstock/Triple Axis System



\*Representative design of a standard robotic welding cell

Pre-engineered Robotic Welding Systems from Lincoln Electric Automation™, including the Ferris Wheel System, can dramatically enhance part production by improving productivity, quality and safety. The Ferris Wheel standard robotic welding cell is a two zone system with headstocks in each zone for part reorientation. The Ferris Wheel positioner can rotate 180 degrees to allow single load/unload access point. It is designed for large sized parts that can be welded using the flexibility of reorientation.

The layout of the cell is available in a variety of standard configurations to meet unique manufacturing needs. It is optimized to maximize the work envelope of the robot while minimizing the floor space requirements and cost.

#### Ideal For »

- Large sized parts
- Simultaneous multiple parts

#### Parts Samples »

- **Tube/Pipe Assemblies:** king pins, boom arms, lifting booms, pipe connections, door/window frames
- **Automotive parts:** axles
- **Agricultural Equipment:** lawn mower decks, augers, tractor frames
- **Construction Equipment:** telehandler parts, skid steers, axles
- **Miscellaneous:** grills, storage racking

**What's Included:**

- » Power Wave® power source
- » AutoDrive® wire feeder
- » Magnum® PRO robotic torch
- » Ferris Wheel positioner
- » Welding robot
- » Robot basic software package
- » Wire mesh panels with weld curtains
- » Push button control
- » Training (3 days)

**Upgrades:**

- » Fume extraction hood & system
- » Tooling
- » Additional robot arm
- » Fab-Pak Cell Control
- » Robotic torch cleaning station
- » Solid metal panel walls

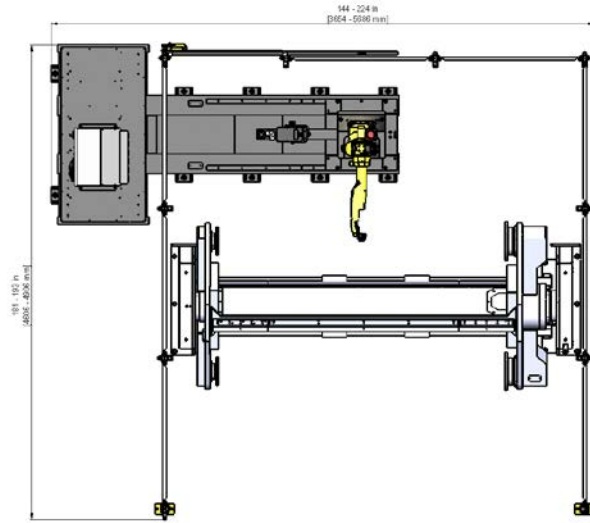

Product Name	Sweep in [mm]	Span in [mm]	Capacity per Side lb [kg]	Overall Footprint W x D in (mm)	Overall System Weight lb (kg)
Fab-Pak FW	39-59 (1000-1500)	39-118 (1000-3000)	1650-3307 (750-1500)	144-244 x 181-193 (3654-6186 x 4606-4906)	7000 (3175)

**CUSTOMER ASSISTANCE POLICY**

The business of The Lincoln Electric Company is manufacturing and selling high quality welding equipment, consumables, and cutting equipment. Our challenge is to meet the needs of our customers and to exceed their expectations. On occasion, purchasers may ask Lincoln Electric for information or advice about their use of our products. Our employees respond to inquiries to the best of their ability based on information provided to them by the customers and the knowledge they may have concerning the application. Our employees, however, are not in a position to verify the information provided or to evaluate the engineering requirements for the particular weldment. Accordingly, Lincoln Electric does not warrant or guarantee or assume any liability with respect to such information or advice. Moreover, the provision of such information or advice does not create, expand, or alter any warranty on our products. Any express or implied warranty that might arise from the information or advice, including any implied warranty of merchantability or any warranty of fitness for any customers' particular purpose is specifically disclaimed.

Lincoln Electric is a responsive manufacturer, but the selection and use of specific products sold by Lincoln Electric is solely within the control of, and remains the sole responsibility of the customer. Many variables beyond the control of Lincoln Electric affect the results obtained in applying these types of fabrication methods and service requirements.

Subject to Change – This information is accurate to the best of our knowledge at the time of printing. Please refer to [www.lincolnelectric.com](http://www.lincolnelectric.com) for any updated information.

**THE ONLY SINGLE-SOURCE AUTOMATION PROVIDER**

Lincoln Electric Automation™ has built a solutions portfolio to include all of the competencies to support your need to improve productivity, quality and safety. Lincoln Electric Automation can modify or completely customize the creation of your weld cell to meet those precise needs.

With a global network of facilities and people, you'll get quick response and personalized attention. Contact us for more information on the types of solutions available to help you produce faster, more repeatable, higher quality results.