

AUTODRIVE 4RS MACHINE SCHEMATIC G11830 REV: A.01

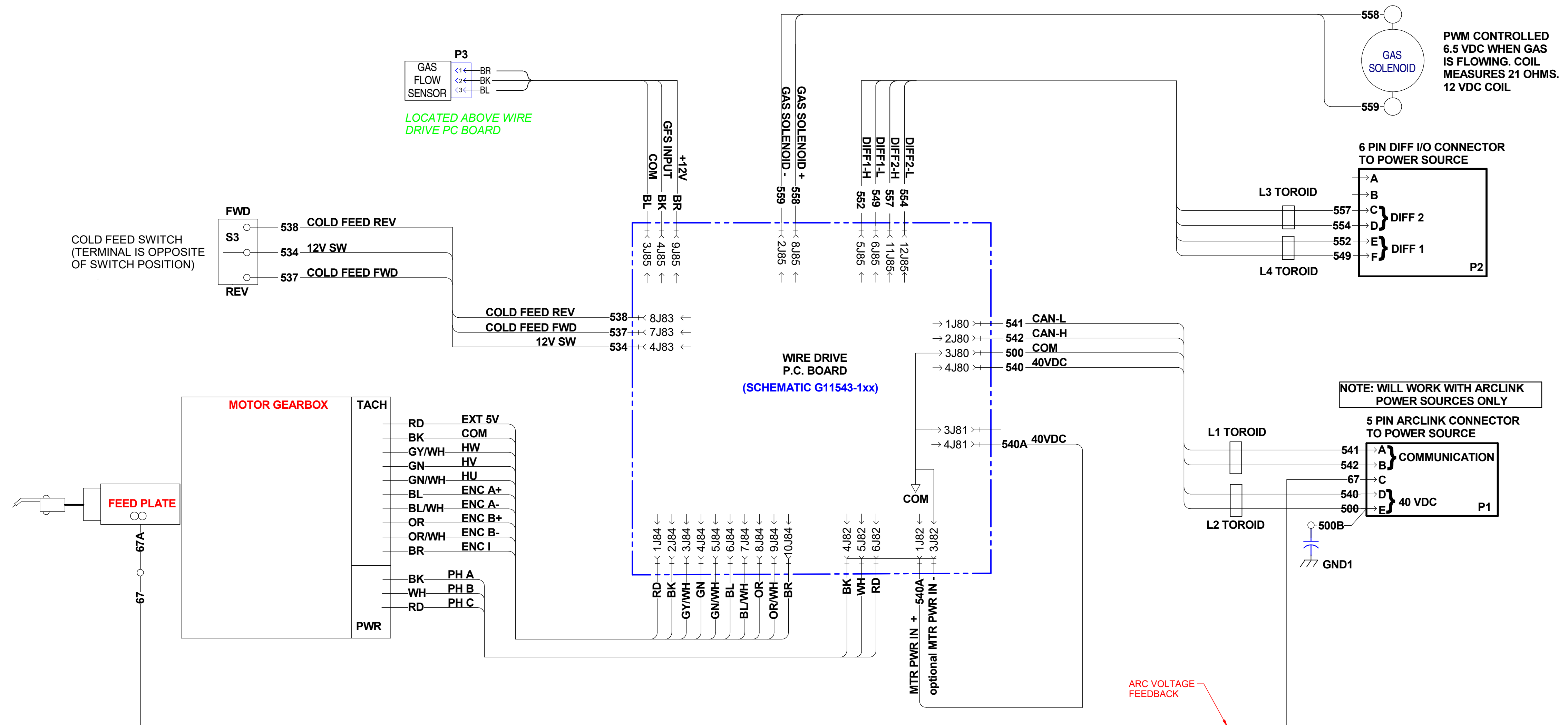

LEAD COLOR CODE:

- BK-BLACK
- BL-BLUE
- BR-BROWN
- GN-GREEN
- GY-GREY
- OR-ORANGE
- R-RED
- WH-WHITE

COMPONENT VALUE UNITS:

- CAPACITOR: MFD/VOLTS
- RESISTOR: OHMS/WATTS

CONNECTOR PIN NUMBERS:

EX. 12 PIN CONNECTOR

LABELS:

- COMMON
- FRAME
- GROUND

VIEW OF CONNECTOR ON PC BOARD:

CAVITY NUMBERING SEQUENCE (VIEWED FROM COMPONENT SIDE OF P.C. BOARD)

SLOT LOCATION:

SERIAL NUMBER AND CODE NUMBER LOCATED BELOW WIRE FEED DRIVE ROLL AREA OR TOP INSIDE.