



A LINCOLN ELECTRIC COMPANY



# SPECIALTY GAS PRESSURE & FLOW CONTROL EQUIPMENT CATALOG

# THE HARRIS PRODUCTS GROUP, A LINCOLN ELECTRIC COMPANY

One of the largest independent manufacturers of pressure and flow control equipment in the world.

Harris products are sold and used in over 85 countries. Harris Specialty Gas Equipment Division was founded to provide complete solutions to customer's special gas handling requirements. The breadth of the product line is used in ANALYTICAL LABS, chemical processing, research and development, as well as BIOTECH AND PHARMACEUTICALS. In addition to pressure control equipment, Harris offers complete gas management products for flow control, gas purification, cylinder storage and audio/visual pressure Indication.

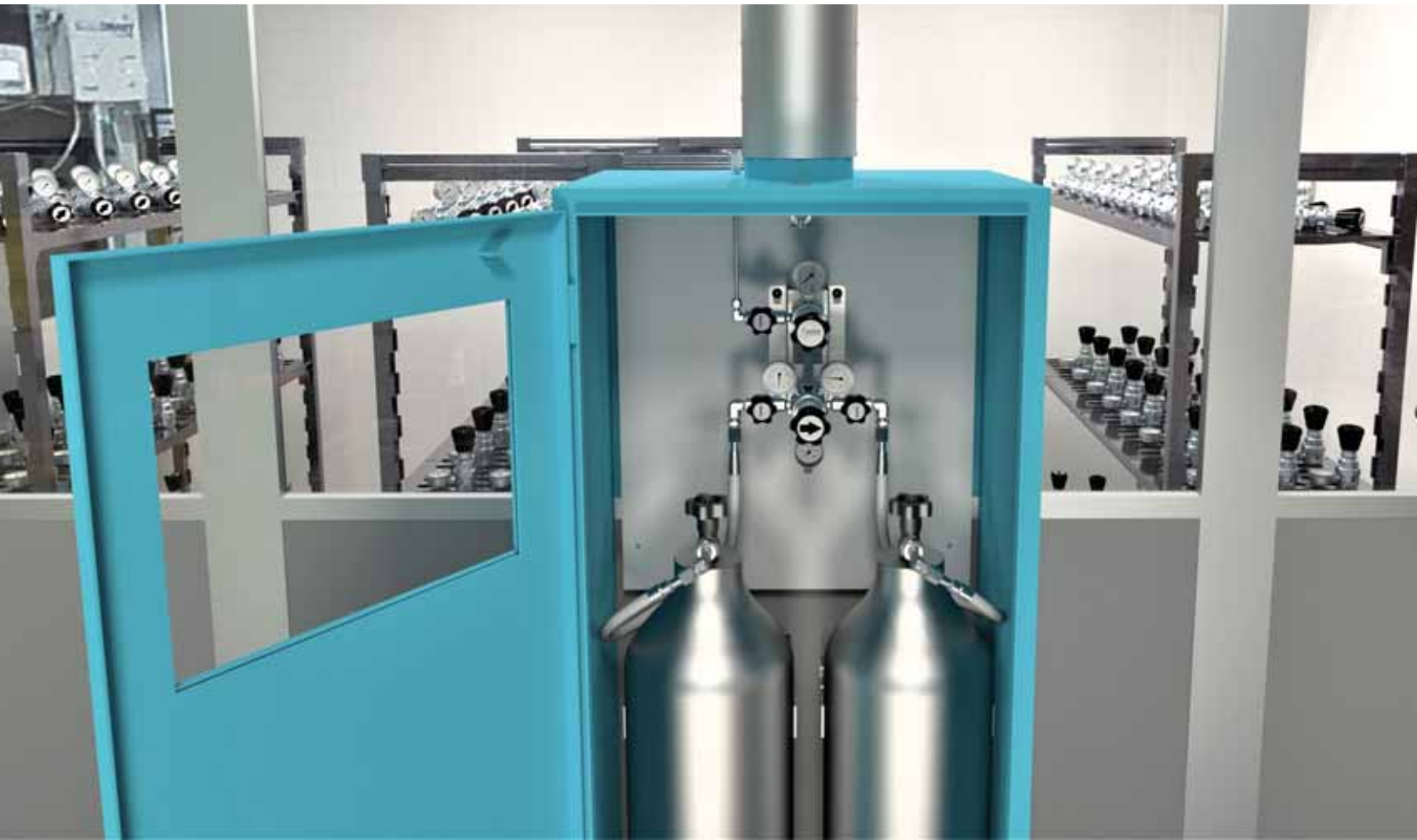

# CONTENTS

<b>THE HARRIS PRODUCTS GROUP</b>	<b>2</b>	<b>REGULATOR MOUNTING STATIONS</b>	
<b>HARRIS SPECIALTY GAS REGULATOR SELECTION PROGRAM</b>	<b>4</b>	910EZ	68
<b>HIGH PURITY PRESSURE REGULATOR SELECTION</b>	<b>6</b>	SG 910 SS	70-71
<b>High Purity Stainless Steel Barstock Regulators</b>		SG 905 BR	72-73
Model HP 741	8	<b>SWITCHOVER SYSTEMS &amp; MANIFOLDS</b>	
Model HP 742	10	920 Automatic	74
Model HP 743	12	SG905 Semi-Automatic	75
<b>HIGH PURITY BRASS BARSTOCK REGULATORS</b>		Cryogenic Manifold	76
Model HP 721	14	High Pressure Manifold	77
Model HP 722	16	SG770 back up panel	78
Model HP 723	18	Point of Use Panel	80
<b>HIGH PURITY CHROME PLATED BRASS REGULATORS</b>		<b>FLOWMETERS</b>	
Model HP 701	20	Flowmeter Selection Guide	83
Model HP 702	22	Model SG 1050	84
Model HP 703	24	Model SG 1000	85
<b>GENERAL PURPOSE REGULATORS</b>		Model SG 1100, 1127	86
Model GP 401	26	<b>PURGE ASSEMBLIES</b>	
Model GP 402	28	Typical Purge Assemblies	88-89
Model GP 403	30	Straight Purge Assemblies	90
<b>SPECIAL APPLICATION REGULATORS</b>		Cross Purge Assemblies	90
Model HP 704	32	<b>ACCESSORIES</b>	
Model GP 404	34	Diaphragm Valves, Needle Valves, and Relief Valves	92-93
Model HP 405	36	Annunciator	94
Liquid Cylinder Performance Data	38	Outlet Fittings	95
Regulator Freeze Up	39	Flashback Arrestors	95
Model HP 705	40	Checkvalves	95
Model HP 8700	42	Advanced Filter System	96
Model HP 8700SS	44	High Pressure Purifier	97
Model HP 701EN	46	Filters - Tee Type, Inline	98
<b>SPECIAL APPLICATIONS REGULATORS</b>		GAUGES	99
Model HP 721AL	48	Cylinder Brackets - Wall, Bench, Floor	102-103
Model HP 724C	50	Cylinder - Racks and Process Stations	104
Model HP 744	52	Cylinder Blankets	105
Model GP 3520	54	<b>PIGTAILS</b>	
Model HP 3530	56	Stainless Steel, Brass	101
Model HP 750	58	<b>GAS CYLINDER CABINETS</b>	
Model HP 752	60	Multiple cylinder capacities	106-107
Model 9200NC	62	<b>MEDICAL EQUIPMENT</b>	
Model MR5 & MR6	64	Model 301/1501	109
Model 717	69	Model 301P/301CBX	110
<b>GAS MANIFOLD</b>		Model 25P/25	111
Series 240 Liquid Cylinder	66	Medical Cylinders	112
		Medical gauges	112
		<b>MATERIALS COMPATIBILITY</b>	114-115
		<b>CONVERSION TABLES</b>	116
		<b>WARRANTY</b>	117



# Specialty Gas Regulator Selection Program

The Harris Specialty Gas Regulator Selector Program is available exclusively on the Harris Products Group website [www.harrisproductsgroup.com](http://www.harrisproductsgroup.com)

This convenient program allows the user to quickly and easily specify and choose regulators for high purity, toxic or corrosive gas service. Regulators with multiple features can be specified by simply choosing from the various options available. The program allows for multiple regulators to be specified where it then compiles all selections in a list which can be emailed to Harris' customer service department for a quote.

The program features graphical user controls and inputs. It also includes links to informative articles on common terminology and regulator functions.

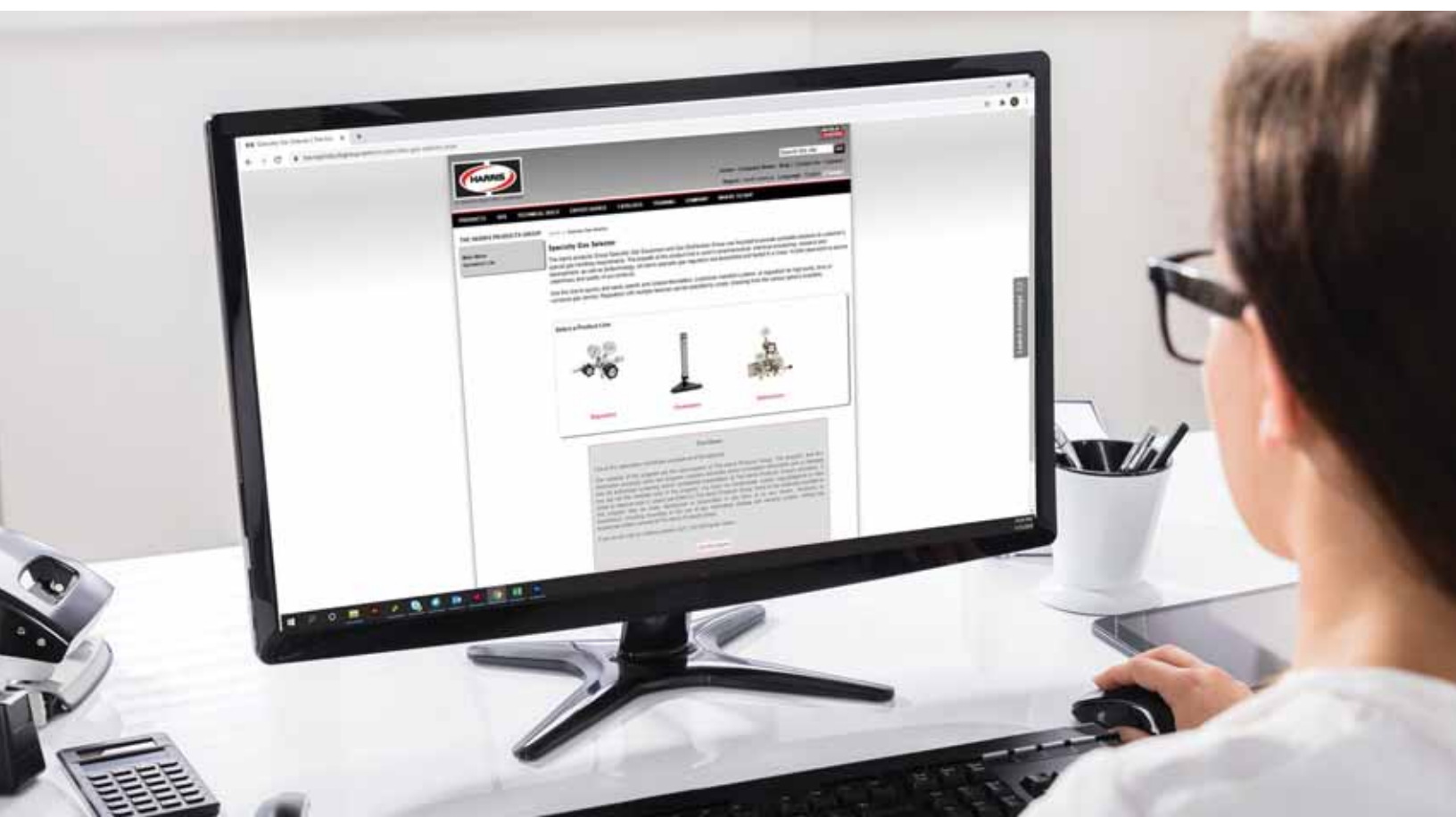

# Specialty Gas Regulator Selection Program

## 6 Simple Steps:

**Step 1**  
Choose Gas Service

**Step 2**  
Select from the appropriate models given

**Step 3**  
Select outlet pressure needed

**Step 4**  
Select inlet and outlet fittings

**Step 5**  
Select additional options or accessories

**Step 6**  
Add to quotation page which can be emailed directly to the Harris Customer Service Group.

Go to: [www.harrisproductsgroup.com/en/Specialty-Gas-Selector/Regulator-Selection.aspx](http://www.harrisproductsgroup.com/en/Specialty-Gas-Selector/Regulator-Selection.aspx)

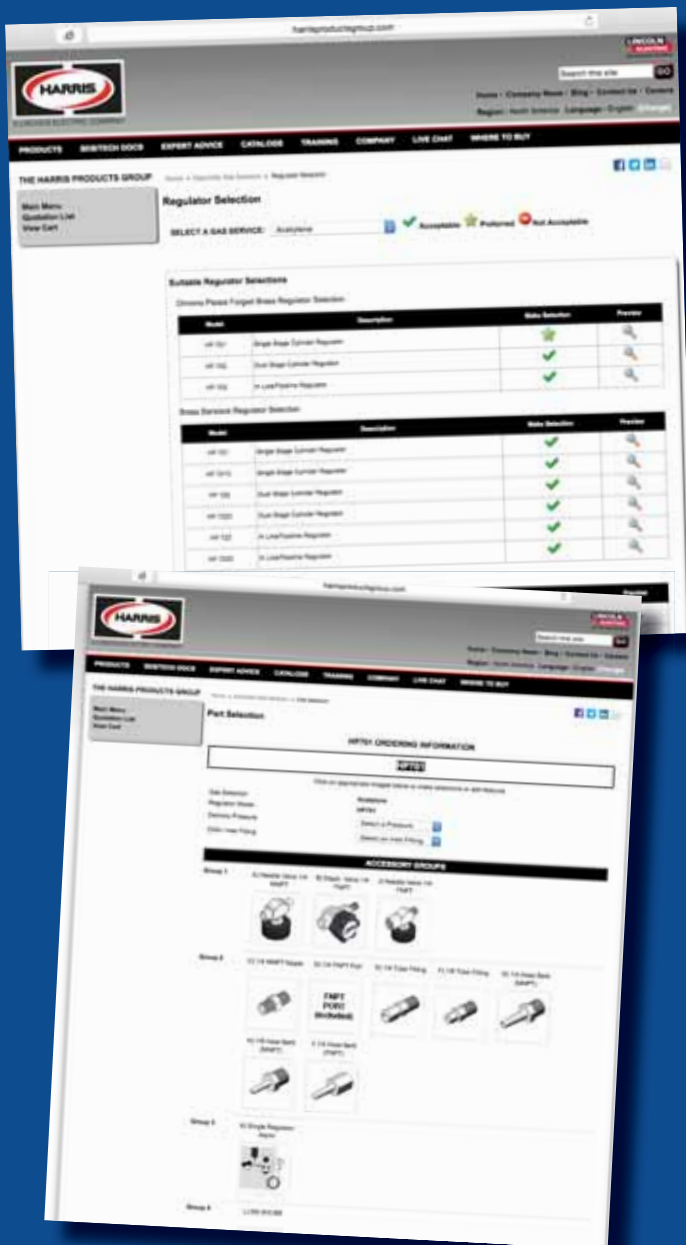

# High Purity Pressure Regulator Selection

Gases can be supplied in compressed gas high-pressure cylinders, liquid low-pressure cylinders or from low-pressure pipeline supply. The pressure from the supply source must be reduced to the desired working pressure for the application, to accomplish this a pressure reducing valve commonly referred to a regulator needs to be selected. Proper selection is critical for a safe and effective transfer of the gas from the gas supply to the instrument. Regulators are designed to control pressure. Regulators will not measure or control flow. An external device such as a flowmeter or metering valve specifically designed for flow control should be used for that purpose.

Selection of the correct regulator involves many variables. All items must be considered in making the proper regulator selection.

## Materials Compatibility

Materials used to construct the pressure regulator need to be compatible with the intended gas service. All the wetted areas (parts of the regulator in contact with the gas) must be selected to avoid any reaction with the gas that can cause contamination in the gas stream or deterioration of the regulator components. Refer to Gas Materials Compatibility Table on Page 114.

## Inlet Pressure Rating

Inlet pressures can range from low pressure in pipeline usage to high pressure from compressed gas cylinders. Regulators used in a pipeline will normally have only one gauge to indicate delivery pressure while a cylinder regulator will have two gauges; one to show inlet pressure and the other to show delivery pressure. An exception to this would be the use of regulators for liquid gas cylinders. In this application, only the delivery pressure gauge would be required since the supply pressure is generally constant. When selecting the regulator it must be capable of handling the incoming inlet pressure. When the gas is supplied from a cylinder the CGA (Compressed Gas Association) inlet connection number will dictate the maximum supply pressure. This pressure can range from 100 PSI to over 6000 PSI.

## Delivery Pressure Range

The desired working pressure for the operation may range from low pressure up to 15 PSIG to a much higher working pressure (7500-PSIG). The regulator selected must be able to supply the proper working pressure consistent with the requirements of the process.

## Gas Purity

Maintaining the purity level of the gas is of primary importance in the selection of the regulator. The selected regulator must be resistant to any introduction of contaminants that can be detrimental to the process. In addition to the proper selection of materials for gas compatibility, the design, assembly and testing of the regulator are critical items to consider in the selection process. Clean room assembly and Helium leak testing are common procedures used to insure the integrity of the regulator.

## Pressure Regulation, Single-Stage or Two-Stage Design

All regulators are designed to reduce the inlet pressure to a desired working pressure. The regulator can reduce the pressure in either one step or two steps. A single-stage regulator reduces the pressure in one step and a two-stage regulator reduces the pressure in two steps, either may be suitable for the application based on the desired pressure control. Single-Stage regulators are best suited for applications where manual periodic adjustment of the delivery pressure settings is not a problem and the inlet pressure remains constant, such as the case in gas withdrawal from liquid cylinders.

Two-stage regulators are two regulators built into a single regulator body. The first regulator (first stage) is preset at a non-adjustable pressure to reduce the incoming pressure to a lower pressure referred to as the intermediate stage. The second regulator (second stage) is adjustable within the desired delivery range. The two-stage regulator allows for steady delivery pressure without periodic adjustment, well suited for applications requiring constant pressure from full to nearly empty cylinder.

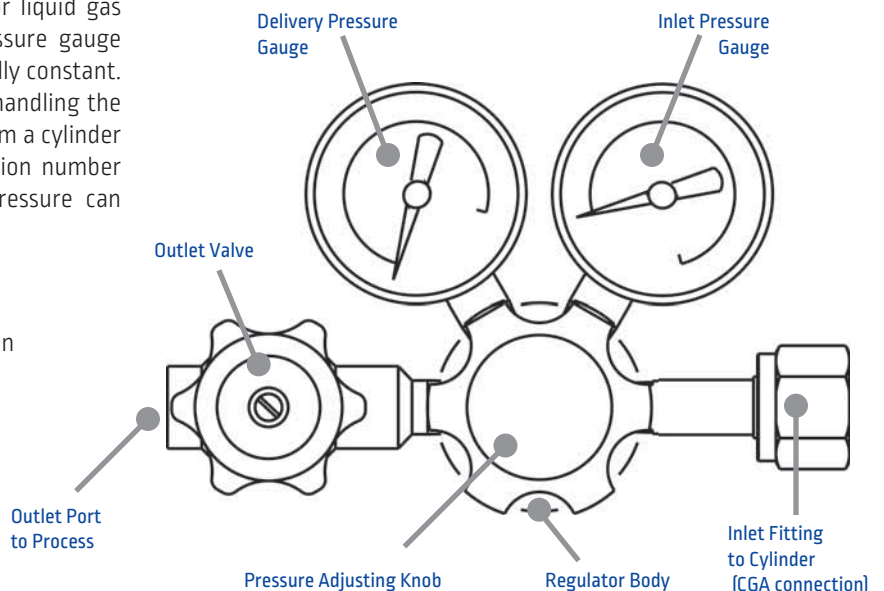

# Operation of Pressure Regulators

## Single-Stage Regulators

Gas enters the inlet (high-pressure) chamber and its pressure is indicated on the inlet pressure gauge. When the pressure adjusting knob is turned counterclockwise and completely backed out to the stop, a valve and seat assembly located between the inlet chamber and the delivery (low pressure) chamber prevents gas from moving any further. A filter located at the inlet to the valve and seat assembly, removes particulate matter from the gas stream to help protect the seat area.

Turning the pressure-adjusting knob clockwise causes the adjusting screw to push against a spring button that compresses the pressure adjusting spring. The force of the compressed spring, in turn, causes the diaphragm to flex and push against the valve. This opens the regulator allowing gas to flow from the inlet chamber to the delivery chamber of the regulator.

Gas entering the delivery pressure chamber begins to build pressure and creates a counter-force (counter to the pressure adjusting spring) on the diaphragm. This pressure is indicated on the delivery pressure gauge attached to the delivery chamber. When pressure builds sufficiently to counteract the spring tension, it pushes the diaphragm away from the poppet allowing the regulator valve to close. In this manner, pressure in the delivery chamber is controlled or regulated by the amount of spring tension placed on the diaphragm and is selectable by turning the pressure adjusting knob until desired pressure is indicated on the delivery pressure gauge.

When gas from the delivery pressure chamber is sent to the end process, the resulting decrease in gas volume in the delivery chamber causes a pressure reduction in the chamber. When this occurs, the spring tension again causes the diaphragm to push the valve open, allowing additional gas to enter the delivery chamber.

## Two-Stage Regulators

These regulators incorporate all components of a single-stage regulator. In addition, however, they also contain a second pressure adjusting spring, diaphragm, and valve seat assembly. The first stage is not user adjustable with the pressure adjusting spring "pre-compressed" at the factory. This allows the first stage to feed pressure to the second (adjustable) stage. The normal maximum delivery pressure for two-stage regulators is 500 PSI.

The second stage then performs in a manner similar to that of a single-stage regulator, except that the inlet pressure to the second stage is relatively constant. The two-step pressure reduction produces a final delivery pressure showing little effect from changes in cylinder pressure.

## Components of a Single Stage Regulator

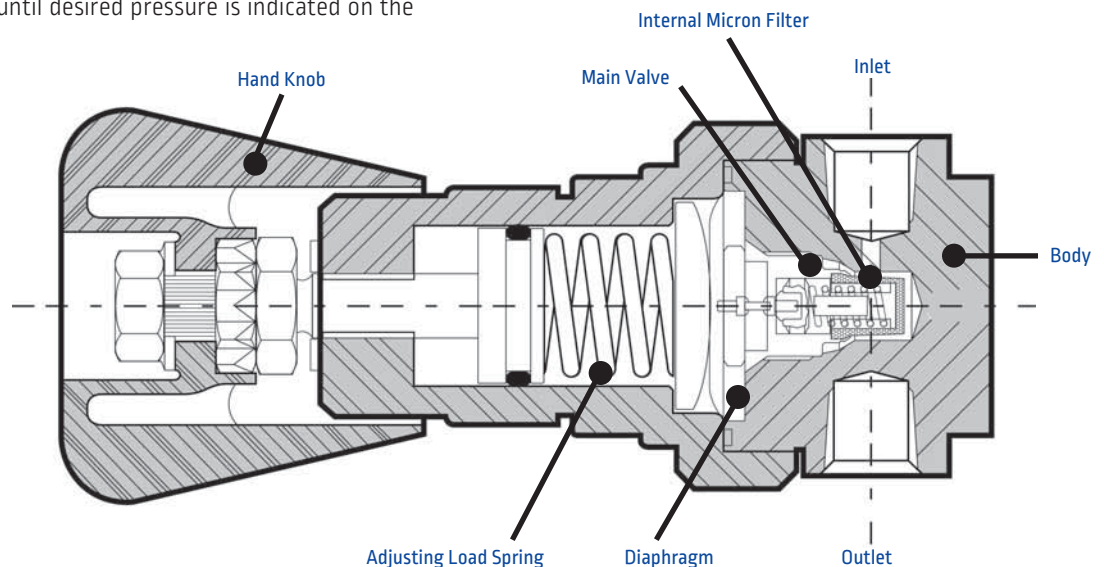

# HP 741

High Purity - Stainless Steel Barstock Regulator



Model HP 741-125-580-ADR



Model HP 741-125-580-AD shown

Model HP 741 is a single stage, stainless steel cylinder regulator for applications where a slight rise in delivery pressure from full to empty cylinder can be tolerated. The Model HP 741 is suitable for:

- Corrosive gas applications
- High purity gas applications
- Research sample systems gases
- Process analyzer gases
- Gas chromatography
- EPA protocol gases
- Laser gas systems
- Emission monitoring systems

**Recommended for corrosive gases or purity levels of Grade 6.0 [99.9999] and higher.**

## FEATURES

- 1 - 11/16" 316L stainless steel diaphragm eliminates contamination from diffusion or outgassing
- One piece encapsulated seat design includes a sintered filter to protect the seat from particulate contamination
- Chrome plated bonnet, 316L SS body and fittings
- 2" stainless steel dual scale gauges (psi/bar)
- 1 x 10<sup>-9</sup> cc/sec. inboard helium leak rate to maintain gas purity levels
- Front or back panel mountable
- Maximum inlet 3000 PSIG except for models with CGA 240 and 510 equipped with 400 PSIG inlet gauge

## MATERIALS

Body	316L Stainless Steel Barstock
Bonnet	Chrome Plated Brass Barstock
Diaphragm	316L Stainless Steel
Nozzle	316L Stainless Steel
Seat	PTFE Teflon
Seals	PTFE Teflon
Filter	Sintered Stainless Steel - 10 Micron
Seat Return Spring	316L Stainless Steel
Adjusting Knob	ABS Plastic

**SHIPS  
24  
TO  
48hr**

## RELATED OPTIONS

- Front Panel Mount Kit P/N: 9100871
- Wall mounting Bracket P/N: 9101242



## HP 741 ORDERING INFORMATION

HP 741	-	XXX	-	XXX	-	XXXX	-	XXXXX
MODEL NO.	DELIVERY PRESSURE		CGA INLET FITTING	ACCESSORIES		OPTIONS		
	DELIVERY	(OUTLET GAUGE)						
HP 741	0-15 PSIG	(30" Hg Vac-30 psi/2 bar)	240	510	A) 1/4" FNPT Diaph. Valve	2) He Leak Cert. (Inboard)		
	0-50 PSIG	(30" Hg Vac-100 psi/7 bar)	320	540	B) 1/4" MNPT Nipple	3) No Gauges		
	0-125 PSIG	(30" Hg Vac-200 psi/14 bar)	326	580	C) 1/4" FNPT Port	4) With Relief Valve		
	0-250 PSIG	(400 psi/28 bar)	330	590	D) 1/4" Tube Fitting	5) He Leak Cert.(Outboard)		
	0-500 PSIG	(1000 psi/70 bar)	346	660	E) 1/8" Tube Fitting	6) 400 PSI Inlet Gauge		
			350	705	F) Single Regulator Alarm	<b>Gas Service Must Be Specified</b>		
			000 (1/4" FNPT)		R) SG910 EZ Regulator			
			001 (1/4" MNPT)		mounting station 1 Cyl 36" Pigtail*			
					*Call for different lengths			





## FLOW DATA

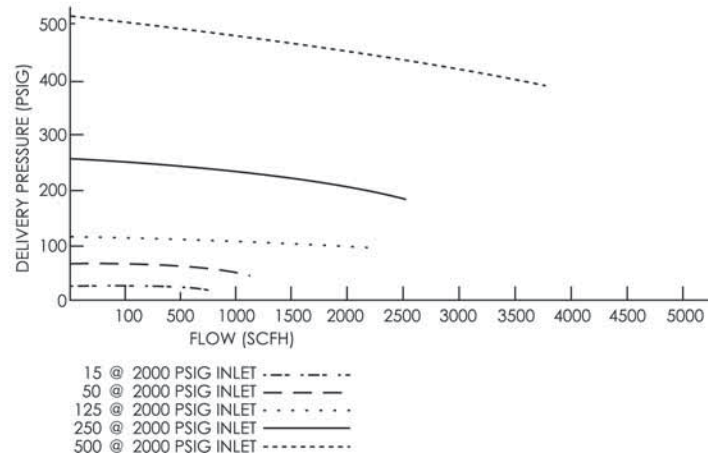
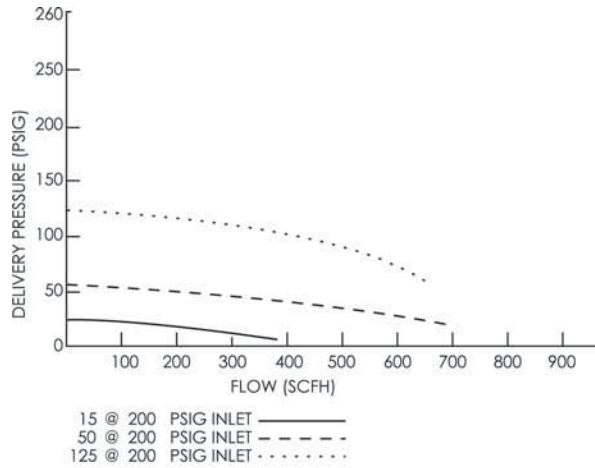

## SPECIFICATIONS

- Cv: .08
- Pressure Regulation: 1.8 PSIG/100 PSIG
- Weight: 2.92 lbs.

## DIMENSIONS

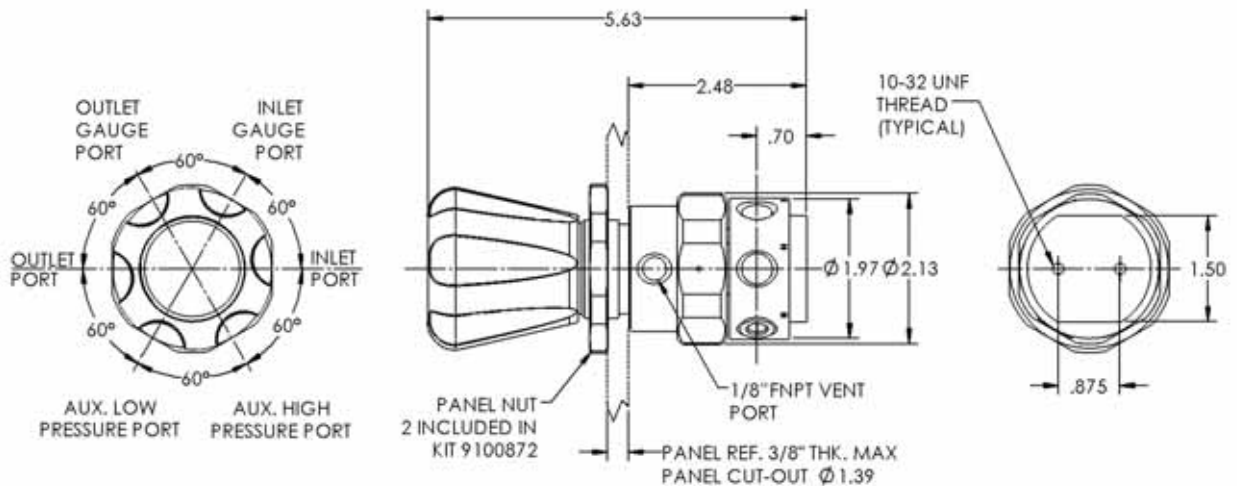

# HP 742

High Purity - Stainless Steel Barstock Regulator



Model HP 742-125-580-ADR



Model HP 742-125-580-AD shown

Model HP 742 is a two stage stainless steel cylinder regulator for constant delivery pressure from full to near empty cylinder conditions. The HP 742 is suitable for:

- Corrosive gas applications
- High purity gas applications
- Research sample systems gases
- Process analyzer gases
- Gas chromatography
- EPA protocol gases
- Laser gas systems
- Emission monitoring systems

**Recommended for corrosive gases or purity levels of Grade 6.0 (99.9999) and higher.**

## FEATURES

- 1 11/16" 316L stainless steel diaphragm eliminates contamination from diffusion or outgassing
- One piece encapsulated seat design includes a sintered filter to protect the seat from particulate contamination
- Chrome plated bonnet, 316L SS body and fittings
- 2" stainless steel dual scale gauges (psi/bar)
- Designed to 1 x 10<sup>-9</sup> cc/sec. inboard helium leak rate to maintain gas purity levels
- Maximum inlet 3000 PSIG except for models with CGA 240 and 510 equipped with 400 PSIG inlet gauge
- Front panel mountable

## RELATED OPTIONS

Front Panel Mount Kit P/N: 9100871

## MATERIALS

Body	316L Stainless Steel Barstock
Bonnet	Chrome Plated Brass Barstock
Diaphragm	316L Stainless Steel
Nozzle	316L Stainless Steel
Seat	PTFE Teflon
Seals	PTFE Teflon
Filter	Sintered Stainless Steel - 10 Micron
Seat Return Spring	316L Stainless Steel
Adjusting Knob	ABS Plastic

**SHIPS  
24  
TO  
48hr**

## HP 742 ORDERING INFORMATION

MODEL NO.	DELIVERY PRESSURE		CGA/INLET FITTING	ACCESSORIES	OPTIONS
HP 742	DELIVERY	(OUTLET GAUGE)			
	0-15 PSIG	(30" Hg Vac-30 psi/2 bar)	240	A) 1/4" FNPT Diaph. Valve	2) He Leak Cert. (Inboard)
	0-50 PSIG	(30" Hg Vac-100 psi/7 bar)	320	B) 1/4" MNPT Nipple	3) No Gauges
	0-125 PSIG	(30" Hg Vac-200 psi/14 bar)	326	C) 1/4" FNPT Port	4) With Relief Valve
	0-250 PSIG	(400 psi/28 bar)	330	D) 1/4" Tube Fitting	5) He Leak Cert. (Outboard)
	0-500 PSIG	(1000 psi/70 bar)	346	E) 1/8" Tube Fitting	
			350	F) Single Regulator Alarm	
			000 (1/4" FNPT)	R) SG910 EZ Regulator	
			001 (1/4" MNPT)	Mounting Station station 1 Cyl 36" Pigtail	
				Call for different lengths	



## FLOW DATA

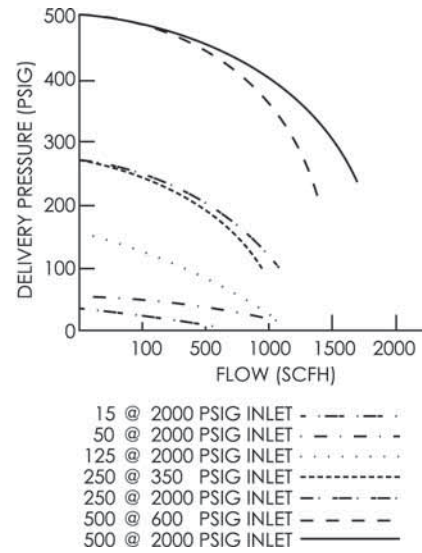
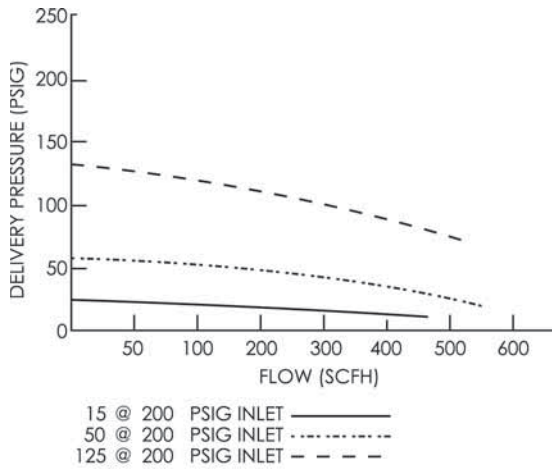

## SPECIFICATIONS

- Cv: .06
- Pressure Regulation: .05 PSIG/100 PSIG
- Weight: 4.43 lbs.

## DIMENSIONS

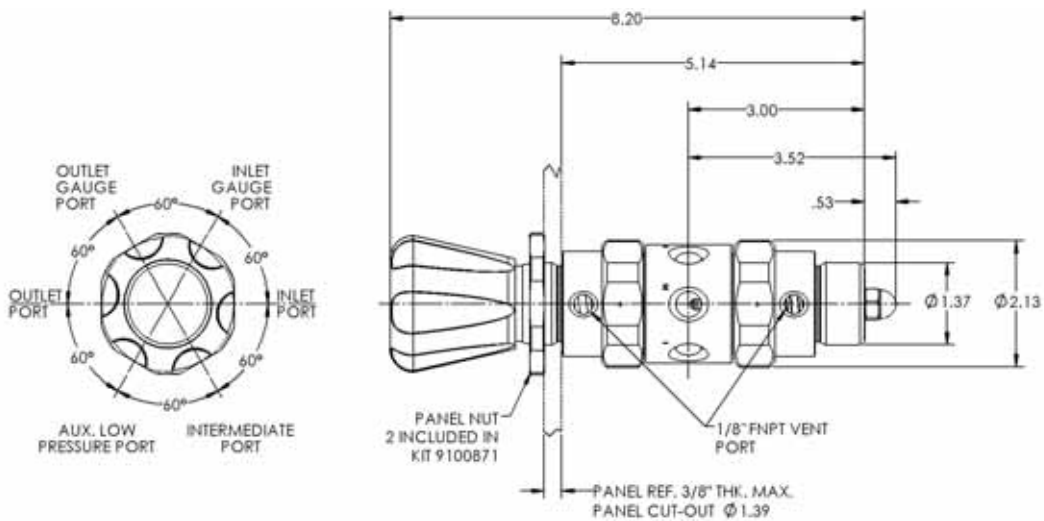

# HP 743

High Purity - Stainless Steel Barstock Regulator



Model HP 743-125-000-E shown

Model HP 743 is a single stage stainless steel pipeline regulator for pipeline and other applications up to 3000 PSIG inlet pressure. The Model HP 743 is suitable for:

- Corrosive gas applications
- High purity gas applications
- Research sample systems gases
- Process analyzer gases
- Gas chromatography
- EPA protocol gases
- Laser gas systems
- Emission monitoring systems

**Recommended for corrosive gases or purity levels of Grade 6.0 (99.9999) and higher.**

## FEATURES

- 1-11/16" 316L stainless steel diaphragm eliminates contamination from diffusion or outgassing
- One piece encapsulated seat design includes a sintered filter to protect the seat from particulate contamination
- Chrome plated bonnet, 316L body and fittings
- 2" stainless steel single scale gauge (psi/bar)
- Designed to 1 x 10<sup>-9</sup> cc/sec. inboard helium leak rate to maintain gas purity levels
- Maximum inlet 3000 PSIG
- Front or back panel mountable

## RELATED OPTIONS

Front Panel Mount Kit P/N: 9100871  
Wall mounting Bracket P/N: 9101242



## MATERIALS

Body	316L Stainless Steel Barstock
Bonnet	Chrome Plated Brass Barstock
Diaphragm	316L Stainless Steel
Nozzle	316L Stainless Steel
Seat	PTFE Teflon
Seals	PTFE Teflon
Filter	Sintered Stainless Steel - 10 Micron
Seat Return Spring	316L Stainless Steel
Adjusting Knob	ABS Plastic

**SHIPS  
24  
TO  
48hr**

## HP 743 ORDERING INFORMATION

HP 743	-	XXX	-	XXX	-	XX	-	XXXX
MODEL NO.	DELIVERY PRESSURE		INLET	ACCESSORIES		OPTIONS		
	DELIVERY	(OUTLET GAUGE)						
HP 743	0-15 PSIG	(30" Hg Vac-30 psi/2 bar)	000 (1/4" FNPT)	A. 1/4" FNPT Diaph. Valve	2. He Leak Cert. (Inboard)			
	0-50 PSIG	(30" Hg Vac-100 psi/7 bar)	001 (1/4" MNPT)	B. 1/4" MNPT Nipple	3. No Gauge			
	0-125 PSIG	(30" Hg Vac-200 psi/14 bar)	002 (1/4" Tube fitting)	C. 1/4" FNPT Port	4. With Relief Valve			
	0-250 PSIG	(400 psi/28 bar)	003 (1/8" Tube fitting)	D. 1/4" Tube Fitting	5. He Leak Cert (Outboard)			
	0-500 PSIG	(1000 psi/70 bar)		E. 1/8" Tube Fitting				

NOTE: Regulators with delivery pressure above 15 PSIG should not be used with acetylene.





## FLOW DATA

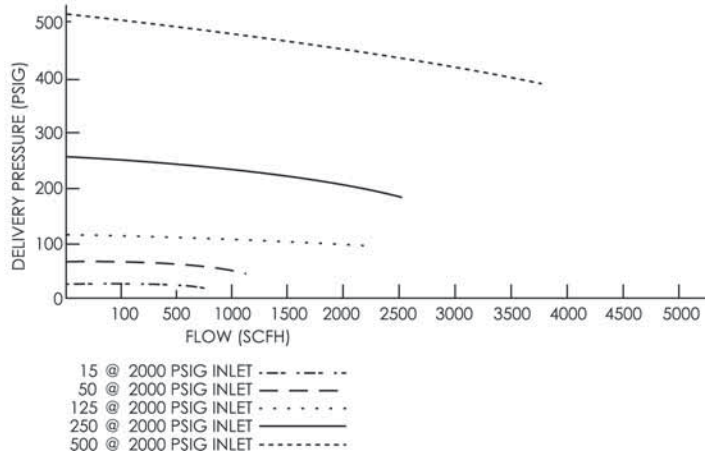
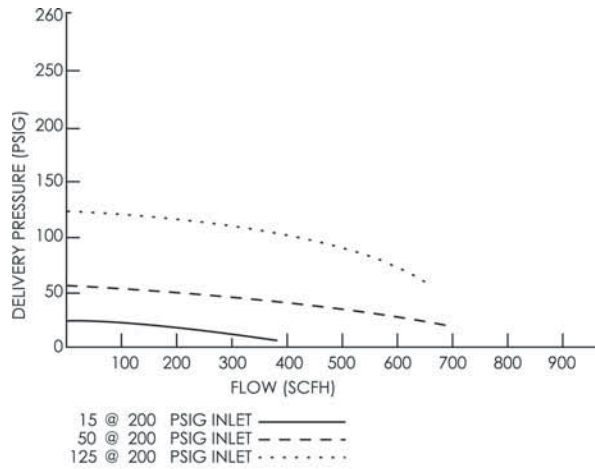

## SPECIFICATIONS

- Cv: .08
- Pressure Regulation: 1.8 PSIG/100 PSIG
- Weight: 2.68 lbs.

## DIMENSIONS

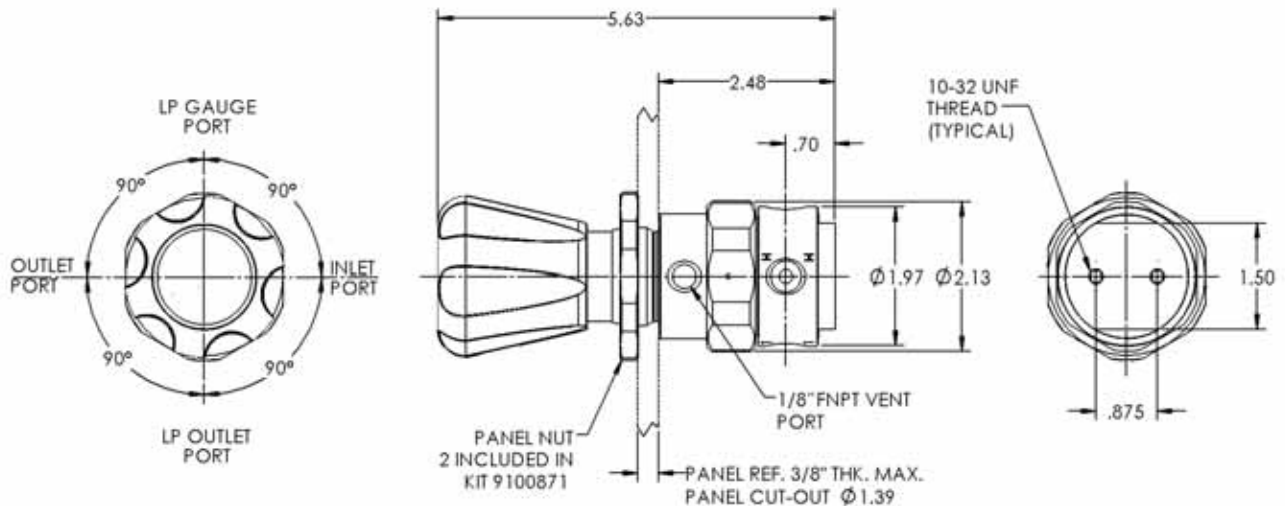

# HP 721

High Purity - Brass Barstock Regulator



Model HP 721-125-580-ADR



Model HP 721-125-350-B shown



Model HP 721 is a single stage cylinder regulator available in brass (HP 721) or chrome plated brass (HP 721C) barstock for pressure control of non corrosive gases when pressure rise is not critical. The HP 721 is suitable for:

- High purity gas applications
- Research sample systems gases
- Process analyzer gases
- Gas chromatography
- EPA protocol gases
- Laser gas systems
- Emission monitoring systems

**Recommended for gas purity levels of Grade 5.0 (99.999) and higher.**

## FEATURES

- 1-11/16" 316L stainless steel diaphragm eliminates contamination from diffusion or outgassing
- One piece encapsulated seat design includes a sintered filter to protect the seat from particulate contamination
- 2" dual scale brass gauges (psi/bar)
- Designed to 1 x 10<sup>-9</sup> cc/sec. inboard helium leak rate to maintain gas purity levels
- Front or back panel mountable
- Maximum inlet 3000 PSIG except for models with CGA 300 and 510 equipped with 400 PSIG Inlet gauge
- External relief valve standard

## RELATED OPTIONS

Front Panel Mount Kit P/N: 9100871  
Wall Mounting Bracket P/N: 9101242



## MATERIALS

Body/Bonnet	Brass Barstock	<b>SHIPS 24 TO 48hr</b>
Diaphragm	316L Stainless Steel	
Nozzle	Brass	
Seat	PTFE Teflon	
Seals	PTFE Teflon	
Filter	Nickel-Plated Sintered Bronze - 10 Micron	
Seat Return Spring	PH17-7 Stainless Steel	
Adjusting Knob	ABS Plastic	

## HP 721 ORDERING INFORMATION

HP 721	-	XXX	-	XXX	-	XXXX	-	XXXXX
MODEL NO.	DELIVERY PRESSURE		CGA/INLET FITTING	ACCESSORIES	OPTIONS			
	DELIVERY	(OUTLET GAUGE)						
HP 721	0-15 PSIG	(30" Hg Vac-30 psi/2 bar)	000 (1/4" FNPT)	350	A) 1/4" MNPT Needle Valve	1. Without Relief Valve		
HP 721C (chrome plated)	0-50 PSIG	(30" Hg Vac-100 psi/7 bar)	001 (1/4" MNPT)	510	B) 1/4" FNPT Diaph. Valve	2. He Leak Cert. (Inboard)		
	0-125 PSIG	(30" Hg Vac-200 psi/14 bar)	300	540	C) 1/4" MNPT Nipple	3. No Gauges		
	0-250 PSIG	(400 psi/28 bar)	320	580	D) 1/4" FNPT Port	5. He Leak Cert. (Outboard)		
	0-500 PSIG	(1000 psi/70 bar)	326	590	E) 1/4" Tube Fitting	6. 400 psi inlet gauge <b>Gas Service Must be Specified</b>		
			346		F) 1/8" Tube Fitting			
					G) Single Regulator Alarm			
					R) SG 910 EZ BR Regulator Mounting Station 1 cyl 36" Pigtail*			

\*Call for different lengths

Orders: 1.800.733.4043

THE HARRIS PRODUCTS GROUP  
www.harrisproductsgroup.com



### FLOW DATA

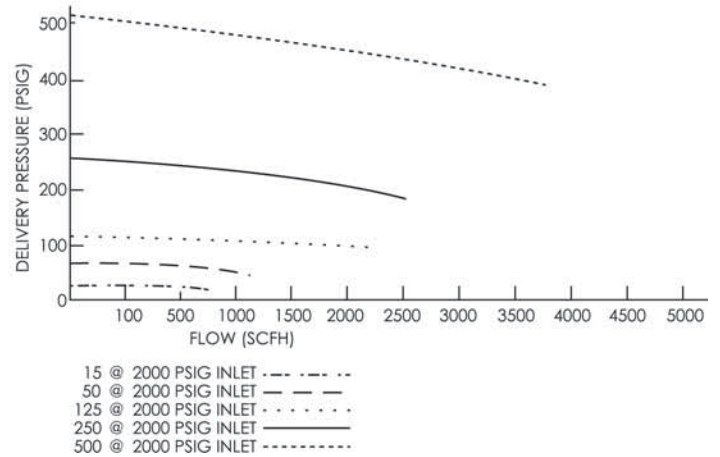
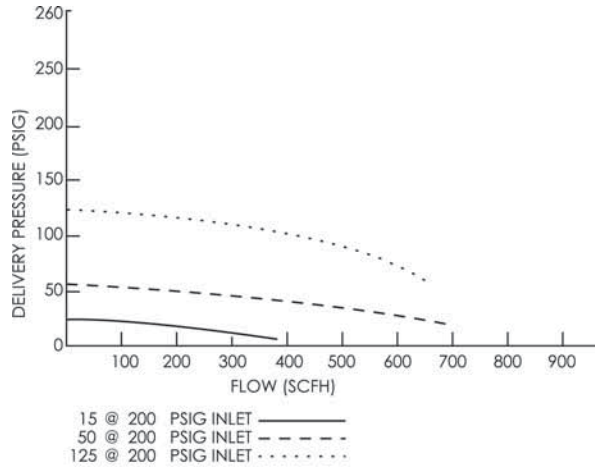

### SPECIFICATIONS

- Cv: .08
- Pressure Regulation: 1.8 PSIG/100 PSIG
- Weight: 2.92 lbs.

### DIMENSIONS

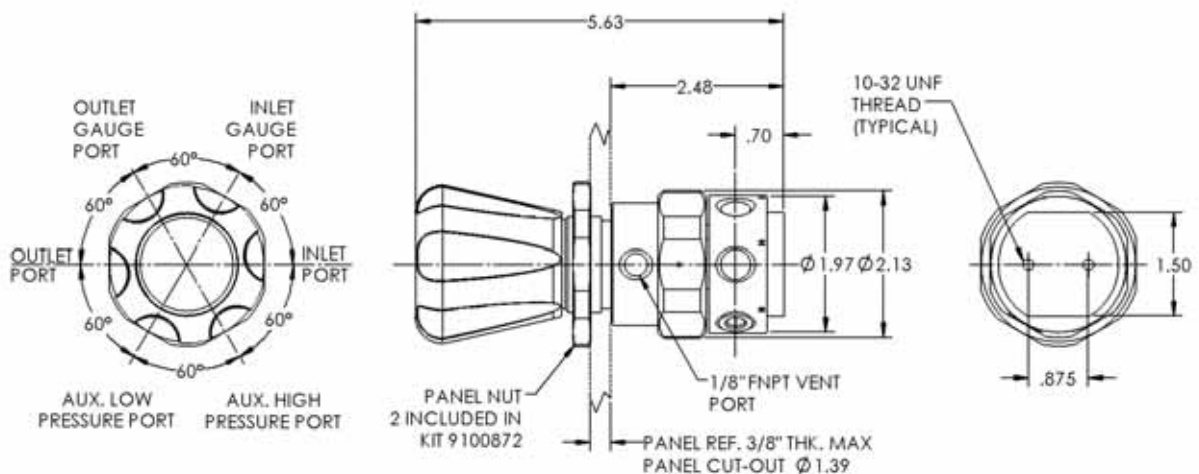

# HP 722

High Purity - Brass Barstock Regulator



Model HP 742-125-580-ADR



Model HP 722-125-320-B shown

Model HP 722 is a two stage cylinder regulator available in brass (HP 722) or chrome plated brass (HP 722C) barstock for constant delivery pressure from full to near empty cylinder conditions. The HP 722 is suitable for:

- High purity gas applications
- Research sample systems gases
- Process analyzer gases
- Gas chromatography
- EPA protocol gases
- Laser gas systems
- Emission monitoring systems

**Recommended for gas purity levels of Grade 5.0 (99.999) and higher.**

## FEATURES

- 1 11/16" 316L stainless steel diaphragm eliminates contamination from diffusion or outgassing
- One piece encapsulated seat design includes a sintered filter to protect the seat from particulate contamination
- 2" dual scale brass gauges (psi/bar)
- Designed to 1 x 10<sup>-9</sup> cc/sec. inboard helium leak rate to maintain gas purity levels
- Front and rear panel mountable
- Maximum inlet 3000 PSIG except for models with CGA 300 and 510 equipped with 400 PSIG inlet gauge
- External relief valve standard

## RELATED OPTIONS

Front Panel Mount Kit P/N: 9100871

## MATERIALS

Body/Bonnet	Brass Barstock	
Diaphragm	316L Stainless Steel	
Nozzle	Brass	
Seat	PTFE Teflon	
Seals	PTFE Teflon	
Filter	Nickel-Plated Sintered Bronze - 10 Micron	
Seat Return Spring	PH17-7 Stainless Steel	
Adjusting Knob	ABS Plastic	

## HP 722 ORDERING INFORMATION

MODEL NO.	DELIVERY PRESSURE DELIVERY	(OUTLET GAUGE)	CGA / INLET FITTING	ACCESSORIES	OPTIONS
HP 722	0-15 PSIG	(30" Hg Vac-30 psi/2 bar)	000 (1/4" FNPT)	346	1. Without Relief Valve
HP 722C (chrome plated)	0-50 PSIG	(30" Hg Vac-100 psi/ 7 bar)	001 (1/4" MNPT)	350	2. He Leak Cert. (Inboard)
	0-125 PSIG	(30" Hg Vac-200 psi/14 bar)	296	510	3. No Gauges
	0-250 PSIG	(400 psi/28 bar)	300	540	5. He Leak Cert. (Outboard)
	0-500 PSIG	(1000 psi/70 bar)	320	580	
			326	590	
				F. 1/8" Tube Fitting	
				G. Single Regulator Alarm	
				R. SG 910 EZ BR Regulator Hose Barb	
				Mounting Station 1 cyl 36" Pigtail	
				Call for different lengths	





## FLOW DATA

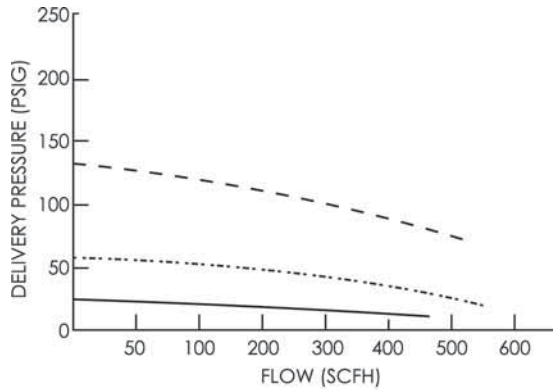

15 @ 200 PSIG INLET ———  
 50 @ 200 PSIG INLET - - - - -  
 125 @ 200 PSIG INLET - - - - -

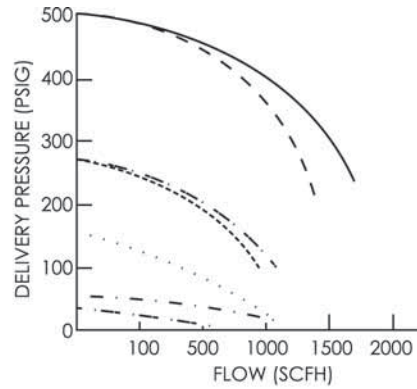

15 @ 2000 PSIG INLET - - - - -  
 50 @ 2000 PSIG INLET - - - - -  
 125 @ 2000 PSIG INLET - - - - -  
 250 @ 350 PSIG INLET - - - - -  
 250 @ 2000 PSIG INLET - - - - -  
 500 @ 600 PSIG INLET - - - - -  
 500 @ 2000 PSIG INLET ———

## SPECIFICATIONS

- Cv: .06
- Pressure Regulation: .05 PSIG/100 PSIG
- Weight: 4.43 lbs.

## DIMENSIONS

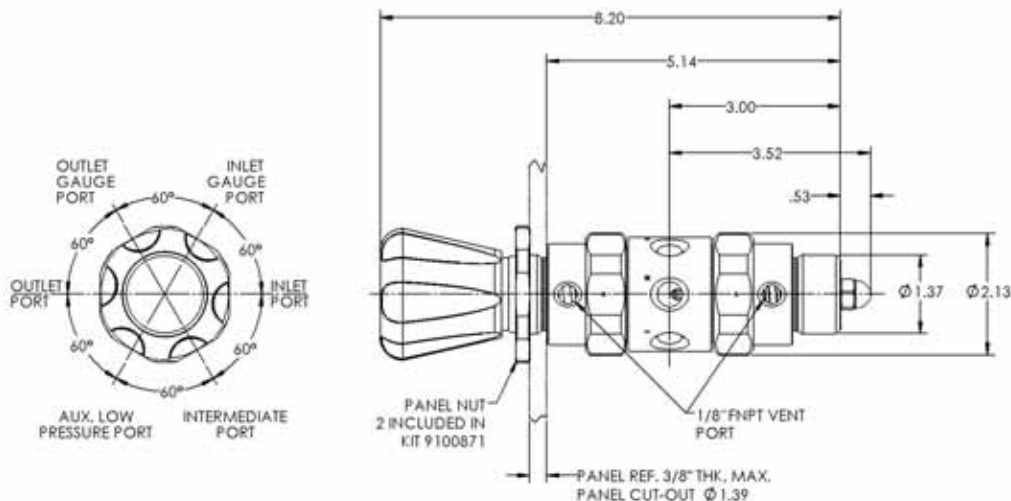

# HP 723

High Purity - Brass Barstock Regulator



Model HP 723C-125-000-E shown

## MATERIALS

Body/Bonnet	Brass Barstock
Diaphragm	316L Stainless Steel
Nozzle	Brass
Seat	PTFE Teflon
Seals	PTFE Teflon
Filter	Nickel-Plated Sintered Bronze - 10 Micron
Seat Return Spring	PH 17-7 Stainless Steel
Adjusting Knob	ABS Plastic

**SHIPS  
24  
TO  
48hr**

Model HP 723 is a single stage pipeline regulator available in brass (HP 723) or chrome plated brass (HP 723C) barstock and are rated up to 3000 psig inlet pressure.

The HP 723 is suitable for:

- High purity gas applications
- Research sample systems gases
- Process analyzer gases
- Gas chromatography
- EPA protocol gases
- Laser gas systems
- Emission monitoring systems

**Recommended for gas purity levels of Grade 5.0 (99.999) and higher.**

## FEATURES

- 1-11/16" 316L stainless steel diaphragm eliminates contamination from diffusion or outgassing
- One piece encapsulated seat design includes a sintered filter to protect the seat from particulate contamination
- 2" dual scale brass gauge (psi/bar)
- Designed to 1 x 10<sup>-9</sup> cc/sec. inboard helium leak rate to maintain gas purity levels
- Front or back panel mountable
- External relief valve standard
- Maximum inlet 3000 PSIG



## RELATED OPTIONS

Front Panel Mount Kit P/N: 9100871

## HP 723 ORDERING INFORMATION

HP 723	-	XXX	-	XXX	-	XX	-	XXXX
MODEL NO.	DELIVERY PRESSURE		INLET	ACCESSORIES		OPTIONS		
	DELIVERY	(OUTLET GAUGE)						
HP 723	0-15 PSIG	(30" Hg Vac-30 psi/2 bar)	000 (1/4" FNPT)	A. 1/4" MNPT Needle Valve	1. Without Relief Valve			
HP 723C (chrome plated)	0-50 PSIG	(30" Hg Vac-100 psi/7 bar)	001 (1/4" MNPT)	B. 1/4" FNPT Diaph. Valve	2. He Leak Cert. (Inboard)			
	0-125 PSIG	(30" Hg Vac-200 psi/14 bar)	002 (1/4" Tube fitting)	C. 1/4" MNPT Nipple	3. No Gauge			
	0-250 PSIG	(400 psi/28 bar)	003 (1/8" Tube fitting)	D. 1/4" FNPT Port	5. He Leak Cert. (Outboard)			
	0-500 PSIG	(1000 psi/70 bar)		E. 1/4" Tube Fitting				
				F. 1/8" Tube Fitting				
				G. 1/4" Hose barb x 1/4" MNPT				
				H. 1/8" Hose barb x 1/4" MNPT				

NOTE: Regulators with delivery pressure above 15 PSIG should not be used with acetylene.



## FLOW DATA

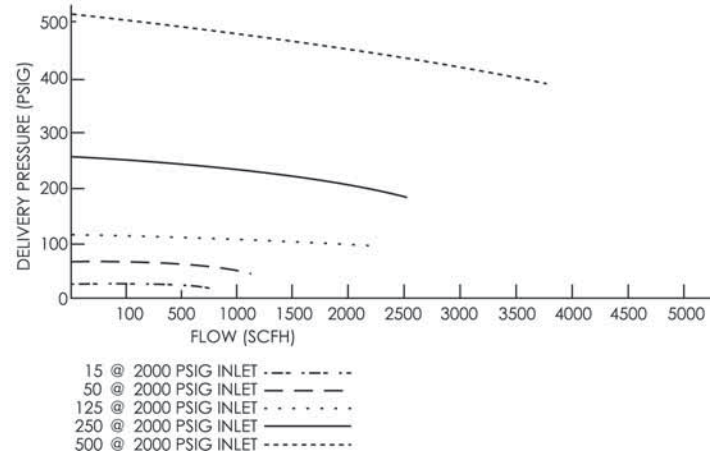
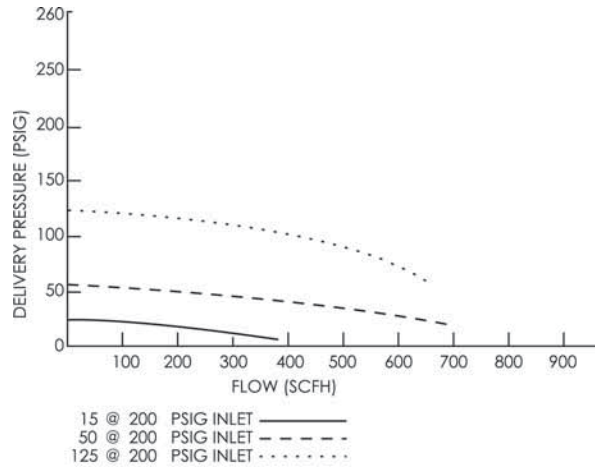

## SPECIFICATIONS

- Cv: .08
- Pressure Regulation: 1.8 PSIG/100 PSIG
- Weight: 2.68 lbs.

## DIMENSIONS

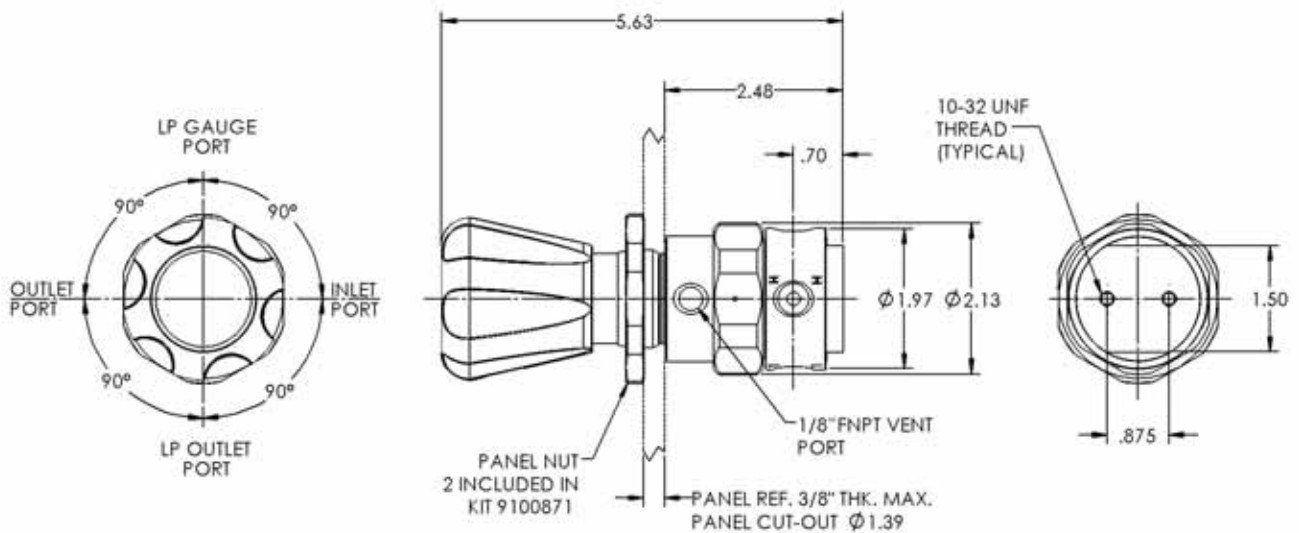

# HP 701

High Purity - Chrome Plated Brass Regulator



Model HP 701-125-580-BE shown

Model HP 701 is a chrome plated single stage cylinder regulator with a stainless steel diaphragm for general laboratory use. The HP 701 can be used when a slight pressure rise from full to empty cylinder can be tolerated. The HP 701 is suitable for:

- Non-corrosive gases
- Purging
- Pressure testing
- Blanketing

**Recommended for gas purity up to Grade 5.0 (99.999).**

## FEATURES

- 2 - 1/8" 302 stainless steel diaphragm eliminates contamination from diffusion or outgassing
- One-piece encapsulated seat design to protect seat from particulate contamination
- Chrome plated bonnet, body and fittings
- 2" chrome plated dual scale gauges (psi/bar)
- External relief valve standard
- Designed to 1 x 10<sup>-8</sup> cc/sec. inboard helium leak rate to maintain gas purity levels
- Maximum inlet pressure 3000 PSIG except for models with CGA 300 and 510 and equipped with 400 PSIG inlet gauge

## RELATED OPTIONS

Wall mounting bracket P/N: 9101242



## MATERIALS

Body	Chrome Plated Brass
Bonnet	Chrome Plated Die Cast
Diaphragm	302 Stainless Steel
Nozzle	Brass
Seat	PTFE Teflon
Seals	PTFE Teflon
Filter	Nickel-Plated Sintered Bronze - 10 Micron
Seat Return Spring	PH-17 Stainless Steel
Adjusting Knob	ABS Plastic

**SHIPS  
24  
TO  
48hr**

## HP 701 ORDERING INFORMATION

HP 701	-	XXX	-	XXX	-	XXXX	-	XXX
MODEL NO.	DELIVERY PRESSURE		CGA / INLET FITTING	ACCESSORIES		OPTIONS		
	DELIVERY	(OUTLET GAUGE)						
HP 701	0-15 PSIG	(30" Hg Vac-30 psi/2 bar)	280	350	A) 1/4" MNPT Needle Valve	1) Without Relief Valve		
	0-50 PSIG	(30" Hg Vac-100 psi/7 bar)	296	500	B) 1/4" FNPT Diaph. Valve	3) No Gauges		
	0-125 PSIG	(30" Hg Vac-200 psi/14 bar)	300	510	C) 1/4" MNPT Nipple	6) 400 psi inlet gauge		
	0-250 PSIG	(400 psi/28 bar)	320	540	D) 1/4" FNPT Port	<b>Gas Service Must be Specified</b>		
			326	555	E) 1/4" Tube Fitting			
			346	580	F) 1/8" Tube Fitting			
			000 (1/4" FNPT)	590	G) 1/4" Hose barb x 1/4" MNPT			
			001 (1/4" MNPT)		H) 1/8" Hose barb x 1/4" MNPT			
					I) 1/4" Hose barb x 1/4" FNPT			
					J) 1/4" FNPT Needle Valve			
					K) Single Regulator Alarm			
					L) SG 910 BR Protocol w/36" Pigtail			





## FLOW DATA

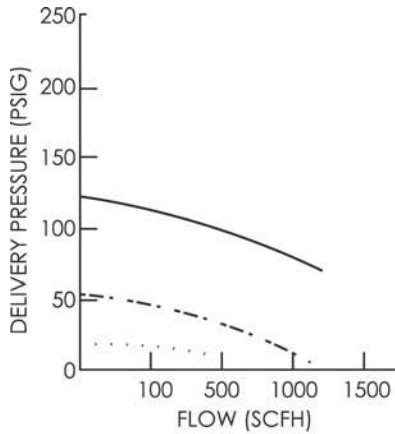

15 @ 200 PSIG INLET .....  
 50 @ 200 PSIG INLET - - - - -  
 125 @ 200 PSIG INLET —————

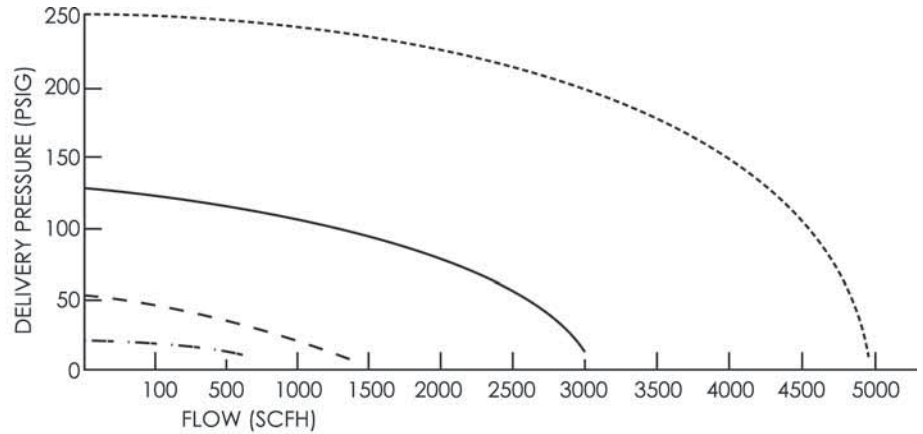

15 @ 2000 PSIG INLET ······  
 50 @ 2000 PSIG INLET - - - - -  
 125 @ 2000 PSIG INLET —————  
 250 @ 2000 PSIG INLET - - - - -

## SPECIFICATIONS

- $C_v$ : .17
- Pressure Regulation: 1.3 PSIG/100 PSIG
- Weight: 3.5 Lbs.

## DIMENSIONS

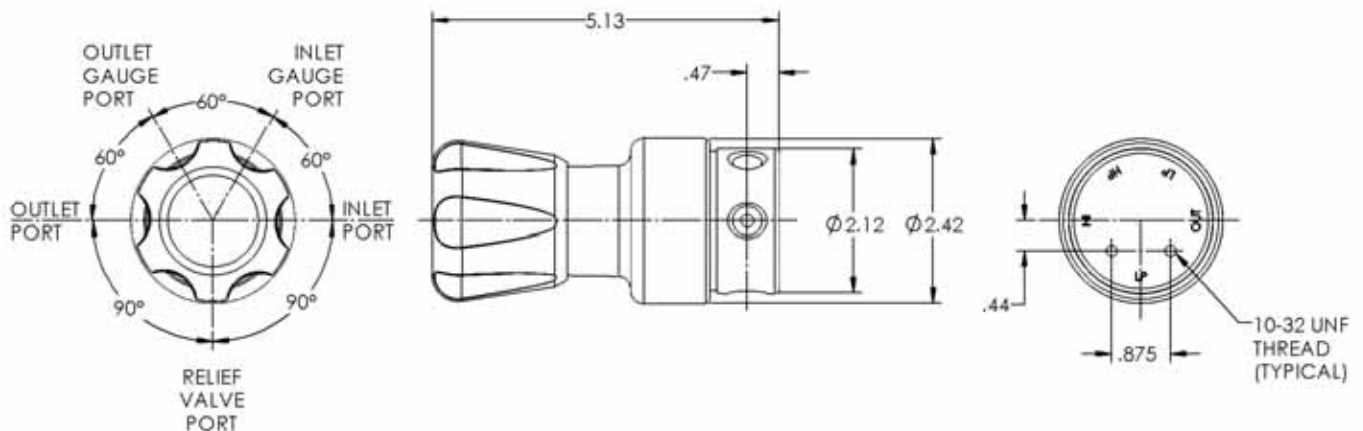

# HP 702

High Purity - Chrome Plated Brass Regulator



Model HP 702-125-580-B shown

## MATERIALS

Body	Chrome Plated Brass	<b>SHIPS 24 TO 48hr</b>
Bonnets	Chrome Plated Die Cast	
Diaphragms	302 Stainless Steel	
Nozzles	Brass	
Seat	PTFE Teflon	
Seals	PTFE Teflon	
Filter	Nickel-Plated Sintered Bronze - 10 Micron	
Seat Return Spring	PH-17 Stainless Steel	
Adjusting Knob	ABS Plastic	

Model HP 702 is a chrome plated brass two stage cylinder regulator with a stainless steel diaphragm for general laboratory use. The HP 702 provides constant delivery pressure from full to near empty cylinder conditions. The HP 702 is suitable for:

- Non-corrosive gases
- Purging
- Pressure testing
- Blanketing
- Incubators

**Recommended for gas purity up to Grade 5.0 (99.999).**

## FEATURES

- 2 1/8" 302 stainless steel diaphragm eliminates contamination from diffusion or outgassing
- One-piece encapsulated seat design to protect seat from particulate contamination
- Chrome plated bonnet, body and fittings
- 2" chrome plated dual scale gauges (psi/bar)
- External relief valve standard
- Designed to 1 x 10<sup>-8</sup> cc/sec. inboard helium leak rate to maintain gas purity levels
- Maximum inlet 3000 PSIG except for models with CGA 300 and 510 equipped with 400 PSIG inlet gauge

## HP 702 ORDERING INFORMATION

HP 702	-	XXX	-	XXX	-	XXXX	-	XX
DELIVERY PRESSURE								
MODEL NO.	DELIVERY	(OUTLET GAUGE)	CGA INLET FITTING		ACCESSORIES		OPTIONS	
HP 702	0-15 PSIG	(30" Hg Vac-30 psi/2 bar)	000 (1/4" FNPT)	350	A. 1/4" MNPT Needle Valve	1. Without Relief Valve		
	0-50 PSIG	(30" Hg Vac-100 psi/7 bar)	001 (1/4" MNPT)	500	B. 1/4" FNPT Diaph. Valve	3. No Gauges		
	0-125 PSIG	(30" Hg Vac-200 psi/14 bar)	280	510	C. 1/4" MNPT Nipple			
	0-250 PSIG	(400 psi/28 bar)	296	540	D. 1/4" FNPT Port			
			300	555	E. 1/4" Tube Fitting			
			326	580	F. 1/8" Tube Fitting			
		346	590	G. 1/4" Hose barb x 1/4" MNPT				
				H. 1/8" Hose barb x 1/4" MNPT				
				I. 1/4" Hose barb x 1/4" FNPT				
				J. 1/4" FNPT Needle Valve				
				K. Single Regulator Alarm				
				L. SG 910 BR Regulator Mounting Station				



## FLOW DATA

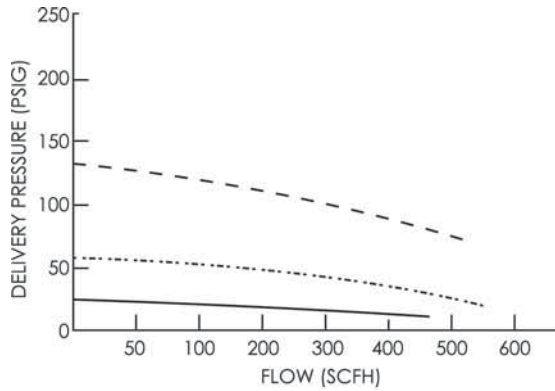

15 @ 200 PSIG INLET ———  
 50 @ 200 PSIG INLET - - - - -  
 125 @ 200 PSIG INLET - - - - -

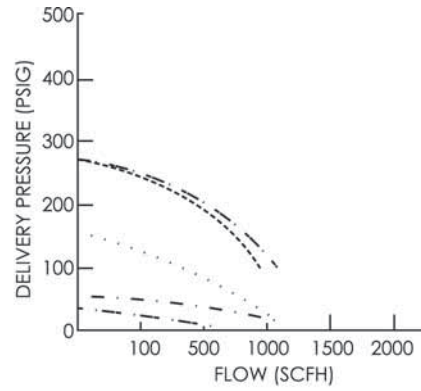

15 @ 2000 PSIG INLET - - - - -  
 50 @ 2000 PSIG INLET - - - - -  
 125 @ 2000 PSIG INLET - - - - -  
 250 @ 350 PSIG INLET - - - - -  
 250 @ 2000 PSIG INLET - - - - -

## SPECIFICATIONS

- $C_v$ : .15
- Pressure Regulation: 0.04 PSIG/100 PSIG
- Weight: 4.48 lbs.

## DIMENSIONS

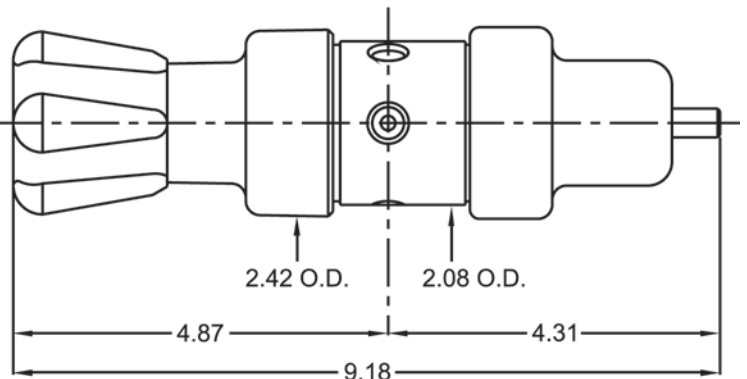
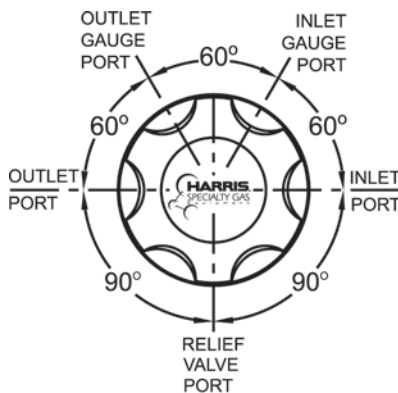

# HP 703

High Purity - Chrome Plated Brass Regulator



Model HP 703 is a chrome plated brass single stage pipeline regulator with a stainless steel diaphragm for general laboratory use. The HP 703 is suitable for:

- Non-corrosive gases
- Purging
- Pressure testing
- Blanketing

**Recommended for gas purity up to Grade 5.0 (99.999).**

## FEATURES

- 2 - 1/8" 302 stainless steel diaphragm eliminates contamination from diffusion or outgassing
- One-piece encapsulated seat design to protect seat from particulate contamination
- Chrome plated bonnet, body and fittings
- 2" chrome plated dual scale gauge (psi/bar)
- External relief valve standard
- Designed to  $1 \times 10^{-8}$  cc/sec. inboard helium leak rate to maintain gas purity levels
- Max inlet 3000 PSIG

## RELATED OPTIONS

Wall mounting bracket P/N: 9101242



Model HP 703-125-000-D shown

## MATERIALS

Body	Chrome Plated Brass
Bonnet	Chrome Plated Die Cast
Diaphragm	302 Stainless Steel
Nozzle	Brass
Seat	PTFE Teflon
Seals	PTFE Teflon
Filter	Nickel-Plated Sintered Bronze - 10 Micron
Seat Return Spring	PH-17 Stainless Steel
Adjusting Knob	ABS Plastic

**SHIPS  
24  
TO  
48hr**

## HP 703 ORDERING INFORMATION

MODEL NO.	DELIVERY PRESSURE		INLET FITTING	ACCESSORIES	OPTIONS
HP 703	DELIVERY	(OUTLET GAUGE)			
	0-15 PSIG	(30" Hg Vac-30 psi/2 bar)	000 (1/4" FNPT)	A. 1/4" MNPT Needle Valve	1. Without Relief Valve
	0-50 PSIG	(30" Hg Vac-100 psi/7 bar)	001 (1/4" MNPT)	B. 1/4" FNPT Diaph. Valve	3. No Gauge
	0-125 PSIG	(30" Hg Vac-200 psi/14 bar)	002 (1/4" Tube Fitting)	C. 1/4" MNPT Nipple	
	0-250 PSIG	(400 psi/28 bar)	003 (1/8" Tube Fitting)	D. 1/4" FNPT Port	
			004 (1/4" Hose barb x 1/4" MNPT)	E. 1/4" Tube Fitting	
			005 (1/8" Hose barb x 1/4" MNPT)	F. 1/8" Tube Fitting	
				G. 1/4" Hose barb x 1/4" MNPT	
				H. 1/8" Hose barb x 1/4" MNPT	
				I. 1/4" Hose barb x 1/4" FNPT	
				J. 1/4" FNPT Needle Valve	

NOTE: Regulators with delivery pressure above 15 PSIG should not be used with acetylene.





## FLOW DATA

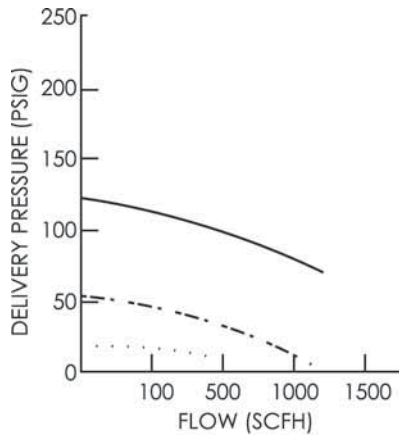

15 @ 200 PSIG INLET .....  
50 @ 200 PSIG INLET - - - -  
125 @ 200 PSIG INLET \_\_\_\_\_

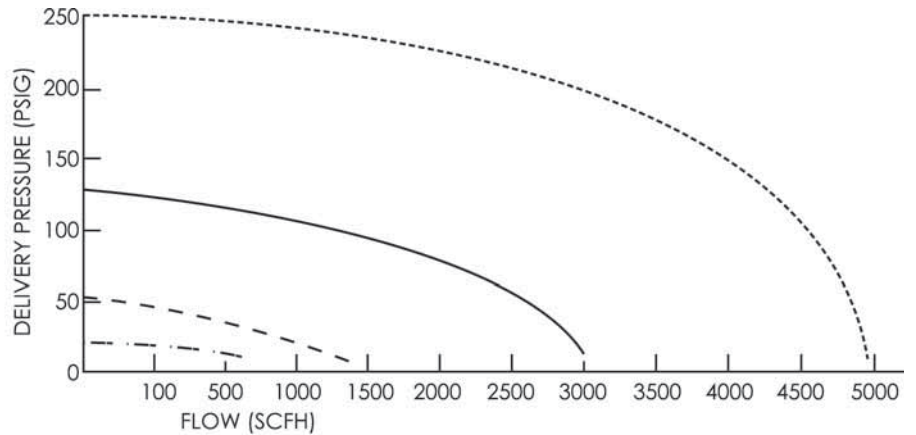

15 @ 2000 PSIG INLET - · - · -  
50 @ 2000 PSIG INLET - - - -  
125 @ 2000 PSIG INLET \_\_\_\_\_  
250 @ 2000 PSIG INLET ······

## SPECIFICATIONS

- $C_v$ : .17
- Pressure Regulation: 1.8 PSIG/100 PSIG
- Weight: 2.92 lbs.

## DIMENSIONS

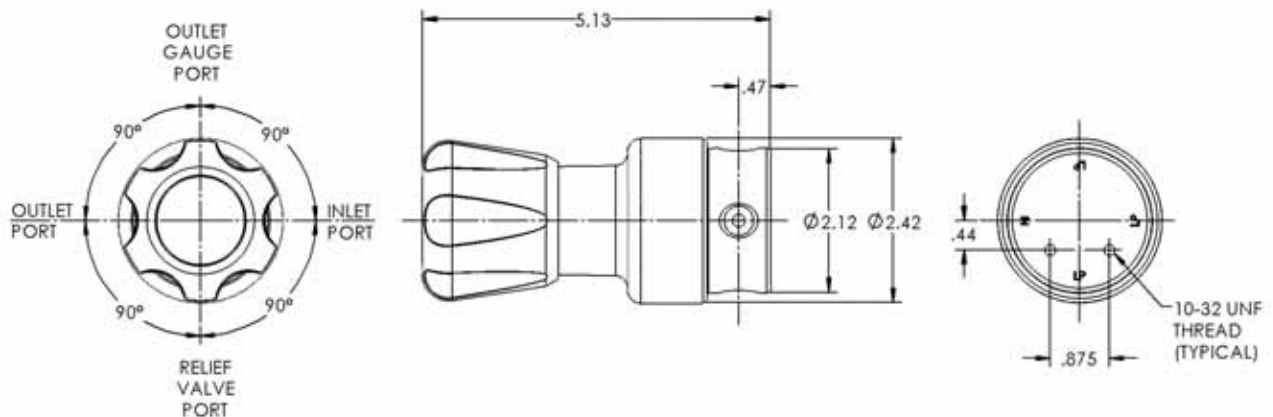

# GP 401

General Purpose - Brass Regulator



Model GP 401-125-580-C

## MATERIALS

Body	Brass / Chrome Plated
Bonnet	Painted Die Cast / Chrome Plated
Diaphragm	Neoprene
Nozzle	Brass
Seat	PTFE Teflon
Filter	Nickel-Plated Sintered Bronze - 10 Micron
Seat Return Spring	PH 17-7 Stainless Steel
Adjusting Knob	ABS Plastic
Outlet	1/4" MNPT Brass

**SHIPS  
24  
TO  
48hr**

Model GP 401 is a brass single stage regulator with a neoprene diaphragm for general purpose laboratory applications where a slight rise in delivery pressure from a full to near empty cylinder can be tolerated. The GP 401 is not recommended for high purity applications which may be sensitive to contamination due to elastomeric components. The Model GP 401 is suitable for:

- Non-corrosive industrial grade gases
- Purging
- Pressure testing
- Gas blanketing

## FEATURES

- 0-15, 0-50, 0-125 and 0-250 PSIG delivery pressure
- Neoprene diaphragm for greater sensitivity
- One-piece encapsulated seat design, to protect the seat from particulate contamination
- Tamper-proof, self reseating internal safety valve
- 2" dual scale brass gauges (psi/kPa)
- Conforms to CGA E-4 standard for gas pressure regulators

## RELATED OPTIONS

Wall mounting bracket P/N: 9101242



## GP 401 ORDERING INFORMATION

GP 401	-	XXX	-	XXX	-	XX	-	XX
DELIVERY PRESSURE								
MODEL NO.	DELIVERY	(OUTLET GAUGE)	CGA/INLET FITTING			ACCESSORIES		OPTIONS
GP 401	0-15 PSIG	(30" Hg Vac-30 psi/2 bar)	000 (1/4" FNPT)	350		A. 1/4" MNPT Needle Valve		1. No gauges
GP 401C (chrome-plated)	0-50 PSIG	(30" Hg Vac-100 psi/7 bar)	001 (1/4" MNPT)	500		B. 1/4" FNPT Diaph. Valve		2. 400 psi inlet gauge
	0-125 PSIG	(30" Hg Vac-200 psi/14 bar)	320	510		C. 1/4" MNPT Nipple		<b>Gas Service Must be Specified</b>
	0-250 PSIG	(400 psi/28 bar)	326	540		D. 1/4" FNPT Port		
			346	555		E. 1/4" Tube Fitting		
				580		F. 1/8" Tube Fitting		
				590		G. 1/4" MNPT Hose Barb		
						H. 1/8" MNPT Hose Barb		
						I. 1/4" FNPT Hose Barb		
						J. 1/4" FNPT Needle Valve		
						K. SG 910BR Protocol Station w/36" Pigtail		
						L. Industrial Hose Connection "B"		



## FLOW DATA

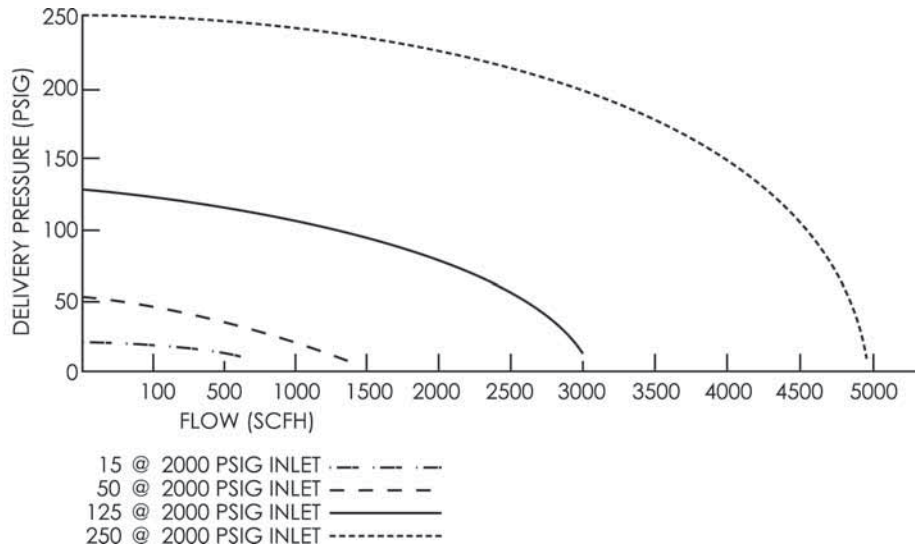
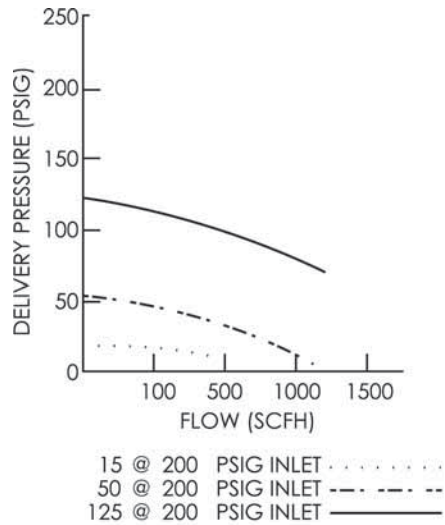

## SPECIFICATIONS

- Cv: .17
- Pressure Regulation: 1.3 PSIG/100 PSIG
- Weight: 3.5 lbs.

## DIMENSIONS

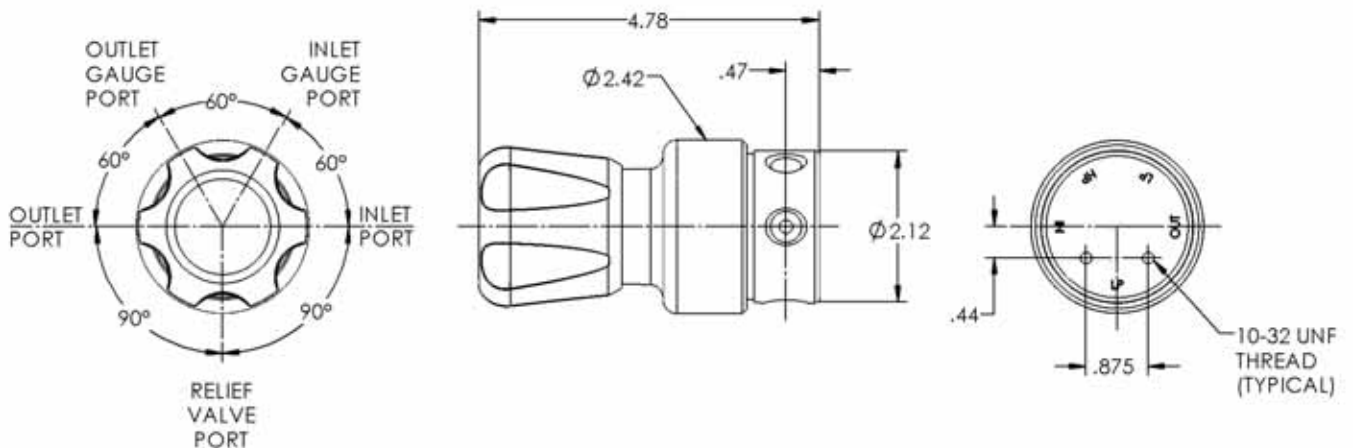

# GP 402

General Purpose - Brass Regulator



Model GP 402-050-580 shown

## MATERIALS

Body	Brass / Chrome Plated	<b>SHIPS 24 TO 48hr</b>
Bonnet	Painted Die Cast / Chrome Plated	
Diaphragm	Neoprene	
Nozzle	Brass	
Seat	PTFE Teflon	
Filter	Nickel-Plated Sintered Bronze - 10 Micron	
Seat Return Spring	PH 17-7 Stainless Steel	
Adjusting Knob	ABS Plastic	
Outlet	1/4" MNPT Brass	

Model GP 402 is a brass two stage regulator with neoprene diaphragms for general purpose laboratory applications. The GP 402 maintains a constant delivery pressure from full to near empty cylinder conditions. The GP 402 is not recommended for high purity applications which may be sensitive to contamination due to elastomeric components. The Model GP 402 is suitable for:

- Non-corrosive industrial grade gases
- Purging
- Pressure testing
- Gas shielding

## FEATURES

- 0-15, 0-50, 0-125 and 0-250 PSIG delivery pressure
- Neoprene diaphragms for greater sensitivity
- One-piece encapsulated seat design to protect the seat from particulate contamination
- Tamper-proof, self reseating internal safety valve
- 2" dual scale brass gauges (psi/kPa)
- Conforms to CGA E-4 standard for gas pressure regulators

## GP 402 ORDERING INFORMATION

GP 402	-	XXX	-	XXX	-	XX	-	XX
MODEL NO.	DELIVERY PRESSURE		CGA/INLET FITTING		ACCESSORIES	OPTIONS		
	DELIVERY	(OUTLET GAUGE)						
GP 402	0-15 PSIG	[30" Hg Vac-30 psi/2 bar]	000 [1/4" FNPT]	350	A. 1/4" MNPT Needle Valve	1. No gauges		
GP 402C (Chrome-plated)	0-50 PSIG	[30" Hg Vac-100 psi/7 bar]	001 [1/4" MNPT]	500	B. 1/4" FNPT Diaph. Valve	2. 400 psi inlet gauge <b>Gas Service Must be Specified</b>		
	0-125 PSIG	[30" Hg Vac-200 psi/14 bar]	300	510	C. 1/4" MNPT Nipple			
	0-250 PSIG	[400 psi/28 bar]	320	540	D. 1/4" FNPT Port			
			326	555	E. 1/4" Tube Fitting			
		346	580	F. 1/8" Tube Fitting	G. 1/4" MNPT Hose Barb			
			590		H. 1/8" MNPT Hose Barb			
					I. 1/4" FNPT Hose Barb			
					J. 1/4" FNPT Needle Valve			
					K. SG 910BR Protocol Station w/36" Pigtail			
					L. Industrial Hose Connection "B"			



## FLOW DATA

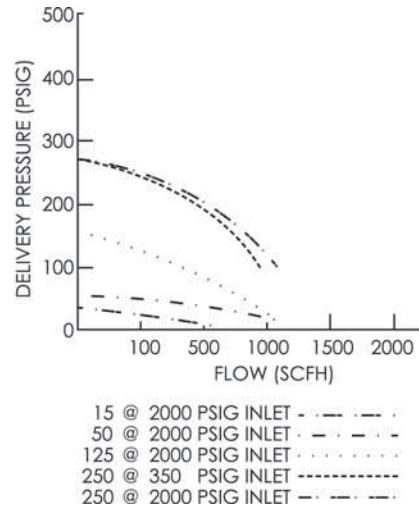
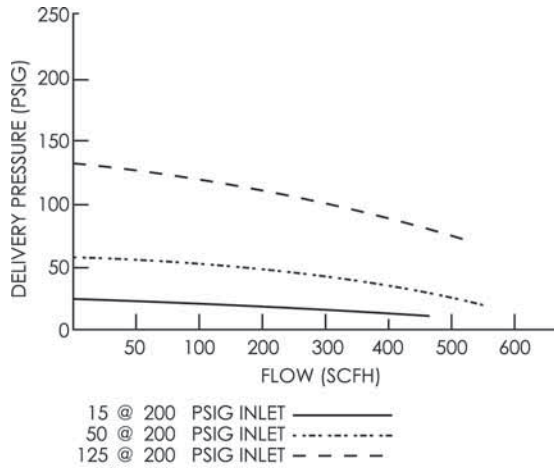

## SPECIFICATIONS

- Cv: .15
- Pressure Regulation: .04 PSIG/100 PSIG
- Weight: 4.48 lbs.

## DIMENSIONS

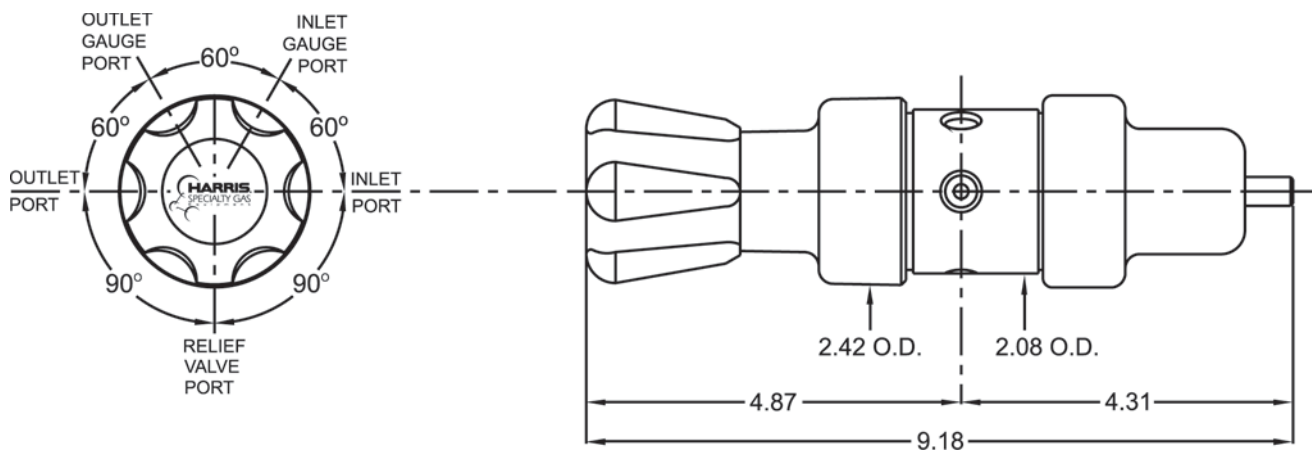



# GP 403

General Purpose - Brass Regulator



Model GP 403-125-000-D shown

Model GP 403 is a brass single stage pipeline regulator with a neoprene diaphragm for general purpose laboratory applications. The GP 403 is not recommended for high purity applications which may be sensitive to contamination due to elastomeric components.

The GP 403 is suitable for:

- Non-corrosive industrial grade gases
- Purging
- Pressure testing
- Blanketing

## FEATURES

- 0-15, 0-50, 0-125 and 0-250 PSIG delivery pressure
- Neoprene diaphragm for greater sensitivity
- One-piece encapsulated seat design to protect the seat from particulate contamination
- Tamper-proof, self reseating internal safety valve
- 2" dual scale brass gauge (psi/kPa)
- Conforms to CGA E-4 standard for gas pressure regulators

## MATERIALS

Body	Brass
Bonnet	Painted Die Cast
Diaphragm	Neoprene
Nozzle	Brass
Seat	PTFE Teflon
Filter	Nickel-Plated Sintered Bronze - 10 Micron
Seat Return Spring	PH 17-7 Stainless Steel
Adjusting Knob	ABS Plastic
Inlet/Outlet	1/4" FNPT

**SHIPS  
24  
TO  
48hr**

## RELATED OPTIONS

Wall mounting bracket P/N: 9101242



## GP 403 ORDERING INFORMATION

GP 403	-	XXX	-	XXX	-	XX	-	XX
MODEL NO.	DELIVERY PRESSURE		CGA/INLET FITTING	ACCESSORIES	OPTIONS			
	DELIVERY	[OUTLET GAUGE]						
GP 403	0-15 PSIG	(30" Hg Vac-30 psi/2 bar)	000 - 1/4" FNPT x 1/4" FNPT	A. 1/4" MNPT Needle Valve	1. No gauges			
	0-50 PSIG	(30" Hg Vac-100 psi/7 bar)	001 - 1/4" MNPT x 1/4" MNPT	B. 1/4" FNPT Diaph. Valve				
	0-125 PSIG	(30" Hg Vac-200 psi/14 bar)	002 (1/4" Tube Fitting)	C. 1/4" MNPT Nipple				
	0-250 PSIG	(400 psi/28 bar)	003 (1/8" Tube Fitting)	D. 1/4" FNPT Port				
			004 (1/4" Hose barb x 1/4" MNPT)	E. 1/4" Tube Fitting				
			005 (1/8" Hose barb x 1/4" MNPT)	F. 1/8" Tube Fitting				
				G. 1/4" MNPT Hose Barb				
				H. 1/8" MNPT Hose Barb				



## FLOW DATA

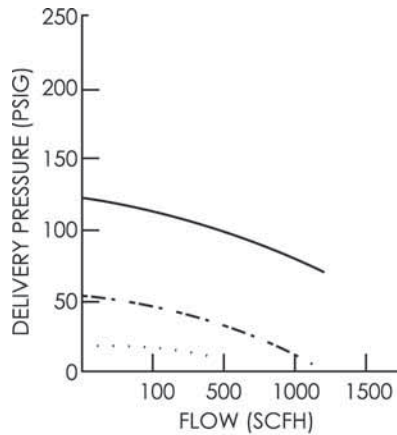

15 @ 200 PSIG INLET .....  
50 @ 200 PSIG INLET - - - - -  
125 @ 200 PSIG INLET \_\_\_\_\_

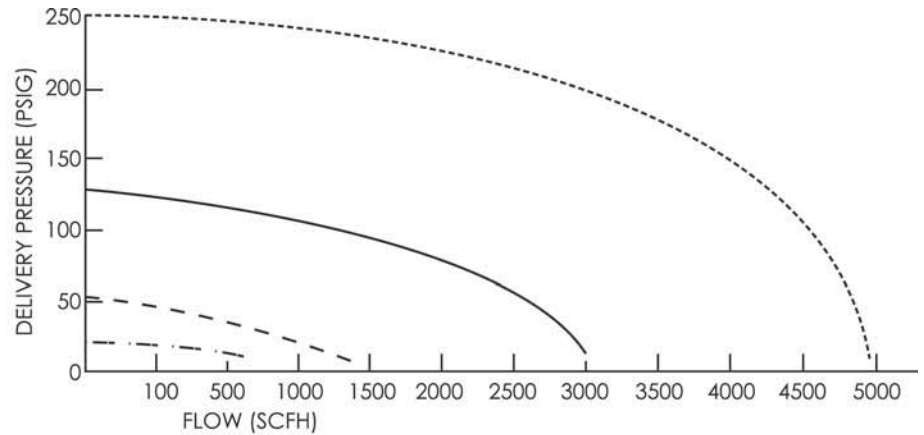

15 @ 2000 PSIG INLET · · · · ·  
50 @ 2000 PSIG INLET - - - - -  
125 @ 2000 PSIG INLET \_\_\_\_\_  
250 @ 2000 PSIG INLET - - - - -

## SPECIFICATIONS

- Cv: .17
- Pressure Regulation: 1.8 PSIG/100 PSIG
- Weight: 2.92 lbs.

## DIMENSIONS

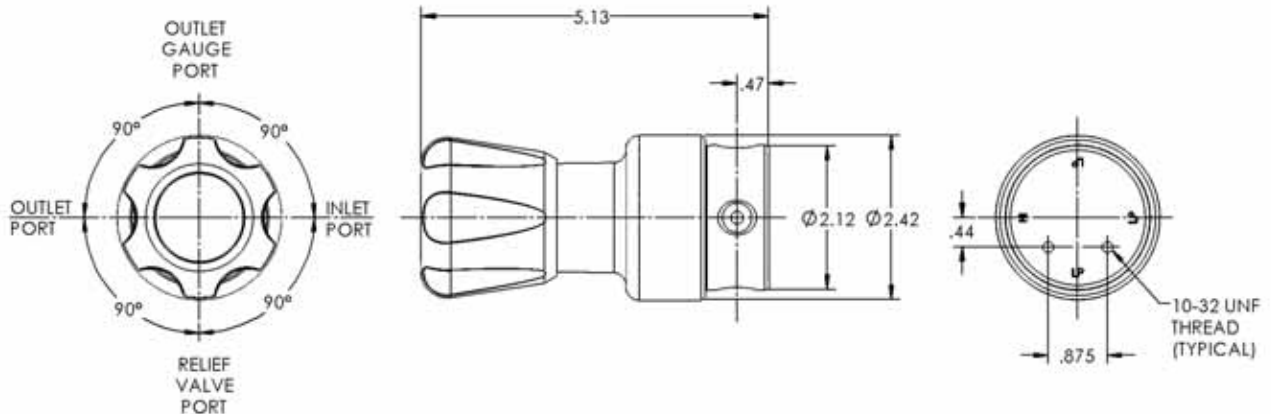

# HP 704

High Purity - Lecture Bottle Regulator

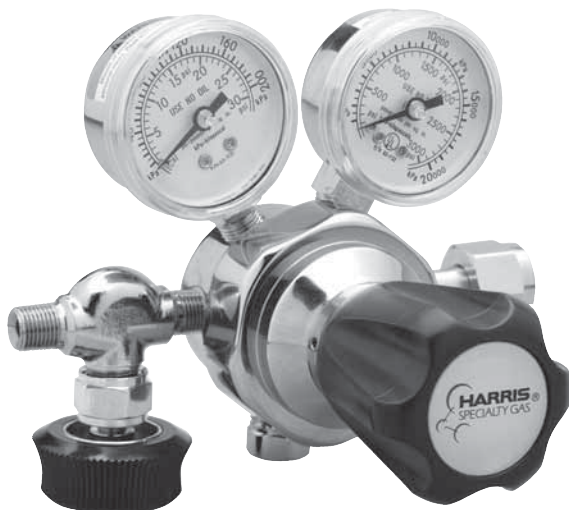

Model HP 704 is a chrome plated brass single stage regulator for non-corrosive gases for lecture bottles. The Model HP 704 is suitable for:

- High Purity
- Non-corrosive gases
- EPA protocol gases
- Calibration gases
- Sampling gases

## FEATURES

- Diffusion resistant stainless steel diaphragm
- One-piece encapsulated seat design to protect seat from particulate contamination
- 1 1/2" gauges
- Conforms to CGA E-4 standard for gas pressure regulators
- Relief valve

## RELATED OPTIONS

Laboratory Lecture Bottle Holders



Shown with model G 710  
Lecture bottle holder  
P/N: 4302678



Shown with model G 700  
Lecture bottle holder  
P/N: 4302677



Model HP 704-015-170-A shown

## MATERIALS

Body	Chrome Plated Brass Barstock
Bonnet	Chrome Plated Brass
Diaphragm	316L Stainless Steel
Nozzle	Brass
Seat	PTFE Teflon
Filter	Nickel-Plated Sintered Bronze - 10 Micron
Seat Return Spring	PH-17 Stainless Steel
Adjusting Knob	ABS Plastic

SHIPS  
24  
TO  
48hr

## HP 704 ORDERING INFORMATION

HP 704 - XXX - XXX - X - XXXX

MODEL NO.	DELIVERY PRESSURE		CGA/INLET FITTING	ACCESSORIES	OPTIONS
	DELIVERY	(OUTLET GAUGE)			
HP 704	0-15 PSIG	(0-30 PSI)	170	A. 1/8" MNPT Needle Valve (P/N: 9100928)	1. Without Relief Valve
	0-100 PSIG	(0-150 PSI)	180	B. 1/8" FNPT Port	2. He. Leak Cert (inboard)
			000 (1/8" FNPT)		3. Without Gauges
					4. He. Leak Cert (outboard)



## FLOW DATA

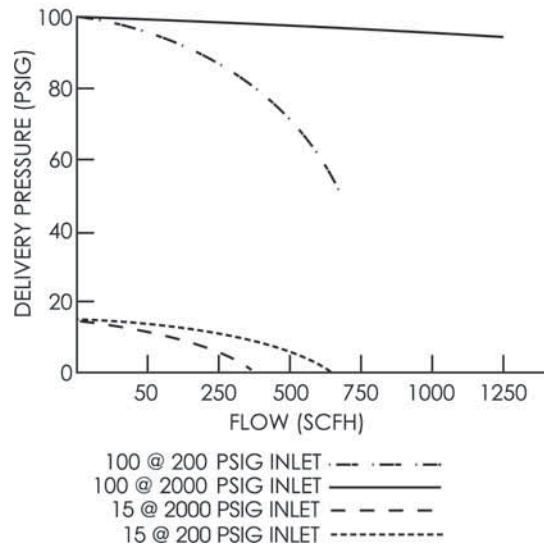

## SPECIFICATIONS

- $C_v$ : .08 w/valve
- Pressure Regulation: .4 PSIG/100 PSIG
- Weight: 2.0 lbs.

## DIMENSIONS

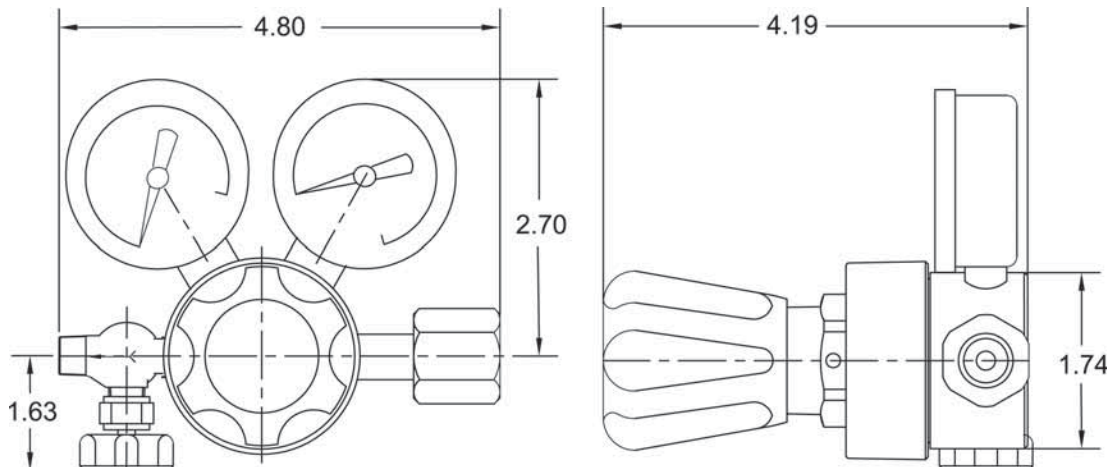

# GP 404

General Purpose - Lecture Bottle Regulator



Model GP 404-100-170-A shown

Model GP 404 is a brass single stage regulator for non-corrosive gases for lecture bottles. The Model GP 404 is suitable for:

- Non-corrosive gases
- EPA protocol gases
- Calibration gases
- Sampling gases

## FEATURES

- Neoprene diaphragm for greater sensitivity
- One-piece encapsulated seat design to protect seat from particulate contamination
- 1 1/2" dual scale gauges (psi/kPa)
- Conforms to CGA E-4 standard for gas pressure regulators

## RELATED OPTIONS

Laboratory Lecture Bottle Holders



Shown with model G 710  
Lecture bottle holder  
P/N: 4302678



Shown with model G 700  
Lecture bottle holder  
P/N: 4302677

## MATERIALS

Body	Brass Barstock
Bonnet	Painted Die Cast
Diaphragm	Neoprene
Nozzle	Brass
Seat	PTFE Teflon
Filter	Nickel-Plated Sintered Bronze - 10 Micron
Seat Return Spring	PH-17 Stainless Steel
Adjusting Screw	Brass

**SHIPS  
24  
TO  
48hr**

## GP 404 ORDERING INFORMATION

GP 404	-	XXX	-	XXX	-	X
MODEL NO.	DELIVERY PRESSURE		CGA/INLET FITTING	ACCESSORIES		
	DELIVERY	(OUTLET GAUGE)				
GP 404	0-100 PSIG	(0-150 psi/1000 kPa)	170 180 000 (1/8" FNPT)	A. 1/8" MNPT Needle Valve (P/N: 9100415) B. 1/8" FNPT Port C. 1/8" MNPT Nipple		





## FLOW DATA

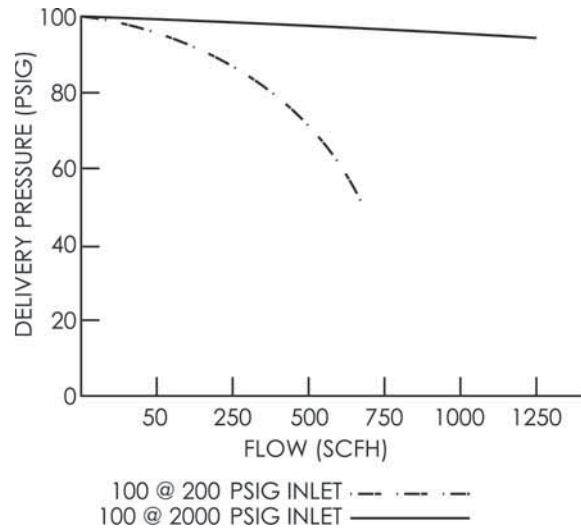

## SPECIFICATIONS

- $C_v$ : .08 w/valve
- Pressure Regulation: .4 PSIG/100 PSIG
- Weight: 1.8 lbs.

## DIMENSIONS

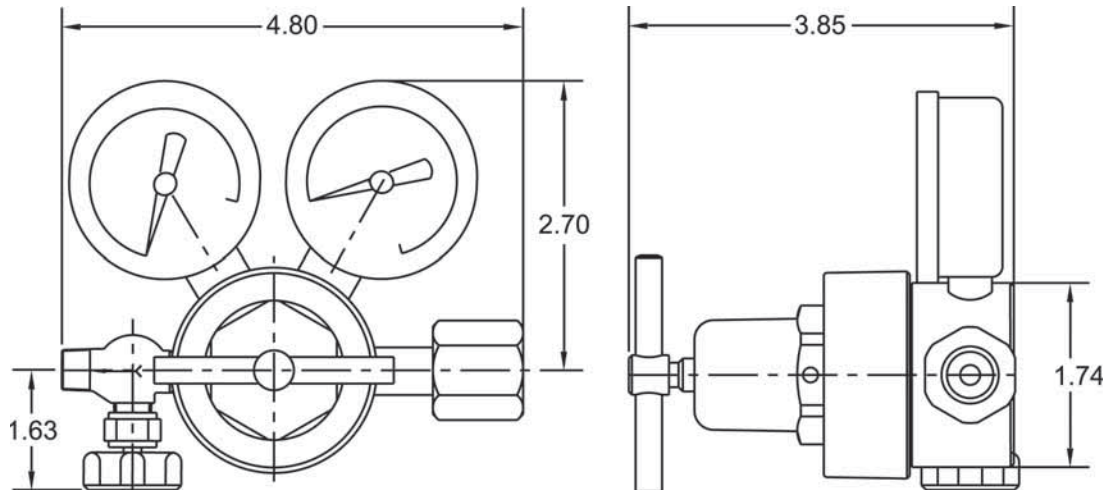

# HP 405

Liquid Cylinder Regulator



Model HP 405-350-580-A shown

Model HP 405 is a chrome plated brass single stage regulator for gaseous withdrawal from liquid cylinders. The HP 405 can also be used on high pressure cylinders and for general pipeline applications. The Model HP 405 is suitable for:

- Laser assist gas
- Purging
- Pressure testing
- Blanketing
- Gas withdrawal from liquid cylinders

## FEATURES

- 0-125, 0-350 and 0-500 PSIG delivery pressure
- One-piece encapsulated seat design to protect seat from particulate contamination
- Chrome plated bonnet, body and fittings
- 2" chrome plated dual scale gauge (psi/bar)
- Conforms to CGA E-4 standard for gas pressure regulators
- Maximum inlet 3000 PSIG
- Tamper-proof, self reseating internal relief valve

## MATERIALS

Body	Chrome Plated Brass
Bonnet	Chrome Plated Brass
Diaphragm	302 Stainless Steel
Nozzle	Brass
Seat	PTFE Teflon
Seals	PTFE Teflon
Filter	Nickel-Plated Sintered Bronze - 10 Micron
Seat Return Spring	PH 17-7 Stainless Steel
Adjusting Screw	Brass

**SHIPS  
24  
TO  
48hr**

## HP 405 ORDERING INFORMATION

HP 405	-	XXX	-	XXX	-	X
DELIVERY PRESSURE						
MODEL NO.	DELIVERY	(OUTLET GAUGE)	CGA/INLET FITTING		ACCESSORIES	
HP 405	0-125 PSIG	(0-200 psi/14 bar)	320		A. 1/4" Tube Fitting (Stainless Steel)	
	0-350 PSIG	(0-400 psi/28 bar)	540		B. 1/4" FNPT Port	
	0-500 PSIG	(0-1000 psi/70 bar)	580			
		000 (1/4" FNPT)				
		001 (1/4" MNPT)				



## FLOW DATA

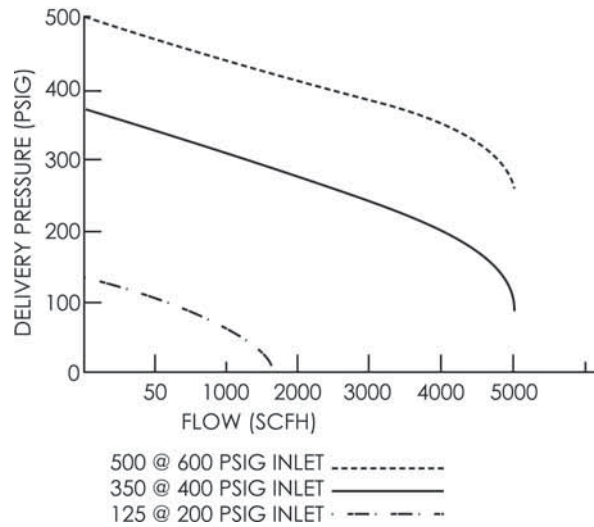

## SPECIFICATIONS

- $C_v$ : .37
- Pressure Regulation: .9 PSIG/100 PSIG
- Weight: 3.1lbs.

## DIMENSIONS

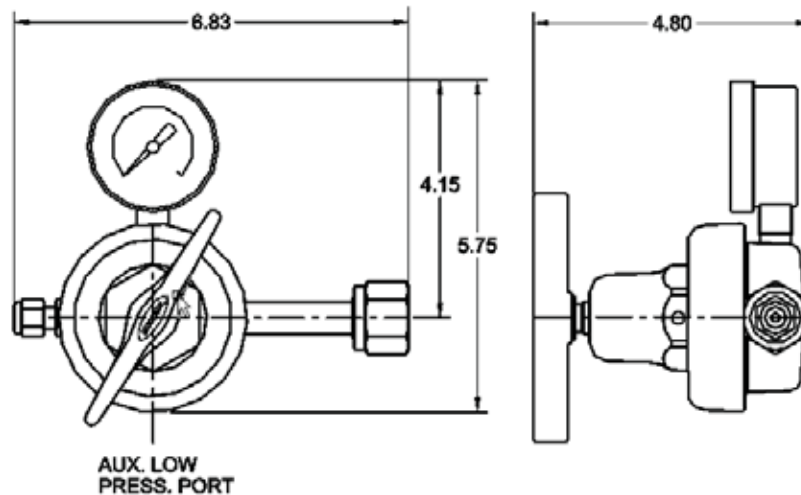

# LIQUID CYLINDER PERFORMANCE DATA



## SPECIFICATIONS

	SIZE	160	160	180	180	200	200	230	230	265	265
	PRESSURE	MP	HP	MP	HP	MP	HP	MP	HP	MP	HP
<b>Capacity</b>											
Liquid[Gross]	(liters)	176	176	196	196	209	209	240	240	276	276
Liquid[Net]	(liters)	165	165	185	185	196	196	230	230	265	265
Gas[N <sub>2</sub> ]*	ft <sup>3</sup> /Nm <sup>3</sup>	3685/97	3464/91	4099/108	3864/102	4375/115	4072/108	5024/132	4734/124	5769/152	5438/143
Gas[O <sub>2</sub> ]*	ft <sup>3</sup> /Nm <sup>3</sup>	4577/120	4348/114	5096/134	4843/127	5435/143	5048/133	6244/164	5930/156	7186/189	6811/179
Gas[Ar]*	ft <sup>3</sup> /Nm <sup>3</sup>	4448/117	4226/111	4961/130	4709/124	5290/139	4932/130	6073/160	5763/151	6982/183	6634/174
Gas[CO <sub>2</sub> ]*	ft <sup>3</sup> /Nm <sup>3</sup>	--	3382/89	--	3766/99	--	4011/105	--	4614/121	--	5305/132
Gas[N <sub>2</sub> O]*	ft <sup>3</sup> /Nm <sup>3</sup>	--	3207/84	--	3574/94	--	3810/100	--	4378/115	--	5034/132

## Performance

NER[N <sub>2</sub> ]	% per day	2	2	1.9	1.9	1.85	1.85	1.8	1.8	2	2
NER[O <sub>2</sub> -Ar]	% per day	1.4	1.4	1.3	1.3	1.2	1.2	1.2	1.2	1.4	1.4
NER[CO <sub>2</sub> -N <sub>2</sub> O]	% per day	--	0.5	--	0.5	--	0.5	--	0.5	--	0.5
Gas Flow [N <sub>2</sub> , CO <sub>2</sub> , Ar]	ft <sup>3</sup> /hr	350/9.2	350/9.2	350/9.2	350/9.2	400/10.5	400/10.5	400/10.5	400/10.5	400/10.5	400/10.5
Gas Flow [CO <sub>2</sub> , N <sub>2</sub> O]	ft <sup>3</sup> /hr	--	110/2.9	--	110/2.9	--	110/2.9	--	110/2.9	--	110/2.9

## Dimensions & Pressure Ratings

Relief Valve Setting	psig/bar	230/16	350/24	230/16	350/24	230/16	350/24	230/16	350/24	230/16	350/24
DOT/CTC Rating		4L200	4L292	4L200	4L292	4L200	4L292	4L200	4L292	4L200	4L292
Diameter	in/cm	20/50.8	20/50.8	20/50.8	20/50.8	20/50.8	20/50.8	26/66.0	26/66.0	26/66.0	26/66.0
Height	in/cm	59.6/151.3	59.6/151.3	63.5/161.3	63.5/161.3	65.8/167.1	65.8/167.1	52.9/131.9	52.9/131.9	57.8/146.8	57.8/149.8
Empty Weight	lb/kg	250/113.4	280/126.9	260/117.9	300/136.1	280/126.9	320/145.1	300/136.1	340/154.2	340/154.2	360/163.6
Full Weight [N <sub>2</sub> ]	lb/kg	517/234	531/241	557/253	580/263	597/271	618/280	664/301	683/310	758/344	754/343
[O <sub>2</sub> ]	lb/kg	629/285	640/290	682/309	701/318	730/331	747/339	817/370	831/377	935/424	924/420
[Ar]	lb/kg	710/322	717/325	773/351	787/357	827/375	839/380	928/421	936/424	1062/481	1046/475
[CO <sub>2</sub> ]	lb/kg	--	667/303	--	731/331	--	779/353	--	868/393	--	967/439
[N <sub>2</sub> O]	lb/kg	--	647/293	--	709/321	--	756/343	--	841/381	--	936/425

\*AT RELIEF VALVE SETTINGS

## NOMENCLATURE

1. Gas Use Valves - For gas withdrawal
2. Fill/Liquid Valves - For filling or fluid withdrawal operations
3. Pressure Control Valves - To isolate (on/off) the pressure control regulator
4. Vent Valves - to vent valve
5. Combination Pressure Control Regulator - To automatically control \ operating pressure
6. Pressure Gauges - Indicates cylinder pressure
7. Rupture Disk
8. Relief Valves
9. Liquid Level Gauge - To approximate the liquid contents of the liquid cylinder

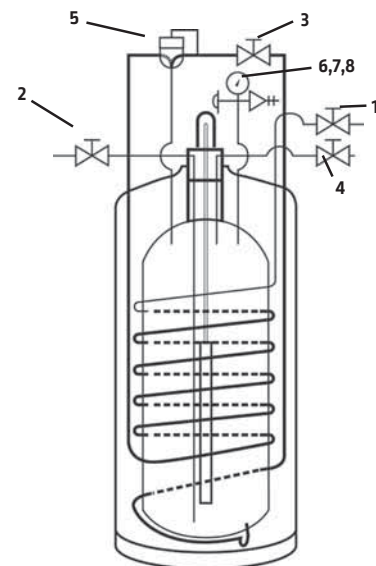

Data provided by CHART\* Industries

# WHY DOES A REGULATOR FREEZE UP?



## CO<sub>2</sub> REGULATOR FREEZE UP

Under certain conditions, users of carbon dioxide gas (from high pressure cylinders), experience “freeze-up” problems on valves, regulators and other compressed gas equipment. The term “freeze up” refers to a pressure regulator becoming clogged with dry ice, snow or crystals, which restrict the flow of gas through the regulator or other pressure control valve. The following explains this phenomenon in an effort to help users avoid problems in CO<sub>2</sub> distribution systems.

## WHY DOES A REGULATOR FREEZE UP?

When high pressure CO<sub>2</sub> gas expands through a regulator seat or other flow control orifice, it can be seen downstream of the orifice on the low pressure side of the regulator as a mixture of gas with solid (snow) or liquid CO<sub>2</sub>. If the downstream pressure is below 60 PSIG, the mixture is gas and snow, above 60 PSIG, the mixture is gas and liquid.

The amount of solid (snow) or liquid can vary from <1%, at inlet pressures under 800 PSIG when the cylinder is cool, to more than 20% under severe freeze up condition when the pressure is above 1100 PSIG resulting from a warm cylinder. Contrary to what one might expect, the most severe freeze-up conditions with CO<sub>2</sub> exists on warm days when a full cylinder is at 90°F or higher and the cylinder pressure is at least 1100 PSI. At normal room temperature, and full cylinder pressures of 700-900 PSI, the problem exists, but not as severe as under the conditions above.

Solid CO<sub>2</sub> cannot form at pressures above 60 PSIG. It occurs when the gas undergoes the pressure drop at the regulator valve from inlet pressure to a delivery pressure below 60 PSIG, emerging as a mixture of gaseous and solid CO<sub>2</sub> at a temperature in the range of -70°F at 60 PSIG to -100°F at the lower pressures. Under the most severe freeze-up conditions, a significant percentage of the mixture can be solid, requiring about 200 watts of heat /100 scfh of CO<sub>2</sub> to vaporize the solid and raise the gas to room temperature.

## WHY USE A HEATED REGULATOR?

Unheated regulators, operating at delivery pressures below 60 PSIG, are subject to classic freeze up with solid CO<sub>2</sub>. The CO<sub>2</sub> snow and dry ice particles may pass through a regulator if the outlet is wide open. If an orifice or flow control valve is used, a filter is needed to prevent the solid CO<sub>2</sub> particles from clogging the orifice. This can result in the low pressure chamber of the regulator becoming completely filled with solid CO<sub>2</sub>. The severity of the problem depends upon the flowrate of CO<sub>2</sub>, the inlet conditions, the duty cycle (percentage of time that the gas is flowing) and the physical size of the regulator.



Harris Model HP 705 Electrically Heated Regulator

Unheated regulators, even if they avoid the classic problem of freeze up, cannot avoid the refrigerant effect of CO<sub>2</sub>. When the pressure drops at the regulator valve, the CO<sub>2</sub> temperature drops sharply to the levels stated above, and at normal flow rates, frost can cover the entire regulator and extend to the downstream system. This frost is a result of the moisture in the air freezing and accumulating on the exterior surface. It is not related to the CO<sub>2</sub> effects described here and typically have no effect on the performance of the valve.

## THE SOLUTION

Heated regulators can relieve or eliminate freeze-up problems. The Harris Model HP 705 has 200 watts of heat to provide a continuous 100 scfh of CO<sub>2</sub> under the most severe freeze-up conditions and higher flowrates under normal (intermittent) conditions. The regulators are two-stage, to include the advantages of the two-stage regulators discussed above. The first stage cavity serves as a boiler to vaporize CO<sub>2</sub> liquid and eliminate or minimize any CO<sub>2</sub> solids in the second stage. The second stage chamber is then available to heat the CO<sub>2</sub> vapor before it reaches the outlet.





# HP 705

Electrically Heated - Chrome Plated Brass Barstock



Model HP 705-125-320-A1 shown

## MATERIALS

Body	Chrome Plated Brass Barstock
Bonnet	Chrome Plated Die Cast
Diaphragm	302 Stainless Steel
Nozzle	Brass
Seat	PTFE Teflon
Seals	Buna-N
Filter	Nickel-Plated Sintered Bronze - 10 Micron
Seat Return Spring	Stainless Steel
Adjusting Knob	ABS Plastic

**SHIPS  
24  
TO  
48hr**

Model HP 705 is an electrically heated dual stage regulator used for non corrosive liquefied gases with up to 3000 PSIG inlet pressure. The Model HP 705 is suitable for:

- Chemical storage blanketing
- CO2 incubators
- Inert gas purging
- Ph control

**Recommended for non-corrosive, liquefied gases or mixtures subject to freeze up.**

## FEATURES

- Stainless steel diaphragm
- First stage brass piston sensor
- One piece encapsulated seat design includes a 10 micron sintered filter to protect the seat from particulate contamination
- 2 1/2" chrome plated dual scale gauges (psi/bar)
- Maximum inlet 3000 PSIG
- 200 Watt electric heater
- 120 or 240 volt
- Continuous flow up to 100 SCFH CO2
- All electrical components are UL Listed

## HP 705 ORDERING INFORMATION

HP 705	-	XXX	-	XXX	-	XX	-	X
MODEL NO.	DELIVERY PRESSURE	(OUTLET GAUGE)	CGA/INLET FITTING	SPECIFY ACCESSORIES				VOLTAGE
HP 705	125 PSIG	(200 psi/14 bar)	320	A.	1/4" MNPT Needle Valve	1. 120 VAC		
	200	(400 psi/28bar)	326	B.	1/4" FNPT Diaph. Valve	2. 240 VAC		
			580	C.	1/4" FNPT Port			
	000 (No Inlet)			000 (No Inlet)	D.	1/4" MNPT Nipple		
					E.	1/4" Tube Fitting		
				F.	1/8" Tube Fitting			
				G.	1/4" MNPT Hose Barb			
				H.	1/8" MNPT Hose Barb			
				J)	Inert fitting - 9000794			



## FLOW DATA

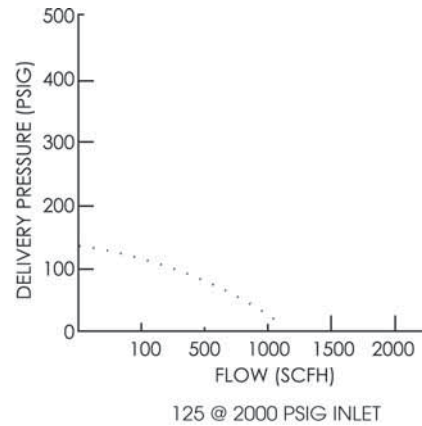
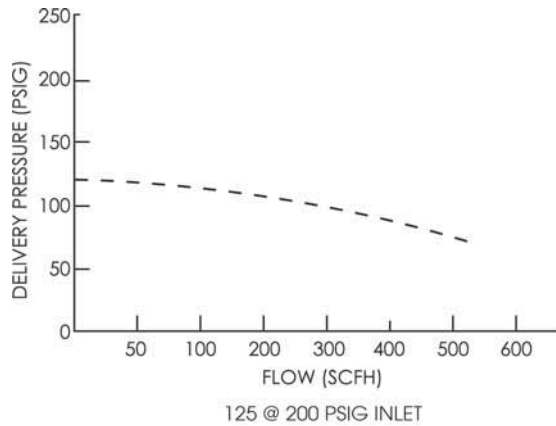

## SPECIFICATIONS

- Cv: .15
- Pressure Regulation: 0.9 PSIG/100 PSIG
- Weight: 6.8 Lbs.

## DIMENSIONS

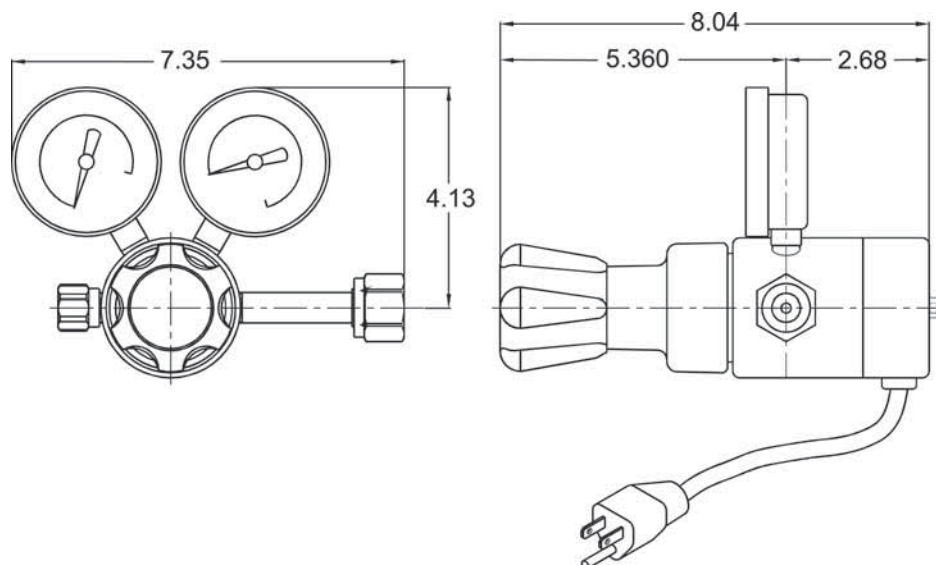

# HP 8700

Ultra High Pressure Regulator



The Model HP 8700 is a single stage high pressure regulator that is designed to operate on high pressure cylinders up to 7500 PSIG. The Model HP 8700 is suitable for:

- High pressure testing
- Charging accumulators
- Pressurizing aircraft struts

## FEATURES

- 0-800, 0-1500, 2500, 3000, 4500 and 6000 PSIG delivery pressures available
- One piece encapsulated valve design with PCTFE seats and an internal filter
- Ergonomic knob for improved grip
- 1/4" NPT outlet with stainless steel 1/4" tube fitting
- 2 1/2" dual scale gauges (psi/bar)
- Conforms to CGA E-4 standard for gas pressure regulators
- Models with the following CGA inlet connections are self venting - 346, 347, 580, 590, 677, 680

## RELATED OPTIONS

Panel Mount Nut P/N: 9100887



Model 8700-6000-677 shown

## MATERIALS

Body	Brass Barstock
Bonnet	Brass Barstock
Diaphragm	All models Urethane, except O2 which is Neoprene
Nozzle	Brass
Seat	PCTFE (Kel-F™)
Filter	Nickel-Plated Sintered Bronze - 10 Micron
Seat Return Spring	PH 17-7 Stainless Steel
Adjusting Knob	ABS Plastic
Outlet	1/4" Stainless Steel Tube Fitting

## HP 8700 ORDERING INFORMATION

**\* Ships in 24 to 48 hours**

PART NO.	MODEL NO.	GAS	MAX. INLET PSIG	DELIVERY PRESSURE RANGE PSIG	DELIVERY PRESSURE GAUGE PSIG	SUPPLY PRESSURE GAUGE PSIG
3200270	8700-800-346	Medical Air	3000	0-800	1,000	4,000
3200311	8700-2500-346		3000	0-2500	3,000	4,000
3200312	8700-1500-347		5,500	0-1500	3,000	6,000
3200314	8700-3000-347		5,500	0-3000	4,000	6,000
3200315	8700-4500-347		5,500	0-4500	6,000	6,000
3200271	8700-800-350	Hydrogen, Methane	3000	0-800	1,000	4,000
3200302*	8700-1500-350		3,000	0-1500	3,000	4,000
3200303	8700-2500-350		3,000	0-2500	4,000	4,000
3200316	8700-1500-695		5,500	0-1500	3,000	6,000
3200318	8700-3000-695		5,500	0-3000	4,000	6,000
3200319	8700-4500-695	5,500	0-4500	6,000	6,000	
3200273	8700-800-590	Industrial Air	3000	0-800	1,000	4,000
3200304*	8700-1500-590		3,000	0-1500	3,000	4,000
3200305*	8700-2500-590		3,000	0-2500	4,000	4,000
3200306*	8700-1500-540	Oxygen	3,000	0-1500	3,000	4,000
3200307*	8700-2500-540		3,000	0-2500	4,000	4,000
3200308	8700-1500-540-Surge Guard		3,000	0-1500	3,000	4,000
3200309	8700-2500-540-Surge Guard	3,000	0-2500	4,000	4,000	
3200272	8700-800-580	Nitrogen, Argon, Helium	3000	0-800	1,000	4,000
3200300*	8700-1500-580		3,000	0-1500	3,000	3,000
3200301*	8700-2500-580		3,000	0-2500	4,000	4,000
3200320	8700-1500-677		7,500	0-1500	3,000	10,000
3200321*	8700-3000-677		7,500	0-3000	4,000	10,000
3200322*	8700-4500-677		7,500	0-4500	6,000	10,000
3200323*	8700-6000-677		7,500	0-6000	10,000	10,000
3200324	8700-1500-680		5,500	0-1500	3,000	6,000
3200326*	8700-3000-680		5,500	0-3000	4,000	6,000
3200327*	8700-4500-680		5,500	0-4500	6,000	6,000



## FLOW DATA

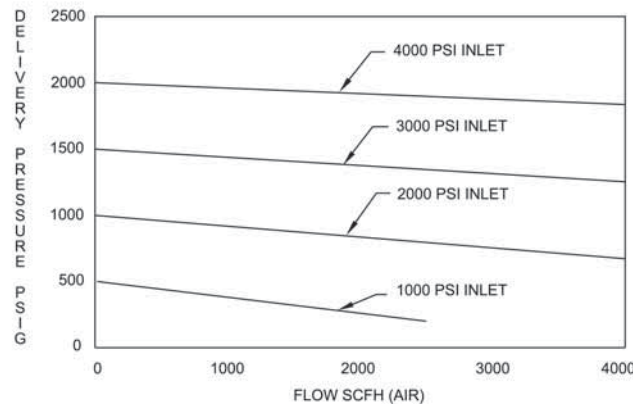

## SPECIFICATIONS

### NON-VENTING MODELS

- Regulator Weight: 5.8 lbs.
- Pressure Rise: 3.3 PSIG per 100 PSIG
- $C_v$ : .08

### SELF-VENTING MODELS

- Regulator Weight: 7.0 lbs.
- Pressure Rise: 3.3 PSIG per 100 PSIG
- $C_v$ : .08

## DIMENSIONS

### NON-VENTING MODELS

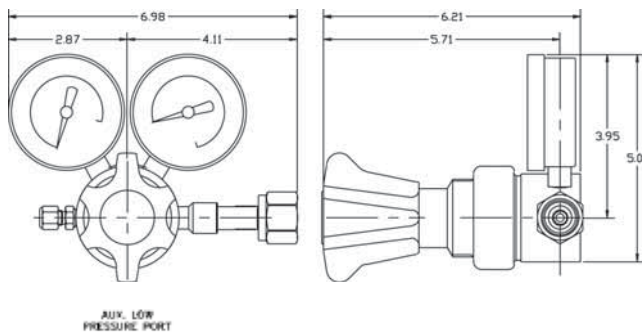

### SELF-VENTING MODELS

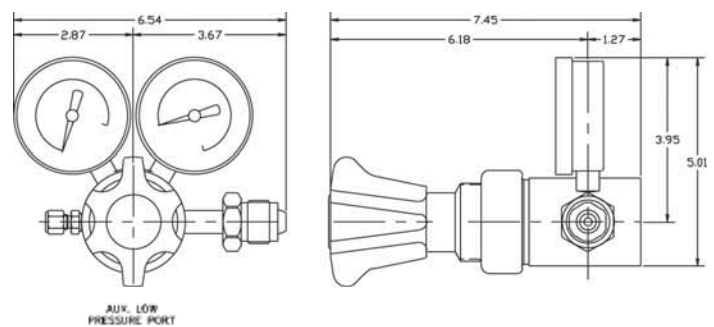

# HP 8700SS

Ultra High Pressure Regulator



Model HP 8700SS-4500-680 shown

## MATERIALS

Body	300 Series Stainless Steel
Bonnet	Chrome Plated Brass Barstock
Diaphragm	Urethane*
Nozzle	316L Stainless Steel
Seat	PCTFE
Filter	10 Micron Stainless Steel
Seat	Return Spring
Adjusting Knob	ABS Plastic
Outlet	1/4" Stainless Steel Tube Fitting

The Model HP 8700SS is a single stage high pressure regulator that is designed to deliver high outlet pressures when used on high pressure cylinders up to 7500 PSIG. The Model HP 8700SS is suitable for:

- High pressure testing
- Charging accumulators
- Pressurizing aircraft struts

## FEATURES

- 0-1500, 2500, 3000, 4500 and 6000 PSIG delivery pressures available
- One piece encapsulated valve design with PCTFE seats and an internal filter
- Ergonomic knob for improved grip
- 1/4" NPT outlet with stainless steel 1/4" tube fitting
- 2 - 1/2" Stainless Steel dual scale gauges (psi/bar)
- Conforms to CGA E-4 standard for gas pressure regulators

Models with the following CGA inlet connections are self venting - 346, 347, 580, 590, 677, 680

## RELATED OPTIONS

Brass Panel Mount Nut P/N: 9100887

## HP 8700SS ORDERING INFORMATION

PART NO.	MODEL NO.	GAS	MAX. INLET PSIG	DELIVERY PRESSURE RANGE PSIG	DELIVERY PRESSURE GAUGE PSIG	SUPPLY PRESSURE GAUGE PSIG
3200394	8700SS-1500-346		3000	0-1500	2,000	4,000
3200395	8700SS-2500-346		3000	0-2500	4,000	4,000
3200396	8700SS-1500-347	Medical Air	5,500	0-1500	2,000	6,000
3200397	8700SS-3000-347	(Self-Relieving)	5,500	0-3000	4,000	6,000
3200398	8700SS-4500-347		5,500	0-4500	6,000	6,000
3200705	8700SS-1500-350		3,000	0-1500	2,000	4,000
3200714	8700SS-2500-350		3,000	0-2500	4,000	4,000
3200712	8700SS-1500-695	Hydrogen, Methane	5,500	0-1500	2,000	6,000
3200721	8700SS-3000-695		5,500	0-3000	4,000	6,000
3200725	8700SS-4500-695		5,500	0-4500	6,000	6,000
3200408	8700SS-1500-590	Industrial Air	3,000	0-1500	2,000	4,000
3200409	8700SS-2500-590	(Self-Relieving)	3,000	0-2500	4,000	4,000
3200706	8700SS-1500-540		3,000	0-1500	2,000	4,000
3200715	8700SS-2500-540	Oxygen	3,000	0-2500	4,000	4,000
3200399	8700SS-1500-580		3,000	0-1500	2,000	3,000
3200400	8700SS-2500-580		3,000	0-2500	4,000	4,000
3200404	8700SS-1500-677		7,500	0-1500	2,000	10,000
3200405	8700SS-3000-677		7,500	0-3000	4,000	10,000
3200406	8700SS-4500-677	Nitrogen, Argon, Helium	7,500	0-4500	6,000	10,000
3200407	8700SS-6000-677	(Self-Relieving)	7,500	0-6000	10,000	10,000
3200401	8700SS-1500-680		5,500	0-1500	2,000	6,000
3200402	8700SS-3000-680		5,500	0-3000	4,000	6,000
3200403	8700SS-4500-680		5,500	0-4500	6,000	6,000
3200700	8700SS-1500-000		3000	0-1500	2,000	4000
3200699	8700SS-2500-000	1/4" NPT Female	3000	0-2500	4,000	4000
3200701	8700SS-3000-000	Inlet & Outlet	6000	0-3000	4,000	6000
3200702	8700SS-4500-000	Non-Relieving	6000	0-4500	6,000	6000
3200703	8700SS-6000-000		10,000	0-6000	10,000	10,000





## FLOW DATA

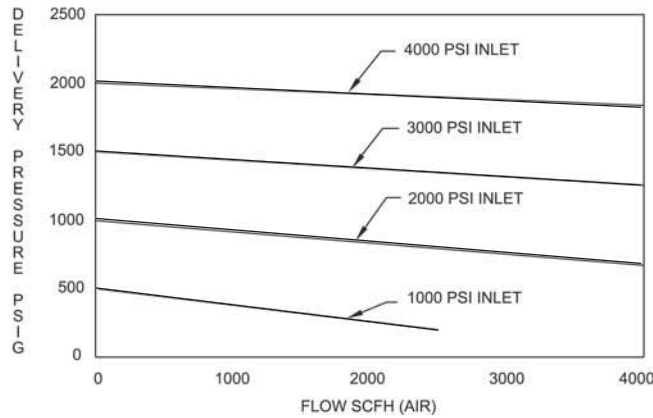

## SPECIFICATIONS

### NON-VENTING MODELS

- Regulator Weight: 5.8 lbs.
- Pressure Rise: 3.3 PSIG per 100 PSIG
- Cv: .08

### SELF-VENTING MODELS

- Regulator Weight: 7.0 lbs.
- Pressure Rise: 3.3 PSIG per 100 PSIG
- Cv: .08

## DIMENSIONS

### NON-VENTING MODELS

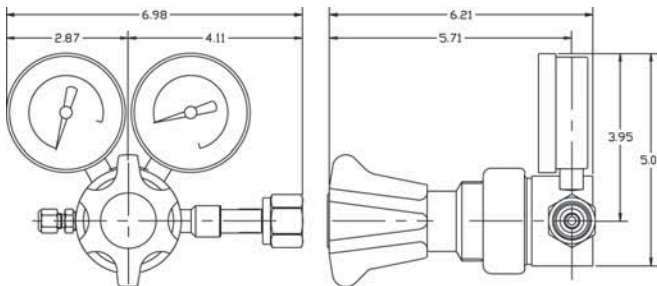

### SELF-VENTING MODELS

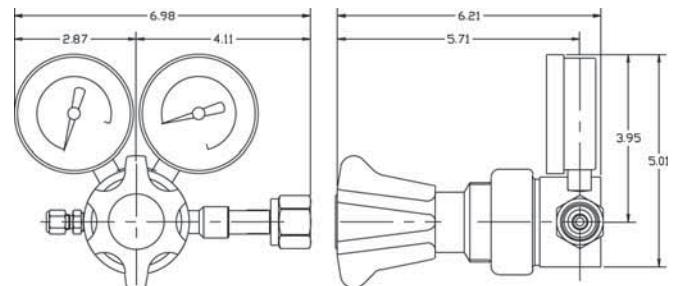

# HP 701EN

Single Stage Electroless Nickel Plated Regulator



Model shown is 701EN-125-330-FA

## MATERIALS

Body	Electroless Nickel Plated Brass
Bonnet	Electroless Nickel Plated Brass
Diaphragm	316L Stainless Steel
Seat	PTFE Teflon
Seals	PTFE Teflon
Filter	Sintered Stainless Steel - 10 Micron

The Model HP 701EN is a single stage regulator with an electroless nickel plated brass body for primary pressure control of corrosive and acid forming gases or gas mixtures. Typical applications include:

- Hydrogen Chloride
- Hydrogen Bromide
- Hydrogen Sulfide
- Boron Trichloride
- Dichlorosilane
- Chlorine

Harris strongly recommends the use of a 316 SS cross purge assembly for highly corrosive and acid forming gases. The use of a cross purge will eliminate moisture which will result in acid corrosion inside the regulator

## FEATURES

- 2" 316L SS diaphragm eliminates contamination from diffusion or outgassing
- One piece encapsulated seat design includes a 10 micron sintered filter to protect from contamination
- 2" 316 SS gauges (psi/bar)
- Up to 250 PSIG outlet pressures available
- Designed to 1.0 x 10<sup>-8</sup> cc/sec He leak rate to maintain gas purity
- 316 SS gauges and fittings

## RELATED OPTIONS

Wall mounting bracket P/N: 9101242



## HP 701EN Ordering Information

HP 701EN	-	XXX	-	XXX	-	XX	-	XXXX
MODEL NO.	DELIVERY PRESSURE		CGA INLET FITTING	ACCESSORIES		OPTIONS		
	DELIVERY	[OUTLET GAUGE]						
HP 701EN	0-15 PSIG	(30" Hg Vac-30 PSIG)	240	A. 1/4" FNPT Diaph Valve	1. He Leak Cert (Inboard)			
	0-50 PSIG	(30" Hg Vac-100 PSIG)	330	B. 1/4" MNPT Nipple	2. No Gauge			
	0-125 PSIG	(30" Hg Vac-200 PSIG)	660	C. 1/4" FNPT Port	3. w/Relief Valve			
	0-250 PSIG	(30" Hg Vac-400 PSIG)	705	D. 1/4" Tube Fitting	4. He leak Cert (Outboard)			
			000 (1/4" FNPT)	E. 1/8" Tube Fitting	5. 400 psi inlet gauge			
			001 (1/4" MNPT)	F. Inlet Cross Purge	6. 1000 psi inlet gauge			
				G. Single Regulator Alarm	<b>Gas Service Must be Specified</b>			
				H. SG910SS Mounting Station*				
				*Not available with cross purge				



## FLOW DATA

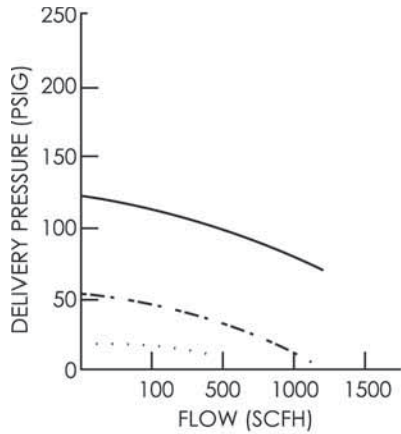

15 @ 200 PSIG INLET .....  
 50 @ 200 PSIG INLET - - - - -  
 125 @ 200 PSIG INLET \_\_\_\_\_

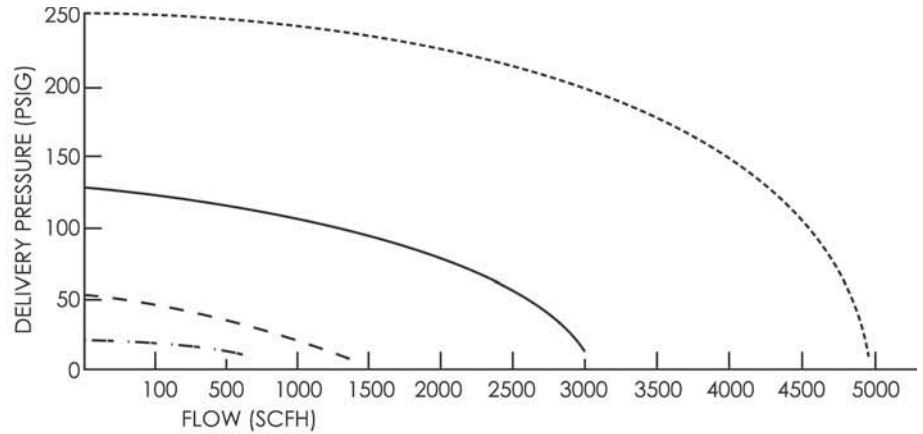

15 @ 2000 PSIG INLET - . . . . .  
 50 @ 2000 PSIG INLET - - - - -  
 125 @ 2000 PSIG INLET \_\_\_\_\_  
 250 @ 2000 PSIG INLET .....

## SPECIFICATIONS

- Cv: .17
- Pressure Regulation: 1.3 PSIG/100 PSIG
- Weight: 3.5 Lbs.

## DIMENSIONS

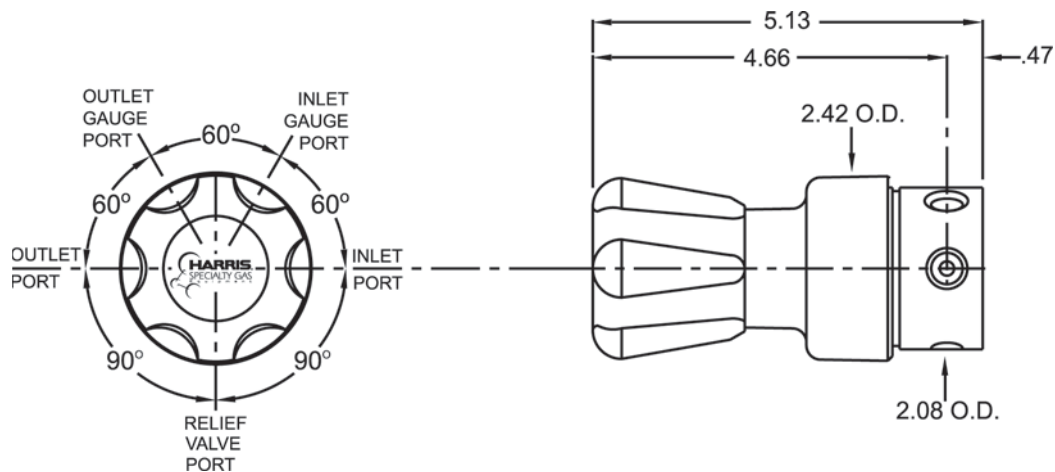

# HP721AL

Single Stage Aluminum Body Regulator



Model shown is 721AL-125-330-A

## MATERIALS

Body	Anodized Aluminum
Bonnet	Chrome Plated Brass Barstock
Diaphragm	316L Stainless Steel
Seat	PTFE Teflon
Seals	PTFE Teflon
Filter	Sintered Stainless Steel - 10 Micron

The Model HP 721AL is a single stage regulator with anodized aluminum body for primary pressure control of mildly corrosive gases such as ammonia, sulfur dioxide and hydrogen sulfide. This model can also be used in applications requiring a lighter weight regulator. Typical applications include:

- Gas and Liquid Chromatography
- Carrier Gases
- Calibration Gases
- Mildly corrosive gases or mixtures

## FEATURES

- 1-11/16" 316L SS diaphragm eliminates contamination from diffusion or outgassing
- One piece encapsulated seat design includes a 10 micron sintered filter to protect from contamination
- 2" 316 SS gauges (psi/bar)
- Up to 500 psig outlet pressures available
- Designed to 1.0 x 10<sup>-9</sup> cc/sec He leak rate
- Front and rear panel mountable
- 316 SS gauges and fittings

## RELATED OPTIONS

Captured Vent Kit P/N: 9100875  
 Front Panel Mount Kit P/N: 9100871  
 Wall mounting bracket P/N: 9101242



## HP 721AL ORDERING INFORMATION

HP 721AL	-	XXX	-	XXX	-	XX	-	XXXX
MODEL NO.	DELIVERY PRESSURE DELIVERY	(OUTLET GAUGE)	CGA / INLET FITTING	ACCESSORIES	OPTIONS			
HP 721AL	0-15 PSIG	{30" Hg Vac-30 PSIG}	000 (1/4" FNPT)	A) 1/4" FNPT Diaph Valve	1) He Leak Cert (Inboard)			
	0-50 PSIG	{30" Hg Vac-100 PSIG}	001 (1/4" MNPT)	B) 1/4" MNPT Nipple	2) No Gauge			
	0-125 PSIG	{30" Hg Vac-200 PSIG}	240	C) 1/4" FNPT Port	3) w/Relief Valve			
	0-250 PSIG	{30" Hg Vac-400 PSIG}	330	D) 1/4" Tube Fitting	4) He leak Cert ( Outboard)			
	0-500 PSIG	{30" Hg Vac-1000 PSIG}	346	E ) 1/8" Tube Fitting	5) 400 psi inlet gauge <b>Gas Service Must be Specified</b>			
			350					
			580					
			590					
			660					
			705					



## FLOW DATA

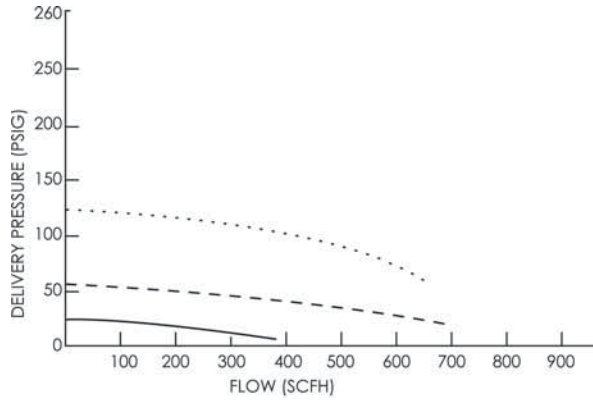

15 @ 200 PSIG INLET ———  
 50 @ 200 PSIG INLET - - - - -  
 125 @ 200 PSIG INLET ······

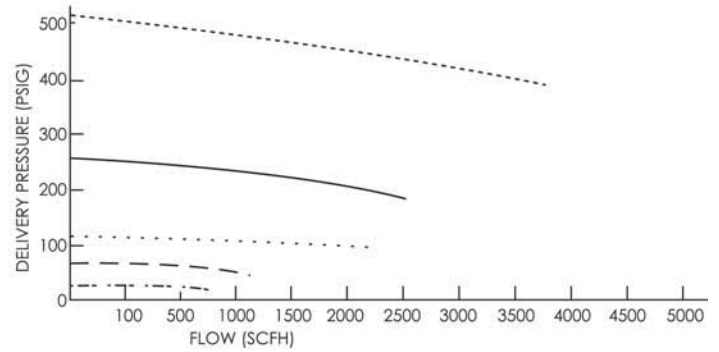

15 @ 2000 PSIG INLET - - - - -  
 50 @ 2000 PSIG INLET - - - - -  
 125 @ 2000 PSIG INLET ······  
 250 @ 2000 PSIG INLET ———  
 500 @ 2000 PSIG INLET ······

## SPECIFICATIONS

- $C_v$ : .08
- Pressure Regulation: 1.8 PSIG/100 PSIG
- Weight: 1.90 Lbs.

## DIMENSIONS

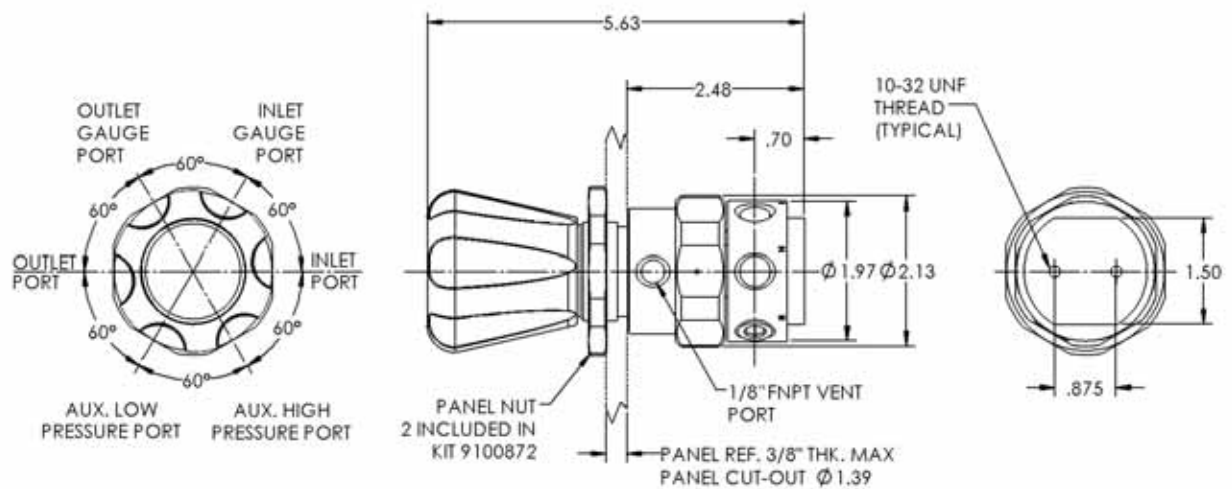

# HP724C

BRASS BACK PRESSURE REGULATOR



The Model HP 724C regulator is intended for upstream or inlet pressure control of high purity applications acting as an adjustable, highly sensitive relief valve:

- Compressors
- Storage vessels
- Gas Chromatography
- Pump pressure control
- Fluid sampling
- Pipeline protection
- Downstream equipment protection ( If properly installed )

## FEATURES

- 15, 50, 125 and 250 PSIG models available
- One piece encapsulated valve design with PTFE seats and 10 micron filter
- Front or rear panel mountable
- Ergonomic knob for improved grip
- 1/4" NPT Ports

## RELATED OPTIONS

Front Panel Mount Kit P/N 9100871  
Wall mounting bracket P/N: 9101242



## MATERIALS

Body	Chrome Plated Brass Barstock
Bonnet	Chrome Plated Brass Barstock
Diaphragm	316L SS
Nozzle	Brass Barstock
Seat	PTFE
Filter	10 micron Nickel Plated Bronze
Adjusting Knob	ABS Plastic

## HP 724C ORDERING INFORMATION

PART NO.	MODEL NO.	RELIEF PRESSURE (PSIG)
4001000	724C-015	1-15 PSIG
4001001	724C-050	5-50 PSIG
4001002	724C-125	10-125 PSIG
4001003	724C-250	20-250 PSIG

## PROCESS EXAMPLE

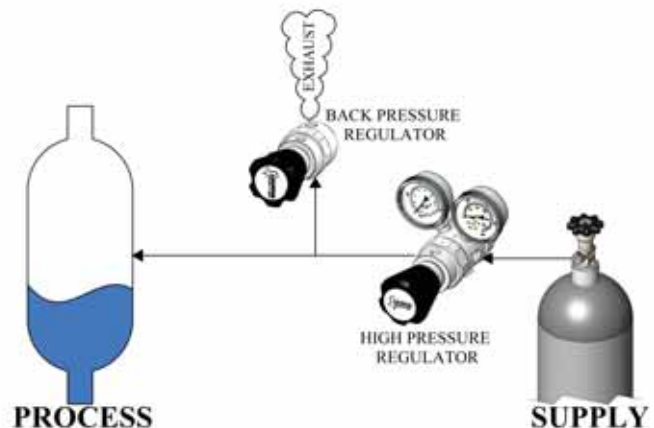





# HP 744

Stainless Steel Back-Pressure Regulator



The Model HP 744 regulator is intended for upstream or inlet pressure control of high purity and corrosive applications acting as a field adjustable, highly sensitive relief valve.

- Research and Development
- Storage vessels
- Gas Chromatography
- Pump pressure control
- Fluid sampling
- Pipeline protection
- Downstream equipment protection ( If properly installed )

## FEATURES

- 15, 50, 125 and 250 PSIG models available
- Open to reseal deviation meets CGA E-14
- One piece encapsulated valve design with PTFE seats and 10 micron filter
- Front or rear panel mountable
- Ergonomic knob for improved grip
- 1/4" NPT Ports

## RELATED OPTIONS

Front Panel Mount Kit – P/N 9100871  
Wall mounting bracket P/N: 9101242



## MATERIALS

Body	316L Stainless Steel Barstock
Bonnet	Chrome Plated Brass Barstock
Diaphragm	316L SS
Nozzle	316L SS
Seat	PTFE
Filter	10 micron Stainless Steel
Adjusting Knob	ABS Plastic

## HP 744 ORDERING INFORMATION

PART NO	MODEL	RELIEF PRESSURE (PSIG)
4001100	744-015	1-15 PSIG
4001101	744-050	5-50 PSIG
4001102	744-125	10-125 PSIG
4001103	744-250	20-250 PSIG

## PROCESS EXAMPLE

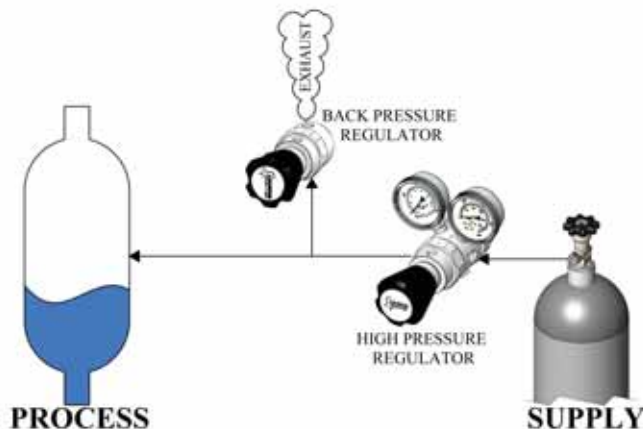

## FLOW DATA

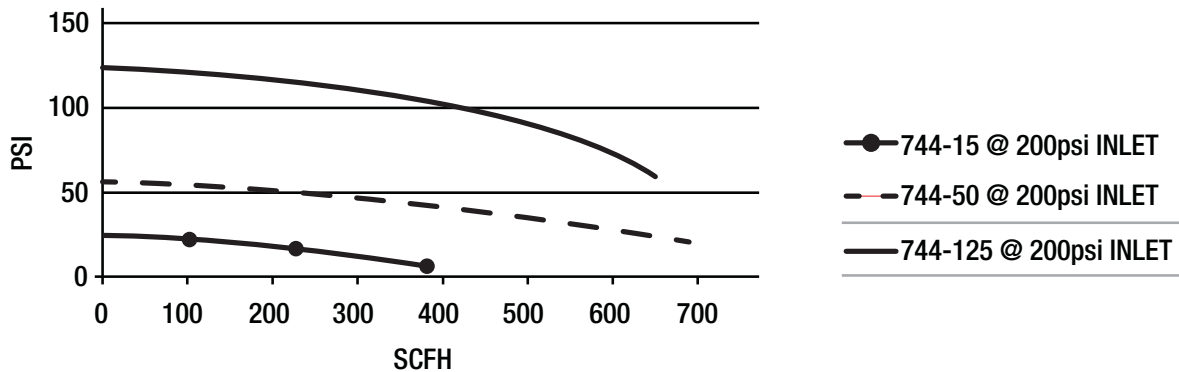

## SPECIFICATIONS

- Cv: .08
- Helium Leak Integrity: 1.0x10<sup>-9</sup> cc/sec
- Weight: 2.3 Lbs.

## DIMENSIONS

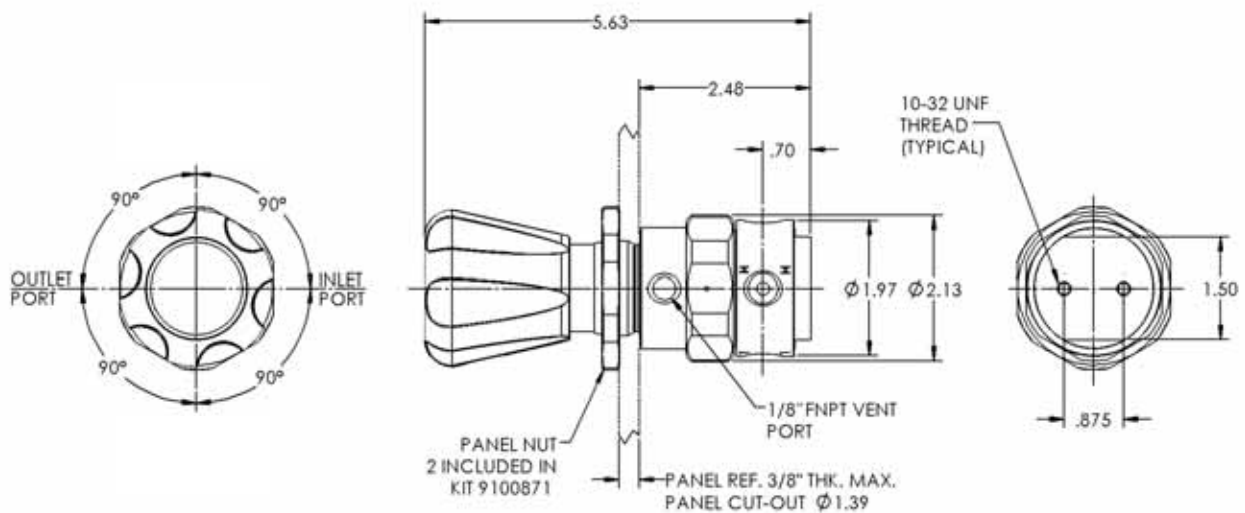

# HP 3520

High Flow - Two Gauge Regulator



Model HP 3520-250 shown

Model HP 3520 is a brass barstock in-line manifold regulator for pipeline and other applications up to 3000 PSIG inlet pressure. The Model HP 3520 is suitable for:

- Non-Corrosive high flow gas applications
- High purity gas applications
- Research sample systems gases
- Process analyzer gases
- Bulk gas distribution systems
- Laser gas systems
- Emission monitoring systems gases

**\*\*Recommended for non-corrosive gases or purity levels Grade 5.0 (99.999) and higher, and delivery pressures up to 500 PSIG**

## FEATURES

- 2 3/4" stainless steel diaphragm eliminates contamination from diffusion or outgassing
- 1/2" FNPT inlet and outlet
- One piece encapsulated seat design includes a sintered filter to protect the seat from particulate contamination
- 2 - 1/2" brass dual scale gauges (psi/bar)
- Maximum inlet 3000 PSIG (500 PSIG for 15 PSIG model)
- Six port configuration, three high pressure and three low pressure

## CYLINDER ADAPTER KITS

CGA 540 Adapter Kit P/N: 9103615

CGA 580 Adapter Kit P/N: 9103616

1/2" NPT male x 1/4" NPT Female bushing P/N: 9005806

## MATERIALS

Body	Brass Barstock
Bonnet	Brass Barstock
Diaphragm†	302 Stainless Steel
Nozzle	Brass
Seat†	PTFE Teflon
Seals	PTFE Teflon
Filter	Nickel Plated Sintered Bronze - 10 Micron
Seat Return Spring	17-7 Stainless Steel
Adjusting Knob	ABS Plastic

## HP 3520 ORDERING INFORMATION

**\* Ships in 24 to 48 hours**

PART NO.	MODEL NO.	DELIVERY PRESSURE		
		DELIVERY	(OUTLET GAUGE)	INLET /OUTLET FITTING
3003560†	HP 3520	0-15 PSIG	(30 psi/2 bar) MAX INLET 500 PSIG	000 (1/2" FNPT)
<b>3003561*</b>		<b>0-50 PSIG</b>	<b>(100 psi/7 bar)</b>	
<b>3003562*</b>		<b>0-125 PSIG</b>	<b>(200 psi/14 bar)</b>	
<b>3003563*</b>		<b>0-250 PSIG</b>	<b>(400 psi/28 bar)</b>	
<b>3003564*</b>		<b>0-500 PSIG</b>	<b>(600psi/40 bar)</b>	

† 0-15 PSIG model has neoprene diaphragm and seat

\*\* Does not apply to 15 PSIG model (P/N:3003560)

NOTE: Regulators with delivery pressure above 15 PSIG should not be used with acetylene.



## FLOW DATA

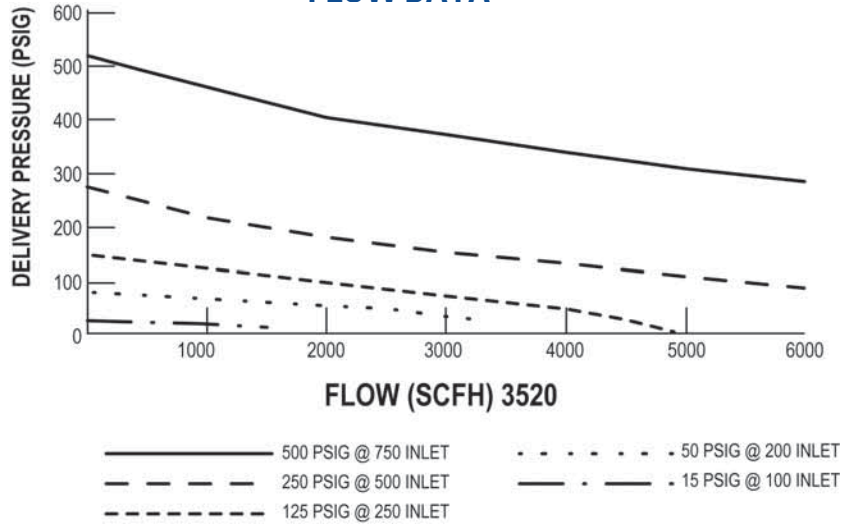

## SPECIFICATIONS

- Pressure Regulation: 1.6 PSIG/100 PSIG
- Weight: 4.5 Lbs.

## DIMENSIONS

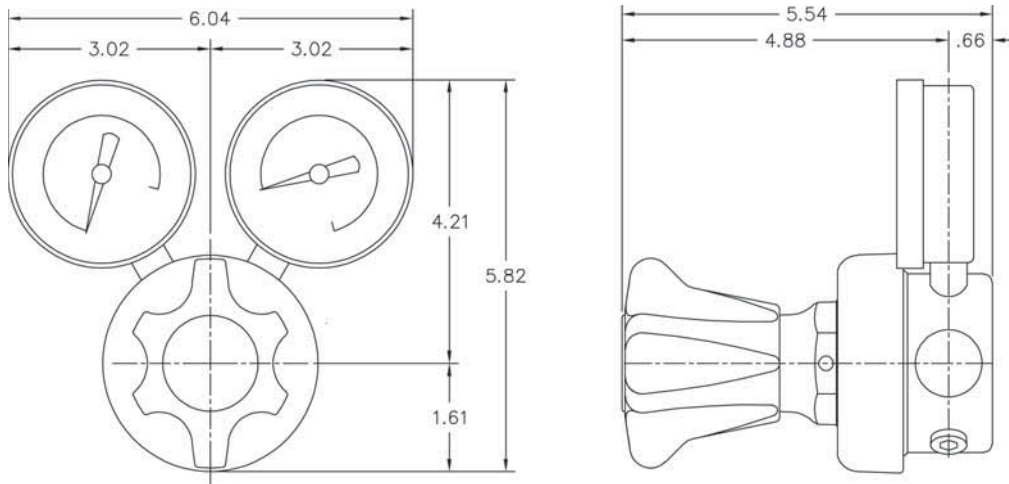

# HP 3530

High Flow - Single Gauge Regulator



Model HP 3530-250 shown

A brass barstock in-line manifold regulator for pipeline and other applications up to 3000 PSIG inlet pressure. The Model HP 3530 is suitable for:

- Non-corrosive high flow gas applications
- High purity gas applications
- Research sample system gases
- Process analyzer gases
- Bulk gas distribution systems
- Laser gas systems
- Emission monitoring systems gases

**\*\*Recommended for non-corrosive gases or purity levels Grade 5.0 (99.999) and higher, and delivery pressures up to 500 PSIG**

## FEATURES

- 2- 3/4" stainless steel diaphragm eliminates contamination from diffusion or outgassing
- 1/2" FNPT inlet and outlet
- One piece encapsulated seat design includes a sintered filter to protect the seat from particulate contamination
- 2 1/2" brass dual scale gauge (psi/bar)
- Maximum inlet 3000 PSIG (500 PSIG for 15 PSIG model)
- Four port configuration, one high pressure and three low pressure

## CYLINDER ADAPTER KITS

- CGA 540 Adapter Kit P/N: 9103615
- CGA 580 Adapter Kit P/N: 9103616
- 1/2" NPT male x 1/4" NPT Female bushing P/N: 9005806

## MATERIALS

Body	Brass Barstock
Bonnet	Brass Barstock
Diaphragm†	302 Stainless Steel
Nozzle	Brass
Seat†	PTFE Teflon
Seals	PTFE Teflon
Filter	Nickel Plated Sintered Bronze - 10 Micron
Seat Return	Spring 17-7 Stainless Steel
Adjusting Knob	ABS Plastic

## HP 3530 ORDERING INFORMATION

**\* SHIPS IN 24 TO 48 HOURS**

PART NO.	MODEL NO.	DELIVERY	DELIVERY PRESSURE (OUTLET GAUGE)	INLET /OUTLET FITTING
4000800†	HP 3530	0-15 PSIG	(30 psi/2 bar) MAX INLET 500 PSIG	000 (1/2" FNPT)
<b>4000801*</b>		<b>0-50 PSIG</b>	<b>0-50 PSIG (100 psi/7 bar)</b>	
<b>4000802*</b>		<b>0-125 PSIG</b>	<b>0-125 PSIG (200 psi/14 bar)</b>	
<b>4000803*</b>		<b>0-250 PSIG</b>	<b>0-250 PSIG (400 psi/28 bar)</b>	
<b>4000804*</b>		<b>0-500 PSIG</b>	<b>0-500 PSIG (1000 psi/70 bar)</b>	

† 0-15 PSIG model has neoprene diaphragm and seat

\*\* Does not apply to 15 PSIG model (P/N: 4000800)

NOTE: Regulators with delivery pressure above 15 PSIG should not be used with acetylene.





## FLOW DATA

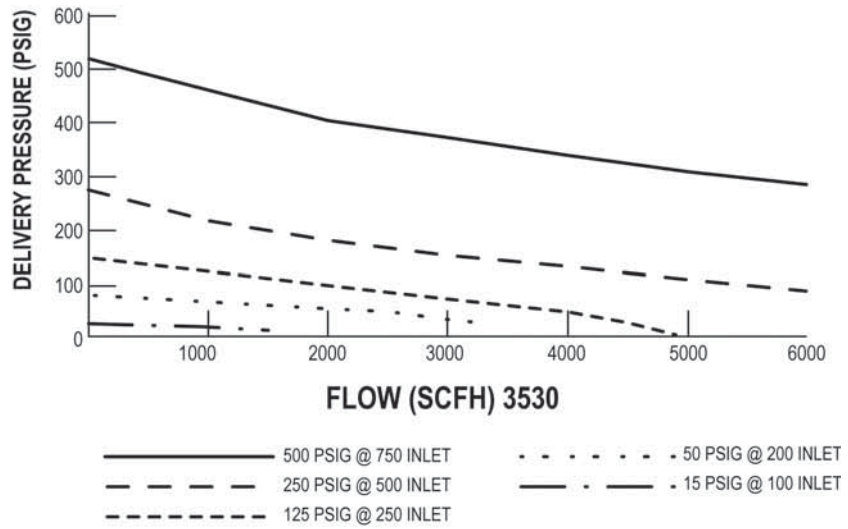

## SPECIFICATIONS

- Pressure Regulation: 1.6 PSIG/100 PSIG
- Weight: 4.3 Lbs.

## DIMENSIONS

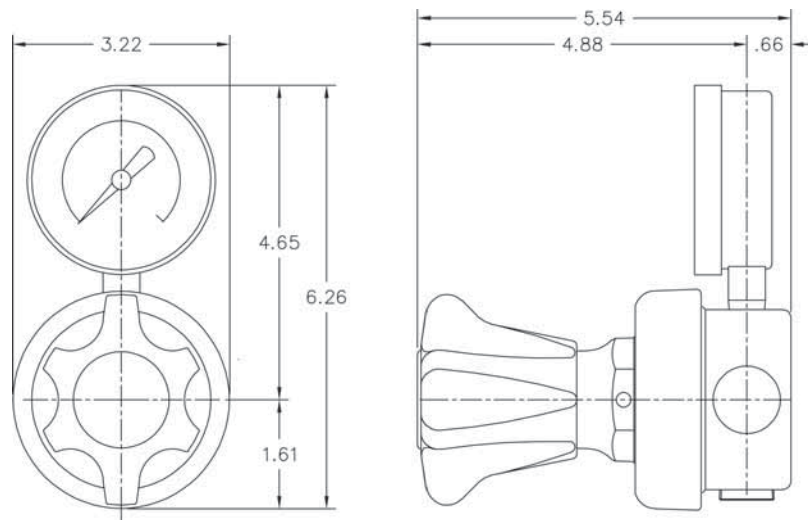

# HP750

Ultra High Flow Servo Dome Regulator



Model HP 750-500-3000 shown

The Model HP 750 series regulator is a high pressure, high flow regulator system. The key to the performance of this regulator is the servo-dome load technology. The servo-dome load feature allows the regulator to supply high flow rates with straight line pressure regulation. The HP 750 is suitable for:

- Laser assist gases
- Pressure transfer
- Blanketing & high flow manifold

## FEATURES

- 0-250, 500, or 1000 PSIG delivery pressure
- 3000 and 5500 PSIG inlet pressures
- Tamper proof, self-reseating internal safety valve on 250 & 500 models only
- One piece encapsulated seat design with 10-micron filtration
- Conforms to CGA E-4 standard for gas pressure regulators

## MATERIALS

Body	Brass Barstock
Bonnet	Brass Barstock
Diaphragm	Teflon Coated Nylon Reinforced Neoprene
Nozzle	Brass
Seat	PTFE Teflon
Seal	PTFE Teflon
Filter	Nickel Plated Sintered Bronze - 10 Micron
Adjusting Knob	Noryl Plastic
Inlet	1/2" FNPT

## RELATED OPTIONS

Panel Mount Kit P/N: 9100887  
 Adaptor 1/2" MNPT x 1/4" FNPT 9005806

## CYLINDER ADAPTER KITS

CGA 540 Adapter Kit P/N: 9103615  
 CGA 580 Adapter Kit P/N: 9103616  
 CGA 680 Adapter Kit P/N: 9103617 (5500 PSIG inlet models only)

## HP 750 ORDERING INFORMATION

**\* SHIPS IN 24 TO 48 HOURS**

PART NO.	MAX. INLET MODEL NO.	DELIVERY PRESSURE RANGE PSIG	DELIVERY PRESSURE GAUGE PSI	SUPPLY PRESSURE PRESSURE GAUGE PSIG	PSIG
3000860*	HP750-500-3000	3000	0-500	600	4000
3000865*	HP750-250-3000	3000	0-250	400	4000
3000866*	HP750-1000-3000	3000	0-1000	2000	4000
3000867	HP750-250-5500	5500	0-250	400	6000
3000868	HP750-500-5500	5500	0-500	600	6000
3000869*	HP750-1000-5500	5500	0-1000	2000	6000
3000951*	HP750-250-540	3000	0-250	400	4000
3000952*	HP750-500-580	3000	0-500	600	4000
3003028	HP750-500-680	5500	0-500	600	6000



## FLOW DATA

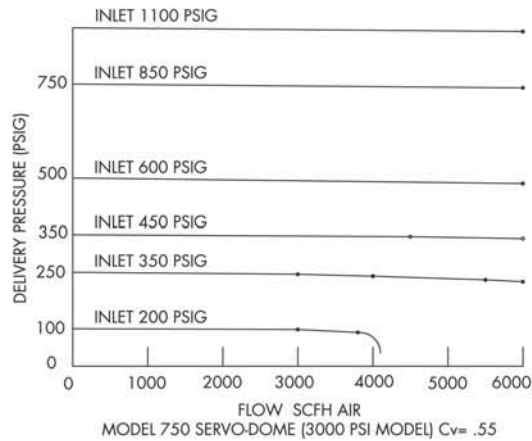

## SPECIFICATIONS

- Cv: .55 on 3000 psi inlet models
- Cv: .4 on 5500 psi inlet models
- Pressure Regulation: 3 PSIG/1000 PSIG for 250 and 500 psi delivery pressure  
5 PSIG/1000 PSIG for 1000 psi delivery pressure
- Weight: 8.5 lbs.

## DIMENSIONS

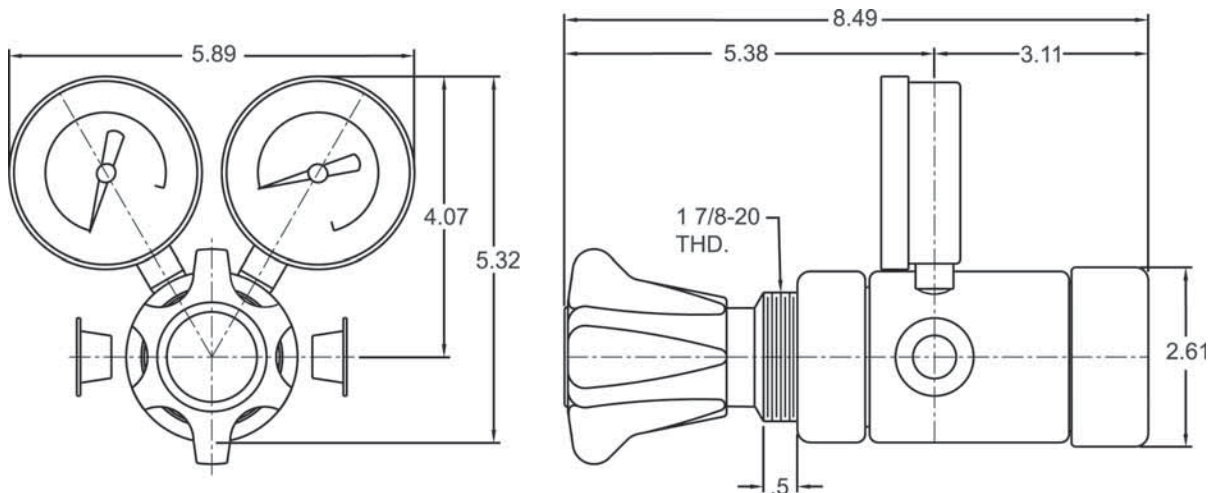

# HP 752

High Flow Remote Servo Dome Regulator System



Model HP 752  
P/N: 3000871 - Servo-Dome Regulator

## MATERIALS

Body	Brass Barstock
Bonnet	Brass Barstock
Diaphragm	Teflon Coated Nylon Reinforced Neoprene
Nozzle	Brass
Seat	PTFE Teflon
Seal	Viton, PTFE
Filter	Nickel Plated Sintered Bronze - 10 Micron
Seat Return Spring	Stainless Steel

**SHIPS  
24  
TO  
48hr**

The Model HP 752 series regulator is a remote high pressure, high flow regulator system. The key to the performance of this regulator is the servo-dome load technology. The servo-dome load feature allows the regulator system to supply and control high flow rates with straight line pressure regulation. The HP 752 is suitable for:

- Laser assist gases
- Pressure transfer
- Blanketing & high flow manifold delivery systems

Note: HP 752 requires pilot regulator (included) for proper function (see below).

## FEATURES

- 0- 500 PSIG delivery pressure
- Up to 3000 PSIG inlet pressure
- One piece encapsulated seat design with 10-micron filtration
- 1/2" diameter sensing line for precise servo flow control
- 1/4" diameter dome pressure line
- Front panel mount bonnet on remote pilot regulator
- Model 752 inlet & outlet: 1/2" FNPT
- Remote pilot regulator can be mounted up to 100 feet away

## RELATED OPTIONS

Front Panel Mount Kit P/N: 9100887

## CYLINDER ADAPTER KITS

CGA 540 Adapter Kit P/N: 9103615

CGA 580 Adapter Kit P/N: 9103616

## HP 752 ORDERING INFORMATION

PART NO.	MODEL	DESCRIPTION
3000885	Model 752	Servo Dome Regulator w/ Remote Pilot Regulator



Pilot Regulator P/N: 3000872



## FLOW DATA

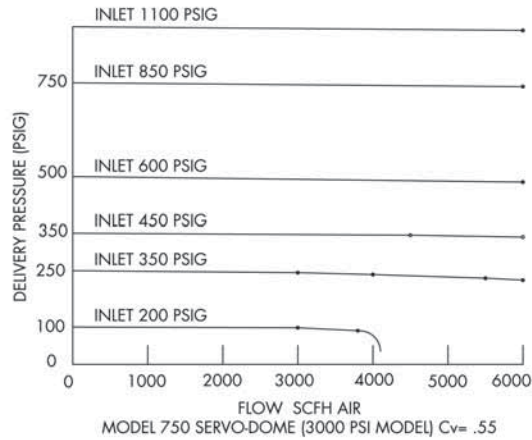

## SPECIFICATIONS

- Cv: .55
- Pressure Regulation: 3 PSIG/1000 PSIG
- Weight: 4.48 Lbs. - Servo Dome Regulator  
5.8 Lbs. - Remote Pilot Regulator

## DIMENSIONS

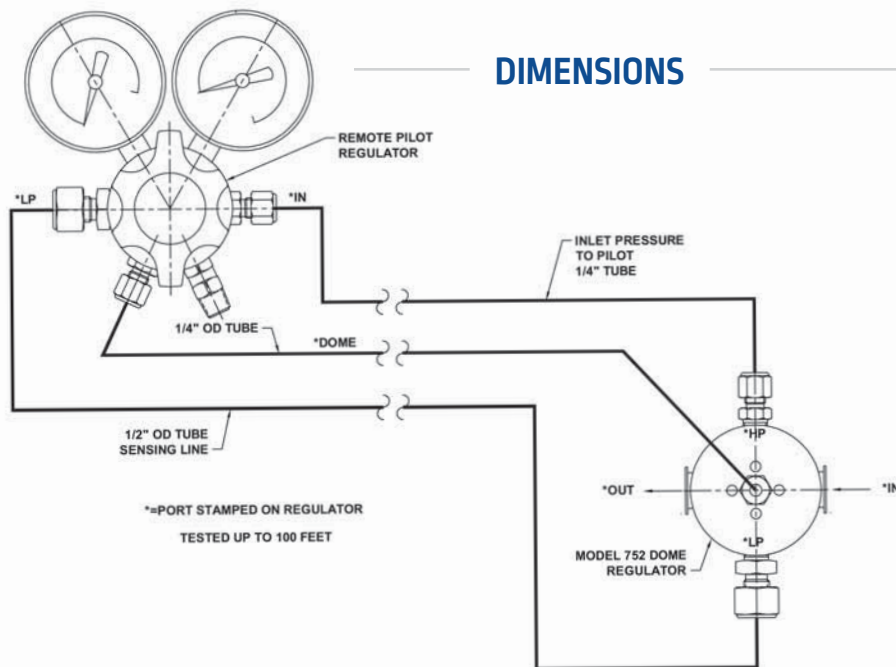

# 9200NC

Low Delivery Regulator



The Model 9200NC low delivery regulator maintains an accurate delivery pressure over the life of the cylinder. The two-stage design limits the variations in the outlet pressure to 0.03 psig for every 100 psig of inlet pressure decay. Made of durable, long-lasting brass, this regulator is perfect for non-corrosive, ultra-low delivery pressure gases. A needle valve is included on the outlet.

This two-stage regulator is recommended for use with non-corrosive gases in applications where an ultra-low delivery pressure is required.

## FEATURES

- Large Surface Area Elastomeric diaphragm: provides a precise pressure control from full cylinder to empty
- One piece encapsulated seat design includes a 10 micron sintered filter to protect the seat from particles and extend the service life
- Unique delivery gauge to provide a 0.1 psi graduation
- Inter-stage relief valve protects the second stage of the regulator from over-pressurization

## SPECIFICATIONS

Maximum Rated Inlet Pressure: 3000 psig  
 Outlet Pressure Ranges: 0.25 - 2 PSIG  
 0.25 - 6 PSIG  
 Ambient Operating Temperature: -20<sup>o</sup> F to +140<sup>o</sup> F  
 Designed Leak Rate: Bubble-Tight (Helium)  
 Ports (5): 1/4" FNPT  
 Outlet: 1/4" NPT male

## MATERIALS

Body	Brass
Bonnet	Brass
Diaphragm	1st Stage Neoprene 2nd Stage Neoprene
Gauges	2 1/2" Brass
Filter	Sintered Bronze
Valve Stem	302 Stainless Steel
Valve Spring	18-8 Stainless Steel
1st Stage Seat	PTFE
2nd Stage Seat	Neoprene

## 9200NC ORDERING INFORMATION

PART NO.	GAS	MODEL NO.	DELIVERY PRESSURE (PSIG)	CGA FITTING
3302313	Carbon Dioxide	9200NC-2-320	0-2	320
3302293	Flammable	9200NC-2-350	0-2	350
3302292	Inert	9200NC-2-580	0-2	580
3302314	Ind Air	9200NC-2-590	0-2	590
3302315	Carbon Dioxide	9200NC-6-320	0-6	320
3302316	Flammable	9200NC-6-350	0-6	350
3302317	Inert	9200NC-6-580	0-6	580
3302318	Ind Air	9200NC-6-590	0-6	590





## SPECIFICATIONS

- Cv: 0.06
- Pressure Regulation: 0.03/100PSIG
- Weight: 5 lbs.

## DIMENSIONS

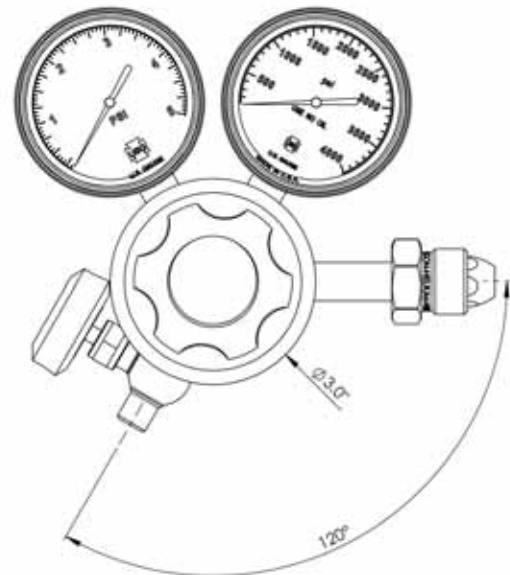
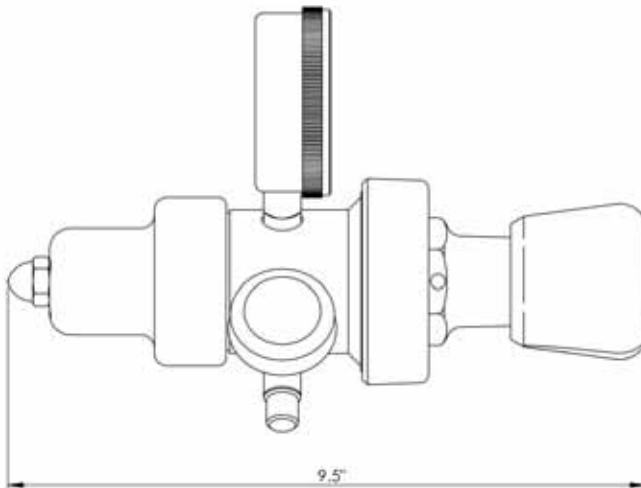

# MR5 & MR6

Compact Single Stage Regulators



Model MR5 Shown

These single stage diaphragm regulators have a compact design and a small internal volume of 2.6 cubic centimeters, which makes them ideal for use in portable calibration and analyzer applications. The low internal volume provides an ease of purging with minimal gas usage and reduces the potential of contaminants entering into the gas stream.

The MR5 is suitable for non-corrosive gas service, while the MR6 is can be used with mildly corrosive gases. Typical applications for these regulators are lecture bottle use, EPA protocol standards, low level VOC gases and high purity gases.

## FEATURES

- Low internal volume of 2.6 cc allows for rapid purging in analytical instrumentation applications
- Lightweight and compact design allows for ease of transportation with small cylinders
- Stainless steel diaphragm minimizes diffusion of air into the regulator and eliminates "off gassing" associated with elastomeric diaphragms

## SPECIFICATIONS

Maximum Rated Inlet Pressure: 3000 psig  
 Outlet Pressure Ranges: 0-30 and 0-100 PSIG  
 Ambient Operating Temperature: -40<sup>o</sup> F to +140<sup>o</sup> F  
 Designed Leak Rate: Bubble-Tight (Helium)  
 Body A: Inlet/outlet 1/4" FNPT; Gauge 1/8" FNPT  
 Body B + C: 1/8" FNPT

## MATERIALS

MR5 Body	Brass
MR6 Body	Stainless Steel
Bonnet	Black Anodized Aluminum
Diaphragm	316 Stainless Steel
Gauges	1.5"
MR5	Brass
MR6	Stainless Steel
Seat	Teflon
Seals	Teflon

## MR5 & MR6 ORDERING INFORMATION

MODEL NO.	BODY STYLE	DELIVERY PRESSURE DELIVERY	(OUTLET GAUGE)	CGA INLET FITTING	ACCESSORIES	OPTIONS
MR5 (Brass Body)		0-30 PSIG 0-100 PSIG	0-60 PSIG 0-150 PSIG 320	000 (1/8" or 1/4" FNPT) See Body Style 001 (1/8" or 1/4" FNPT) See Body Style	A) 1/4" Needle Valve B) 1/4" Diaphragm Valve C) Male NPT (1/8" or 1/4") D) Female NPT (1/8" or 1/4")	1) He Leak Cert. (Inboard) 2) He Leak Cert. (Outboard) 3) No Gauges
MR6 (316l SS Body)				002 1/4" Tube Fitting 003 1/8" Tube Fitting 004 1/4" Brass 005 1/8" Brass	E) 1/4" Tube Fitting F) 1/8" Tube Fitting G) 1/4" Hose Barb H) 1/8" Hose Barb	
				170 180 320 330 590	346 350 540 580 590	



### MR5

- Cv: 0.08
- Pressure Regulation: 2.0 PSI per 100 PSI
- Weight: 1.0 lbs..

### MR6

- Cv: 0.08
- Pressure Regulation: 2.0 PSI per 100 PSI
- Weight: 1.0 lbs.

### BODY A

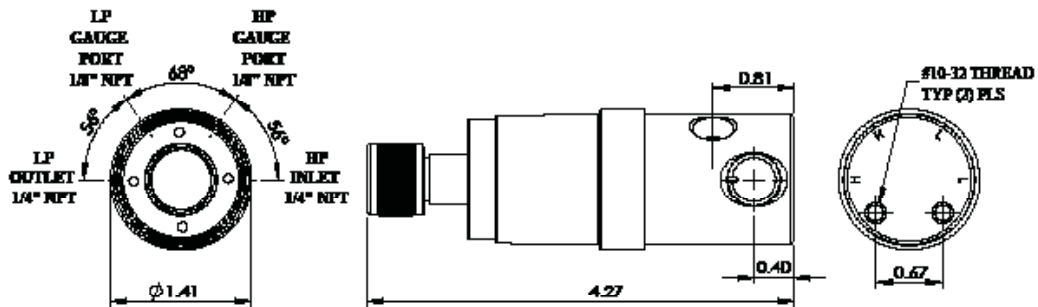

### BODY B

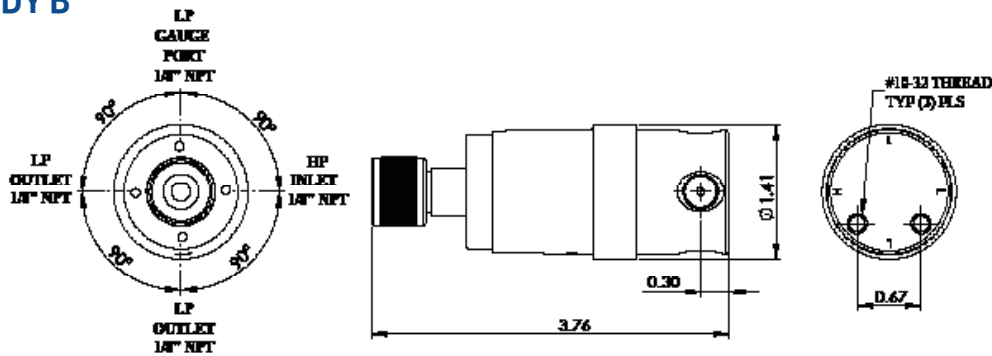

### BODY C

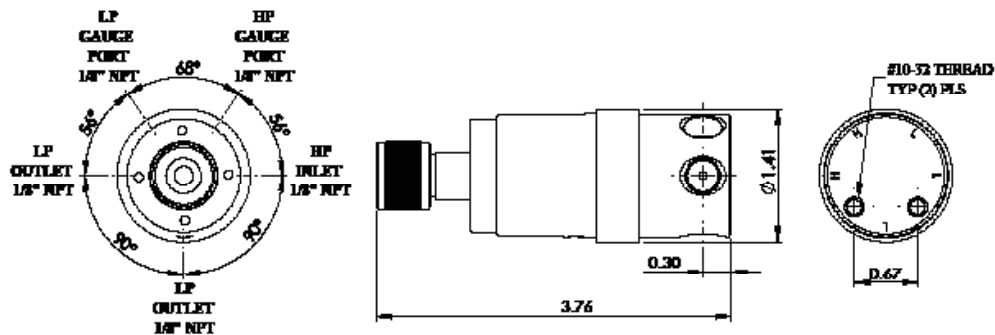

# 240 LIQUID CYLINDER SWITCHOVER



## SERIES 240

The Series 240 Manifold is designed specifically to regulate and monitor vaporized gas from cryogenic cylinders. The Series 240 Manifold prevents downtime by automatically switching over when the primary cylinder bank is depleted. A green light indicates the primary cylinder service bank is functioning and the reserve cylinder bank is ready for service. A red light signals that the system has changed over and one or both banks are depleted. The user resets the primary bank by turning the knob.

## FEATURES

- Adaptable up to 3 cylinders per side
- Electrical - 115 volts (AC)
- Maximum inlet pressure 230 or 350 PSIG
- Manifold outlet - 1/2" NPT
- Relief valve outlet - 1/4" NPT
- 240 Series for use with 235 PSIG relief valve liquid cylinders
- 240HP Series for use with 350 PSIG relief valve liquid cylinders
- Remote alarm available
- Economizer Circuit

## ORDERING INFORMATION

SERIES	RIGHT [# CYLINDERS]	LEFT [# CYLINDERS]	GAS SERVICE
	<b>72" Pigtails</b>	<b>72" Pigtails</b>	
240	1R72	1L72	320-Carbon Dioxide
240HP	2R72	2L72	540-Oxygen
	3R72	3L72	580-Argon/Nitrogen 326-Nitrous Oxide

## OPTIONAL ACCESSORIES

- 4300698 - Remote Alarm Box
- 4300699 - 10ft. Alarm Cable
- 4300709 - 50ft. Alarm Cable
- 9101996 - CGA 320 Pigtail, 72"
- 9101997 - CGA 540 Pigtail, 72"
- 9101998 - CGA 580 Pigtail, 72"

Custom Configurations Available Upon Request  
Contact Customer Service. - 1.800.733.4043

# 240 LIQUID CYLINDER SWITCHOVER



Typical Layout

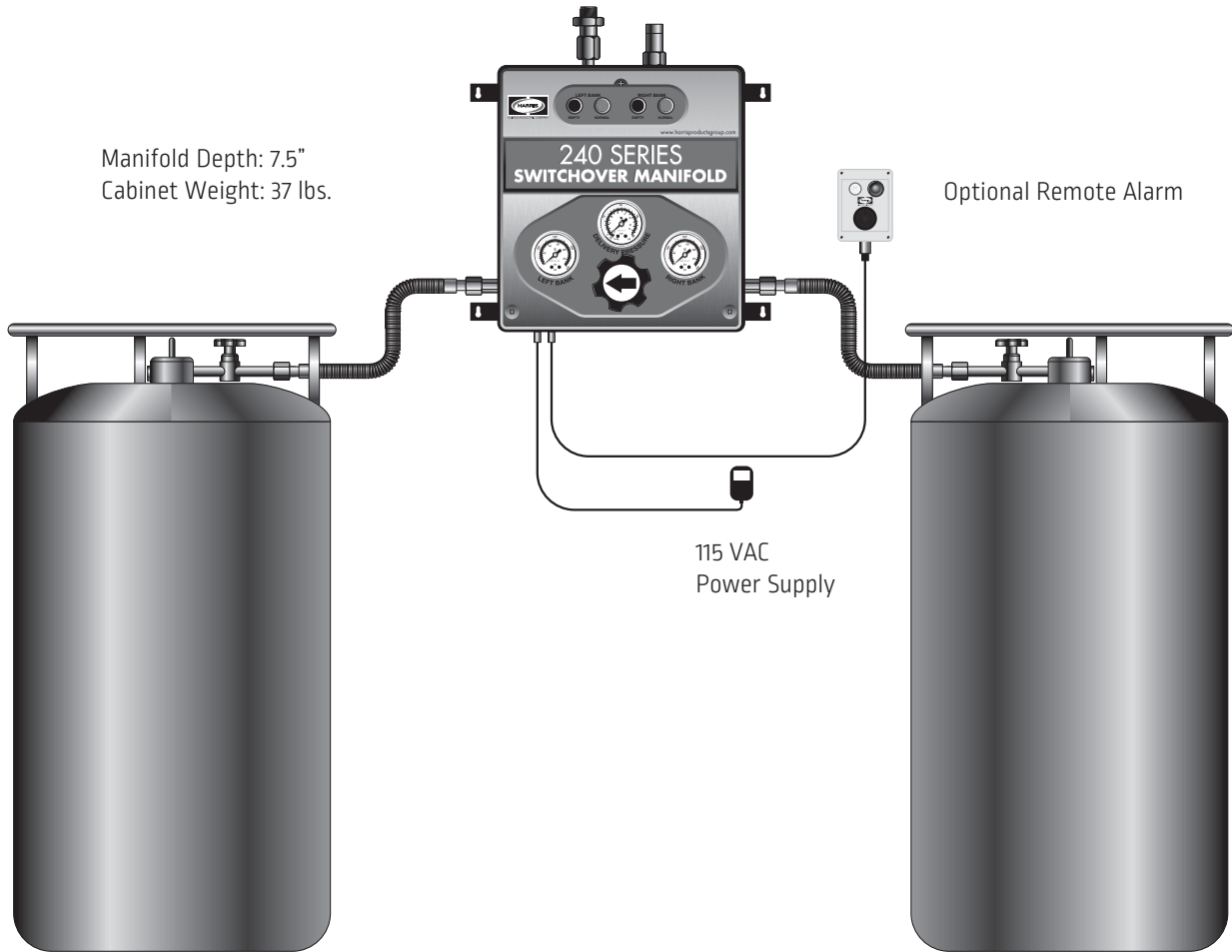

## SPECIFICATIONS

SERIES	MAXIMUM INLET PRESSURE	MAXIMUM FLOW RATE	INTERNAL ADJUSTABLE LINE REGULATOR DELIVERY RANGE
240	235 PSIG	750 SCFH	40-85 PSIG
240HP	350 PSIG	800 SCFH	40-180 PSIG

Custom Configurations Available Upon Request  
 Contact Customer Service. - 1.800.733.4043



# 910EZ

## REGULATOR MOUNTING STATION



Model 721C - 050 - 580 - BER shown

The EZ Mount accessory enables a practical and safe wall-mounted installation of any Harris high-purity bar stock cylinder regulator. This simple design allows for right out-of-the-box installation of the regulator assembly onto a wall or structure. The convenient, compact design significantly minimizes the amount of valuable wall space normally required to wall mount regulators.

The EZ Mount accessory is available with a choice of 1 or 2 all stainless steel flexible pigtails in 36", 48" or 72" lengths and a wall-mount bracket. It is equipped with a CGA connection with integrated check valves to prevent contaminants from entering the gas delivery supply during cylinder change out. The mounting brackets are fabricated from 16 gauge aluminum for durable, long-life service and are suitable for most environments and locations.

- Compact design minimizes valuable wall space required to wall mount regulators
- Convenient installation - ready to mount right out-of-the-box
- Regulator available with a packless diaphragm valve for easy shut-off
- Safe & efficient - eliminates the need to handle regulator during cylinder change-outs
- Regulator available with a wide range of outlet compression fittings
- Check valve CGA prevents contaminants from entering gas stream
- Maximum inlet pressure 3000 psig
- Cleaned to CGA G-4.1

## 910EZ ORDERING INFORMATION

PART NO.	MATERIAL	REGULATORS	NUMBER OF CYLINDERS
Call customer service at 1.800.733.4043	Brass	721, 721C, 722, 722C	1
Option 2 for part numbers for your specific application	Brass	721, 721C, 722, 722C	2
	Stainless Steel	741 & 742	1
	Stainless Steel	741 & 742	2

## SPECIFICATIONS

Maximum Rated Inlet Pressure: 3000 psig

Temperature Range: -40°F to +165°F

Weight: 2 lbs (without regulator)

Bracket: 16 Gauge Aluminum

Pigtail - One or Two

Available lengths are 36", 48" and 72" 316 stainless steel flexible hose (other lengths are available by special order)

Choose EZ Mount as an accessory when ordering regulators listed below.

Model 721/ 721C see P. 14

Model 722/ 722C see P. 16

Model 741 see P.8

Model 742 see P.10







Model HP 717 is a uniquely designed regulator for acetylene applications. This regulator prevents overdrawing the acetylene cylinder where acetone or other solvents can be pulled into the gas stream and damage downstream equipment. The regulator shuts off the flow of gas when acetylene cylinder pressures become too low to support the process. Outlet needle valve for flow control comes with all units.

### FEATURES

- 316L stainless steel diaphragm eliminates contamination from diffusion or outgassing
- One piece encapsulated seat design includes a 10 micron sintered filter to protect the seat from particulate contamination
- 2" dual scale chrome plated brass gauges
- Outlet gauge is red zoned from 15 to 30 psi
- Front and rear panel mountable
- Shuts off gas flow from the cylinder at 85 psi to prevent solvents from contaminating the gas stream



### RELATED OPTIONS

Front Panel Mount Kit P/N: 9100871

### MATERIALS

Body/Bonnet	Brass Barstock
Diaphragm	316L Stainless Steel
Nozzle	Brass
Seat	PTFE Teflon®
Seals	PTFE Teflon®
Filter	Nickel-Plated Sintered Bronze - 10 Micron
Seat Return Spring	PH17 7 Stainless Steel
Adjusting Knob	ABS Plastic

PART NO.	DELIVERY PRESSURE	CGA INLET FITTING	OUTLET FITTING
3300017	15 PSI	510A	Needle valve with 1/4" FNPT



# SG 910 SS

PROTOCOL MOUNTING STATION



The SG 910 stainless steel single regulator protocol station can be ordered for one or two cylinders. A variety of outlet regulators are available based on delivery pressure and material requirements.

Protocol stations can be ordered with outlet regulator or separately. See regulator ordering information.

## FEATURES

- Wall bracket included
- Maximum inlet pressure 3000 PSIG
- Includes 36" all stainless steel pigtail with stainless steel CGA and integral check valve
- Select regulator on page 63



Shown with Model 741 Regulator Attached



## SG 910SS ORDERING INFORMATION

**\* SHIPS IN 24 TO 48 HOURS**

PART NO.	MODEL NO.	GAS SERVICE	BRACKET ONLY (NO PIGTAIL)
<b>1 CYLINDER</b>			
4704520*	910SS-1-296	CGA 296-Oxidizing Mixtures	4702845
4700480*	910SS-1-320	CGA 320-Carbon Dioxide	4702819
4700494*	910SS-1-330	CGA 330 Corrosive	4702820
4700481*	910SS-1-346	CGA 346- Air (Breathing)	4702821
4700482*	910SS-1-350	CGA 350-Hydrogen	4702822
4700483*	910SS-1-510	CGA 510-Acetylene	4702823
4700484*	910SS-1-540	CGA 540-Oxygen	4702824
4700485*	910SS-1-580	CGA 580-N <sup>2</sup> /He/Ar	4702825
4700486*	910SS-1-590	CGA 590-Air(Industrial)	4702826
4700495*	910SS-1-660	CGA 660 Corrosive	4702827
<b>2 CYLINDERS</b>			
4700487	910SS-2-320	CGA 320-Carbon Dioxide	4702835
4700496	910SS-2-330	CGA 330 Corrosive	4702836
4700488	910SS-2-346	CGA 346-Air (Breathing)	4702837
4700489	910SS-2-350	CGA 350-Hydrogen	4702838
4700490	910SS-2-510	CGA 510-Acetylene	4702839
4700491	910SS-2-540	CGA 540-Oxygen	4702840
4700492	910SS-2-580	CGA 580-N <sup>2</sup> /He/Ar	4702841
4700493	910SS-2-590	CGA 590-Air (Industrial)	4702842
4700497	910SS-2-660	CGA 660 Corrosive	4702843



# PROTOCOL STATION OUTLET REGULATORS



SG910 SS PROTOCOL MOUNTING STATION

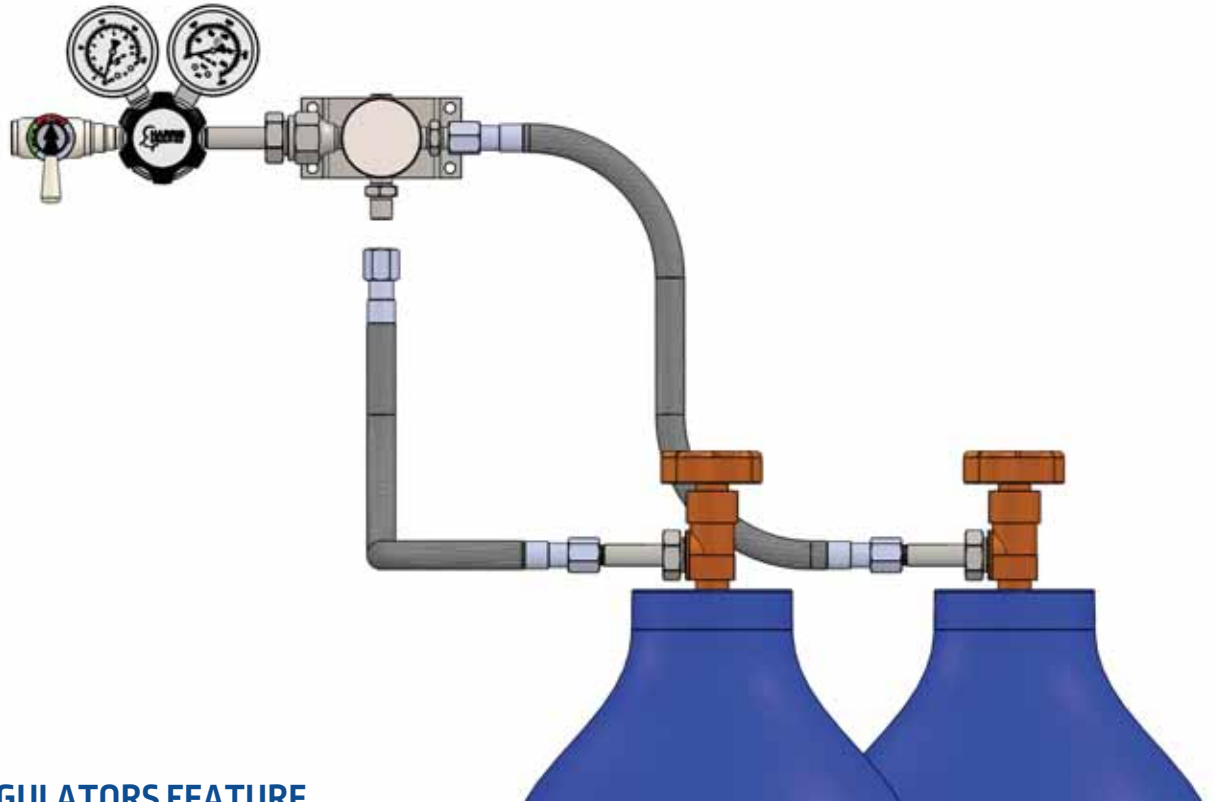

## OUTLET REGULATORS FEATURE

- Stainless steel barstock bodies
- One-piece encapsulated seat
- Stainless steel diaphragm
- $C_v$  = Single stage .08 - Two stage .06
- See Technical Data on pages 8 and 10

## MODEL 741 SINGLE STAGE REGULATOR W/ DIAPHRAGM VALVE AND PROTOCOL STATION

DELIVERY PSIG	PART NUMBER
0-15	741-015-CGA-A-G
0-50	741-050-CGA-A-G
0-125	741-125-CGA-A-G
0-250	741-250-CGA-A-G
0-500	741-500-CGA-A-G



Model 741 Regulator

## MODEL 742 TWO STAGE REGULATOR W/ DIAPHRAGM VALVE AND PROTOCOL STATION

DELIVERY PSIG	PART NUMBER
0-15	742-015-CGA-A-G
0-50	742-050-CGA-A-G
0-125	742-125-CGA-A-G
0-250	742-250-CGA-A-G
0-500	742-500-CGA-A-G

## RELATED OPTIONS

DESCRIPTION	PART NO.
Purge Assembly - Stainless Steel see page 90	
Regulator Alarm Kit-	
	HP Stainless Steel - 4300487
	LP Stainless Steel - 4300427



THE HARRIS PRODUCTS GROUP  
www.harrisproductsgroup.com

Orders: 1.800.733.4043

# SG 910 BR

PROTOCOL STATION



The SG 910 brass single regulator protocol station can be ordered for one or two cylinders. A variety of outlet regulators are available based on delivery pressure and material requirements.

Single regulator protocol station can be ordered with outlet regulator or separately. See regulator ordering information.

## FEATURES

- Wall bracket included
- Maximum inlet pressure 3000 PSIG
- Includes 36" stainless steel lined stainless steel pigtail with CGA integral check valve
- Select regulator on page 67

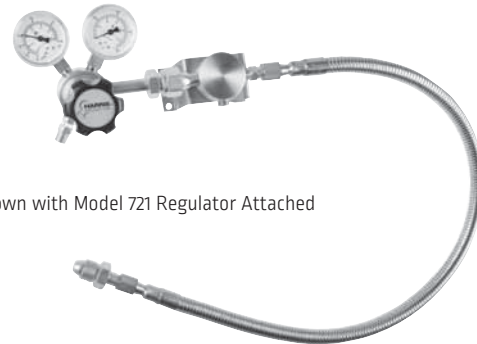

Shown with Model 721 Regulator Attached



## SG 910BR ORDERING INFORMATION

**\* SHIPS IN 24 TO 48 HOURS**

PART NO.	MODEL NO.	GAS SERVICE	BRACKET ONLY (NO PIGTAIL)
<b>1 CYLINDER</b>			
4700465*	910BR-1-320	CGA 320-Carbon Dioxide	4702814
4700466*	910BR-1-346	CGA 346- Air (Breathing)	4702815
4700467*	910BR-1-350	CGA 350-Hydrogen	4702816
4700468*	910BR-1-510	CGA 510-Acetylene	4702817
4700469*	910BR-1-540	CGA 540-Oxygen	4702813
4700470*	910BR-1-580	CGA 580-N <sup>2</sup> /He/Ar	4702812
4700471*	910BR-1-590	CGA 590-Air(Industrial)	4702818
<b>2 CYLINDERS</b>			
4700472	910BR-2-320	CGA 320-Carbon Dioxide	4702830
4700473	910BR-2-346	CGA 346-Air(Breathing)	4702831
4700474	910BR-2-350	CGA 350-Hydrogen	4702832
4700475	910BR-2-510	CGA 510-Acetylene	4702833
4700476	910BR-2-540	CGA 540-Oxygen	4702829
4700477	910BR-2-580	CGA 580-N <sup>2</sup> /He/Ar	4702828
4700478	910BR-2-590	CGA 590-Air(Industrial)	4702834



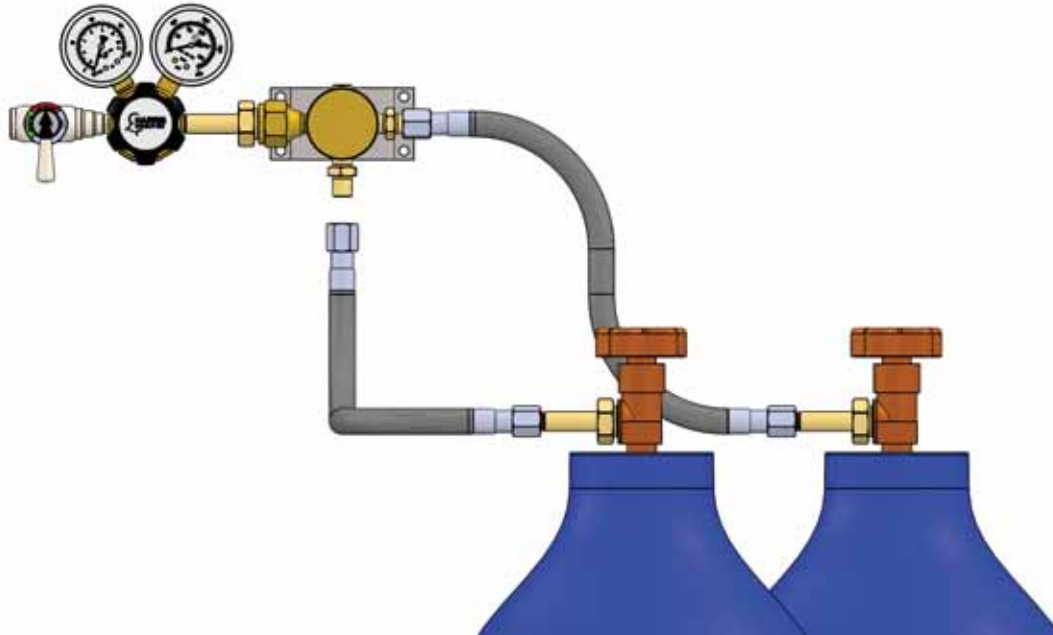

## OUTLET REGULATORS FEATURE

- Brass barstock bodies
- One-piece encapsulated seat
- Stainless steel diaphragm
- External relief valve
- $C_v$  = Single stage .08 - Two stage .06
- See Technical Data on pages 14 and 16

## MODEL 721 SINGLE STAGE REGULATOR W/ DIAPHRAGM VALVE AND PROTOCOL STATION

DELIVERY PSIG	PART NUMBER
0-15	721-015-CGA-B-H
0-50	721-050-CGA-B-H
0-125	721-125-CGA-B-H
0-250	721-250-CGA-B-H
0-500	721-500-CGA-B-H



Model 721 Regulator

## MODEL 722 TWO STAGE REGULATOR W/ DIAPHRAGM VALVE AND PROTOCOL STATION

DELIVERY PSIG	PART NUMBER
0-15	722-015-CGA-B-H
0-50	722-050-CGA-B-H
0-125	722-125-CGA-B-H
0-250	722-250-CGA-B-H
0-500	722-500-CGA-B-H

## RELATED OPTIONS

DESCRIPTION	PART NO.
Purge Assembly - Brass see page 90	
Regulator Alarm Kit-	
HP Chrome Plated Brass	4300485
LP Chrome Plated Brass	4300425

# SG 920

## AUTOMATIC SWITCHOVER SYSTEM



The SG 920 BR / SG 920 SS semi-automatic high purity switchover prevents downtime by automatically switching gas supply from the primary cylinder bank to the reserve cylinder bank. The user resets the primary bank by turning the knob. Manual adjustment of the individual regulators is not required. All systems include a line control regulator.

### FEATURES

- Maximum inlet pressure 3000 PSIG
- Delivery pressure: 0-100, 0-200 PSIG
- Inlet/outlet - 1/4" NPT
- Headers include diaphragm-type shut-off valves
- All systems include stainless steel pigtailed with check valves and stainless steel inner core
- Includes inlet and outlet isolation valves
- All pigtailed have protective armor casing for added safety

### RELATED OPTIONS

- 4302673 - G 277 Two Cylinder Process Station
- 4302675 - G 400P Four Cylinder Process Station
- 4302676 - G 600P Six Cylinder Process Station
- 300329 - Remote alarm box

### OPERATING SPECIFICATIONS

MODEL	MAXIMUM INLET PRESSURE	MAXIMUM FLOW RATE	DELIVERY RANGE
920	3000 PSIG	200 SCFH	100 PSIG
920 HP	3000 PSIG	200 SCFH	200 PSIG

## SG 920 ORDERING INFORMATION

SG 920 BR / SG 920 SS	XX(XX)	XX(XX)	XXX
	RIGHT HEADER (# CYLINDERS)	LEFT HEADER (# CYLINDERS)	GAS SERVICE
920 BR (100PSI)	24" Pigtailed 1R	24" Pigtailed 1L	320 - Carbon Dioxide
920 BR HP (200PSI)	2R	2L	346 - Air (Breathing)
920 SS (100PSI)	3R	3L	350 - Hydrogen
920 SS HP (200PSI)	4R	4L	500 - Medical Mixtures
			540 - Oxygen
			580 - N <sub>2</sub> /He/Ar
CUSTOM CONFIGURATIONS AVAILABLE UPON REQUEST. CONTACT CUSTOMER SERVICE.	36" Pigtailed 1R36	36" Pigtailed 1L36	590 - Air (Industrial)
	2R36	2L36	660 - Corrosive Gases (920 SS only)
	3R36	3L36	330 - Corrosive Gases (920 SS only)
	4R36	4L36	







# SG 905

## SWITCHOVER MANIFOLDS BRASS & STAINLESS STEEL



The SG 905 BR / SG 905 SS semi-automatic high purity switchover prevents downtime by automatically switching gas supply from the primary cylinder bank to the reserve cylinder bank. The user resets the primary bank by turning the knob. Manual adjustment of the individual regulators is not required. All systems include a line control regulator.

### FEATURES

- Wall mounting panel and brackets included
- Maximum inlet pressure 3000 PSIG
- Delivery pressure: 0-15, 0-50, 0-125, 0-250, 0-500 except acetylene (CGA 510A) 0-15 psig
- Inlet/outlet - 1/4" NPT
- Headers include diaphragm-type shut-off valves
- All systems include stainless steel pigtails with check valves and stainless steel inner core and armor casing for added safety.
- Acetylene (CGA 510A) includes dry-type flash arrestors on pigtail end

### RELATED OPTIONS

- 4302473 - Two Cylinder Process Station
- 4302615 - Four Cylinder Process Station
- 4302616 - Six Cylinder Process Station

### SG 905 ORDERING INFORMATION

MATERIAL	MODEL	DELIVERY PRESSURE	RIGHT # CYLINDERS	GAS SOURCE RIGHT	PIGTAIL LENGTH RIGHT	VALVE SPACING	LEFT # CYLINDERS	GAS SOURCE LEFT	PIGTAIL LENGTH LEFT	VALVE SPACING	INLET CGA
	<b>XX</b>	<b>XXX</b>	<b>X</b>	<b>X</b>	<b>XX</b>	<b>(X)</b>	<b>X</b>	<b>X</b>	<b>XX</b>	<b>(X)</b>	<b>XXX</b>
BRASS	905B	015	1-25	High Pressure	24" (std)	10" (std)	1-25	High Pressure	24" (std)	10" (std)	000 (No CGA)
	905BV	050		Cylinder	36"	5"		Cylinder	36"	5"	280 (Brass Only)
	905BA - Alarm	125		Liquid	72"			Liquid	72"		320
	905BVA - Valves and Alarm	250		Cylinder				Cylinder			326
	905BP - Inlet Purge	500									330 (SS Only)
	905BPA - Inlet Purge and Alarm										346
	905S										350
	905SV - Isolation Valve										500 (Brass Only)
	905SA - Alarm										540
	905SVA - Valve and Alarm										580
316L SS	905SP - Purge										590
	905SPA - Purge and Alarm										660 (SS Only) 705 (SS Only)



# CRYOGENIC HEADER MANIFOLDS



Harris cryogenic header manifolds are designed specifically to supply liquid nitrogen to freezers. The manifolds have cryogenic service safety relief valves to prevent the pipe failure if liquid nitrogen becomes trapped between shut-off valve and the freezer solenoid valves.

The header is made from 3/8" brass pipe. The safety relief valves are extended to a height ensuring they do not become encased in ice if manifold develops exterior ice coating. Manifolds come complete with cryogenic hoses, cryo check valves, and 295 adapters. All manifolds come standard with wall mounting hardware.

In addition, the 2, 3, and 4 Dewar cylinder models come with optional dispensing hose equipped with a phase separator.

## SPECIFICATIONS

- Header - 3/8" extra heavy brass pipe
- Safety Relief Valve Setting - 75 PSIG
- Inlet Connection - CGA 295 Female swivel
- Output Connections - CGA 295 Male

## ORDERING INFORMATION

PART NO.	DESCRIPTION	CONNECTION HOSE TO FREEZER
4703009	Two N2 Dewar source x one freezer	Yes
4703012	Two N2 Dewar source x one freezer w /one Liquid N2 withdrawal port CGA 295	Yes
4703010	Three N2 Dewar source x one freezer	Yes
4703011	Four N2 Dewar source x one freezer	Yes
4703013	Three N2 Dewar source x one freezer w/one Liquid N2 withdrawal port CGA 295	
9030266	Phase Separator	
9030139	Nut, 1/2 x 3/8 Flare Male NPT Brass	
9030146	Hose, Cryo,6',CGA 295 Ends - Other lengths available	
9030261	Hose, 6'Od CGA295 CFCL VJ Transfer, Vacuum Jacketed Transfer Line, 3/8" ID non-braided inner hose, 1.50" OD Braided Outer Jacket, 159 PSI MAWP, Super Insulation, SV-9 Pump-out Port & Plug with Protective Guard, CGA 295 Female Flare Each End - Other lengths available	

# MODULAR HIGH PRESSURE HEADER - MANIFOLDS



Modular High – Pressure Header Manifolds are a unique design using a high integrity method to connect sections to form a high pressure manifold without welding or brazing metals. The design allows for fast delivery and easy assembly into a straight, L or U shape configuration. These manifolds may also be reconfigured in the field to add or remove sections or reconfigure the shape of the manifold. Each station is equipped with a stainless steel flex hose, manual diaphragm isolation valve and a check valve at the CGA cylinder connection.

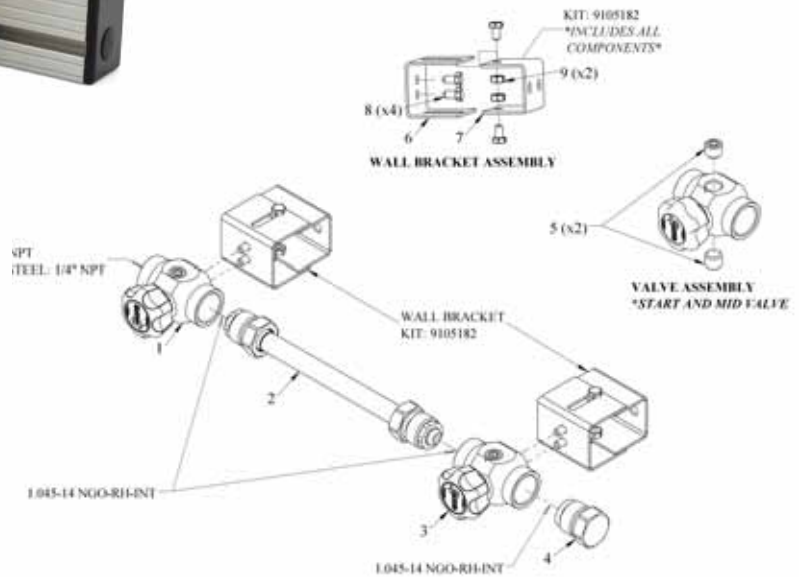

## FEATURES

- Diaphragm Isolation Valves allows for shut off at each cylinder station and maintains gas purity
- Easy station add on when additional cylinders are required
- Wall mounting brackets attached to each valve for trouble free wall mounting assembly
- Can be configured in a straight, L or U shape design
- Can be configured 5" or 10" center to center

## SPECIFICATIONS

Max Rated Inlet Pressure: 4350 psig  
 Ambient Operating Temperature: -40F to 160 F

## MATERIALS

Manifold	Brass or stainless steel
Header Valve	Brass or stainless steel
Valve Seat	PCTFE
Pigtails	316 stainless steel
CGAs	Brass or stainless steel with integrated check valve
Check Valve Seal	Viton
Valve Spring	302 Stainless Steel
1st Stage Seat	PTFE
2nd Stage Seat	Neoprene



# SG 770

## GENERATOR BACK-UP PANEL



Model SG 770 provides a continuous backup supply of gas in case of generator failure or loss of power. The system automatically switches to a backup cylinder of gas when the generator supply pressure drops below a preset value. The process will automatically reverse when the gas supplied by the generator returns to a normal level. All units include the following:

- 0-125 PSIG line regulator
- High leak integrity diaphragm isolation valves
- Flexible hose for attaching to the cylinder
- Reverse flow check valve

### FEATURES

- Includes 36" flexible pigtail with integrated reverse flow check valve
- 1/4 turn isolation shut off valves included
- 1/4" Swagelok® outlet connection
- 1/4" Swagelok® inlet connection with reverse flow check valve
- Available for Air, Nitrogen or Hydrogen gas service

### MATERIALS

Regulator	Brass
Diaphragm	316 Stainless Steel
Seat	PTFE Teflon
Pigtail	Armor Shielded with SS Inner Core
Panel	302 SS

### SG 770 ORDERING INFORMATION

PART NO.	MODEL NO.	GAS SERVICE
4702981	SG 770-350	Hydrogen
4702982	SG 770-580	Nitrogen
4702983	SG 770-590	Air (Industrial)
4702984	SG 770-346	Air

# SG 770

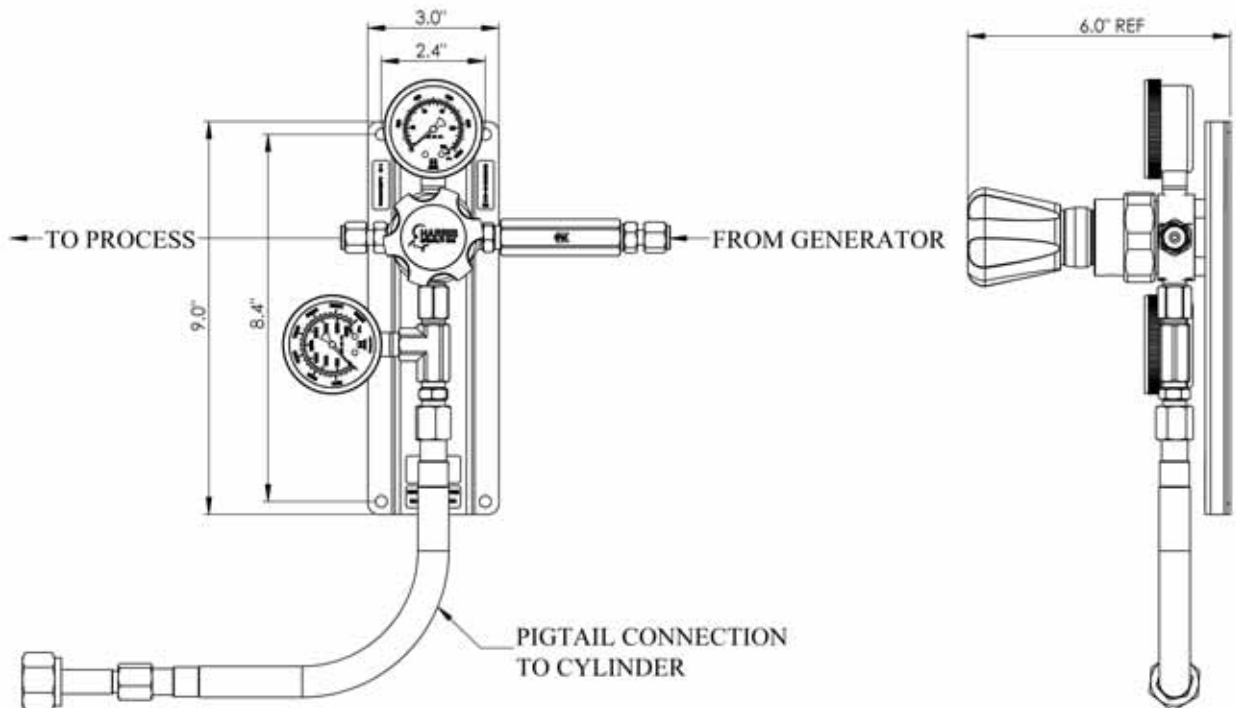
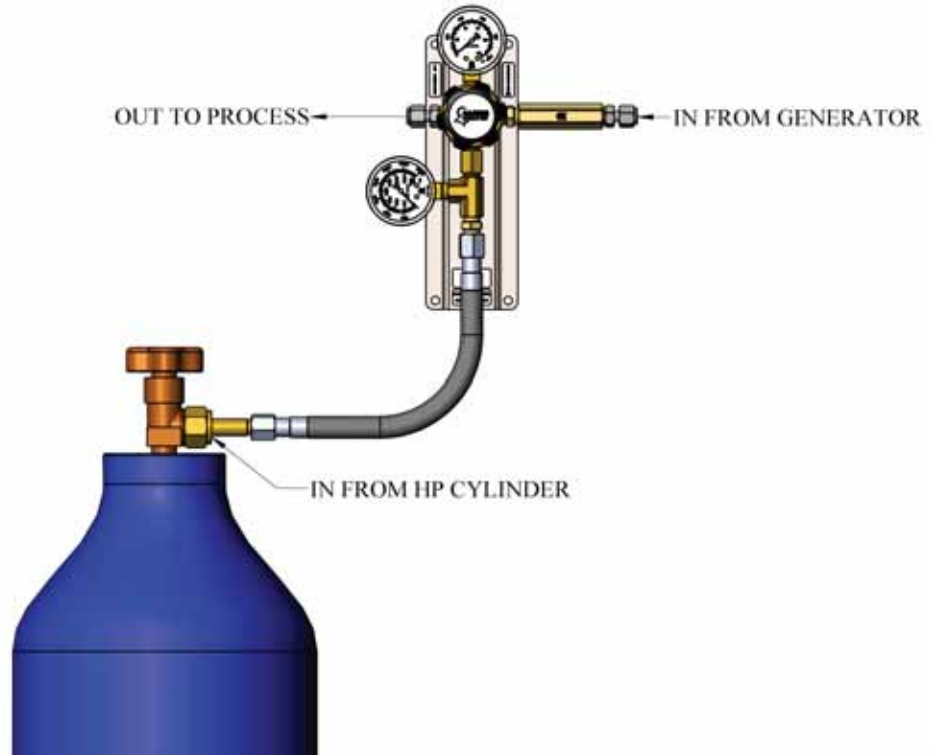

# POINT OF USE PANEL



Model CNT03X03X03X shown

The Harris PNL panels are designed to provide a useful and economical way to control pressure at the point of use in a process or laboratory application.

The Harris Model PNL is designed with chrome plated brass bar stock (723C) or stainless steel bar stock (743) ultra high purity regulators. These regulators come equipped with a quarter turn positive shut off packless diaphragm valve.

In addition, Harris can offer Point of Use Gas Panels with the regulator's inlet ports tied together for multiple outlet pressures using the same gas to different applications.

## FEATURES

- Increased control of delivery pressure to the point of use
- Visual indicator of pressure at the process
- On/off packless diaphragm valve with positive shutoff
- 1/4 turn outlet valve with visual on/off ring
- Ability to control multiple gases in a small footprint
- Wall or benchtop mounting options
- 316L stainless steel diaphragm eliminates contamination from diffusion or outgassing
- One piece encapsulated seat design includes a sintered filter to protect the seat from particulate contamination
- 2" dual scale gauge (psi/bar)
- Designed to 1 x 10<sup>-9</sup> cc/sec. inboard helium leak rate to maintain gas purity levels

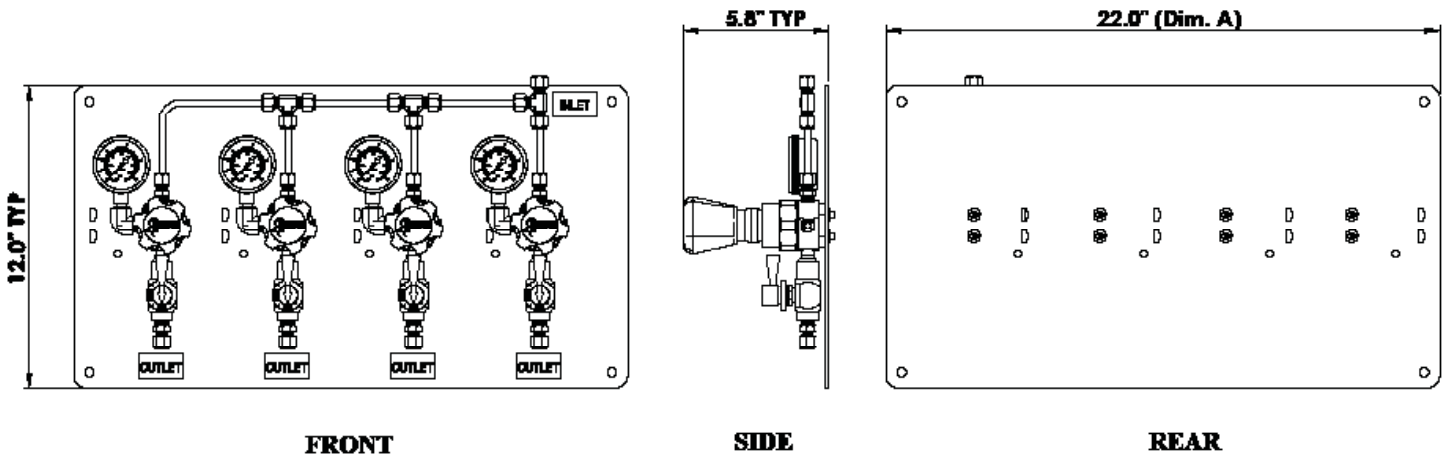

Number of Stations	Width (Dim. A)
1	7"
2	12"
3	17"
4	22"





# PANEL ORDERING INFORMATION

SERIES	MATERIAL	PANEL TYPE	GAS SERVICE POSITION 1	PRESSURE POSITION 1	OUTLET POSITION 1	GAS SERVICE POSITION 2	PRESSURE POSITION 2	OUTLET POSITION 2	GAS SERVICE POSITION 3	PRESSURE POSITION 3	OUTLET POSITION 3	GAS SERVICE POSITION 4	PRESSURE POSITION 4	OUTLET POSITION 4
--------	----------	------------	------------------------	---------------------	-------------------	------------------------	---------------------	-------------------	------------------------	---------------------	-------------------	------------------------	---------------------	-------------------

Example: 4 regulator stainless panel two stations for hydrogen at 15 and 50 psi, two stations for air at 125 psi, all with 1/4" tube fittings

PNL	S	T	K	1	X	K	2	X	B	3	X	B	3	X
PNL	C - Chrome Plated Brass Model HP723C Regulator	NT - Inlet not tied	A - Acetylene	1 - 15 psi	X - 1/4 Tube Fitting	A - Acetylene	1 - 15 psi	X - 1/4 Tube Fitting	A - Acetylene	1 - 15 psi	X - 1/4 Tube Fitting	A - Acetylene	1 - 15 psi	X - 1/4 Tube Fitting
	S - (316L SS) Model HP743 Regulator	T - Inlet tied	B - Air	2 - 50 psi	Y - 1/8 Tube Fitting	B - Air	2 - 50 psi	Y - 1/8 Tube Fitting	B - Air	2 - 50 psi	Y - 1/8 Tube Fitting	B - Air	2 - 50 psi	Y - 1/8 Tube Fitting
			C - Ammonia*	3 - 125 psi	Z - 3/8 Tube Fitting	C - Ammonia*	3 - 125 psi	Z - 3/8 Tube Fitting	C - Ammonia*	3 - 125 psi	Z - 3/8 Tube Fitting	C - Ammonia*	3 - 125 psi	Z - 3/8 Tube Fitting
			D - Argon	4 - 250 psi		D - Argon	4 - 250 psi		D - Argon	4 - 250 psi		D - Argon	4 - 250 psi	
			E - Carbon Dioxide			E - Carbon Dioxide			E - Carbon Dioxide			E - Carbon Dioxide		
			F - Carbon Monoxide			F - Carbon Monoxide			F - Carbon Monoxide			F - Carbon Monoxide		
			H - Chlorine *			H - Chlorine *			H - Chlorine*			H - Chlorine *		
			I - Ethylene			I - Ethylene			I - Ethylene			I - Ethylene		
			J - Helium			J - Helium			J - Helium			J - Helium		
			K - Hydrogen			K - Hydrogen			K - Hydrogen			K - Hydrogen		
			L - Methane			L - Methane			L - Methane			L - Methane		
			M - Neon			M - Neon			M - Neon			M - Neon		
			N - Nitric Oxide *			N - Nitric Oxide *			N - Nitric Oxide *			N - Nitric Oxide *		
			O - Nitrogen			O - Nitrogen			O - Nitrogen			O - Nitrogen		
			P - Nitrous Oxide			P - Nitrous Oxide			P - Nitrous Oxide			P - Nitrous Oxide		
			R - Oxygen			R - Oxygen			R - Oxygen			R - Oxygen		
			S - Propane			S - Propane			S - Propane			S - Propane		
			T - Propylene			T - Propylene			T - Propylene			T - Propylene		
			U - Sulfur Dioxide *			U - Sulfur Dioxide *			U - Sulfur Dioxide *			U - Sulfur Dioxide *		
			V - Sulfur Hexafluoride			V - Sulfur Hexafluoride			V - Sulfur Hexafluoride			V - Sulfur Hexafluoride		
			W - Xenon			W - Xenon			W - Xenon			W - Xenon		

\*Only available in stainless steel

# FLOWMETER SELECTION GUIDE



In selecting a flowmeter, the following should be taken into consideration.

## Materials Compatibility

As with all gas handling equipment, care must be taken to ensure that the materials used to construct the flowmeter are compatible with the service gas. Each of the flowmeters shown in this catalog is provided with a list of its “Materials of Construction”. This information should be used with the gas compatibility data on page 107.

## Pressure and Temperature Ratings

The flowmeter must be capable of handling pressures and temperatures required by the particular application. Maximum operating pressures and temperatures are provided for each flowmeter under “Specifications.”

## Measuring Range

Flowmeters have specific measuring ranges associated with them. These ranges will vary depending on the flowmeter model as well as the tube and float combination selected. Obviously, the specific flowmeter chosen must be capable of measuring in the flow range required by the process. In general and for the best accuracy, it is suggested that the flowmeter be sized for operation in the upper part of its range.

## Accuracy

The flowmeter should be accurate to the degree required by the application. Accuracy specifications are listed for each of our flowmeters. Generally, this will be + 5% for high accuracy or ±10% for high flow of full scale. Full scale accuracy means that the accuracy specification is based on the flowmeter’s maximum capacity. For example, a meter with a measuring range of 1-10 SPLM and an accuracy specification of ± 10% will have an actual accuracy of ± 1 SPLM across its entire range that is 10% of the maximum capacity of 10 SPLM.

## Repeatability

In many gas processes, the ability to duplicate flow measurements over time is more important than the absolute accuracy of the readings. The repeatability specification shown for each flowmeter refers to the degree to which a meter will repeat a previous flow reading. In general, variable area flowmeters have very good repeatability, many as high as ± 0.25% of full scale for the SG 1050 and SG 1000.

## Metering Valves

Flowmeters only measure flow. If adjustments to flow rates are required, a flowmeter equipped with a metering valve should be selected. A standard metering valve is included on the inlet for each flowmeter, optional high accuracy valves are available on the SG 1050 and SG 1000 flowmeters.

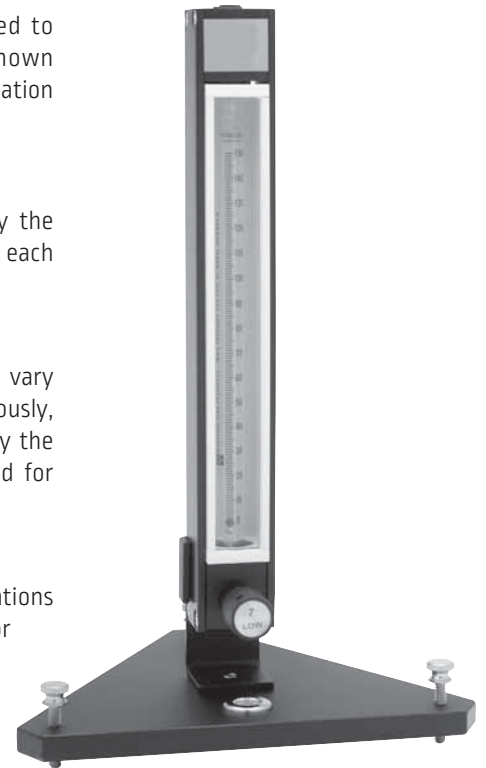

\* Shown with optional base plate assembly and 150 MM flow tube

## FLOWMETER SELECTION GUIDE

MODEL NO.	FLOW RANGES (AIR)	BRASS	ALUMINUM	STAINLESS STEEL	TUBE SCALE	CATALOG PAGE NO.
SG 1000	0.02 - .24 SCFH to 10 - 150 SCFH	N/A	X	X	65 MM	pg. 85
SG 1050	6 - 150 SCCM to 2.4 - 44 SLPM	N/A	X	X	150 MM	pg. 84
SG 1100	0.5-4 SCFM to 1-15 SCFM	X	N/A	X	70 MM	pg. 86
SG 1127 1-16 SCFM	0.2 - 4 SCFM to	X	N/A	X	127 MM	pg. 86

# FLOWMETER SELECTION GUIDE



## How they work:

Flowmeters are used in gas systems to indicate the rate of flow of the gas. They can also control the rate of flow if they are equipped with a flow control valve. Rotameters are a particular kind of flowmeter based on the variable area principle. They provide a simple, precise and economical means of indicating flow rates in fluid systems. This variable area principle consists of three basic elements: A uniformly tapered flow tube, a float and a measured scale.

A control valve may be added if flow control is also desired.

In operation, the rotometer is positioned vertically in the gas system with the smallest diameter end of the tapered flow tube at the bottom. This is the gas inlet. The float, typically spherical, is located inside the flow tube, and is engineered so that its diameter is nearly identical to the flow tube's inlet diameter.

When fluid gas is introduced into the tube, the float is lifted from its initial position at the inlet, allowing the gas to pass between it and the tube wall. As the float rises, more and more gas flows by the float because the tapered tube's diameter is increasing. Ultimately, a point is reached where the flow area is large enough to allow the entire volume of the gas to flow past the float. This flow area is called the annular passage. The float is now stationary at that level within the tube, as its weight is being supported by the gas forces which caused it to rise. This position corresponds to a point on the tube's measurement scale and provides an indication of the gas flow rate.

One way to change the capacity, or flow range of a rotometer is to change the float material, and thus its density, while keeping the flow tube and float size constant. Floats which are made from less dense materials will rise higher in the tube and therefore will yield lower flow capacities for the same diameter flow tube.

## Selecting the right flowmeter size:

There are certain factors which affect the measurement of a gas flow rate with a rotameter. The gas temperature, pressure and specific gravity all impact gas flow measurements.

Flow capacities [ranges] for the flowmeters described in this catalog are given for air at standard conditions -- 14.7 PSIA (101.3 kPa Abs) and 70° F (21° C). Sizing a meter for a gas other than air, or for your specific application pressure and/or temperature, requires that you first determine the equivalent flow capacity in air at standard conditions. Once determined, the flow capacity tables in this catalog can be applied directly. Reference scale tables can be requested for each flowmeter ordered which will provide conversion to your desired fluid or conditions.

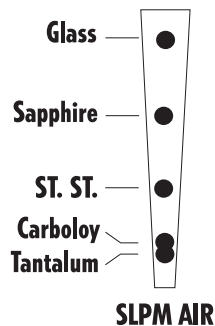

Note that for flowmeters calibrated at standard conditions with a valve on the inlet, readings on the tube are correct provided that the outlet pressure is close to atmospheric. When the valve is on the outlet, readings are correct if the inlet gas pressure is equal to the pressure for which the tube was calibrated.

## Flow Rate Factors for Gases other than Air

Acetylene .....	0.95	Halocarbon-11 .....	2.18	Hydrogen Chloride .....	1.13
Air .....	1.00	Halocarbon-12 .....	2.05	Hydrogen Sulfide .....	1.08
Ammonia .....	0.77	Halocarbon-13 .....	1.90	Isobutane .....	1.42
Argon .....	1.18	Halocarbon-13B .....	2.27	Isobutylene .....	1.39
1-3 Butadiene .....	1.37	Halocarbon-14 .....	1.74	Methane (Natural Gas) .....	0.75
Butane .....	1.42	Halocarbon-21 .....	1.89	Methyl Fluoride .....	1.09
1-Butene .....	1.39	Halocarbon-22 .....	1.73	Monomethylamine .....	1.04
Carbon Dioxide .....	1.23	Halocarbon-23 .....	1.56	Neon .....	0.83
Carbon Monoxide .....	0.98	Halocarbon-113 .....	2.54	Nitrogen .....	0.98
Chlorine .....	1.57	Halocarbon-114 .....	2.43	Nitrogen Dioxide .....	1.60
Cracked Ammonia .....	0.54	Halocarbon-116 .....	2.18	Nitrous Oxide .....	1.23
Cyclopropane .....	1.21	Halocarbon-115 .....	2.31	Oxygen .....	1.05
Difluoroethane .....	1.51	Halocarbon-142B .....	1.86	Propane .....	1.23
Dimethyl Ether .....	1.26	Halocarbon-152A .....	1.51	Propylene .....	1.21
Ethane .....	1.02	Helium .....	0.37	Sulfur Dioxide .....	1.50
Ethylene .....	0.98	Hydrogen .....	0.26	Sulfur Hexafluoride .....	2.25

Floats made from more dense materials will rise less thereby yielding higher flow capacities. Relative flow capacities for some common float materials are shown above.

Another way to change the capacity is to change the diameter of the flow tube and the size of the float.



# SG 1050

Flowmeter

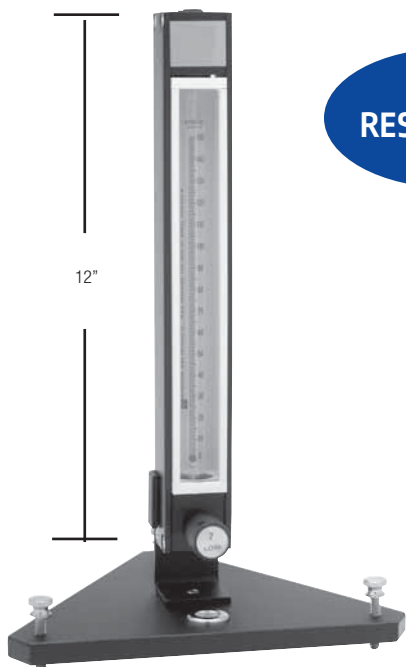

**HIGH  
RESOLUTION**

The SG 1050 Series Flowmeters provide the most accurate indication and precise control of gases available for a wide range of applications.

All SG 1050 Series glass metering tubes have integral float guides to ensure a guaranteed  $\pm 5\%$  of full scale accuracy. The meters are available in a range of 150 mm reference indicating scales.

## FEATURES

- High resolution 150mm scale length
- Precision tapered, fluted metering tube
- Standard front panel mounting requires minimum hardware easy installation, quick access
- Simplified, direct acting, nonrotating compression plug for quick and easy tube sealing

## SPECIFICATIONS

Pressure Rating: ..... 200 PSIG maximum operating pressure

Temperature Rating: 250°F maximum operating temperature

Accuracy: .....  $\pm 5\%$  of full scale flow rate

Repeatability: ..... 0.25% of scale reading

Range: 10 to 1, [i.e., 100% to 10% of full scale] mm or linear flow with conversion curves and/or factors

Shipping Weight: ..... 1 lb - Flowmeter  
1 lb - Base

## RELATED OPTIONS

**BRASS ADAPTOR KIT** for direct attachment to regulator

P/N: 9100919

**STAINLESS STEEL ADAPTOR KIT** P/N: 9101232

Shown with optional base plate assembly and 150 MM flow tube

## MATERIALS

End Blocks, Fittings and Internal Parts	Aluminum or 316 stainless steel
Seal Materials	Buna-N or Viton – standard
Metering Tube	Borosilicate glass enclosed
Float Materials	Black glass and 316 stainless steel – standard

## ORDERING INFORMATION

SG 1050	-	xx(xx)	-	xx(xx)	-	xxx	-	xx	-	xxx
MODEL NO.		END BLOCKS/ SEAL MATERIAL		VALVE TYPES		INLET/OUTLET CONNECTIONS		FLOW TUBE (CAPACITIES) AIR		OPTIONS
SG 1050		1. Aluminum with Buna-N Seals		1. Utility Valve on Inlet		1. 1/8" NPT Female		1. 6-150 SCCM 2. 10-270 SCCM 3. 38-840 SCCM 4. 88-1800 SCCM 5. .23-4.6 SLPM 6. .4-7.6 SLPM 7. .88-16 SLPM 8. 2.4-44 SLPM		1. Base Plate Assembly P/N: 4300320
		2. Stainless Steel with Viton Seals								

Standard units include valve on inlet and 1/8" NPT connection.  
Note: Be sure to request calibration data for the gas(es) you will be measuring.





# SG 1000

Technical Specifications

The SG 1000 Series Flowmeters incorporate the innovative design of the SG 1050 in a more compact unit without reducing standards of accuracy. The same  $\pm 5\%$  full scale accuracy is guaranteed for the 65mm scale length of these flowmeters.

The SG 1000 Series flowmeters are direct reading for air. These flow tubes are fluted to provide better float stability.

## FEATURES

- Precision tapered, fluted metering tube
- Reflective plastic background and 1.5 X magnification lens for excellent readability
- Safety blow-out back panel
- Full 10 to 1 (100% to 10% full scale) metering range
- Low pressure drop for increased flow rates at low feed pressures

## SPECIFICATIONS

Pressure Rating: .....200 PSIG maximum operating pressure

Temperature Rating: ..200°F maximum operating temperature

Accuracy: .....  $\pm 5\%$  of full scale flow rate

Repeatability: .....0.25% of scale reading

Range: .....10 to 1, (i.e., 100% to 10% of full scale)

Shipping Weight: .....1 lb - Flowmeter  
1 lb - Base

**COMPACT**

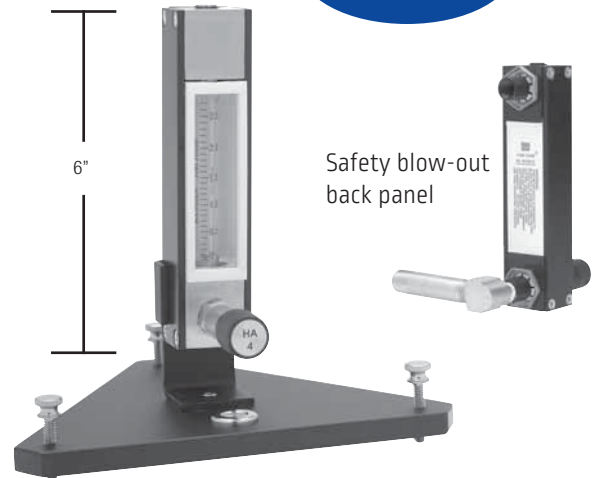

Shown with optional base plate assembly and 65 MM flow tube

## MATERIALS

End Blocks,	Aluminum or 316 stainless steel
Fittings and Internal Parts	Aluminum or 316 stainless steel
Seal Materials	Buna-N or Viton – standard
Metering Tube	Borosilicate glass enclosed
Float Materials	Black glass and 316 stainless steel – standard

**BRASS ADAPTOR KIT** for direct attachment to regulator P/N: 9100919  
**STAINLESS STEEL ADAPTOR KIT** P/N: 9101232

## ORDERING INFORMATION

SG 1000	-	XX	-	xx{xx}	-	xx{xx}	-	XXX	-	XXX
MODEL NO.		END BLOCKS/ SEAL MATERIAL		VALVE TYPES		INLET/OUTLET CONNECTIONS		FLOW TUBE (CAPACITIES) AIR		OPTIONS
SG 1000		1. Aluminum with Buna-N Seals		1. Utility Valve on Inlet		1. 1/8" NPT Female		1. .02-.24 SCFH 2. .05-.65 SCFH 3. .2-1.1 SCFH 4. .4-2.2 SCFH 5. .2-2.8 SCFH 6. .2-4.4 SCFH 7. 1-11 SCFH 8. 2-20 SCFH 9. 5-55 SCFH 10. 10-100 SCFH 11. 10-150 SCFH		1. Base Plate Assembly P/N 4300320
		2. Stainless Steel with Viton Seals								

Standard units include valve on inlet and 1/8" NPT connection.  
Note: Be sure to request calibration data for the gas(es) you will be measuring.



THE HARRIS PRODUCTS GROUP  
www.harrisproductsgroup.com

Orders: 1.800.733.4043

# SG 1100, SG 1127

Flowmeter

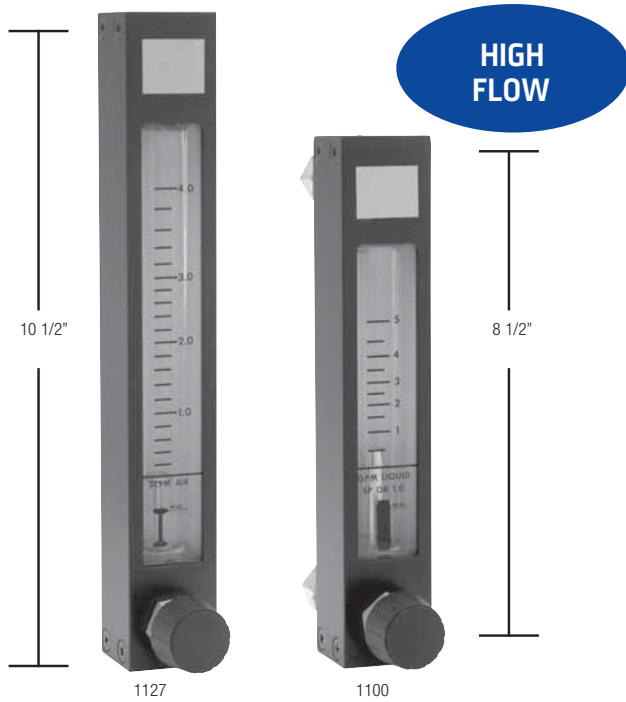

The Model SG 1100 and SG 1127 Series Flowmeters are offered as a simplified solution to the problem of gas flow indication at higher capacity levels than the SG 1050 and SG 1000 Series Flowmeters. These meters are designed to withstand the physical abuse and environmental corrosion of industrial applications.

The SG 1100 is available in several ranges of 70mm direct reading scales, and the SG 1127 is available in 127mm direct reading scales.

## FEATURES

- Precision tapered, fluted metering tube
- Fully protected assembly using aluminum meter case
- Unobstructed flow path area for low pressure drop increases available flow rates at low feed pressures
- Precision machined float
- Spring float stops absorb line shock
- Float/Scale correlation symbol and float reading edge instructions permanently screened on meter window
- Standard units include valve on inlet and 3/8 NPT connection

## SPECIFICATIONS

Pressure Rating: 150 PSIG maximum operating pressure

Temperature Rating: 250°F maximum operating temperature

Accuracy: ±10% of full scale flow rate

Range: 10 to 1, i.e., 100% to 10% of full scale

Shipping Weight: 2 lb.

## MATERIALS

Wetted End Blocks, Fittings and Internal Parts	Brass or 316 stainless steel
Seal Materials	Buna-N or Viton – standard
Metering Tube	Borosilicate glass
Float Material	316 stainless steel

## ORDERING INFORMATION

SG 1100 - xx(xx) - xx(xx) - XXX - XX  
 SG 1127

MODEL NO.	END BLOCKS/ SEAL MATERIAL	VALVE TYPES	INLET/OUTLET CONNECTIONS	1100 or 1127 FLOW TUBE (CAPACITIES) AIR
SG 1100	1. Brass with Buna-N Seals 3. 1-12 scFm	1. Utility Valve on Inlet * 2. 3/8" FNPT * 3. 0.5-11 scFm	1. 0.5-4 scFm 2. 1-9 scFm	1. 0.2-4 scFm 2. 0.5-9 scFm
SG 1127	2. Stainless Steel with Viton Seals		4. 1-15 scFm	4. 1-16 scFm

\* Standard units include valve on inlet and 3/8 FNPT connection  
 Note: Be sure to request calibration data for the gas(es) you will be measuring.







# PURGE ASSEMBLIES

## REGULATOR PURGING

Regulator purging is not always given the attention it deserves in the use of high purity, calibration and other specialty gases. The additional cost of proper purging equipment is sometimes seen as unnecessary. Users must realize, however, that atmospheric contamination into a specialty gas system results every time an empty cylinder is changed out, or every time a regulator is disconnected and reconnected. As a consequence of this, application results will also be negatively affected by the contaminated gas stream. In order to maintain system integrity and obtain the best results possible, the user should purge all regulators. It should be remembered that maintaining the purity of the gas between the cylinder and its end use is dependent on the quality of connecting lines, valves and other equipment as well as the purging procedure.

Purging of regulators is often not done at all, or, is done by simply allowing an arbitrary amount of gas to flow through the regulator. The shortcoming of this method is that in virtually all regulators there are internal "dead" pockets which tend to hold contaminants. Just as a smoke detector in a house cannot function properly if it is installed too close to the junction of the wall and the ceiling, regulator "dead" pockets tend to be unaffected by the flow of purge gas. Better results will be achieved by dilution purging. Dilution purging can be accomplished by alternately pressurizing and depressurizing the regulator with the purge gas. The following procedure details this method.

## DID YOU KNOW?

*"maintaining the purity of the gas between the cylinder and its end use is dependent on the quality of connecting lines, valves and other equipment as well as the purging procedure."*

*- Matt Paradiso*

1. Install a tee or cross purge device between the regulator and the cylinder or a tee purge device between the regulator and the downstream instrument. The main trunk should run to the regulator or instrument and the purge branch should be vented in a safe manner for the gas used. Special precautions will be necessary when using pyrophoric, toxic, corrosive, flammable or oxidizing gases. See your local gas supplier, or contact The Harris Products Group for additional information.
2. Turn the regulator adjustment valve to the fully closed position. Then, close the vent valve and the valve at the instrument and open the valve on the outlet side of the regulator.
3. Slowly open and close the cylinder valve, which will pressurize the inlet side of the regulator to cylinder pressure.
4. Adjust the regulator to the appropriate delivery pressure, then open the vent valve to bleed off the regulator pressure.
5. Steps 2 through 4 represent one purge cycle. This cycle should be repeated 3 to 5 times to ensure that the regulator and connecting line are both properly purged.

Note: The above procedure is only one type of purging. Information regarding purge assemblies and alternate methods of purging are available from The Harris Products Group.



# TYPICAL PURGE ASSEMBLIES



## BLOCK AND BLEED PURGE ON REGULATOR OUTLET

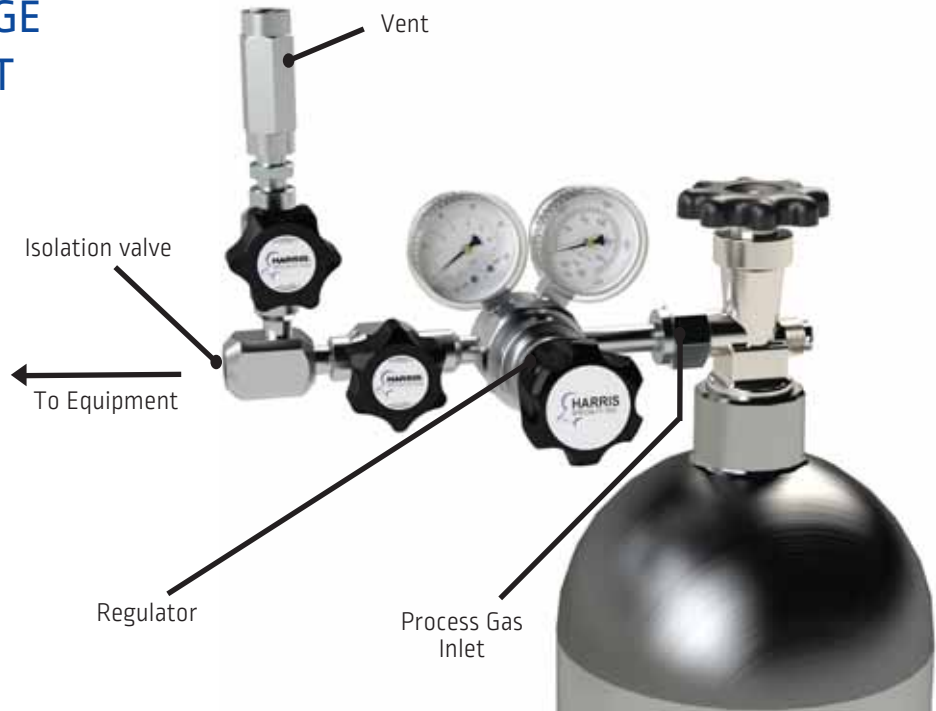

## CROSS PURGE ON REGULATOR INLET WITH PURGE GAS LINE AND VENT

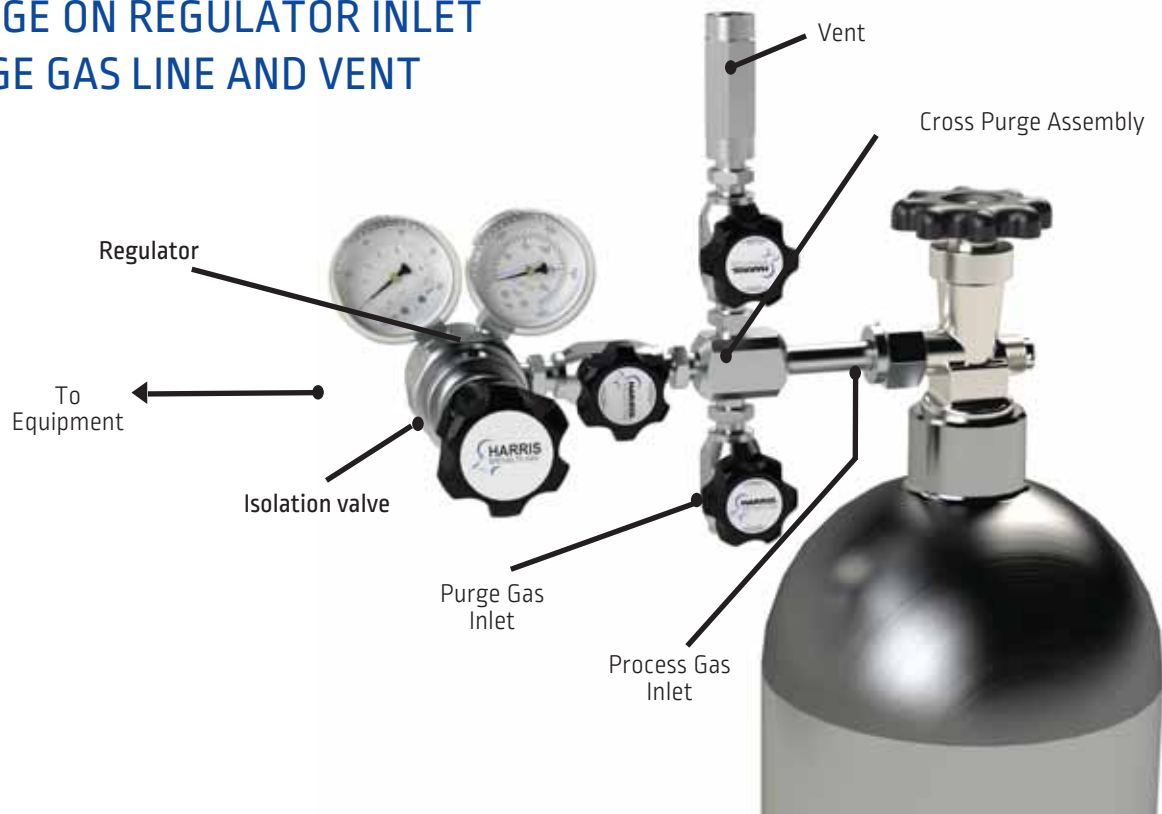



# PURGE ASSEMBLIES

Straight & Tee Type

Purging should be performed before system start-ups to remove contaminants such as air and water vapor from the gas delivery system. Also, purging should be done before changing out toxic and corrosive gas cylinders.

## STRAIGHT PURGE ASSEMBLIES

The straight purge assembly is connected to the regulator body via an auxiliary high pressure port. The gas is vented through the body to a downstream location.



P/N: 4300376

PART NO.	MATERIAL	DESCRIPTION
4300376	Brass	Straight Purge
4300373	Stainless Steel	Straight Purge

## TEE PURGE ASSEMBLIES

The tee purge can be connected between the cylinder and the regulator, or, between the regulator and the instrument. The system can be flushed with the purging gas to remove contaminants prior to start-up or after a cylinder change. Available with multiturn or 1/4 turn instrument valve.



P/N: 4301413

PART NO.	MATERIAL	DESCRIPTION
4300375	Brass	Tee Purge- Assembly, 1/4 NPT, No CGA
4301409	Brass	Tee Purge- Assembly, CGA 320 W/CV
4301410	Brass	Tee Purge- Assembly, CGA 346 W/CV
4301411	Brass	Tee Purge- Assembly, CGA 350 W/CV
4301412	Brass	Tee Purge- Assembly, CGA 540 W/CV
4301413	Brass	Tee Purge- Assembly, CGA 580 W/CV
4301414	Brass	Tee Purge- Assembly, CGA 590 W/CV
4301473	Brass	Tee Purge- Assembly, 1/4 TRN CGA 320 W/CV
4301474	Brass	Tee Purge- Assembly, 1/4 TRN CGA 346 W/CV
4301475	Brass	Tee Purge- Assembly, 1/4 TRN CGA 350 W/CV
4301476	Brass	Tee Purge- Assembly, 1/4 TRN CGA 540 W/CV
4301477	Brass	Tee Purge- Assembly, 1/4 TRN CGA 580 W/CV
4301478	Brass	Tee Purge- Assembly, 1/4 TRN CGA 590 W/CV
4300372	Stainless Steel	Tee Purge- Assembly, 1/4 NPT, No CGA
4301433	Stainless Steel	Tee Purge- Assembly, CGA 320 W/CV
4301434	Stainless Steel	Tee Purge- Assembly, CGA 346 W/CV
4301435	Stainless Steel	Tee Purge- Assembly, CGA 350 W/CV
4301436	Stainless Steel	Tee Purge- Assembly, CGA 540 W/CV
4301437	Stainless Steel	Tee Purge- Assembly, CGA 580 W/CV
4301438	Stainless Steel	Tee Purge- Assembly, CGA 660 W/CV
4301439	Stainless Steel	Tee Purge- Assembly, CGA 330 W/CV
4301440	Stainless Steel	Tee Purge- Assembly, CGA 340 W/CV
4301497	Stainless Steel	Tee Purge- Assembly, 1/4 TRN CGA 320 W/CV
4301498	Stainless Steel	Tee Purge- Assembly, 1/4 TRN CGA 346 W/CV
4301499	Stainless Steel	Tee Purge- Assembly, 1/4 TRN CGA 350 W/CV
4301500	Stainless Steel	Tee Purge- Assembly, 1/4 TRN CGA 540 W/CV
4301501	Stainless Steel	Tee Purge- Assembly, 1/4 TRN CGA 580 W/CV
4301502	Stainless Steel	Tee Purge- Assembly, 1/4 TRN CGA 660 W/CV
4301503	Stainless Steel	Tee Purge- Assembly, 1/4 TRN CGA 330 W/CV
4301504	Stainless Steel	Tee Purge- Assembly, 1/4 TRN CGA 240 W/CV



# CROSS PURGE ASSEMBLIES



## CROSS PURGE ASSEMBLIES

The cross purge assembly is used between the cylinder and the regulator. In addition to the features on the tee purge, the cross purge assembly allows the use of inert purge gas. Cross purges are available with multi turn or 1/4 turn instrument valves.

PART NO.	MATERIAL	DESCRIPTION
4300377	Brass	Cross Purge- Assembly, 1/4 NPT, No CGA
4301415	Brass	Cross Purge- Assembly, CGA 320 W/CV
4301416	Brass	Cross Purge- Assembly, CGA 346 W/CV
4301417	Brass	Cross Purge- Assembly, CGA 350 W/CV
4301418	Brass	Cross Purge- Assembly, CGA 540 W/CV
4301419	Brass	Cross Purge- Assembly, CGA 580 W/CV
4301420	Brass	Cross Purge- Assembly, CGA 590 W/CV
4301479	Brass	Cross Purge- Assembly, 1/4 TRN CGA 320 W/CV
4301480	Brass	Cross Purge- Assembly, 1/4 TRN CGA 346 W/CV
4301481	Brass	Cross Purge- Assembly, 1/4 TRN CGA 350 W/CV
4301482	Brass	Cross Purge- Assembly, 1/4 TRN CGA 540 W/CV
4301483	Brass	Cross Purge- Assembly, 1/4 TRN CGA 580 W/CV
4301484	Brass	Cross Purge- Assembly, 1/4 TRN CGA 590 W/CV
4300374	Stainless Steel	Cross Purge- Assembly, 1/4 NPT, No CGA
4301441	Stainless Steel	Cross Purge- Assembly, CGA 320 W/CV
4301442	Stainless Steel	Cross Purge- Assembly, CGA 346 W/CV
4301443	Stainless Steel	Cross Purge- Assembly, CGA 350 W/CV
4301444	Stainless Steel	Cross Purge- Assembly, CGA 540 W/CV
4301445	Stainless Steel	Cross Purge- Assembly, CGA 580 W/CV
4301446	Stainless Steel	Cross Purge- Assembly, CGA 660 W/CV
4301447	Stainless Steel	Cross Purge- Assembly, CGA 330 W/CV
4301448	Stainless Steel	Cross Purge- Assembly, CGA 320 W/CV
4301505	Stainless Steel	Cross Purge- Assembly, 1/4 TRN CGA 320 W/CV
4301506	Stainless Steel	Cross Purge- Assembly, 1/4 TRN CGA 346 W/CV
4301507	Stainless Steel	Cross Purge- Assembly, 1/4 TRN CGA 350 W/CV
4301508	Stainless Steel	Cross Purge- Assembly, 1/4 TRN CGA 540 W/CV
4301509	Stainless Steel	Cross Purge- Assembly, 1/4 TRN CGA 580 W/CV
4301510	Stainless Steel	Cross Purge- Assembly, 1/4 TRN CGA 660 W/CV
4301511	Stainless Steel	Cross Purge- Assembly, 1/4 TRN CGA 330 W/CV
4301512	Stainless Steel	Cross Purge- Assembly, 1/4 TRN CGA 240 W/CV

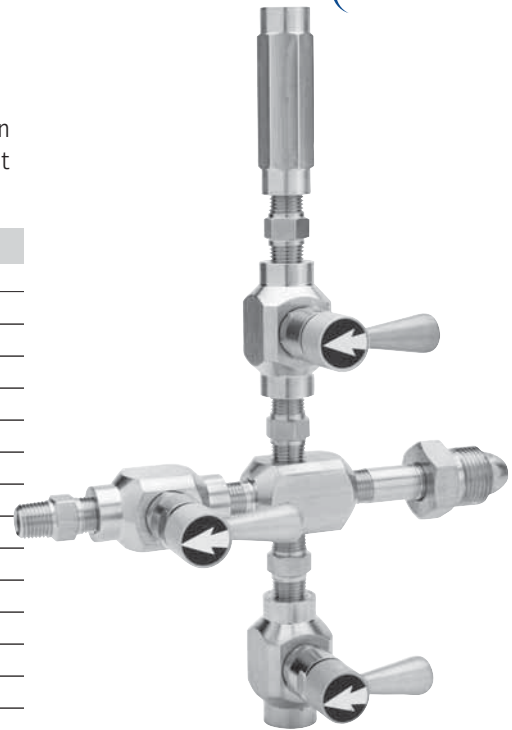

P/N: 4301509

## BLOCK & BLEED PURGE ASSEMBLIES

Block and bleed purges are typically used in manifolds or other applications where atmospheric contaminants need to be purged after cylinder change out. The purges are typically installed between the CGA connection and the pigtail on the cylinder end. Additional applications could include installation on the regulator inlet or outlet.

PART NO.	MATERIAL	DESCRIPTION
4300428	Chrome Plated Brass	LH Block & Bleed
4300429	Chrome Plated Brass	RH Block & Bleed

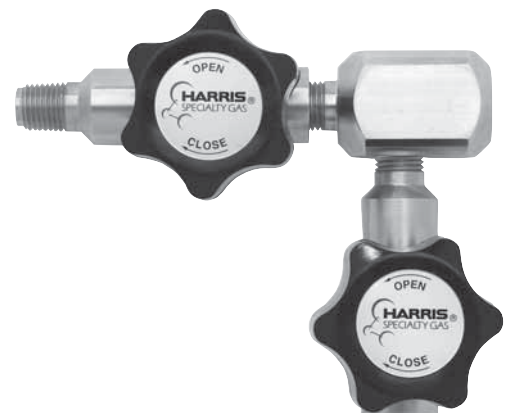

P/N: 4300428

# ACCESSORIES

## Diaphragm Valves



### DIAPHRAGM VALVES

Diaphragm (packless) valves are used in high purity gas systems where leakage and in-board diffusion of air or moisture must be kept to a minimum. The gas being handled is completely sealed off from the outside environment by a series of 316SS diaphragms. There is no stem in the gas stream thus eliminating stem leakage common in other valve designs.

Harris diaphragm valves are totally free of springs, bellows, packing, o-rings and lubricants in the process wetted area making them ideal for high purity gases. Metal-to-metal seals insure that there is no outgassing of undesirable elements into the flow stream. Polished 316L stainless steel diaphragms maintain the utmost in chemical resistance and life span.

The Harris valve is constructed from the highest quality materials to insure years of unsurpassed performance. Modern design concepts are combined with state of the art manufacturing technology. The Harris diaphragm valve is available as a regulator outlet shut off valve as a means to isolate the regulator from the downstream equipment or as a process isolation valve to be used in purges, gas control panels or other gas control systems. The Harris diaphragm valve is available as a multi-turn valve or 1/4 turn instrument shut off valve. 1/4 turn valves have the advantage of a visual indication of valve position resulting in greater safety, less operator error and potential saving in gas usage. Each version is supplied in brass, chrome plated brass or stainless steel construction to meet the specific application. These diaphragm valves have an in-board helium leakage rate of  $2.0 \times 10^{-8}$  cc/sec.

### TYPICAL PANEL WITH DIAPHRAGM VALVES

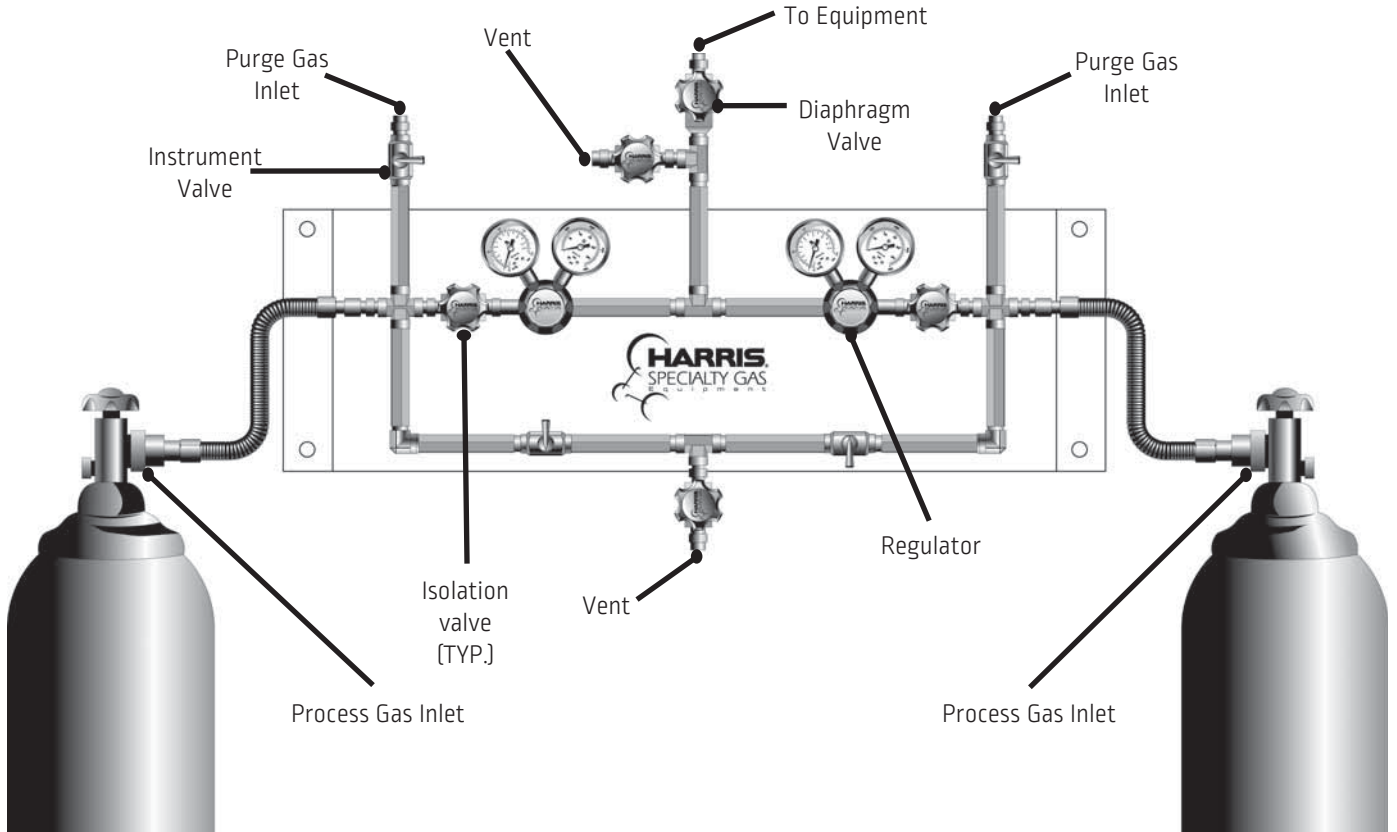

# ACCESSORIES

## Diaphragm Valves



1/2 Turn Instrument Valve

P/N: 9105190



1/4 Turn Regulator Valve

P/N: 9101386



Regulator Valve

P/N: 9101383



1/4 Turn Instrument Valve

P/N: 9101389

## REGULATOR OUTLET VALVE

Max. Inlet Pressure: 4500 PSIG, Flow Coefficient (CV): 0.13

PART NO.	DESCRIPTION	INLET/OUTLET CONNECTION	BODY MATERIAL	DIAPHRAGM MATERIAL	SEAT MATERIAL
9101382	Regulator Outlet Valve	1/4 NPT Female / 1/4 NPT female	Brass	316 SS	PCTFE (Kel-F™)
9101383	Regulator Outlet Valve	1/4 NPT Female / 1/4 NPT female	Nickel Plated Brass	316 SS	PCTFE (Kel-F™)
9101384	Regulator Outlet Valve	1/4 NPT Female / 1/4 NPT female	316 SS	316 SS	PCTFE (Kel-F™)

## 1/2 TURN INSTRUMENT VALVE

Max. Inlet Pressure: 4500 PSIG, Flow Coefficient (CV): 0.13

PART NO.	DESCRIPTION	INLET/OUTLET CONNECTION	BODY MATERIAL	DIAPHRAGM MATERIAL	SEAT MATERIAL
9105189	1/2 Turn Instrument Valve	1/4 NPT male / 1/4 NPT female	Brass	316 SS	PCTFE (Kel-F™)
9105190	1/2 Turn Instrument Valve	1/4 NPT male / 1/4 NPT female	Nickel Plated Brass	316 SS	PCTFE (Kel-F™)
9105191	1/2 Turn Instrument Valve	1/4 NPT male / 1/4 NPT female	316 SS	316 SS	PCTFE (Kel-F™)

## 1/4 TURN VALVE

Max. Inlet Pressure: 4500 PSIG, Flow Coefficient (CV): 0.13

PART NO.	INLET/OUTLET DESCRIPTION	BODY CONNECTION	DIAPHRAGM MATERIAL	SEAT MATERIAL	MATERIAL
9101388	1/4 Turn Instrument Valve	1/4 NPT female / 1/4 NPT female	Brass	316 SS	PCTFE (Kel-F™)
9101390	1/4 Turn Instrument Valve	1/4 NPT female / 1/4 NPT female	316 SS	316 SS	PCTFE (Kel-F™)
9101389	1/4 Turn Instrument Valve	1/4 NPT female / 1/4 NPT female	Nickel Plated Brass	316 SS	PCTFE (Kel-F™)
9101385	1/4 Turn Regulator Valve	1/4 NPT male / 1/4 NPT female	Brass	316 SS	PCTFE (Kel-F™)
9101387	1/4 Turn Regulator Valve	1/4 NPT male / 1/4 NPT female	316 SS	316 SS	PCTFE (Kel-F™)
9101386	1/4 Turn Regulator Valve	1/4 NPT male / 1/4 NPT female	Nickel Plated Brass	316 SS	PCTFE (Kel-F™)



# ACCESSORIES

Needle Valves, Relief Valves and Annunciator



P/N: 9100827



## NEEDLE VALVES

These valves are used where a shut off feature or some degree of throttling is required.

### SPECIFICATIONS

Inlet: .....1/4" MNPT  
 Max. Inlet Pressure: .....3000 PSIG  
 Seat Material: .....316 SS  
 Packing Material: .....PTFE

PART NO.	BODY MATERIAL	OUTLET	CV.
9100412	Brass	1/4" MNPT	.37
9100415	Brass	1/8" MNPT	.37
9100827	Chrome Plated Brass	1/4" MNPT	.37
9100927	Chrome Plated Brass	1/4" FNPT	.37

## ADJUSTABLE RELIEF VALVES

These relief valves may be used as an integral part of a pressure regulator or on equipment downstream of a regulator. The relief valves have a 1/4" MNPT inlet and outlet thread to vent gases either externally or remotely. Cv= .37

STAINLESS STEEL			BRASS			CHROME-PLATED BRASS		
PART NO.	MODEL NO.	PSIG	PART NO.	MODEL NO.	PSIG	PART NO.	MODEL NO.	PSIG
9100856	RV-7050-SS	0-50	9100852	RV-7050-B	0-50	9100861	RV-7050-CHR	0-50
9100857	RV-7100-SS	0-100	9100853	RV-7100-B	0-100	9100863	RV-7100-CHR	0-100
9100858	RV-7250-SS	0-250	9100854	RV-7250-B	0-250	9100864	RV-7250-CHR	0-250
9100859	RV-7500-SS	0-500	9100855	RV-7500-B	0-500	9100865	RV-7500-CHR	0-500
9100877	RV-7800-SS	0-800	9100876	RV-7800-B	0-800	9100878	RV-7800-CHR	0-800

## ANNUNCIATOR

The Harris Model 1031 two-channel remote alarm panel offers two input and two output channels, along with dry contact relay outputs and normally open output capabilities. Other features include a highly visible lighted status notification, a distinctive audible notification, auto-reset when cylinders are replenished, an audible alarm silence feature, the ability to "Daisy Chain" multiple alarm panels together, and Class I, Division II status with a NEMA 4 rating.

- 2" Gauge (0-400 psi or 0-3000 psi)
- Chrome Plated or Stainless Steel available
- Switch can be manually adjusted to any pressure on the gauge dial
- Requires 115VAC



PART NO.	DESCRIPTION	EXTENSION CABLE
9030318	Two-Channel Alarm Annunciator Box, only	-
4300823	Two-Channel Alarm Panel w/single gauge 3,000 psig for reg., chrome	25'
4300824	Two-Channel Alarm Panel w/ single gauge SS. 3,000 psig for reg., stainless steel	25'
4300825	Two-Channel Alarm Panel w/2 gauges for 900 and 905 series, chrome	25'
4300826	Two-Channel Alarm Panel w/2 gauges for 900 and 905 series, stainless steel	25'
4300827	Two-Channel Alarm Panel w/2 gauges for gas phase Dewar service, chrome	25'
4300828	Two-Channel Alarm Panel w/2 gauges for gas phase Dewar service, stainless steel	25'



# ACCESSORIES

Outlet fittings, flashback arrestors, checkvalves



## OUTLET FITTINGS

PART NO.	TYPE	DESCRIPTION	MATERIAL
9000200		1/4" MNPT x 1/4" MNPT	Brass
9009247		1/4" NPT x 1/4" NPT	Chrome Plated
9007056	Male Hex Coupling	1/4" MNPT x 1/4" MNPT	316 Stainless Steel
9005724		1/4" NPT x 4"	316 Stainless Steel
9007383		1/4" NPT x 4"	316 Stainless Steel
9005707		1/2" NPT x 2"	Brass
9005704		1/2" MNPT x 4"	Brass
9005740	Adaptors	1/4" MNPT x 1/2" FNPT	Brass
9005752		1/2" MNPT x 1/4" FNPT	Stainless Steel
9005753		1/2" MNPT x 1/4" MNPT	Stainless Steel
9007049	Tube Fittings	1/4" x 1/4" MNPT	Stainless Steel
9007051		1/4" x 1/4" MNPT	Brass
9007050		1/8" x 1/4" MNPT	Stainless Steel
9007052		1/8" x 1/4" MNPT	Brass
9007055	Hose Barbs	1/4" x 1/4" MNPT	Brass
9007053		1/8" x 1/8" MNPT	Brass
9007054		1/8" x 1/4" MNPT	Brass
9510501		1/4" x 1/4" FNPT	Brass
9005386	Bushing	1/4" MNPT x 1/2" MNPT	Brass
9005806		1/4" FNPT x 1/2" MNPT	Brass



Male Hex Coupling



Adaptor

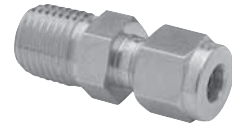

Tube Fitting



Hose Barb

## FLASHBACK ARRESTORS

Stainless steel flashback arrestors are designed for oxygen, hydrogen and other flammable or fuel gases. Standard with 1/4" FNPT inlet and 1/4" MNPT outlet connections make it easy to adapt in various applications. UL listed. Red fuel and green oxygen labels are included.

PART NO.	DESCRIPTION	WORKING PRESSURE	ELASTOMERS
4300146	Hydrogen	50 PSIG	
	LPG/Methane	50 PSIG	Viton
	Acetylene	15 PSIG	
	Oxygen	143 PSIG	Viton



## CHECK VALVES

Check valves insure unidirectional flow of compressed gases. They provide a simple, effective way to prevent backflow in gas delivery systems. Check valves are available in brass or 316 stainless steel.

### SPECIFICATIONS

Cracking pressure: 1 psi

C<sub>v</sub>: 0.15

Operating temperature range: -20F to +14F

PART NO.	INLET	OUTLET	MATERIAL	SEAT	MAX WORKING PRESSURE
4300379	1/4" FNPT	1/4" FNPT	Brass	Viton	3000 PSIG
4300380	1/4" FNPT	1/4" FNPT	316SS	Viton	3000 PSIG
4300386	1/4" FNPT	1/4" FNPT	316SS	EPR	3000 PSIG
4300421	1/4" MNPT	1/4" FNPT	316SS	EPR	6000 PSIG



# ACCESSORIES



## MODEL 8010 - HIGH PRESSURE PURIFIER

The model 8010 gas purifier protects your gas system from contamination of oil and water found in some industrial gases and occasionally even in specialty carrier gases. The small daily operating costs are more than justified by the prevention of a system shut-down and the subsequent cleaning and/or repair costs.

The model 8010 purifier shell must be used with a specially designed replaceable cartridge. These cartridges are shipped in hermetically sealed cans with convenient pull-tab tops for easy opening. This improved packaging ensures full retention of capacity in storage until the time of use.



### Materials of Construction

Shell body: Aluminum anodized blue  
 Shell Head: Chrome plated brass  
 Seal: Buna N

### Specifications:

Maximum operating pressure: 2000 PSIG (500 PSIG for oxygen)  
 Operating temperature range: 40° F to 165° F (40° C to 75° C)  
 Dew point achievable: 100° F (75° C)  
 Inlet and outlet ports: 1/4" FNPT  
 Dimensions: 2" dia x 5 3/4" long  
 Weight with cartridge: 1.5 Lbs.

PART NO.	MODEL	DESCRIPTION
4302792	Purifier	8010
4302793	Cartridge	8010 13X Oil & Water
4302794	Cartridge	8010 4A Water
4302795	Cartridge	8010 Activated Charcoal THC

## Gas Purifier Model 8010 Layout

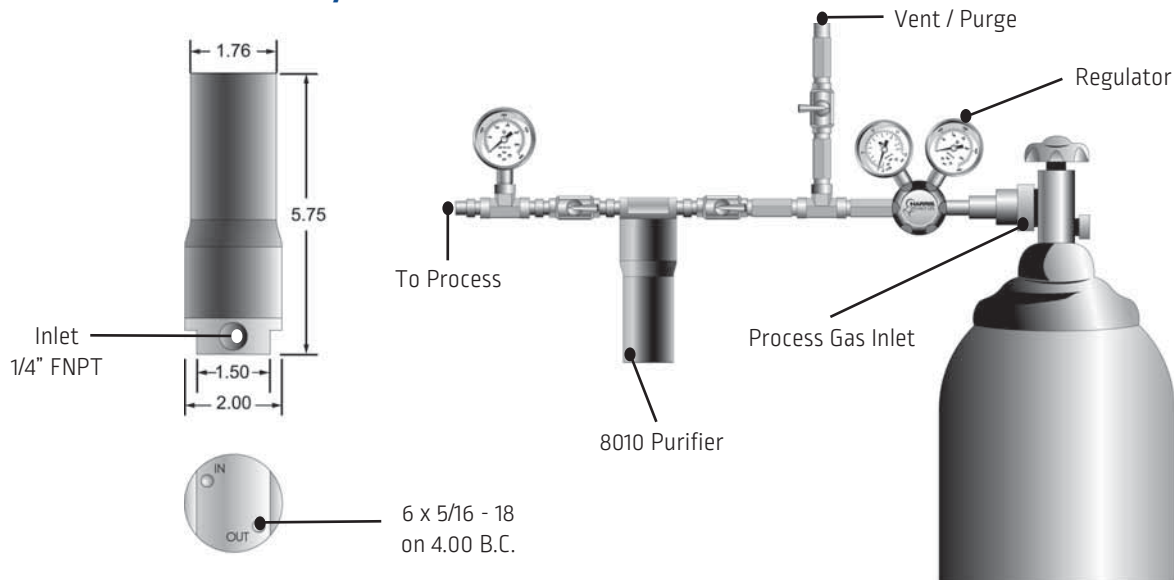

# ACCESSORIES

## Tee-Type & In-Line Filters



### TEE-TYPE FILTERS

- Stainless Steel Body
- Filter element can be replaced without removing body from system
- Replaceable sintered elements are available in 0.5, 2 micron pore sizes
- End connections are 1/4" x 1/4" FNPT

PART NO.	MODEL	DESCRIPTION
4300406	4 FT 0.5	Tee Type Filter 0.5 Micron
4300407	4 FT 2.0	Tee Type Filter 2 Micron

### IN-LINE FILTERS

- Stainless Steel Body
- Replaceable sintered elements are available in 0.5, 2 micron pore sizes
- End connections are 1/4" x 1/4" FNPT

PART NO.	MODEL	DESCRIPTION
4300404	4F 0.5	In-Line Filter 0.5 Micron
4300405	4F 2.0	In-Line Filter 2 Micron

### REPLACEMENT FILTER ELEMENTS FOR TEE-TYPE & IN-LINE

PART NO.	MODEL	DESCRIPTION
4300408	K4-0.5	Replacement Element 0.5 Micron
4300409	K4-2.0	Replacement Element 2 Micron

### TEE-TYPE FLOW DIAGRAM

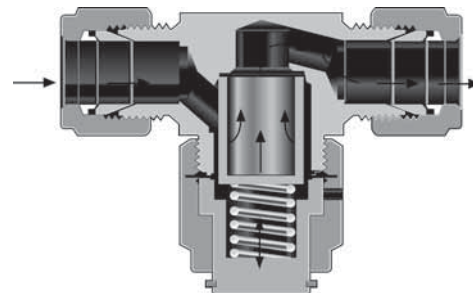

### IN-LINE FILTER FLOW DIAGRAM

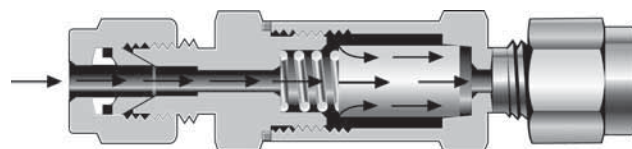

### Micron Filter Flow

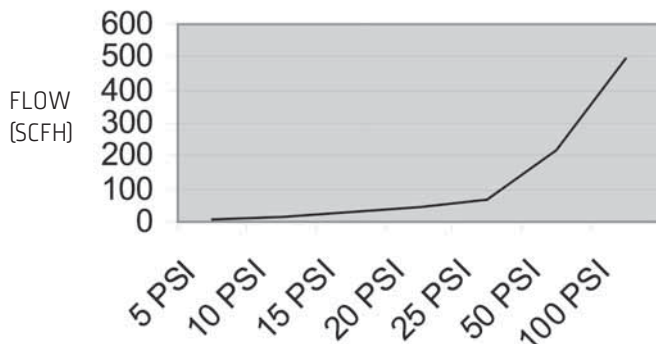



# ACCESSORIES

## Pressure Gauges

Two-inch pressure gauges are available in brass, chrome-plated brass and 316 stainless steel. All gauges have a bottom mount 1/4 NPT male connection. All gauges have an accuracy of  $\pm 3-2-3\%$  of full scale.

### CHROME-PLATED BRASS GAUGES

PART NO.	RANGE	INCREMENTS
9006270	*30" Hg-0-30psi/2bar	1 PSIG
9006271	*30" Hg-0-100psi/7bar	2 PSIG
9006272	*30" Hg-0-200psi/14bar	5 PSIG
9006273	400psi/28bar	10 PSIG
9006274	1000psi/70bar	20 PSIG
9006275	4000psi/280bar	100 PSIG

\* Compound gauge 30" Hg VAC to psi/bar



### 316 STAINLESS STEEL GAUGES

PART NO.	RANGE	INCREMENTS
9006282	*30" Hg-0-30psi/2bar	1 PSIG
9006283	*30" Hg-0-100psi/7bar	2 PSIG
9006284	*30" Hg-0-200psi/14bar	5 PSIG
9006285	400psi/28bar	10 PSIG
9006286	1000psi/70bar	20 PSIG
9006287	4000psi/280bar	100 PSIG

\* Compound gauge 30" Hg VAC to psi/bar

### BRASS GAUGES

PART NO.	RANGE	INCREMENTS
9006276	*30" Hg-0-30psi/2bar	1 PSIG
9006277	*30" Hg-0-100psi/7bar	2 PSIG
9006278	*30" Hg-0-200psi/14bar	5 PSIG
9006279	400psi/28bar	10 PSIG
9006280	1000psi/70bar	20 PSIG
9006281	4000psi/280bar	100 PSIG

\* Compound gauge 30" Hg VAC to psi/bar

### CYLINDER INLET CONNECTIONS STEMS: 1/4" MNPT X CGA

CGA	BRASS			CHROME PLATED BRASS		STAINLESS STEEL		
	Nut	Stem	Stem / CV	Nut	Stem	Nut	Stem	Gasket
240	-	-	-	-	-	-	9100752	-
300	9002984	9005168	9005732	9003017	9005184	-	-	-
300P	9002989	9005168	9005732	-	-	-	-	-
320	9002986	9005114	9005746	9002987	9005365	9003062	9005188	9002908
326	9002966	9005170	9005733	9002967	9005364	9003063	9005189	-
330	-	-	-	-	-	9003019	9005185	9003097
346	9002969	9000319	9005734	9002970	9005181	9003064	9005190	-
350	9003006	9005145	9005735	9003012	9005179	9003033	9005191	-
510	9002972	9005109	9005736	9002973	9005174	9003035	9005194	-
510P	9002974	9005109	-	9000429	9005174	--	-	-
540	9002950	9005110	9005737	9002952	9005363	9003067	9005193	-
580	9003048	9005109	9005736	9003050	9005174	9003036	9005194	-
590	9003052	9005109	9005736	9003061	9005174	9003037	9005194	-
660	9003089	9005207	-	-	-	9003023	9005186	9003098
705	-	-	-	-	-	9003024	9005187	9003099



# PIGTAILS



Pigtails are flexible hose designed for gas systems at pressures up to 3000 psig. Harris offers pigtails with a variety of end fittings including common CGA connections with integral non-return check valves. Armor cased pigtails come with an outer armor casing to prevent kinking and whipping in the event of an internal failure.

Harris offers these pigtails in various different lengths, in either all stainless steel construction or stainless steel lined with PTFE.

## FEATURES

- Brass and Stainless Steel Fittings
- Available in different materials of construction for various gases
- Intergrated check vales to prevent reverse flow of gases.  
Limited to CGA
- Helium and Hydrogen Diffusion resisitant stainless steel models
- Cleaned for oxygen service

## PIGTAIL CROSS SECTIONAL VIEW

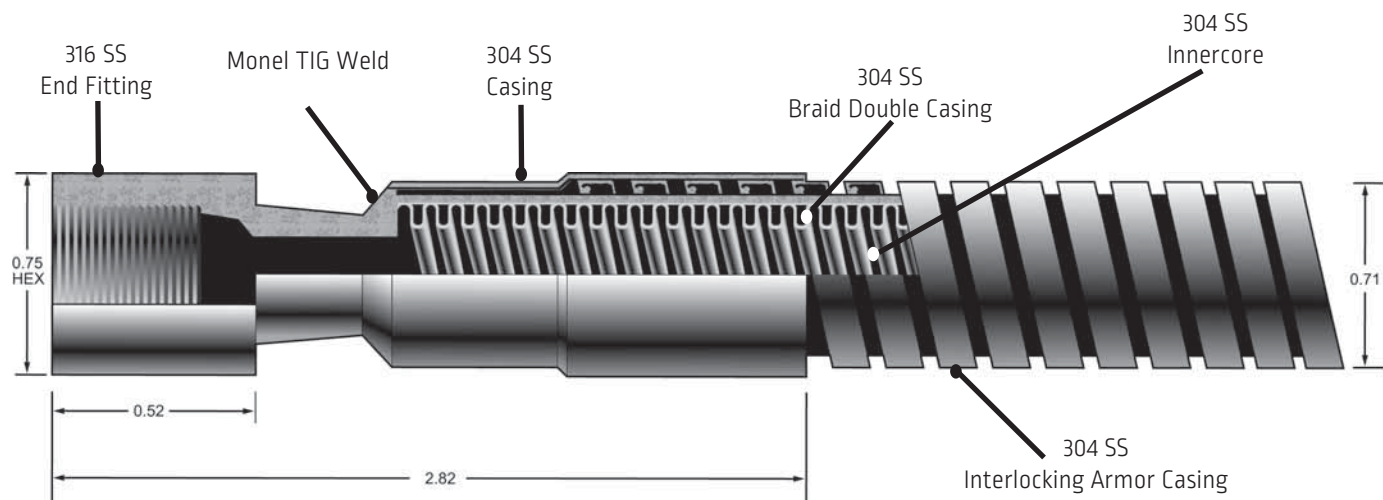

Note: CGA 346 is Harris' common manifold header connection. These pigtails should be purchased as replacement items for Harris manifold systems.





## PIGTAIL ORDERING INFORMATION

PT	120	D	B	320	4MN - 1/4" NPT Male	
SERIES	LENGTH (INCHES)	PIGTAIL TYPE (BOTH ENDS)	CONNECTION MATERIAL	INLET CONNECTION	OUTLET CONNECTION	PRESSURE RATING
PT	24	D - Tefzel Line / Brass Ends	B - Brass	4FN - 1/4" NPT Female	4FN - 1/4" NPT Female	Blank -3k psig
	36	A - Armor Case / Stainless Steel Line	S- Stainless Steel	4MN - 1/4" NPT Male	4MN - 1/4" NPT Male	6 - 6k psig
	48	/ Stainless Steel Ends		4TB - 1/4" Tube Fitting Brass	4TB - 1/4" Tube Fitting Brass	
	72			6TB - 3/8" Tube Fitting Brass	6TB - 3/8" Tube Fitting Brass	
	120			4TS - 1/4" Tubing Fitting Stainless Steel	4TS - 1/4" Tubing Fitting SS	
				4FV - 1/4" VCR Female Stainless Steel	4FV - 1/4" VCR Female SS	
				240 - CGA 240 - Ammonia	346 - CGA 346-Medical Air	
				280 - CGA 280-Medical O2 Mixtures	580 - CGA 580-N2-He-Ar	
				296 - CGA 296-Ind'l Oxidizing Mix		
				300 - CGA 300 - Acetylene		
				320 - CGA 320-Carbon Dioxide		
				320HT - CGA 320-Carbon Dioxide Hand Tight		
				326 - CGA 326-Nitrous Oxide		
				330 - CGA 330-HCL, H2S & corrosives		
				346 - CGA 346-Medical Air		
				346HT - CGA 346-Medical Air Hand Tight		
				350 - CGA 350-Methane-H2-Ethylene		
				500 - CGA 500-Medical Mixtures		
				510 - CGA 510 (Not for Acetylene) A 296-Ind'l Oxidizing Mix		
				510A - CGA 510A-Acetylene		
				510P - CGA 510P-Propane & LP Gases		
				540 - CGA 540-Oxygen		
				540HT - CGA-540-Oxygen Hand Tight		
				580 - CGA 580-N2-He-Ar		
				580HT - CGA 580-N2-He-Ar Hand Tight		
				590 - CGA 590-Industrial Air-SF6		
				660 - CGA 660-Corrosives Gases		
				705 - CGA 705-Anhydrous Ammonia		

# ACCESSORIES

## Cylinder Wall & Bench Brackets

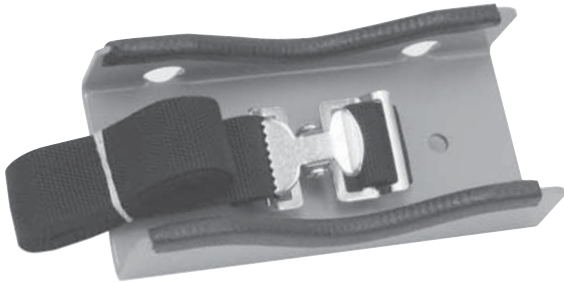

### G 100 SINGLE CYLINDER WALL BRACKET

The G 100 is an all steel construction bracket with many quality construction features. The edges are protected with steel reinforced vinyl edge guarding to maintain and protect your cylinders and provide extra grip. Steel parts are sealed with epoxy powder paint to assure long service life and chemical resistance. Straps and cinch style buckles are chosen as primary means of support as they enable the cylinders to be held tight and secure against the brackets. Support straps are 1 1/2" wide by 54" long polypropylene with steel cinch buckle and rate a robust 1200 PSIG strength. Supports hold cylinders from 4" to 12" diameter.

Part No.	Description	Size	Weight
4302650	G 100	4.25"x 8"x 2.25"	3 lb.
4302652	Optional Chain Set	41"	1 lb.

\*P/N: 4302651 Replacement Strap, 1 1/2" x 54" 1 lb.



### G 110 SINGLE CYLINDER ADJUSTABLE WALL BRACKET

Molded from reinforced polypropylene, the G 110 bracket can be adjusted to snugly support any cylinder from 4" to 14" diameter. Unit is first set to designated cylinder diameter with recessed set screws locking in width position. Permanently mounts to wall using fasteners (not included). Strap and security chain sets included.

Part No.	Size	Weight
4302653	9"x 4"x 5"	2 lb.

\*P/N: 4302651 Replacement Strap, 1 1/2" x 54" 1 lb.

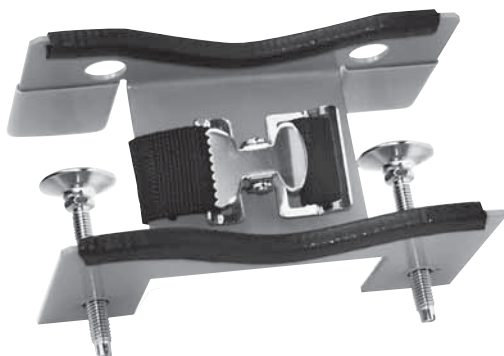

### G 150 SINGLE CYLINDER BENCH MOUNT BRACKET

Bench cylinder bracket G-150: This bench mount single cylinder bracket uses dual mounting posts with swivel feet and non-slip pads to clamp to bench or table tops from 3/8" to 1 3/4" thick. Standard strap set and optional chain set (G-105) secure cylinders 4" to 14" diameter. Especially useful where walls are not accessible to attach brackets or when temporary, safe cylinder supports are required.

Part No.	Description	Size	Weight
4302654	G 150	4.25"x 8"x 4.25"	4.5 lb.
4302652	Optional Chain Set	41"	1lb.

\*P/N: 4302651 Replacement Strap, 1 1/2" x 54" 1 lb.

# ACCESSORIES

Cylinder Brackets & Floor Stands



## G 181 SINGLE CYLINDER FLOOR STAND

The G-181, safely supports 4" through 10" diameter cylinders using a combination of cinch buckle, polypropylene strap, and 10 gauge steel bar. Designed and built for the safe storage of industrial and commercial use gas cylinders, this stationary rack is constructed from cold rolled steel. One cylinder capacity stands share the 1 1/2" polypropylene straps and steel cinch buckles used in our brackets. All welded construction and quality epoxy powder paint finishes provide structural integrity and long service life. As with our cylinder brackets, surfaces coming into direct contact with the cylinders are protected with steel reinforced vinyl edge guards, protecting your equipment.

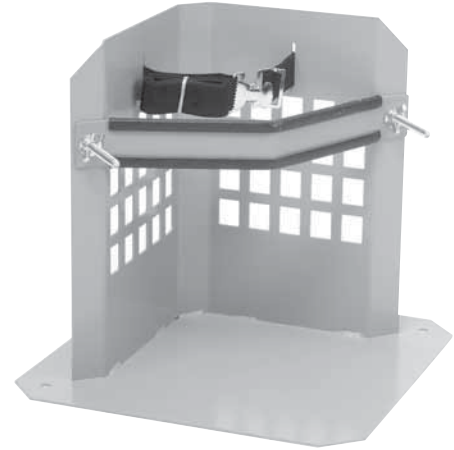

Part No.	Size	Weight
4302655	16" x 16" x 15"	21 lb.

## WALL MOUNTED CYLINDER BRACKETS

All steel construction brackets and racks share many quality construction features. 11 gauge hot rolled steel form the foundation. Edges are protected with steel reinforced vinyl edge guarding to help maintain your cylinders and provide extra grip. Steel parts are sealed with epoxy powder paint to assure long service life and chemical resistance. Straps and cinch style buckles are chosen as primary means of support as they enable the cylinders to be held tight and secure against the brackets. Support straps are 1 1/2" wide by 54" long polypropylene with steel cinch buckle and rate a robust 1200 PSIG strength. Supports hold cylinders from 4" to 12" diameter.

Part No.	Model No.	Size	Weight
4302656	G200	24"x2"x4"	8 lb.
4302659	G300	4.25"x36"x2.25"	11 lb.
4302662	G401	4.25"x48"x2.25"	14 lb.

\*P/N: 4302651 Replacement Strap, 1 1/2" x 54" 1 lb.



G 200 Double Cylinder Wall Bracket



G 300 Triple Cylinder Wall Bracket



G 401 Four Cylinder Wall Bracket



# ACCESSORIES

## Cylinder Racks & Process Stations



G 400 Four Cylinder Floor Stand

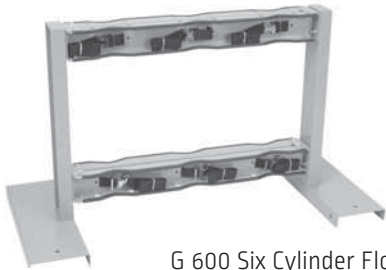

G 600 Six Cylinder Floor Stand

### CYLINDER RACKS & PROCESS STATIONS

The stationary cylinder floor stands and process stations are designed and built for the safe storage of industrial and commercial use gas cylinders up to a 12" diameter. These stationary racks are constructed from 11 gauge and heavier plate steel. The cylinder capacity racks share the 1.5" polypropylene straps and steel cinch buckles used in our brackets. Fully welded construction and quality epoxy powder paint finishes provide structural integrity and long service life. As with our cylinder brackets, surfaces coming into direct contact with the cylinders are protected with steel reinforced vinyl edge guards, protecting your equipment. Units ship partially disassembled for freight savings.

Part No.	Model No.	Size	Weight
4302661	G400	24"x32"x30"	65 lb.
4302665	G600	24"x48.5"x30"	81 lb.



G 277 Two Cylinder Process Station Rack



G 400P Four Cylinder Process Station



G 600P Six Cylinder Process Station

PART NO.	MODEL NO.	SIZE	WEIGHT
4302673	G277	12" x 28" x 72"	56 lb.
4302675	G400P	24" x 36.5" x 72"	98 lb.
4302676	G600P	24" x 48.5" x 72"	119 lb.

\*P/N: 4302651 Replacement Strap, 1 1/2" x 54" 1 lb.

# GAS CYLINDER JACKET

Cylinder Jackets



Optional Regulator Hood Shown  
PN: 9030160



When mixing several hydrocarbon components in a cylinder and exposing the cylinder to low temperatures the hydrocarbon will become a sticky mess. The heavier molecules will stick to the cylinder walls causing problems with the accuracy of the mixture. To prevent this from happening, Harris' cylinder jacket features a self-limiting heated cable that prevents overheating. This cable heats up to 120°F. It is designed to maintain the temperature of the hydrocarbon above its dew point, keeping the gas from stratifying. Harris' cylinder jacket is constructed of materials approved by UL® for Class 1 Division 2, Group B, C, and D hazardous locations.

## FEATURES

- Prevents hydrocarbons mixtures from stratifying and insulates to prevent the content from condensing
- Silicone-impregnated fiberglass liner and polyester exterior provides protection from the elements
- Fluoropolymer over jacket protects the heat cable from corrosion
- D-rings with Velcro® line provides a snug closure to keep the heat in
- Applications natural gas, power plants and utilities

## SPECIFICATIONS

Maintain Temperature:  
@ 70°F Ambient: 120°F  
@ 0°F Ambient: 60°F

Electrical Classifications:  
Class 1 Division 2 Groups B, C, and D

Power Output:  
8 watts/ft at 50°F

Power Requirements:  
120 Voltage (240 Voltage option)

Flexible Conduit:  
10' of 3 color coded conductors

## MATERIALS

Insulation	Closed cell foam
Lining	Silicone impregnated fiberglass
Exterior	Polyester

## RELATED OPTIONS

P/N: 9030160 Regulator Hood Blanket

## ORDERING INFORMATION

PART NO.	CYLINDER SIZE	DIMENSIONS	ELECTRICAL
9030154	150A,AL,1R	11" x 48"	12' of internal wire
9030148	350, XL, 1F	17" X 45"	19' OF INTERNAL WIRE
9030157	LP5	14" X 18"	5' of internal wire

Other sizes available - call customer service @1.800.733.4043 option 2

NOTE: These jackets are not designed to heat up cylinders that have been in cold or freezing environments. Cold cylinders need to be brought up to temperature before using the blanket.

Excess heat lost can be experience through the top of the cylinder jacket. Harris recommends the regulator hood blanket to prevent this heat lost.



THE HARRIS PRODUCTS GROUP  
www.harrisproductsgroup.com

Orders: 1.800.733.4043

# GAS CYLINDER CABINETS



Gas cylinder cabinets are designed to provide a safe and effective means to isolate hazardous or flammable gas cylinders, when connected to a properly designed ventilation system, to exhaust hazardous or flammable gases to a remote location in order to protect personnel from exposure. The use of gas cabinets provides a convenient way to achieve separation of gases by their classifications to satisfy both national and local fire and building codes. The cylinder gas cabinets can safely store 1-4 standard size gas cylinders, are constructed of 11 gauge steel to exceed code requirements.

These cabinets can be fitted with manifolds, or the Harris EZ regulator mounting or other gas controls so that both the cylinder and the control system are enclosed. The cabinet has the capacity to allow 150–200 linear feet per minute of air to pass across the open window face to ensure that workers are not exposed.

## FEATURES

- All-welded construction using 11-gauge steel (exceed code requirements) provides for extra structural strength.
- Epoxy painted texture finish on outside and smooth finish on inside enhances cabinet appearance.
- Louvered panel on base of door provides maximum coverage of air flow through cabinet.
- Removable back panel on inside rear of cabinet can be used to mount gas delivery systems used to mount gas delivery systems.
- Adjustable cylinder bracket(s) with chain(s) accommodate a large range of cylinder sizes and secures cylinders.
- Door and access window close and latch automatically preventing them from being accidentally left open.

## SPECIFICATIONS

Compliances: .....Uniform Fire Code, Uniform Building Code, Federal OSHA, Cal OSHA, NFPA, SEMI Standards

Integral Sprinkler: .....160–165°F Activation, Coated with Bee's Wax for Protection from Corrosive Environments

Window: ..... 1/4" thick wire reinforced safety glass

Finish: .....Epoxy Coating

Color: .....Blue (other colors are available)

Floor: .....Diamond deck

Body of cabinet: ..... 11-Gauge Steel

Fasteners: .....Stainless Steel



# GAS CYLINDER CABINETS



Optional manifold sold separately



Large vent exhaust (6" diameter x 3" high)



Integral sprinkler that is activated in the event of fire



Louvered door panel to provide positive air flow



Adjustable cylinder brackets secure a wide range of cylinders



Removable back panel enables the mounting of gas delivery systems and components



Large shatter proof windows permit visual inspection and access into cabinet for adjustments while minimizing operator exposure to potential toxic leaks

**Contact Harris Specialty Gas for quotes on custom gas cabinets.**  
**1.800.733.4043**

## ORDERING INFORMATION

PART NO.	# OF CYLINDERS	DIMENSIONS	WEIGHT
9030387	CABINET,7000 1CYL BLUE	18" W x 18" D x 72" H	235 lbs
9030388	CABINET,7000 2CYL BLUE	24" W x 18" D x 72" H	283 lbs.
9030389	CABINET,7000 3CYL BLUE	36" W x 18" D x 72" H	331 lbs.
9030390	CABINET,7000 4CYL BLUE	48" W x 18" D x 72" H	391 lbs.
9030391	CABINET,7000 1CYL OUTDOOR BLUE	-	-
9030392	CABINET,7000 2CYL OUTDOOR BLUE	-	-
9030393	CABINET,7000 3CYL OUTDOOR BLUE	-	-
9030394	CABINET,7000 4CYL OUTDOOR BLUE	-	-
9030395	LOCK,CABINET DOOR	-	-
9030396	CAP,CABINET RAIN VENT	-	-



THE HARRIS PRODUCTS GROUP  
www.harrisproductsgroup.com

Orders: 1.800.733.4043

# A QUALITY LINE OF MEDICAL REGULATORS AND ACCESSORIES.

Health care professionals around the world count on Harris medical equipment for exceptional reliability and value. From hospitals to home health care, Harris has the right regulation equipment for the job.



# MODEL 301/1501



Small Metering Regulators



The Harris Model 301 regulators are compact single-stage metering regulators ideally suited for oxygen therapy applications using small cylinders or where space and weight limitations are important.

The design of this regulator has made it a popular choice for home care, ambulance, hospital transport or doctor/dentist offices.

## FEATURES

- Sintered bronze filters in the inlet port and outlet fitting.
- Captive adjusting knob.
- Internal relief system to guard against over-pressurization.

## MODEL 301 ORDERING INFORMATION

GAS	PART NO.	MODEL NO.	FLOW RANGE	INLET	GAUGE SIZE
Oxygen	3500603*	301-OX15M-870	0-15 LPM	CGA-870 (yoke)	2
Oxygen	3500619*	301-OX15L-540	0-15 LPM	CGA-540	2"
Oxygen	3500607	301-OX 8M-870	0-8 LPM	CGA-870 (yoke)	2"
Oxygen	3500613	301-OX 5L-540	0-5 LPM	CGA-540	2"
Oxygen	3500612	301-OX 5M-870	0-5 LPM	CGA-870 (yoke)	2"
Nitrous Oxide	3500604	301-N2O-15M-910	0-15 LPM	CGA-910 (yoke)	2"

**\*SHIPS IN 24 TO 48 HOURS**

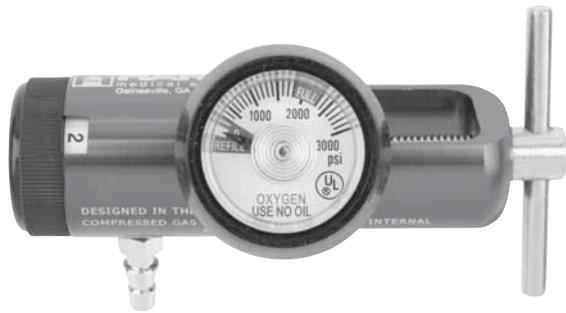

The Model 1501 is an oxygen regulator designed for home healthcare, hospital and pediatric applications.

## FEATURES

- Lightweight aluminum body with brass internal components.
- Precise dial-in flow control.
- Permanent laser etched markings.
- Sintered inlet filter for safety and regulator life.
- Barb or DISS outlet available.
- 1.4" diameter gauge with protective boot.
- Conforms to CGA E-8 and ASTM G175.

## MODEL 1501 ORDERING INFORMATION

PART NO.	MODEL NO.	FLOW RANGE	OUTLET
3500397	1501-15-870	0-15 LPM	BARB
3500399	1501-15-540	0-15 LPM	DISS

**SHIPS IN 24 TO 48 HOURS**

0-8 LPM Ranges- .5, 1, 1.5, 2, 2.5, 3, 4, 5, 6, 8  
 0-15 LPM Ranges- .5, 1, 1.5, 2, 3, 4, 6, 8, 10, 15



# MODEL 301

Small Preset and Metering Regulator



The Model 301 single stage preset oxygen regulator possesses the sensitivity and flow control of much larger regulators in a compact design.

Preset at 50 PSIG, the Model 301 is designed to provide equipment downstream with constant pressure.

## FEATURES

- Internal safety disc to guard against over-pressurization
- Sintered bronze filter
- 1/2" gauge engineered to ANSI B-40.1 specifications.

## ORDERING INFORMATION

GAS	PART NO.	MODEL NO.	INLET	GAUGE SIZE
Oxygen	3500617	301-50 PR-540	CGA-540	2"
Oxygen	3500616	301-50 PR-870	CGA-870 (yoke)	2"

## SHIPS IN 24 TO 48 HOURS



## MODEL 301 WITH CENTER BACK MOUNT

The Harris Model 301 single-stage metering regulator with centerback connection is a compact regulator with gauges positioned for fast, easy reference.

The Model 301 is commonly used in home care, ambulance, hospital transport or doctor/dentist office applications.

## FEATURES

- Flow gauges precision engineered to ANSI B-40.1 specifications.
- Captive adjusting knob.
- Internal relief system that protects against over-pressurization and a CGA-870 connection.

## ORDERING INFORMATION

GAS	PART NO.	MODEL NO.	FLOW RANGE	INLET	GAUGE SIZE
Oxygen	3500614	301-OX 15CB-870	15 LPM	CGA-870 (yoke)	1 1/2"





This single-stage preset regulator is recommended for applications using large cylinders, piping systems or other applications that require a constant pressure. The regulator is preset to deliver 50 PSIG.

### FEATURES

- Color coded 2" flow gauge engineered to ANSI
- B-40.1 specifications.
- Sintered bronze filters in the inlet port and outlet port.
- Large diaphragm for accurate delivery.
- Captive inlet nut to protect the seat.

### MODEL 25P ORDERING INFORMATION

**\* SHIPS IN 24 TO 48 HOURS**

GAS	PART NO.	MODEL NO.	INLET	OUTLET GAUGE SIZE
Oxygen	3500625*	25C-2T50P-540	DISS 1240	2"
Nitrous Oxide	3500626*	25C-2T50P-326	DISS 1040	2"
Carbon Dioxide	3500627	25C-2T50P-320	DISS 1080	2"
Air	3500628	25C-2T50P-346	DISS 1160	2"



The Model 25 is designed for extended trouble free service, features a large diaphragm that maintains an accurate flow rate from full cylinder to empty.

### FEATURES

- Captive inlet nut to protect the seat.
- Color coded pressure gauge engineered to ANSI B-40.1 specifications..

### ORDERING INFORMATION

GAS	PART NO.	MODEL NO.	DELIVERY RANGE	INLET	GAUGE SIZE
Oxygen	3500742	25-3 OX15M-870	0-15 LPM	CGA-870 (yoke)	2"
Oxygen	3500743	25-3 OX15M-540	0-15 LPM	CGA-540	2"
N2O	3500745	25-3C-100-326	0-100 PSI	CGA-326	2"
Oxygen	3500746	25-3C-100-540	0-100 PSI	CGA-540	2"
CO2/Oxygen (CO2 not over 7.5%)	3500744	25-3 OX15M-280	0-15 LPM	CGA-280	2"
N2O/Oxygen (N2O 47.5%-52.5%)	3500744	25-3 OX15M-280	0-15 LPM	CGA-280	2"

# CYLINDERS



Aluminum cylinders have an unmatched record for safety and performance. Harris medical cylinders provide unsurpassed service to medical gas users around the globe.

## FEATURES

- M6, M9, D and E sizes available (other sizes available upon request).
- 40% lighter than steel.
- Cleaned for oxygen service.
- Standard valve or toggle valve available.
- Safety paint and clearcoat to protect sidewall and provide heat detection.
- CGA 870 Inlet valve connection.

## MEDICAL GAS CYLINDERS - ALUMINUM

PART NUMBER	CYLINDER SIZE	OXYGEN CAPACITY	OUTSIDE DIA.	LENGTH*	VALVE TYPE
4309621	M6	5.8	3.21	11.5	Toggle
4309622	M6	5.8	3.21	11.5	Standard
4309623	M9	8.8	4.38	10.8	Toggle
4309624	M9	8.8	4.38	10.8	Standard
4309625	D	14.6	4.38	16.5	Toggle
4309626	D	14.6	4.38	16.5	Standard
4309627	E	24.1	4.38	25.6	Toggle
4309628	E	24.1	4.38	25.6	Standard

## COLOR-CODED MEDICAL GAUGES

Pressure gauges are available in chrome-plated brass. All gauges have an accuracy of  $\pm 3-2-3\%$  of full scale.

GAS	PART NO.	DESCRIPTION	COLOR	THREAD SIZE
Oxygen	9006032	2" 4000PSI 0/Full	Green	1/4 NPT
Nitrous Oxide	9006011	2" 1500 PSI	Blue	1/4 NPT
Carbon Dioxide	9006007	2" 1500 PSI	Gray	1/4 NPT
Air	9006033	2" 4000 PSI	Yellow	1/4 NPT
Oxygen	9006010	2" 15 LPM*	Green	1/4 NPT
Oxygen	9006027	2" 5 LPM*	Green	1/4 NPT
Oxygen	9006018	1-1/2" 8 LPM*	Green	1/8 NPT
Nitrous Oxide	9006017	1-1/2" 15 LPM*	Blue	1/8 NPT
Nitrous Oxide	9006043	1-1/2" 1500 PSI	Blue	1/8 NPT
Oxygen	9006029	1-1/2" 5 LPM*	Green	1/8 NPT
Oxygen	9001040	1-1/2" 15 LPM*	Green	1/8 NPT
Oxygen	9001038	1-1/2" 4000 PSI	Green	1/8 NPT Back Mount
Oxygen	9006028	2" 8 LPM*	Green	1/8 NPT
Oxygen	9000976	1-1/2" 3000 PSI	White	1/8 NPT Back Mount

Spiral Wound with Rubber Boot





# MEDICAL ACCESSORIES



## N2O YOKE

PART NO.	DESCRIPTION
9100003	Y-01 CGA-910



## OXYGEN YOKE

PART NO.	DESCRIPTION
9100018	Y-01 CGA-870



## CANNULA & SUPPLY TUBING

PART NO.	DESCRIPTION
4309620	Dual Lumen
4309633	Supply Tubing, 7ft.



## NUT/GLAND ASSEMBLY

PART NO.	DESCRIPTION
9100236	CGA DISS 1240



## YOKE SEALS

PART NO.	DESCRIPTION
9000169	Yoke Seals Package of (10)

## INLET STEMS



PART NO.	DESCRIPTION	GAS
9100706	F-25-280M CGA-280	O2/CO2-He/O2-N2/O2
9100707	F-25-320M CGA-320	CO2
9100166	F-25-540M CGA-540	O2
9100709	F-25-346M CGA-346	AIR

## REGULATOR OUTLETS



PART NO.	DESCRIPTION	GAS
9001116	CGA 1040 DISS	Nitrous Oxide
9001117	CGA 1160 DISS	Medical Air
9100164	CGA 1240 DISS 8 LPM (9/16-18 R.H.)	Oxygen
9000198	CGA 1240 DISS 15 LPM (9/16-18 R.H.)	Oxygen
9100280	CGA 1240 DISS (9/16-18 R.H.)	O2 Metering

## INLET CYLINDER NUTS



PART NO.	DESCRIPTION	GAS
9002965	6659-280M	O2/CO2-He/O2-N2/O2
9002952	6659-A-540M	O2
9002967	6659-326M	N2O
9002970	6659-346M	AIR
9004031	Nut Retaining Ring	



D and E Cylinder Wrench P/N: 9000754



# MATERIALS COMPATIBILITY



The compatibility data shown on the following pages has been compiled to assist in evaluating the appropriate materials to use in handling various gases. Prepared for use with the dry (anhydrous) gases at normal operating temperature of 70° (21° C), information may vary if different operating conditions exist.

## Directions:

Locate the gas you are using in the first column.

Compare the materials of construction for the equipment you intend to use with the materials of construction shown in the Compatibility Chart. Then use the Key to Materials Compatibility to determine the compatibility.

## COMPATIBILITY GUIDE

### COMMON NAME

### CHEMICAL FORMULA

		MATERIALS OF CONSTRUCTION										
		METALS					PLASTICS			ELASTOMERS		
		Brass	Stainless Steel	Aluminum	Zinc	Copper	PCTFE	Teflon®	Viton®	Buna-N	Neoprene	Polyurethane
Acetylene	C <sub>2</sub> H <sub>2</sub>	R1	•	I	U	U	•	•	R2	R2	R2	R2
Air	-	•	•	•	•	•	•	•	•	•	•	•
Allene	C <sub>3</sub> H <sub>4</sub>	•	•	•	I	U	•	•	•	•	•	I
Ammonia	NH <sub>3</sub>	U	•	•	U	U	•	•	U	•	•	U
Argon	Ar	•	•	•	•	•	•	•	•	•	•	•
Arsine	AsH <sub>3</sub>	•	•	R4	I	•	•	•	•	•	•	U
Boron Trichloride	BCl <sub>3</sub>	U	•	U	I	•	•	I	I	I	I	I
Boron Trifluoride	BF <sub>3</sub>	•	•	•	I	•	•	I	I	I	I	I
1,3-Butadiene	C <sub>4</sub> H <sub>6</sub>	•	•	•	•	•	•	•	U	•	•	U
Butane	C <sub>4</sub> H <sub>10</sub>	•	•	•	•	•	•	•	•	•	•	•
1-Butene	C <sub>4</sub> H <sub>8</sub>	•	•	•	•	•	•	•	•	•	•	•
cis-2-Butene	C <sub>4</sub> H <sub>8</sub>	•	•	•	•	•	•	•	•	•	•	•
trans-2-Butene	C <sub>4</sub> H <sub>8</sub>	•	•	•	•	•	•	•	•	•	•	•
Carbon Dioxide	CO <sub>2</sub>	•	•	•	•	•	•	•	•	•	•	U
Carbon Monoxide	CO	•	•	•	•	•	•	I	•	•	•	•
Carbonyl Sulfide	COS	•	•	•	I	•	•	•	I	I	I	I
Chlorine	Cl <sub>2</sub>	U	•	U	U	U	•	•	•	U	U	U
Deuterium	D <sub>2</sub>	•	•	•	•	•	•	•	•	•	•	•
Diborane	B <sub>2</sub> H <sub>6</sub>	•	•	U	I	•	•	I	I	I	I	I
Dichlorosilane	H <sub>2</sub> SiCl <sub>2</sub>	I	•	I	I	I	•	I	I	I	I	I
Dimethyl Ether	C <sub>2</sub> H <sub>6</sub> O	•	•	•	•	•	•	•	•	•	•	I
Ethane	C <sub>2</sub> H <sub>6</sub>	•	•	•	•	•	•	•	•	•	•	•
Ethyl Acetylene	C <sub>4</sub> H <sub>6</sub>	I	•	•	I	U	•	•	I	•	I	I
Ethyl Chloride	C <sub>2</sub> H <sub>5</sub> Cl	•	•	U	I	•	•	•	•	•	•	U
Ethylene	C <sub>2</sub> H <sub>4</sub>	•	•	•	•	•	•	•	•	•	•	I
Ethylene Oxide*	C <sub>2</sub> H <sub>4</sub> O	R3	•	R4	I	U	•	•	U	U	U	U
Ethylene Oxide/Carbon Dioxide Mixtures*		R3	•	I	I	U	•	•	U	U	U	U
Ethylene Oxide/Halocarbon Mixtures*		R3	•	I	I	U	•	•	U	U	U	U
Ethylene Oxide/HCF-124		R3	•	I	I	U	•	•	U	U	U	U
Halocarbon 11	CCl <sub>3</sub> F	•	•	R4	I	•	•	•	•	•	U	U
Halocarbon 12	CCl <sub>2</sub> F <sub>2</sub>	•	•	R4	I	•	•	•	•	•	•	•
Halocarbon 13	CClF <sub>3</sub>	•	•	R4	I	•	•	•	•	•	•	•
Halocarbon 13B1	CBF <sub>3</sub>	•	•	R4	I	•	•	•	•	•	•	•
Halocarbon 14	CF <sub>4</sub>	•	•	R4	I	•	•	•	•	•	•	•

## LEGEND

- Satisfactory for use with the intended gas
- U Unsatisfactory for use with the intended gas
- I Insufficient data available to determine compatibility with the intended gas
- R1 Satisfactory with brass having a low copper content
- R2 Satisfactory with acetylene, however, cylinder gas is dissolved in a solvent (generally acetone) which may be incompatible with these elastomers
- R3 Satisfactory with brass, except where acetylene or acetylides are present
- R4 Generally unsatisfactory, except where specific use conditions have proven acceptable
- R5 Satisfactory below 3000 PSIG (206.9 bar) where gas velocities do not exceed 30 ft./sec.
- R6 Compatibility depends on condition of use



# Compatibility Guide Cont.



COMMON NAME	CHEMICAL FORMULA	MATERIALS OF CONSTRUCTION										
		METALS					PLASTICS		ELASTOMERS			
		Brass	Stainless Steel	Aluminum	Zinc	Copper	PTFE	Teflon®	Viton	Buna-N	Neoprene	Polyurethane
Halocarbon 21	CHCl <sub>2</sub> F	.	.	R4		.	.	.	U	U	.	.
Halocarbon 22	CHClF <sub>2</sub>	.	.	R4		.	.	.	U	U	.	U
Halocarbon 23	CHF <sub>3</sub>	.	.	R4		.	.	.				.
Halocarbon 113	CCl <sub>2</sub> FCClF <sub>2</sub>	.	.	R4	U	.	.	.	.	.	.	.
Halocarbon 114	C <sub>2</sub> Cl <sub>2</sub> F <sub>4</sub>	.	.	R4		.	.	.	.	.	.	.
Halocarbon 115	C <sub>2</sub> ClF <sub>5</sub>	.	.	R4		.	.	.	.	.	.	.
Halocarbon 116	C <sub>2</sub> F <sub>6</sub>	.	.	R4		.	.	.				.
Halocarbon 142B	C <sub>2</sub> H <sub>3</sub> ClF <sub>2</sub>	.	.	R4		.	.	.	U	.	.	.
Halocarbon 152A	C <sub>2</sub> H <sub>4</sub> F <sub>2</sub>	.	.	R4		.	.	.	U	.	.	.
Halocarbon C-318	C <sub>2</sub> F <sub>8</sub>	.	.	R4			.	.	.	.	.	.
Halocarbon 502	CHClF <sub>2</sub> /CClF <sub>2</sub> -CF <sub>3</sub>		.	R4			.	.	.	.	.	.
Halocarbon 1132A	C <sub>2</sub> H <sub>2</sub> F <sub>2</sub>	.	.	R4		.		.				.
Helium	He	.	.	.	.	.	.	.	.	.	.	.
Hydrogen	H <sub>2</sub>	.	.	.	.	.	.	.	.	.	.	.
Hydrogen Chloride	HCl	U	.	U	U	U	.	.	.	U	U	U
Hydrogen Sulfide	H <sub>2</sub> S	U	.	.			.	.	U	.	.	.
Isobutane	C <sub>4</sub> H <sub>10</sub>	.	.	.	.	.	.	.	.	.	.	.
Isobutylene	C <sub>4</sub> H <sub>8</sub>	.	.	.		.	.	.	.	.	.	
Isopentane	C <sub>5</sub> H <sub>12</sub>	.	.	.	.	.	.	.	.	.	.	.
Krypton	Kr	.	.	.	.	.	.	.	.	.	.	.
Methane	CH <sub>4</sub>	.	.	.	.	.	.	.	.	.	.	.
Methyl Chloride	CH <sub>3</sub> Cl	.	.	U	U	.	.	.	.	U	U	U
Methyl Mercaptan	CH <sub>3</sub> SH	.	.	U		U	.	.			.	
Neon	Ne	.	.	.	.	.	.	.	.	.	.	.
Nitric Oxide	NO	U	.	.		.	.	.			.	
Nitrogen	N <sub>2</sub>	.	.	.	.	.	.	.	.	.	.	.
Nitrogen Dioxide	NO <sub>2</sub>		.	.			.	.	U	U	U	U
Nitrous Oxide	N <sub>2</sub> O	.	.	.	.	.	.	.	.	.	.	.
Oxygen	O <sub>2</sub>	.	R5	R4	.	.	.	.	R6	R6	R6	.
Perfluoropropane	C <sub>3</sub> F <sub>8</sub>	.	.	.		.	.	.		.	.	
Phosphine	PH <sub>3</sub>		.	.			.	.				
Phosphorous Pentafluoride	PF <sub>5</sub>		.				.	.				
Propane	C <sub>3</sub> H <sub>8</sub>	.	.	.	.	.	.	.	.	.	.	.
Propylene	C <sub>3</sub> H <sub>6</sub>	.	.	.	.	.	.	.	.	U	U	U
Propylene Oxide	C <sub>3</sub> H <sub>6</sub> O		.				.	.	U	U	U	U
Refrigerant Gases	See Halocarbons											
Silane	SiH <sub>4</sub>	.	.	.		.	.	.	.	.	.	.
Silicon Tetrachloride	SiCl <sub>4</sub>		.	U			.	.				
Silicon Tetrafluoride	SiF <sub>4</sub>	.	.	.		.	.	.	.	.	.	.
Sulfur Dioxide	SO <sub>2</sub>	U	.	.	U	U	.	.	.	U	U	.
Sulfur Hexafluoride	SF <sub>6</sub>	.	.	.		.	.	.	.	.	.	.
Trichlorosilane	HSiCl <sub>3</sub>		.	U			.	.				
Vinyl Methyl Ether	C <sub>3</sub> H <sub>6</sub> O	.	.	.		U	.	.				
Xenon	Xe	.	.	.	.	.	.	.	.	.	.	.



# CONVERSION FACTORS



## PRESSURE

## TO OBTAIN

	atm	bar	ft of H <sub>2</sub> O	in of hg	in of H <sub>2</sub> O	kg/cm <sup>2</sup>	kPa	mm of Hg	PSI
MULTIPLY	BY								
atm	....	1.01325	33.932	29.921	407.1827	1.0332	101.3171	760	14.696
bar	0.98692	....	33.4883	29.530	401.8596	1.019716	100	750.062	14.50368
Ft. of H <sub>2</sub> O	0.02947	0.029891	....	0.882646	12	0.03048	2.9890	22.4198	0.433107
in of Hg	0.03342	0.033864	1.1340	....	13.6	0.034532	3.376895	25.4	0.49115
in of H <sub>2</sub> O	0.00246	0.002499	0.083333	0.073556	....	0.00254	0.0249089	1.86832	0.03609
kg/cm <sup>2</sup>	0.9678	0.980665	32.8084	28.95903	393.7008	....	98.03922	735.5592	14.22334
kPa	0.00987	0.010	0.33456	0.29613	4.01472	0.01020	....	7.5006	0.14504
mm of Hg	0.00132	0.001333	0.044603	0.03937	0.535240	0.001360	0.133322	....	0.019337
PSI	0.06805	0.068948	2.3089	2.0360	27.70851	0.070307	6.89465	51.175	....

## FLOW

## TO OBTAIN

	cm <sup>3</sup> /min	cm <sup>3</sup> /sec	ft <sup>3</sup> /hr	ft <sup>3</sup> /min	m <sup>3</sup> /hr	m <sup>3</sup> /min	L/hr	Lpm
MULTIPLY	BY							
cm <sup>3</sup> /min	....	0.0166667	0.0021189	0.0000353	0.00006	0.000001	0.06	0.001
cm <sup>3</sup> /sec	60	....	0.1271340	0.0021189	0.0036	0.00006	3.6	0.06
ft <sup>3</sup> /hr	471.9474	7.865790	....	0.0166667	0.0283168	0.0004719	28.31685	0.4719474
ft <sup>3</sup> /min	28,316.85	471.9474	60	....	1.699008	0.0283168	1699.008	28.31686
m <sup>3</sup> /hr	16,666.67	277.7778	35.31467	0.5885777	....	0.0166667	1000	16.66667
m <sup>3</sup> /min	1,000,000	16,666.67	2118.876	35.31467	60	....	60,000	1000
L/hr	16.66667	0.2777778	0.0353147	0.0005885	0.001	0.0000167	....	0.0166667
Lpm	1000	16.66667	2.118876	0.0353147	0.06	0.001	60	....

## DENSITY

## TO OBTAIN

	gms/cm <sup>3</sup>	kg/m <sup>3</sup>	lbs/ft <sup>3</sup>	lbs/in <sup>3</sup>	lbs/U.S. gal
MULTIPLY	BY				
gms/cm <sup>3</sup>	....	1000	62.428	0.0361273	8.3454
kg/m <sup>3</sup>	0.001	....	0.062428	3.61273 x 10 <sup>-5</sup>	0.0083454
lbs/ft <sup>3</sup>	0.0160185	16.018463	....	5.78704 x 10 <sup>-4</sup>	0.13368
lbs/in <sup>3</sup>	27.679905	27.679.9	1728	....	231
lbs/U.S. gal	0.1198264	119.8264	7.4805195	0.004329	....

# PRODUCT WARRANTY

This equipment is sold by The Harris Products Group under the warranties and policies set forth in the following paragraphs. The warranty is extended only with respect to the purchase of this equipment directly from The Harris Products Group or its authorized distributor network as new merchandise and is extended to the first buyer thereof other than for the purpose of resale.

The warranty period is one (1) year from the date of original delivery to the buyer with the following exception for equipment use in corrosive gas service. Equipment used in corrosive gas service will have a warranty of ninety (90) days from the date of original delivery. The equipment is warranted to be free from functional defects in materials and workmanship and to conform to the description of this equipment contained in the product manual and any associated labels, inserts or instructions provided that the equipment is properly operated under conditions of normal use and that recommended regular maintenance and service is performed in accordance with the instructions provided.

The warranty for such equipment shall not apply if the equipment has been altered by any third party. The Harris Products Group or its designated service facility shall only perform repairs to the equipment. If the equipment has been subject to abuse, misuse, negligence or accident the stated warranty will not apply.

The Harris Products Group sole obligation to the buyer and the buyer's sole remedy is limited to the repair or replacement of the equipment free of charge at The Harris Products Group's option. The authorized distributor from which it was purchased must report the request for return or repair to The Harris Products Group. The request must include the observed deficiency, the part number or assembly number, gas service used and the proof of purchase. The request for return or repair must occur no later than seven (7) days after the expiration of the warranty period (One year and seven days for non-corrosive equipment and ninety seven (97) days for equipment in corrosive gas service). Transportation charges are to be prepaid for the return of the equipment and upon examination the equipment is found defective due to no fault of the buyer the equipment will be replaced or repaired and returned to the original buyer at no charge. If the product is found to be defective due to negligence of the buyer or his customer the product will be repaired or replaced and returned to the original buyer only after authorization has been received to pay for any such repairs and all transportation charges.

The Harris Products Group shall not be liable for any damages including but not limited to incidental damages, consequential damages or other damages which may occur due to negligence, breach of warranty or otherwise.

There are no express or implied warranties that extend beyond the warranties set forth by The Harris Products Group.

**IF YOU HAVE ISSUES WITH YOUR PRODUCT OR A WARRANTY CLAIM  
CALL 1.800.733.4043**



# IN NEED OF TURNKEY SPECIALTY GAS SYSTEMS? **HARRIS DELIVERS!**

## SKILLFULLY DESIGNED AND BUILT FOR RELIABILITY

- + Harris Products Group has 100 years of experience producing gas delivery systems and control valves you can depend upon
- + We have proven experience with the critical requirements of high-purity specialty gas
- + We are your trusted partner in creating turnkey solutions for those unique requirements



**CONTACT A HARRIS®  
SPEC GAS EXPERT**

1.800.733.4043 option 2

## **5 EASY STEPS** to a *customized configuration*

- 1 Provide the specialty gas application and parameters to Harris
- 2 Harris' technical staff will design a system tailored to the application
- 3 Within 24 hours, Harris will send a quote and a 3-D drawing of the complete system
- 4 Review the design to ensure all customer expectations are met
- 5 Upon approval, Harris will build the system with high-quality components and parts



[harrisproductsgroup.com](http://harrisproductsgroup.com)  
[harrisspecgas@lincolnelectric.com](mailto:harrisspecgas@lincolnelectric.com)

**IF IT USES GAS, IT NEEDS HARRIS.®**



A LINCOLN ELECTRIC COMPANY

The Harris Products Group  
A Lincoln Electric Company  
2345 Murphy Blvd  
Gainesville, GA 30504  
1.800.733.4043

PN: 9505646 REV E  
032021