

Operator's Manual

Cooper™ App

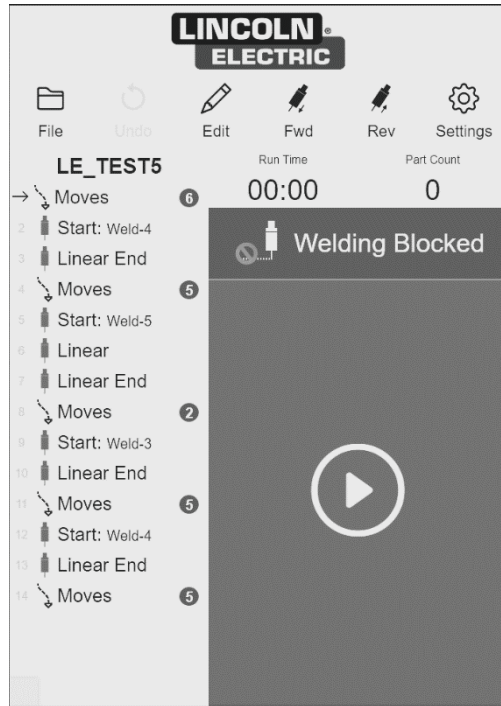

Register your machine:
www.lincolnelectric.com/register
 Authorized Service and Distributor Locator:
www.lincolnelectric.com/locator

Need Help? Call 1.888.935.3878
 to talk to a Service Representative

Hours of Operation:
 8:00 AM to 6:00 PM (ET) Mon. thru Fri.

Save for future reference

Date Purchased

Code: (ex: 10859)

Serial: (ex: U1060512345)

After hours?
 Use "Ask the Experts" at lincolnelectric.com
 A Lincoln Service Representative will contact you
 no later than the following business day.

For Service outside the USA:
 Email: Cobot_Service@LincolnElectric.com

THANK YOU FOR SELECTING A QUALITY PRODUCT BY LINCOLN ELECTRIC.

PLEASE EXAMINE CARTON AND EQUIPMENT FOR DAMAGE IMMEDIATELY

When this equipment is shipped, title passes to the purchaser upon receipt by the carrier. Consequently, claims for material damaged in shipment must be made by the purchaser against the transportation company at the time the shipment is received.

SAFETY DEPENDS ON YOU

Lincoln arc welding and cutting equipment is designed and built with safety in mind. However, your overall safety can be increased by proper installation ... and thoughtful operation on your part. **DO NOT INSTALL, OPERATE OR REPAIR THIS EQUIPMENT WITHOUT READING THIS MANUAL AND THE SAFETY PRECAUTIONS CONTAINED THROUGHOUT.** And, most importantly, think before you act and be careful.

WARNING

This statement appears where the information must be followed exactly to avoid serious personal injury or loss of life.

CAUTION

This statement appears where the information must be followed to avoid minor personal injury or damage to this equipment.

KEEP YOUR HEAD OUT OF THE FUMES.

DON'T get too close to the arc. Use corrective lenses if necessary to stay a reasonable distance away from the arc.

READ and obey the Safety Data Sheet (SDS) and the warning label that appears on all containers of welding materials.

USE ENOUGH VENTILATION or exhaust at the arc, or both, to keep the fumes and gases from your breathing zone and the general area.

IN A LARGE ROOM OR OUTDOORS, natural ventilation may be adequate if you keep your head out of the fumes (See below).

USE NATURAL DRAFTS or fans to keep the fumes away from your face.

If you develop unusual symptoms, see your supervisor. Perhaps the welding atmosphere and ventilation system should be checked.

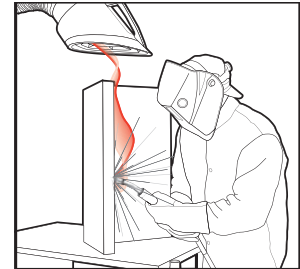

WEAR CORRECT EYE, EAR & BODY PROTECTION

PROTECT your eyes and face with welding helmet properly fitted and with proper grade of filter plate (See ANSI Z49.1).

PROTECT your body from welding spatter and arc flash with protective clothing including woolen clothing, flame-proof apron and gloves, leather leggings, and high boots.

PROTECT others from splatter, flash, and glare with protective screens or barriers.



IN SOME AREAS, protection from noise may be appropriate.

BE SURE protective equipment is in good condition.

Also, wear safety glasses in work area
AT ALL TIMES.



SPECIAL SITUATIONS

DO NOT WELD OR CUT containers or materials which previously had been in contact with hazardous substances unless they are properly cleaned. This is extremely dangerous.

DO NOT WELD OR CUT painted or plated parts unless special precautions with ventilation have been taken. They can release highly toxic fumes or gases.

Additional precautionary measures

PROTECT compressed gas cylinders from excessive heat, mechanical shocks, and arcs; fasten cylinders so they cannot fall.

BE SURE cylinders are never grounded or part of an electrical circuit.

REMOVE all potential fire hazards from welding area.

ALWAYS HAVE FIRE FIGHTING EQUIPMENT READY FOR IMMEDIATE USE AND KNOW HOW TO USE IT.





SECTION A: WARNINGS



CALIFORNIA PROPOSITION 65 WARNINGS



WARNING: Breathing diesel engine exhaust exposes you to chemicals known to the State of California to cause cancer and birth defects, or other reproductive harm.

- Always start and operate the engine in a well-ventilated area.
- If in an exposed area, vent the exhaust to the outside.
- Do not modify or tamper with the exhaust system.
- Do not idle the engine except as necessary.

For more information go to www.P65warnings.ca.gov/diesel

WARNING: This product, when used for welding or cutting, produces fumes or gases which contain chemicals known to the State of California to cause birth defects and, in some cases, cancer. (California Health & Safety Code § 25249.5 et seq.)



WARNING: Cancer and Reproductive Harm
www.P65warnings.ca.gov

ARC WELDING CAN BE HAZARDOUS. PROTECT YOURSELF AND OTHERS FROM POSSIBLE SERIOUS INJURY OR DEATH. KEEP CHILDREN AWAY. PACEMAKER WEARERS SHOULD CONSULT WITH THEIR DOCTOR BEFORE OPERATING.

Read and understand the following safety highlights. For additional safety information, it is strongly recommended that you purchase a copy of "Safety in Welding & Cutting - ANSI Standard Z49.1" from the American Welding Society, P.O. Box 351040, Miami, Florida 33135 or CSA Standard W117.2. A Free copy of "Arc Welding Safety" booklet E205 is available from the Lincoln Electric Company, 22801 St. Clair Avenue, Cleveland, Ohio 44117-1199.

BE SURE THAT ALL INSTALLATION, OPERATION, MAINTENANCE AND REPAIR PROCEDURES ARE PERFORMED ONLY BY QUALIFIED INDIVIDUALS.







FOR ENGINE POWERED EQUIPMENT.

- Turn the engine off before troubleshooting and maintenance work unless the maintenance work requires it to be running.
- Do not add the fuel near an open flame welding arc or when the engine is running. Stop the engine and allow it to cool before refueling to prevent spilled fuel from vaporizing on contact with hot engine parts and igniting. Do not spill fuel when filling tank. If fuel is spilled, wipe it



up and do not start engine until fumes have been eliminated.

- Keep all equipment safety guards, covers and devices in position and in good repair. Keep hands, hair, clothing and tools away from V-belts, gears, fans and all other moving parts when starting, operating or repairing equipment.
 
- In some cases it may be necessary to remove safety guards to perform required maintenance. Remove guards only when necessary and replace them when the maintenance requiring their removal is complete. Always use the greatest care when working near moving parts.
- Do not put your hands near the engine fan. Do not attempt to override the governor or idler by pushing on the throttle control rods while the engine is running.
- To prevent accidentally starting gasoline engines while turning the engine or welding generator during maintenance work, disconnect the spark plug wires, distributor cap or magneto wire as appropriate.
- To avoid scalding, do not remove the radiator pressure cap when the engine is hot.
 
- Using a generator indoors CAN KILL YOU IN MINUTES.
- Generator exhaust contains carbon monoxide. This is a poison you cannot see or smell.
- NEVER use inside a home or garage, EVEN IF doors and windows are open.
 
- Only use OUTSIDE and far away from windows, doors and vents.
 
- Avoid other generator hazards. READ MANUAL BEFORE USE.



ELECTRIC AND MAGNETIC FIELDS MAY BE DANGEROUS



- Electric current flowing through any conductor causes localized Electric and Magnetic Fields (EMF). Welding current creates EMF fields around welding cables and welding machines.
- EMF fields may interfere with some pacemakers, and welders having a pacemaker should consult their physician before welding.
- Exposure to EMF fields in welding may have other health effects which are now not known.
- All welders should use the following procedures in order to minimize exposure to EMF fields from the welding circuit:
 - Route the electrode and work cables together - Secure them with tape when possible.
 - Never coil the electrode lead around your body.
 - Do not place your body between the electrode and work cables. If the electrode cable is on your right side, the work cable should also be on your right side.
 - Connect the work cable to the workpiece as close as possible to the area being welded.
 - Do not work next to welding power source.



ELECTRIC SHOCK CAN KILL.



- 3.a. The electrode and work (or ground) circuits are electrically “hot” when the welder is on. Do not touch these “hot” parts with your bare skin or wet clothing. Wear dry, hole-free gloves to insulate hands.
- 3.b. Insulate yourself from work and ground using dry insulation. Make certain the insulation is large enough to cover your full area of physical contact with work and ground.

In addition to the normal safety precautions, if welding must be performed under electrically hazardous conditions (in damp locations or while wearing wet clothing; on metal structures such as floors, gratings or scaffolds; when in cramped positions such as sitting, kneeling or lying, if there is a high risk of unavoidable or accidental contact with the workpiece or ground) use the following equipment:

- Semiautomatic DC Constant Voltage (Wire) Welder.
 - DC Manual (Stick) Welder.
 - AC Welder with Reduced Voltage Control.
- 3.c. In semiautomatic or automatic wire welding, the electrode, electrode reel, welding head, nozzle or semiautomatic welding gun are also electrically “hot”.
 - 3.d. Always be sure the work cable makes a good electrical connection with the metal being welded. The connection should be as close as possible to the area being welded.
 - 3.e. Ground the work or metal to be welded to a good electrical (earth) ground.
 - 3.f. Maintain the electrode holder, work clamp, welding cable and welding machine in good, safe operating condition. Replace damaged insulation.
 - 3.g. Never dip the electrode in water for cooling.
 - 3.h. Never simultaneously touch electrically “hot” parts of electrode holders connected to two welders because voltage between the two can be the total of the open circuit voltage of both welders.
 - 3.i. When working above floor level, use a safety belt to protect yourself from a fall should you get a shock.
 - 3.j. Also see Items 6.c. and 8.



ARC RAYS CAN BURN.



- 4.a. Use a shield with the proper filter and cover plates to protect your eyes from sparks and the rays of the arc when welding or observing open arc welding. Headshield and filter lens should conform to ANSI Z87.1 standards.
- 4.b. Use suitable clothing made from durable flame-resistant material to protect your skin and that of your helpers from the arc rays.
- 4.c. Protect other nearby personnel with suitable, non-flammable screening and/or warn them not to watch the arc nor expose themselves to the arc rays or to hot spatter or metal.



FUMES AND GASES CAN BE DANGEROUS.



- 5.a. Welding may produce fumes and gases hazardous to health. Avoid breathing these fumes and gases. When welding, keep your head out of the fume. Use enough ventilation and/or exhaust at the arc to keep fumes and gases away from the breathing zone. **When welding hardfacing (see instructions on container or SDS) or on lead or cadmium plated steel and other metals or coatings which produce highly toxic fumes, keep exposure as low as possible and within applicable OSHA PEL and ACGIH TLV limits using local exhaust or mechanical ventilation unless exposure assessments indicate otherwise. In confined spaces or in some circumstances, outdoors, a respirator may also be required. Additional precautions are also required when welding on galvanized steel.**
5. b. The operation of welding fume control equipment is affected by various factors including proper use and positioning of the equipment, maintenance of the equipment and the specific welding procedure and application involved. Worker exposure level should be checked upon installation and periodically thereafter to be certain it is within applicable OSHA PEL and ACGIH TLV limits.
- 5.c. Do not weld in locations near chlorinated hydrocarbon vapors coming from degreasing, cleaning or spraying operations. The heat and rays of the arc can react with solvent vapors to form phosgene, a highly toxic gas, and other irritating products.
- 5.d. Shielding gases used for arc welding can displace air and cause injury or death. Always use enough ventilation, especially in confined areas, to insure breathing air is safe.
- 5.e. Read and understand the manufacturer’s instructions for this equipment and the consumables to be used, including the Safety Data Sheet (SDS) and follow your employer’s safety practices. SDS forms are available from your welding distributor or from the manufacturer.
- 5.f. Also see item 1.j.



WELDING AND CUTTING SPARKS CAN CAUSE FIRE OR EXPLOSION.



- 6.a. Remove fire hazards from the welding area. If this is not possible, cover them to prevent the welding sparks from starting a fire. Remember that welding sparks and hot materials from welding can easily go through small cracks and openings to adjacent areas. Avoid welding near hydraulic lines. Have a fire extinguisher readily available.
- 6.b. Where compressed gases are to be used at the job site, special precautions should be used to prevent hazardous situations. Refer to "Safety in Welding and Cutting" (ANSI Standard Z49.1) and the operating information for the equipment being used.
- 6.c. When not welding, make certain no part of the electrode circuit is touching the work or ground. Accidental contact can cause overheating and create a fire hazard.
- 6.d. Do not heat, cut or weld tanks, drums or containers until the proper steps have been taken to insure that such procedures will not cause flammable or toxic vapors from substances inside. They can cause an explosion even though they have been "cleaned". For information, purchase "Recommended Safe Practices for the Preparation for Welding and Cutting of Containers and Piping That Have Held Hazardous Substances", AWS F4.1 from the American Welding Society (see address above).
- 6.e. Vent hollow castings or containers before heating, cutting or welding. They may explode.
- 6.f. Sparks and spatter are thrown from the welding arc. Wear oil free protective garments such as leather gloves, heavy shirt, cuffless trousers, high shoes and a cap over your hair. Wear ear plugs when welding out of position or in confined places. Always wear safety glasses with side shields when in a welding area.
- 6.g. Connect the work cable to the work as close to the welding area as practical. Work cables connected to the building framework or other locations away from the welding area increase the possibility of the welding current passing through lifting chains, crane cables or other alternate circuits. This can create fire hazards or overheat lifting chains or cables until they fail.
- 6.h. Also see item 1.b.
- 6.i. Read and follow NFPA 51B "Standard for Fire Prevention During Welding, Cutting and Other Hot Work", available from NFPA, 1 Batterymarch Park, PO box 9101, Quincy, MA 022690-9101.
- 6.j. Do not use a welding power source for pipe thawing.



CYLINDER MAY EXPLODE IF DAMAGED.



- 7.a. Use only compressed gas cylinders containing the correct shielding gas for the process used and properly operating regulators designed for the gas and pressure used. All hoses, fittings, etc. should be suitable for the application and maintained in good condition.
- 7.b. Always keep cylinders in an upright position securely chained to an undercarriage or fixed support.
- 7.c. Cylinders should be located:
 - Away from areas where they may be struck or subjected to physical damage.
 - A safe distance from arc welding or cutting operations and any other source of heat, sparks, or flame.
- 7.d. Never allow the electrode, electrode holder or any other electrically "hot" parts to touch a cylinder.
- 7.e. Keep your head and face away from the cylinder valve outlet when opening the cylinder valve.
- 7.f. Valve protection caps should always be in place and hand tight except when the cylinder is in use or connected for use.
- 7.g. Read and follow the instructions on compressed gas cylinders, associated equipment, and CGA publication P-1, "Precautions for Safe Handling of Compressed Gases in Cylinders," available from the Compressed Gas Association, 14501 George Carter Way Chantilly, VA 20151.



FOR ELECTRICALLY POWERED EQUIPMENT.



- 8.a. Turn off input power using the disconnect switch at the fuse box before working on the equipment.
- 8.b. Install equipment in accordance with the U.S. National Electrical Code, all local codes and the manufacturer's recommendations.
- 8.c. Ground the equipment in accordance with the U.S. National Electrical Code and the manufacturer's recommendations.

Refer to
<http://www.lincolnelectric.com/safety>
for additional safety information.

ELECTROMAGNETIC COMPATIBILITY (EMC)

CONFORMANCE

Products displaying the CE mark are in conformity with European Community Council Directive of 15 Dec 2004 on the approximation of the laws of the Member States relating to electromagnetic compatibility, 2014/30/EU. It was manufactured in conformity with a national standard that implements a harmonized standard: EN 60974-10 Electromagnetic Compatibility (EMC) Product Standard for Arc Welding Equipment. It is for use with other Lincoln Electric equipment. It is designed for industrial and professional use.

INTRODUCTION

All electrical equipment generates small amounts of electromagnetic emission. Electrical emission may be transmitted through power lines or radiated through space, similar to a radio transmitter. When emissions are received by other equipment, electrical interference may result. Electrical emissions may affect many kinds of electrical equipment; other nearby welding equipment, radio and TV reception, numerical controlled machines, telephone systems, computers, etc.

Warning: This Class A equipment is not intended for use in residential locations where the electrical power is provided by the public low-voltage supply system. There may be potential difficulties in ensuring electro-magnetic compatibility in those locations, due to conducted as well as radiated disturbances.

This machine has been designed to operate in an industrial area. The operator must install and operate this equipment as described in this manual. If any electromagnetic disturbances are detected the operator must put in place corrective actions to eliminate these disturbances with, if necessary, assistance from Lincoln Electric. This equipment does not comply with IEC 61000-3-12. If it is connected to a public low-voltage system, it is responsibility of the installer or user of the equipment to ensure, by consultation with the distribution network operator if necessary, that the equipment may be connected.

INSTALLATION AND USE

The user is responsible for installing and using the welding equipment according to the manufacturer's instructions.

If electromagnetic disturbances are detected then it shall be the responsibility of the user of the welding equipment to resolve the situation with the technical assistance of the manufacturer. In some cases this remedial action may be as simple as earthing (grounding) the welding circuit, see Note. In other cases it could involve constructing an electromagnetic screen enclosing the power source and the work complete with associated input filters. In all cases electromagnetic disturbances must be reduced to the point where they are no longer troublesome.

Note: The welding circuit may or may not be earthed for safety reasons. Follow your local and national standards for installation and use. Changing the earthing arrangements should only be authorized by a person who is competent to assess whether the changes will increase the risk of injury, e.g., by allowing parallel welding current return paths which may damage the earth circuits of other equipment.

ASSESSMENT OF AREA

Before installing welding equipment the user shall make an assessment of potential electromagnetic problems in the surrounding area. The following shall be taken into account:

- a) other supply cables, control cables, signaling and telephone cables; above, below and adjacent to the welding equipment;
- b) radio and television transmitters and receivers;
- c) computer and other control equipment;
- d) safety critical equipment, e.g., guarding of industrial equipment;
- e) the health of the people around, e.g., the use of pacemakers and hearing aids;
- f) equipment used for calibration or measurement;
- g) the immunity of other equipment in the environment. The user shall ensure that other equipment being used in the environment is compatible. This may require additional protection measures;
- h) the time of day that welding or other activities are to be carried out.

The size of the surrounding area to be considered will depend on the structure of the building and other activities that are taking place. The surrounding area may extend beyond the boundaries of the premises.

METHODS OF REDUCING EMISSIONS

Public Supply System

Welding equipment should be connected to the public supply system according to the manufacturer's recommendations. If interference occurs, it may be necessary to take additional precautions such as filtering of the system. Consideration should be given to shielding the supply cable of permanently installed welding equipment, in metallic conduit or equivalent. Shielding should be electrically continuous throughout its length. The shielding should be connected to the welding power source so that good electrical contact is maintained between the conduit and the welding power source enclosure.

Maintenance of the Welding Equipment

The welding equipment should be routinely maintained according to the manufacturer's recommendations. All access and service doors and covers should be closed and properly fastened when the welding equipment is in operation. The welding equipment should not be modified in any way except for those changes and adjustments covered in the manufacturer's instructions. In particular, the spark gaps of arc striking and stabilizing devices should be adjusted and maintained according to the manufacturer's recommendations.

Welding Cables

The welding cables should be kept as short as possible and should be positioned close together, running at or close to the floor level.

Equipotential Bonding

Bonding of all metallic components in the welding installation and adjacent to it should be considered. However, metallic components bonded to the work piece will increase the risk that the operator could receive a shock by touching these metallic components and the electrode at the same time. The operator should be insulated from all such bonded metallic components.

Earthing of the Workpiece

Where the workpiece is not bonded to earth for electrical safety, nor connected to earth because of its size and position, e.g., ship's hull or building steelwork, a connection bonding the workpiece to earth may reduce emissions in some, but not all instances. Care should be taken to prevent the earthing of the workpiece increasing the risk of injury to users, or damage to other electrical equipment. Where necessary, the connection of the workpiece to earth should be made by a direct connection to the workpiece, but in some countries where direct connection is not permitted, the bonding should be achieved by suitable capacitance, selected according to national regulations.

Screening and Shielding

Selective screening and shielding of other cables and equipment in the surrounding area may alleviate problems of interference. Screening of the entire welding installation may be considered for special applications.

TABLE OF CONTENTS

TABLE OF CONTENTS 1-1

Preparation and Setup 1-1

 Introduction to the Cooper App..... 1-1

 Navigate to the Cooper App on CRX..... 1-2

 How to Initialize Weld Data..... 1-3

 How To Change Language..... 1-4

 Setting Up Consumables 1-5

 How to Migrate Weld Data..... 1-7

User Interface–Standard Weld Features 2-1

 Programming A Linear Weld 2-1

 Programming a Circular Weld 2-2

 Using Weld By Numbers 2-4

 How to Set a Default Weld 2-5

 Capturing Air Moves 2-6

 How to Add Air Moves 2-7

 How to Edit Air Moves 2-8

 How to Edit a Program 2-10

 How To Resolve Unverified Moves 2-11

 How to Set Multiple Arc Starts 2-13

 Creating a Custom Weld 2-14

 Importing Custom Welds 2-17

 Advanced Editing Of Weld Data 2-19

 How to Set Crater Fill 2-22

 Weld Angle Tuner..... 2-23

 Optimizing Weld Points 2-25

 Programming a Pattern 2-27

 Program Batcher–Scheduler 2-31

 How to Use Tack Mode 2-33

User Interface–Advanced Weld Features 3-1

 Programming a Stitch Weld 3-1

 Search 3-3

 Thru-Arc™ Tracking 3-8

 Multi-pass Welding 3-9

 Create A Multipass Template 3-11

 Applying a Multipass Template..... 3-13

TABLE OF CONTENTS



Programming with External Axes	4-1
How to Jog External with Axes	4-1
How To Teach a Program with a Rail	4-3
How to Teach a Program with Positioner	4-5
How To Teach a Program with a Dual Station Setup	4-8
Cobot Torch Maintenance	5-1
How to teach Tool Center Point (TCP)	5-1
How To Set Up Power Ream Plus (CRX only)	5-4
Service Routines Scheduler	5-10
How To Use Power Ream Plus	5-13
Glossary	Glossary-1

Section 1PREPARATION AND SETUP**INTRODUCTION TO THE COOPER APP**

The Cooper App allows the user to create multiple forms of welding from single pass welds to structural multi-pass welds in simplified steps. The Cooper App has on-screen steps that allows the user to easily program welds, modify weld positions, weld process tracking, and more. Throughout this manual there will be detailed information and steps on how to set up and run the Cooper App.

The Cooper app offers video tutorials.	
For PC users, please use the URL below:	For mobile users, please use the QR code below:
https://www.lincolnelectric.com/cobotresources	

NAVIGATE TO THE COOPER APP ON CRX

Note: Refer to the installation manual for steps to install the Cooper App.

1. Cycle power on the controller. Refer to the Operators Manual for more information.
2. Select the drop-down menu and expand the PLUGINS menu (1).
3. Select Cooper_App (2). The user will now be directed to the Cooper App.

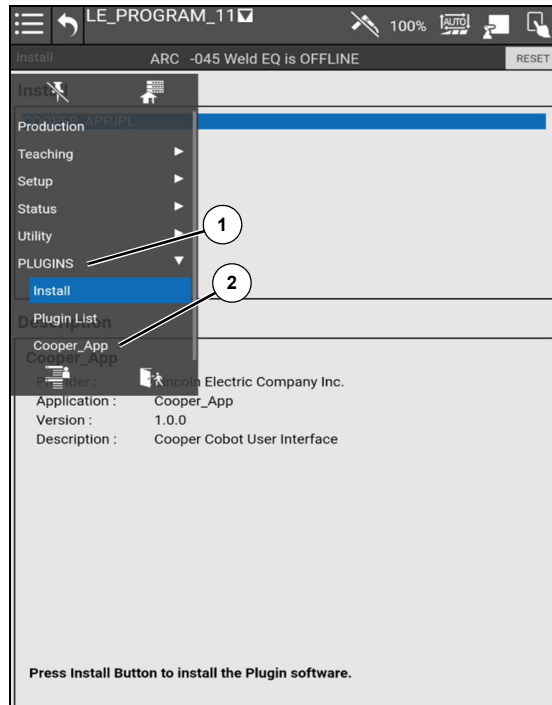

Figure 1-1

HOW TO INITIALIZE WELD DATA

The operator will be prompted to Load Lincoln Electric Weld Data (1). See *Setting Up Consumables* on page 1-5 for more information. This will load Lincoln Electric's predefined weld by number data sets on to the operator's system, see *Using Weld By Numbers* on page 2-4 for more information.

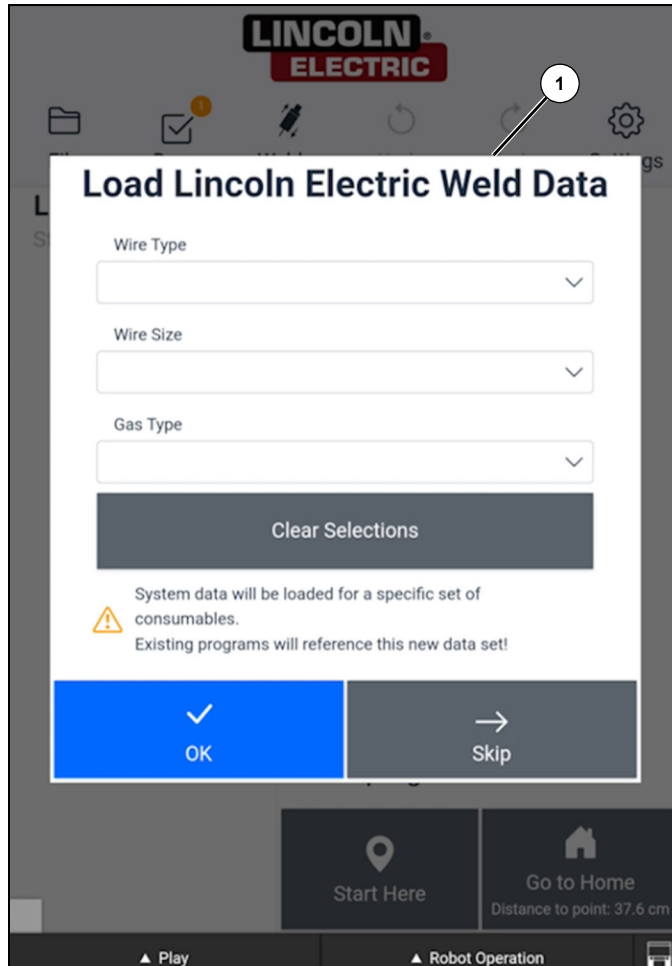

Figure 1-2

- If the operator is not using Lincoln Electric's data sets, the operator has the option to skip this step. The operator will now be prompted to Import Custom Weld Data (2). See *Importing Custom Welds* on page 2-17.

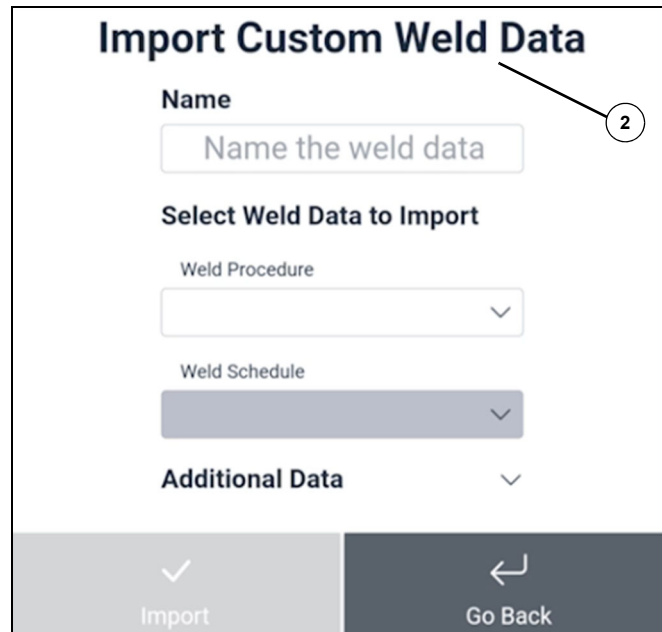

Figure 1-3

- Select OK or exit to complete the process.

HOW TO CHANGE LANGUAGE

- Select the Settings icon (1) and select the language (2) that the Cooper App is currently presented in.

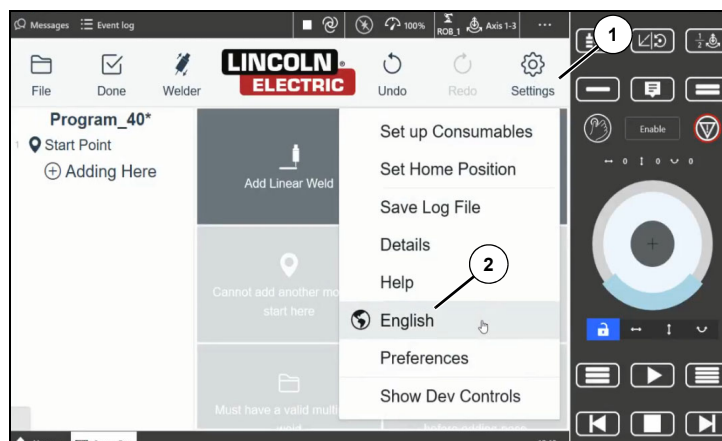

Figure 1-4

- Select the desired language from the pop-up window. The Cooper App will now reload in the selected language.

SETTING UP CONSUMABLES

Note: The first time the Cooper App is loaded onto the system, the user will need to set up the consumables the environment has. See *How to Initialize Weld Data on page 1-3* for more information.

1. Navigate to the top right Settings icon (1) and select Load Lincoln Electric Weld Data (2).

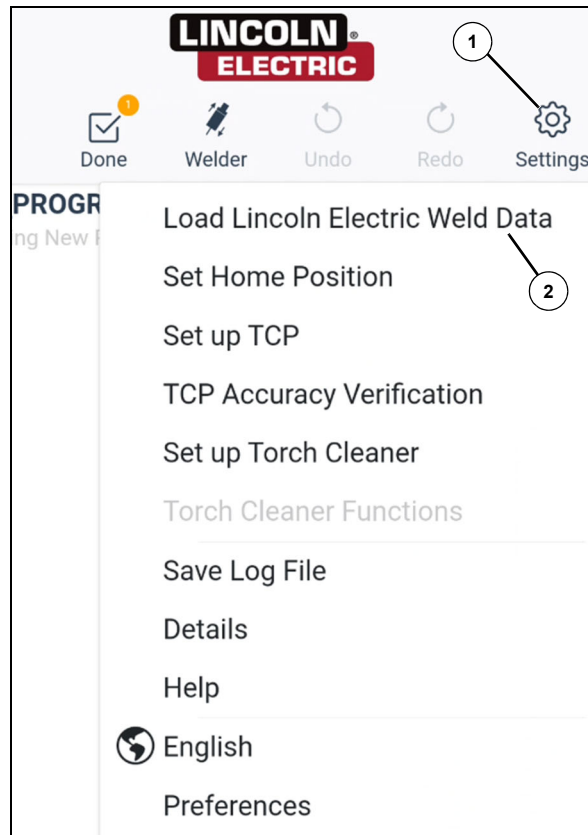

Figure 1-5

Here the user will be able to set up which Wire Type (3), Wire Size (4), and Gas Type (5) the robot will be using to weld. Selecting the wire type first will automate the correct selections of the wire size used on that wire type. The gas type selections will be based off of the selections of the wire type and wire size.

2. Selecting the OK icon (6), the user will load the Lincoln Electric Weldset Database that creates all the weld schedules and procedures associated with the consumables selected which are located in the weld by numbers selections. See *Creating a Custom Weld on page 2-14*.

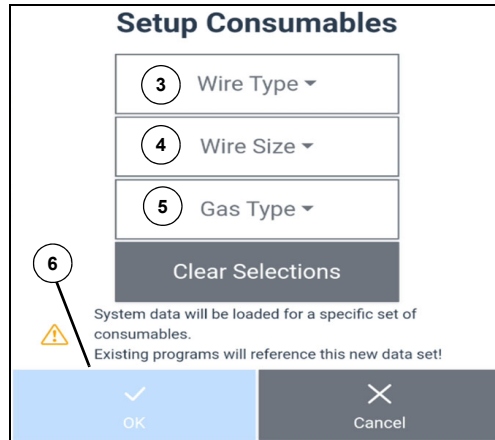

Figure 1-6

HOW TO MIGRATE WELD DATA

Migrating weld data is for an operator who has updated the Cooper App to version 1.7 or newer and has weld data saved that does not follow the new Cooper App format. The new format is a weld procedure with schedule 1 holding the main primary weld data and schedule 2 holding the crater fill data. The operator will be guided on how to migrate data over to the new format.

1. Select Next (1) to see all of the available custom weld data on the system.

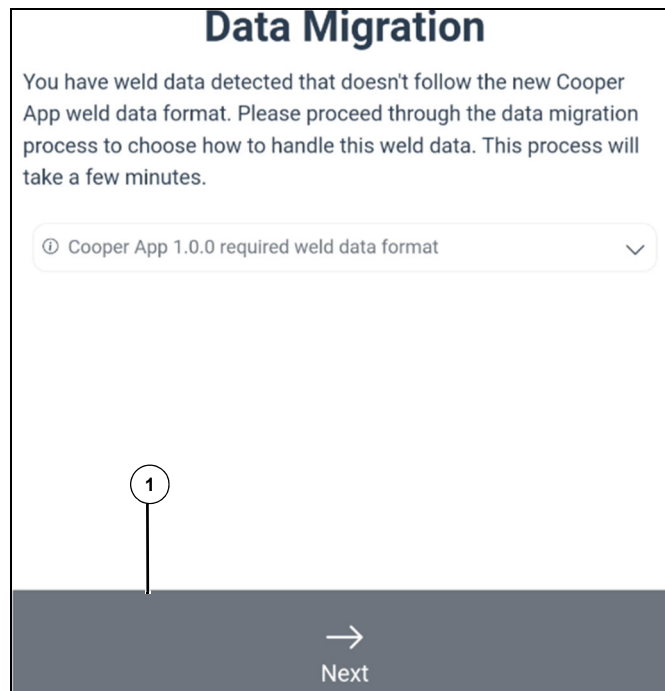

Figure 1-7

2. Selecting the drop-down on a compatible weld will show what the changes are that will be made to adapt the existing custom weld to the new format. On the left side, the operator can select or deselect any custom weld data to be migrated over.

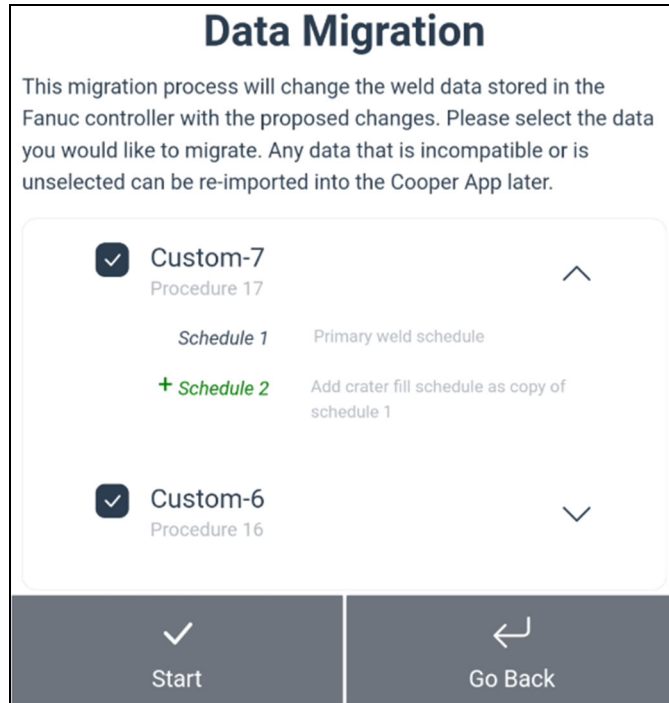

Figure 1-8

3. Selecting the drop-down on a non-compatible weld will give reasons on why the weld cannot be migrated into the new format. The welds can still be modified outside the Cooper App to a compatible format.

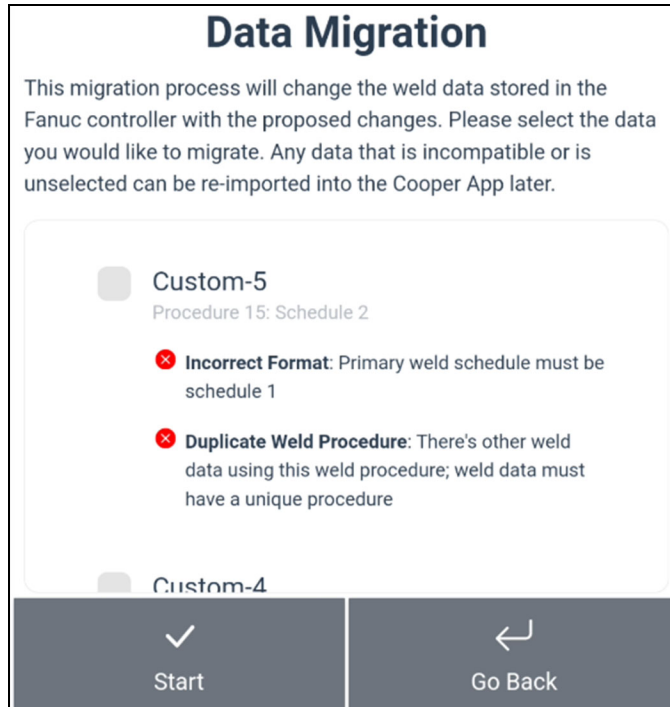

Figure 1-9

- Once the appropriate weld data has been selected, select start and then select proceed. This will begin the process of data migration. After completion, the Cooper App will provide the operator a list of changes made for review.

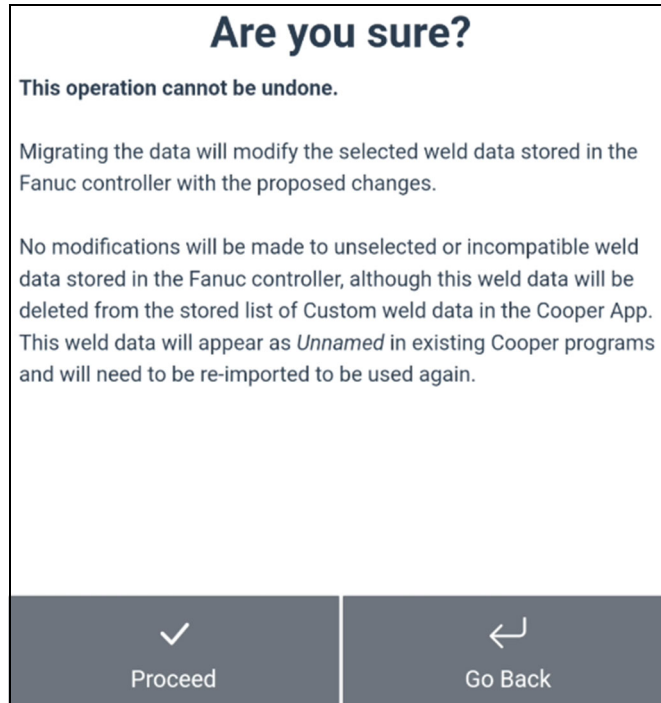

Figure 1-10

Section 2

USER INTERFACE—STANDARD WELD FEATURES

PROGRAMMING A LINEAR WELD

1. Send the robot to the Home position (1).
2. Select the Start Here icon (2).

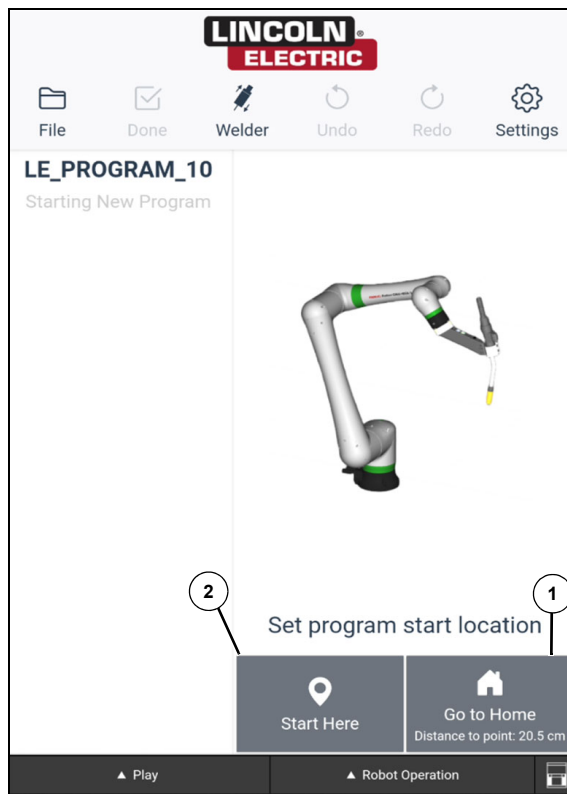

Figure 2-1

3. Press the blue button (3) to unlock the robot.
4. Move the robot to the weld start position and press the green button (4).
5. Move the robot to the end weld position and press and hold the green button.

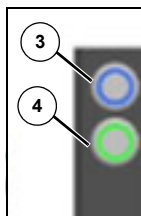

Figure 2-2

6. Move the robot away from the part and select the Done icon.

To run the program, select the Green play button on the tablet or hit the green START button (5) on the operator panel.



Figure 2-3

PROGRAMMING A CIRCULAR WELD

1. Send the robot to the Home position (1).
2. Select Start Here icon (2).

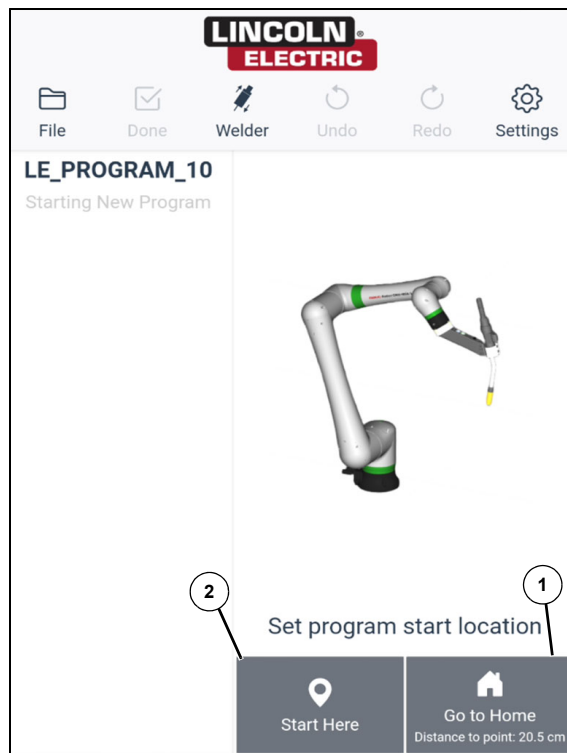

Figure 2-4

3. Press the blue button (3) to unlock the robot. Start moving the robot to the desired position.

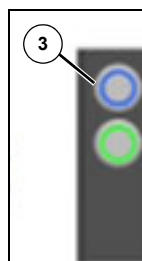

Figure 2-5

4. Select the More Choices icon (4).

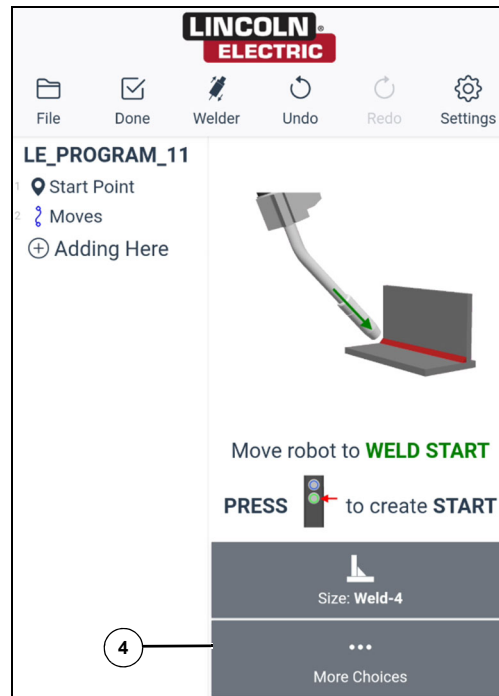

Figure 2-6

5. Select the Add Circular Weld icon (5).

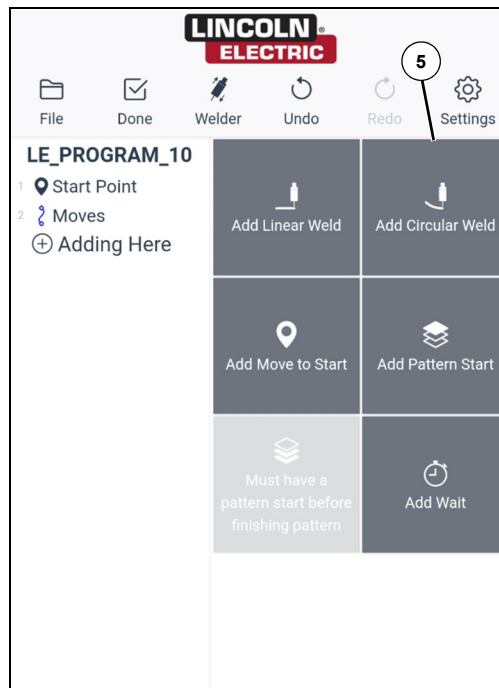

Figure 2-7

6. Move the robot to the weld start position and press the green button (5).

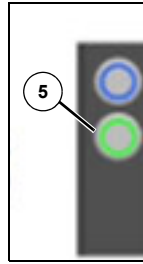

Figure 2-8

7. Move the robot in the desired circular movement, pressing the green button at each weld point.

Note: To program a full circle, the program needs at least five points. Circle points can not be taught greater than 90 degrees apart.

8. Move the robot to the end weld position and press and hold the green button.

9. Move the robot away from the part and select the done icon.

USING WELD BY NUMBERS

When creating a weld point, the operator will be given the option of Size: Weld-4. To change the weld size, select Size: Weld (1).

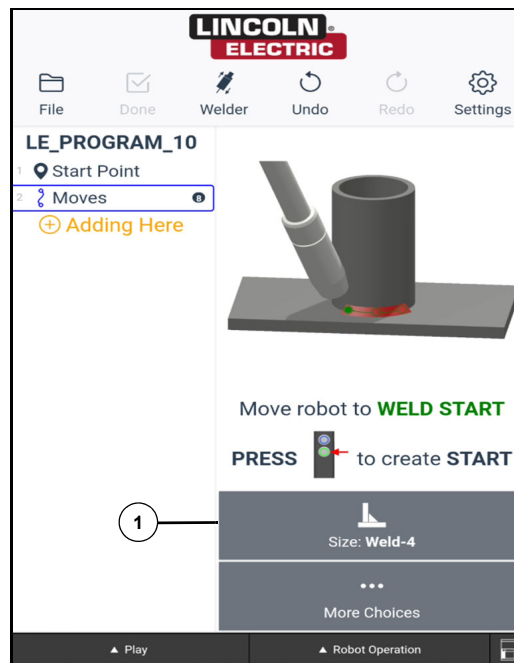

Figure 2-9

The weld by numbers screen is based on the information input from setting up consumables when the Cooper App was initially set up. Each of the numbers on the weld by numbers screen represents a weld size and material thickness. Based on the current welding materials, select the appropriate number. All of the welding parameters in the weld schedule will be automatically populated.

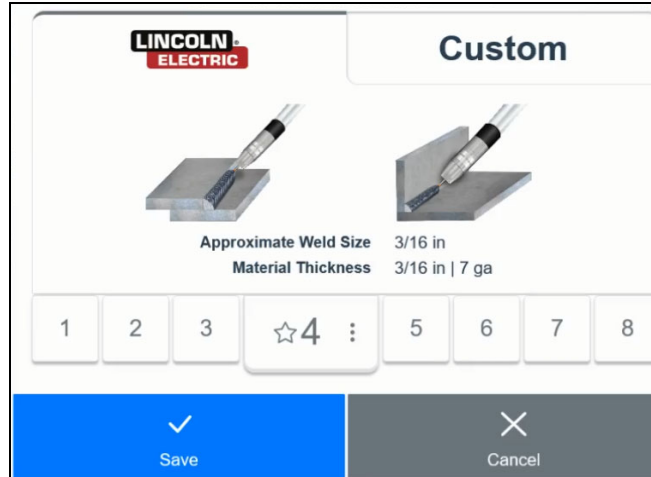

Figure 2-10

HOW TO SET A DEFAULT WELD

By using an existing program, go the WELD START block and select Edit. Select Size: Weld will bring up the weld by numbers screen, see *Using Weld By Numbers on page 2-4* for more information.

The weld number with a star (1) next to it indicates that it is the default weld. To change the default line weld, select the desired weld and then the three dots (2) on the right side. This will give the operator the selection to Set as default (3). Select Save (5) to apply the changes.

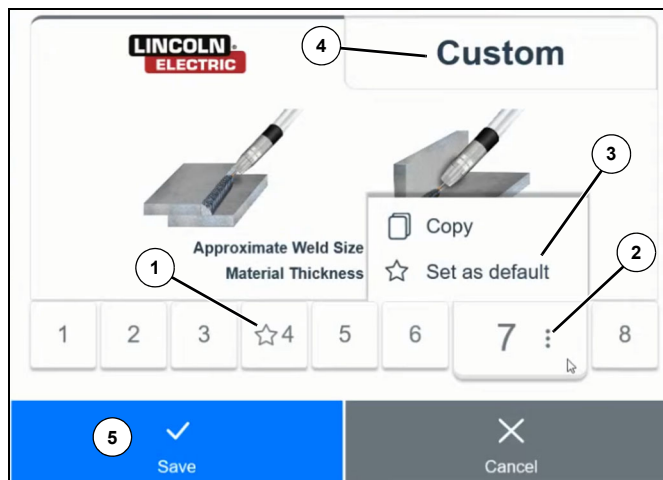

Figure 2-11

To set a custom weld as the default weld, go into the Custom tab (4) and select the three dots (5). This will give the operator the selection to set as default. Select Save to apply the changes.

For any new program in the Cooper App, the default weld will be automatically selected for the welding parameters in a new program.

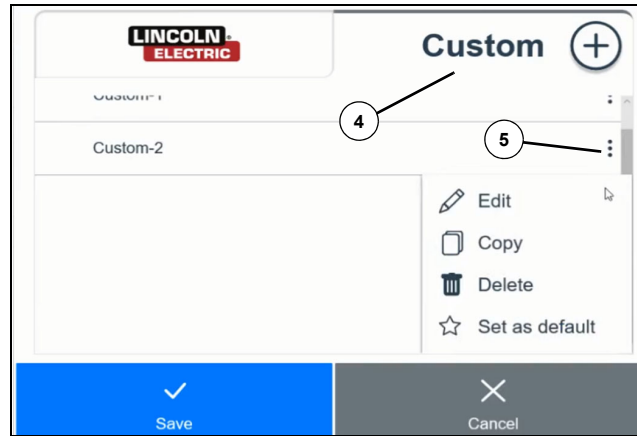

Figure 2-12

CAPTURING AIR MOVES

Note: The Cooper App will automatically capture air motion when the robot is in an active workflow at all times except for when the user is being instructed to teach weld points or pattern part points. An active workflow is defined as anytime the Cooper App is directing the user what to do next.

The operator can see points being recorded on the move block as they move the robot as indicated by the move blocks counter (1). When the program is complete and the Done icon (2) has been selected, the Cooper App will automatically filter out any unneeded motion. If the captured motion has not met the desired smoothness, go into the Edit mode and select the Smooth Motion icon (3).



Figure 2-13

HOW TO ADD AIR MOVES

1. Select a program to add an air move to.
2. Select the location in the program where the air move is to be placed.
3. Select the More Choices icon.
4. Select Add Moves (1). This will bring the operator to the Recording Moves work flow.



Figure 2-14

5. The operator can now unlock the robot and move the robot to the desired position. As the robot is being adjusted, the Cooper App is recording the motion.
6. Once the operator has completed the air motion to be added, select Complete (2). If the operator would like to retry the motion, select Restart (3) and follow steps 5 and 6 again.

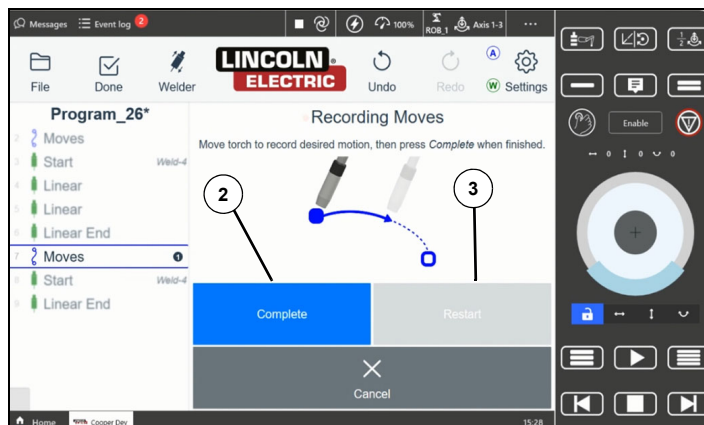

Figure 2-15

HOW TO EDIT AIR MOVES

1. To edit an existing air move, go into Edit mode and select the air move block (1) that will be changed and then select Edit (2).

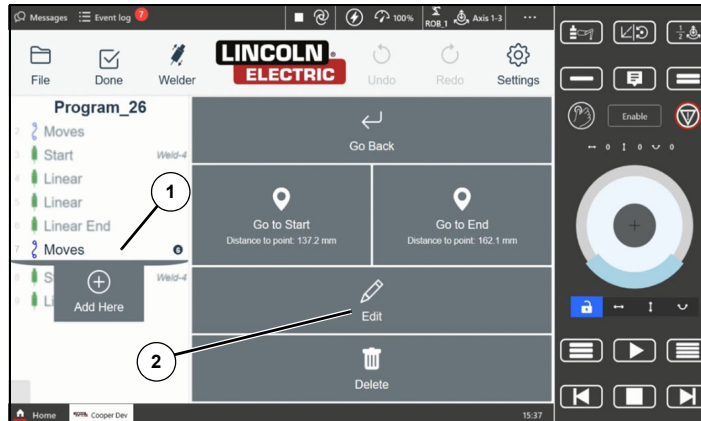

Figure 2-16

2. The Cooper App will give the operator two options: Smooth Motion (3) (this will remove any rigid or sharp points) or Re-Record (4).

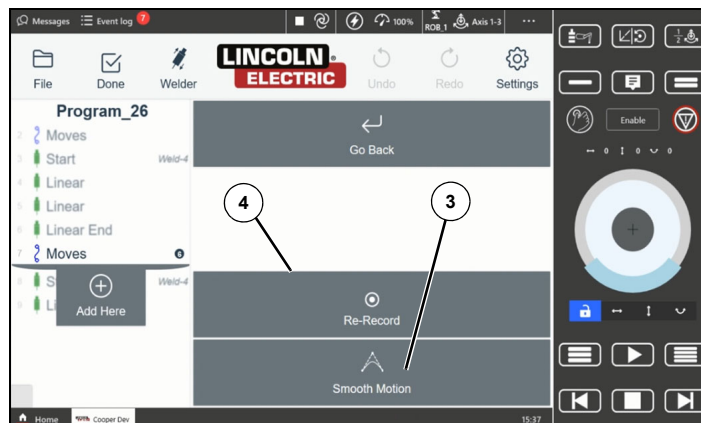

Figure 2-17

3. To re-record, the operator will be prompted to go to the last program block. This is the last known location before the air moves block.

4. Next, the operator will have a few options:
 - Press the blue button (5) to unlock the robot and manually move the robot and record the path. Then select Go to Next Program Block to finish off the moves. Select Complete to finish.
5. Select Go to Next Program Block (6). This will move the Cobot in a direct path to the next block in the program following the moves, then select Complete.

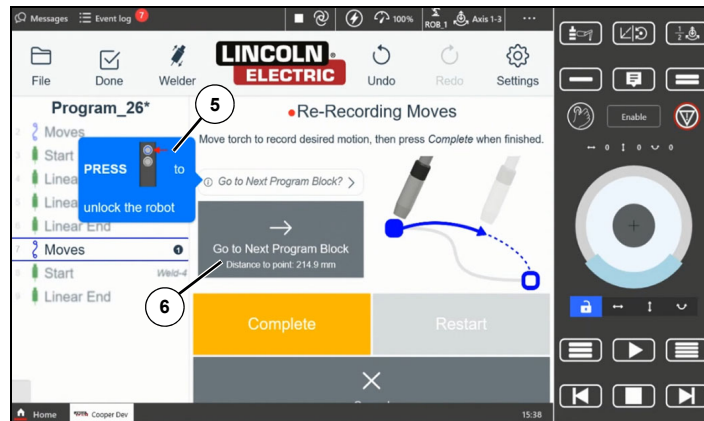

Figure 2-18

Note: If Complete is selected and the Cobot is not yet at the location of the next program block, this will result in unverified moves. See *How To Resolve Unverified Moves* on page 2-11 for more information.

HOW TO EDIT A PROGRAM

Create a program, see *Programming A Linear Weld on page 2-1*, and enter Run mode and run the program. If one of the points is not at the desired location during the weld, the operator can edit the weld moves by following the steps below:

1. Go into Edit mode.
2. Select the point to be edited.
3. Select Go to Position (1) to view the current taught position of the point.
4. Unlock the robot and move the robot into the position that is to be modified.
5. Select Modify Position (2).

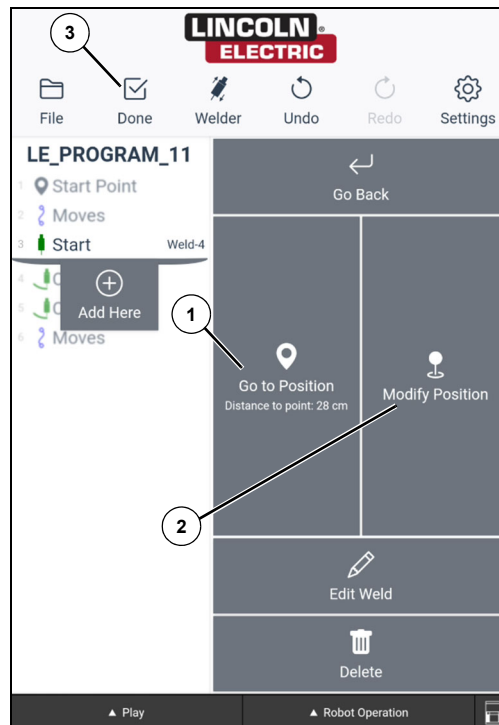

Figure 2-19

6. Select Done (3). This will write a new version of the program to the controller.
7. Move the robot to the program start position.
8. Run the program and verify the weld. Repeat steps 1–6 until the weld pattern is at the desired weld motion.

HOW TO RESOLVE UNVERIFIED MOVES

If the created program shows that there are unverified moves, there are three options to correct this:

- Resolve All Automatically (1)
- Resolve Selected Automatically (2)
- Re-Record Moves (3)

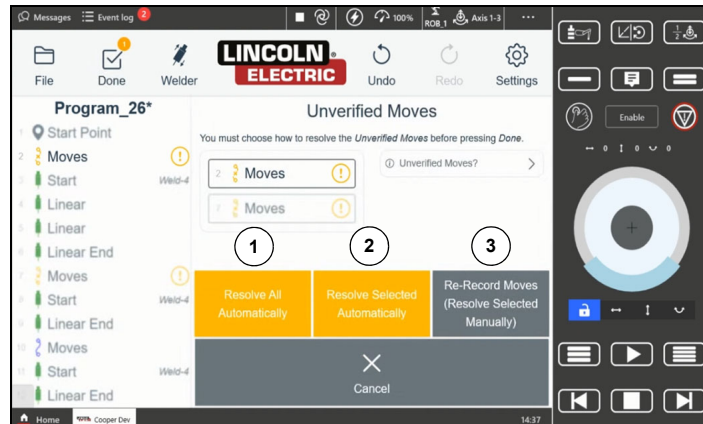

Figure 2-20

Resolve All Automatically:

For each of the unverified moves shown above that are present in the program, the Cooper App will insert a point in the program that is in a direct path to the next block. The operator should be mindful that the robot is free and clear of any obstacles.

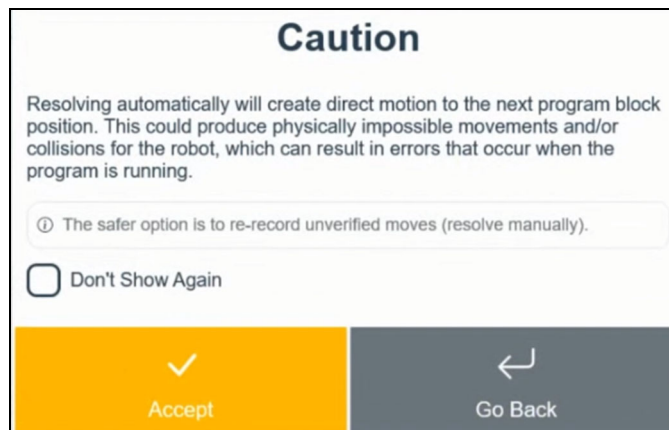

Figure 2-21

Resolve Selected Automatically:

For the selected unverified moves block, the Cooper App will insert a point in the selected program that is in a direct path to the next block. The operator should be mindful that the robot is free and clear of any obstacles.

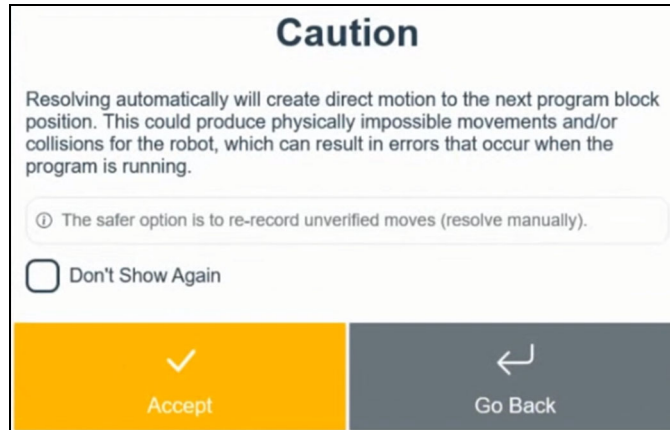

Figure 2-22

Re-Record Moves (manual resolution):

By selecting Re-Record Moves, the Cooper App will direct the operator to move to the last block in the program. Select Go to Last Program Block (4) and the robot will move to the last known location.

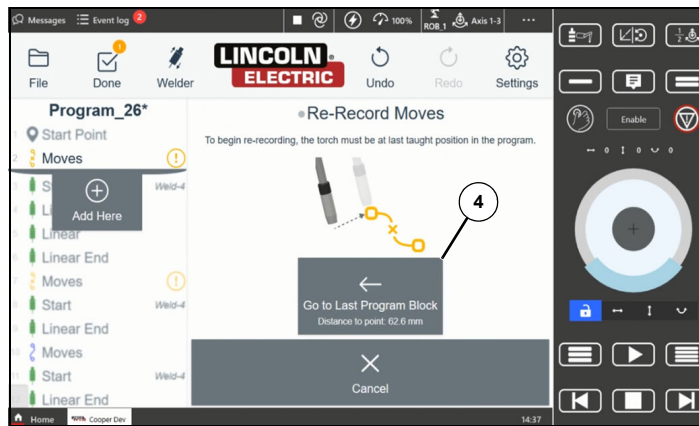

Figure 2-23

Move to the next program block. This can be done manually by pressing the blue button to unlock the robot and moving it by hand to the next program block or by selecting Go to Last Program Block (5) on the Cooper App. If the position is in the correct location, select Complete. If it is not in the correct location, select Restart and redo the motion.

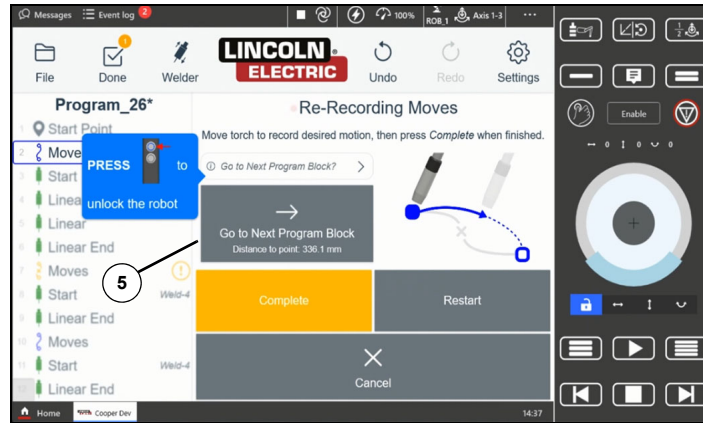

Figure 2-24

HOW TO SET MULTIPLE ARC STARTS

1. Select a program with intermediate points or create a new program.
2. To change the weld parameters being used, select the intermediate point and select Size: Weld (1).

The weld parameters are going to be the same as the weld start point. To change the weld parameters, go to Size and select the desired weld procedure you would like to switch to, see *Using Weld By Numbers* on page 2-4 for more information.

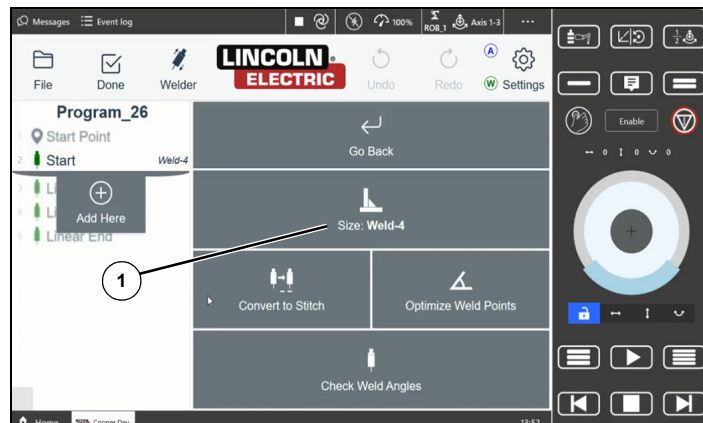

Figure 2-25

CREATING A CUSTOM WELD

1. Select the weld that is to be updated.
2. Select the Edit Weld icon (1). This will provide three options: Size: Weld, Optimize Weld Points and Weld Angle Tuner.

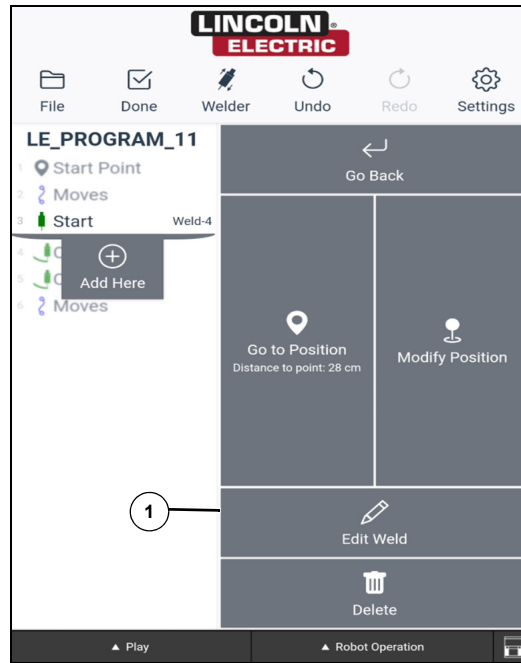

Figure 2-26

3. Select the Size: Weld icon (2). This will bring up the weld by numbers screen.

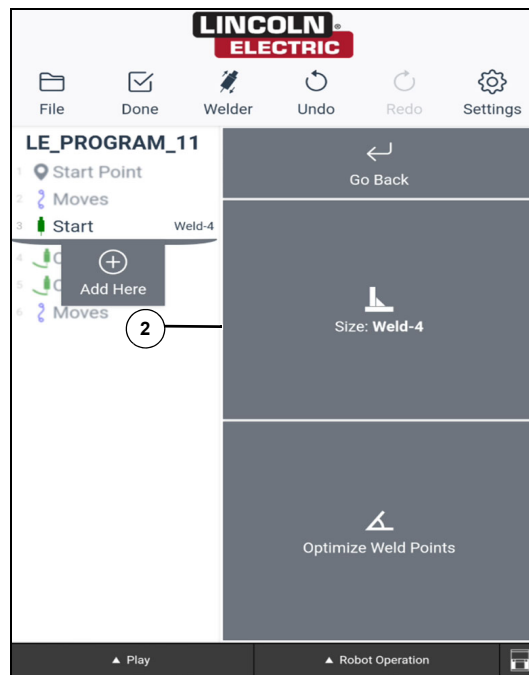

Figure 2-27

4. Select the weld by number to be customized and then select the copy icon. Insert the desired weld

name and select copy.

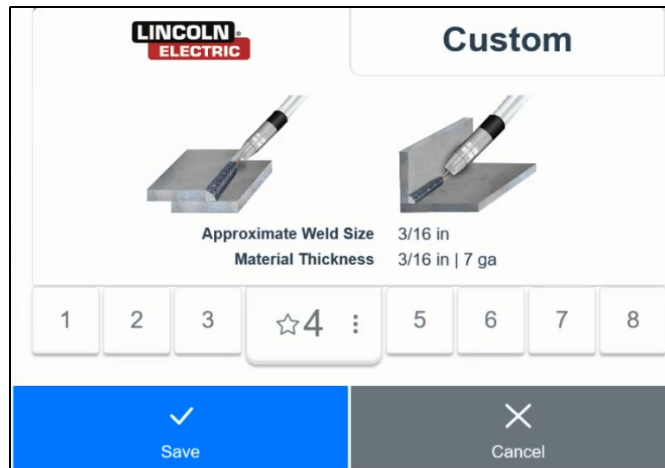

Figure 2-28

5. The Cooper App will display what weld procedure the weld was copied to. Then the Cooper App will list it under the custom weld schedule list.
6. Select the 3 dots (3) on the right side and select Edit.

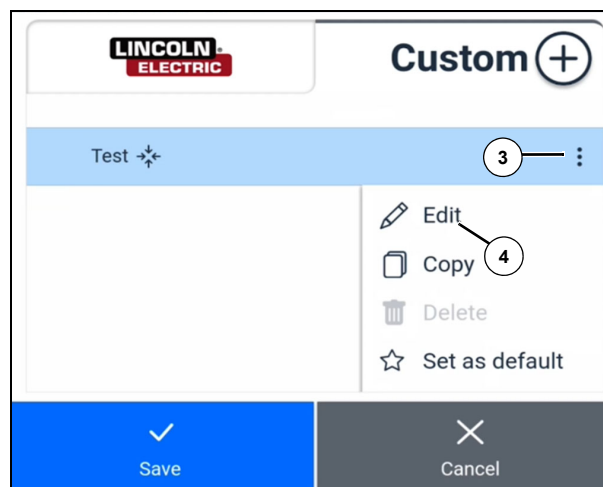

Figure 2-29

7. The simple weld editor will provide three editing options: Travel Speed (5), Wire Feed Speed (6), and Trim (7) Value. There is also an advanced tab that the operator can select, see *Advanced Editing Of Weld Data* . The Cooper App will redirect users to the Tuner App on GoFa systems.
8. Select the Save icon (8), to save any adjustments made to the weld parameters and close the Simple Weld Editor. By selecting OK. The operator will now see the updated weld name next to the weld point.

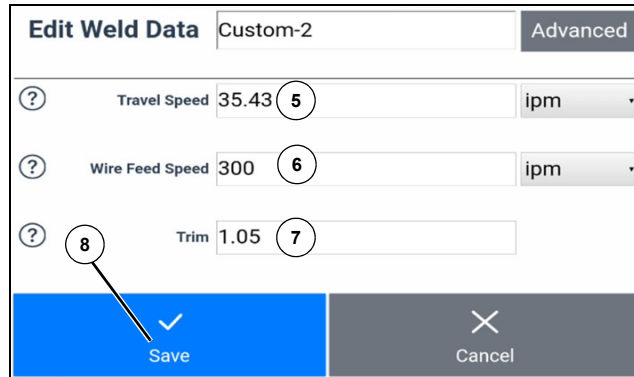

Figure 2-30

9. Select the Done icon to write the program.

IMPORTING CUSTOM WELDS

1. Open or create a program in the Cooper App.
2. Select the Size: Weld (1) to bring up the weld by numbers menu.

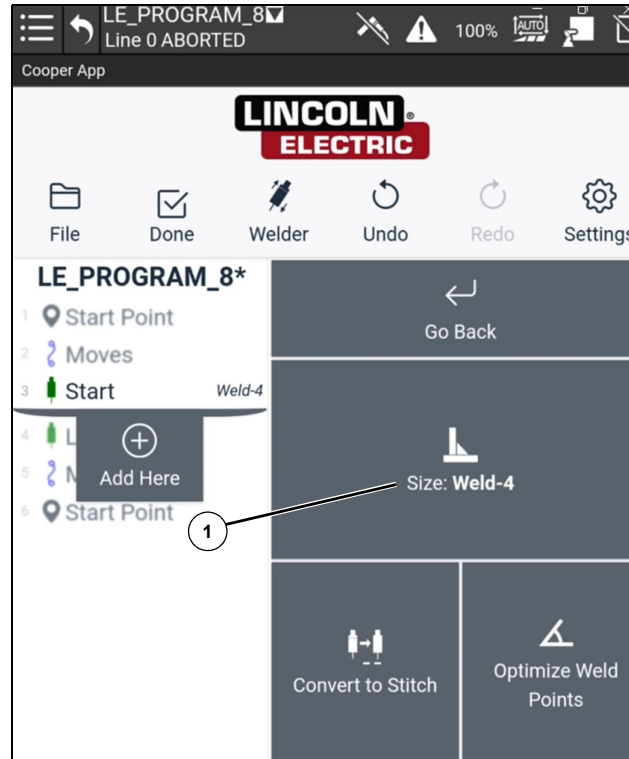

Figure 2-31

3. Select the Custom tab (2) and the + (plus) icon (3).

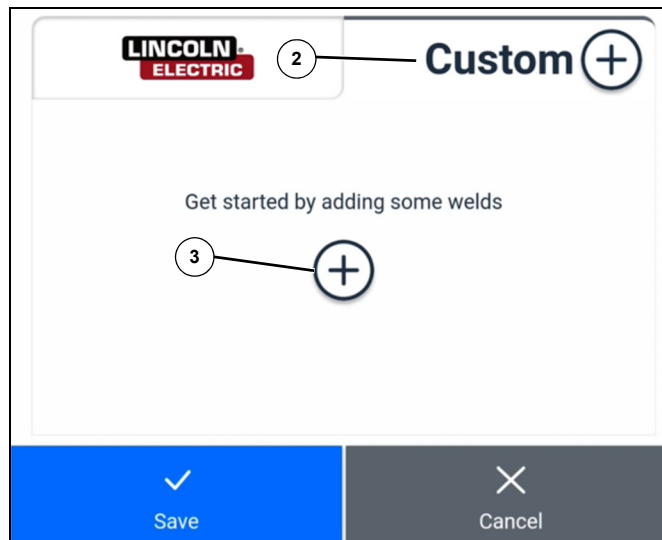

Figure 2-32

4. Type in the desired Name (4) for the custom weld. Insert the appropriate Weld Procedure number (5), Weld Schedule number (6), and Crater Fill Schedule (7) previously created outside of the Cooper App. Then select Import (8) to bring in the weld data.

Note: When importing weld procedure that has more than two weld schedules, a copy of the weld data will be made in a new weld procedure and stored as a format with two schedules.

Figure 2-33

5. The Cooper App will let the operator know that the import is complete, and if copied, which procedure number the weld data has been copied to.

Figure 2-34

ADVANCED EDITING OF WELD DATA

1. Create a linear weld, see *Programming A Linear Weld on page 2-1*.
2. Select the Start block (1).
3. Select the Size: Weld (2).

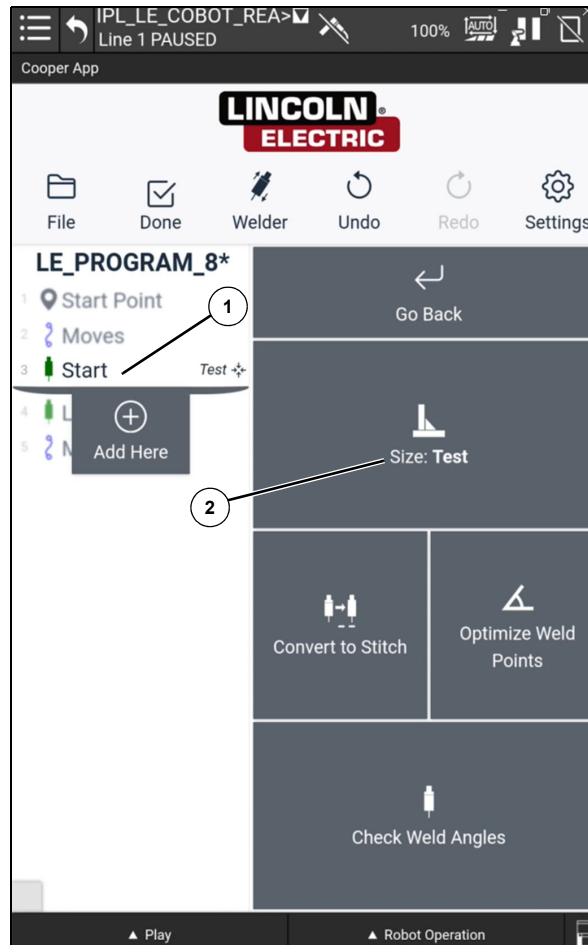

Figure 2-35

- Go to the Custom tab (3) and select the three dots (4), and then select Edit (5). This will bring the operator to the Simple Weld Editor.

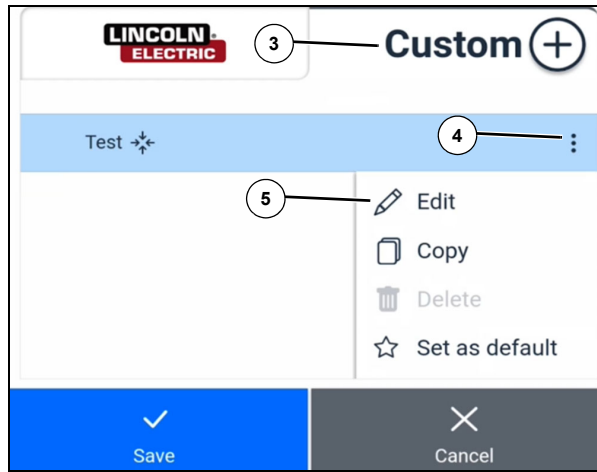

Figure 2-36

- To go to the Advanced Settings, select Advanced (6) to edit. This will bring up all of the advanced editing options available to the operator.

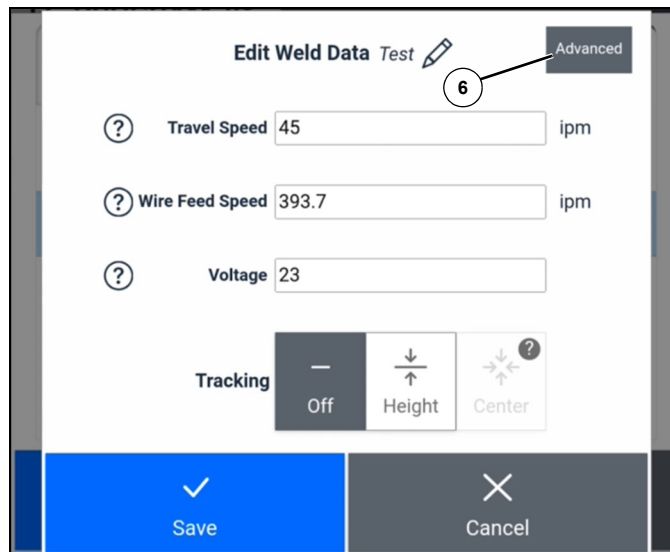

Figure 2-37

6. The operator can toggle the visibility icon (7) to either hide or show parameter descriptions. To change any parameters, click on the section to be changed and update the box with the appropriate number.

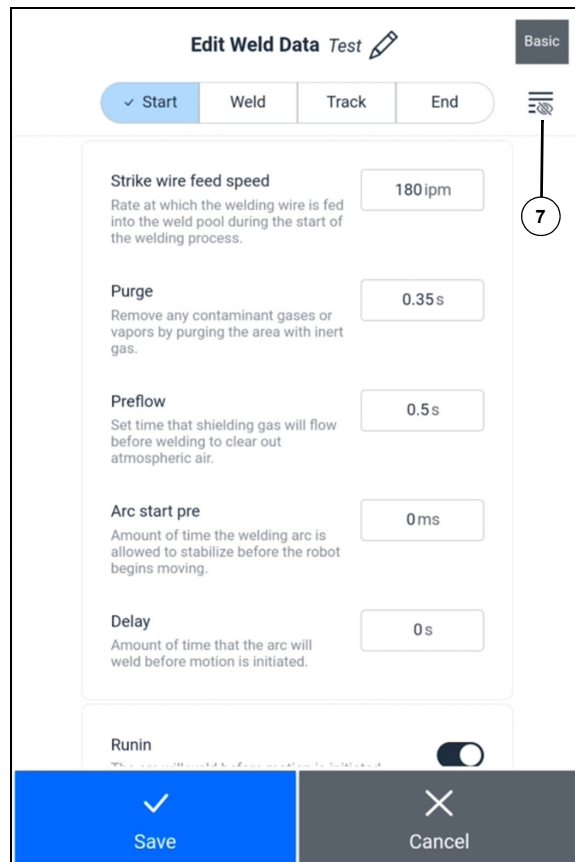

Figure 2-38

HOW TO SET CRATER FILL

1. See *Advanced Editing Of Weld Data* on page 2-19 for advanced editing.
2. Select the End tab (1) of the advanced Weld Data page.
3. Scroll down the page and enable Crater fill. Adjust the measurements as necessary.

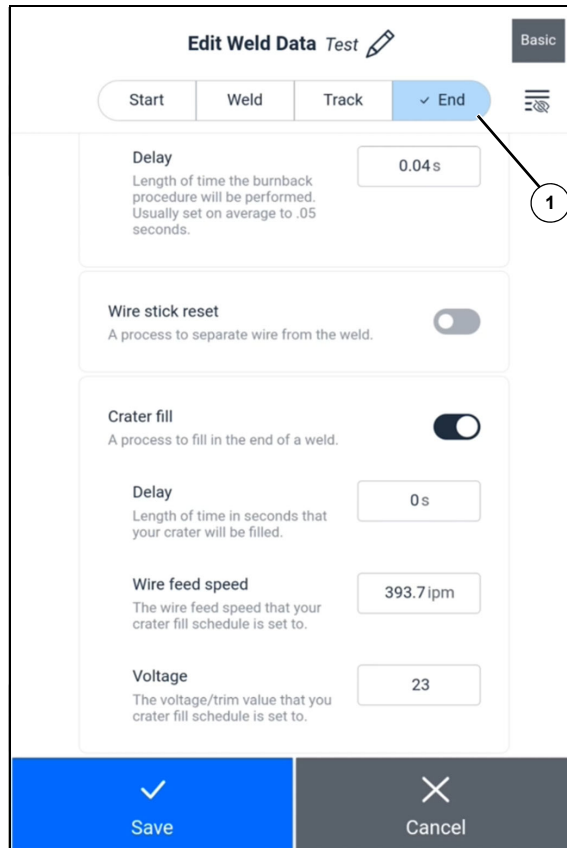

Figure 2-39

WELD ANGLE TUNER

1. To adjust the angle of the torch in the weld, go to the weld start point in the Cooper App.
2. Select the Check Weld Angles icon (1).

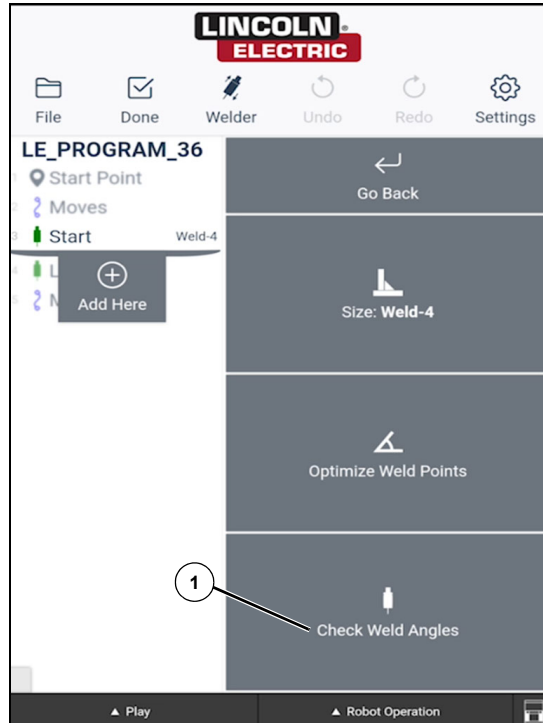

Figure 2-40

- The operator can adjust the Work Angle (2) (angle of the torch around the seam of the weld), Travel Angle (3) (degree of the torch as it moves along the weld), and Spin Torch (4) (rotation around the axis of the torch).
- Adjust the angles with micro adjustments by selecting the single arrow icons (5) or macro adjustments by selecting the multiple arrow icons (6).

Note: Micro adjustments are made in 1 degree increments and macro adjustments are made in 5 degree increments.

- Select the Update Weld Angles icon (7).

Note: Updating weld angles may cause an unverified motion. To correct this, please see *How To Resolve Unverified Moves* on page 2-11.

- Select the Done icon to complete the adjustment of angles in the program.

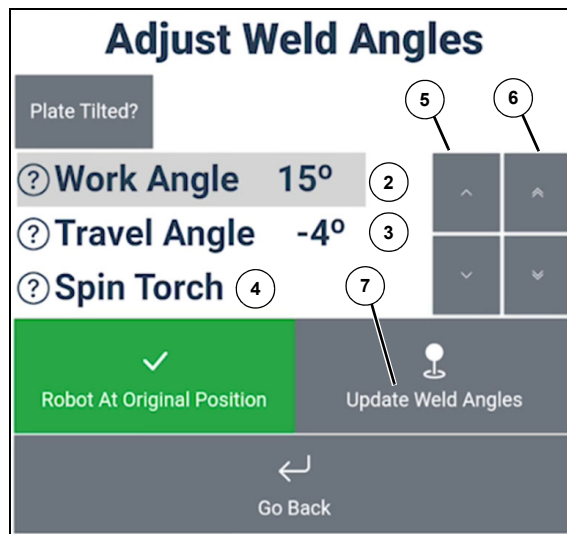

Figure 2-41

OPTIMIZING WELD POINTS

When creating a weld schedule, the operator may notice that the weld angle is not consistent throughout the welding process.

1. To correct this inconsistency, select Edit and then select the Weld Start block (1) of the weld to apply the consistent angle to.
2. Select the Edit Weld icon (2).

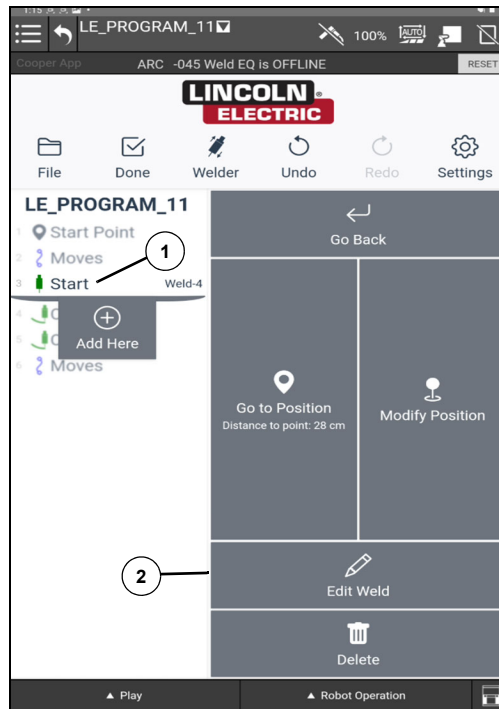

Figure 2-42

3. Select the Optimize Weld Points icon (3).

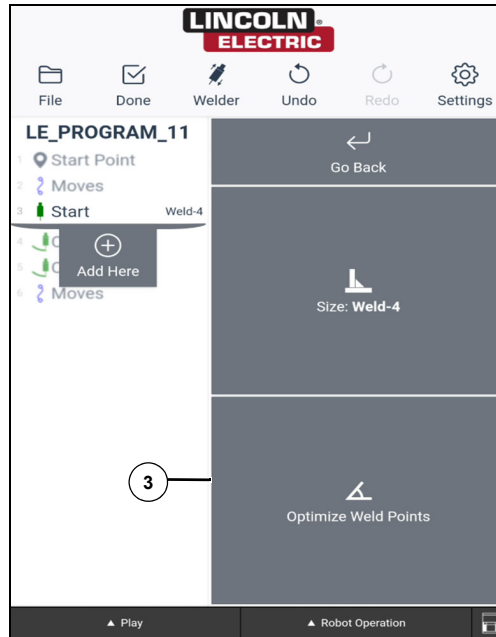

Figure 2-43

4. Select the apply icon (4). This will adjust the angles of the weld to match the starting point angle.

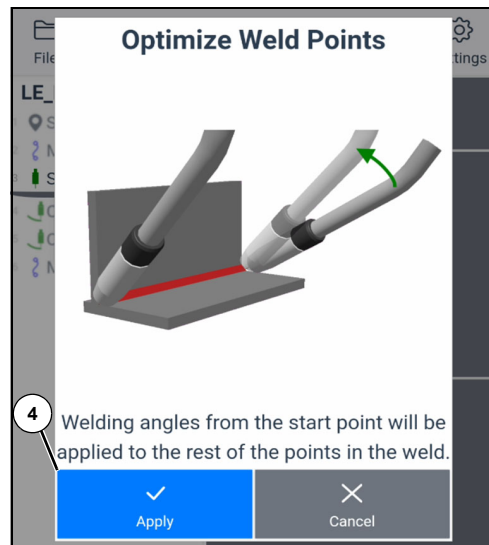

Figure 2-44

5. Select the Done icon to write the program. Run the program and verify that the weld angle is now consistent.

PROGRAMMING A PATTERN

1. To program a pattern, first the operator will need to define a home position that is up and out of the way of the part. Select Start Here icon (1).

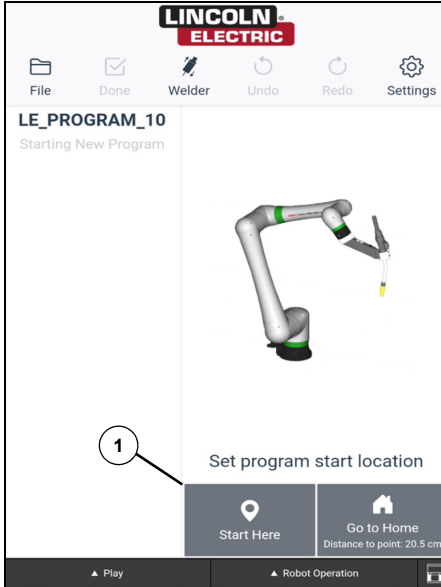

Figure 2-45

2. Unlock the robot by pushing the blue button (2) on the robot.
3. Move the robot above where the weld start should be.
4. Instead of programming the weld, select the More Choices icon (3).

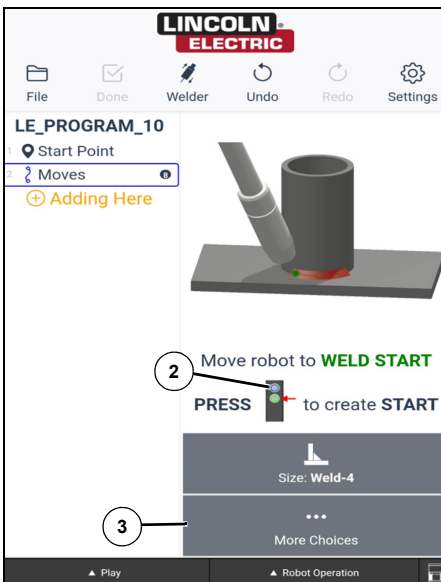

Figure 2-46

5. Select the Add Pattern Start icon (4).

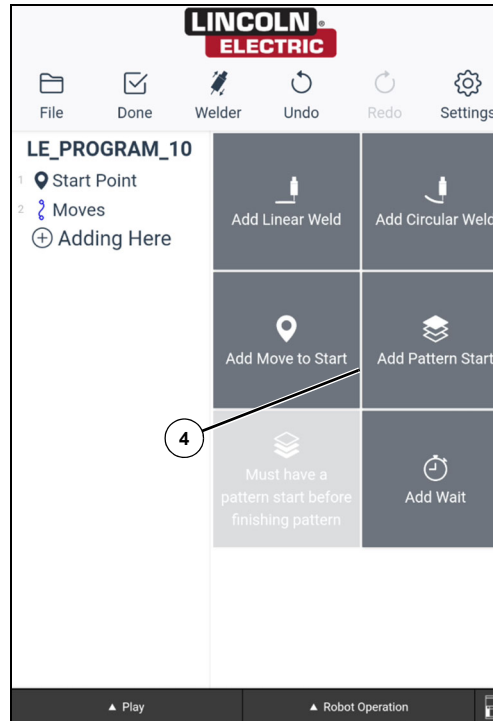

Figure 2-47

Note: The pattern start point is the approach into the pattern. The pattern start point should be up and out of the way, clear of any obstacles.

6. The Cooper App will ask the operator to define the pattern start point. To teach the pattern start point, press the green button. The operator is now able to teach the weld.

7. Select the Add Linear Weld icon (5).

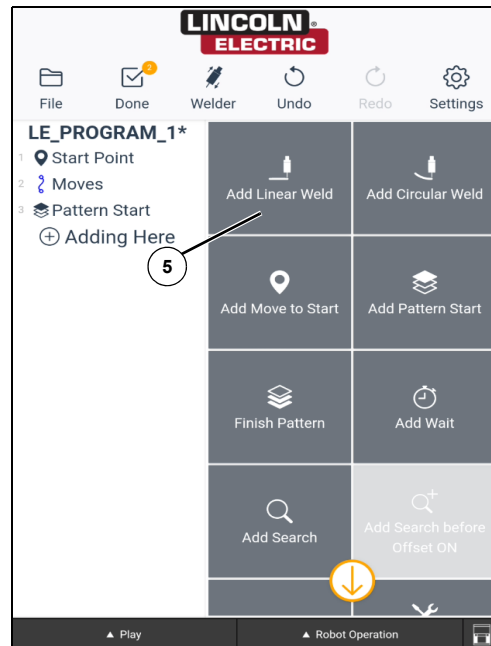

Figure 2-48

8. Unlock the robot and move the robot into the weld start point. To teach, press the green button.
9. Move the robot along the part. Complete a long press of the green button to teach the weld end.
10. Move the robot up and out of the way of the part.
11. Instead of continuing to teach more welds, select the More Choices icon (6).

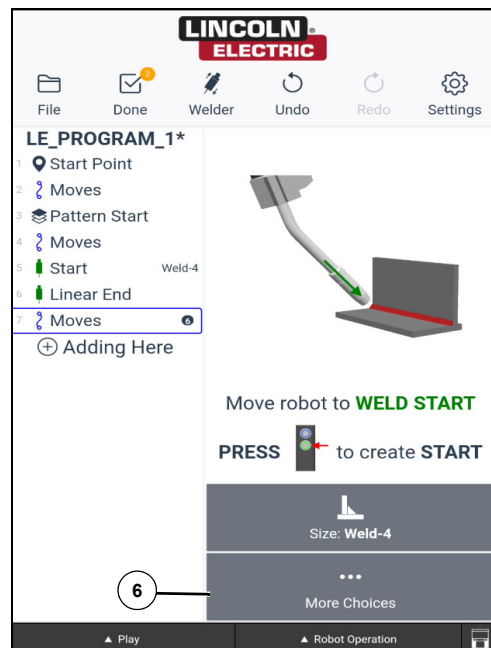

Figure 2-49

12. Select the Finish Pattern icon (7).

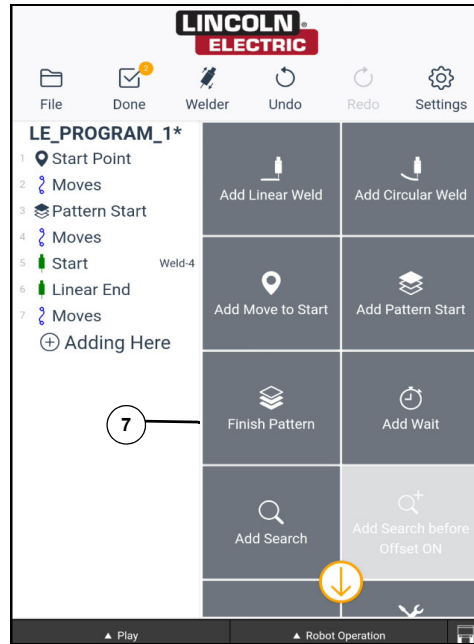

Figure 2-50

13. The Cooper App will ask the operator to teach the pattern end. This will be the departure point from the pattern, a position up and away from any parts. To teach this, press the green button.
14. The Cooper App will now instruct the operator to teach the part points. these will be equivalent datums on the first and last part in the pattern.
15. Unlock the robot and move the robot to the first part point. To record the point, press the green button.
16. Move the robot to the last part. To record the part, press the green button.
17. The Cooper App will now ask to define the Pattern Count (8). Insert the correct Pattern Count and select the Confirm icon (9).

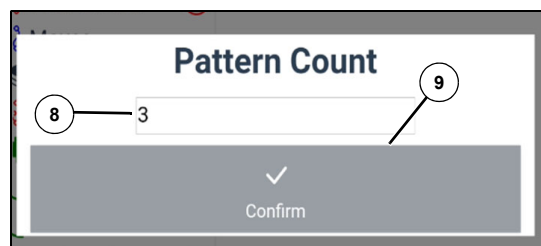

Figure 2-51

18. Teaching the pattern is now complete. Move the robot up and away from the parts and select the Done icon. The Cooper App will now write the program to the controller. To run the program, select the green play button.

PROGRAM BATCHER—SCHEDULER

The Cooper App has the ability to run multiple programs in any order back-to-back that fits the operator's needs. This is called batching.

1. To schedule batching, select the File icon (1) and then select Production Mode (2).

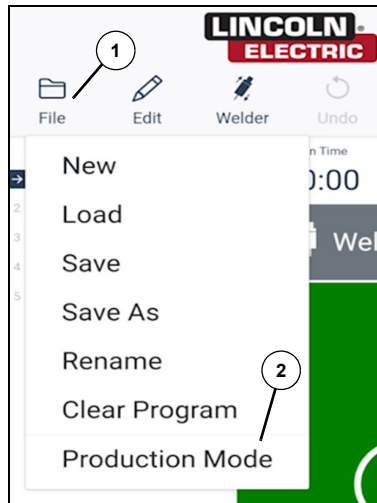

Figure 2-52

2. Select the Add icon (3) to add the desired programs into the scheduler.

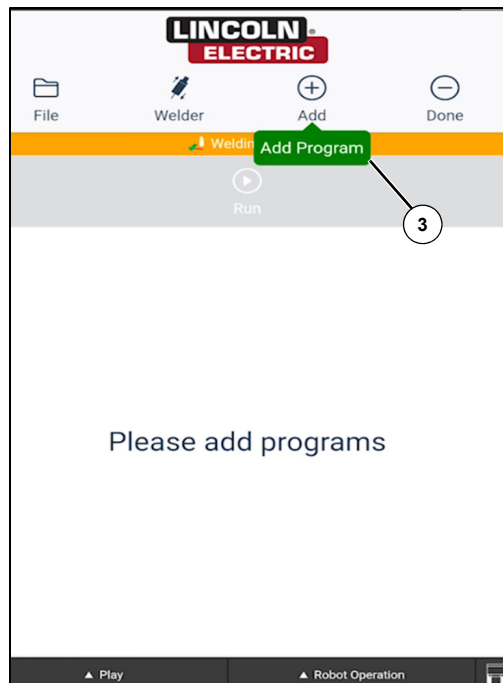

Figure 2-53

3. Select the appropriate programs to be added and then select the Add icon (5).



Figure 2-54

4. Queue the programs in any order by selecting or deselecting the program.
5. Select the Run icon (6). The welder will now run through the queued programs until the operator selects the pause icon or there is no longer any programs ready in the queue.

Note: The operator can reorder the program list as the welder is running.

6. Select File (7) and Create Mode to return to the editing mode and dry run mode.

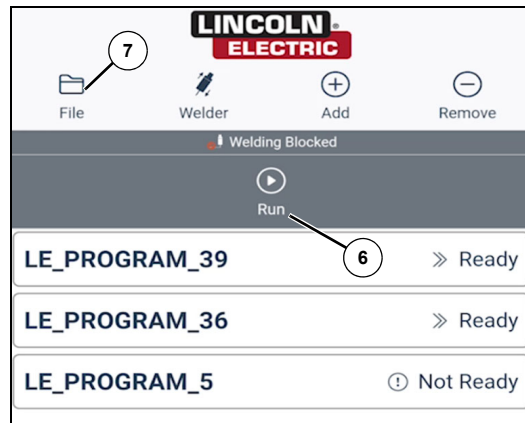

Figure 2-55

HOW TO USE TACK MODE

1. From the program screen go into the file menu and select Tack Mode.
2. The program will present a Tack Overview (1). The operator can click through or close this option.

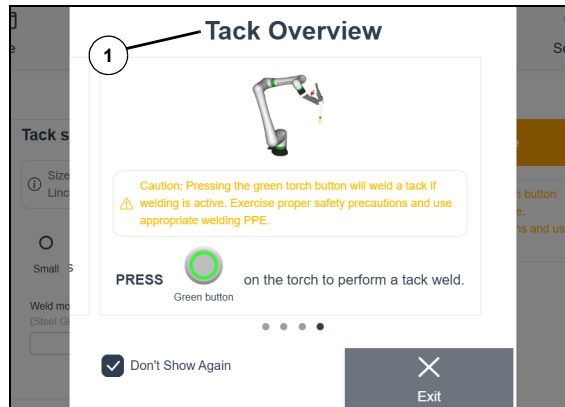

Figure 2-56

3. In the tack menu, the operator can select the appropriate Tack weld size (2) based off their currently loaded Weld Data or create a Custom tack size (3).

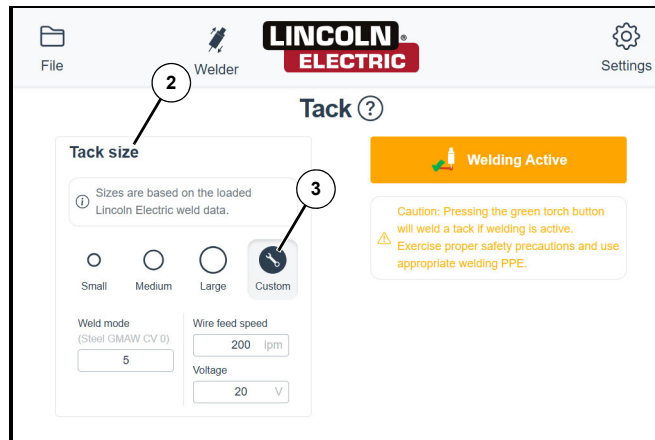

Figure 2-57

WARNING

Warning: Wear proper personal protective equipment (PPE) when operating the robot with the welder active. Failure to wear proper PPE will result in serious injury or death.

4. Active the welder.
5. Unlock the robot by pressing the blue button, and move the robot into the correct welding position.
6. Press the green button to perform a tack weld.
7. Once tack has been completed, move the robot out of the way of the part.

- Once all tack weld have been made, select File (4) and then select Create Mode (5). This will bring the operator back into the program editor.

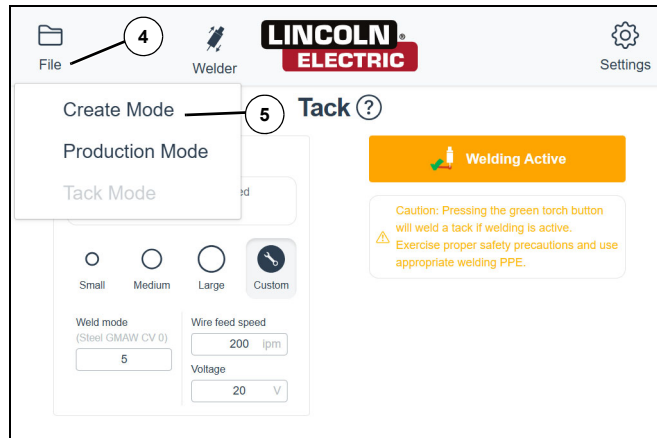

Figure 2-58

Section 3**USER INTERFACE–ADVANCED WELD FEATURES****PROGRAMMING A STITCH WELD**

To program a stitch weld, first program a linear or circular weld. See *Programming A Linear Weld* on page 2-1 or see *Programming a Circular Weld* on page 2-2.

1. Select the weld to be edited, and press the Edit Weld icon (1).

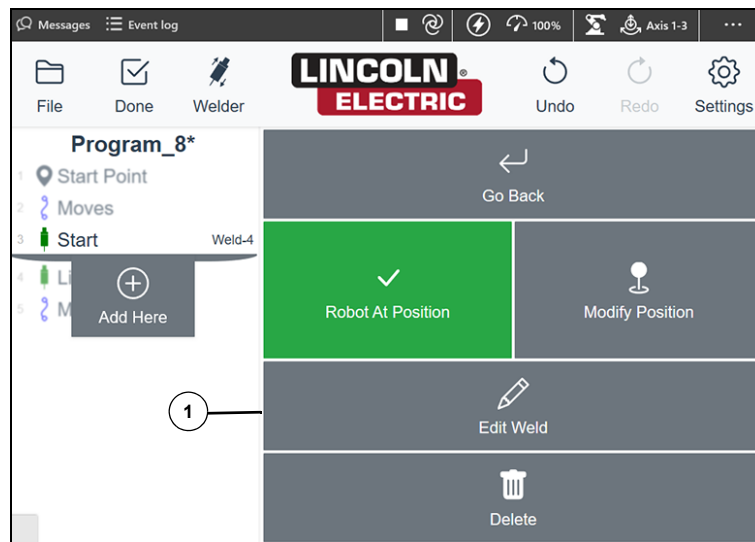

Figure 3-1

2. Select the Convert to Stitch icon (2).

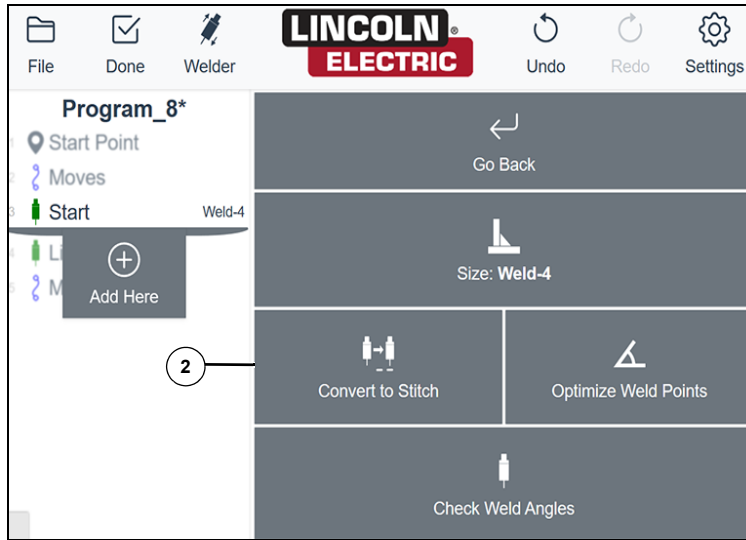

Figure 3-2

3. Here the operator will be able to adjust the Stitch Length (3) and Center to Center (4) to the desired measurements.

4. Select the Apply icon (5).

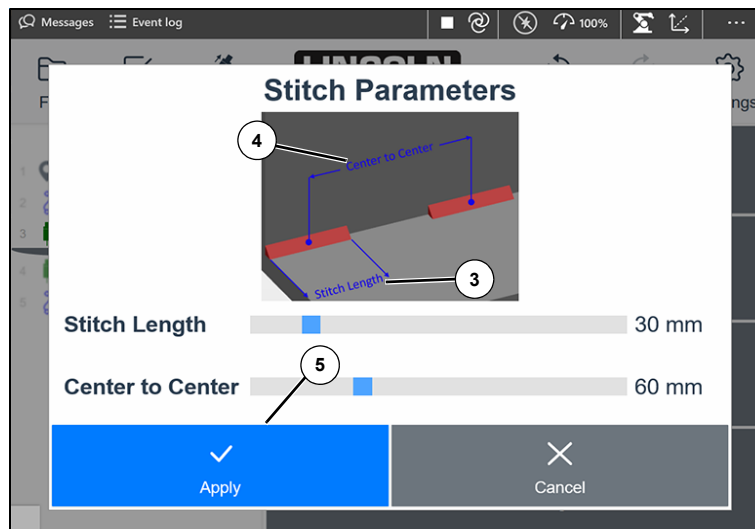

Figure 3-3

5. Select the Done icon to write the program.

SEARCH

1. Define the start location and select the More Choices icon (1).

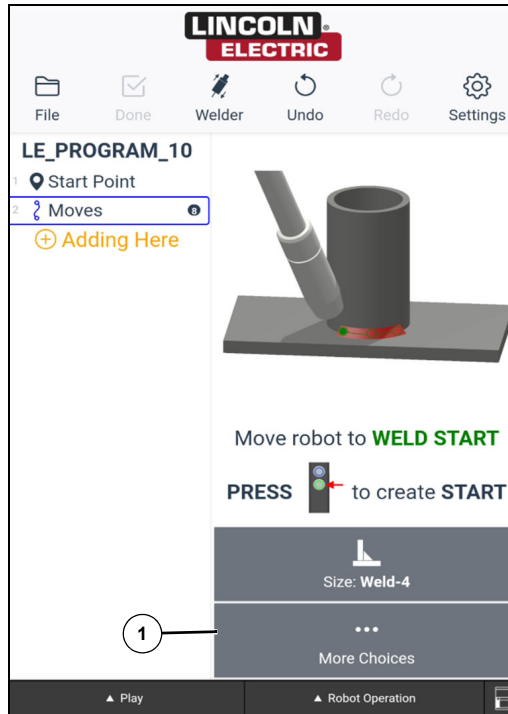

Figure 3-4

2. Select the Add Search icon (2).

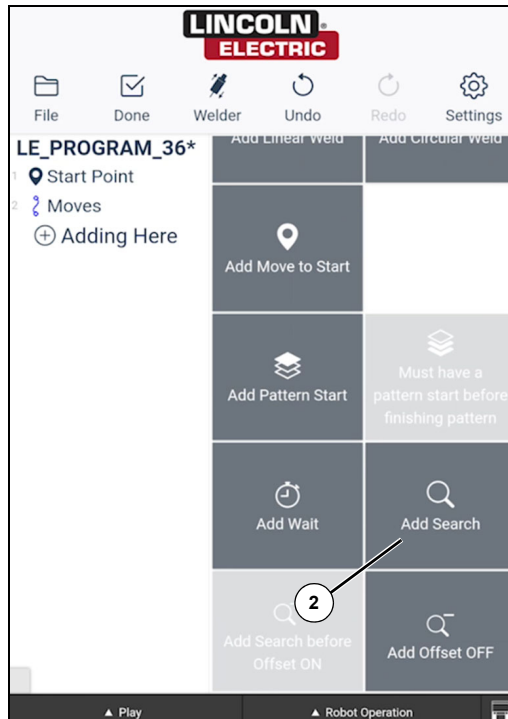

Figure 3-5

Note: The robot will search two times the distance from the search point start to the part.

Note: Ensure there is enough stick out on the wire to make contact with the part.

3. Move the robot to point on part that robot will touch during searching.
4. Lock out the robot joints in the Robot Operation tab (3) so the robot will only move in one direction.

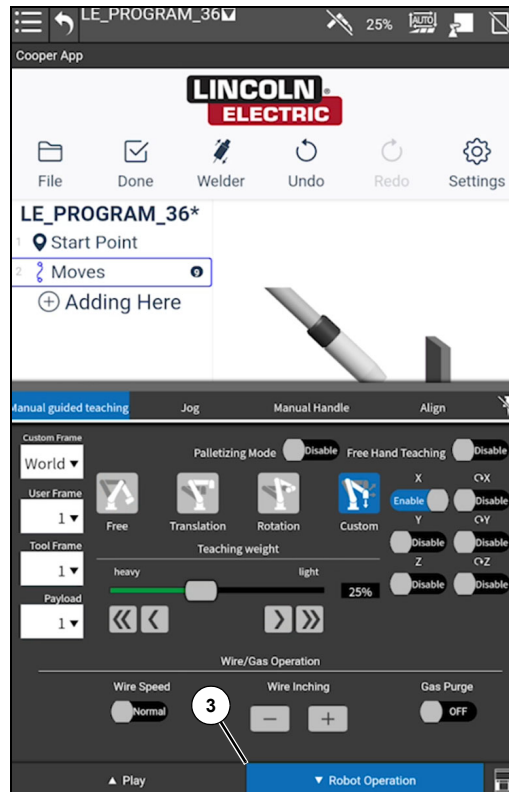

Figure 3-6

5. Move robot away from the part to the search start point.
6. Record the first point by pressing the green button.
7. Move the robot to the search end point and press the green button to record the search end point. The search end point is the point touching the part.

⚠ WARNING

Warning: Part Search process applies current to weld wire. Wear proper personal protective equipment (PPE) when operating the robot with the welder active. Failure to wear proper PPE will result in serious injury or death.

8. Ensure the welder is on.
9. Select the Go to Search Start icon (4).
10. When the robot reaches the Search Start position, select the Calibrate Search icon (5).

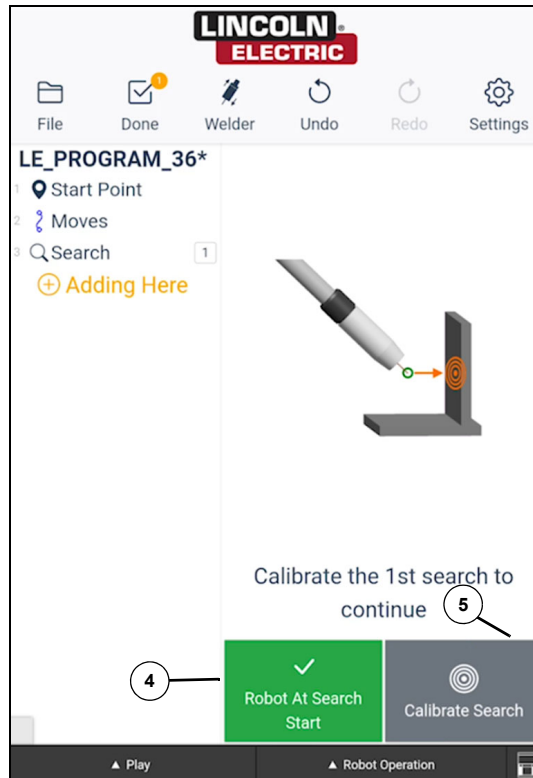

Figure 3-7

11. The operator can now add a different search in another dimension or continue teaching the program. To continue teaching the program, select more choices icon (6).

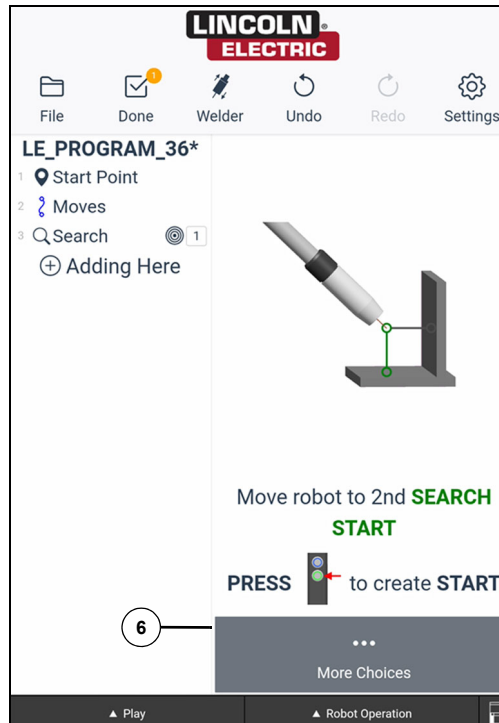

Figure 3-8

Note: Adding an offset to the search group will add the previously created search to the next weld being created.

12. The operator will now be presented with an option to add an offset for the search group. Select the Yes icon (7) to use the offset found in the search or No icon (8) to ignore this offset.



Figure 3-9

13. Unlock the axis on the robot. In the Robot Operations Tab, change the Manual Guided Teaching (9) mode back to Free (10).

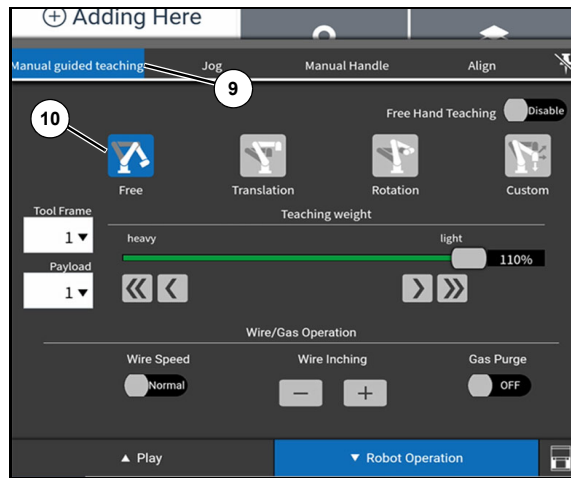

Figure 3-10

14. Program a weld, see *Programming A Linear Weld on page 2-1* or see *Programming a Circular Weld on page 2-2*.
15. Select the More Choices icon and then select Add Offset OFF (11).

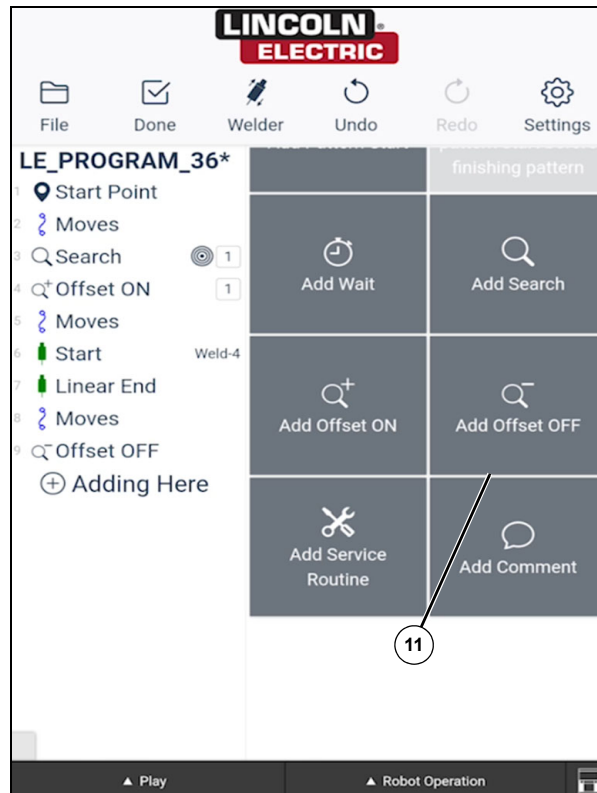

Figure 3-11

16. Select the Done icon and run the program.

THRU-ARC™ TRACKING

1. To track the weld, go through the weld by numbers process. For more information, see *Using Weld By Numbers* on page 2-4 and see *Creating a Custom Weld* on page 2-14.
2. Select the 3 dots on the right side of the weld and then select the edit icon (1) on the Custom list page.

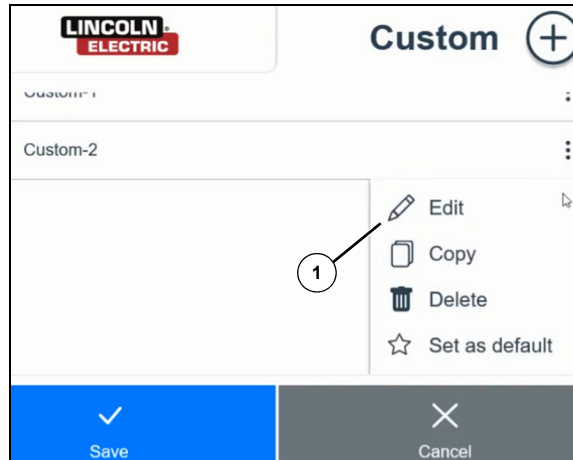

Figure 3-12

3. Here the operator will be presented with three tracking options: Off (2), Center (3), and Height (4). Select the appropriate tracking.

Note: Centerline tracking is only available on weld schedules that use a weave.

4. Select the Save icon (5). The program will now be updated with tracking enabled.

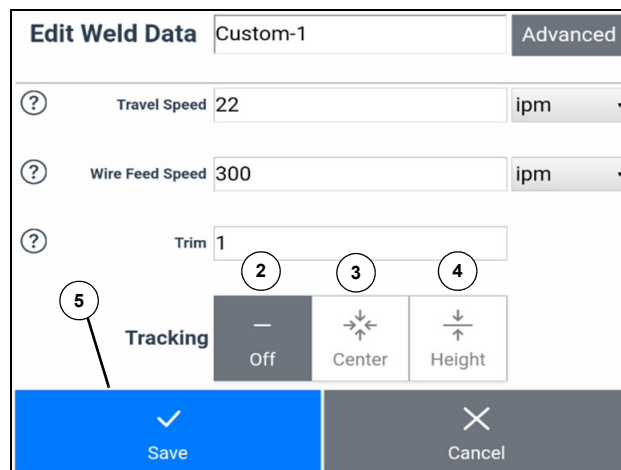

Figure 3-13

MULTI-PASS WELDING

WARNING

Warning: Wear proper personal protective equipment (PPE) when operating the robot with the welder active. Failure to wear proper PPE will result in serious injury or death.

1. To program a multi-pass weld, first program a linear weld. See *Programming A Linear Weld* on page 2-1 and weld the part.
2. After the weld is complete, go into edit mode and select the Add Pass icon (1). This will provide a selection for the root weld.

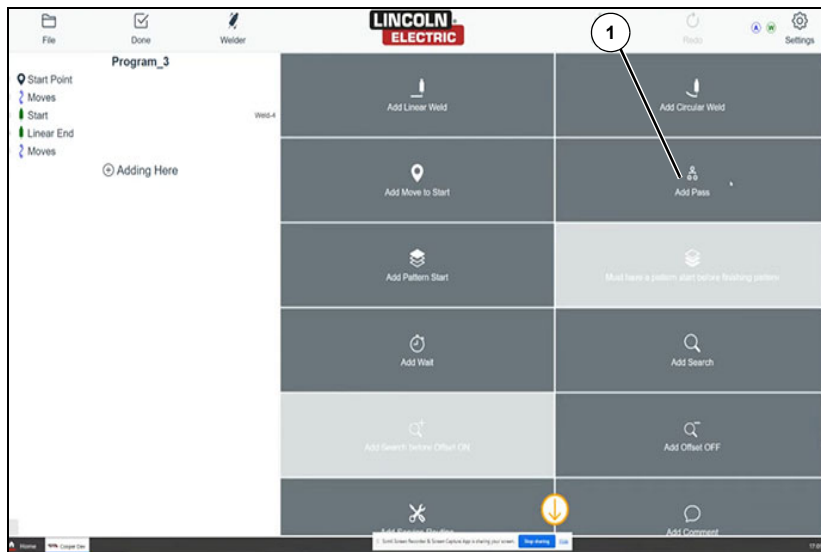

Figure 3-14

3. Select the weld to have a multi-pass applied.

Note: The operator will have the option to press the Go to Weld Start icon on any of the available root passes to determine the correct root pass.

4. Once the correct root pass has been selected, press the Confirm icon (2). Now the operator will be able to teach the next pass. The pass can be taught to weld in either direction by moving the robot to the side of the weld to be started on.

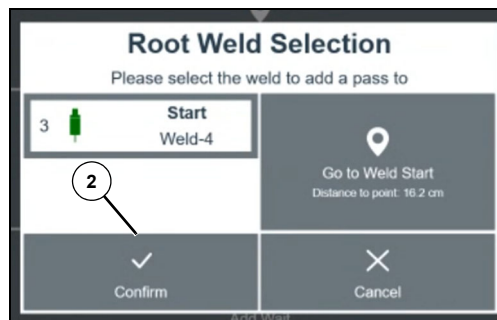

Figure 3-15

5. Unlock the robot and move the robot to the start position; off of the root seam pass.

6. Teach the pass start by pressing the green button on the robot.

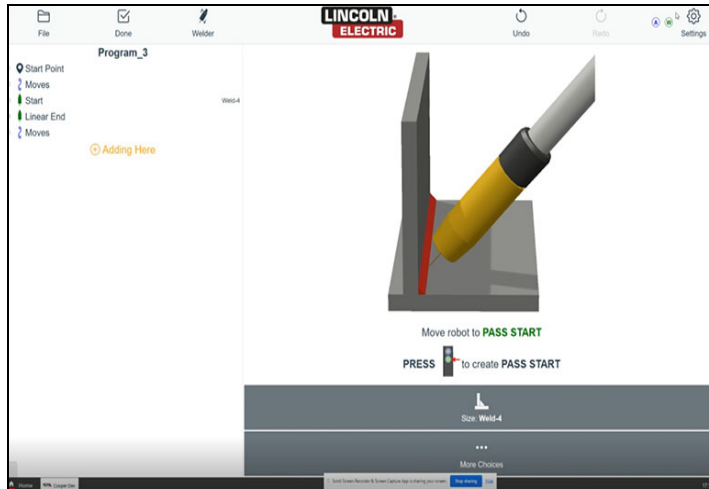

Figure 3-16

7. Move the robot to the end of the weld; off of the root seam pass. Press and hold the green button to record the pass end location.

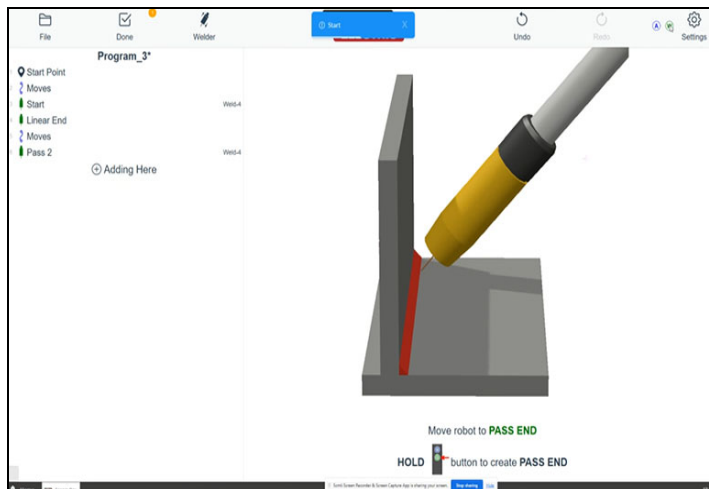

Figure 3-17

8. Move the robot up and out of the way of the part. Pass 2 has now been completed.
9. Select the Done icon and weld the pass 2.
10. Repeat steps 2–9 for any additional passes.

CREATE A MULTIPASS TEMPLATE

Note: A multipass template is used in a case where a multipass weld has been created and the stacking pattern and offsets are to be reused.

1. Go into edit mode and select the insert location (1). The insert location is a point that is below the root weld that has passes associated with it.
2. Select the Create Multipass Template icon (2).

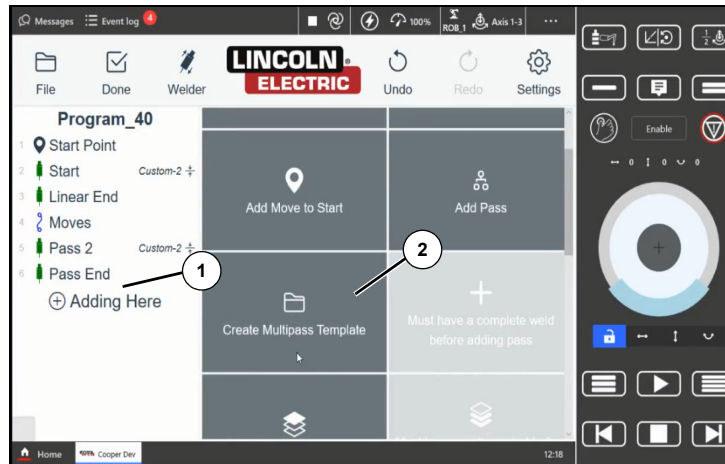

Figure 3-18

Note: The Cooper App will provide a selection of the available root welds with the associated passes that the user can select to create a template from.

3. Select the desired root weld then go to the Weld Start position (3) and select Confirm (4).

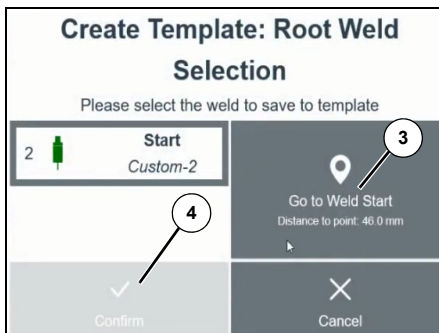

Figure 3-19

- The Cooper App will now prompt the user to create a name for the template.
- Select the appropriate Weld Shape (5) then select the Confirm icon (6).

Note: This is not an inclusive list. Select the shape that matches the welding shape the closest.

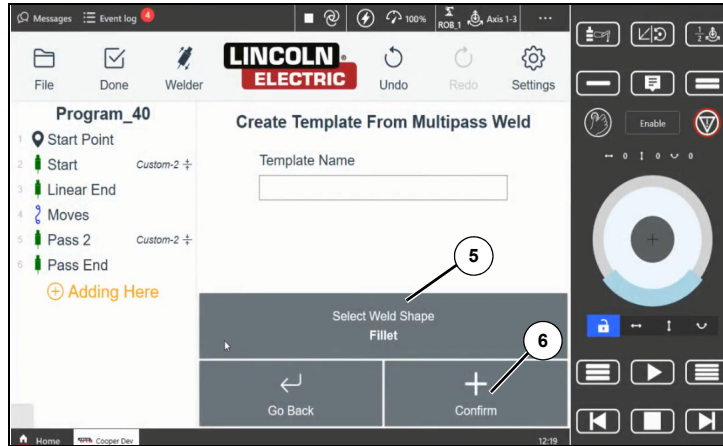

Figure 3-20

- Move the robot so the tip of the wire is touching the edge of the base plate. Press the green button or select the Update icon (7) to record this point.

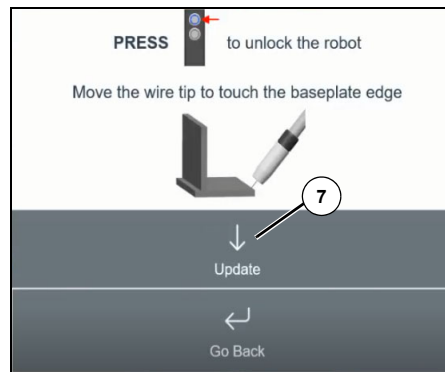

Figure 3-21

- The Cooper App will now inform the operator that the template is now saved to disk. The template can now be applied to any other multipass welds.

APPLYING A MULTIPASS TEMPLATE

1. In order to apply a multipass, template, at least one template must have previously been created. If none have been created, create a multipass template, see *Create A Multipass Template on page 3-11*.
2. Go into Edit Mode and teach a root weld. Ensure the insert location is below the root weld and select the Add Passes From Template icon (1). This will give the operator an option to select the desired root weld.

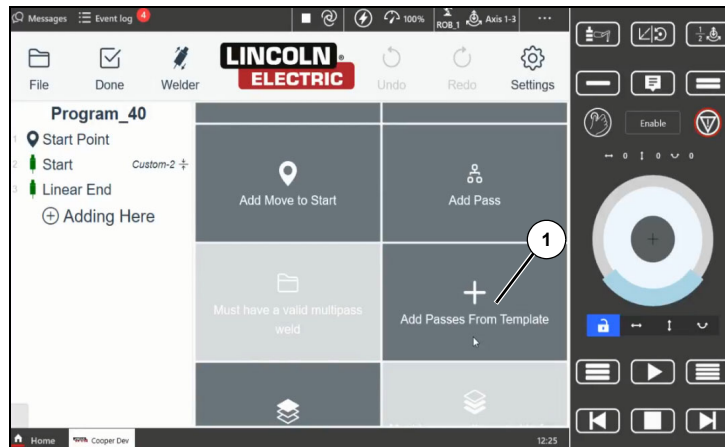

Figure 3-22

3. Go to the weld start of the root weld and select Confirm. The Cooper App will now provide the operator with a list of templates (2) to choose from.
4. Select the desired template and select the Next icon (3).

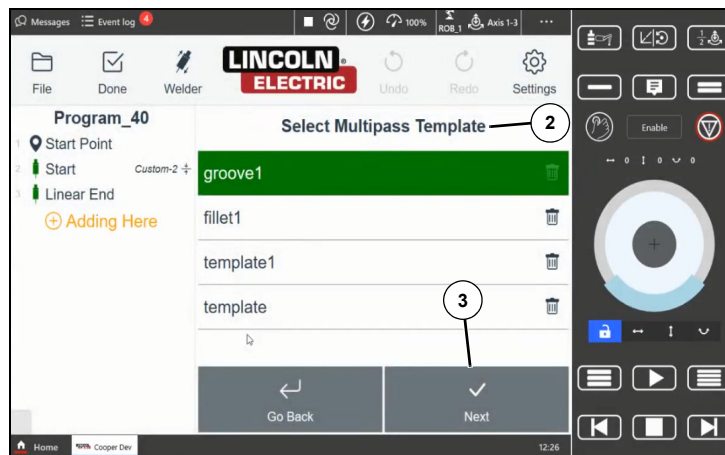

Figure 3-23

5. Specify the offset effect for the start and end edges of the passes (4) then select the Next icon (5).
- Note:** The options for the edge offsets are to leave the passes as they were taught in the template, to create a flush effect where all passes have the same elongation, or a cascade effect. These can be selected individually for the start and the end of the weld.

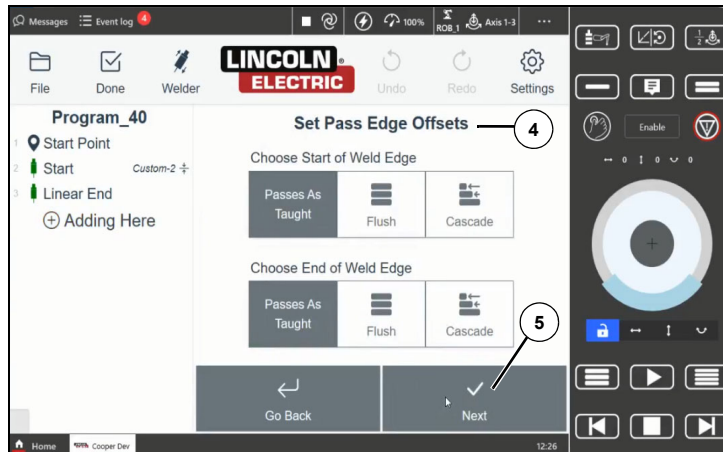

Figure 3-24

6. Teach the base plate of the root weld. Unlock the robot and move the wire so that the wire tip touches the edge of the base plate and press the green button or select the Update icon (6).

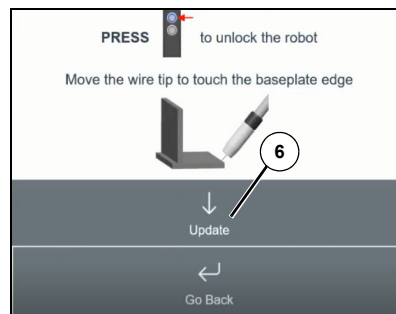

Figure 3-25

7. The Cooper App will now show the passes have been added from the template.
8. Move the robot up and out of the way of the part. The operator can now run the program with the passes that have been applied from the template.

Section 4**PROGRAMMING WITH EXTERNAL AXES****HOW TO JOG EXTERNAL WITH AXES**

At the top of the program screen, select Devices. This will bring up all available device options. The operator is able to resize the menu to make it bigger, smaller, move the screen position, or pin (1) it in a certain location. The middle three dots (2) will give the user more options to simplify all controls, expand all controls, and set device visibility.

The operator can set the max speed (3) to jog a given axis at. The default speed is 50%.

To jog an axis, the operator can use the slider (4) to jog left or right.

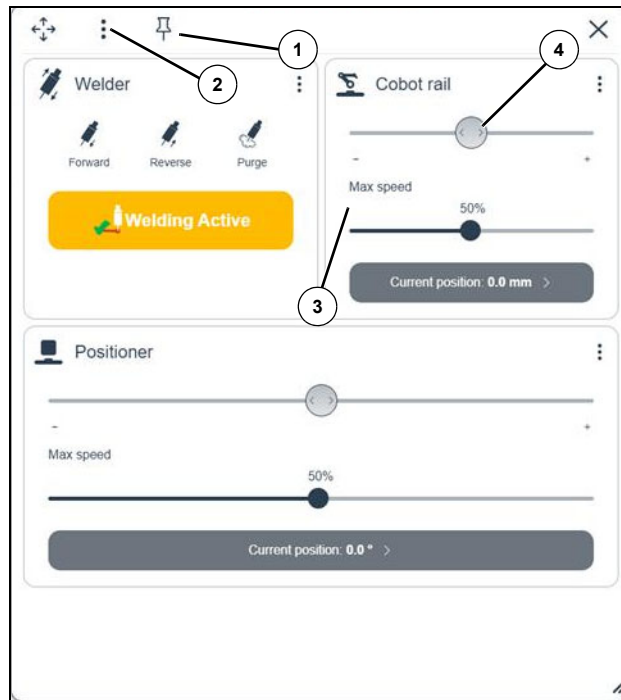

Figure 4-1

Programming with External Axes

The operator can also select Current position (5) and enter the desired location to jog to. Selecting Go to Position (6) will automatically jog the Cobot to that position.

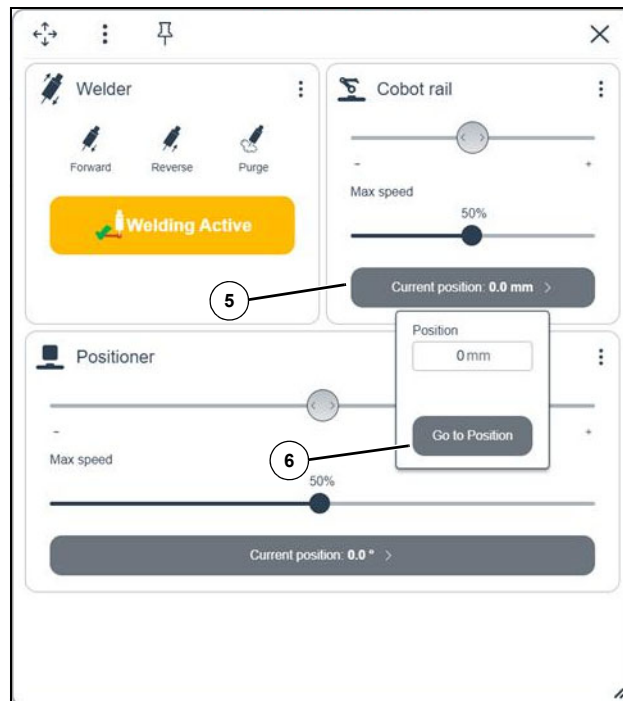

Figure 4-2

HOW TO TEACH A PROGRAM WITH A RAIL

Note: To teach this program is the same method as any other standard Cooper App program.

1. To start, define to the home position by moving the Cobot up and out of the way, free from any parts or obstructions. Select Start Here (1).

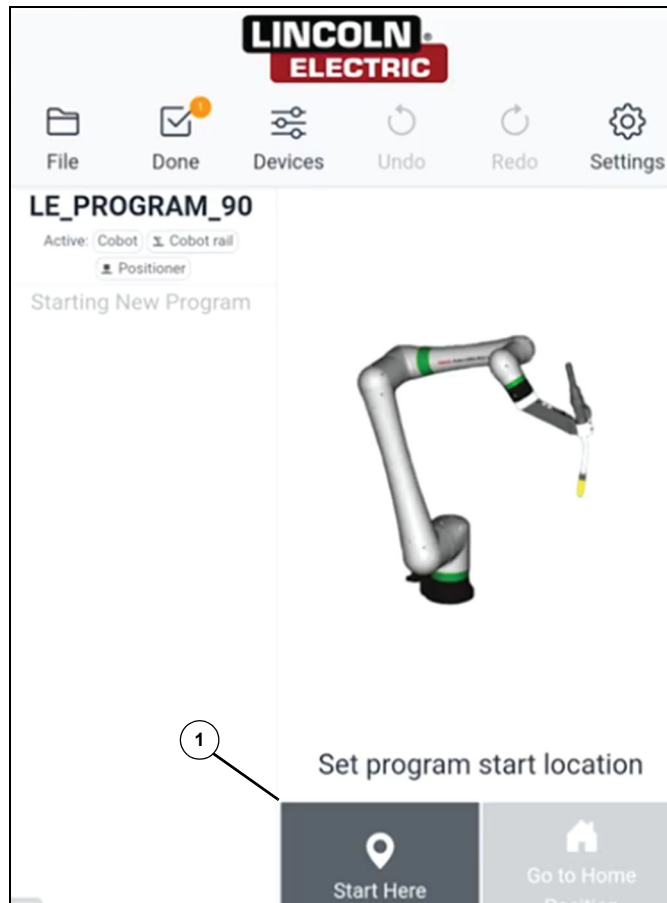

Figure 4-3

2. Press the blue button to unlock the robot. Move the robot by hand to the weld start position.

3. If the Cobot needs to be moved along the rail to reach the weld start, select Devices (2) and use the slider (3) to move the Cobot to the desired location.

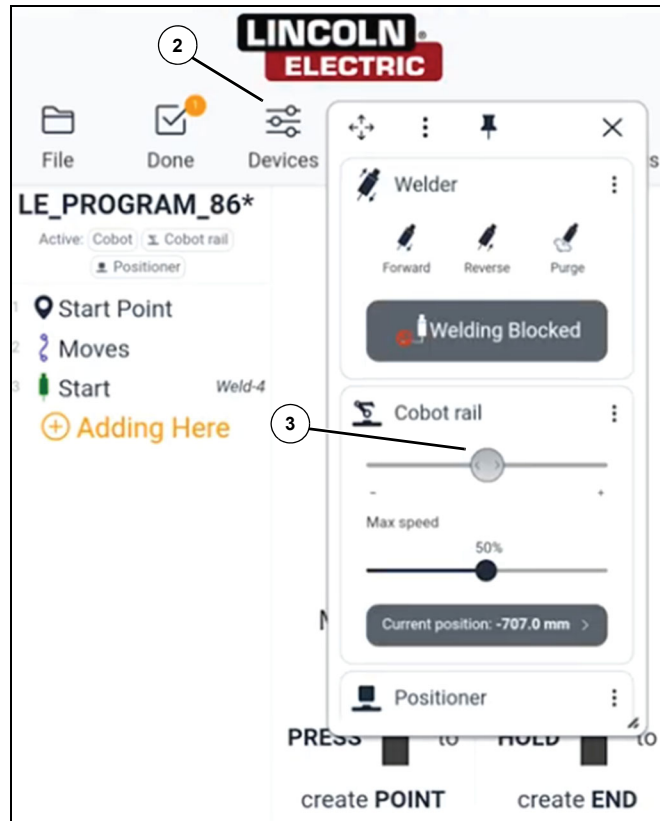

Figure 4-4

4. Once the Cobot is at the desired weld start location, press the green button to create start.
5. Move the Cobot to the desired end location. If the Cobot needs to be relocated along the rail, follow step 3 to jog the Cobot into position.
6. Hold the green button to record the end point. Unlock the robot and move the robot up and out of the way of the part. Select Done to complete the program.

HOW TO TEACH A PROGRAM WITH POSITIONER

1. Go to the file menu and select new.

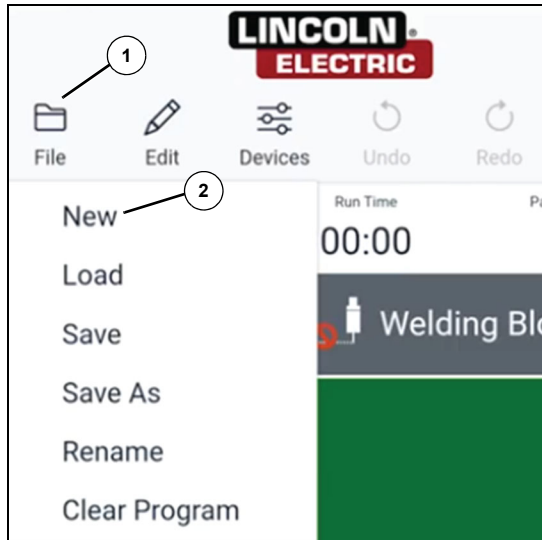

Figure 4-5

2. Ensure that Positioner (3) is checked.

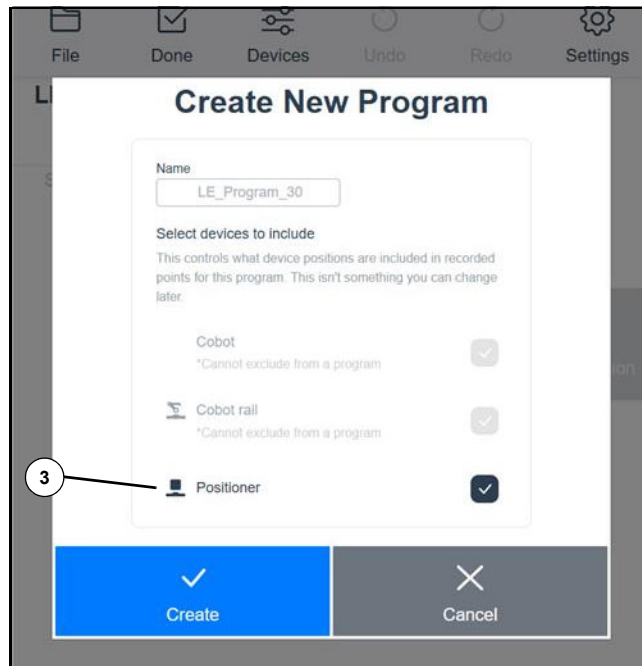

Figure 4-6

3. To start, define to the home position by moving the cobot up and out of the way, free from any parts or obstructions. Select Start Here (4).

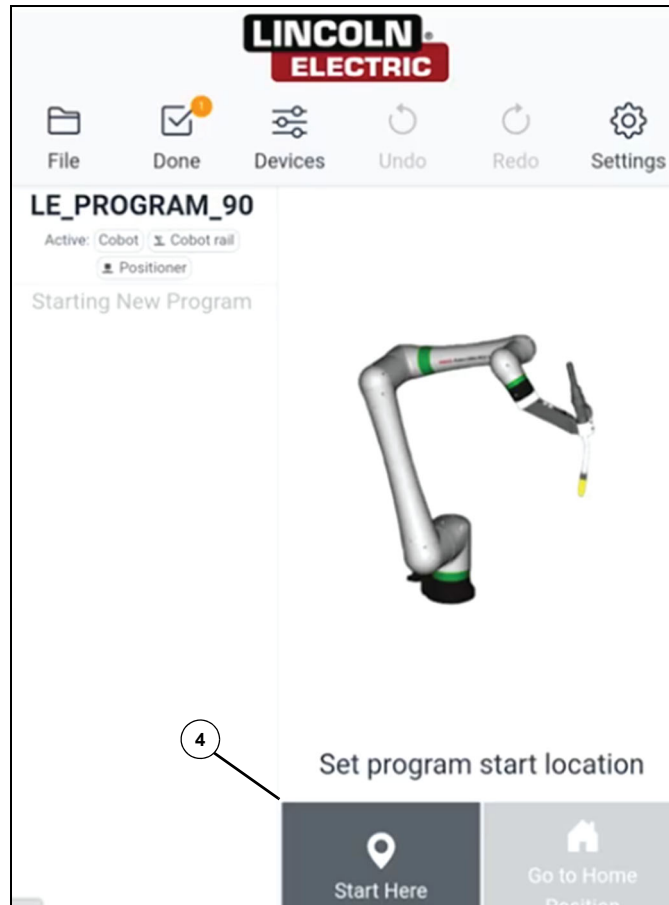

Figure 4-7

4. Press the blue button to unlock the robot. Move the robot by hand to the weld start position and press the green button.
5. To jog the positioner to the next position, move the robot up and out of the way of the part.

6. Select Devices (5) and scroll down to find Positioner. Use the slider (6) to jog the positioner to the next position or select Current position (7) and manually type in the desired location. Move Cobot back into position and press the green button to create a point.

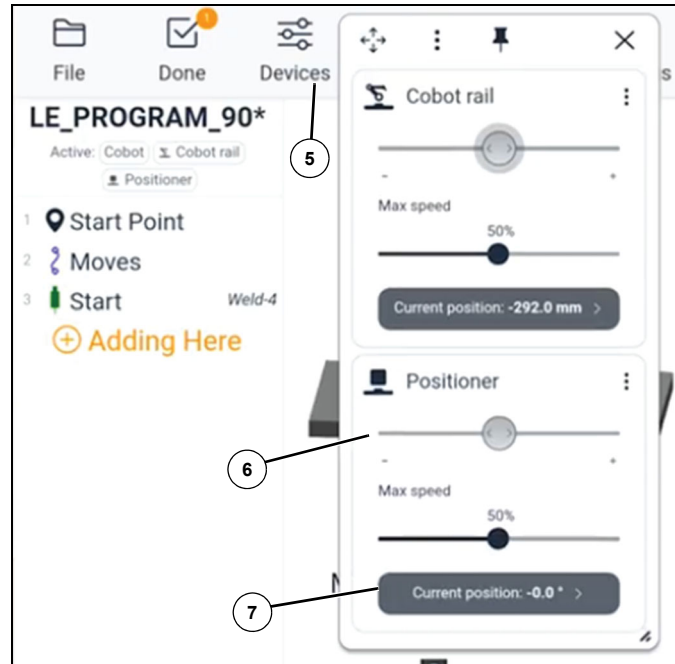

Figure 4-8

Note: For welds going around a rotated part, such as a pipe, ensure that Circular weld points are being taught.

7. Repeat steps 4–6 as many times as needed. When all points are recorded, select Done and run the program.

HOW TO TEACH A PROGRAM WITH A DUAL STATION SETUP

1. Go to the File menu (1) and select New (2).

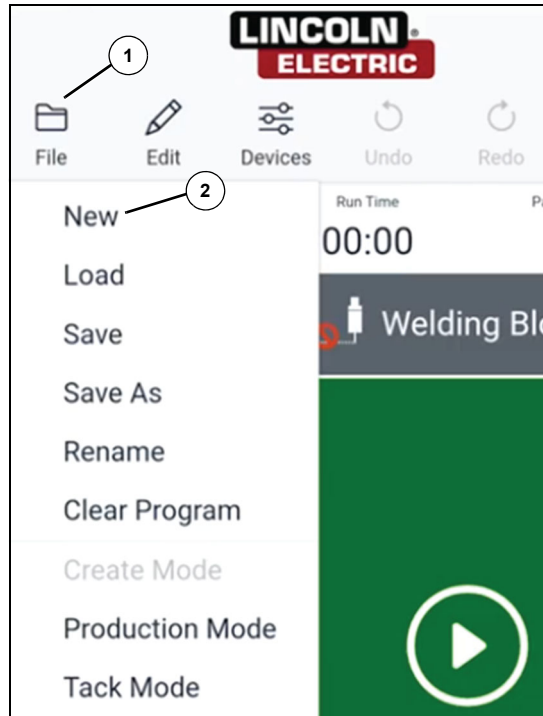

Figure 4-9

2. Ensure that Positioner (3) is checked.

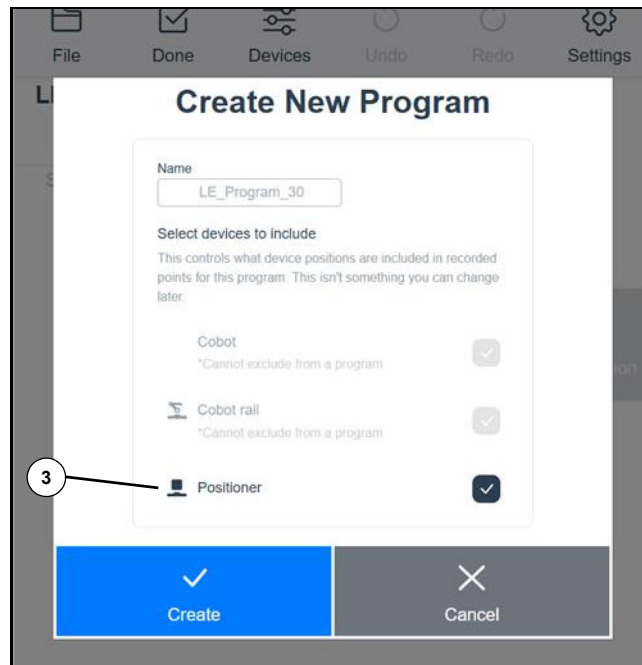

Figure 4-10

3. To start, define to the home position by moving the cobot up and out of the way, free from any parts or obstructions. Select Start Here (4).

Note: Make this position clear of any weld screens set up on the table when moving along the rail to different zones.

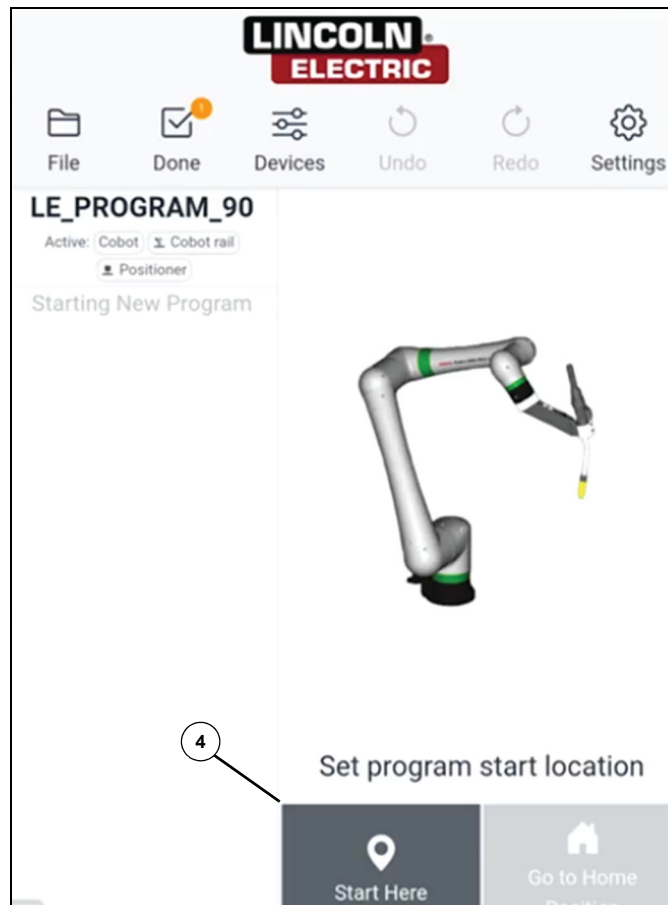

Figure 4-11

4. Move the Cobot along the rail to the desired side of the weld screen.
5. Press the blue button to unlock the robot. Move the robot by hand to the weld start position and press the green button. Continue making all desired weld points.
6. Once all weld points are taught, move the robot up and out of the way of the part, free from any obstructions.

7. Select More Choices (5).

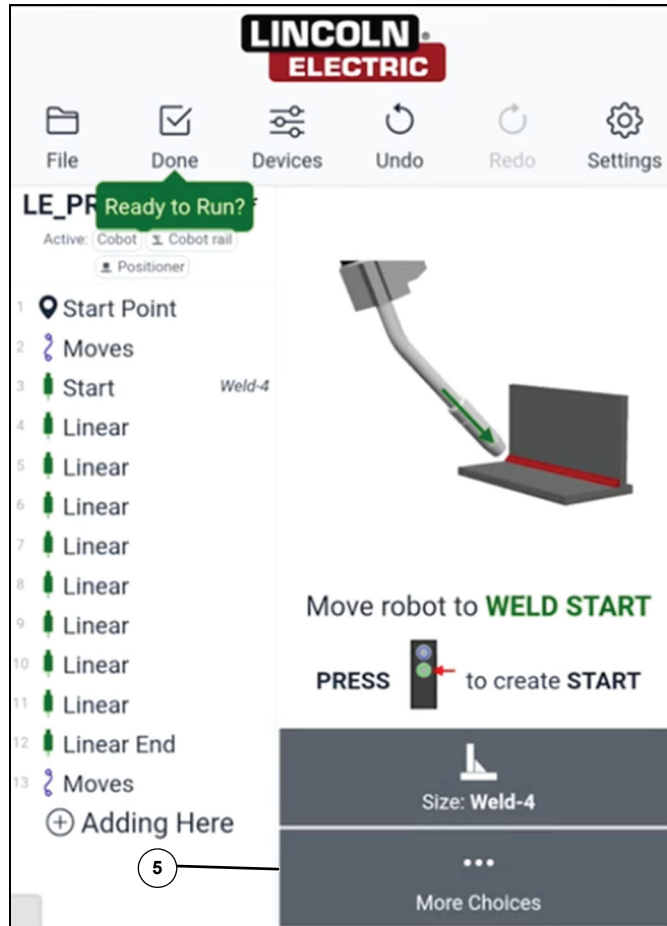

Figure 4-12

8. Select Add Move to Start (6). This is the safe point that was created at the beginning of the program that will clear the weld screen. Select Go to Start Point.

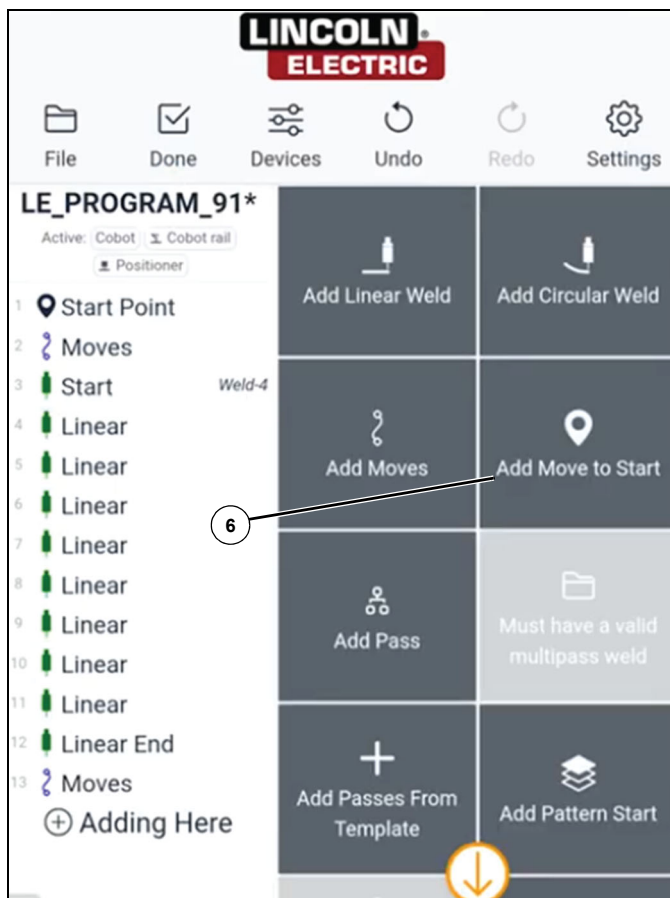

Figure 4-13

9. Move the cobot along the rail. Refer to *How To Teach a Program with a Rail* on page 4-3.

Programming with External Axes

10. Once jogging is complete, close the jog window and select Add Here (7).

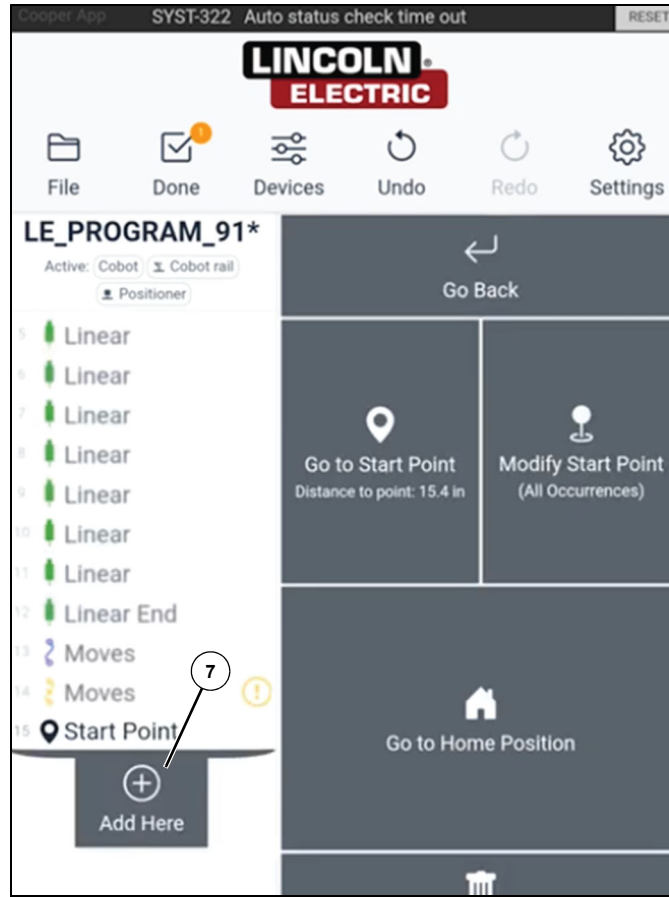

Figure 4-14

11. If using a part with a positioner in the second zone, select Add Circular Weld (8). For more information on how to teach a program with a positioner, Refer to *How to Teach a Program with Positioner on page 4-5*. Otherwise, repeat steps 4–8. When complete, go into More Choices and add another start point so that there is enough clearance for the weld screen.

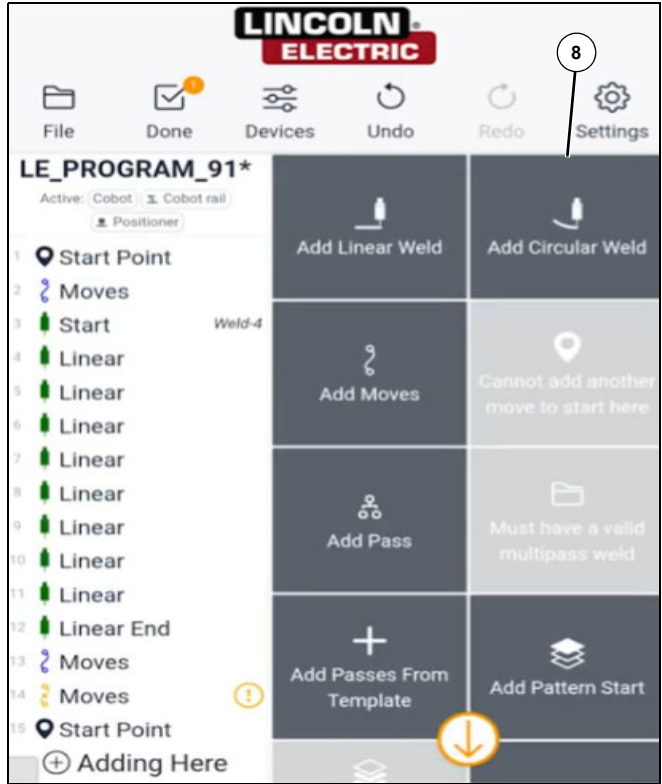

Figure 4-15

12. Select Done. Now the operator will be able to run the program.

Section 5**COBOT TORCH MAINTENANCE****HOW TO TEACH TOOL CENTER POINT (TCP)**

1. Go into the Settings menu and select Setup a TCP.

Note: Following this procedure, all program positions will be affected.

Note: Do not change the stick out length. Do not feed or retract wire while performing this procedure.

Note: The operator will need a pointed object positioned on the tabletop to perform this procedure.

2. Select Start (1) and follow the on-screen steps to Record TCP First Point (2), TCP Second Point (3), TCP Third Point (4), and TCP Fourth Point (5).

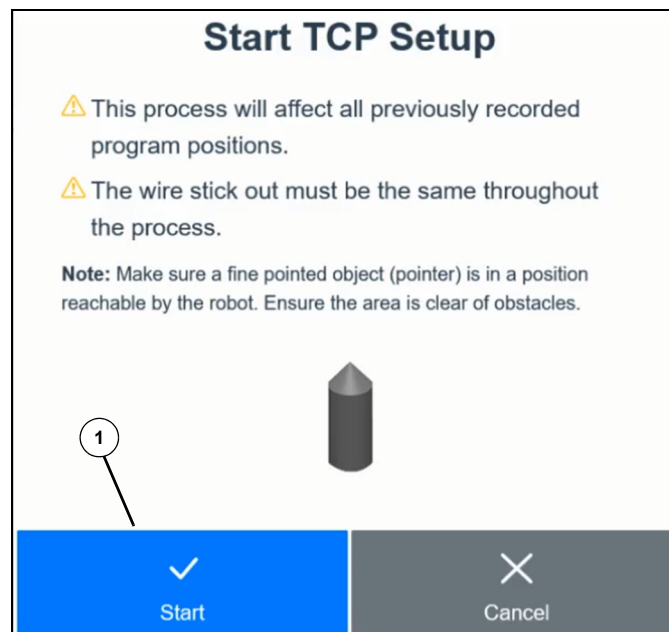

Figure 5-1

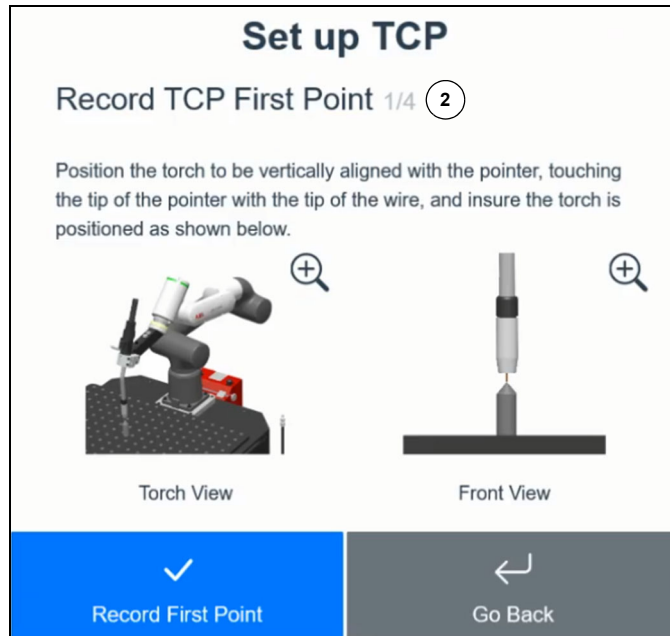

Figure 5-2

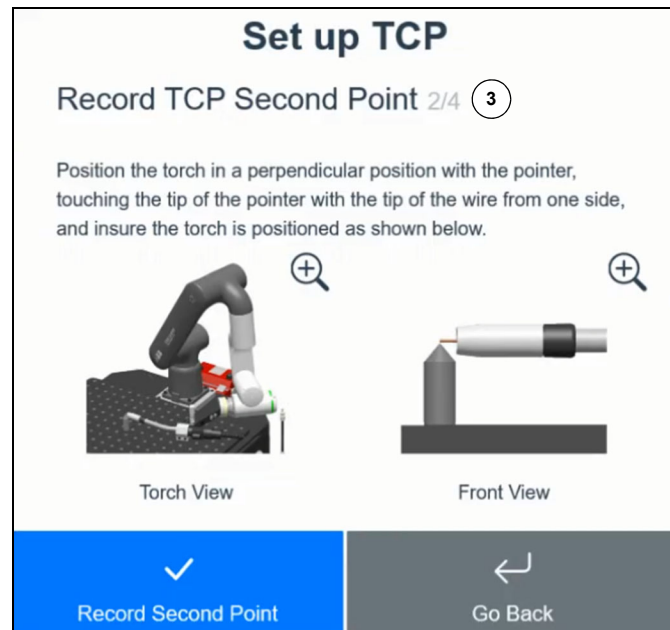

Figure 5-3

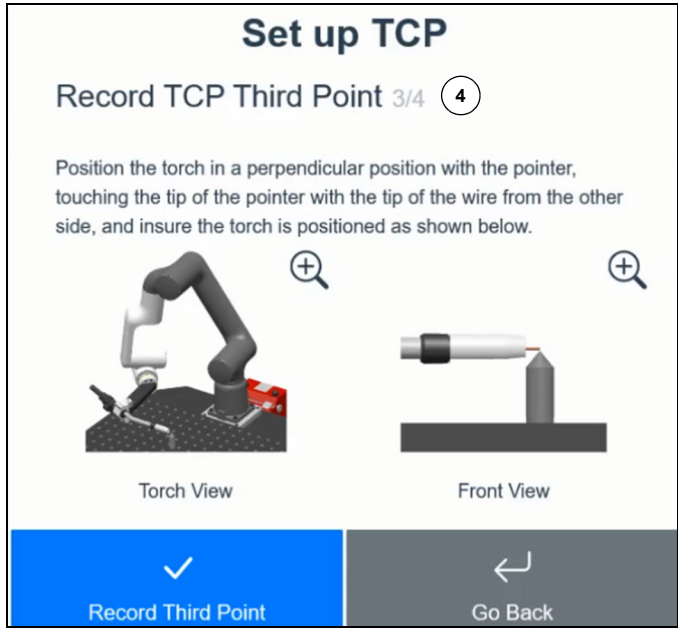

Figure 5-4

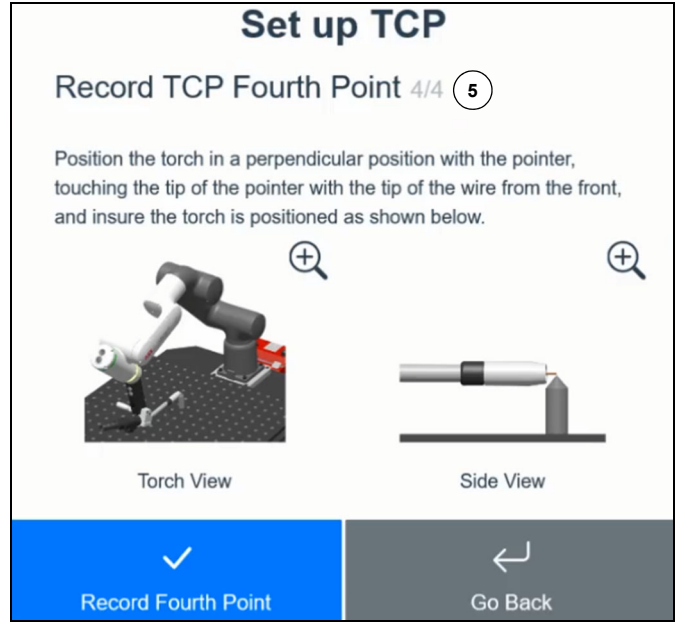

Figure 5-5

3. After all four points are recorded, the Cooper App will ask the operator if all points are correct. If confirmed, the new TCP configuration will overwrite the old configurations.

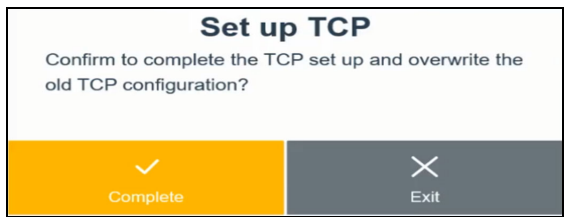

Figure 5-6

HOW TO SET UP POWER REAM PLUS (CRX ONLY)

Note: This feature is only available for systems that have a Power Ream Plus.

1. Go into the Settings (1) menu and select Set up Torch Cleaner (2).

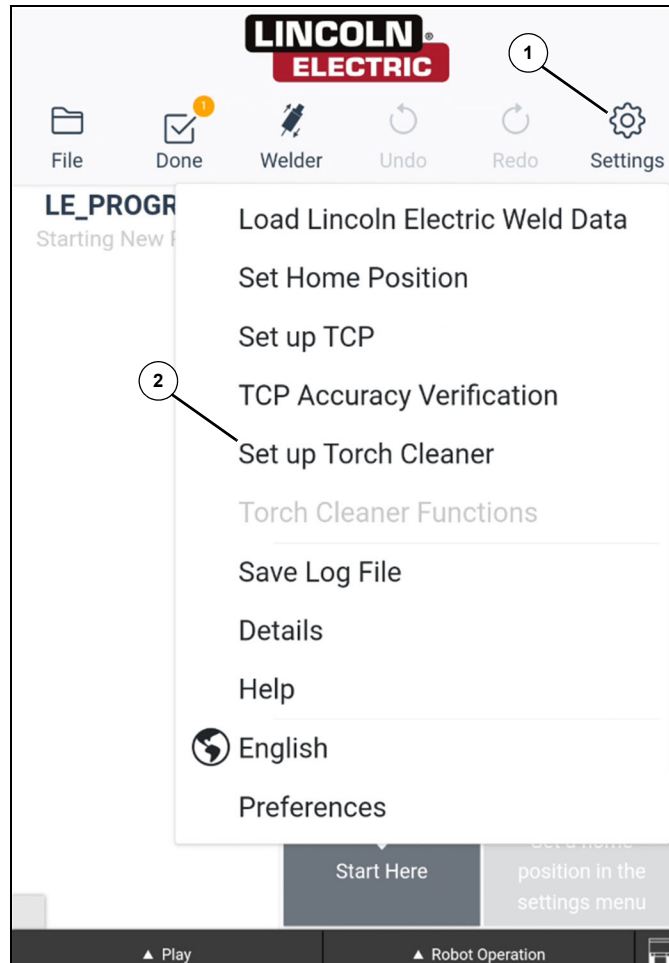

Figure 5-7

Note: For all points recorded in setting up the Power Ream Plus, the torch must be in a vertical position.

2. Teach the approach position. This position is up and out of the way of any obstacles and reamer. Unlock and move the torch close to where the reamer is located. Select Record Approach Position (3).

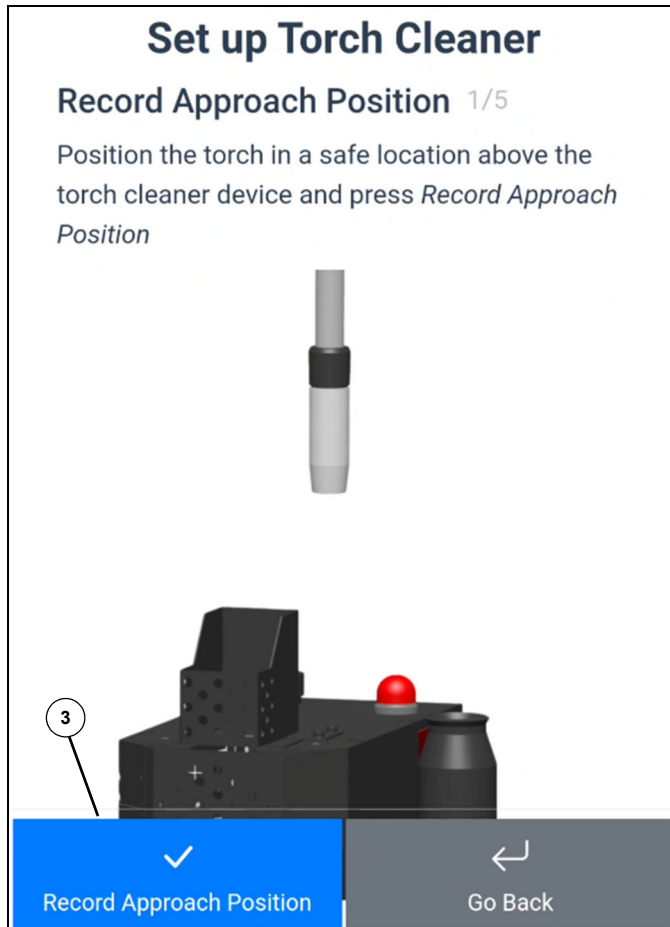

Figure 5-8

3. Teach the wire cut. Once the torch is positioned in the wire cut position, move the nozzle to the desired height above the wire cutter to set the stick out length. If the nozzle is flush with the wire cutter, it will give you a stick out of 10 mm. Select Record Wire Cut Position (4).

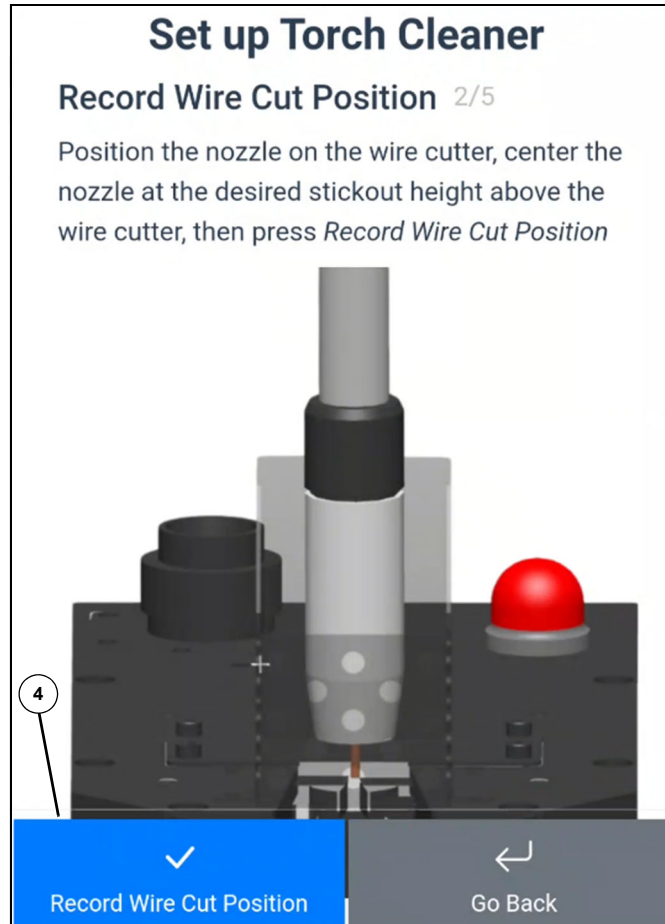

Figure 5-9

4. Teach approach for the reamer bit. Move the torch so that it is centered in the gap above the reamer bed. Select Record Clamp Approach Position (5).

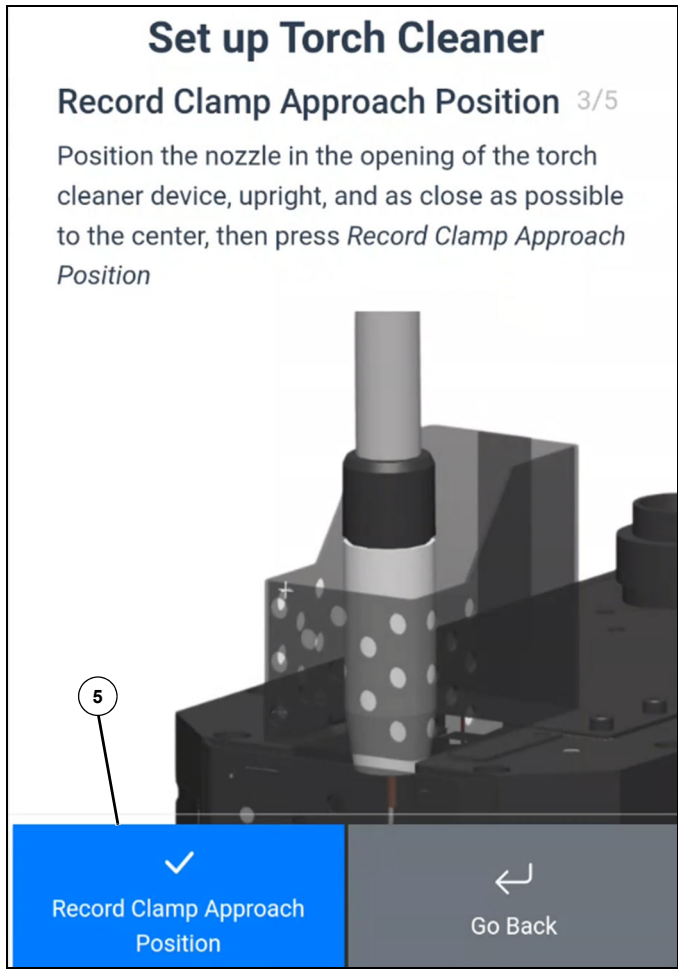

Figure 5-10

5. Teach the clamp position. Move the torch as close to the reaming bit as possible while keeping the torch centered. Select Record Clamp Position (6).

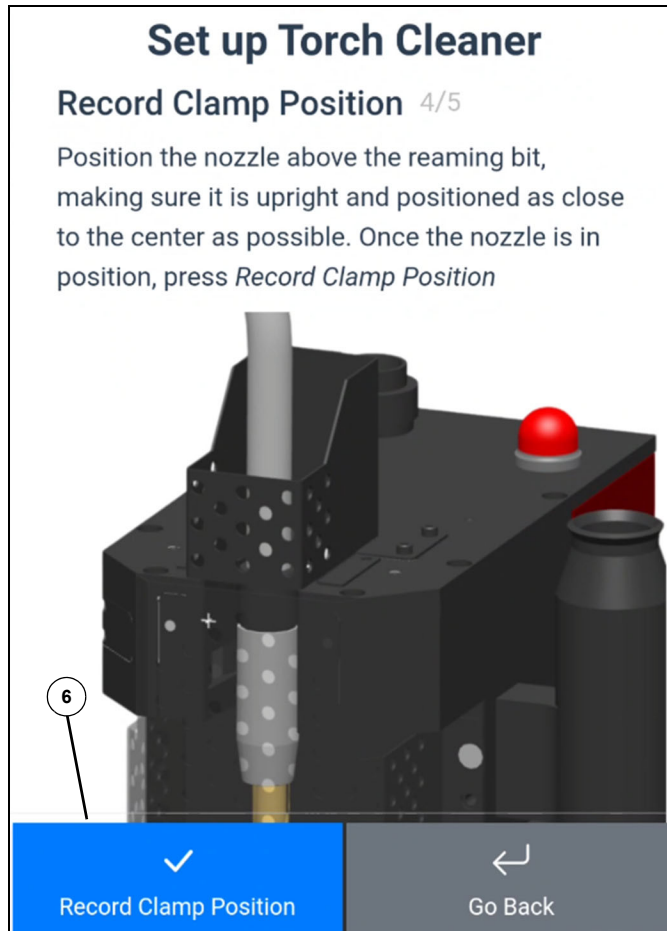

Figure 5-11

6. Teach the spray position. Move the torch up and out of the way of the reamer and over to the spray. Select Record Spray Position (7).

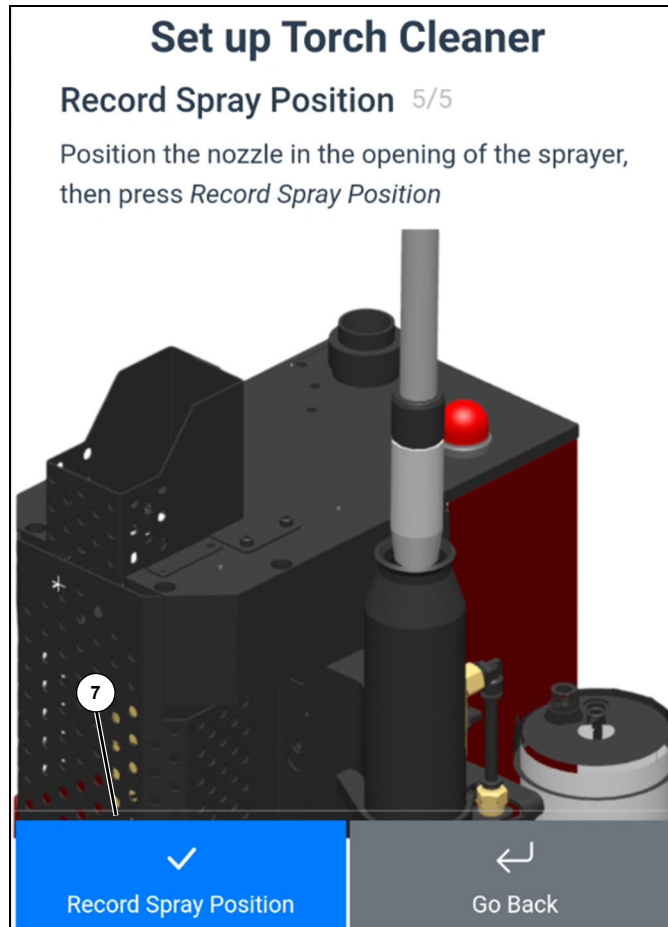

Figure 5-12

SERVICE ROUTINES SCHEDULER

1. The operator can add a service routine into an existing program by selecting the location in the program where the service routine will be placed. Then select the Add Here icon (1).

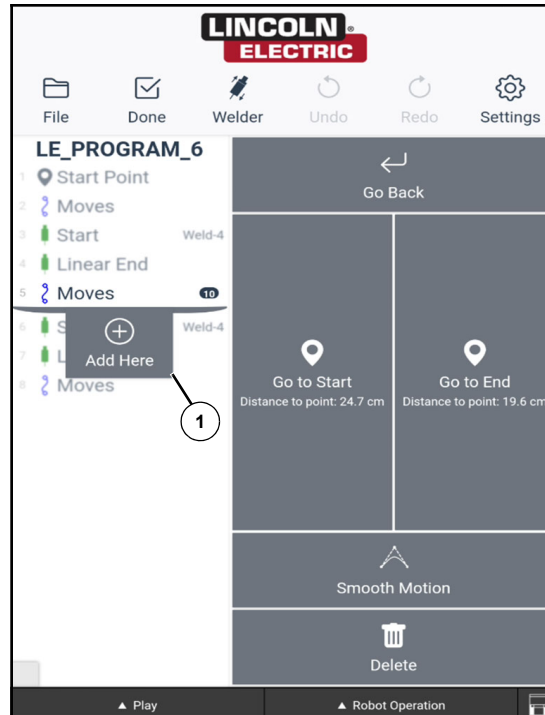

Figure 5-13

2. Scroll down on the right side icons and select Add Service Routine icon (2).

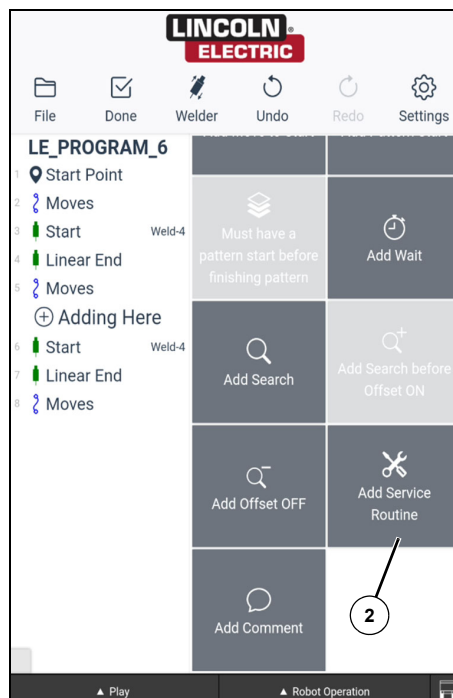

Figure 5-14

- The operator will be presented with four service routine options: Manual Wire Cut (3), Manual Torch Clean (4), Wire Cut (5), and Torch Clean (6). To add in a manual service routine, select the desired operation.

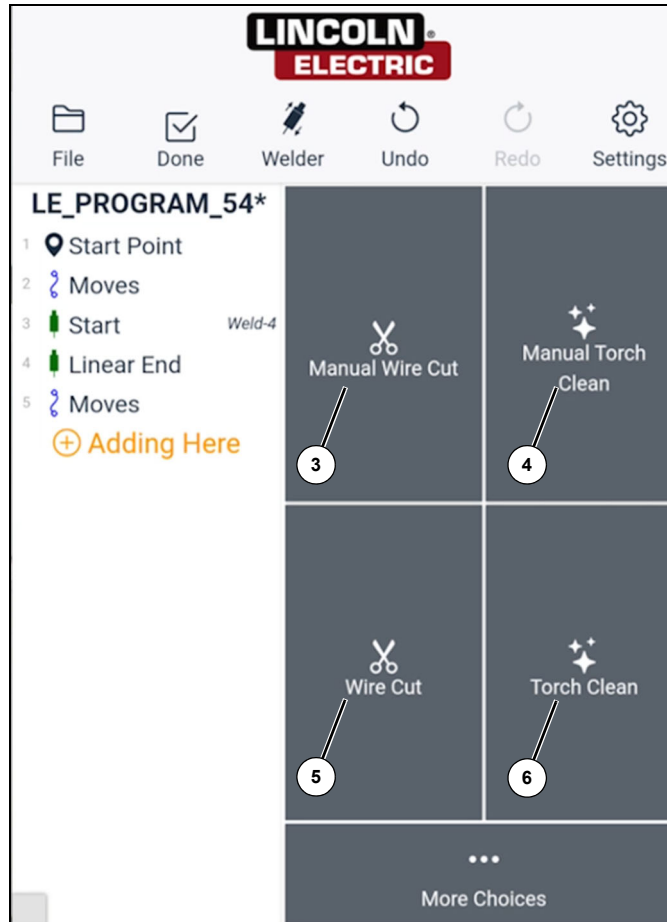

Figure 5-15

- Select the Done icon to write the service routine into the program.
- Run the program.

- When the program reaches the service routine step, complete the service routine that was selected in step 3 and select RESET (6).

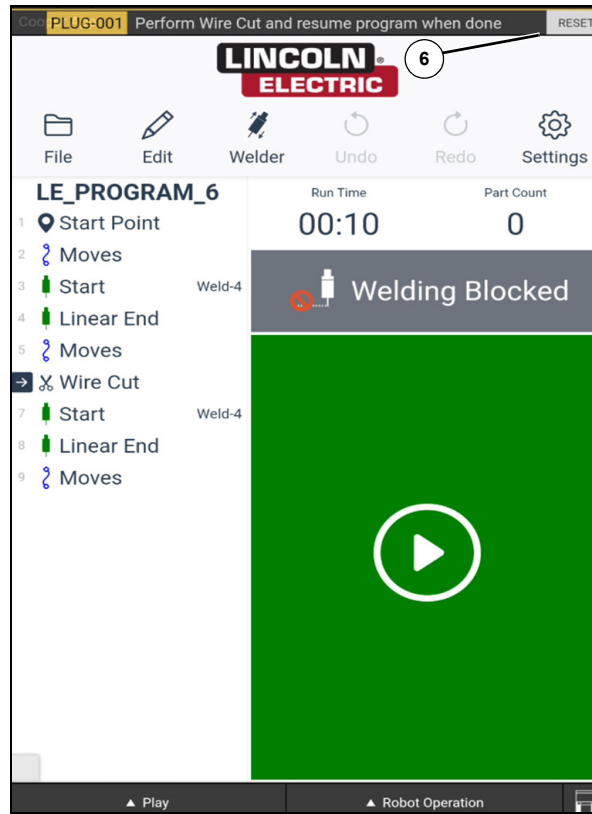

Figure 5-16

- Press the Play button to resume and complete the program.

HOW TO USE POWER REAM PLUS

Before using Power Ream Plus, see *How To Set Up Power Ream Plus (CRX only) on page 5-4.*

1. Using an existing program, select the More Choices menu and select Add Service Routine (1).

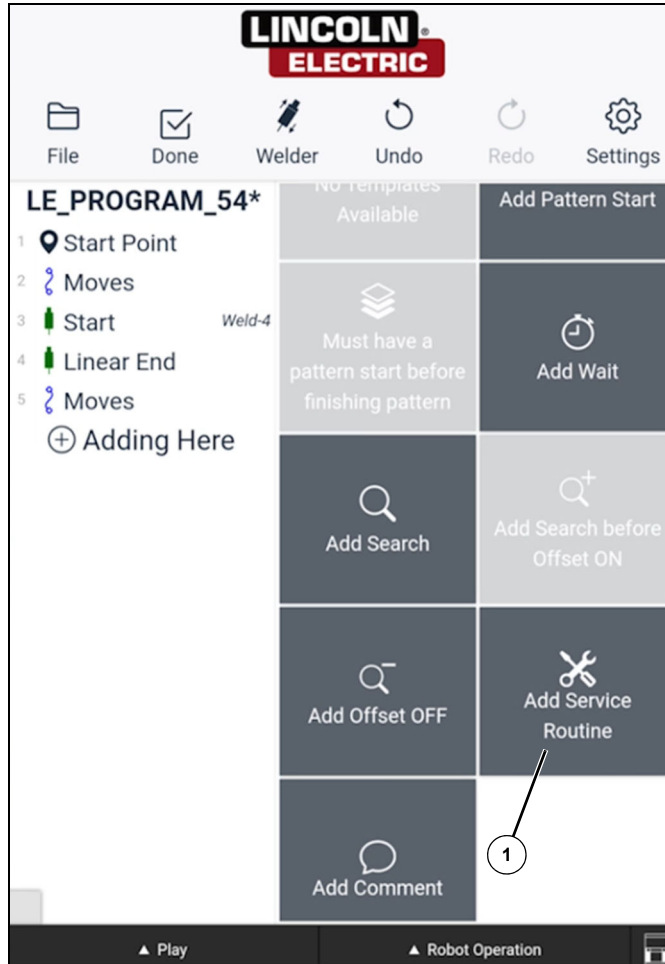

Figure 5-17

- Next, the operator will be given two options: Wire Cut (2) or Torch Clean (3) (both are available in manual or automatic). Torch Clean will include wire cut, torch clean, and spray.

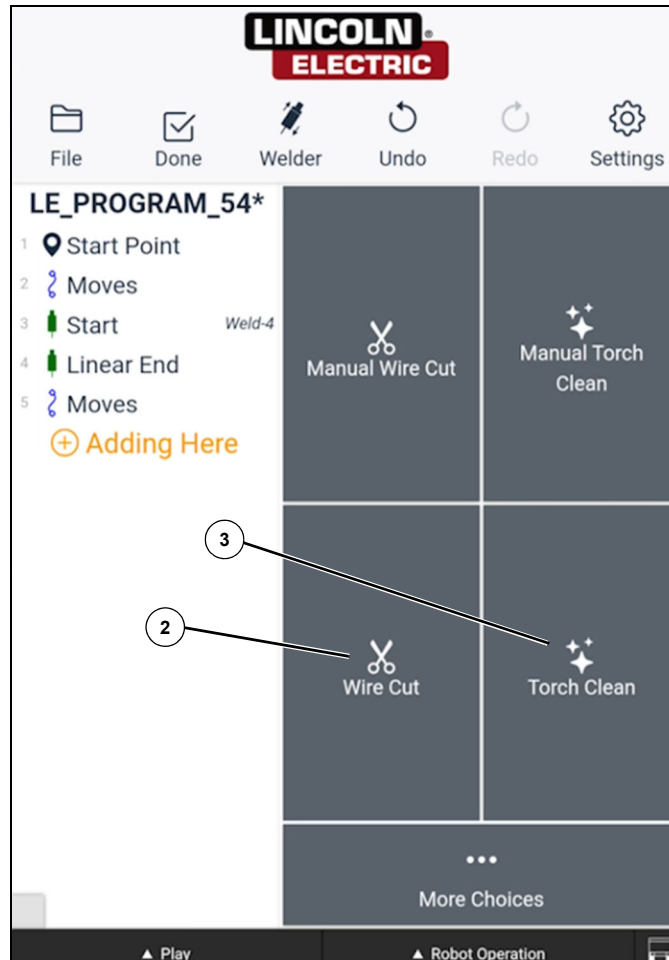

Figure 5-18

- Once added to the program, the Cooper App will now prompt the operator to solve an unverified move by automatically fixing the error or fixing the error manually, see *How To Resolve Unverified Moves on page 2-11* for more information. This move will teach the cobot how to get from the current position to the reamer Approach position.
- Select Done. Now the operator will be able to run the program.

GLOSSARY

Cooper App

A Lincoln Electric Company proprietary software interface, designed to deliver a simplified user experience when programming weld sequences on a collaborative robot.

Consumables

During the welding process there are materials like welding gas and welding wire that is consumed. Defining the correct consumables used during set-up is critical to the delivery of a consistent quality weld.

Linear Weld

A weld that is arranged in or extending along a straight or nearly straight line.

Circular Weld

Any weld path that isn't a linear path including Circles, Arcs and Bends etc.

Weld by Numbers

A Lincoln Electric Company proprietary software feature that simplifies the welding process by predefining a multitude of weld parameters needed to produce a quality weld and allowing the user to easily select the number that best represents the intended weld.

Custom Weld

In the off case where the "Weld by Number" settings do not deliver an optimum weld users can modify the predefined weld settings to deliver the best possible weld for the materials used.

Air Moves

The motion of a robot arm during a weld program where arc welding is not being conducted. This can consist of motion between a home position to the first weld or from the last weld in a program. Movements between welds can also consist of 'air moves'.

Weld Points

Every robotic weld program has a series of points or targets that define the tool path trajectory in which the robot arm will follow. This can include Weld Start Point, Weld End Point and Via Points.

Angle Tuner

When performing a weld the angle in which you teach your robot to perform has a significant impact on the quality of the weld that is produced. The Angle Tuner provides users with a tool to simplify the adjustment of the Work Angel, Travel Angle and Torch Spin.

Weld Pattern

In situations when multiples of the same part can be positioned within a fixture providing equal spacing between parts or when a single part has a repetitive design with equal spacing between weldments the Weld Pattern feature can be utilized to easily duplicate a single taught weld path over the subsequent weldments.

Glossary

Batcher / Scheduler

When multiple weld programs are present for either a single part or multiple parts the batcher feature found within production mode can be used to select and group all relevant programs required to complete the entire job. Programs can also be easily scheduled to be performed at different intervals within the overall job.

Service Routines

When conducting continuous welding operations within a robotic welding environment it is often necessary to perform regular preventative maintenance services like, cleaning torch gas cup or cutting weld wire. The Service Routine feature allows you to easily schedule a service routine within a program. When the service routine is reached the program will pause and the user prompted to perform the service and then allowed to resume the program.

Stitch Weld

An intermittent weld where a weld is applied to a defined portion of the joint followed by a defined space which is then followed by a defined portion of joint. This is repeated along the duration of the programmed weld. Stitch welds are used to limit the amount of heat transferred to the part to prevent or reduce part distortion. Stitch welds can also reduce the cost by reducing the amount of consumables used.

Search

Imperfect tooling and part inconsistencies can cause weld joints to deviate greatly from the programmed weld path. Touch Sensing works by using the welding electrode to make electrical contact with the part and identify its location. The robot stores the position data and then makes offset adjustments automatically to the entire weld path to accommodate for inconsistencies in the seam location between alike parts.

Thru-Arc™ Tracking

Thru-Arc™ Tracking, also known as Seam or Joint Tracking, involves real-time tracking just ahead of where the weld path has been programmed. This tracking information is used to automatically adapt the trajectory of the robot arm during the welding operation, ensuring that the weld path correctly follows any deviations within the seam of the part.

Multipass Welding

Multipass welding is a process in which more than one pass of the weld is made on a joint. A pass is a single bead of weld metal that runs along the length of the joint. Multipass welding allows you to fill a large gap or groove with multiple layers of weld metal, each one covering the previous one. Multi-pass welds are often found in industries such as structural fabrication, pipeline and shipbuilding.

CUSTOMER ASSISTANCE POLICY

The business of Lincoln Electric is manufacturing and selling high quality welding equipment, automated welding systems, consumables, and cutting equipment. Our challenge is to meet the needs of our customers, who are experts in their fields, and to exceed their expectations. On occasion, purchasers may ask Lincoln Electric for information or technical information about their use of our products. Our employees respond to inquiries to the best of their ability based on information and specifications provided to them by the customers and the knowledge they may have concerning the application. Our employees, however, are not in a position to verify the information provided or to evaluate the engineering requirements for the particular weldment, or to provide engineering advice in relation to a specific situation or application. Accordingly, Lincoln Electric does not warrant or guarantee or assume any liability with respect to such information or communications. Moreover, the provision of such information or technical information does not create, expand, or alter any warranty on our products. Any express or implied warranty that might arise from the information or technical information, including any implied warranty of merchantability or any warranty of fitness for any customers' particular purpose or any other equivalent or similar warranty is specifically disclaimed.

Lincoln Electric is a responsive manufacturer, but the definition of specifications, and the selection and use of specific products sold by Lincoln Electric is solely within the control of, and remains the sole responsibility of the customer. Many variables beyond the control of Lincoln Electric affect the results obtained in applying these types of fabrication methods and service requirements.

WELD FUME CONTROL EQUIPMENT

The operation of welding fume control equipment is affected by various factors including proper use and positioning of the equipment, maintenance of the equipment and the specific welding procedure and application involved. Worker exposure level should be checked upon installation and periodically thereafter to be certain it is within applicable OSHA PEL and ACGIH TLV limits.



THE LINCOLN ELECTRIC COMPANY

22801 St. Clair Avenue • Cleveland, OH • 44117-1199 • U.S.A.
Phone: +1.216.481.8100 • www.lincolnelectric.com