

POWER WAVE® i400

For use with machines having Code Numbers: 11536, 11536R, 11775

Safety Depends on You

Lincoln arc welding and cutting equipment is designed and built with safety in mind. However, your overall safety can be increased by proper installation ... and thoughtful operation on your part. **DO NOT INSTALL, OPERATE OR REPAIR THIS EQUIPMENT WITHOUT READING THIS MANUAL AND THE SAFETY PRECAUTIONS CONTAINED THROUGHOUT.** And, most importantly, think before you act and be careful.

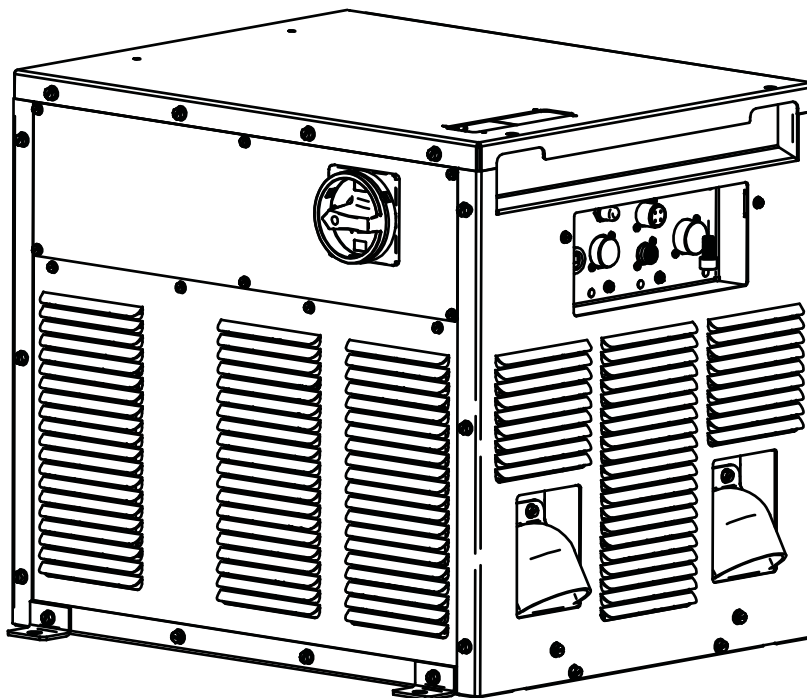

OPERATOR'S MANUAL



LINCOLN[®]
ELECTRIC

Copyright © Lincoln Global Inc.

- World's Leader in Welding and Cutting Products •
- Sales and Service through Subsidiaries and Distributors Worldwide •

Cleveland, Ohio 44117-1199 U.S.A. TEL: 216.481.8100 FAX: 216.486.1751 WEB SITE: www.lincolnelectric.com

THANK YOU FOR SELECTING A QUALITY PRODUCT BY LINCOLN ELECTRIC.

PLEASE EXAMINE CARTON AND EQUIPMENT FOR DAMAGE IMMEDIATELY

When this equipment is shipped, title passes to the purchaser upon receipt by the carrier. Consequently, claims for material damaged in shipment must be made by the purchaser against the transportation company at the time the shipment is received.

SAFETY DEPENDS ON YOU

Lincoln arc welding and cutting equipment is designed and built with safety in mind. However, your overall safety can be increased by proper installation ... and thoughtful operation on your part. **DO NOT INSTALL, OPERATE OR REPAIR THIS EQUIPMENT WITHOUT READING THIS MANUAL AND THE SAFETY PRECAUTIONS CONTAINED THROUGHOUT.** And, most importantly, think before you act and be careful.

WARNING

This statement appears where the information must be followed exactly to avoid serious personal injury or loss of life.

CAUTION

This statement appears where the information must be followed to avoid minor personal injury or damage to this equipment.



KEEP YOUR HEAD OUT OF THE FUMES.

DON'T get too close to the arc. Use corrective lenses if necessary to stay a reasonable distance away from the arc.

READ and obey the Safety Data Sheet (SDS) and the warning label that appears on all containers of welding materials.

USE ENOUGH VENTILATION or exhaust at the arc, or both, to keep the fumes and gases from your breathing zone and the general area.

IN A LARGE ROOM OR OUTDOORS, natural ventilation may be adequate if you keep your head out of the fumes (See below).

USE NATURAL DRAFTS or fans to keep the fumes away from your face.

If you develop unusual symptoms, see your supervisor. Perhaps the welding atmosphere and ventilation system should be checked.



WEAR CORRECT EYE, EAR & BODY PROTECTION

PROTECT your eyes and face with welding helmet properly fitted and with proper grade of filter plate (See ANSI Z49.1).

PROTECT your body from welding spatter and arc flash with protective clothing including woolen clothing, flame-proof apron and gloves, leather leggings, and high boots.

PROTECT others from splatter, flash, and glare with protective screens or barriers.

IN SOME AREAS, protection from noise may be appropriate.

BE SURE protective equipment is in good condition.

Also, wear safety glasses in work area **AT ALL TIMES.**



SPECIAL SITUATIONS

DO NOT WELD OR CUT containers or materials which previously had been in contact with hazardous substances unless they are properly cleaned. This is extremely dangerous.

DO NOT WELD OR CUT painted or plated parts unless special precautions with ventilation have been taken. They can release highly toxic fumes or gases.

Additional precautionary measures

PROTECT compressed gas cylinders from excessive heat, mechanical shocks, and arcs; fasten cylinders so they cannot fall.

BE SURE cylinders are never grounded or part of an electrical circuit.

REMOVE all potential fire hazards from welding area.

ALWAYS HAVE FIRE FIGHTING EQUIPMENT READY FOR IMMEDIATE USE AND KNOW HOW TO USE IT.



SECTION A: WARNINGS



CALIFORNIA PROPOSITION 65 WARNINGS



WARNING: Breathing diesel engine exhaust exposes you to chemicals known to the State of California to cause cancer and birth defects, or other reproductive harm.

- Always start and operate the engine in a well-ventilated area.
- If in an exposed area, vent the exhaust to the outside.
- Do not modify or tamper with the exhaust system.
- Do not idle the engine except as necessary.

For more information go to www.P65warnings.ca.gov/diesel

WARNING: This product, when used for welding or cutting, produces fumes or gases which contain chemicals known to the State of California to cause birth defects and, in some cases, cancer. (California Health & Safety Code § 25249.5 *et seq.*)



WARNING: Cancer and Reproductive Harm
www.P65warnings.ca.gov

ARC WELDING CAN BE HAZARDOUS. PROTECT YOURSELF AND OTHERS FROM POSSIBLE SERIOUS INJURY OR DEATH. KEEP CHILDREN AWAY. PACEMAKER WEARERS SHOULD CONSULT WITH THEIR DOCTOR BEFORE OPERATING.

Read and understand the following safety highlights. For additional safety information, it is strongly recommended that you purchase a copy of "Safety in Welding & Cutting - ANSI Standard Z49.1" from the American Welding Society, P.O. Box 351040, Miami, Florida 33135 or CSA Standard W117.2-1974. A Free copy of "Arc Welding Safety" booklet E205 is available from the Lincoln Electric Company, 22801 St. Clair Avenue, Cleveland, Ohio 44117-1199.

BE SURE THAT ALL INSTALLATION, OPERATION, MAINTENANCE AND REPAIR PROCEDURES ARE PERFORMED ONLY BY QUALIFIED INDIVIDUALS.



FOR ENGINE POWERED EQUIPMENT.

- 1.a. Turn the engine off before troubleshooting and maintenance work unless the maintenance work requires it to be running.
- 1.b. Operate engines in open, well-ventilated areas or vent the engine exhaust fumes outdoors.
- 1.c. Do not add the fuel near an open flame welding arc or when the engine is running. Stop the engine and allow it to cool before refueling to prevent spilled fuel from vaporizing on contact



with hot engine parts and igniting. Do not spill fuel when filling tank. If fuel is spilled, wipe it up and do not start engine until fumes have been eliminated.

- 1.d. Keep all equipment safety guards, covers and devices in position and in good repair. Keep hands, hair, clothing and tools away from V-belts, gears, fans and all other moving parts when starting, operating or repairing equipment.
- 1.e. In some cases it may be necessary to remove safety guards to perform required maintenance. Remove guards only when necessary and replace them when the maintenance requiring their removal is complete. Always use the greatest care when working near moving parts.
- 1.f. Do not put your hands near the engine fan. Do not attempt to override the governor or idler by pushing on the throttle control rods while the engine is running.
- 1.g. To prevent accidentally starting gasoline engines while turning the engine or welding generator during maintenance work, disconnect the spark plug wires, distributor cap or magneto wire as appropriate.
- 1.h. To avoid scalding, do not remove the radiator pressure cap when the engine is hot.



ELECTRIC AND MAGNETIC FIELDS MAY BE DANGEROUS



- 2.a. Electric current flowing through any conductor causes localized Electric and Magnetic Fields (EMF). Welding current creates EMF fields around welding cables and welding machines
- 2.b. EMF fields may interfere with some pacemakers, and welders having a pacemaker should consult their physician before welding.
- 2.c. Exposure to EMF fields in welding may have other health effects which are now not known.
- 2.d. All welders should use the following procedures in order to minimize exposure to EMF fields from the welding circuit:
 - 2.d.1. Route the electrode and work cables together - Secure them with tape when possible.
 - 2.d.2. Never coil the electrode lead around your body.
 - 2.d.3. Do not place your body between the electrode and work cables. If the electrode cable is on your right side, the work cable should also be on your right side.
 - 2.d.4. Connect the work cable to the workpiece as close as possible to the area being welded.
 - 2.d.5. Do not work next to welding power source.



ELECTRIC SHOCK CAN KILL.



- 3.a. The electrode and work (or ground) circuits are electrically “hot” when the welder is on. Do not touch these “hot” parts with your bare skin or wet clothing. Wear dry, hole-free gloves to insulate hands.
- 3.b. Insulate yourself from work and ground using dry insulation. Make certain the insulation is large enough to cover your full area of physical contact with work and ground.

In addition to the normal safety precautions, if welding must be performed under electrically hazardous conditions (in damp locations or while wearing wet clothing; on metal structures such as floors, gratings or scaffolds; when in cramped positions such as sitting, kneeling or lying, if there is a high risk of unavoidable or accidental contact with the workpiece or ground) use the following equipment:

- Semiautomatic DC Constant Voltage (Wire) Welder.
 - DC Manual (Stick) Welder.
 - AC Welder with Reduced Voltage Control.
- 3.c. In semiautomatic or automatic wire welding, the electrode, electrode reel, welding head, nozzle or semiautomatic welding gun are also electrically “hot”.
 - 3.d. Always be sure the work cable makes a good electrical connection with the metal being welded. The connection should be as close as possible to the area being welded.
 - 3.e. Ground the work or metal to be welded to a good electrical (earth) ground.
 - 3.f. Maintain the electrode holder, work clamp, welding cable and welding machine in good, safe operating condition. Replace damaged insulation.
 - 3.g. Never dip the electrode in water for cooling.
 - 3.h. Never simultaneously touch electrically “hot” parts of electrode holders connected to two welders because voltage between the two can be the total of the open circuit voltage of both welders.
 - 3.i. When working above floor level, use a safety belt to protect yourself from a fall should you get a shock.
 - 3.j. Also see Items 6.c. and 8.



ARC RAYS CAN BURN.



- 4.a. Use a shield with the proper filter and cover plates to protect your eyes from sparks and the rays of the arc when welding or observing open arc welding. Headshield and filter lens should conform to ANSI Z87.1 standards.
- 4.b. Use suitable clothing made from durable flame-resistant material to protect your skin and that of your helpers from the arc rays.
- 4.c. Protect other nearby personnel with suitable, non-flammable screening and/or warn them not to watch the arc nor expose themselves to the arc rays or to hot spatter or metal.



FUMES AND GASES CAN BE DANGEROUS.



- 5.a. Welding may produce fumes and gases hazardous to health. Avoid breathing these fumes and gases. When welding, keep your head out of the fume. Use enough ventilation and/or exhaust at the arc to keep fumes and gases away from the breathing zone. **When welding hardfacing (see instructions on container or SDS) or on lead or cadmium plated steel and other metals or coatings which produce highly toxic fumes, keep exposure as low as possible and within applicable OSHA PEL and ACGIH TLV limits using local exhaust or mechanical ventilation unless exposure assessments indicate otherwise. In confined spaces or in some circumstances, outdoors, a respirator may also be required. Additional precautions are also required when welding on galvanized steel.**
- 5.b. The operation of welding fume control equipment is affected by various factors including proper use and positioning of the equipment, maintenance of the equipment and the specific welding procedure and application involved. Worker exposure level should be checked upon installation and periodically thereafter to be certain it is within applicable OSHA PEL and ACGIH TLV limits.
- 5.c. Do not weld in locations near chlorinated hydrocarbon vapors coming from degreasing, cleaning or spraying operations. The heat and rays of the arc can react with solvent vapors to form phosgene, a highly toxic gas, and other irritating products.
- 5.d. Shielding gases used for arc welding can displace air and cause injury or death. Always use enough ventilation, especially in confined areas, to insure breathing air is safe.
- 5.e. Read and understand the manufacturer’s instructions for this equipment and the consumables to be used, including the Safety Data Sheet (SDS) and follow your employer’s safety practices. SDS forms are available from your welding distributor or from the manufacturer.
- 5.f. Also see item 1.b.



WELDING AND CUTTING SPARKS CAN CAUSE FIRE OR EXPLOSION.



- 6.a. Remove fire hazards from the welding area. If this is not possible, cover them to prevent the welding sparks from starting a fire. Remember that welding sparks and hot materials from welding can easily go through small cracks and openings to adjacent areas. Avoid welding near hydraulic lines. Have a fire extinguisher readily available.
- 6.b. Where compressed gases are to be used at the job site, special precautions should be used to prevent hazardous situations. Refer to "Safety in Welding and Cutting" (ANSI Standard Z49.1) and the operating information for the equipment being used.
- 6.c. When not welding, make certain no part of the electrode circuit is touching the work or ground. Accidental contact can cause overheating and create a fire hazard.
- 6.d. Do not heat, cut or weld tanks, drums or containers until the proper steps have been taken to insure that such procedures will not cause flammable or toxic vapors from substances inside. They can cause an explosion even though they have been "cleaned". For information, purchase "Recommended Safe Practices for the Preparation for Welding and Cutting of Containers and Piping That Have Held Hazardous Substances", AWS F4.1 from the American Welding Society (see address above).
- 6.e. Vent hollow castings or containers before heating, cutting or welding. They may explode.
- 6.f. Sparks and spatter are thrown from the welding arc. Wear oil free protective garments such as leather gloves, heavy shirt, cuffless trousers, high shoes and a cap over your hair. Wear ear plugs when welding out of position or in confined places. Always wear safety glasses with side shields when in a welding area.
- 6.g. Connect the work cable to the work as close to the welding area as practical. Work cables connected to the building framework or other locations away from the welding area increase the possibility of the welding current passing through lifting chains, crane cables or other alternate circuits. This can create fire hazards or overheat lifting chains or cables until they fail.
- 6.h. Also see item 1.c.
- 6.i. Read and follow NFPA 51B "Standard for Fire Prevention During Welding, Cutting and Other Hot Work", available from NFPA, 1 Batterymarch Park, PO box 9101, Quincy, MA 022690-9101.
- 6.j. Do not use a welding power source for pipe thawing.



CYLINDER MAY EXPLODE IF DAMAGED.



- 7.a. Use only compressed gas cylinders containing the correct shielding gas for the process used and properly operating regulators designed for the gas and pressure used. All hoses, fittings, etc. should be suitable for the application and maintained in good condition.
- 7.b. Always keep cylinders in an upright position securely chained to an undercarriage or fixed support.
- 7.c. Cylinders should be located:
 - Away from areas where they may be struck or subjected to physical damage.
 - A safe distance from arc welding or cutting operations and any other source of heat, sparks, or flame.
- 7.d. Never allow the electrode, electrode holder or any other electrically "hot" parts to touch a cylinder.
- 7.e. Keep your head and face away from the cylinder valve outlet when opening the cylinder valve.
- 7.f. Valve protection caps should always be in place and hand tight except when the cylinder is in use or connected for use.
- 7.g. Read and follow the instructions on compressed gas cylinders, associated equipment, and CGA publication P-1, "Precautions for Safe Handling of Compressed Gases in Cylinders," available from the Compressed Gas Association, 14501 George Carter Way Chantilly, VA 20151.



FOR ELECTRICALLY POWERED EQUIPMENT.



- 8.a. Turn off input power using the disconnect switch at the fuse box before working on the equipment.
- 8.b. Install equipment in accordance with the U.S. National Electrical Code, all local codes and the manufacturer's recommendations.
- 8.c. Ground the equipment in accordance with the U.S. National Electrical Code and the manufacturer's recommendations.

Refer to
<http://www.lincolnelectric.com/safety>
for additional safety information.

PRÉCAUTIONS DE SÛRETÉ

Pour votre propre protection lire et observer toutes les instructions et les précautions de sûreté spécifiques qui paraissent dans ce manuel aussi bien que les précautions de sûreté générales suivantes:

Sûreté Pour Soudage A L'Arc

1. Protégez-vous contre la secousse électrique:
 - a. Les circuits à l'électrode et à la pièce sont sous tension quand la machine à souder est en marche. Éviter toujours tout contact entre les parties sous tension et la peau nue ou les vêtements mouillés. Porter des gants secs et sans trous pour isoler les mains.
 - b. Faire très attention de bien s'isoler de la masse quand on soude dans des endroits humides, ou sur un plancher métallique ou des grilles métalliques, principalement dans les positions assis ou couché pour lesquelles une grande partie du corps peut être en contact avec la masse.
 - c. Maintenir le porte-électrode, la pince de masse, le câble de soudage et la machine à souder en bon et sûr état de fonctionnement.
 - d. Ne jamais plonger le porte-électrode dans l'eau pour le refroidir.
 - e. Ne jamais toucher simultanément les parties sous tension des porte-électrodes connectés à deux machines à souder parce que la tension entre les deux pinces peut être le total de la tension à vide des deux machines.
 - f. Si on utilise la machine à souder comme une source de courant pour soudage semi-automatique, ces précautions pour le porte-électrode s'appliquent aussi au pistolet de soudage.
2. Dans le cas de travail au dessus du niveau du sol, se protéger contre les chutes dans le cas où on recoit un choc. Ne jamais enrouler le câble-électrode autour de n'importe quelle partie du corps.
3. Un coup d'arc peut être plus sévère qu'un coup de soleil, donc:
 - a. Utiliser un bon masque avec un verre filtrant approprié ainsi qu'un verre blanc afin de se protéger les yeux du rayonnement de l'arc et des projections quand on soude ou quand on regarde l'arc.
 - b. Porter des vêtements convenables afin de protéger la peau de soudeur et des aides contre le rayonnement de l'arc.
 - c. Protéger l'autre personnel travaillant à proximité au soudage à l'aide d'écrans appropriés et non-inflammables.
4. Des gouttes de laitier en fusion sont émises de l'arc de soudage. Se protéger avec des vêtements de protection libres de l'huile, tels que les gants en cuir, chemise épaisse, pantalons sans revers, et chaussures montantes.
5. Toujours porter des lunettes de sécurité dans la zone de soudage. Utiliser des lunettes avec écrans latéraux dans les zones où l'on pique le laitier.
6. Eloigner les matériaux inflammables ou les recouvrir afin de prévenir tout risque d'incendie dû aux étincelles.
7. Quand on ne soude pas, poser la pince à un endroit isolé de la masse. Un court-circuit accidentel peut provoquer un échauffement et un risque d'incendie.
8. S'assurer que la masse est connectée le plus près possible de la zone de travail qu'il est pratique de le faire. Si on place la masse sur la charpente de la construction ou d'autres endroits éloignés de la zone de travail, on augmente le risque de voir passer le courant de soudage par les chaînes de levage, câbles de grue, ou autres circuits. Cela peut provoquer des risques d'incendie ou d'échauffement des chaînes et des câbles jusqu'à ce qu'ils se rompent.
9. Assurer une ventilation suffisante dans la zone de soudage. Ceci est particulièrement important pour le soudage de tôles galvanisées plombées, ou cadmiées ou tout autre métal qui produit des fumées toxiques.
10. Ne pas souder en présence de vapeurs de chlore provenant d'opérations de dégraissage, nettoyage ou pistolage. La chaleur ou les rayons de l'arc peuvent réagir avec les vapeurs du solvant pour produire du phosgène (gas fortement toxique) ou autres produits irritants.
11. Pour obtenir de plus amples renseignements sur la sûreté, voir le code "Code for safety in welding and cutting" CSA Standard W 117.2-1974.

PRÉCAUTIONS DE SÛRETÉ POUR LES MACHINES À SOUDER À TRANSFORMATEUR ET À REDRESSEUR

1. Relier à la terre le châssis du poste conformément au code de l'électricité et aux recommandations du fabricant. Le dispositif de montage ou la pièce à souder doit être branché à une bonne mise à la terre.
2. Autant que possible, l'installation et l'entretien du poste seront effectués par un électricien qualifié.
3. Avant de faire des travaux à l'intérieur de poste, la débrancher à l'interrupteur à la boîte de fusibles.
4. Garder tous les couvercles et dispositifs de sûreté à leur place.

Electromagnetic Compatibility (EMC)

Conformance

Products displaying the CE mark are in conformity with European Community Council Directive of 15 Dec 2004 on the approximation of the laws of the Member States relating to electromagnetic compatibility, 2004/108/EC. It was manufactured in conformity with a national standard that implements a harmonized standard: EN 60974-10 Electromagnetic Compatibility (EMC) Product Standard for Arc Welding Equipment. It is for use with other Lincoln Electric equipment. It is designed for industrial and professional use.

Introduction

All electrical equipment generates small amounts of electromagnetic emission. Electrical emission may be transmitted through power lines or radiated through space, similar to a radio transmitter. When emissions are received by other equipment, electrical interference may result. Electrical emissions may affect many kinds of electrical equipment; other nearby welding equipment, radio and TV reception, numerical controlled machines, telephone systems, computers, etc. Be aware that interference may result and extra precautions may be required when a welding power source is used in a domestic establishment.

Installation and Use

The user is responsible for installing and using the welding equipment according to the manufacturer's instructions. If electromagnetic disturbances are detected then it shall be the responsibility of the user of the welding equipment to resolve the situation with the technical assistance of the manufacturer. In some cases this remedial action may be as simple as earthing (grounding) the welding circuit, see Note. In other cases it could involve construction of an electromagnetic screen enclosing the power source and the work complete with associated input filters. In all cases electromagnetic disturbances must be reduced to the point where they are no longer troublesome.

Note: The welding circuit may or may not be earthed for safety reasons according to national codes. Changing the earthing arrangements should only be authorized by a person who is competent to access whether the changes will increase the risk of injury, e.g., by allowing parallel welding current return paths which may damage the earth circuits of other equipment.

Assessment of Area

Before installing welding equipment the user shall make an assessment of potential electromagnetic problems in the surrounding area. The following shall be taken into account:

- a) other supply cables, control cables, signaling and telephone cables; above, below and adjacent to the welding equipment;
- b) radio and television transmitters and receivers;
- c) computer and other control equipment;
- d) safety critical equipment, e.g., guarding of industrial equipment;
- e) the health of the people around, e.g., the use of pacemakers and hearing aids;
- f) equipment used for calibration or measurement
- g) the immunity of other equipment in the environment. The user shall ensure that other equipment being used in the environment is compatible. This may require additional protection measures;
- h) the time of day that welding or other activities are to be carried out.

Electromagnetic Compatibility (EMC)

The size of the surrounding area to be considered will depend on the structure of the building and other activities that are taking place. The surrounding area may extend beyond the boundaries of the premises.

Methods of Reducing Emissions

Mains Supply

Welding equipment should be connected to the mains supply according to the manufacturer's recommendations. If interference occurs, it may be necessary to take additional precautions such as filtering of the mains supply. Consideration should be given to shielding the supply cable of permanently installed welding equipment, in metallic conduit or equivalent. Shielding should be electrically continuous throughout its length. The shielding should be connected to the welding power source so that good electrical contact is maintained between the conduit and the welding power source enclosure.

Maintenance of the Welding Equipment

The welding equipment should be routinely maintained according to the manufacturer's recommendations. All access and service doors and covers should be closed and properly fastened when the welding equipment is in operation. The welding equipment should not be modified in any way except for those changes and adjustments covered in the manufacturer's instructions. In particular, the spark gaps of arc striking and stabilizing devices should be adjusted and maintained according to the manufacturer's recommendations.

Welding Cables

The welding cables should be kept as short as possible and should be positioned close together, running at or close to floor level.

Equipotential Bonding

Bonding of all metallic components in the welding installation and adjacent to it should be considered. However, metallic components bonded to the work piece will increase the risk that the operator could receive a shock by touching these metallic components and the electrode at the same time. The operator should be insulated from all such bonded metallic components.

Earthing of the Workpiece

Where the workpiece is not bonded to earth for electrical safety, not connected to earth because of its size and position, e.g., ships hull or building steelwork, a connection bonding the workpiece to earth may reduce emissions in some, but not all instances. Care should be taken to prevent the earthing of the workpiece increasing the risk of injury to users, or damage to other electrical equipment. Where necessary, the connection of the workpiece to earth should be made by a direct connection to the workpiece, but in some countries where direct connection is not permitted, the bonding should be achieved by suitable capacitance, selected according to national regulations.

Screening and Shielding

Selective screening and shielding of other cables and equipment in the surrounding area may alleviate problems of interference. Screening of the entire welding installation may be considered for special applications¹.

¹ Portions of the preceding text are contained in EN 60974-10: "Electromagnetic Compatibility (EMC) product standard for arc welding equipment."

	Page
Installation	Section A
Technical Specifications - POWER WAVE® i400	A-1, A-2
Safety Precautions	A-3
Location and Mounting	A-3
Environmental Considerations	A-3
Lifting	A-3
Stacking	A-3
Electromagnetic Compatibility	A-4
Input and Grounding Connections	A-4
Input Connection	A-4
Connection Diagrams and Systems	A-5,A-6
Fanuc R30iA Controller Mounting	A-7
Typical Integrated Systems (Single Arm)	A-8
Typical Stand Alone Systems (Single Arm)	A-9
Typical Master / Slave System (Dual Arm)	A-10
Typical F355i Retrofit (Single Arm)	A-11
Electrode and Work Connections, General Guidelines	A-12
Cable Inductance, and its Effects on Welding	A-13
Remote Sense Lead Connections	A-13,A-14
Sense Lead Diagrams of Circumferential Applications	A-15
Control Cable Connections	A-16
Common Equipment Connections	A-16,A-17
DeviceNet Configuration, Other Set-up Issues	A-17
Operation	Section B
Safety Precautions	B-1
Graphic Symbols	B-2
Product Description	B-3
Recommended Processes and Equipment	B-3
Recommended Processes	B-3
Process and Equipment Limitations	B-3
Case Front Controls	B-4, B-5
Case Back Controls	B-5
Internal Controls, Power Up Sequence	B-6
Duty Cycle	B-6
Basic Welding Controls	B-7
Constant Voltage Welding	B-7
Pulse Welding	B-8
Accessories	Section C
Optional Equipment	C-1
Factory Installed	C-1
Field Installed	C-1
Compatible Lincoln Equipment	C-1
Maintenance	Section D
Safety Precautions	D-1
Routine and Periodic Maintenance	D-1
Calibration Specification, Chassis Removal Procedure	D-1
Capacitor Discharge Procedure	D-2
Troubleshooting	Section E
How to use Troubleshooting Guide	E-1
Using the Status LED to Troubleshoot System Problems	E-2
Error Codes For POWER WAVE®	E-3, E-4
Troubleshooting Guide	E-5 thru E-14
Wiring Diagram	Section F-1
Dimension Print	Section F-2
Parts Lists	P-588

TECHNICAL SPECIFICATIONS - POWER WAVE® i400 (K2669-2, K2673-2)

JAPANESE POWER SOURCES - INPUT VOLTAGE AND CURRENT					
Model	Duty Cycle	Input Voltage \pm 10%	Input Amperes (incl. robot and aux. load)	Idle Power	Power Factor @ Rated Output
K2669-2 K2673-2 (Chassis Only)	40% rating	200/208 3 phase 50/60 Hz	66 (86)	475 Watts Max. (fan on)	.80
	60% rating		61 (81)		
	100% rating		50 (70)		

RATED OUTPUT			
Process	Duty Cycle	Volts at Rated Amperes	Amperes
GMAW GMAW-Pulse FCAW GTAW-DC	40%	35	420
	60%	34	400
	100%	31.5	350

RECOMMENDED INPUT WIRE AND FUSE SIZES ¹				
3 PHASE INPUT VOLTAGE 50/60Hz	Input Amperes (incl. robot and aux. load)	Type 75°C Copper Wire in Conduit AWG (mm ²)	COPPER GROUNDING CONDUCTOR AWG (mm ²)	Fuse (Super Lag) or Breaker Size ²
200/208 3	66 (86)	4 (25)	8 (10)	100

¹ Wire and Fuse Sizes based upon the U.S. National Electric Code and maximum output for 40°C (104°) ambient.

² Also called "inverse time" or "thermal/magnetic" circuit breakers; circuit breakers that have a delay in tripping action that decreases as the magnitude of current increases.

³ Japanese Model Codes 11536, 11536R.

PHYSICAL DIMENSIONS				
MODEL	HEIGHT	WIDTH	DEPTH	WEIGHT
K2669-2	22.7 in. (577 mm)	24.4 in. (620 mm)	21.5 in. (546 mm)	188 lbs. (85.5 kg.)
K2673-2	21.0 in. (533 mm)	22.6 in. (574 mm)	18.5 in. (470 mm)	126 lbs. (57.3 kg.)

TEMPERATURE RANGES	
OPERATING TEMPERATURE RANGE 14°F to 104°F (-10C to 40C)	STORAGE TEMPERATURE RANGE -40°F to 185°F (-40°C to 85°C)

TECHNICAL SPECIFICATIONS - POWER WAVE® i400 (K2669-2, K2673-2)

REGULATORY REQUIREMENTS (JAPANESE MODELS)			
MODEL	Standard	Enclosure Rating	Insulation Class
K2669-2 K2673-2 ³ (Chassis Only)	EN 60974-1 EN 50199	IP21S	Class F (155°C)

³ Chassis ratings applicable only when installed as a replacement in the POWER WAVE® i400 cabinet.

SAFETY PRECAUTIONS

Read this entire installation section before you start installation.

⚠ WARNING

ELECTRIC SHOCK can kill.



- Only qualified personnel should perform this installation.
- Turn the input power OFF at the disconnect switch or fuse box before working on this equipment. Turn off the input power to any other equipment connected to the welding system at the disconnect switch or fuse box before working on the equipment.

- Do not touch electrically hot parts.
- Always connect the POWER WAVE® grounding lug (located inside the reconnect input access door) to a proper safety (Earth) ground.

LOCATION AND MOUNTING

The POWER WAVE® i400 case is designed to support the Fanuc R30iA controller and op box (up to 300lbs), matching the controller's footprint and styling. Mounting is externally accessible for simplified integration. The flexibility of the POWER WAVE® i400 also allows it to be operated as a stand alone unit. In either case, bolting the unit to the floor or a suitable platform is recommended to provide maximum stability. The minimum recommended clearance for chassis removal is 26" (66cm) from the rear of the machine as viewed from the output studs. See the Chassis Removal Procedure for additional information.

⚠ CAUTION

- **DO NOT MOUNT OVER COMBUSTIBLE SURFACES.** Where there is a combustible surface directly under stationary or fixed electrical equipment, that surface shall be covered with a steel plate at least .06"(1.6mm) thick, which shall extend not less than 5.90"(150mm) beyond the equipment on all sides.

ENVIRONMENTAL CONSIDERATIONS

The POWER WAVE® i400 will operate in harsh environments. Even so, it is important that simple preventative measures are followed in order to assure long life and reliable operation.

- The POWER WAVE® i400 must be located where there is free circulation of clean air such that air movement in the louvered sections of the machine will not be restricted.

- Dirt and dust that can be drawn into the POWER WAVE® i400 should be kept to a minimum. The use of air filters on the air intake is not recommended because normal air flow may be restricted. Failure to observe these precautions can result in excessive operating temperatures and nuisance shutdown.
- Do not use the POWER WAVE® i400 in an outdoor environment. The power source should not be subjected to falling water, nor should any parts of it be submerged in water. Doing so may cause improper operation as well as pose a safety hazard. The best practice is to keep the machine in a dry, sheltered area.

LIFTING

⚠ WARNING

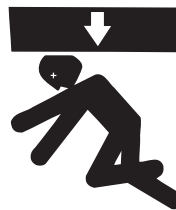

- Lift only with equipment of adequate lifting capacity.
- Be sure machine is stable when lifting.
- Do not lift this machine using lift bail if it is equipped with a heavy accessory such as trailer or gas cylinder.

- FALLING EQUIPMENT can cause injury.**
- Do not lift machine if lift bail is damaged.
 - Do not operate machine while suspended from lift bail.

POWER WAVE® i400: Lift the machine by the corner mounted lift bails only. Do not attempt to lift the POWER WAVE® i400 with accessories attached to it.

POWER WAVE® i400 with the Fanuc R30iA Controller: When properly mounted the complete integrated unit (power source and controller) can be lifted using the lift hooks provided on the Fanuc R30iA controller. Consult the Fanuc instruction manual for details and precautions.

NOTE: The POWER WAVE® i400 external corner mounted lift bales must be removed when mounted to the Fanuc R30iA controller.

POWER WAVE® i400 Replacement Chassis: Lift the chassis by the lift bail on top of the harmonic filter assembly.

STACKING

The POWER WAVE® i400 cannot be stacked.

POWER WAVE® i400



ELECTROMAGNETIC COMPATIBILITY (EMC)

The EMC classification of the POWER WAVE® i400 is Industrial, Scientific and Medical (ISM) group 2, class A. The POWER WAVE® i400 is for industrial use only. (See prints L10093-1, -2 Safety Pages in the front of Instruction Manual for further details).

Locate the POWER WAVE® i400 away from radio controlled machinery. The normal operation of the POWER WAVE® i400 may adversely affect the operation of RF controlled equipment, which may result in bodily injury or damage to the equipment.

INPUT AND GROUNDING CONNECTIONS

MACHINE GROUNDING

The frame of the welder must be  grounded. A ground terminal marked with the symbol shown is located inside the reconnect/input access door for this purpose. See your local and national electrical codes for proper grounding methods.

INPUT CONNECTIONS



WARNING



ELECTRIC SHOCK can kill.

- Only a qualified electrician should connect the input leads to the POWER WAVE®. Connections should be made in accordance with all local and National Electrical Codes and the connection diagram located on the inside of the reconnect / input access door of the machine. Failure to do so may result in bodily injury or death.

Use a three-phase supply line. A 1.75 inch (45 mm) diameter access hole for the input supply is located on the case back. Connect L1, L2, L3 and ground according to the input supply and ground connection decals located near the input power terminal block (1TB) and ground block inside of the rear input reconnect box.

Input Fuse and Supply Wire Considerations

Refer to Specification in Installation Section for recommended fuse, wire sizes and type of the copper wires. Fuse the input circuit with the recommended super lag fuse or delay type breakers (also called "inverse time" or "thermal/magnetic" circuit breakers).

Choose input and grounding wire size according to local or national electrical codes. Using input wire sizes, fuses or circuit breakers smaller than recommended may result in "nuisance" shut-offs from welder inrush currents, even if the machine is not being used at high currents.

Power Supply Connection for the Fanuc R30iA Controller

The POWER WAVE® i400 is equipped with a dedicated robot power terminal block (4TB) specifically designed to feed input power directly to the Fanuc R30iA controller through the power source rotary ON/OFF switch. The K2677-1 Integration kit provides the proper cable and installations instructions to make this connection.



WARNING

The POWER WAVE® i400 on/off switch is not intended as a service disconnect for this equipment. Only a qualified electrician should connect the input leads to the POWER WAVE®. Connections should be made in accordance with all local and national electrical codes and the connection diagram located on the inside of the reconnect access door of the machine. Failure to do so may result in bodily injury or death.

Do not attempt to back feed input power though the robot power terminal block (4TB) into the POWER WAVE® i400. This is not its intended purpose and may result in machine damage, bodily injury or death.

CONNECTION DIAGRAMS AND SYSTEM

RECOMMENDED EQUIPMENT

System Identifier	Part No.	Description
Power Source	K2669-1	POWER WAVE® i400 Power Source (includes S26064 POWER WAVE® Utilities CD)
Integration Kit	K2677-1	Integration Kit for Fanuc R30iA Controller. Includes industrial ethernet cable, power cable, protective grommets, mounting plate, and dust proof strain relief.
Wire Drive	K2685-2	AutoDrive 4R90 Wire Drive
Power Source to Wire Drive Control Cable	K1785-xx ¹	Feeder Control Cable (14 pin).
Weld Cables	K2163-xx -or- K1842-xx	Welding Power Cables Power Source to Wire Drive, and Power Source to Work K2163 Series cables sold in pairs. K1842 Series cables sold individually. See Price Book for details and bulk cable availability.
Robot Arm	Kxxxx	Consult Automation Division
Robot Controller	Kxxxx	
Torch	Kxxxx	

¹ Maximum length 100 ft.(30.5 m) Cannot be connected end to end.

OPTIONAL EQUIPMENT

System Identifier	Part No.	Description
Sense Lead Kit	K940-xx	Remote Sense Lead Kit. Recommended for sensitive or critical applications to more accurately monitor the arc voltage.
DeviceNet Kit	K2780-1	DeviceNet Kit. Allows Power Wave i400 to communicate via DeviceNet protocol.
Sync-Tandem Kit	K2781-1	Sync-Tandem Kit. Allows two Power Wave i400s to perform synchronized tandem pulse welding. Includes all necessary harnesses and cabling for 2 machines. Also provides access to special Sync-Tandem welding software.
ArcLink Digital Communication Cable	K1543-xx ² K2683-xx ²	ArcLink Control Cable (5 pin). Required for earlier controllers communicating via traditional ArcLink® over a standard 2 wire CAN based network. K2683 Recommended on Sever Duty application.
External Ethernet Network Equipment	Consult Automation Division	Ethernet Switch, Cables, etc. Required for external Ethernet system connectivity typically associated with multiple arm or multiple power source applications.
DeviceNet Cables and Accessories	Customer Supplied	DeviceNet Cables, Tees, and Terminators (5 pin sealed "mini style") Typically required for PLC or earlier model controllers communicating via DeviceNet. For additional information refer to the "DeviceNet Cable Planning and Installation Manual" (Allen Bradley publication DN-6.7.2).

² Cables can be connected end to end to extend length (recommended maximum 200 ft [61.0m]).

OPTIONAL EQUIPMENT

System Identifier	Part No.	Description
Coaxial Weld Cable	K1796-xx K2593-xx	Coax Cable. Recommended to minimize the effects of the weld cable loop inductance and maximize performance in critical high speed pulse applications. Note: K1796 coaxial cable is equivalent to 1/0 standard cable. K2539 coaxial cable is equivalent to AWG #1 standard cable. Connecting coaxial cables in parallel to increase current carrying capacity can significantly reduce their inductance minimizing properties, and is therefore NOT RECOMMENDED. Consult the Output Cable Guidelines for further information.
External Dress Cable for Robot Arm	K2709-xx	External Dress Cable. Heavy duty externally mounted 14pin wire feeder cable for use with robot arms not equipped with an integral cable.
Personal Computer	Customer Supplied	IBM Compatible PC (Windows NT SP6, Windows 2000, Windows XP, or greater) required for use with all POWER WAVE® Utilities
Replacement Chassis	K2673-2	POWER WAVE® i400 Replacement Chassis. Complete inverter power section. Intended only as a replacement to be installed in the POWER WAVE® i400 cabinet (includes S26064 POWER WAVE® Utilities CD).

FANUC R30iA CONTROLLER MOUNTING

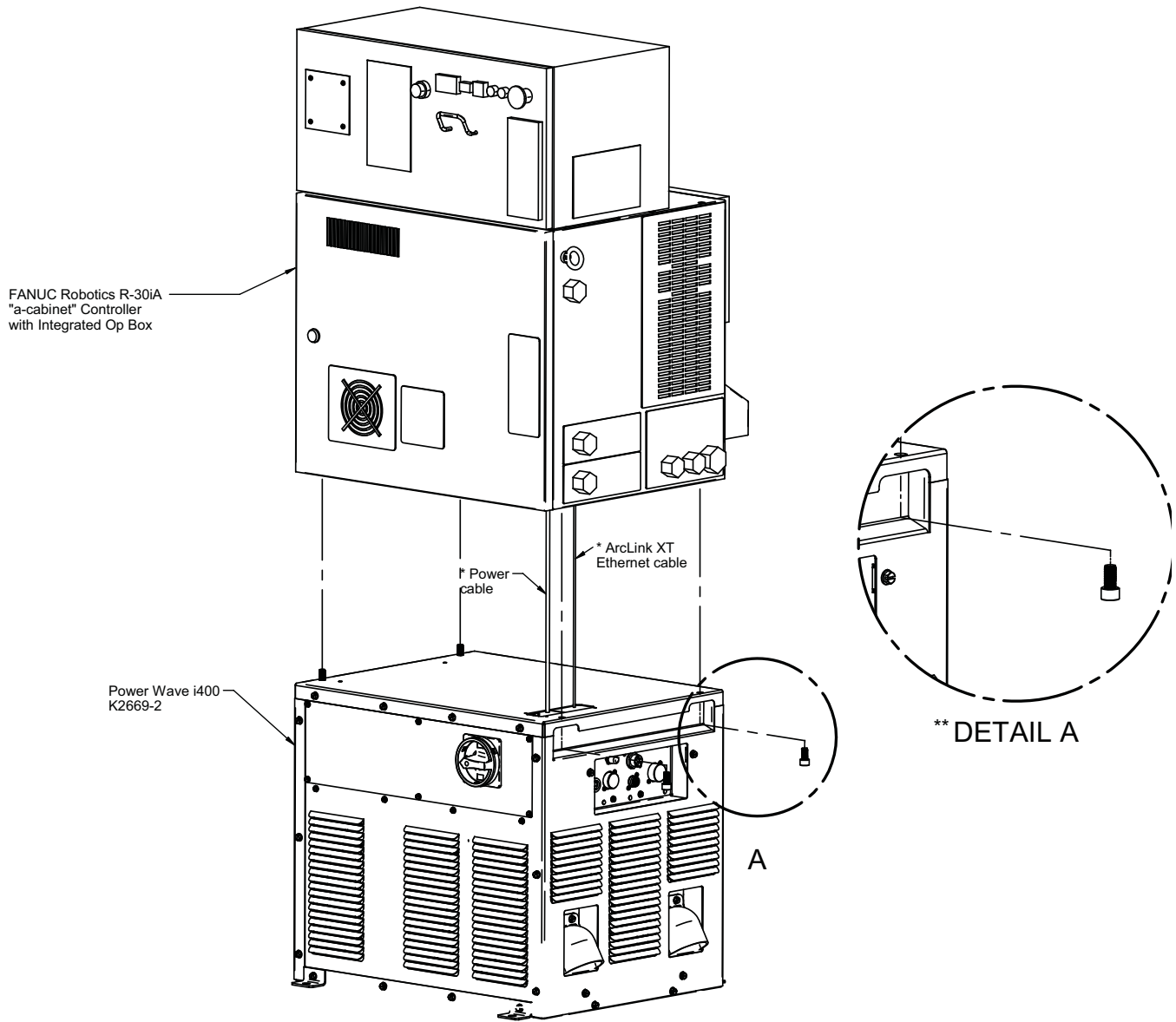

* Refer to Output Cable guidelines for recommended cable size in PowerWave® i400 Instruction Manual.

** Refer to Intergration kit K2677-1 instruction sheet

TYPICAL INTEGRATED SYSTEMS (SINGLE ARM)

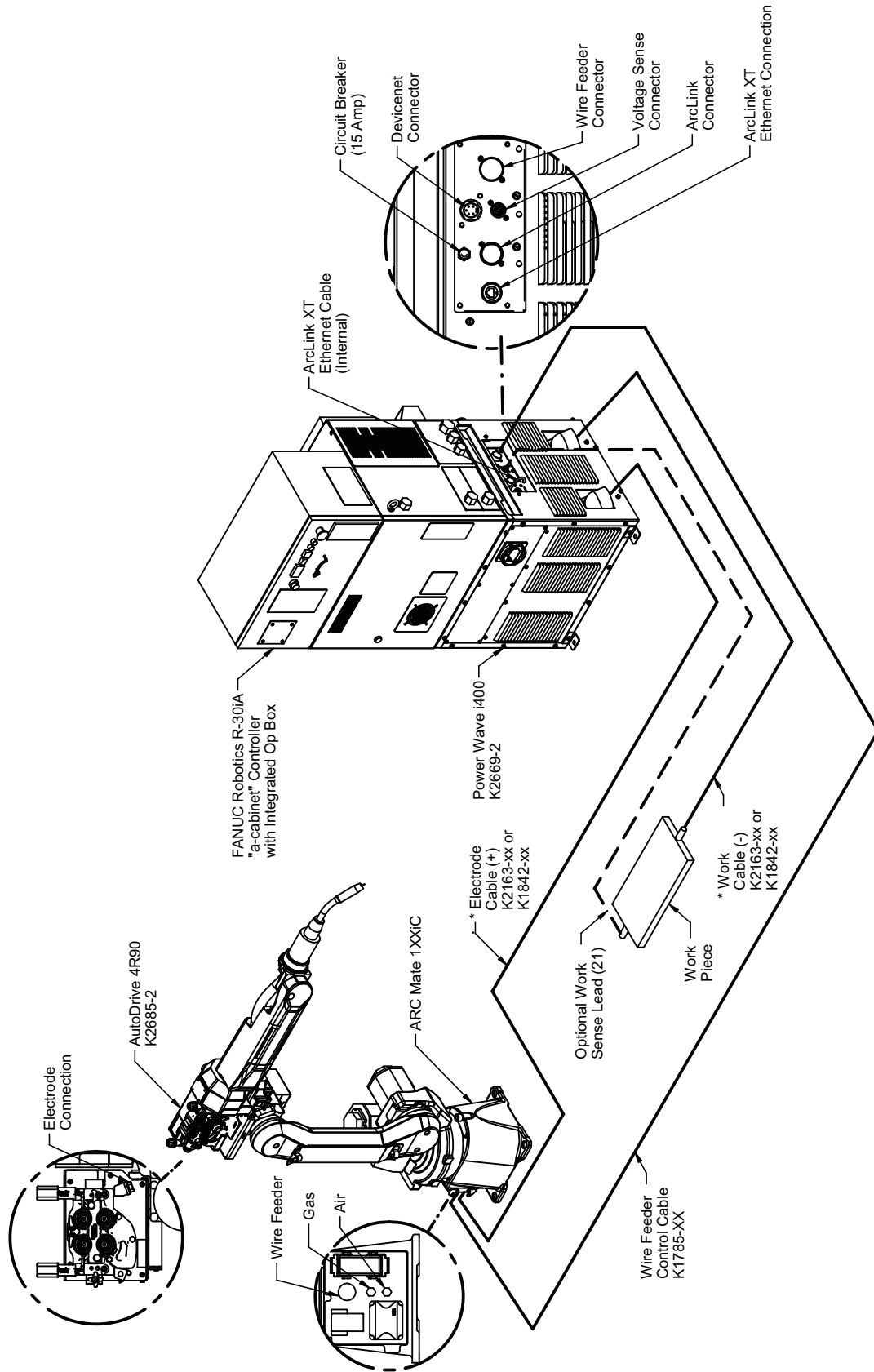

* Refer to Output Cable Guidelines for recommended cable size in PowerWave i400 Instruction Manual.

POWER WAVE® i400



TYPICAL STAND ALONE SYSTEMS (SINGLE ARM)

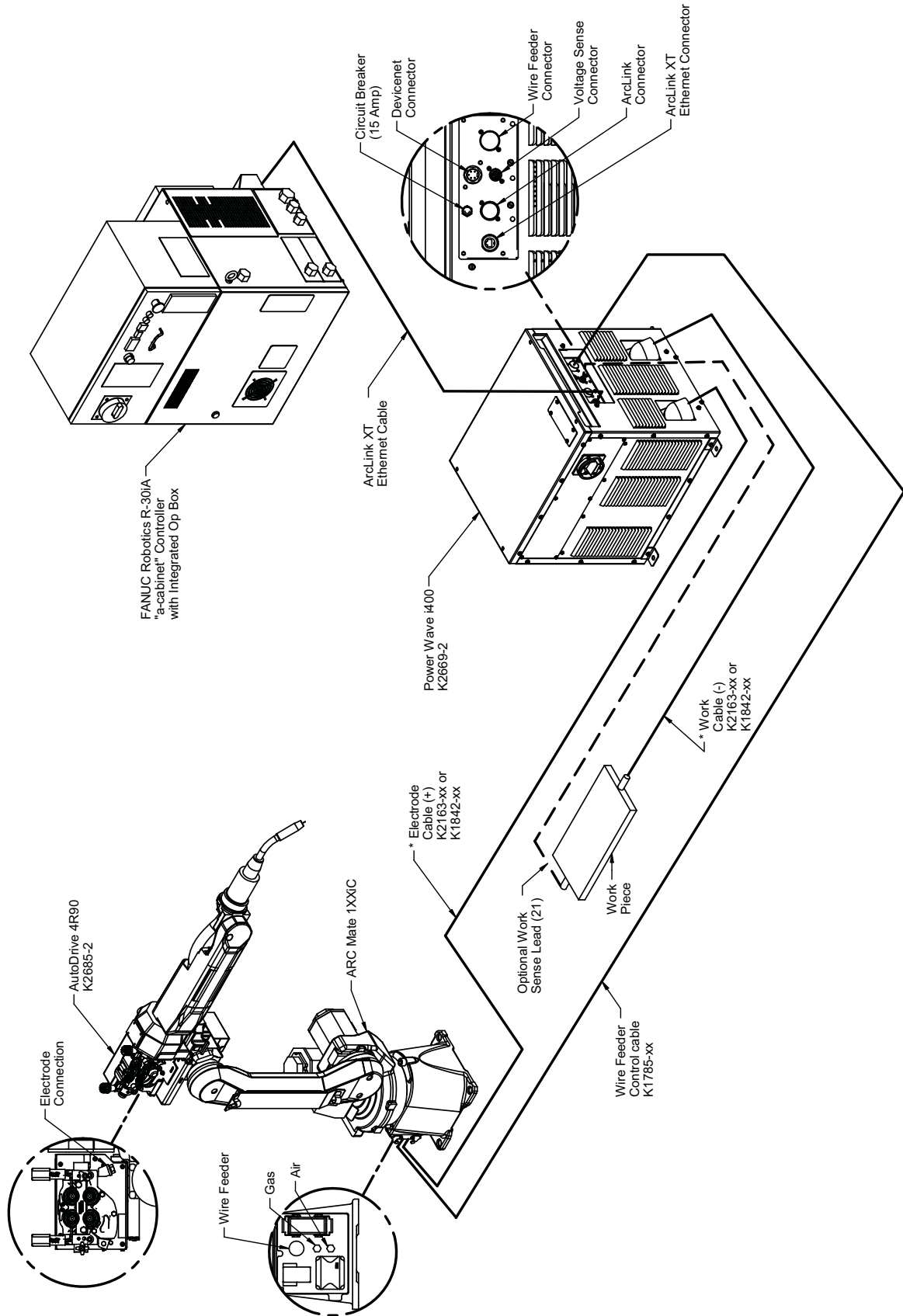

* Refer to Output Cable guidelines for recommended cable size in PowerWave® i400 Instruction Manual.

TYPICAL MASTER / SLAVE SYSTEM (DUAL ARM)

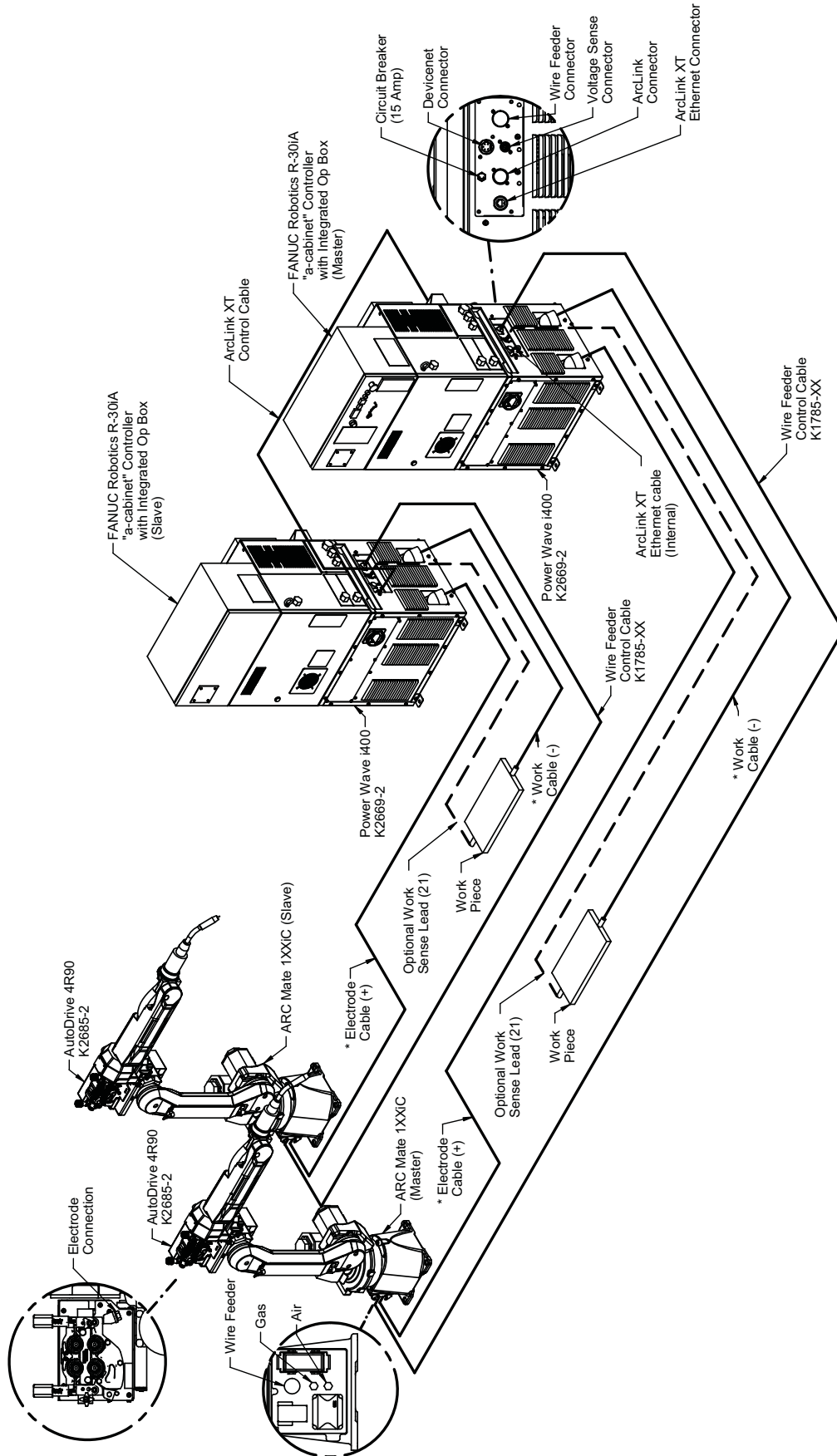

* Refer to Output Cable Guidelines for recommended cable size in PowerWave® i400 Instruction Manual.

POWER WAVE® i400



TYPICAL F355i RETROFIT (SINGLE ARM)

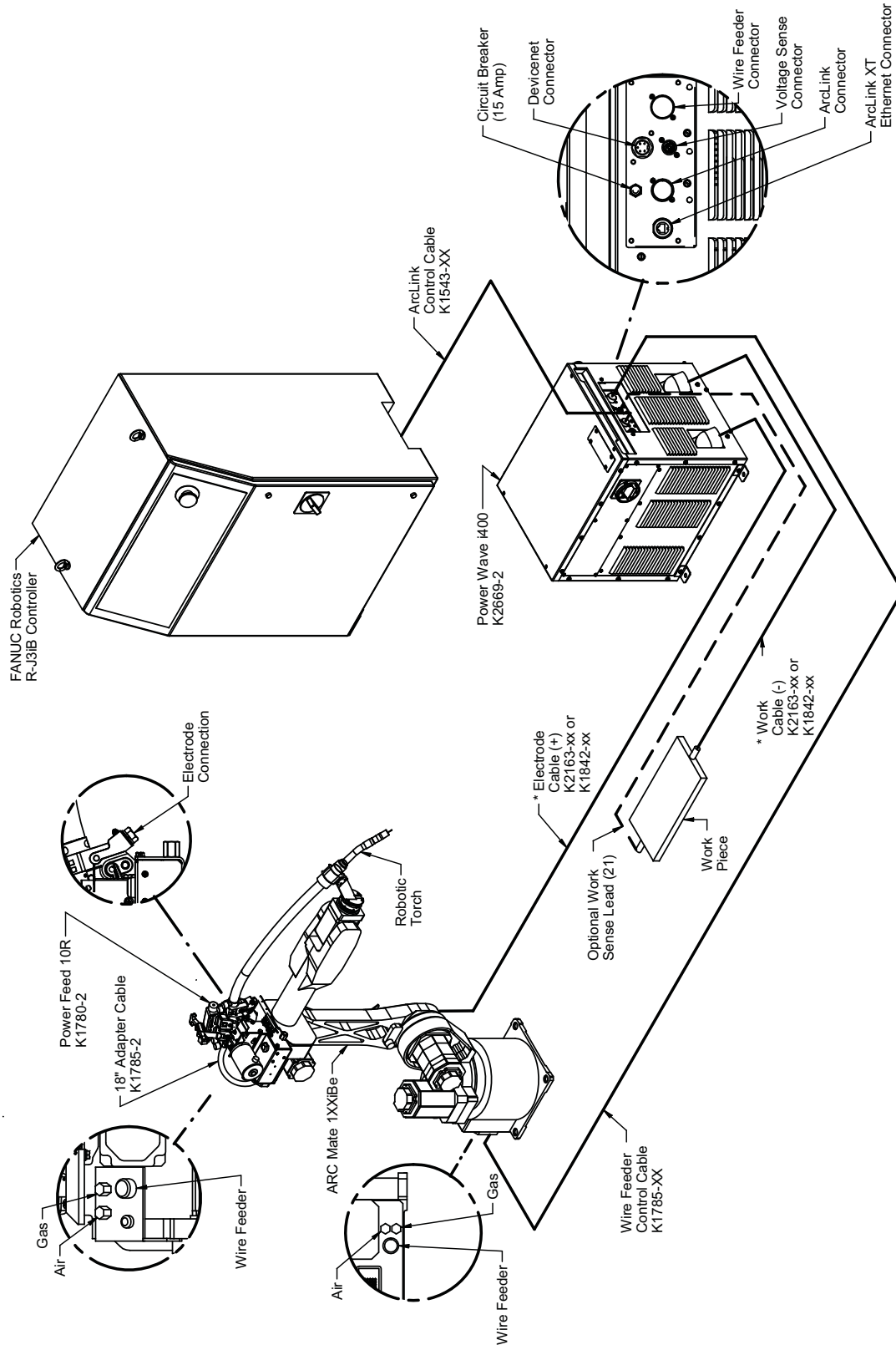

* Refer to Output Cable Guidelines for recommended cable size in PowerWave® i400 Instruction manual.

ELECTRODE AND WORK CONNECTIONS

Connect the electrode and work cables between the appropriate output studs of the POWER WAVE® i400 and the robot weld cell per the connection diagrams included in this document. Size and route the cables per the following.

- Most welding applications run with the electrode being positive (+). For those applications, connect the electrode cable between the wire drive feed plate and the positive (+) output stud on the power source. Connect a work lead from the negative (-) power source output stud to the work piece.
- When negative electrode polarity is required, such as in some Innershield applications, reverse the output connections at the power source (electrode cable to the negative (-) stud, and work cable to the positive (+) stud).

**CAUTION**

Negative electrode polarity operation WITHOUT use of a remote work sense lead (21) requires the Negative Electrode Polarity attribute to be set. See the Remote Sense Lead Specification section of this document for further details.

For additional Safety information regarding the electrode and work cable set-up, See the standard "SAFETY INFORMATION" located in the front of this Instruction Manual.

GENERAL GUIDELINES

- **Select the appropriate size cables per the "Output Cable Guidelines" in Table A.1.** Excessive voltage drops caused by undersized welding cables and poor connections often result in unsatisfactory welding performance. Always use the largest welding cables (electrode and work) that are practical, and be sure all connections are clean and tight.

Note: Excessive heat in the weld circuit indicates undersized cables and/or bad connections.

- **Route all cables directly to the work and wire feeder, avoid excessive lengths and do not coil excess cable.** Route the electrode and work cables in close proximity to one another to minimize the loop area and therefore the inductance of the weld circuit.

- **Always weld in a direction away from the work (ground) connection.**

In **Table A.1** are copper cable sizes recommended for different currents and duty cycles. Lengths stipulated are the distance from the welder to work and back to the welder again. Cable sizes are increased for greater lengths primarily for the purpose of minimizing cable drop.

TABLE A.1

OUTPUT CABLE GUIDELINES

Amperes	Percent Duty Cycle	CABLE SIZES FOR COMBINED LENGTHS OF ELECTRODE AND WORK CABLES (RUBBER COVERED COPPER - RATED 75°C)**				
		0 to 50 Ft.	50 to 100 Ft.	100 to 150 Ft.	150 to 200 Ft.	200 to 250 Ft.
200	60	2	2	2	1	1/0
200	100	2	2	2	1	1/0
225	20	4 or 5	3	2	1	1/0
225	40 & 30	3	3	2	1	1/0
250	30	3	3	2	1	1/0
250	40	2	2	1	1	1/0
250	60	1	1	1	1	1/0
250	100	1	1	1	1	1/0
300	60	1	1	1	1/0	2/0
325	100	2/0	2/0	2/0	2/0	3/0
350	60	1/0	1/0	2/0	2/0	3/0
400	60	2/0	2/0	2/0	3/0	4/0
400	100	3/0	3/0	3/0	3/0	4/0
500	60	2/0	2/0	3/0	3/0	4/0

** Tabled values are for operation at ambient temperatures of 40°C and below. Applications above 40°C may require cables larger than recommended, or cables rated higher than 75°C.

CABLE INDUCTANCE, AND ITS EFFECTS ON WELDING

Excessive cable inductance will cause the welding performance to degrade. There are several factors that contribute to the overall inductance of the cabling system including cable size, and loop area. The loop area is defined by the separation distance between the electrode and work cables, and the overall welding loop length. The welding loop length is defined as the total of length of the electrode cable (A) + work cable (B) + work path (C) (see Figure A.2). To minimize inductance always use the appropriate size cables, and whenever possible, run the electrode and work cables in close proximity to one another to minimize the loop area. Since the most significant factor in cable inductance is the welding loop length, avoid excessive lengths and do not coil excess cable. For long work piece lengths, a sliding ground should be considered to keep the total welding loop length as short as possible.

FIGURE A.2

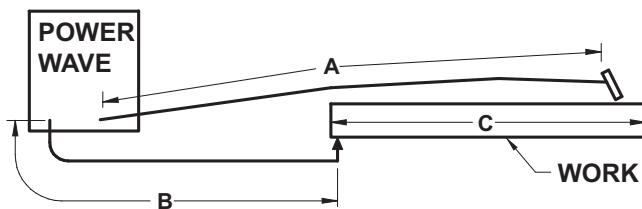

REMOTE SENSE LEAD CONNECTIONS

Voltage Sensing Overview

The best arc performance occurs when the POWER WAVE® i400 has accurate data about the arc conditions. Depending upon the process, inductance within the electrode and work cables can influence the voltage apparent at the studs of the welder, and have a dramatic effect on performance. Remote voltage sense leads are used to improve the accuracy of the arc voltage information supplied to the control pc board. Sense Lead Kits (K940-xx) are available for this purpose.

⚠ CAUTION

If the remote voltage sensing is enabled but the sense leads are missing, improperly connected, or if the electrode polarity attribute is improperly configured extremely high welding outputs may occur.

General Guidelines for Voltage Sense Leads

Sense leads should be attached as close to the weld as practical, and out of the weld current path when possible. In extremely sensitive applications it may be necessary to route cables that contain the sense leads away from the electrode and work welding cables.

Voltage sense leads requirements are based on the weld process as follows:

TABLE A.2

Process	Electrode Voltage Sensing (67 lead) ¹	Work Voltage Sensing (21 lead) ²
GMAW	67 lead required	21 lead optional ³
GMAW-P	67 lead required	21 lead optional ³
FCAW	67 lead required	21 lead optional ³
GTAW	Voltage sense at studs	Voltage sense at studs

- ¹ The electrode voltage sense lead (67) is automatically enabled by the weld process, and integral to the 14 pin wire feeder control cable (K1785).
- ² The work voltage sense lead (21) is manually enabled, but overridden by constant current weld processes defined for stud sensing.
- ³ Negative polarity semi-automatic process operation WITHOUT use of a remote work sense lead (21) requires the Negative Electrode Polarity attribute to be set. This establishes which output stud the electrode voltage sense lead (67) will be referenced to.

Electrode Voltage Sensing

The remote ELECTRODE sense lead (67) is built into the standard wire feeder control cable (K1785) and is always connected to the wire drive feed plate when a wire feeder is present. Enabling or disabling electrode voltage sensing is application specific, and automatically configured by the active weld mode.

The remote ELECTRODE sense lead (67) is also available in the remote Voltage Sense Connector for applications that do not use the standard wire feeder control cable (K1785). This can be easily accessed with the optional K940 Sense Lead kit.

Work Voltage Sensing

The POWER WAVE® i400 is configured at the factory to sense work voltage at the negative output stud (positive output polarity with remote Work Voltage Sensing disabled).

CAUTION

Negative electrode polarity operation **WITHOUT** use of a remote work sense lead (21) requires the **Negative Electrode Polarity** attribute to be set via the **Fanuc Teach Pendant** or with the **Weld Manager Utility** (included on the **Power Wave Utilities and Service Navigator CD's** or available at www.powerwavesoftware.com).

While most applications perform adequately by sensing the work voltage directly at the output stud, the use of a remote work voltage sense lead is recommended for optimal performance. The remote WORK sense lead (21) can be accessed through the four-pin voltage sense connector located on the control panel by using the K940 Sense Lead Kit. It must be attached to the work as close to the weld as practical, but out of the weld current path. For more information regarding the placement of remote work voltage sense leads, see the section entitled "Voltage Sensing Considerations for Multiple Arc Systems."

WARNING

If a remote work voltage sense lead is used, it **must be enabled** through the **Fanuc Teach Pendant** or with the **Weld Manager Utility** (included on the **Power Wave Utilities and Service Navigator CD's** or available at www.powerwavesoftware.com).

Voltage Sensing Considerations for Multiple Arc Systems

Special care must be taken when more than one arc is welding simultaneously on a single part. Multiple arc applications do not necessarily dictate the use of remote work voltage sense leads, but they are strongly recommended.

If Sense Leads ARE NOT Used:

- Avoid common current paths. Current from adjacent arcs can induce voltage into each others current paths that can be misinterpreted by the power sources, and result in arc interference.

If Sense Leads ARE Used:

- **Position the sense leads out of the path of the weld current.** Especially any current paths common to adjacent arcs. Current from adjacent arcs can induce voltage into each others current paths that can be misinterpreted by the power sources, and result in arc interference.

- **For longitudinal applications,** connect all work leads at one end of the weldment, and all of the work voltage sense leads at the opposite end of the weldment. Perform welding in the direction away from the work leads and toward the sense leads.

(See Figure A.3)

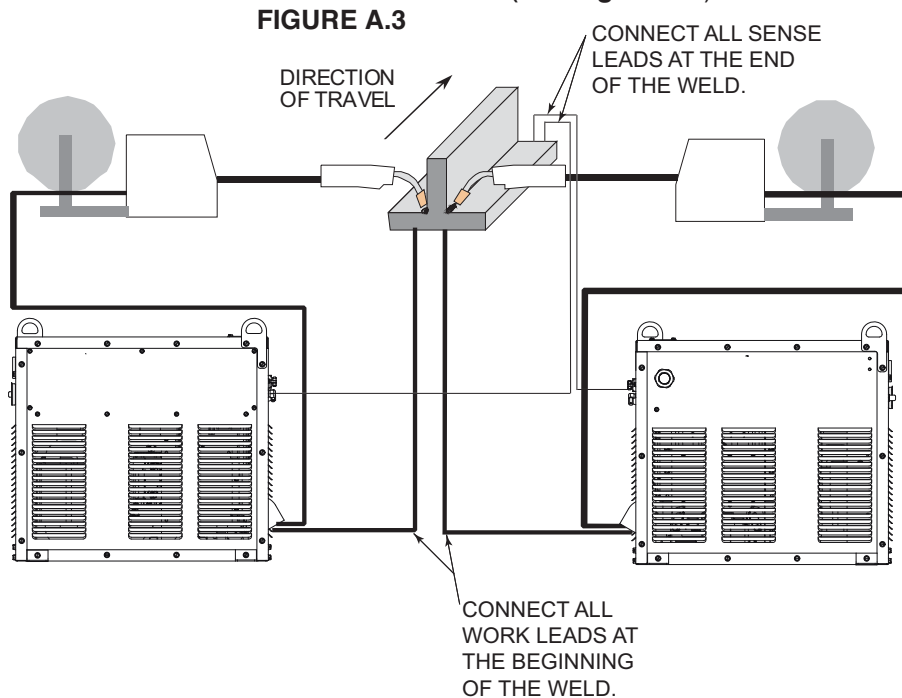

POWER WAVE® i400

- For circumferential applications, connect all work leads on one side of the weld joint, and all of the work voltage sense leads on the opposite side, such that they are out of the current path.

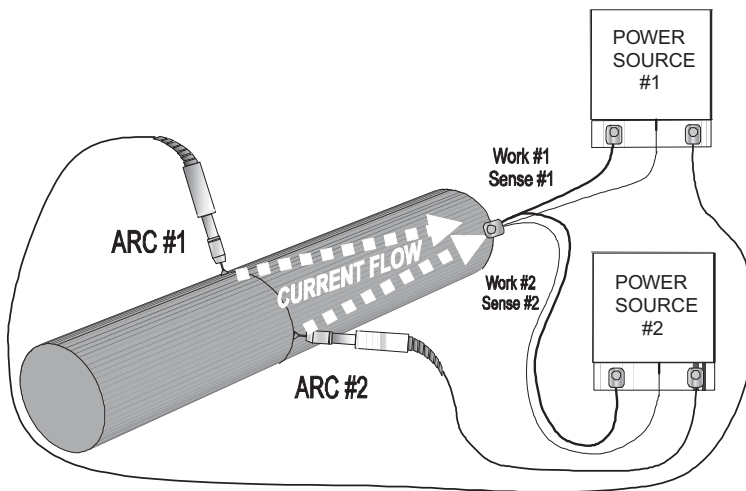

BAD

- CURRENT FLOW FROM ARC #1 AFFECTS SENSE LEAD #2
- CURRENT FLOW FROM ARC #2 AFFECTS SENSE LEAD #1
- NEITHER SENSE LEAD PICKS UP THE CORRECT WORK VOLTAGE, CAUSING STARTING AND WELDING ARC INSTABILITY

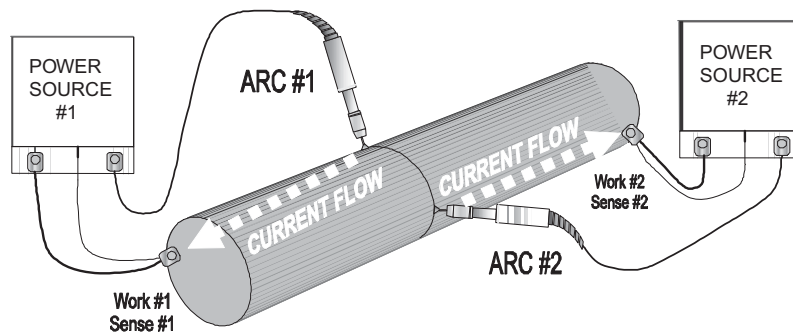

BETTER

- SENSE LEAD #1 IS ONLY AFFECTED BY CURRENT FLOW FROM ARC #1
- SENSE LEAD #2 IS ONLY AFFECTED BY CURRENT FLOW FROM ARC #2
- DUE TO VOLTAGE DROPS ACROSS THE WORKPIECE ARC VOLTAGE MAY BE LOW, CAUSING NEED FOR DEVIATION FROM STANDARD PROCEDURES

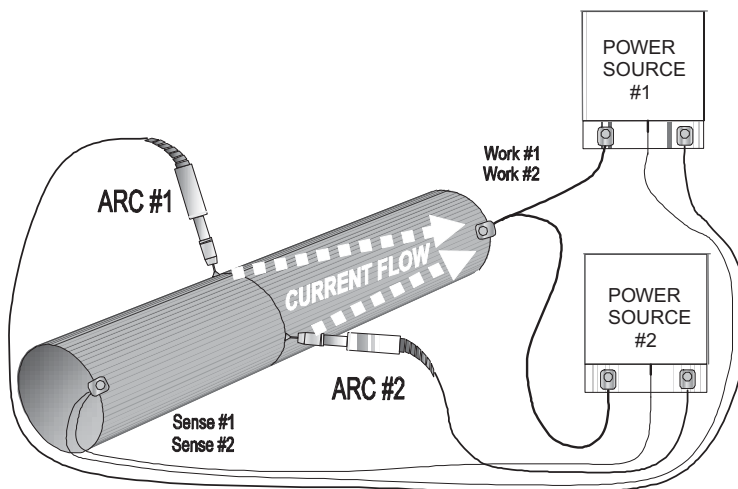

BEST

- BOTH SENSE LEADS ARE OUT OF THE CURRENT PATHS
- BOTH SENSE LEADS DETECT ARC VOLTAGE ACCURATELY
- NO VOLTAGE DROP BETWEEN ARC AND SENSE LEAD
- BEST STARTS, BEST ARCS, MOST RELIABLE RESULTS

CONTROL CABLE CONNECTIONS

General Guidelines

Genuine Lincoln control cables should be used at all times (except where noted otherwise). Lincoln cables are specifically designed for the communication and power needs of the POWER WAVE® / Power Feed systems. Most are designed to be connected end to end for ease of extension. Generally, it is recommended that the total length not exceed 100 ft. (30.5 m). The use of non-standard cables, especially in lengths greater than 25 ft. (7.6 m), can lead to communication problems (system shutdowns), poor motor acceleration (poor arc starting), and low wire driving force (wire feeding problems). Always use the shortest length of control cable possible, and DO NOT coil excess cable.

Regarding cable placement, best results will be

CAUTION

obtained when control cables are routed separate from the weld cables. This minimizes the possibility of interference between the high currents flowing through the weld cables, and the low level signals in the control cables. These recommendations apply to all communication cables including ArcLink® and Ethernet connections.

COMMON EQUIPMENT CONNECTIONS

Connection Between Power Source and Wire Feeder (K1785 or K2709 Control Cable)

The 14 pin wire feeder control cable connects the power source to the wire drive. It contains all of the necessary signals to drive the motor and monitor the arc, including the motor power, tachometer, and arc voltage feedback signals. The wire feeder connection on the POWER WAVE® i400 is located on the recessed control panel above the output studs. Fanuc robot arms are equipped with internal cabling and provide a standard 14 pin MS-style connection at the base of the robot, and near the wire feeder mount at the top of the arm. The K2709 series external dress cable is recommended for severe duty applications such as hard automation or for robot arms not equipped with an internal control cable. Best results will be obtained when control cables are routed separate from the weld cables, especially in long distance applications. Maximum cable length should not exceed 100ft(30.5m).

Connection Between Power Source and ArcLink®XT Compatible Controllers or Ethernet Networks. Newer model controllers, such as the Fanuc R30iA, communicate via ArcLink®XT over an industrial Ethernet connection. To facilitate this, the Power Wave i400 is equipped with an IP67 rated ODVA compliant RJ-45 Ethernet connector, which is located on the recessed control panel above the output studs. A special access chute is provided above the Ethernet connection on the Power Wave i400 to accommodate seamless integration with the Fanuc R30iA controller. The K2677-1 Integration Kit includes a specially designed industrial rated Ethernet cable for this purpose.

It is highly recommended that all external Ethernet equipment (cables, switches, etc.), as defined by the connection diagrams, be obtained through the Lincoln Electric Automation Division. It is critical that all Ethernet cables external to either a conduit or an enclosure are solid conductor, shielded cat 5e cable, with a drain. The drain should be grounded at the source of transmission, such as a network switch or the Fanuc R30iA ground strip. Ethernet cables will achieve optimal performance levels at distances up to 25 feet. Special attention to layout may be required to support distances greater than 25 feet, including specialized network equipment. For best results, always route Ethernet cables away from weld cables, wire drive control cables, or any other current carrying device that can create a fluctuating magnetic field. For additional guidelines refer to industry standard documents for industrial Ethernet networks. Failure to follow these recommendations can result in an Ethernet connection failure during welding.

The ethernet port of the Power Wave i400 is factory configured with a dynamic IP address. This is required for seamless operation with the Fanuc R30iA controller.

Connection Between Power Source and ArcLink® Compatible Controllers (K1543 or K2683 ArcLink Control Cable)

Earlier model Fanuc controllers communicate via traditional ArcLink® over a standard 2 wire CAN based network. In these systems, the 5 pin ArcLink control cable connects the power source to the controller.

The control cable consists of two power leads, one twisted pair for digital communication, and one lead for voltage sensing. The sense leads and power leads are typically unused in this application. The 5 pin ArcLink connection on the POWER WAVE® i400 is located on the recessed control panel above the output studs. The control cable is keyed and polarized to prevent improper connection. Best results will be obtained when control cables are routed separate from the weld cables, especially in long distance applications. The recommended combined length of the ArcLink control cable network should not exceed 200ft(61.0m).

Connections Between Power Source and Optional DeviceNet PLC Controller. Hard Automation applications and some earlier model controllers may require DeviceNet connectivity to control the power source. DeviceNet can also be used to monitor welding data, and system status information. The optional K2780-1 DeviceNet Kit is available for this purpose. It includes a 5 pin DeviceNet sealed mini style receptacle that mounts on the recessed control panel of the Power Wave i400, above the output studs. The DeviceNet cable is keyed and polarized to prevent improper connection. For best results, route DeviceNet cables away from weld cables, wire drive control cables, or any other current carrying device that can create a fluctuating magnetic field. DeviceNet cables must be sourced locally by the customer. For additional guidelines refer to the “DeviceNet Cable Planning and Installation Manual” (Allen Bradley publication DN-6.7.2).

The DeviceNet MAC ID and baud rate of the POWER WAVE® i400 can be configured with the Diagnostics Utility (included on the POWER WAVE® Utilities and Service Navigator CD's or available at www.powerwavesoftware.com).

OTHER SET-UP ISSUES

Selecting a Wire Drive and Setting the Wire Drive Gear Ratio. The POWER WAVE® i400 can accommodate a number of standard wire drives including the AutoDrive 4R90 (default) and PF-10R. The feeder control system must be configured for both the wire drive type and gear ratio (high or low speed range). This can be accomplished via the **Fanuc Teach Pendant** (V7.30p14 or later) or with the Weld Manager Utility (included on the Power Wave Utilities and Service Navigator CD's or available at www.powerwavesoftware.com).

Additional information is also available in the “How To” section at www.powerwavesoftware.com.

SAFETY PRECAUTIONS

Read this entire section of operating instructions before operating the machine.



WARNING

ELECTRIC SHOCK can kill.



- Unless using cold feed feature, when feeding with gun trigger, the electrode and drive mechanism are always electrically energized and could remain energized several seconds after the welding ceases.
- Do not touch electrically live parts or electrodes with your skin or wet clothing.
- Insulate yourself from the work and ground.
- Always wear dry insulating gloves.

FUMES AND GASES can be dangerous.



- Keep your head out of fumes.
- Use ventilation or exhaust to remove fumes from breathing zone.

WELDING SPARKS can cause fire or explosion.

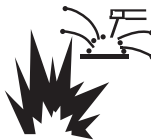

- Keep flammable material away.
- Do not weld on containers that have held combustibles.

















ARC RAYS can burn.



- Wear eye, ear, and body protection.

Observe additional guidelines detailed in the beginning of this manual.

GRAPHIC SYMBOLS THAT APPEAR ON THIS MACHINE OR IN THIS MANUAL

	INPUT POWER		
	ON	U_0	OPEN CIRCUIT VOLTAGE
	OFF	U_1	INPUT VOLTAGE
	HIGH TEMPERATURE	U_2	OUTPUT VOLTAGE
	MACHINE STATUS	I_1	INPUT CURRENT
	CIRCUIT BREAKER	I_2	OUTPUT CURRENT
	WIRE FEEDER		PROTECTIVE GROUND
	POSITIVE OUTPUT		
	NEGATIVE OUTPUT		WARNING or CAUTION
	3 PHASE INVERTER		Explosion
	INPUT POWER		Dangerous Voltage
$3 \sim$	THREE PHASE		Shock Hazard
	DIRECT CURRENT		

PRODUCT DESCRIPTION

PRODUCT SUMMARY

General Physical Description

The POWER WAVE® i400 is intended as a replacement for the PW355i using an updated power and control platform to enhance performance and reliability. The POWER WAVE® i400 includes an integrated wire drive module and 14-pin MS-Style connection to support the PF-10R and Auto Drive 4R90. ArcLink® communication is supported through the 5 pin MS-style interface. The new ArcLink®XT communication protocol is supported through an RJ-45 type Ethernet connection, which also provides access for the POWER WAVE® Utilities software tools. In addition, the DeviceNet communication protocol is supported by a 5 pin sealed mini style receptacle. Access to remote voltage sensing is available through the 4 pin sense lead connector (work and electrode), at the feeder via the 14 pin MS-style connector (electrode only), or at the 5 pin MS-style ArcLink® connector (electrode only).

Optional features include DeviceNet or Sync-Tandem capability.

The POWER WAVE® i400 includes an innovative new case design featuring a removable slide mounted power section for ease of service. The case is designed to support the Fanuc R30iA controller and op box (up to 300lbs), matching both the controller's footprint and styling. Mounting is externally accessible for simplified integration. The flexibility of the POWER WAVE® i400 also allows it to be operated as a stand alone unit.

Input power for the Fanuc R30iA controller is supplied through the POWER WAVE® i400 on/off switch. The ArcLink®XT connection is provided through Ethernet. Both power and communication leads are routed to the controller via access holes in the top of the power source. The K2677-1 Integration Kit includes all necessary cables and hardware to complete this task.

General Functional Description

The POWER WAVE® i400 is a high performance, multi-process, digitally controlled inverter power source, designed as a pedestal to support the Fanuc R30iA controller. It may also be used with other controllers as a standalone power source. It is capable of producing a welding output from 5-420 amperes, and is rated for 350A, 100%.

The POWER WAVE® i400 utilizes the latest generation high speed digital controls, and communicates via ArcLink®XT to the Fanuc controller. The inverter power section utilizes state of the art power electronics and is re-connectable for 3 phase input voltages from 200 to 208VAC. A 15A auxiliary receptacle is provided for fume extraction and water cooler accessories.

RECOMMENDED PROCESSES AND EQUIPMENT

RECOMMENDED PROCESSES

The POWER WAVE® i400 is a high speed, multi-process power source capable of regulating the current, voltage, or power of the welding arc. With an output range of 5 to 420 amperes, it supports a number of standard processes including synergic GMAW, GMAW-P and FCAW on various materials especially steel, aluminum and stainless.

PROCESS LIMITATIONS

The software based weld set of the POWER WAVE® i400 limit the process capability within the output range and the safe limits of the machine.

EQUIPMENT LIMITATIONS

The POWER WAVE® i400 is not directly compatible with analog machines or interfaces.

The input power pass-through connection (Terminal Block - 4TB) of the POWER WAVE® i400 is intended to supply power exclusively to the Fanuc R30iA controller. It is designed to support a 3kW maximum robot controller load through cable provided with the K2677-1 Integration Kit.

CASE FRONT

FIGURE B.1

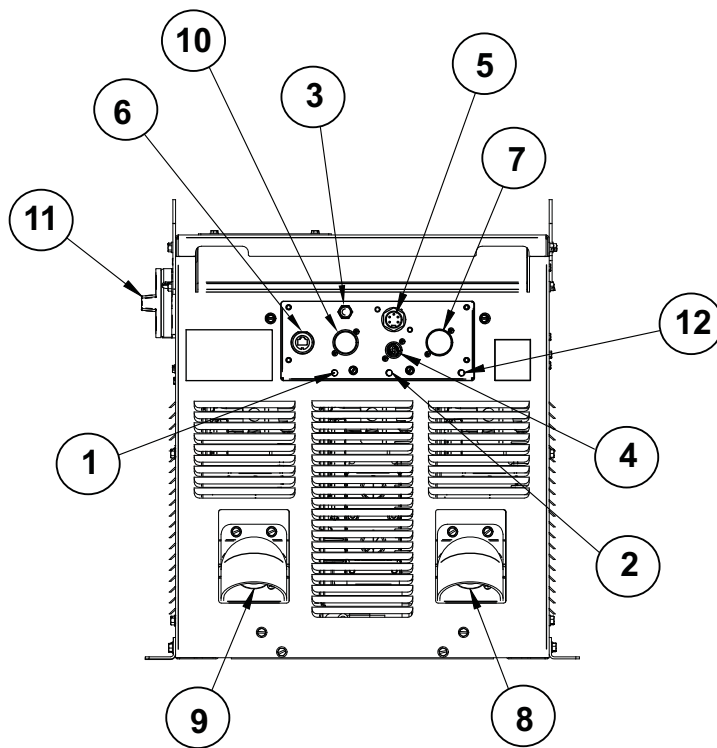

CASE FRONT CONTROL DESCRIPTION

1. Machine Status Indicator: A two color LED that indicates system errors. The POWER WAVE® i400 is equipped with two indicators. One is for the inverter power source, while the other indicates the status of the feeder control system. Normal operation is a steady green light. . Basic error conditions are indicated in the table below. For more information and a detailed listing, see the troubleshooting section of this document or the Service Manual for this machine.

NOTE: The POWER WAVE® i400 status light will flash green, and sometimes red and green, for up to one minute when the machine is first turned on. This is a normal situation as the machine goes through a self test at power up

Light Condition	Meaning
Steady Green	System is okay. Power source communicating normally with the wire feeder and its components.
Blinking Green	Occurs during a reset and indicates the POWER WAVE® i400 is mapping (identifying) each component in the system. Normally this occurs for the first 1-10 seconds after power is turned on or if the system configuration is changed during operation.
Alternating Green and Red	Non-recoverable system fault. Errors are present in the POWER WAVE® i400. Read the error code before the machine is turned off.
	Error code interpretation through the Status light is detailed in the Trouble Shooting section. Individual code digits are flashed in red with a long pause between digits. If more than one code is present, the codes will be separated by a green light.
	To clear the error, turn power source off, and back on to reset. See Troubleshooting section.
Steady Red	Not applicable
Blinking Red	Not applicable

POWER WAVE® i400



2. THERMAL INDICATOR (THERMAL OVERLOAD): A yellow light that comes on when an over temperature situation occurs. Output is disabled and the fan continues to run, until the machine cools down. When cool, the light goes out and output is enabled.

3. CIRCUIT BREAKER (CB1 - 15 AMP): Protects the 40 volt DC supply for the feeder and machine controls.

4. VOLTAGE SENSE CONNECTOR: Allows for separate remote electrode and work sense leads.

Pin	Leads	Function
3	21	Work Voltage Sense
1	67C	Electrode Voltage Sense

5. OPTIONAL DEVICENET OR SYNC-TANDEM CONNECTOR: Available as optional kits to support either DeviceNet communication, or synchronized tandem pulse welding. These options cannot coexist.

DEVICENET CONNECTOR (5 PIN - SEALED MINI STYLE):

Pin	Lead	Function
2	894	+24 VDC DeviceNet
3	893	Common DeviceNet
4	892	DeviceNet H
5	891	DeviceNet L

SYNC-TANDEM CONNECTOR (4 PIN – MS STYLE):

Pin	Lead	Function
A	White	“Ready” H
B	Black/White	“Ready” L
C	Green	“Kill” H
D	Black/Green	“Kill” L

6. ETHERNET CONNECTOR (RJ-45): Used for ArcLink® XT communication. Also used for diagnostics and reprogramming the POWER WAVE® i400.

Pin	Function
1	Transmit +
2	Transmit -
3	Receive +
4	---
5	---
6	Receive -
7	---
8	---

7. WIRE FEEDER RECEPTACLE (14-PIN): For connection to the Auto Drive 4R90 and Power Feed 10R wire feeders.

Pin	Leads	Function
A	539	Motor +
B	541	Motor -
C	521	Solenoid +
D	522	Solenoid Common
E	845	Tach 2A differential signal

F	847	Single Tach input
G	841	+15V Tach supply
H	844	Tach common
I	Open	Reserved for future use
J	GND-A	Shielding drain
K	842	Tach 1A differential signal
L	843	Tach 1B differential signal
M	846	Tach 2B differential signal
N	67A / 67B	Electrode Voltage Sense

8. NEGATIVE OUTPUT TERMINAL

9. POSITIVE OUTPUT TERMINAL

10. ARCLINK® RECEPTACLE:

Pin	Leads	Function
A	153A / 153B	Communication Bus L
B	154A / 154B	Communication Bus H
C	67B / 67C	Electrode Voltage Sense
D	52 / 52A	+40V DC
E	51 / 51A	0 VDC

11. ON / OFF SWITCH: Controls input power to the POWER WAVE® i400, and when properly integrated, the Fanuc R30iA Controller.

⚠ WARNING

The POWER WAVE® i400 ON/OFF switch is NOT intended as a Service Disconnect for this equipment.

12. FEEDER STATUS INDICATOR (See Item 1)

CASE BACK

FIGURE B.2

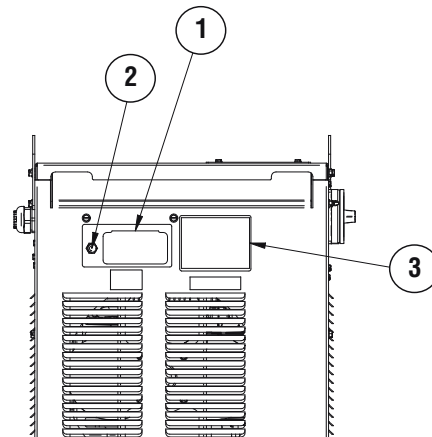

CASE BACK COMPONENTS DESCRIPTION

1. 115V / 15A DUPLEX RECEPTACLE

2. CIRCUIT BREAKER (CB2 - 15 AMP): Provides protection for the 115V auxiliary.

3. RATING PLATE

INTERNAL CONTROLS

FIGURE B.3

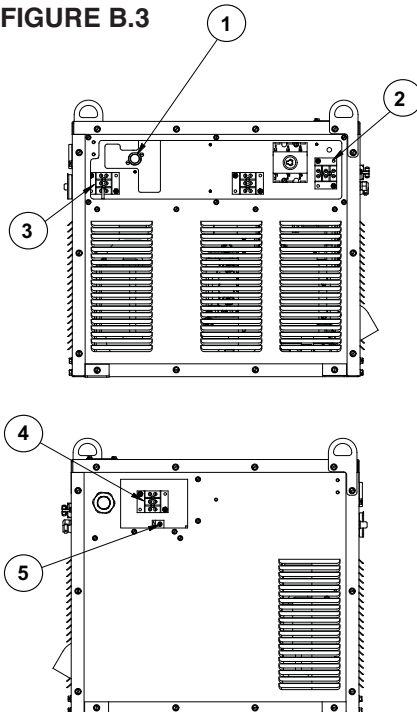

INTERNAL CONTROLS DESCRIPTION

1. **FUSE (F1):** Primary circuit protection for auxiliary power (10A/600V).
2. **ROBOT POWER TERMINAL BLOCK (4TB):** Power supply connection for Fanuc R30iA controller. Supplies primary power through the ON/OFF switch directly to the robot controller.

⚠ CAUTION

This input power pass-through connection is intended to supply power exclusively to the Fanuc R30iA controller. It is designed to support a 3kW maximum robot controller load through cable provided with the K2677-1 Integration Kit.

⚠ WARNING



ELECTRIC SHOCK CAN KILL.

DO NOT ATTEMPT TO BACK FEED INPUT POWER THROUGH THE ROBOT POWER TERMINAL BLOCK (4TB) INTO THE POWER WAVE I400.

THIS IS NOT ITS INTENDED PURPOSE, AND MAY RESULT IN MACHINE DAMAGE, BODILY INJURY OR DEATH.

3. **CHASSIS POWER TERMINAL BLOCK (3TB):** Power connection for internal chassis. Provides power for the inverter and all auxiliary supplies.
4. **INPUT POWER TERMINAL BLOCK (1TB):** Input power connection from main service disconnect.
5. **GROUND TERMINAL:** Earth ground connection.
6. **PC BOARD DIPSWITCHES (NOT SHOWN):** PC Board dipswitches are set at the factory to allow configuration of the POWER WAVE® i400 via the **Fanuc Teach Pendant** or with the Weld Manager Utility (included on the POWER WAVE® Utilities and Service Navigator CD's or available at www.powerwavesoftware.com). The factory default settings are as follows:

Control Board (G4800 Series Hardware):

- S1_{large} = OFF
- S2_{small} = ON

Feed Head Board (L11087 Series Hardware):

- S1_{1 thru 8} = OFF

POWER-UP SEQUENCE

The POWER WAVE® i400 will typically be powered up at the same time as the robotic controller. The status lights will blink green for about a minute while the system is configuring. After this time, the status lights will turn a steady green indicating the machine is ready.

DUTY CYCLE

The POWER WAVE® i400 is rated at 350 amps at 31.5 volts with a 100% duty cycle. It is further rated to provide 400 amps at 34 volts with a 60% duty cycle and 420 amps at 35 volts with a 40% duty cycle. The duty cycle is based on a ten-minute period. A 60% duty cycle represents 6 minutes of welding and 4 minutes of idling in a ten-minute period.

Note:

The POWER WAVE® i400 is capable of producing a peak output current of 700 amps. The allowable maximum average output current is time dependent, but ultimately limited to 450 amps over any 2 second period. If the maximum average is exceeded, the output is disabled to protect the machine. Under these conditions, normal operation can be resumed by cycling the output command.

COMMON WELDING PROCEDURES MAKING A WELD

⚠ WARNING

The serviceability of a product or structure utilizing the welding programs is and must be the sole responsibility of the builder/user. Many variables beyond the control of The Lincoln Electric Company affect the results obtained in applying these programs. These variables include, but are not limited to, welding procedure, plate chemistry and temperature, weldment design, fabrication methods and service requirements. The available range of a welding program may not be suitable for all applications, and the build/user is and must be solely responsible for welding program selection.

Choose the electrode material, electrode size, shielding gas, and process (GMAW, GMAW-P etc.) appropriate for the material to be welded.

Select the weld mode that best matches the desired welding process. The standard weld set shipped with the Power Wave i400 encompasses a wide range of common processes that will meet most needs. If a special weld mode is desired, contact the local Lincoln Electric sales representative.

To make a weld, the Power Wave i400 needs to know the desired welding parameters. The robot controller sends the parameters from the teach pendant (arc voltage, wire feed speed, UltimArc™ value, etc.), to the Power Wave i400 via the ArcLink® communication protocol over the control, Ethernet or optional DeviceNet cables.

BASIC WELDING CONTROLS

Weld Mode

Selecting a weld mode determines the output characteristics of the Power Wave i400 power source. Weld modes are developed with a specific electrode material, electrode size, and shielding gas. For a more complete description of the weld modes programmed into the Power Wave at the factory, refer to the Weld Set Reference Guide supplied with the machine or available at www.powerwavesoftware.com.

Wire Feed Speed (WFS)

In synergic welding modes (GMAW, GMAW-P), WFS is the dominant control parameter. The user adjusts WFS according to factors such as wire size, penetration requirements, heat input, etc. The Power Wave then uses the WFS setting to adjust the voltage and current according to the information contained in the selected weld mode.

Note:

The Power Wave i400 can be configured to use amperage as the dominant control parameter instead of WFS for synergic welding modes. In this configuration the user adjusts amperage according to factors such as wire size, penetration requirements, heat input, etc. The Power Wave then uses the amperage setting to adjust the WFS and voltage according to the information contained in the selected weld mode.

This alternate configuration is regionally enabled based on the robot controller software. Refer to the Fanuc documentation for manual configuration information.

In non-synergic modes, the WFS control behaves like a conventional power source where WFS and voltage are independent adjustments. Therefore, to maintain proper arc characteristics, the operator must adjust the voltage to compensate for any changes made to the WFS.

Volts

In constant voltage modes (GMAW), this control adjusts the welding voltage.

Trim

In pulse synergic welding modes (GMAW-P), the Trim setting adjusts the arc length. Trim is adjustable from 0.50 to 1.50. 1.00 is the nominal setting and is a good starting point for most conditions.

Note:

The Power Wave i400 can also be configured to display Trim as a voltage value. This allows the operator to pre-set an approximate welding voltage rather than a unitless Trim value. The pre-set voltage is limited based on the process, and provides the same range of operation as the corresponding Trim value.

This alternate configuration is regionally enabled based on the robot controller software. Refer to the Fanuc documentation for manual configuration information.

UltimArc™

UltimArc™ allows the operator to vary the arc characteristics from “soft” to “crisp”. UltimArc™ is adjustable from -10.0 to +10.0 with a nominal setting of 0.0.

CONSTANT VOLTAGE WELDING

Synergic CV

In synergic welding modes, WFS is the dominant control parameter. For each wire feed speed, a corresponding voltage is programmed into the machine at the factory. The user adjusts WFS according to factors such as wire size, material thickness, penetration requirements, etc. The Power Wave i400 then uses the WFS setting to select the appropriate nominal voltage. The Power Wave i400 can also be configured to use amperage as the dominant control parameter. In this configuration the Power Wave i400 uses the amperage setting to select the appropriate WFS and nominal voltage. In either case, the user can adjust the voltage higher or lower to compensate for material condition or individual preference.

Non Synergic CV

In non-synergic modes, the machine behaves like a conventional power source. The WFS and voltage are independent adjustments. Therefore, to maintain the arc characteristics, the operator must adjust the voltage to compensate for any changes made to the WFS.

UltimArc™

UltimArc™ adjusts the apparent inductance of the wave shape. The UltimArc™ adjustment is similar to a “pinch” function in that it is inversely proportional to inductance. UltimArc™ is adjustable from -10.0 to +10.0 with a nominal setting of 0. Increasing UltimArc™ results in a crisper, hotter arc. Decreasing the UltimArc™ provides a softer, colder arc.

Pulse Welding

When pulse welding, the power source primarily regulates the arc current, not the arc voltage. During a pulsing cycle, arc current is regulated from a low background level to a high peak level and then back down to the low background level. The average arc voltage increases and decreases as the average arc current is increased or decreased. The peak current, back ground current, rise time, fall time and pulse frequency all affect the average voltage. Since the average voltage for a given wire feed speed can only be determined when all the pulsing waveform parameters are known, a unitless value called “trim” is used for adjusting the arc length.

Trim adjusts the arc length and ranges from 0.50 to 1.50 with a nominal value of 1.00. Increasing the trim value increases the arc length. Decreasing the trim value decreases the arc length. Alternately, trim can be displayed as a quasi-voltage value. This allows the operator to pre-set an approximate welding voltage rather than a unitless trim value. The pre-set voltage is limited based on the process, and provides the same range of operation as the corresponding trim value.

Pulse welding modes are synergic; using wire feed speed as the main control parameter. As the wire feed speed is adjusted, the power source adjusts the waveform parameters to maintain good welding characteristics. The Power Wave i400 can also be configured to use amperage as the dominant control parameter. In this configuration, as the amperage is adjusted, the power source selects the appropriate wire feed speed, and adjusts the waveform parameters to maintain good welding characteristics. In either case, trim is used as a secondary control to change the arc length for material conditions or individual preference.

UltimArc™ adjusts the focus or shape of the arc. UltimArc™ is adjustable from -10.0 to +10.0 with a nominal setting of 0.0. Increasing the UltimArc™ increases the pulse frequency and background current while decreasing the peak current. This results in a tight, stiff arc used for high speed sheet metal welding. Decreasing the UltimArc™ decreases the pulse frequency and background current while increasing the peak current. This results in a soft arc good for out of position welding.

The Power Wave utilizes adaptive control to compensate for changes in the electrical stick-out (distance from the contact tip to the work piece) while welding. The Power Wave waveforms are optimized for a 5/8” to 3/4” stick out depending on the wire type and wire feed speed. The adaptive behavior supports a range of stick outs from approximately 1/2” to 1-1/4”. At low or high wire feed speeds, the adaptive range may be less due to physical limitations of the welding process.

OPTIONAL EQUIPMENT**FACTORY INSTALLED**

None Available.

FIELD INSTALLED

K940-Work Voltage Sense Lead Kit

K2670-[] CE Filter Kit

K2677-1 Integration Kit

COMPATIBLE LINCOLN EQUIPMENT

K2685-2 Auto Drive 4R90 Wire feeder (14-pin control cable).

K1780-2 Power Feed 10 Robotic Wire Drive

For additional Information see Optional Equipment in the Installation Section.

SAFETY PRECAUTIONS

⚠ WARNING



ELECTRIC SHOCK can kill.

- Do not touch electrically live parts or electrode with skin or wet clothing.
- Insulate yourself from work and ground
- Always wear dry insulating gloves.

EXPLODING PARTS can cause injury.



- Failed parts can explode or cause other parts to explode when power is applied.
- Always wear a face shield and long sleeves when servicing.

See additional warning information throughout this Operator's Manual

ROUTINE MAINTENANCE

Routine maintenance consists of periodically blowing out the machine, using a low pressure airstream, to remove accumulated dust and dirt from the intake and outlet louvers, and the cooling channels in the machine.

PERIODIC MAINTENANCE

Calibration of the POWER WAVE® i400 is critical to its operation. Generally speaking the calibration will not need adjustment. However, neglected or improperly calibrated machines may not yield satisfactory weld performance. To ensure optimal performance, the calibration of output Voltage and Current should be checked yearly.

CALIBRATION SPECIFICATION

Output Voltage and Current are calibrated at the factory. Generally speaking the machine calibration will not need adjustment. However, if the weld performance changes, or the yearly calibration check reveals a problem, use the calibration section of the Diagnostics Utility to make the appropriate adjustments.

The calibration procedure itself requires the use of a grid, and certified actual meters for voltage and current. The accuracy of the calibration will be directly affected by the accuracy of the measuring equipment you use. The Diagnostics Utility includes detailed instructions, and is available on the POWER WAVE® Utilities and Service Navigator CD's or available at www.powerwavesoftware.com..

CHASSIS REMOVAL PROCEDURE

⚠ WARNING



ELECTRIC SHOCK can kill.

- Disconnect input power before servicing.
- Do not operate with covers removed.
- Do not touch electrically live parts.
- Only qualified persons should install, use or service this equipment.

(See Figure D.1)

1. Turn off input power to the power source and any other equipment connected to the welding system at the disconnect switch or fuse box before working on the equipment.

2. Remove the weld cables from the output studs, and disconnect all control cables including the Ethernet connection from the control panel.

3. Remove the screws securing the chassis to the cabinet as listed below:

- (6) 10-24 screws securing the reconnect access panel on the front of the machine (ON/OFF switch must be in the OFF position for removal).
- (2) 1/4-20 screws on either side of the control panel located on the right case side.
- (2) 1/4-20 screws just below the output studs located on the right case side.
- (12) 1/4-20 screws from the left case side.

FIGURE D.1

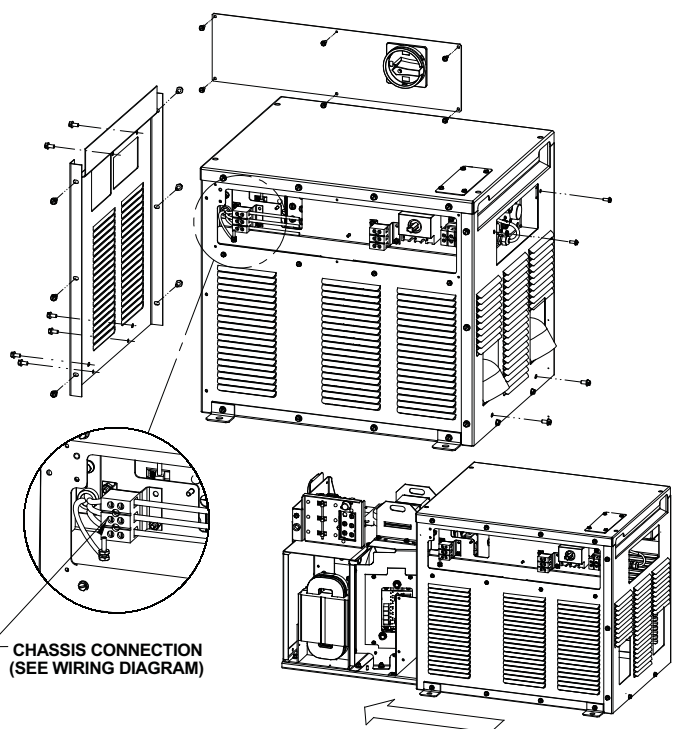

4. Remove the left case side by pulling out from the bottom.
5. Disconnect the chassis input power leads (1E, 2E & 3E) from terminal block "3TB" located in the cabinet reconnect area, and remove the chassis ground from the stud located in front the terminal block.
6. Carefully slide the chassis from the cabinet by pulling on the fan bracket. (see "Location and Mounting" section of this document for instructions on lifting the chassis).

CAPACITOR DISCHARGE PROCEDURE

⚠ CAUTION



- Prior to transporting or servicing chassis it is important to verify the capacitors are completely discharged.

1. Use a DC voltmeter to check that NO voltage is present across the terminals of both capacitors.

Note: Presence of capacitors voltage is also indicated by LED's (See figure D.1a)

2. If voltage is present wait for capacitors to completely discharge (this may take several minutes) or discharge the capacitors as follows:
 - Obtain a power resistor (25 ohms, 25 watts).
 - Hold resistor body with electrically insulated glove. DO NOT TOUCH TERMINALS. CAPACITOR VOLTAGE MAY EXCEED 400VDC. Connect the resistor terminals across the two studs in the position shown. Hold in each position for 10 second. Repeat for both capacitors.
 - Use a DC voltmeter to check that voltage is not present across the terminals of both capacitors.

FIGURE D.1a

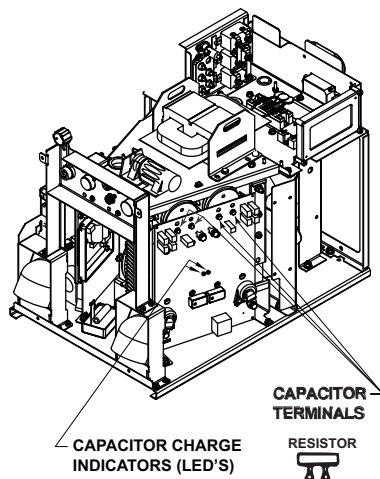

HOW TO USE TROUBLESHOOTING GUIDE**⚠ WARNING**

Service and Repair should only be performed by Lincoln Electric Factory Trained Personnel. Unauthorized repairs performed on this equipment may result in danger to the technician and machine operator and will invalidate your factory warranty. For your safety and to avoid Electrical Shock, please observe all safety notes and precautions detailed throughout this manual.

This Troubleshooting Guide is provided to help you locate and repair possible machine malfunctions. Simply follow the three-step procedure listed below.

Step 1. LOCATE PROBLEM (SYMPTOM).

Look under the column labeled “PROBLEM (SYMPTOMS)”. This column describes possible symptoms that the machine may exhibit. Find the listing that best describes the symptom that the machine is exhibiting.

Step 2. POSSIBLE CAUSE.

The second column labeled “POSSIBLE CAUSE” lists the obvious external possibilities that may contribute to the machine symptom.

Step 3. RECOMMENDED COURSE OF ACTION

This column provides a course of action for the Possible Cause, generally it states to contact your local Lincoln Authorized Field Service Facility.

If you do not understand or are unable to perform the Recommended Course of Action safely, contact your local Lincoln Authorized Field Service Facility.

⚠ CAUTION

If for any reason you do not understand the test procedures or are unable to perform the tests/repairs safely, contact your **Local Lincoln Authorized Field Service Facility** for technical troubleshooting assistance before you proceed.

USING THE STATUS LED TO TROUBLESHOOT SYSTEM PROBLEMS

The POWER WAVE® i400 is equipped with two externally mounted status lights, one for the power source, and one for the wire drive module contained in the power source. If a problem occurs it is important to note the condition of the status lights. **Therefore, prior to cycling power to the system, check the power source status light for error sequences as noted below.**

Included in this section is information about the power source and Wire Drive Module Status LED's, and some basic troubleshooting charts for both machine and weld performance.

The STATUS LIGHTS are dual-color LED's that indicate system errors. Normal operation for each is steady green. Error conditions are indicated in the following Table E.1.

TABLE E.1

Light Condition	Meaning
Steady Green	System OK. Power source is operational, and is communicating normally with all healthy peripheral equipment connected to its ArcLink network.
Blinking Green	Occurs during power up or a system reset, and indicates the POWER WAVE® i400 is mapping (identifying) each component in the system. Normal for first 1-10 seconds after power is turned on, or if the system configuration is changed during operation.
Fast Blinking Green	Under normal conditions indicates Auto-mapping has failed. Also used by the Diagnostics Utility (included on the POWER WAVE® Utilities and Service Navigator CD's or available at www.powerwavesoftware.com) to identify the selected machine when connecting to a specific IP address.
Alternating Green and Red	<p>Non-recoverable system fault. If the Status lights are flashing any combination of red and green, errors are present. Read the error code(s) before the machine is turned off.</p> <p>Error Code interpretation through the Status light is detailed in the Service Manual. Individual code digits are flashed in red with a long pause between digits. If more than one code is present, the codes will be separated by a green light. Only active error conditions will be accessible through the Status Light.</p> <p>Error codes can also be retrieved with the Diagnostics Utility (included on the POWER WAVE® Utilities and Service Navigator CD's or available at www.powerwavesoftware.com). This is the preferred method, since it can access historical information contained in the error log.</p> <p>To clear the active error(s), turn power source off, and back on to reset.</p>
Steady Red	Not applicable.
Blinking Red	Not applicable.

Observe all Safety Guidelines detailed throughout this manual

ERROR CODES FOR THE POWER WAVE®

The following is a partial list of possible error codes for the POWER WAVE® i400. For a complete listing consult the Service Manual for this machine.

POWER SOURCE—WELD CONTROLLER			
Error Code #	LECO (FANUC#)	Indication	
31	Primary (Input) overcurrent error.	49	Excessive Primary current present. May be related to a switch board or output rectifier failure.
32	Capacitor "A" under voltage (right side facing the Switch PC Board)	50	Low voltage on the main capacitors. May be caused by improper input configuration, or an open/short circuit in the primary side of the machine.
33	Capacitor bank "B" under voltage (left side facing the Switch PC Board)	51	
34	Capacitor "A" over voltage (right side facing the Switch PC Board)	52	Excess voltage on the main capacitors. May be caused by improper input configuration, excessive line voltage, or improper capacitor balance (see Error 43)
35	Capacitor "B" over voltage (left side facing the Switch PC Board)	53	
36	Thermal error	54	Indicates over temperature. Usually accompanied by Thermal LED. Check fan operation. Be sure process does not exceed duty cycle limit of the machine.
37	Softstart (pre-charge) error	55	Capacitor precharge failed. Usually accompanied by codes 32 and 33.
39	Misc. hardware fault	57	Unknown glitch has occurred on the fault interrupt circuitry. Sometimes caused by primary over current fault, or intermittent connections in the thermostat circuit.
43	Capacitor delta error	67	The maximum voltage difference between the main capacitors has been exceeded. May be accompanied by errors 32-35. May be caused by an open or short in the primary or secondary circuit(s).
54	Secondary (output) over current	84	The long term average secondary (weld) current limit has been exceeded. This error will immediately turn off the machine output. NOTE: The long term average secondary current limit is 450 amps.
Other	see complete listing		A complete list of error codes is available in the Diagnostics Utility (included on the POWER WAVE® Utilities and Service Navigator CD's or available at www.powerwavesoftware.com). Error codes that contain three or four digits are defined as fatal errors. These codes generally indicate internal errors on the Power Source Control Board. If cycling the input power on the machine does not clear the error, contact the Service Department

CAUTION

If for any reason you do not understand the test procedures or are unable to perform the tests/repairs safely, contact your **Local Lincoln Authorized Field Service Facility** for technical troubleshooting assistance before you proceed.

POWER WAVE® i400



Observe all Safety Guidelines detailed throughout this manual

ERROR CODES FOR THE POWER WAVE®

The following is a partial list of possible error codes for the POWER WAVE® i400. For a complete listing consult the Service Manual for this machine.

WIRE DRIVE MODULE		
Error Code #	LECO (FANUC#)	Indication
81 Motor Overload	129	Long term average motor current limit has been exceeded. Typically indicates mechanical overload of system. If problem continues consider higher torque gear ratio (lower speed range).
82 Motor Overcurrent	130	Absolute maximum motor current level has been exceeded. This is a short term average to protect drive circuitry.
83 Shutdown #1	131	The Shutdown inputs on the POWER WAVE® i400 have been disabled. The presence of these errors indicates the Feed Head Control PCB may contain the wrong operating software.
84 Shutdown #2	132	

CAUTION

If for any reason you do not understand the test procedures or are unable to perform the tests/repairs safely, contact your **Local Lincoln Authorized Field Service Facility** for technical troubleshooting assistance before you proceed.

POWER WAVE® i400



Observe all Safety Guidelines detailed throughout this manual

TROUBLESHOOTING GUIDE

Observe Safety Guidelines detailed in the beginning of this manual.

PROBLEMS (SYMPTOMS)	POSSIBLE CAUSE	RECOMMENDED COURSE OF ACTION
BASIC MACHINE PROBLEMS		
Major physical or electrical damage is evident when the sheet metal covers are removed.	None	1. Contact your local authorized Lincoln Electric Field Service facility for technical assistance.
Input fuses keep blowing	1. Improperly sized input fuses.	1. Make sure fuses are properly sized. See installation section of this manual for recommended sizes.
	2. Improper Weld Procedure requiring output levels in excess of machine rating.	2. Reduce output current, duty cycle, or both.
	3. Major physical or electrical damage is evident when the sheet metal covers are removed.	3. Contact your local authorized Lincoln Electric Field Service facility for technical assistance.
Machine will not power up (no lights)	1. No Input Power.	1. Make sure input supply disconnect has been turned ON. Check input fuses. Make certain that the Power Switch (SW1) on the power source is in the "ON" position.
	2. Fuse F1 (in reconnect area) may have blown.	2. Power Down and replace the fuse.
	3. Circuit breaker CB1 (on the control panel) may have tripped.	3. Power Down and reset CB1.
	4. Improper input voltage selection (multiple input voltage machines only).	4. Power down, check input voltage reconnect according to diagram on reconnect cover.



CAUTION

If for any reason you do not understand the test procedures or are unable to perform the tests/repairs safely, contact your local authorized Lincoln Electric Field Service Facility for technical assistance.

POWER WAVE® i400



Observe all Safety Guidelines detailed throughout this manual

TROUBLESHOOTING GUIDE

Observe Safety Guidelines detailed in the beginning of this manual.

PROBLEMS (SYMPTOMS)	POSSIBLE CAUSE	RECOMMENDED COURSE OF ACTION
BASIC MACHINE PROBLEMS		
<p>Machine won't weld, can't get any output. (CR1 will not pull in.)</p> <p>This problem will normally be accompanied by an error code. Error codes are displayed as a series of red and green flashes by the status light(s). See "Status Light" section of this document for additional information.</p>	1. Input voltage is too low or too high.	1. Make certain that input voltage is correct, according to the Rating Plate located on the rear of the machine.
	2. Thermal Error.	2. See "Thermal LED is ON" section.
	3. Primary current limit has been exceeded. (the main contactor drops out when output is initiated – see error 31).	3. Possible short in output circuit. Turn machine off. Remove all loads from the output of the machine. Turn back on, and activate output. If condition persists, turn power off, and contact an authorized Lincoln Electric Field Service facility.
	4. Inverter Fault - switch pc board, contactor problem, etc.	4. Contact your local authorized Lincoln Electric Field Service facility for technical assistance.
Thermal LED is ON.	1. Improper fan operation.	1. Check for proper fan operation. (Fans should run whenever output power is on.) Check for material blocking intake or exhaust louvers, or for excessive dirt clogging cooling channels in machine.
	2. Output Rectifier board or Choke thermostat.	2. After machine has cooled, reduce load, duty cycle, or both. Check for material blocking intake or exhaust louvers and heat sink fins.
	3. DC Bus PC board thermostat.	3. Check for excessive load on 40VDC supply.
	4. Open thermostat circuit.	4. Check for broken wires, open connections or faulty thermostats on the DC Bus and Output Rectifier heat sinks, and Choke assembly.



CAUTION

If for any reason you do not understand the test procedures or are unable to perform the tests/repairs safely, contact your local authorized Lincoln Electric Field Service Facility for technical assistance.

Observe all Safety Guidelines detailed throughout this manual

TROUBLESHOOTING GUIDE

Observe Safety Guidelines detailed in the beginning of this manual.

PROBLEMS (SYMPTOMS)	POSSIBLE CAUSE	RECOMMENDED COURSE OF ACTION
BASIC MACHINE PROBLEMS		
Auxiliary receptacle is dead.	1. Circuit breaker CB2 (near the 115V receptacle) may have tripped.	1. Power down and reset CB2.
	2. Fuse F1 (in reconnect area) may have blown.	2. Power down and replace the fuse.
"Real Time Clock" no longer functioning	1. Control PC Board Battery.	1. Replace the battery (Type: BS2032)

PROBLEMS (SYMPTOMS)	POSSIBLE CAUSE	RECOMMENDED COURSE OF ACTION
WELD AND ARC QUALITY PROBLEMS		
General degradation of weld performance.	1. Wire feed problem.	1. Check for feeding problems. Check actual WFS vs. preset. Verify proper wire drive and gear ratio has been selected.
	2. Cabling problems.	2. Check for bad connections, excessive loops in cable, etc. NOTE: The presence of heat in the external welding circuit indicates poor connections or undersized cables.
	3. Loss of, or improper Shielding Gas.	3. Verify gas flow and type are correct.
	4. Verify weld mode is correct for process.	4. Select the correct weld mode for the application.
	5. Machine calibration.	5. Verify the calibration of the output current and voltage.
	6. Secondary current limit has been reached.	6. Long term average current is limited to 450A. Adjust procedure to reduce output demand.
Wire burns back to tip when the arc is initiated.	1. Voltage sense lead problem.	1. Check sense lead connections. Check the sense lead configuration and arc polarity. Make sure Electrode and Work connections are not reversed.
	2. Wire feed problem.	2. Check for feeding problems. Verify proper wire drive and gear ratio has been selected.



CAUTION

If for any reason you do not understand the test procedures or are unable to perform the tests/repairs safely, contact your local authorized Lincoln Electric Field Service Facility for technical assistance.

Observe all Safety Guidelines detailed throughout this manual

PROBLEMS (SYMPTOMS)	POSSIBLE CAUSE	RECOMMENDED COURSE OF ACTION
WELD AND ARC QUALITY PROBLEMS		
Wire burns back to tip at the end of the weld.	1. Burnback Time.	1. Reduce burnback time and/or workpoint.
Machine output shuts down during a weld.	1. Inverter or System Fault	1. A non-recoverable inverter fault will interrupt welding, and open the main contactor. This condition will also result in an alternating red and green status light on the control panel. See the Status Light section for more information.
Machine won't produce full output.	1. Input voltage may be too low, limiting output capability of the power source.	1. Make certain that the input voltage is proper, according to the Rating Plate located on the rear of the machine.
	2. Machine calibration.	2. Calibrate secondary current and voltage.
Excessively long and erratic arc.	1. Wire feed problem.	1. Check for feeding problems. Verify proper wire drive and gear ratio has been selected.
	2. Voltage sensing problem.	2. Check sense lead connections. Check the sense lead configuration and arc polarity. Make sure Electrode and Work connections are not reversed.
	3. Loss of, or improper Shielding Gas.	3. Verify gas flow and type are correct.
	4. Machine calibration.	4. Calibrate secondary current and voltage.
Arc loss fault on robot.	1. Possibly caused by wire feeding problem.	1. Check for feeding problems. Verify proper wire drive and gear ratio has been selected. For larger diameter wire, consider the highest torque / lowest range gear ratio available to suit the application.

⚠ CAUTION

If for any reason you do not understand the test procedures or are unable to perform the tests/repairs safely, contact your **Local Lincoln Authorized Field Service Facility** for technical troubleshooting assistance before you proceed.

POWER WAVE® i400



Observe all Safety Guidelines detailed throughout this manual

PROBLEMS (SYMPTOMS)	POSSIBLE CAUSE	RECOMMENDED COURSE OF ACTION
WELD AND ARC QUALITY PROBLEMS		
Arc loss fault on robot.	2. Conduit leading to the wire feeder has bends or twists, which can reduce the wire feed speed.	2. Remove bends and twists in conduit leading to the feeder.
	3. Conduit leading up to the wire feeder from the wire reel is too long.	3. Use a shorter piece of conduit.

PROBLEMS (SYMPTOMS)	POSSIBLE CAUSE	RECOMMENDED COURSE OF ACTION
DeviceNet – PLC Controlled System		
Device does not go on Line.	1. 24v bus power.	1. Verify that LED 10 is on when the DeviceNet network is powered. This can be done with the POWER WAVE® turned on or off.
	2. Baud rate.	2. Verify the baud rate setting is the same as the DeviceNet Master. The baud rate is set via the DeviceNet tab of the Diagnostics Utility.
	3. MAC ID	3. Verify the DeviceNet MAC ID is correct. The Mac ID is set via the DeviceNet tab of the Diagnostics Utility.
	4. Termination	4. Verify that the DeviceNet bus is terminated correctly.
	5. Wiring.	5. Verify the wiring of all multi-port taps and field attachable ends.
	6. EDS Files (Electronic Data Sheet Files)	6. Verify that the correct EDS files are being used if they are needed. The DeviceNet tab of the Diagnostics Utility displays the current Product Code and Vendor Revision of the POWER WAVE®.

⚠ CAUTION

If for any reason you do not understand the test procedures or are unable to perform the tests/repairs safely, contact your **Local Lincoln Authorized Field Service Facility** for technical troubleshooting assistance before you proceed.

POWER WAVE® i400



Observe all Safety Guidelines detailed throughout this manual

PROBLEMS (SYMPTOMS)	POSSIBLE CAUSE	RECOMMENDED COURSE OF ACTION
Device goes off line during welding.	1. Interference / Noise.	1. Verify that DeviceNet cables are not running next to (in close proximity with) current carrying conductors. This includes the welding cables, input cables, etc.
	2. Termination.	2. Verify that the DeviceNet bus is terminated correctly.
	3. Shielding.	3. Verify that the cable shielding is correctly grounded at the bus power supply. The shield should be tied into the bus ground at only one point.
	4. Power Supply.	4. Verify that the DeviceNet bus power supply can supply sufficient current for the devices on the network.
	5. Expected Packet Rate.	5. Verify that $1000/(\text{Expected Packet Rate}) \leq (\text{scans per second})$. The DeviceNet tab of the Diagnostics Utility displays these values.
Output will not come on.	1. DeviceNet trigger not asserted.	1. From the DeviceNet tab of the Diagnostics Utility, select Monitor. The Monitor window will be displayed. Verify under the "Produced Assembly" that "Trigger" is highlighted.
	2. Touch Sense command.	2. From the DeviceNet tab of the Diagnostics Utility, select Monitor. The Monitor window will be displayed. Verify under the "Produced Assembly" that "Touch Sense" is NOT highlighted.
	3. Passive Mode.	3. The DeviceNet tab of the Diagnostics Utility displays the POWER WAVE®'s passive mode status. If the status needs to be changed, select Configure, and make the necessary modification.
	4. Welding Cables.	4. Verify that welding cables are connected properly.
	5. Output Disabled	5. From the DeviceNet tab of the Diagnostics Utility, select Monitor. The Monitor window will be displayed. Verify under the "Produced Assembly" that "Disable Output" is NOT highlighted.

 **CAUTION**

If for any reason you do not understand the test procedures or are unable to perform the tests/repairs safely, contact your **Local Lincoln Authorized Field Service Facility** for technical troubleshooting assistance before you proceed.

POWER WAVE® i400



Observe all Safety Guidelines detailed throughout this manual

PROBLEMS (SYMPTOMS)	POSSIBLE CAUSE	RECOMMENDED COURSE OF ACTION
Output will not come on.	6. Other modules faulted.	6. Verify no other modules are faulted (all system Status Lights should be steady green). Use Diagnostics Utility to display any current faults in the system.
Bad Weld Starting.	1. Wire Feed problem	1. Verify Feeders drive roll tension is not too low allowing the wire to slip in the rolls. Verify wire can be pulled easily through the wire conduit. Verify Contact tip is not blocked.
	2. Strike Wire Feed Speed	2. Verify the Strike Wire Feed Speed set correctly.
	3. Incorrect Weld Schedule	3. Verify the correct weld schedule is selected.
	4. Voltage Sense Leads	4. Verify voltage sense leads are properly connected and configured as described in the instruction manual.
	5. Analog Scans Between Updates	5. The DeviceNet tab of the Diagnostics Utility displays the POWER WAVE®'s "Analog Scans Between Updates" and "I/O Scans/Sec." Verify that "Analog Scans Between Updates" is ¼ of "I/O Scans/Sec" value.
	6. Analog Hysteresis	6. From the DeviceNet tab of the Diagnostics Utility, select Configure. Verify in "Analog Input Channels" that the Hysteresis settings are all 0.
	7. Limit Error	7. Verify all analog input values are within limits.
	8. Fan Out	8. From the DeviceNet tab of the Diagnostics Utility, select Monitor. Verify under "Analog Input Fan Out" that Burnback is present for all analogs in.
	9. Gas	9. Verify Gas is being turned on before the output.

 **CAUTION**

If for any reason you do not understand the test procedures or are unable to perform the tests/repairs safely, contact your **Local Lincoln Authorized Field Service Facility** for technical troubleshooting assistance before you proceed.

POWER WAVE® i400



Observe all Safety Guidelines detailed throughout this manual

PROBLEMS (SYMPTOMS)	POSSIBLE CAUSE	RECOMMENDED COURSE OF ACTION
Analog Inputs don't respond or don't respond quickly.	1. Analog Scans Between Updates.	1. The DeviceNet tab of the Diagnostics Utility displays the POWER WAVE®'s "Analog Scans Between Updates" and "I/O Scans/Sec." Verify that "Analog Scans Between Updates" is ¼ of "I/O Scans/Sec" value.
	2. Analog In Active Selections.	2. From the DeviceNet tab of the Diagnostics Utility, select Configure. Verify in "Analog Input Channels" that the required channels are set active.
	3. Analog Hysteresis.	3. From the DeviceNet tab of the Diagnostics Utility, select Configure. Verify in "Analog Input Channels" that the Hysteresis settings are all 0.
	4. Passive Mode.	4. The DeviceNet tab of the Diagnostics Utility displays the POWER WAVE®'s passive mode status. If the status needs to be changed, select Configure, and make the necessary modification.
Gas purge not working.	1. Out of gas.	1. Verify there is gas available at the input of the gas solenoid.
	2. Gas Purge not asserted.	2. From the DeviceNet tab of the Diagnostics Utility, select Monitor. The Monitor window will be displayed. Verify under the "Produced Assembly" that "Gas Purge" is highlighted.
	3. Passive Mode.	3. The DeviceNet tab of the Diagnostics Utility displays the POWER WAVE®'s passive mode status. If the status needs to be changed, select Configure, and make the necessary modification.
	4. Gas Lines.	4. Verify nothing is obstructing the flow of gas.

 **CAUTION**

If for any reason you do not understand the test procedures or are unable to perform the tests/repairs safely, contact your **Local Lincoln Authorized Field Service Facility** for technical troubleshooting assistance before you proceed.

POWER WAVE® i400



Observe all Safety Guidelines detailed throughout this manual

PROBLEMS (SYMPTOMS)	POSSIBLE CAUSE	RECOMMENDED COURSE OF ACTION
Bad Weld Ending.	1. Burnback Disabled.	1. From the DeviceNet tab of the Diagnostics Utility, select Monitor. The Monitor window will be displayed. Verify under the "State Enabled" that "Burnback" is present.
	2. Burnback Time.	2. Verify that Burnback Time has a value other than 0.
	3. Analog Scans Between Updates.	3. The DeviceNet tab of the Diagnostics Utility displays the POWER WAVE®'s "Analog Scans Between Updates" and "I/O Scans/Sec." Verify that "Analog Scans Between Updates" is ¼ of "I/O Scans/Sec" value.
	4. Limit Error reported at the end of a weld.	4. Verify all welding settings for Burnback and Crater states.
	5. Fan Out.	5. From the DeviceNet tab of the Diagnostics Utility, select Monitor. Verify under "Analog Input Fan Out" that Burnback is present for all analogs in.
	6. Welding set points.	6. Verify Burnback set points for work point, trim, and wave values.
	7. Analog Hysteresis.	7. From the DeviceNet tab of the Diagnostics Utility, select Configure. Verify in "Analog Input Channels" that the Hysteresis settings are all 0.
	8. Gas.	8. Verify Gas is turned on.
Bad Welding.	1. Analog Scans Between Updates.	1. The DeviceNet tab of the Diagnostics Utility displays the POWER WAVE®'s "Analog Scans Between Updates" and "I/O Scans/Sec." Verify that "Analog Scans Between Updates" is ¼ of "I/O Scans/Sec" value.
	2. Voltage Sense Leads.	2. Verify voltage sense leads are properly connected and configured as described in the instruction manual.
	3. Analog Hysteresis	3. From the DeviceNet tab of the Diagnostics Utility, select Configure. Verify in "Analog Input Channels" that the Hysteresis settings are all 0.

 **CAUTION**

If for any reason you do not understand the test procedures or are unable to perform the tests/repairs safely, contact your **Local Lincoln Authorized Field Service Facility** for technical troubleshooting assistance before you proceed.

POWER WAVE® i400



Observe all Safety Guidelines detailed throughout this manual

PROBLEMS (SYMPTOMS)	POSSIBLE CAUSE	RECOMMENDED COURSE OF ACTION
DeviceNet – PLC Controlled System		
Bad Welding.	4. Limit Errors	4. Verify all welding setpoint values are within limits.
	5. Gas	5. Verify Gas remains on until after the weld is complete.
	6. Welding set points	6. Verify welding set points for work point, trim, and wave values.
	7. Wire Drive / Gear selection	7. Verify proper wire drive and gear ratio has been selected
PROBLEMS (SYMPTOMS)	POSSIBLE CAUSE	RECOMMENDED COURSE OF ACTION
ETHERNET		
Cannot Connect.	1. Physical connection.	1. Verify that the correct patch cable or cross over cable is being used (refer to local IT department for assistance). NOTE: • For direct connection to the Fanuc R30iA Controller, use only the cable provided with the K2677-1 Integration kit • Verify the cables are fully inserted into the bulk head connector. • LED 8 located under the PC board ethernet connector will be lit when the machine is connected to another network device.
	2. IP address information.	2. Use Weld Manager (included on the POWER WAVE® Utilities and Service Navigator CD's or available at www.powerwavesoftware.com) to verify the correct IP address information has been entered. NOTE: • The IP address configuration MUST be set to dynamic when connected to the Fanuc R30iA Controller. • Verify no duplicate the IP addresses exist on the network.
	3. Ethernet Speed.	3. Verify that the network device connected to the POWER WAVE® is either a 10-baseT device or a 10/100-baseT device.
Connection Drops while welding.	1. Cable Location.	1. Verify Network cable is not located next to current carrying conductors. This would include input power cables and welding output cables.

⚠ CAUTION

If for any reason you do not understand the test procedures or are unable to perform the tests/repairs safely, contact your **Local Lincoln Authorized Field Service Facility** for technical troubleshooting assistance before you proceed.

POWER WAVE® i400



WIRING DIAGRAM - POWER WAVE i400 (200 - 208V JAPANESE MODEL)

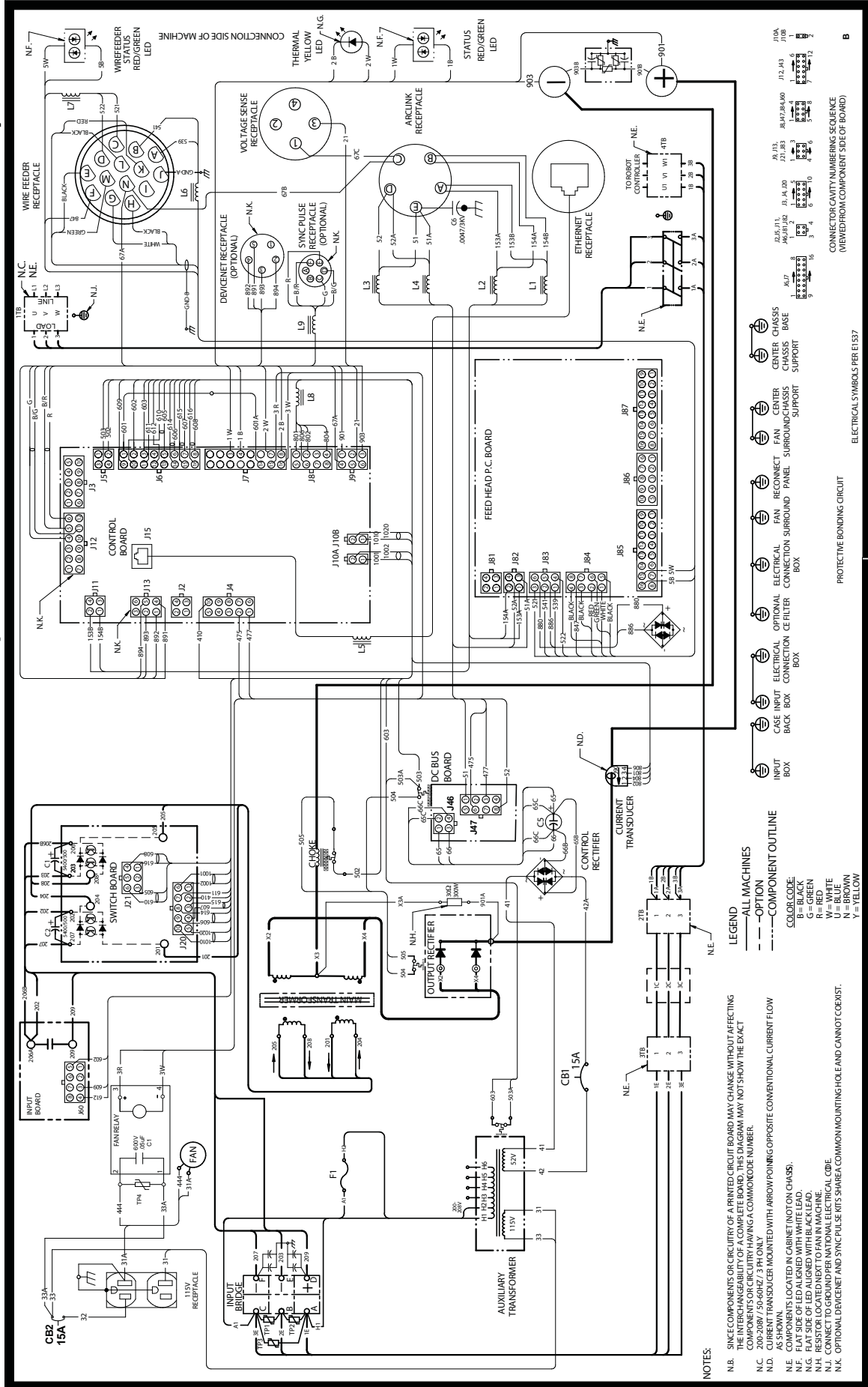

NOTES:

- N.B. SINCE COMPONENTS OR CIRCUITRY OF A PRINTED CIRCUIT BOARD MAY CHANGE WITHOUT AFFECTING THE INTERCHANGEABILITY OF A COMPLETE BOARD, THIS DIAGRAM MAY NOT SHOW THE EXACT COMPONENTS OR CIRCUITRY HAVING A COMMON CODE NUMBER.
- N.C. 200-208V / 50-60HZ / 3 PH ONLY.
- N.D. AS SHOWN.
- N.E. COMPONENTS LOCATED IN CABINET (NOT ON CHASSIS).
- N.F. FLAT SIDE OF LED ALIGNED WITH WHITE LEAD.
- N.G. FLAT SIDE OF LED ALIGNED WITH BLACK LEAD.
- N.I. CONNECT TO GROUND PER NATIONAL ELECTRICAL CODE.
- N.K. OPTIONAL DEVICE NET AND SYNC PULSE KITS SHARE A COMMON MOUNTING HOLE AND CANNOT COEXIST.

LEGEND

- ALL MACHINES
- - - OPTION
- · - · - COMPONENT OUTLINE
- INPUT BOX
- CASE BACK BOX
- ELECTRICAL CONNECTION BOX
- OPTIONAL ELECTRICAL CONNECTION BOX
- FAN RECONNECT SURROUND PANEL
- CENTER CHASSIS SURROUND
- CENTER CHASSIS SUPPORT
- ELECTRICAL SYMBOLS PER E1537

CONNECTOR CAVITY NUMBERING SEQUENCE (VIEW FROM COMPONENT SIDE OF BOARD)

J10A J10B

J10A

J10B

J10C

J10D

J10E

J10F

J10G

J10H

J10I

J10J

J10K

J10L

J10M

J10N

J10O

J10P

J10Q

J10R

J10S

J10T

J10U

J10V

J10W

J10X

J10Y

J10Z

NOTE: This diagram is for reference only. It may not be accurate for all machines covered by this manual. The specific diagram for a particular code is pasted inside the machine on one of the enclosure panels. If the diagram is illegible, write to the Service Department for a replacement. Give the equipment code number.

G6347

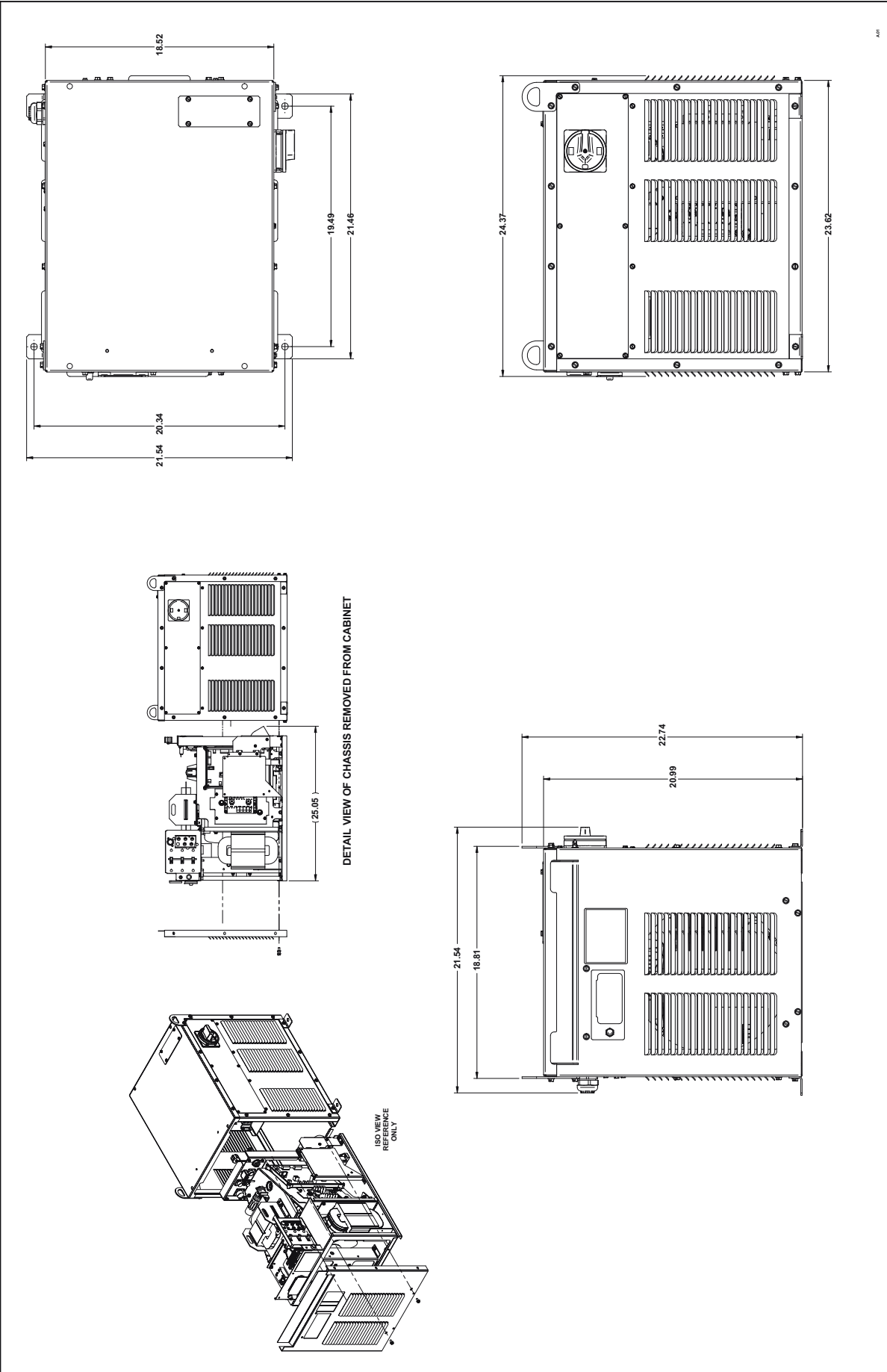

G6044

			
<ul style="list-style-type: none"> ● Keep your head out of fumes. ● Use ventilation or exhaust to remove fumes from breathing zone. 	<ul style="list-style-type: none"> ● Turn power off before servicing. 	<ul style="list-style-type: none"> ● Do not operate with panel open or guards off. 	WARNING
<ul style="list-style-type: none"> ● Los humos fuera de la zona de respiración. ● Mantenga la cabeza fuera de los humos. Utilice ventilación o aspiración para gases. 	<ul style="list-style-type: none"> ● Desconectar el cable de alimentación de poder de la máquina antes de iniciar cualquier servicio. 	<ul style="list-style-type: none"> ● No operar con panel abierto o guardas quitadas. 	Spanish AVISO DE PRECAUCION
<ul style="list-style-type: none"> ● Gardez la tête à l'écart des fumées. ● Utilisez un ventilateur ou un aspirateur pour ôter les fumées des zones de travail. 	<ul style="list-style-type: none"> ● Débranchez le courant avant l'entretien. 	<ul style="list-style-type: none"> ● N'opérez pas avec les panneaux ouverts ou avec les dispositifs de protection enlevés. 	French ATTENTION
<ul style="list-style-type: none"> ● Vermeiden Sie das Einatmen von Schweißrauch! ● Sorgen Sie für gute Be- und Entlüftung des Arbeitsplatzes! 	<ul style="list-style-type: none"> ● Strom vor Wartungsarbeiten abschalten! (Netzstrom völlig öffnen; Maschine anhalten!) 	<ul style="list-style-type: none"> ● Anlage nie ohne Schutzgehäuse oder Innenschutzverkleidung in Betrieb setzen! 	German WARNUNG
<ul style="list-style-type: none"> ● Mantenha seu rosto da fumaça. ● Use ventilação e exaustão para remover fumo da zona respiratória. 	<ul style="list-style-type: none"> ● Não opere com as tampas removidas. ● Desligue a corrente antes de fazer serviço. ● Não toque as partes elétricas nuas. 	<ul style="list-style-type: none"> ● Mantenha-se afastado das partes moventes. ● Não opere com os painéis abertos ou guardas removidas. 	Portuguese ATENÇÃO
<ul style="list-style-type: none"> ● ヒュームから頭を離すようにして下さい。 ● 換気や排煙に十分留意して下さい。 	<ul style="list-style-type: none"> ● メンテナンス・サービスに取りかかる際には、まず電源スイッチを必ず切して下さい。 	<ul style="list-style-type: none"> ● パネルやカバーを取り外したまま機械操作をしないで下さい。 	Japanese 注意事項
<ul style="list-style-type: none"> ● 頭部遠離煙霧。 ● 在呼吸區使用通風或排風器除煙。 	<ul style="list-style-type: none"> ● 維修前切斷電源。 	<ul style="list-style-type: none"> ● 儀表板打開或沒有安全罩時不準作業。 	Chinese 警告
<ul style="list-style-type: none"> ● 얼굴로부터 용접가스를 멀리하십시오. ● 호흡지역으로부터 용접가스를 제거하기 위해 가스제거기나 뽕풍기를 사용하십시오. 	<ul style="list-style-type: none"> ● 보수전에 전원을 차단하십시오. 	<ul style="list-style-type: none"> ● 관널이 열린 상태로 작동치 마십시오. 	Korean 위험
<ul style="list-style-type: none"> ● ابعد رأسك بعيداً عن الدخان. ● استعمل التهوية أو جهاز ضغط الدخان للخارج لكي تبعد الدخان عن المنطقة التي تتنفس فيها. 	<ul style="list-style-type: none"> ● اقطع التيار الكهربائي قبل القيام بأية صيانة. 	<ul style="list-style-type: none"> ● لا تشغيل هذا الجهاز اذا كانت الاغطية الحديدية الواقية ليست عليه. 	Arabic تحذير

LEIA E COMPREENDA AS INSTRUÇÕES DO FABRICANTE PARA ESTE EQUIPAMENTO E AS PARTES DE USO, E SIGA AS PRÁTICAS DE SEGURANÇA DO EMPREGADOR.

使う機械や溶材のメーカーの指示書をよく読み、まず理解して下さい。そして貴社の安全規定に従って下さい。

請詳細閱讀並理解製造廠提供的說明以及應該使用的銀焊材料，並請遵守貴方的有關勞動保護規定。

이 제품에 동봉된 작업지침서를 숙지하시고 귀사의 작업자 안전수칙을 준수하시기 바랍니다.

اقرأ بتمعن وافهم تعليمات المصنع المنتج لهذه المعدات والمواد قبل استعمالها واتبع تعليمات الوقاية لصاحب العمل.

			
WARNING	<ul style="list-style-type: none"> Do not touch electrically live parts or electrode with skin or wet clothing. Insulate yourself from work and ground. 	<ul style="list-style-type: none"> Keep flammable materials away. 	<ul style="list-style-type: none"> Wear eye, ear and body protection.
Spanish AVISO DE PRECAUCION	<ul style="list-style-type: none"> No toque las partes o los electrodos bajo carga con la piel o ropa mojada. Aislese del trabajo y de la tierra. 	<ul style="list-style-type: none"> Mantenga el material combustible fuera del área de trabajo. 	<ul style="list-style-type: none"> Protéjase los ojos, los oídos y el cuerpo.
French ATTENTION	<ul style="list-style-type: none"> Ne laissez ni la peau ni des vêtements mouillés entrer en contact avec des pièces sous tension. Isolez-vous du travail et de la terre. 	<ul style="list-style-type: none"> Gardez à l'écart de tout matériel inflammable. 	<ul style="list-style-type: none"> Protégez vos yeux, vos oreilles et votre corps.
German WARNUNG	<ul style="list-style-type: none"> Berühren Sie keine stromführenden Teile oder Elektroden mit Ihrem Körper oder feuchter Kleidung! Isolieren Sie sich von den Elektroden und dem Erdboden! 	<ul style="list-style-type: none"> Entfernen Sie brennbares Material! 	<ul style="list-style-type: none"> Tragen Sie Augen-, Ohren- und Körperschutz!
Portuguese ATENÇÃO	<ul style="list-style-type: none"> Não toque partes elétricas e electrodos com a pele ou roupa molhada. Isole-se da peça e terra. 	<ul style="list-style-type: none"> Mantenha inflamáveis bem guardados. 	<ul style="list-style-type: none"> Use proteção para a vista, ouvido e corpo.
Japanese 注意事項	<ul style="list-style-type: none"> 通電中の電気部品、又は溶材にヒブやぬれた布で触れないこと。 施工物やアースから身体が絶縁されている様にして下さい。 	<ul style="list-style-type: none"> 燃えやすいものの側での溶接作業は絶対にしてはなりません。 	<ul style="list-style-type: none"> 目、耳及び身体に保護具をして下さい。
Chinese 警告	<ul style="list-style-type: none"> 皮肤或湿衣物切勿接触带电部件及焊条。 使你自已与地面和工件绝缘。 	<ul style="list-style-type: none"> 把一切易燃物品移离工作场所。 	<ul style="list-style-type: none"> 佩戴眼、耳及身体劳动保护用具。
Korean 위험	<ul style="list-style-type: none"> 전도체나 웅접봉을 젖은 헝겍 또는 피부로 절대 접촉치 마십시오. 모재와 접지를 접촉치 마십시오. 	<ul style="list-style-type: none"> 인화성 물질을 접근 시키지 마십시오. 	<ul style="list-style-type: none"> 눈, 귀와 몸에 보호장구를 착용하십시오.
Arabic تحذير	<ul style="list-style-type: none"> لا تلمس الاجزاء التي يسري فيها التيار الكهربائي أو الألكترود بجلد الجسم أو بالملابس المبللة بالماء. ضع عازل لا على جسمك خلال العمل. 	<ul style="list-style-type: none"> ضع المواد القابلة للاشتعال في مكان بعيد. 	<ul style="list-style-type: none"> ضع أدوات وملابس واقية على عينيك وأذنيك وجسمك.

READ AND UNDERSTAND THE MANUFACTURER'S INSTRUCTION FOR THIS EQUIPMENT AND THE CONSUMABLES TO BE USED AND FOLLOW YOUR EMPLOYER'S SAFETY PRACTICES.

SE RECOMIENDA LEER Y ENTENDER LAS INSTRUCCIONES DEL FABRICANTE PARA EL USO DE ESTE EQUIPO Y LOS CONSUMIBLES QUE VA A UTILIZAR, SIGA LAS MEDIDAS DE SEGURIDAD DE SU SUPERVISOR.

LISEZ ET COMPRENEZ LES INSTRUCTIONS DU FABRICANT EN CE QUI REGARDE CET EQUIPMENT ET LES PRODUITS A ETRE EMPLOYES ET SUIVEZ LES PROCEDURES DE SECURITE DE VOTRE EMPLOYEUR.

LESEN SIE UND BEFOLGEN SIE DIE BETRIEBSANLEITUNG DER ANLAGE UND DEN ELEKTRODENEINSATZ DES HERSTELLERS. DIE UNFALLVERHÜTUNGSVORSCHRIFTEN DES ARBEITGEBERS SIND EBENFALLS ZU BEACHTEN.



• World's Leader in Welding and Cutting Products •

• Sales and Service through Subsidiaries and Distributors Worldwide •

Cleveland, Ohio 44117-1199 U.S.A. TEL: 216.481.8100 FAX: 216.486.1751 WEB SITE: www.lincolnelectric.com