

SMALL WIRE FEEDER WELDERS (125A) WIRING DIAGRAM M22477-1 REV: A

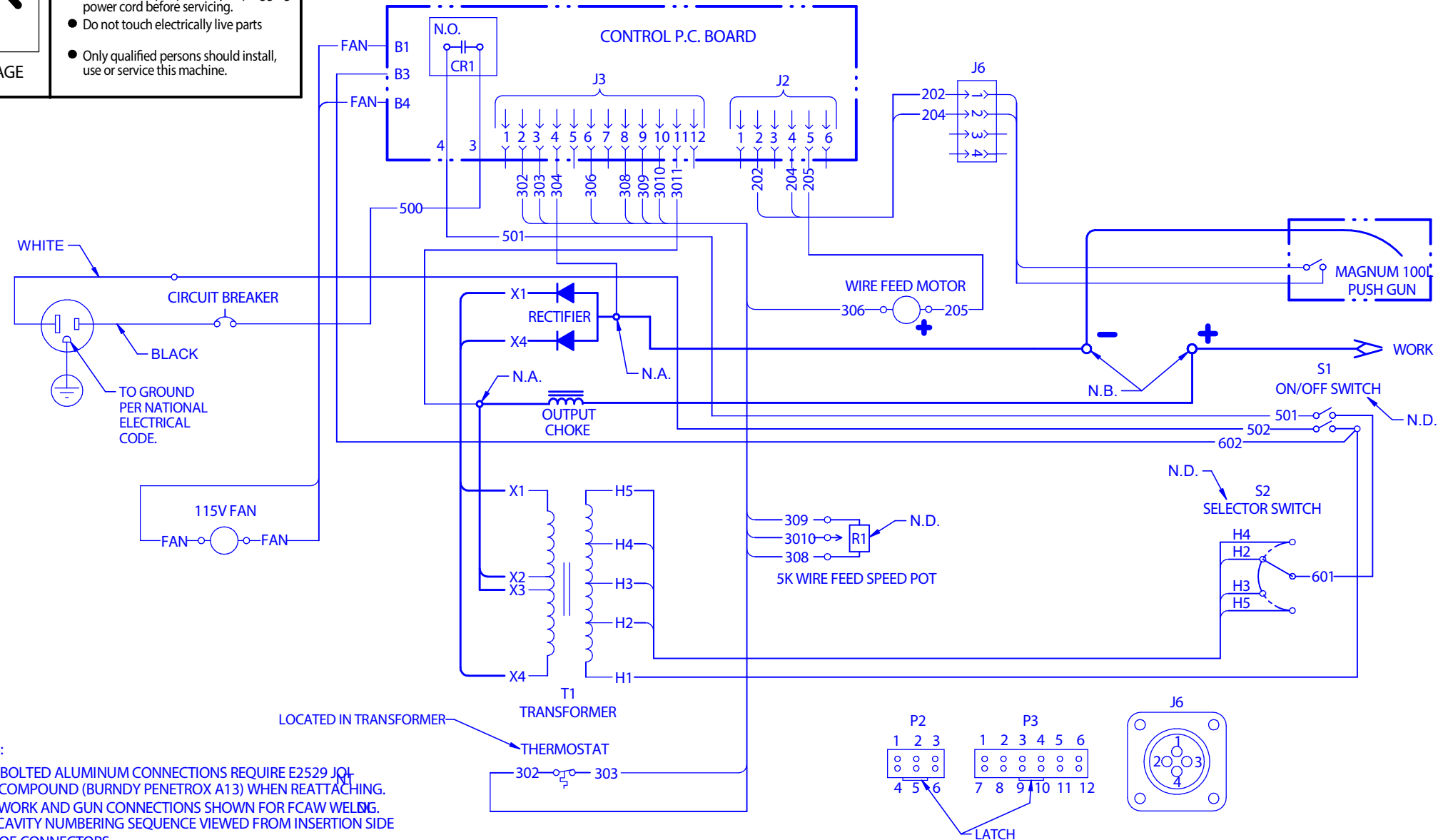

WARNING
HIGH VOLTAGE
can kill

- Do not operate with covers removed.
- Disconnect input power by unplugging power cord before servicing.
- Do not touch electrically live parts
- Only qualified persons should install, use or service this machine.



NOTES:
 N.A. BOLTED ALUMINUM CONNECTIONS REQUIRE E2529 JOL COMPOUND (BURNDY PENETROX A13) WHEN REATTACHING.
 N.B. WORK AND GUN CONNECTIONS SHOWN FOR FCAW WELDING.
 N.C. CAVITY NUMBERING SEQUENCE VIEWED FROM INSERTION SIDE OF CONNECTORS.
 N.D. COMPONENT VIEWED FROM REAR.



CLEVELAND, OHIO U.S.A.