

## Operator's Manual

# COOL ARC<sup>®</sup> 55 S WATER COOLER

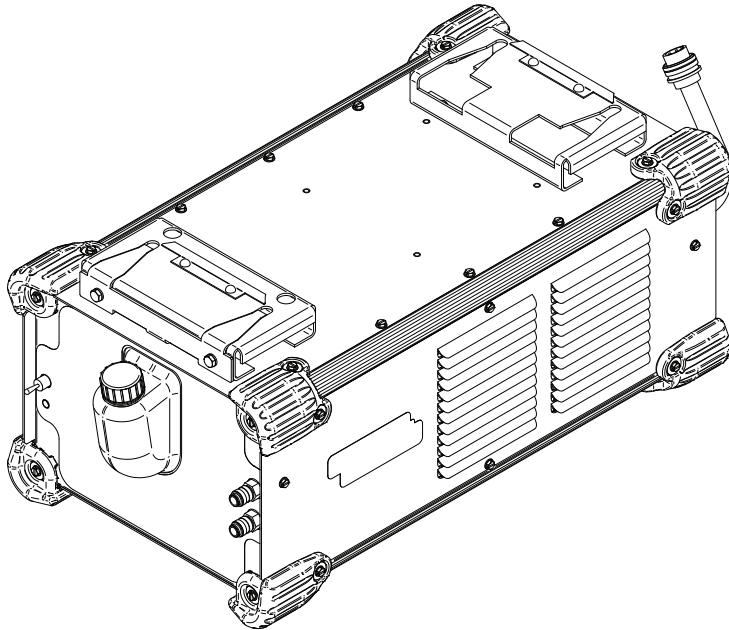

For use with machines having Code Numbers:

**11949, 12889**



**Register your machine:**

[www.lincolnelectric.com/registration](http://www.lincolnelectric.com/registration)

**Authorized Service and Distributor Locator:**

[www.lincolnelectric.com/locator](http://www.lincolnelectric.com/locator)

**Save for future reference**

Date Purchased

Code: (ex: 10859)

Serial: (ex: U1060512345)

# THANK YOU FOR SELECTING A QUALITY PRODUCT BY LINCOLN ELECTRIC.

## PLEASE EXAMINE CARTON AND EQUIPMENT FOR DAMAGE IMMEDIATELY

When this equipment is shipped, title passes to the purchaser upon receipt by the carrier. Consequently, claims for material damaged in shipment must be made by the purchaser against the transportation company at the time the shipment is received.

## SAFETY DEPENDS ON YOU

Lincoln arc welding and cutting equipment is designed and built with safety in mind. However, your overall safety can be increased by proper installation ... and thoughtful operation on your part. **DO NOT INSTALL, OPERATE OR REPAIR THIS EQUIPMENT WITHOUT READING THIS MANUAL AND THE SAFETY PRECAUTIONS CONTAINED THROUGHOUT.** And, most importantly, think before you act and be careful.

### **WARNING**

This statement appears where the information must be followed exactly to avoid serious personal injury or loss of life.

### **CAUTION**

This statement appears where the information must be followed to avoid minor personal injury or damage to this equipment.



## KEEP YOUR HEAD OUT OF THE FUMES.

**DON'T** get too close to the arc. Use corrective lenses if necessary to stay a reasonable distance away from the arc.

**READ** and obey the Safety Data Sheet (SDS) and the warning label that appears on all containers of welding materials.

**USE ENOUGH VENTILATION** or exhaust at the arc, or both, to keep the fumes and gases from your breathing zone and the general area.

**IN A LARGE ROOM OR OUTDOORS**, natural ventilation may be adequate if you keep your head out of the fumes (See below).

**USE NATURAL DRAFTS** or fans to keep the fumes away from your face.

If you develop unusual symptoms, see your supervisor. Perhaps the welding atmosphere and ventilation system should be checked.

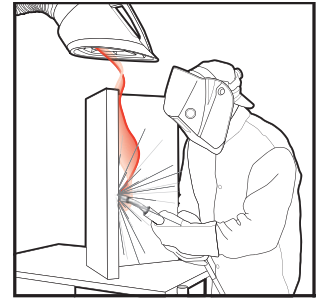

## WEAR CORRECT EYE, EAR & BODY PROTECTION

**PROTECT** your eyes and face with welding helmet properly fitted and with proper grade of filter plate (See ANSI Z49.1).

**PROTECT** your body from welding spatter and arc flash with protective clothing including woolen clothing, flame-proof apron and gloves, leather leggings, and high boots.

**PROTECT** others from splatter, flash, and glare with protective screens or barriers.

**IN SOME AREAS**, protection from noise may be appropriate.

**BE SURE** protective equipment is in good condition.

Also, wear safety glasses in work area **AT ALL TIMES.**



## SPECIAL SITUATIONS

**DO NOT WELD OR CUT** containers or materials which previously had been in contact with hazardous substances unless they are properly cleaned. This is extremely dangerous.

**DO NOT WELD OR CUT** painted or plated parts unless special precautions with ventilation have been taken. They can release highly toxic fumes or gases.

## Additional precautionary measures

**PROTECT** compressed gas cylinders from excessive heat, mechanical shocks, and arcs; fasten cylinders so they cannot fall.

**BE SURE** cylinders are never grounded or part of an electrical circuit.

**REMOVE** all potential fire hazards from welding area.

**ALWAYS HAVE FIRE FIGHTING EQUIPMENT READY FOR IMMEDIATE USE AND KNOW HOW TO USE IT.**



## SECTION A: WARNINGS



### CALIFORNIA PROPOSITION 65 WARNINGS



**WARNING:** Breathing diesel engine exhaust exposes you to chemicals known to the State of California to cause cancer and birth defects, or other reproductive harm.

- Always start and operate the engine in a well-ventilated area.
- If in an exposed area, vent the exhaust to the outside.
- Do not modify or tamper with the exhaust system.
- Do not idle the engine except as necessary.

For more information go to [www.P65warnings.ca.gov/diesel](http://www.P65warnings.ca.gov/diesel)

**WARNING:** This product, when used for welding or cutting, produces fumes or gases which contain chemicals known to the State of California to cause birth defects and, in some cases, cancer. (California Health & Safety Code § 25249.5 *et seq.*)



**WARNING:** Cancer and Reproductive Harm  
[www.P65warnings.ca.gov](http://www.P65warnings.ca.gov)

**ARC WELDING CAN BE HAZARDOUS. PROTECT YOURSELF AND OTHERS FROM POSSIBLE SERIOUS INJURY OR DEATH. KEEP CHILDREN AWAY. PACEMAKER WEARERS SHOULD CONSULT WITH THEIR DOCTOR BEFORE OPERATING.**

Read and understand the following safety highlights. For additional safety information, it is strongly recommended that you purchase a copy of "Safety in Welding & Cutting - ANSI Standard Z49.1" from the American Welding Society, P.O. Box 351040, Miami, Florida 33135 or CSA Standard W117.2. A Free copy of "Arc Welding Safety" booklet E205 is available from the Lincoln Electric Company, 22801 St. Clair Avenue, Cleveland, Ohio 44117-1199.

**BE SURE THAT ALL INSTALLATION, OPERATION, MAINTENANCE AND REPAIR PROCEDURES ARE PERFORMED ONLY BY QUALIFIED INDIVIDUALS.**



### FOR ENGINE POWERED EQUIPMENT.

- Turn the engine off before troubleshooting and maintenance work unless the maintenance work requires it to be running.
- Operate engines in open, well-ventilated areas or vent the engine exhaust fumes outdoors.
- Do not add the fuel near an open flame welding arc or when the engine is running. Stop the engine and allow it to cool before refueling to prevent spilled fuel from vaporizing on contact



with hot engine parts and igniting. Do not spill fuel when filling tank. If fuel is spilled, wipe it up and do not start engine until fumes have been eliminated.

- Keep all equipment safety guards, covers and devices in position and in good repair. Keep hands, hair, clothing and tools away from V-belts, gears, fans and all other moving parts when starting, operating or repairing equipment.
- In some cases it may be necessary to remove safety guards to perform required maintenance. Remove guards only when necessary and replace them when the maintenance requiring their removal is complete. Always use the greatest care when working near moving parts.
- Do not put your hands near the engine fan. Do not attempt to override the governor or idler by pushing on the throttle control rods while the engine is running.
- To prevent accidentally starting gasoline engines while turning the engine or welding generator during maintenance work, disconnect the spark plug wires, distributor cap or magneto wire as appropriate.
- To avoid scalding, do not remove the radiator pressure cap when the engine is hot.
- Using a generator indoors CAN KILL YOU IN MINUTES.
- Generator exhaust contains carbon monoxide. This is a poison you cannot see or smell.
- NEVER use inside a home or garage, EVEN IF doors and windows are open.
- Only use OUTSIDE and far away from windows, doors and vents.
- Avoid other generator hazards. READ MANUAL BEFORE USE.



### ELECTRIC AND MAGNETIC FIELDS MAY BE DANGEROUS



- Electric current flowing through any conductor causes localized Electric and Magnetic Fields (EMF). Welding current creates EMF fields around welding cables and welding machines
- EMF fields may interfere with some pacemakers, and welders having a pacemaker should consult their physician before welding.
- Exposure to EMF fields in welding may have other health effects which are now not known.
- All welders should use the following procedures in order to minimize exposure to EMF fields from the welding circuit:
  - Route the electrode and work cables together - Secure them with tape when possible.
  - Never coil the electrode lead around your body.
  - Do not place your body between the electrode and work cables. If the electrode cable is on your right side, the work cable should also be on your right side.
  - Connect the work cable to the workpiece as close as possible to the area being welded.
  - Do not work next to welding power source.



## ELECTRIC SHOCK CAN KILL.



- 3.a. The electrode and work (or ground) circuits are electrically “hot” when the welder is on. Do not touch these “hot” parts with your bare skin or wet clothing. Wear dry, hole-free gloves to insulate hands.
- 3.b. Insulate yourself from work and ground using dry insulation. Make certain the insulation is large enough to cover your full area of physical contact with work and ground.

**In addition to the normal safety precautions, if welding must be performed under electrically hazardous conditions (in damp locations or while wearing wet clothing; on metal structures such as floors, gratings or scaffolds; when in cramped positions such as sitting, kneeling or lying, if there is a high risk of unavoidable or accidental contact with the workpiece or ground) use the following equipment:**

- Semiautomatic DC Constant Voltage (Wire) Welder.
  - DC Manual (Stick) Welder.
  - AC Welder with Reduced Voltage Control.
- 3.c. In semiautomatic or automatic wire welding, the electrode, electrode reel, welding head, nozzle or semiautomatic welding gun are also electrically “hot”.
  - 3.d. Always be sure the work cable makes a good electrical connection with the metal being welded. The connection should be as close as possible to the area being welded.
  - 3.e. Ground the work or metal to be welded to a good electrical (earth) ground.
  - 3.f. Maintain the electrode holder, work clamp, welding cable and welding machine in good, safe operating condition. Replace damaged insulation.
  - 3.g. Never dip the electrode in water for cooling.
  - 3.h. Never simultaneously touch electrically “hot” parts of electrode holders connected to two welders because voltage between the two can be the total of the open circuit voltage of both welders.
  - 3.i. When working above floor level, use a safety belt to protect yourself from a fall should you get a shock.
  - 3.j. Also see Items 6.c. and 8.



## ARC RAYS CAN BURN.



- 4.a. Use a shield with the proper filter and cover plates to protect your eyes from sparks and the rays of the arc when welding or observing open arc welding. Headshield and filter lens should conform to ANSI Z87.1 standards.
- 4.b. Use suitable clothing made from durable flame-resistant material to protect your skin and that of your helpers from the arc rays.
- 4.c. Protect other nearby personnel with suitable, non-flammable screening and/or warn them not to watch the arc nor expose themselves to the arc rays or to hot spatter or metal.



## FUMES AND GASES CAN BE DANGEROUS.



- 5.a. Welding may produce fumes and gases hazardous to health. Avoid breathing these fumes and gases. When welding, keep your head out of the fume. Use enough ventilation and/or exhaust at the arc to keep fumes and gases away from the breathing zone. **When welding hardfacing (see instructions on container or SDS) or on lead or cadmium plated steel and other metals or coatings which produce highly toxic fumes, keep exposure as low as possible and within applicable OSHA PEL and ACGIH TLV limits using local exhaust or mechanical ventilation unless exposure assessments indicate otherwise. In confined spaces or in some circumstances, outdoors, a respirator may also be required. Additional precautions are also required when welding on galvanized steel.**
- 5.b. The operation of welding fume control equipment is affected by various factors including proper use and positioning of the equipment, maintenance of the equipment and the specific welding procedure and application involved. Worker exposure level should be checked upon installation and periodically thereafter to be certain it is within applicable OSHA PEL and ACGIH TLV limits.
- 5.c. Do not weld in locations near chlorinated hydrocarbon vapors coming from degreasing, cleaning or spraying operations. The heat and rays of the arc can react with solvent vapors to form phosgene, a highly toxic gas, and other irritating products.
- 5.d. Shielding gases used for arc welding can displace air and cause injury or death. Always use enough ventilation, especially in confined areas, to insure breathing air is safe.
- 5.e. Read and understand the manufacturer’s instructions for this equipment and the consumables to be used, including the Safety Data Sheet (SDS) and follow your employer’s safety practices. SDS forms are available from your welding distributor or from the manufacturer.
- 5.f. Also see item 1.b.



## WELDING AND CUTTING SPARKS CAN CAUSE FIRE OR EXPLOSION.



- 6.a. Remove fire hazards from the welding area. If this is not possible, cover them to prevent the welding sparks from starting a fire. Remember that welding sparks and hot materials from welding can easily go through small cracks and openings to adjacent areas. Avoid welding near hydraulic lines. Have a fire extinguisher readily available.
- 6.b. Where compressed gases are to be used at the job site, special precautions should be used to prevent hazardous situations. Refer to "Safety in Welding and Cutting" (ANSI Standard Z49.1) and the operating information for the equipment being used.
- 6.c. When not welding, make certain no part of the electrode circuit is touching the work or ground. Accidental contact can cause overheating and create a fire hazard.
- 6.d. Do not heat, cut or weld tanks, drums or containers until the proper steps have been taken to insure that such procedures will not cause flammable or toxic vapors from substances inside. They can cause an explosion even though they have been "cleaned". For information, purchase "Recommended Safe Practices for the Preparation for Welding and Cutting of Containers and Piping That Have Held Hazardous Substances", AWS F4.1 from the American Welding Society (see address above).
- 6.e. Vent hollow castings or containers before heating, cutting or welding. They may explode.
- 6.f. Sparks and spatter are thrown from the welding arc. Wear oil free protective garments such as leather gloves, heavy shirt, cuffless trousers, high shoes and a cap over your hair. Wear ear plugs when welding out of position or in confined places. Always wear safety glasses with side shields when in a welding area.
- 6.g. Connect the work cable to the work as close to the welding area as practical. Work cables connected to the building framework or other locations away from the welding area increase the possibility of the welding current passing through lifting chains, crane cables or other alternate circuits. This can create fire hazards or overheat lifting chains or cables until they fail.
- 6.h. Also see item 1.c.
- 6.i. Read and follow NFPA 51B "Standard for Fire Prevention During Welding, Cutting and Other Hot Work", available from NFPA, 1 Batterymarch Park, PO box 9101, Quincy, MA 022690-9101.
- 6.j. Do not use a welding power source for pipe thawing.



## CYLINDER MAY EXPLODE IF DAMAGED.

- 7.a. Use only compressed gas cylinders containing the correct shielding gas for the process used and properly operating regulators designed for the gas and pressure used. All hoses, fittings, etc. should be suitable for the application and maintained in good condition. 
- 7.b. Always keep cylinders in an upright position securely chained to an undercarriage or fixed support.
- 7.c. Cylinders should be located:
  - Away from areas where they may be struck or subjected to physical damage.
  - A safe distance from arc welding or cutting operations and any other source of heat, sparks, or flame.
- 7.d. Never allow the electrode, electrode holder or any other electrically "hot" parts to touch a cylinder.
- 7.e. Keep your head and face away from the cylinder valve outlet when opening the cylinder valve.
- 7.f. Valve protection caps should always be in place and hand tight except when the cylinder is in use or connected for use.
- 7.g. Read and follow the instructions on compressed gas cylinders, associated equipment, and CGA publication P-1, "Precautions for Safe Handling of Compressed Gases in Cylinders," available from the Compressed Gas Association, 14501 George Carter Way Chantilly, VA 20151.



## FOR ELECTRICALLY POWERED EQUIPMENT.



- 8.a. Turn off input power using the disconnect switch at the fuse box before working on the equipment.
- 8.b. Install equipment in accordance with the U.S. National Electrical Code, all local codes and the manufacturer's recommendations.
- 8.c. Ground the equipment in accordance with the U.S. National Electrical Code and the manufacturer's recommendations.

**Refer to**  
**<http://www.lincolnelectric.com/safety>**  
**for additional safety information.**

	Page
<b>Installation .....</b>	<b>Section A</b>
Technical Specifications .....	A-1
Safety Precautions.....	A-2
Unpacking the COOL ARC® 55 S.....	A-2
Installation on Power Source .....	A-2
Location and Mounting.....	A-2
Filling the Coolant Reservoir .....	A-3
Coolant “In” and “out” Connections .....	A-4
Input Power Connection.....	A-4
Arlink Connections .....	A-4
Installation of Water Cooled Accessories .....	A-5
Water Cooled TIG Torch and MIG Gun .....	A-5
Connection to Wire Feeders .....	A-5
K529-10 Power Input Cable with Water and Gas Hoses .....	A-5
<b>Operation .....</b>	<b>Section B</b>
Safety Precautions.....	B-1
Product Description, Power-Up Sequence .....	B-1
Recommended Processes and Equipment, Common Equipment Packages .....	B-1
Turning the System “On” .....	B-1
Cooling Efficiency.....	B-2
Equipment Limitations, Case Front Description .....	B-3
Case Back Descriptions .....	B-4
<b>Accessories .....</b>	<b>Section C</b>
Optional Equipment (Field Installed) .....	C-1
<b>Maintenance .....</b>	<b>Section D</b>
Safety Precautions .....	D-1
Routine Maintenance .....	D-1
Periodic Maintenance .....	D-1
Pump Maintenance .....	D-1
Heat Exchanger .....	D-1
Reservoir Coolant Level.....	D-1
Coolant Treatment Recommendation .....	D-2
Pump Inlet Strainer .....	D-2
Inspect Condition of Coolant.....	D-2
Service the Pump Inlet Strainer .....	D-3
Additional Service Notes.....	D-3
<b>Troubleshooting .....</b>	<b>Section E</b>
Safety Precautions.....	E-1
How to Use Troubleshooting Guide .....	E-1
Using the Status LED to Troubleshoot System .....	E-2
Error Codes for COOL ARC® 55 S.....	E-3
Troubleshooting Guide .....	E-4
<b>Wiring Diagrams .....</b>	<b>Section F</b>
Wiring Diagram .....	F-1
Dimension Print.....	F-2
<b>Parts List.....</b>	<b>P-716</b>



## TECHNICAL SPECIFICATIONS – COOL ARC® 55 S

Product No. / Model	K3086-2 ( COOL ARC ® 55 S ) VIA 3-Prong Plug NEMA Type 5-15P	
Input	115VAC 60 Hz 1 Phase 40 VDC (ArcLink ®)	
Current Draw @ 60Hz Input	3.8 Amps 115 VAC .5 Amps 40 VDC	
Maximum Operating Pressure and Flow Rate (Open Flow, Without Welding Torch Restriction)	60 psi (414 kPa) (4.14 bar)Max. 1.66 gal/min. (6.28 liter/min) Max.	
Typical Operating Pressure and Flow Rate (With Welding Torch Restriction)	53-57 psi (365-393 kPa) .45-.60 gal/min. (1.7-2.3 liter/min)	
Reservoir Size	2.375 gal. (9 liters)	
Recommended Coolant	<b>For Use Above Freezing:</b> Clean tap, distilled or de-ionized water.	
	<b>For Use Below Freezing:</b> 50% water and 50% pure ethylene glycol (reagent or industrial grade) mixture.	
	<p><b>DO NOT USE:</b> Automotive anti-freeze that contains rust inhibitors or leak stoppers. These coolants will damage the pump and block the small internal passageways of the heat exchanger, affecting cooling performance. To acquire the proper coolant contact a local welding distributor.</p> <p><b>DO NOT USE:</b> Pre-packaged welding industry coolants <sup>◇</sup>. These coolants may contain oil-based substances, which attack the plastic components of the cooler. Once added to the cooler, these substances are virtually impossible to purge from the water lines and heat exchanger.</p> <p><sup>◇</sup>Magnum Pro AL coolant may be used.</p>	
Weight	Shipping	64 lbs (29 kg)
	Reservoir Full (Water)	83.7 lbs (38 kg)
Dimensions	L	26.5 in. (673.1mm)
	W	13.9 in. (353.0mm)
	H (Top Face)	11.5 in. (292.1mm)
EMC Classification	Category 1	
Temperature Range	14°F to 104°F (-10°C to 40°C)	

\*Cooling Power is measured at a 1 L/min. flow rate with a 40°C coolant temperature rise in a 25°C (77°F) environment.

### EXPLANATION OF SYMBOLS THAT APPEAR ON THIS EQUIPMENT



**ArcLink®  
STATUS**



**COOLANT  
OUT  
COOLANT  
IN**



COOL ARC® 55 S



## SAFETY PRECAUTIONS

### ⚠ WARNING



#### ELECTRIC SHOCK can kill.

- Only qualified persons should perform this installation.
- Turn off the power source at the disconnect switch before connecting or working inside of the equipment.
- Use only grounded receptacle.
- Do not remove the power cord ground prong.



#### HOT COOLANT CAN BURN SKIN

- Always be sure coolant is not hot before doing any work on cooler parts.



#### ROTATING FAN BLADES ARE HAZARDOUS

- Do not put your hands near operating fan.
- Keep all equipment safety guards, covers and devices in position and in good repair. Keep hands, hair, clothing and tools away from V-belts, gears, fans and all other moving parts when starting, operating or repairing equipment.
- In some cases it may be necessary to remove safety guards to perform required maintenance. Remove guards only when necessary and replace them when the maintenance requiring their removal is complete. Always use the greatest care when working near moving parts.

## UNPACKING THE COOL ARC® 55 S

The packaging of the Cooler is designed to withstand shipping abuse, and contains a cardboard liner that surrounds the unit. If any shipping damage has occurred, contact your certified Lincoln distributor or service center. When unpacking the unit, avoid thrusting sharp objects through the carton liner, which may puncture the plastic reservoir. Save the instruction manual and service directory supplied with the COOL ARC® 55 S for parts orders and future maintenance service.

**Read this entire installation section before you start installation.**

## INSTALLATION ON POWER SOURCE

The COOL ARC® 55 S is designed to mount directly to the bottom of a Power Wave “S” series power source.

Always place the COOL ARC® 55 S on a level surface to avoid causing the machine to topple over.

## LOCATION AND MOUNTING

(See Figure A.1)

To mount the COOL ARC® 55 S to the bottom of a compatible Power Wave® “S” series power source utilize the quick lock mechanism as shown.

If using the COOL ARC® 55 S in conjunction with another module such as the STT® Module, always mount the COOL ARC® 55 S on the bottom. The COOL ARC® 55 S will operate in harsh environments and can be used outdoors. It is important that simple preventative measures are followed in order to assure long life and reliable operation.

- The machine must be located where there is free circulation of clean air such that movement into and out of the louvers will not be restricted.
- Dirt and dust that can be drawn into the machine should be kept to a minimum. The use of air filters on the air intake is not recommended because normal air flow may be restricted. Failure to observe these precautions can result in poor cooling performance.
- Keep the machine dry. Shelter from rain and snow. Do not place on wet ground or in puddles.
- Always mount the COOL ARC® 55 S underneath other machines. **Never attach a module underneath the cooler.**
- Do not mount the Power Wave® “S” series power source and COOL ARC® 55 S combination over combustible surfaces. Where there is a combustible surface directly under stationary or fixed electrical equipment, that surface shall be covered with a steel plate at least .060” (1.6mm) thick, which shall extend not less than 5.90” (150mm) beyond the equipment on all sides.
- Avoid placing the cooler near areas of extreme heat.
- Avoid placing the cooler near a flux hopper or an area where dust build-up is extreme.

FIGURE A.1

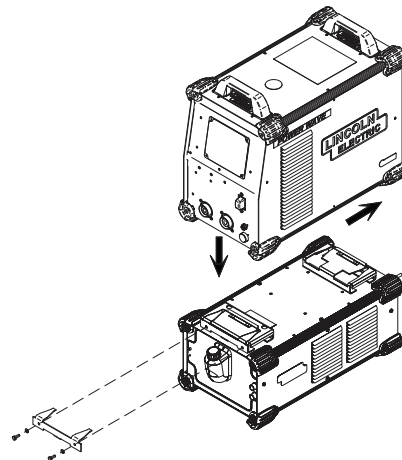

COOL ARC® 55 S





**FILLING THE COOLANT RESERVOIR:****Recommended Coolant**

- For Use Above Freezing: Clean tap, distilled or de-ionized water.
- For Use Below Freezing: 50% water and 50% pure ethylene glyco (reagent or industrial grade) mixture.
- **DO NOT USE:** Automotive anti-freeze that contains rust inhibitors or leak stoppers.  
These coolants will damage the pump and block the small internal passageways of the heat exchanger, affecting cooling performance.
- **DO NOT USE:** Pre-packaged welding industry coolants. These coolants may contain oil-based substances, which attack the plastic components of the cooler. Once added to the cooler, these substances are virtually impossible to purge from the water lines and heat exchanger.

To avoid freeze damage and water leakage in shipment, the COOL ARC® 55 S unit is delivered empty with no coolant in the system. To fill the unit, locate the plastic screw on reservoir fill cap at the front of the unit and remove by turning counter-clockwise.

Clean tap water, distilled water, de-ionized water, a 50/50 mix of pure ethylene glycol and water, or any other coolant specified by the manufacturer of the water cooled product that the Cooler is used with, can be added into the coolant reservoir. The opening of the fill cap mates with most coolant containers but, to avoid spillage of coolant, a funnel should be placed into the reservoir hole when filling the COOL ARC® 55 S.

**NOTE:** Pure solutions and mixtures of, or materials (i.e. towels) wetted with ethylene glycol are toxic to humans and animals. They must not be haphazardly discarded, especially by pouring liquids down the drain. Contact the local EPA office for responsible disposal methods or for recycling information.

For best results when using the COOL ARC® 55 S with Lincoln guns or torches, use distilled or de-ionized water, although if not available, tap water can be used. If protection from freezing is desired, use a 50% water and 50% pure ethylene glycol (reagent or industrial grade) mixture. An alcohol and water mixture is also acceptable.

When using the COOL ARC® 55 S with other products, consult the manufacturer's instruction manual for recommended coolants.

**⚠ CAUTION**

**DO NOT USE OIL BASED COOLANTS OR COOLANTS THAT CONTAIN RUST INHIBITORS OR LEAK STOPPERS.**

**UNPLUG THE COOLER BEFORE FILLING THE COOLANT RESERVOIR:**

Carefully add 2.375 gallons (9 liters) of coolant through a funnel into the coolant reservoir fill hole.

The cooler is "FULL" when the coolant lies just below the coolant reservoir opening .

**NOTE: DO NOT ADD MORE THAN 2.375 GALLONS (9 LITERS) OF COOLANT INTO THE RESERVOIR.** The fill cap contains a pressure release air hole, which must not be blocked by overfilling the reservoir with coolant.

Be certain to replace the reservoir fill cap when the reservoir is full. Operation of the COOL ARC® 55 S without the fill cap in place can cause poor cooling efficiency, evaporation loss of coolant and reduced product life.

## COOLANT "IN" AND "OUT" CONNECTIONS

The fittings located on the COOL ARC® 55 S are two female **Quick Disconnect fittings**. These mate with water hoses typically used in the welding industry. Two couplers converting from quick disconnect to 5/8-18 left-hand thread (CGA style) are also included.

Refer to **Figure A.2**.

### Water or Coolant Line Connections to the COOL ARC® 55 S

Take the male quick disconnect of the water hose and check if it matches the coupler or the quick disconnect on the front of the unit. When using water hoses with threaded nuts use the supplied couplers to convert from 5/8-18 left hand male thread to male quick disconnect.

**(Reference FIG. A.2)** Take the accessory "INLET" hose (colored or tagged blue on most hoses) and plug it into the coolant "OUT" fitting located on the front of the cooler. If necessary use the supplied coupler, making sure to secure the connector nut of the hose tightly into the fitting with a wrench so that leaking does not occur. Then take the accessory "OUTLET" hose (colored or tagged red on most hoses) and plug it into the coolant "IN" fitting located on the front of the cooler. Again, if necessary use the coupler, tightly securing the connector nut of the hose into the fitting with a wrench to ensure that no leaking occurs.

**NOTE: BE CERTAIN THAT NO LEAKS EXIST WHEN THE COOLER IS TURNED ON. A LEAK WILL DEplete RESERVOIR VOLUME, CAUSING POOR COOLING PERFORMANCE AND REDUCING GUN OR TORCH LIFE.**

## INPUT POWER CONNECTION

Plug the input power cord on the COOL ARC® 55 S into a standard 115V NEMA circuit breaker protected receptacle. The receptacle must have overload protection and a grounding conductor pin.

## ArcLink® CONNECTIONS

The pigtail connection on the COOL ARC® 55 S includes signal and power lines required for proper operation. With the COOL ARC® 55 S securely fastened to the power source, connect the pigtail to its respective 5 pin receptacle on the back of the power source. The ArcLink receptacle on the back of the COOL ARC® 55 S should be used for connection to compatible wire feeders. Best results will be obtained when control cables are routed separately from the welding cables. It is recommended that the total combined length of the ArcLink control cable network does not exceed 200 ft. (61m).

**FIGURE A.2**

Inlet and Outlet Hose Connection Diagram

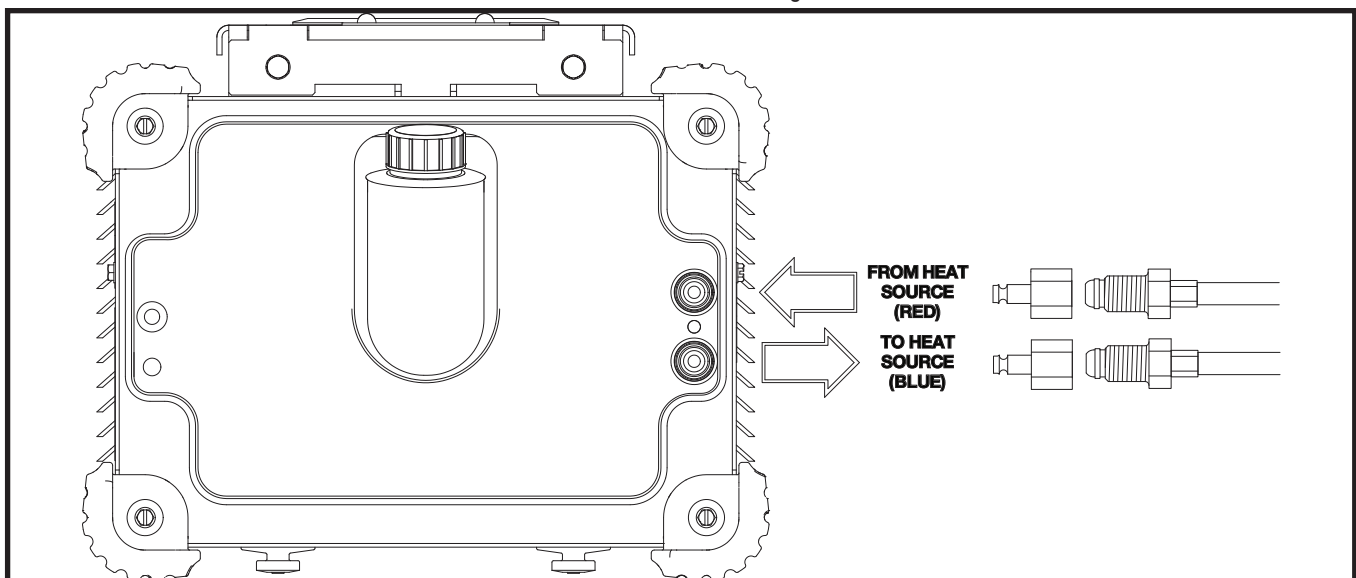

COOL ARC® 55 S

**LINCOLN**  
ELECTRIC

## INSTALLATION OF WATER COOLED ACCESSORIES

After following the installation instructions above, the COOL ARC® 55 S is ready for connection to a water-cooled accessory.

### WATER COOLED TIG TORCH AND MIG GUN

Follow **Figure A.3** when using the COOL ARC® 55 S with water-cooled TIG torches. Follow **Figure A.5** when using the COOL ARC® 55 S with water-cooled MIG gun. Consult the manufacturer's instruction manual when using the COOL ARC® 55 S with other water-cooled TIG and MIG accessories.

### CONNECTION TO WIRE FEEDERS

Follow **Figure A.4** when using the COOL ARC® 55 S in conjunction with a wire feeder. The feeder will need to have pass-through water hoses installed in order to correctly function with the COOL ARC® 55 S, since the cooler requires continuous flow. **DO NOT USE A WATER SOLENOID VALVE** with the COOL ARC® 55 S. Water pass-through connection kits are available for wire feeders. Refer to product literature or the wire feeder's instructions manual for kit availability and further connection details. It is not required to run the water lines through the wire feeder, but it does provide a very neat MIG gun connection. If pass-through water hoses are unavailable, connect the MIG gun as shown in **Figure A.5**.

**FIGURE A.3**

Water Cooled TIG Torch Connection

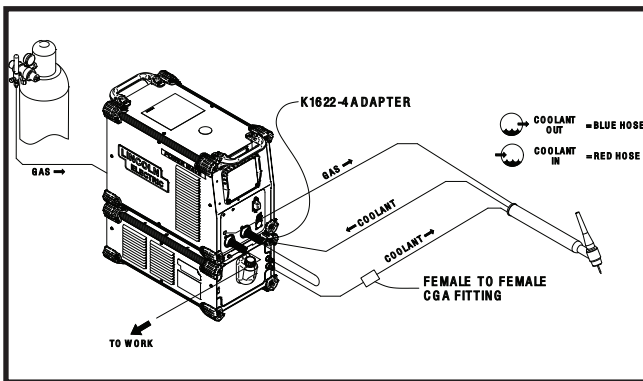

**FIGURE A.4**

Water Cooled MIG Gun Connection

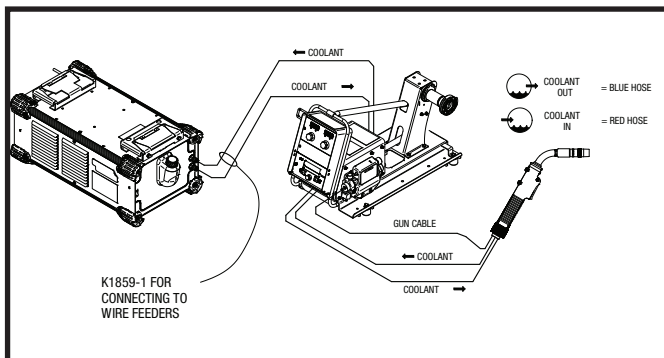

## CAUTION

**DO NOT USE A WATER SOLENOID VALVE** with the COOL ARC® 55 S. When a solenoid valve closes, the pump would dead-head, causing the pump to heat up excessively leading to premature failure of the pump.

### K529-10 POWER INPUT CABLE WITH WATER AND GAS HOSES

This cable assembly includes a (1) power cable, (1) control cable, (1) gas hose and (2) water hoses to connect a power source to a wire feeder. The cable length is 10'. The water hoses have 5/8"-18 left hand male hose fittings and the gas hose has a 5/8"-18 right hand male hose fitting. The cable and hose lengths are designed to connect a wire feeder to a COOL ARC® 55 S. Refer to **Figure A.6** for an illustration of this connection.

**FIGURE A.5**

Connection to Wire Feeder (Do Not Use Water Solenoid)

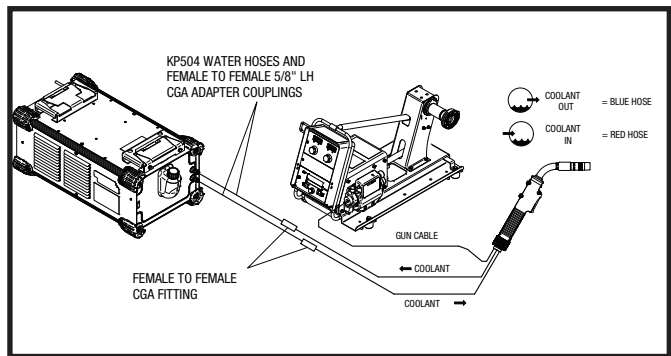

**FIGURE A.6**

Connection to Wire Feeder (Do Not Use Water Solenoid)

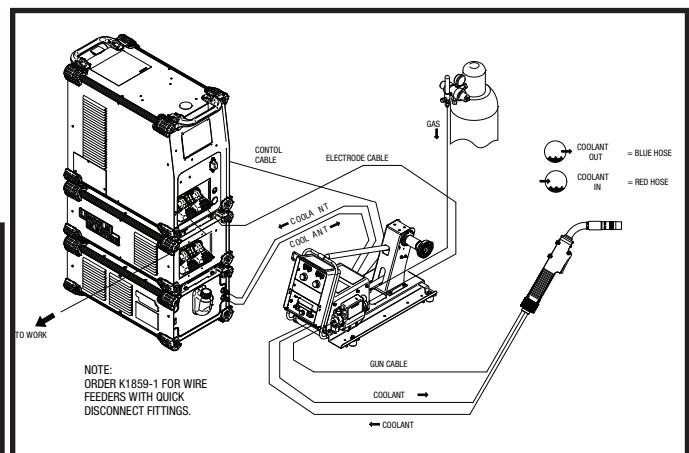

COOL ARC® 55 S

**LINCOLN**  
ELECTRIC

## SAFETY PRECAUTIONS

### ⚠ WARNING



**ELECTRIC SHOCK** can kill.

- Do not operate with covers removed.
- Do not operate if cables are wet or immersed in water.



• Moving parts can injure. Never place fingers into openings of Cooler.



• Hot coolant can burn skin. Always be sure coolant is **NOT HOT** before servicing the cooler.



• Do not pour used ethylene glycol coolant down the drain.

See additional warning information at front of this operator's manual.

## PRODUCT DESCRIPTION

The COOL ARC® 55 S is a re-circulation cooling system designed for use with water-cooled TIG, MIG, PAC (Plasma Arc Cutting) and PAW (Plasma Arc Welding) guns and torches. The COOL ARC® 55 S is designed for use with S series power sources and requires 115 VAC power input and an ArcLink® connection. The cooler will communicate via ArcLink® with the wire feeder and power source to automatically turn on when welding is taking place, and off a few minutes after welding.

The COOL ARC® 55 S is equipped with a flow sensor to only allow welding to occur when coolant is flowing. When a low or no flow condition is sensed, welding will be shut down to protect valuable torches and guns.

Adding coolant to the reservoir is simple and connecting to the coolant "IN" and "OUT" connections are easily made by hand with the quick disconnects.

The COOL ARC® 55 S coolant flow is circulated through a heat exchanger to remove heat energy from the coolant. The coolant flow is then deposited into the coolant reservoir. The pump draws its coolant supply from the coolant reservoir and delivers coolant to the welding torch or gun. Refer to **Figure B.1** and **B.2**

## POWER-UP SEQUENCE

The COOL ARC® 55 S will be powered up at the same time as the power source. The status light will blink green for about a minute while the system is configuring. After this time, the status lights will turn a steady green indicating the machine is ready.

The pump and fan in the COOL ARC® 55 S will run only when welding begins, or while holding the switch on the front of the unit.

## RECOMMENDED PROCESSES AND EQUIPMENT

The COOL ARC® 55 S is designed for use with water-cooled TIG, MIG, PAC (Plasma Arc Cutting) and PAW (Plasma Arc Welding) guns and torches. The COOL ARC® 55 S can be used with MIG wire feeders and S series power sources.

## COMMON EQUIPMENT PACKAGES

K3086-2	COOL ARC® 55 S
K2823-3	POWER WAVE® S350
K2230-1	POWER FEED® 10M
K1543-XX	ArcLink® CABLE (5 PIN ) - connects wire feeder to cooler.

## TURNING THE SYSTEM "ON"

After connecting the COOL ARC® 55 S per the installation instructions above, plug the unit into a 115V NEMA electrical receptacle for start-up operation. Be certain that the power input into the unit matches the Cooler's rated input.

Although the cooler is designed to turn on/off as needed while welding, for initial setup and when installing a new gun you will first need to fill the system with coolant. This can be done by using the momentary switch on the front of the unit. Remove the fill cap and hold the switch down until you see coolant return into the tank. The system is now primed and ready for use.

You will be able to hear the fan running and feel air-flow out of the sides of the unit when the cooler is operating.

COOL ARC® 55 S



The coolant FLOW INDICATOR is accessed by removal of the fill cap. Actual return flow is directly visible, via the fill opening.

When first starting the unit, check all of the coolant hoses to ensure that no water leaks are present. Water leakage causes poor welding performance, poor cooling performance, low welding component life and potential electrical safety hazards.

- The cooler will automatically turn "ON" when the trigger is pulled.
- The cooler will automatically turn "OFF" when welding is not taking place for long periods of time.
- The manual control switch on the front of the cooler can be used to run the cooler without the "smart" features. This should be used to prime the system on initial setup and when changing guns.
- Never operate the cooler with the reservoir fill cap removed. Unless checking coolant flow.

- Avoid kinking or putting sharp bends in any water lines.
- Keep all water lines clean and free of any blockage.
- Do not operate cooler without coolant in reservoir. Never run pump dry.

**COOLING EFFICIENCY**

The high cooling efficiency of the COOL ARC® 55 S offers a cooler, more comfortable weld than conventional air-cooled procedures as well as leading competitors water cooled systems.

The COOL ARC® 55 S effectively removes the heat of the arc away from the gun or torch handle and places it into the exiting air flow at the sides of the cooler. Ambient air temperature affects the coolant temperature of the COOL ARC® 55 S.

**FIGURE B.1**  
Coolant Circulation Diagram

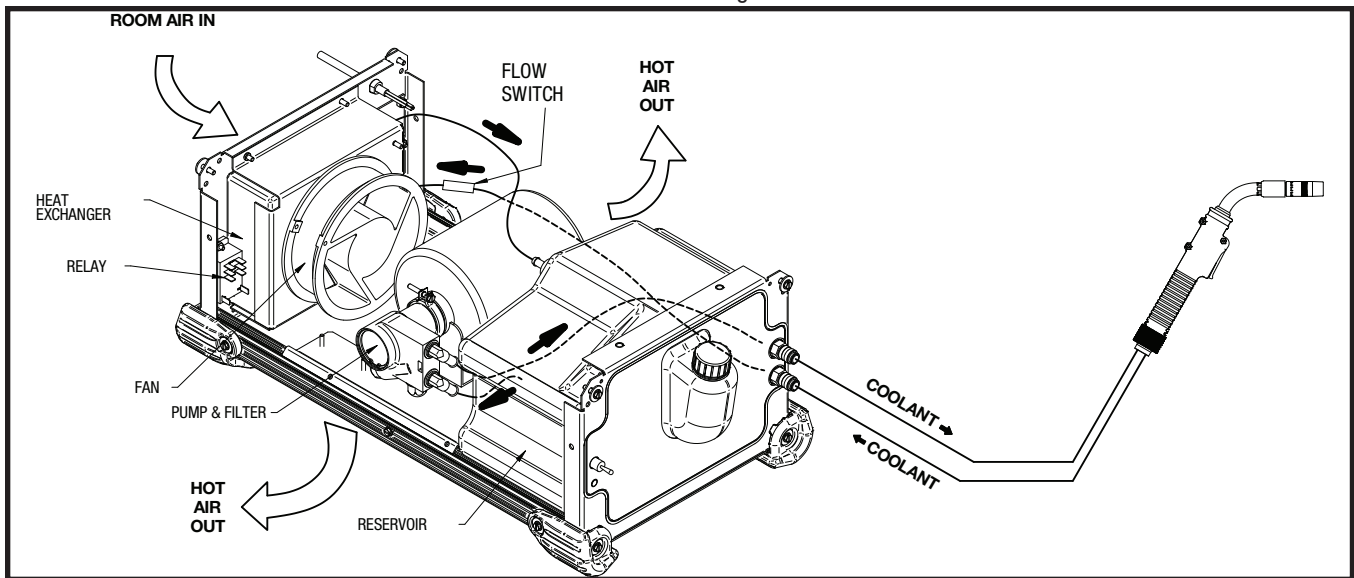

**FIGURE B.2**

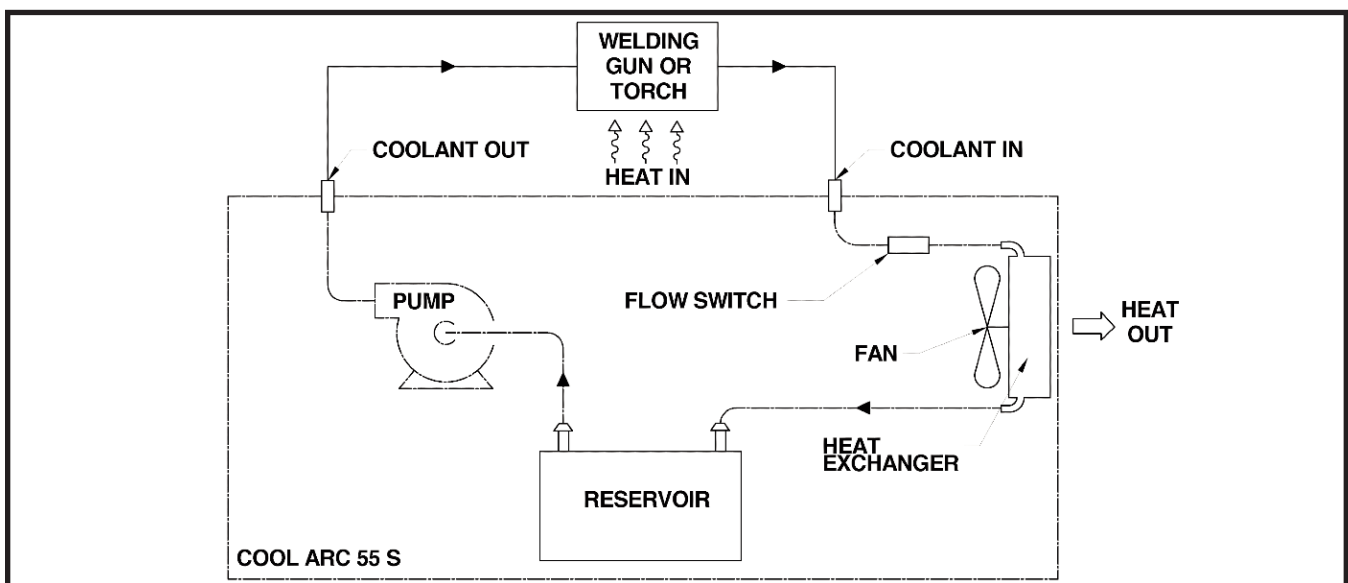

## EQUIPMENT LIMITATIONS

The COOL ARC® 55 S is intended for use with compatible medium range “S” – series POWER WAVE® power sources such as the S350 and S500.

## CASE FRONT DESCRIPTIONS (See Figure B.3)

**1. Status LED** – Provides ArcLink® status of COOL ARC® 55 S .

**Note:** During normal power-up, the LED will flash green up to 60 seconds as the equipment performs self tests.

LED condition	Definition
Steady green.	System okay. The power source and wire feeder are communicating normally.
Blinking green.	Occurs during a reset and indicates the power source is identifying each component in the system. This is normal for the first 60 seconds after power-up, or if the system configuration is changed during operation.
Alternating green and red .	Non-recoverable system fault. If the power source or wire feeder status LED is flashing any combination of red and green, errors are present in the system. Read the error code before the machine is turned off.

**2. MANUAL OPERATION SWITCH** - Allows you to manually run the cooler without the ArcLink® communications or while you are not welding. On initial setup and when changing guns, you should use this switch to fill the system with coolant. If you do not use this to prime the system, the flow switch inside the cooler may not close and will shut down your welding.

**3. COOLER INPUT**

**4. COOLER OUTPUT**

FIGURE B.3

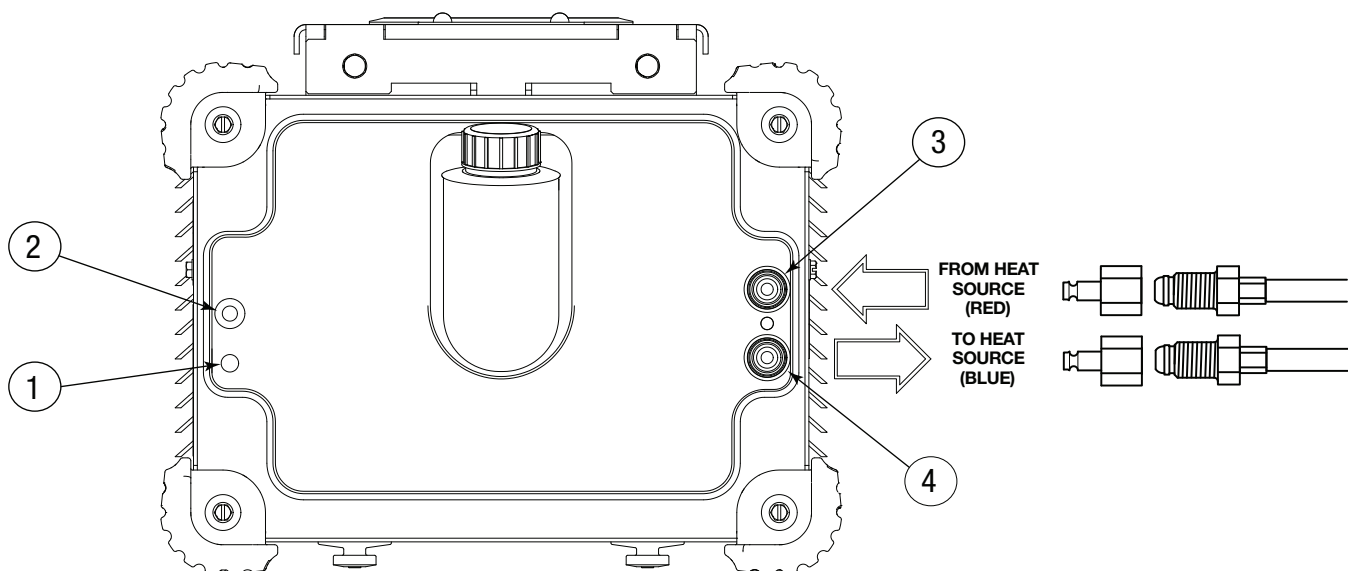



**CASE BACK DESCRIPTIONS** (See Figure B.4)

1. **115 VAC Input Cord** - Provides primary power for the pump and fan. Connect to 115VAC receptacle on the power source or other location.
2. **ArcLink® Pigtail** – Connects directly to the ArcLink® Out receptacle on the rear of the power source.
3. **ArcLink® (Out)** – Provides an ArcLink® pass through connection for all compatible ArcLink® wire feeders.

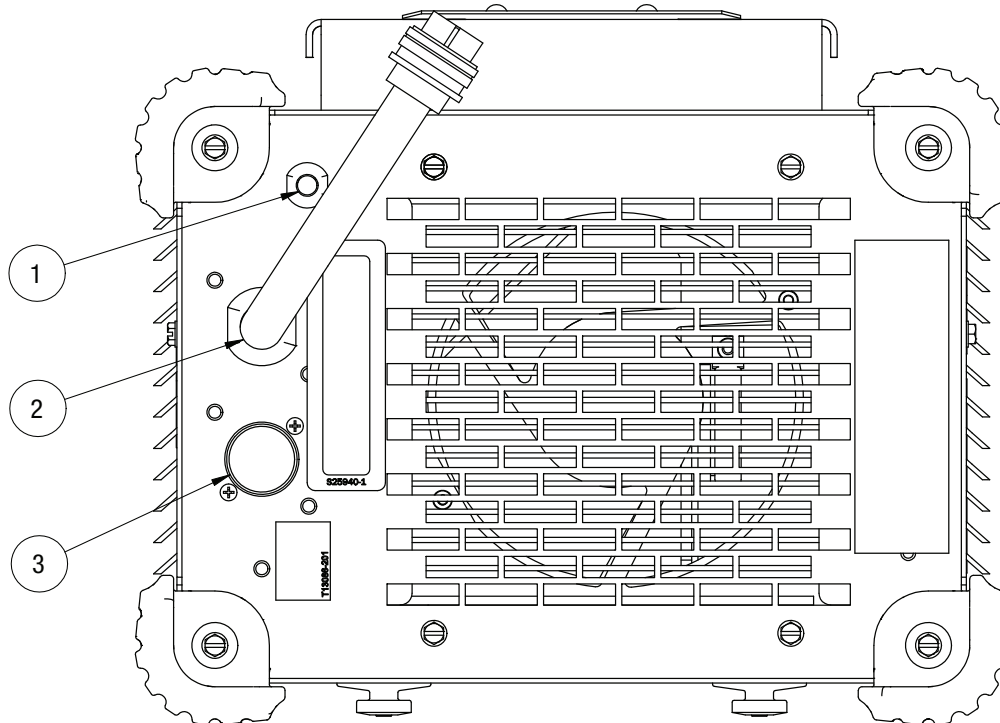
**FIGURE B.4**

**OPTIONAL EQUIPMENT (Field Installed)****K15436-xx ArcLink® Cable (5 Pin):**

Connects wire feeder to water cooler.

**KP1529-1 Quick Connect Water Adapter:**

Converts a male 5/8"-18 left hand hose fitting (CGA Style) to a female quick connect fitting. The female quick connect mates with the male quick connects on water cooled MIG guns or hoses.

**K1859-1 Water Cooler to Wire Feeder Hoses:**

This kit includes two 25'(7.6m) – 3/16 I.D. water hoses with a 5/8" LH CGA style fitting on one end and a male quick disconnect on the other. Most wire feeders have female quick disconnects and this kit allows direct hook up between the water cooler and the wire feeder.

**5/8"-18 Left Hand Male Hose Fitting Parts: (CGA Style)**

Fittings that convert a standard 3/16" I.D. hose to a 5/8"-18 left hand male hose fitting. These male hose fittings mate with the fittings on the back of the COOL ARC® 55 S.

**Order the following:**

(See Parts Lists for Item's below)

- (2) Connector Nuts
- (2) Nipples for 3/16" I.D. Hose
- (2) Hose Clamps

The connector and nipple listed fit tightly onto 5/32" (4.0mm) to 3/16" (4.8mm) inner diameter hose, but if clamped tightly to the hose, can fit up to a .25" (6.4mm) inner diameter hose. These fittings are also readily available from any industrial welding supplier.

**K529-10 Power Input Cable with Water and Gas Hoses:**

This cable assembly includes the following: (1) power cable, (1) control cable, (1) gas hose and (2) water hoses. The cable assembly connects a power source to a wire feeder for water-cooled MIG applications. The cable length is 10'(3.1m). The water hoses have 5/8"-18 left hand male hose fittings and the gas hose has a 5/8"-18 right hand male hose fitting. The cable and hose lengths are designed to connect a wire feeder to a COOL ARC® 55 S that is vertically mounted at the rear of a power source on a dual cylinder under-carriage. **Refer to Figure A.6** for an illustration of this connection.

**KP504 TIG Hook Up Kit:**

The Hook-Up Kit includes: (2) water hoses, (1) gas hose, (2) water adapter fittings, male to male 5/8" LH thread, (1) water hose coupler, female to female 5/8" LH thread and (1) power cable adapter. Threads on all hoses and fittings are CGA style.

 **CAUTION**

**DO NOT USE A WATER SOLENOID VALVE with the COOL ARC® 55 S. When a solenoid valve closes, the pump would dead-head, causing the pump to heat up excessively leading to premature failure of the pump.**

**Coolant Hoses:**

Coolant hoses are readily available from an industrial welding supplier or in various MIG or TIG hook-up kits provided by Lincoln Electric. Refer to Magnum accessory literature sheets.

For lengths of coolant hoses over 25 Ft (7.6m). and up to 50 Ft. (15.2m), 5/16 I.D. hose is recommended. 5/16 I.D. hose and accommodating fittings are available from an industrial welding supplier.

## SAFETY PRECAUTIONS

### WARNING

Have qualified personnel do the maintenance work. In some cases, it may be necessary to remove safety guards to perform required maintenance. Remove guards only when necessary and replace them when the maintenance requiring their removal is complete. Always use the greatest care when working near moving parts.



#### **ELECTRIC SHOCK can kill.**

- Do not touch electrically live parts or electrode with skin or wet clothing.
  - Insulate yourself from work and ground
  - Always wear dry insulating gloves.
- Disconnect input power by removing plug from receptacle before working inside Cooler.
  - Do not touch electrically "hot" parts inside Cooler.
  - Have qualified personnel do the installation, maintenance and troubleshooting work.
  - Unplug the cooler before performing general maintenance.



#### **MOVING PARTS can injure.**

- Do not operate with doors open or guards off.
- Keep away from moving parts.

Observe all Safety Guidelines detailed throughout this manual. Be sure to disconnect the Cooler from the Power Source before performing any maintenance

## ROUTINE MAINTENANCE

Remove accumulated dust and dirt from the internal components of the cooler by blowing it out with a low pressure air hose or removing it with a vacuum hose.

## PERIODIC MAINTENANCE

In dirty or dusty environments or if biological growth occurs in the coolant, it may be necessary to flush the coolant reservoir. Drain the old coolant, rinse the inside of the reservoir and circulate rinsing solution through the coolant system. Add new coolant when cleaning is finished. **It is recommended to flush the coolant at least once a year.** A cooling system free from debris offers increased cooling efficiency and longer pump and torch life. See the **Coolant Treatment Recommendation** in this "Maintenance Section".

**NOTE:** Pure solutions, mixtures of, or materials (i.e. towels wetted) with ethylene glycol are toxic to humans and animals. They must not be haphazardly discarded, especially by pouring liquids down the drain. Contact the local EPA office for responsible disposal methods or for recycling information.

## PUMP MAINTENANCE

The pump head has a "built in" strainer on the inlet side of the pump. **It is recommended to clean or replace the pump's inlet strainer at least once a year. (See Above):**

- Drain the coolant reservoir and all coolant lines. Dispose of the coolant properly as specified above.
- Hold the pump head firmly to apply a counter-torque when loosening the strainer's 7/8" acorn nut located on the bottom. Do not confuse with 3/4" acorn nut. Remove nut and slide inlet strainer down and out from the pump head.
- Gently rinse the strainer under running water to thoroughly clean it.
- Use a mirror to inspect the inside of the pump for contamination. Carefully remove hardened debris with a dental pick if necessary, without scratching the inside of the pump.
- Reinstall the strainer and 7/8 acorn nut, tightening with 75+/- 15 in-lbs. of torque. Wipe dry all area wetted with coolant. Dispose of coolant soaked towels properly as specified above.
- For a more in depth procedure, See "Maintenance Section", "Pump Inlet Strainer".

## HEAT EXCHANGER

To maintain maximum cooler efficiency, the heat exchanger should be kept free of dust and dirt build-up. Clean the heat exchanger periodically using a vacuum hose or a low-pressure air line. Avoid placing the unit near a flux hopper or a flux waste container. A clean heat exchanger offers better cooling performance and longer product life. In extremely dirty environments, it may be necessary to remove the heat exchanger completely from the cooler and clean the fins with soap and water. Use care to avoid damaging the fins.

## RESERVOIR COOLANT LEVEL

The reservoir volume should be checked daily before using the cooler. Remove the reservoir fill cap and check the coolant level. The reservoir is full when the coolant level is just below the reservoir fill opening. Keep the reservoir full, especially after disconnecting the water lines or changing the accessory being cooled.

## COOLANT TREATMENT RECOMMENDATION

This procedure is intended to provide a means of reducing the objectionable amount of fungal and bacterial contamination that has occurred in COOL ARC® 55 S water coolers and cooling systems.

### Additive:

The recommended additive can be purchased at local pool supply stores. An example is "Maintain Pool Pro 30% Non-Foam Algaecide"

### Limitations:

- This additive should be used with fresh coolants containing only pure water.
- This additive should not be used with coolants containing any other substance, including antifreeze substances.
- No other additives shall be used with the specified coolant that has been treated with the recommended additive.
- This procedure is no permanent substitute for a periodic maintenance schedule for the specified coolers
- A 1 quart bottle of additive is sufficient to disinfect and treat about 500 coolers.
- **Check with the manufacturer of your guns or torches to be sure that this procedure is compatible with your equipment.**

### Prepare the disinfectant:

Make a quantity of only what is needed to avoid an excess Bulk preparation (for coolers serviced in quantity):

2.75 gals. (10.41 liters) of pure, fresh water per cooler  
1.922 ml of additive per cooler. Example: for 100 coolers, add 192.2 ml to 275.0 gals. of pure fresh water. Pour 2.375 gals. (9 liters) of disinfectant into the empty reservoir. Recap the reservoir, tape over the air vent in the cap, roll disinfectant around the inside the reservoir to thoroughly coat all of its surfaces. Remove the tape from the reservoir cap. Prime the cooling system by positioning cooler horizontally and circulate disinfectant through it for 10 to 15 minutes. Drain disinfectant from the cooling system. Do not reuse this solution. Add new, fresh coolant to the cooling system. Add 0.375 gals. (1.42 liters) of fresh disinfectant to the system by pouring it into the reservoir, then reduce the concentration to the nominal 30 ppm:

Add the balance 2.0 gals. (7.55 liters) of fresh, pure water to the reservoir to create the treated coolant concentration. Prime the cooling system.

Check coolant level. Add more fresh, pure water if required, without adding more than 0.125 gal. (0.475

## PUMP INLET STRAINER

Poor cooler performance can usually be traced to a partially or completely blocked pump inlet strainer. This is a user-serviceable item and can be cleaned and reused, or replaced. Continued pump operation with a blocked strainer can cause:

- Voiding of cooler service warranty
- Cavitation damage to the pump head's inlet areas
- Welding accessory damage from overheating due to insufficient coolant flow rate.

A new or properly cleaned pump inlet strainer should restore the cooler's performance.

For additional service and periodic maintenance details and for recommended coolants, follow the recommendations listed below.

### Procedure and Preparation:

## WARNING

- **Always switch off the COOL ARC® 55 S machine power**
- **Always disconnect the COOL ARC® 55 S machine from service input power.**
- **Always allow the coolant in the system to cool enough to avoid burn injuries.**
- **Avoid contact with contaminated coolant. Wear waterproof gloves and protective eye wear.**
- **Do not remove the pump relief valve's 3/4 in. acorn hex nut or attempt to adjust the relief valve setting.**

## INSPECT CONDITION OF COOLANT

If coolant is contaminated or old:

- Drain the system of coolant and dispose of it in an environmentally responsible manner.
- Flush system of old coolant.
- Fill with fresh tap or distilled water, run for ten minutes, and drain.
- Proceed to adding coolant..

If coolant is clean and fresh:

- If clean, dedicated coolant handling equipment, including a clean siphon pump and a clean holding tank are available then proceed to servicing the Pump Inlet Strainer.

**Removing Coolant:**

- a. Drain coolant from the reservoir using clean siphoning equipment
- b. Coolant level should be drained below the strainer's pressure fitting:
  - This prevents coolant from streaming out of unit when strainer nut is removed

**SERVICE THE PUMP'S INLET STRAINER:**

- a. Remove all power to the unit (115VAC and ArcLink®). Place absorbent towels underneath pump head to prevent stray coolant from wetting cooler's electrical components.
- b. See figure D.1. Hold pump head to apply counter-torque when loosening strainer's 7/8 acorn nut. Do not confuse with 3/4 acorn nut. Remove nut and slide inlet strainer down and out from pump head.
- c. Inspect strainer for damage or excessive clogging:
  - Replace or Gently rinse strainer under running water to thoroughly clean it.
- d. Use a mirror to inspect inside of pump for contamination. If hardened debris is present and interferes with filter seating, carefully remove it with dental pick without scratching inside of the pump. Use care not to drop debris into pump.
- e. Reinstall strainer and acorn nut, tightening with  $75 \pm 15$  in.-lbs. of torque.
  - Hold pump head to apply counter-torque when loosening strainers 7/8 acorn nut.

- f. Wipe dry all areas wetted by coolant. Dispose of towels in an environmentally responsible manner.

**Add coolant:**

- a. Add 2.375 gallons of coolant, either the recommendations off the water cooled accessory or if none, see the design specification summary listed in this manual.

**ADDITIONAL SERVICE NOTES:**

1. Always use a back-up wrench on pump head when loosening or tightening pump fittings.
2. Never run the pump dry. Always use a recommended coolant, otherwise pump damage may result.
3. **Flush coolant from system and replace with fresh, recommended coolant at least once a year. More frequent flushing may be necessary, depending upon the user's particular system or its usage, especially if it is prone to clogging from biological growth in the coolant.**

**FIGURE D.1**

COOL ARC® 55 S

**LINCOLN**  
 ELECTRIC



---

**HOW TO USE TROUBLESHOOTING GUIDE****⚠ WARNING**

Service and Repair should only be performed by Lincoln Electric Factory Trained Personnel. Unauthorized repairs performed on this equipment may result in danger to the technician and machine operator and will invalidate your factory warranty. For your safety and to avoid Electrical Shock, please observe all safety notes and precautions detailed throughout this manual.

This Troubleshooting Guide is provided to help you locate and repair possible machine malfunctions. Simply follow the three-step procedure listed below.

**Step 1. LOCATE PROBLEM (SYMPTOM).**

Look under the column labeled “PROBLEM (SYMPTOMS)”. This column describes possible symptoms that the machine may exhibit. Find the listing that best describes the symptom that the machine is exhibiting.

**Step 2. POSSIBLE CAUSE.**

The second column labeled “POSSIBLE CAUSE” lists the obvious external possibilities that may contribute to the machine symptom.

**Step 3. RECOMMENDED COURSE OF ACTION**

This column provides a course of action for the Possible Cause, generally it states to contact your local Lincoln Authorized Field Service Facility.

If you do not understand or are unable to perform the Recommended Course of Action safely, contact your local Lincoln Authorized Field Service Facility.

**⚠ CAUTION**

If for any reason you do not understand the test procedures or are unable to perform the tests/repairs safely, contact your **Local Lincoln Authorized Field Service Facility** for technical troubleshooting assistance before you proceed.

---



## USING THE STATUS LED TO TROUBLESHOOT SYSTEM PROBLEMS

The COOL ARC® 55 S is equipped with a Status Light. If a problem occurs it is important to note the condition of the status lights. **Therefore, prior to cycling power to the system, check the power source status light for error sequences in Table E.1.**

TABLE E.1

Light Condition	Meaning
Steady Green	System OK. Power source is operational, and is communicating normally with all healthy peripheral equipment connected to its ArcLink® network.
Blinking Green	Occurs during power up or a system reset, and indicates the power source is mapping (identifying) each component in the system. Normal for first 1-30 seconds after power is turned on, or if the system configuration is changed during operation.
Fast Blinking Green	Under normal conditions indicates Auto-mapping has failed. Also used by the diagnostic utility (included in the Weld Manager® Utilities available at <a href="http://www.powerwavesoftware.com">www.powerwavesoftware.com</a> ) to identify the selected machine when connecting to a specific IP address.
Alternating Green and Red	<p>Non-recoverable system fault. If the Status lights are flashing any combination of red and green, errors are present. <b>Read the error code(s) before the machine is turned off.</b></p> <p>Error Code interpretation through the Status light is detailed in the Service Manual. Individual code digits are flashed in red with a long pause between digits. If more than one code is present, the codes will be separated by a green light. Only active error conditions will be accessible through the Status Light.</p> <p>Error codes can also be retrieved with the diagnostics utility (included in the Weld Manager® Utilities available at <a href="http://www.powerwavesoftware.com">www.powerwavesoftware.com</a>). This is the preferred method, since it can access historical information contained in the error log. To clear the active error(s), turn power source off, and back on to reset.</p>
Steady Red	Not applicable.
Blinking Red	Not applicable.

### CAUTION

If for any reason you do not understand the test procedures or are unable to perform the tests/repairs safely, contact your **Local Lincoln Authorized Field Service Facility** for technical troubleshooting assistance before you proceed.

COOL ARC® 55 S



Observe all Safety Guidelines detailed throughout this manual

### ERROR CODES FOR THE COOL ARC® 55 S

The following is a partial list of possible error codes for the COOL ARC® 55 S.

COOL ARC® 55 S	
Error Code #	Indication
92      Flow Sensor Fault	The flow sensor is not detecting proper flow. Check to make sure all hoses are connected and that there is enough coolant in the system. Be sure the system is primed as described in the "Turning the System On" ( <b>Operation Section</b> ). Also there could be a blocked line or a pump failure.
(Other	A complete list of error codes is available in the Power Wave Manager Utility (available at <a href="http://www.powerwavesoftware.com">www.powerwavesoftware.com</a> ).  Error codes that contain three or four digits are defined as fatal errors. These codes generally indicate internal errors on the COOL ARC® 55 S Status PC Board. If cycling the input power on the machine does not clear the error, contact the Service Department.

### CAUTION

If for any reason you do not understand the test procedures or are unable to perform the tests/repairs safely, contact your **Local Lincoln Authorized Field Service Facility** for technical troubleshooting assistance before you proceed.

COOL ARC® 55 S



Observe all Safety Guidelines detailed throughout this manual

PROBLEMS (SYMPTOMS)	POSSIBLE CAUSE	RECOMMENDED COURSE OF ACTION
Cooler does not operate. Error 92 on cooler.(See below)	<ol style="list-style-type: none"> <li>1. Input cord unplugged.</li> <li>2. Power harness damaged.</li> <li>3. Water lines blocked, crimped or disconnected.</li> <li>4. Leak in gun or water hoses.</li> <li>5. Coolant reservoir empty.</li> <li>6. The system needs to be primed.</li> </ol>	<p>If all recommended possible areas of misadjustment have been checked and the problem persists, <b>Contact your local Lincoln Authorized Field Service Facility.</b></p>
Internal water leak.	<ol style="list-style-type: none"> <li>1. Hose clamp loose on one of internal hoses.</li> <li>2. Internal hose punctured.</li> <li>3. Heat exchanger leaking.</li> <li>4. Pump seal is leaking.</li> </ol>	
Torch or gun runs hot.	<ol style="list-style-type: none"> <li>1. Unit placed by area of extreme heat.</li> <li>2. Low coolant flow.</li> <li>3. No coolant flow. (Arclink cable unplugged).</li> <li>4. Fan not operating.</li> <li>5. Heat exchanger clogged.</li> </ol>	
Fan operates but there is low coolant flow.	<ol style="list-style-type: none"> <li>1. Leak in torch/gun or hoses.</li> <li>2. Torch/gun or hoses partially obstructed.</li> <li>3. Reservoir empty or very low.</li> <li>4. Pump strainer is dirty.</li> </ol>	
Fan operates but there is no coolant flow.	<ol style="list-style-type: none"> <li>1. Pump or pump motor failure.</li> <li>2. Pump strainer is blocked.</li> </ol>	
Pump operates, but fan does not. Cooler trips outlet circuit breaker.	<ol style="list-style-type: none"> <li>1. Loose or disconnected fan lead.</li> <li>2. Obstruction in fan blade.</li> <li>3. Fan motor failure.</li> </ol>	
Cooler trips outlet circuit breaker.	<ol style="list-style-type: none"> <li>1. Circuit overloaded.</li> <li>2. Fan or pump motor failure.</li> </ol>	
Error 92.	<ol style="list-style-type: none"> <li>1. Flow switch not closing within several seconds of welding.</li> <li>2. Make sure hoses are properly connected and coolant is returning to the cooler.</li> </ol>	

 **CAUTION**

If for any reason you do not understand the test procedures or are unable to perform the tests/repairs safely, contact your **Local Lincoln Authorized Field Service Facility** for technical troubleshooting assistance before you proceed.

COOL ARC® 55 S



WIRING DIAGRAM - COOL ARC® 55 S - Code 11949

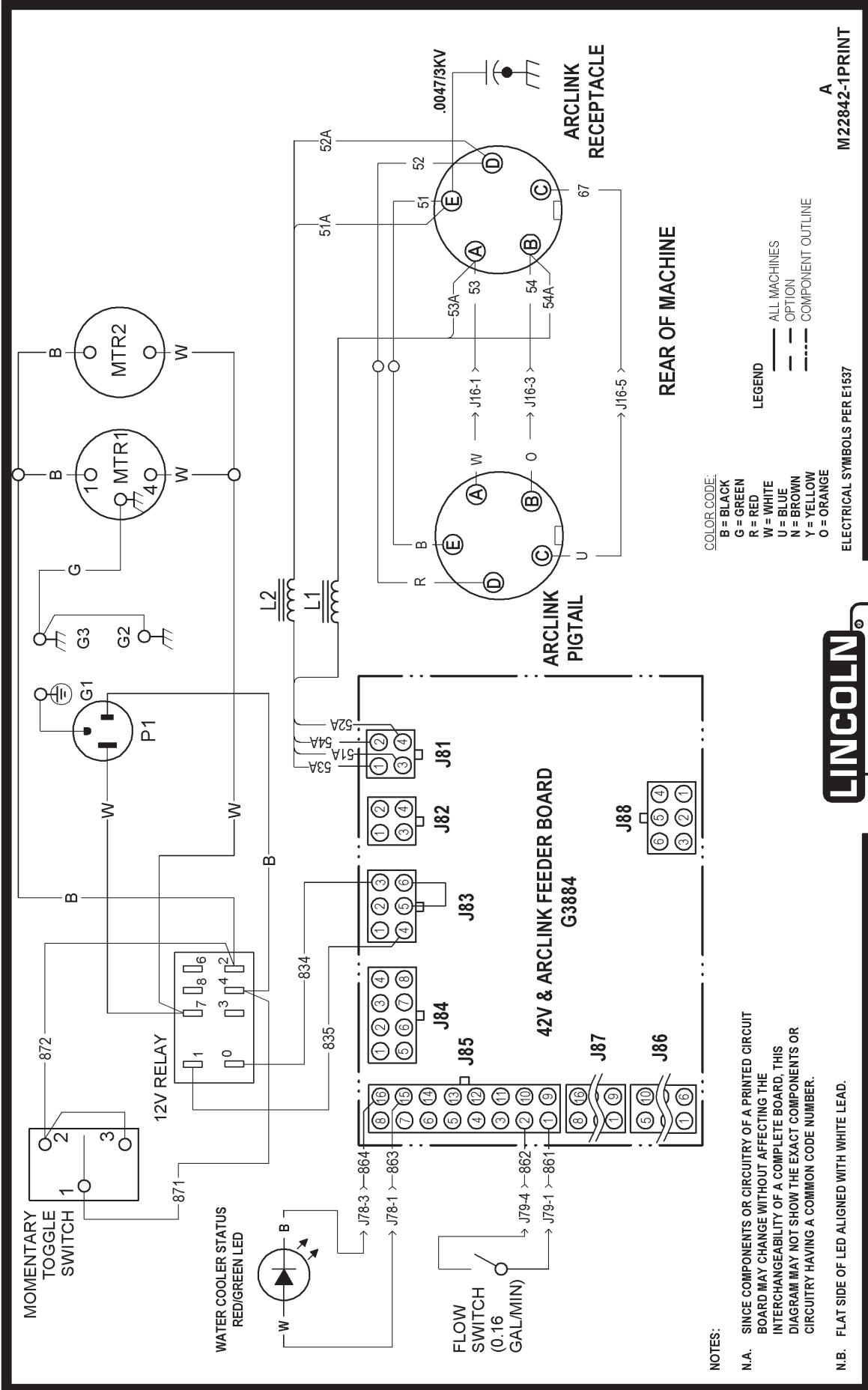

M22842-1PRINT



CLEVELAND, OHIO U.S.A.

- NOTES:**
- N.A. SINCE COMPONENTS OR CIRCUITRY OF A PRINTED CIRCUIT BOARD MAY CHANGE WITHOUT AFFECTING THE INTERCHANGEABILITY OF A COMPLETE BOARD, THIS DIAGRAM MAY NOT SHOW THE EXACT COMPONENTS OR CIRCUITRY HAVING A COMMON CODE NUMBER.
  - N.B. FLAT SIDE OF LED ALIGNED WITH WHITE LEAD.

NOTE: This diagram is for reference only. It may not be accurate for all machines covered by this manual. The specific diagram for a particular code is pasted inside the machine on one of the enclosure panels. If the diagram is illegible, write to the Service Department for a replacement. Give the equipment code number.

# DIAGRAMS

## WIRING DIAGRAM - COOL ARC® 55 S - Code 12889

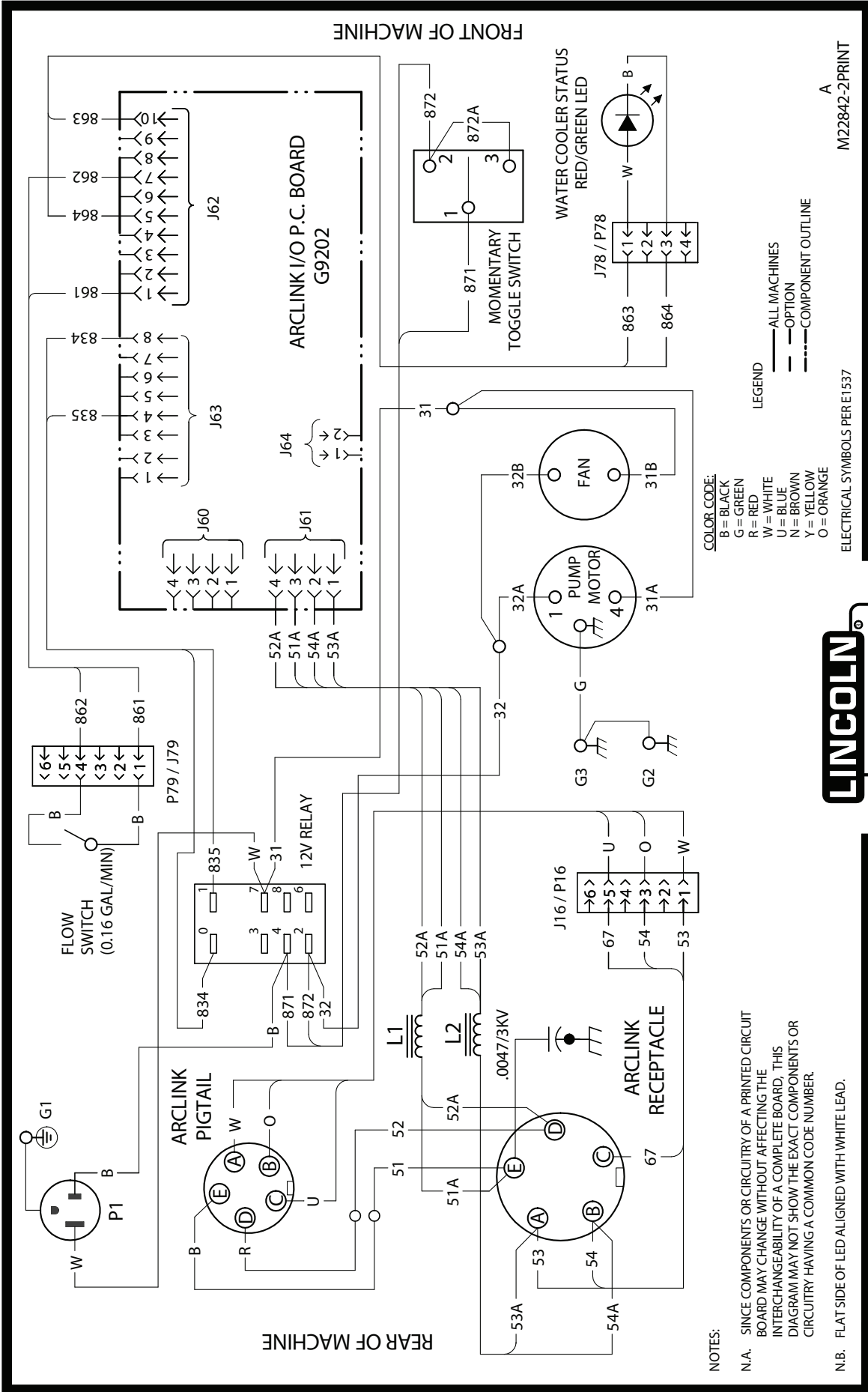

NOTES:

N.A. SINCE COMPONENTS OR CIRCUITRY OF A PRINTED CIRCUIT BOARD MAY CHANGE WITHOUT AFFECTING THE INTERCHANGEABILITY OF A COMPLETE BOARD, THIS DIAGRAM MAY NOT SHOW THE EXACT COMPONENTS OR CIRCUITRY HAVING A COMMON CODE NUMBER.

N.B. FLAT SIDE OF LED ALIGNED WITH WHITE LEAD.

**LINCOLN**  
**ELECTRIC**

CLEVELAND, OHIO U.S.A.

ELECTRICAL SYMBOLS PER E1537

A

M22842-2PRINT

NOTE: This diagram is for reference only. It may not be accurate for all machines covered by this manual. The specific diagram for a particular code is pasted inside the machine on one of the enclosure panels. If the diagram is illegible, write to the Service Department for a replacement. Give the equipment code number.

COOL ARC® 55 S

**LINCOLN**  
**ELECTRIC**

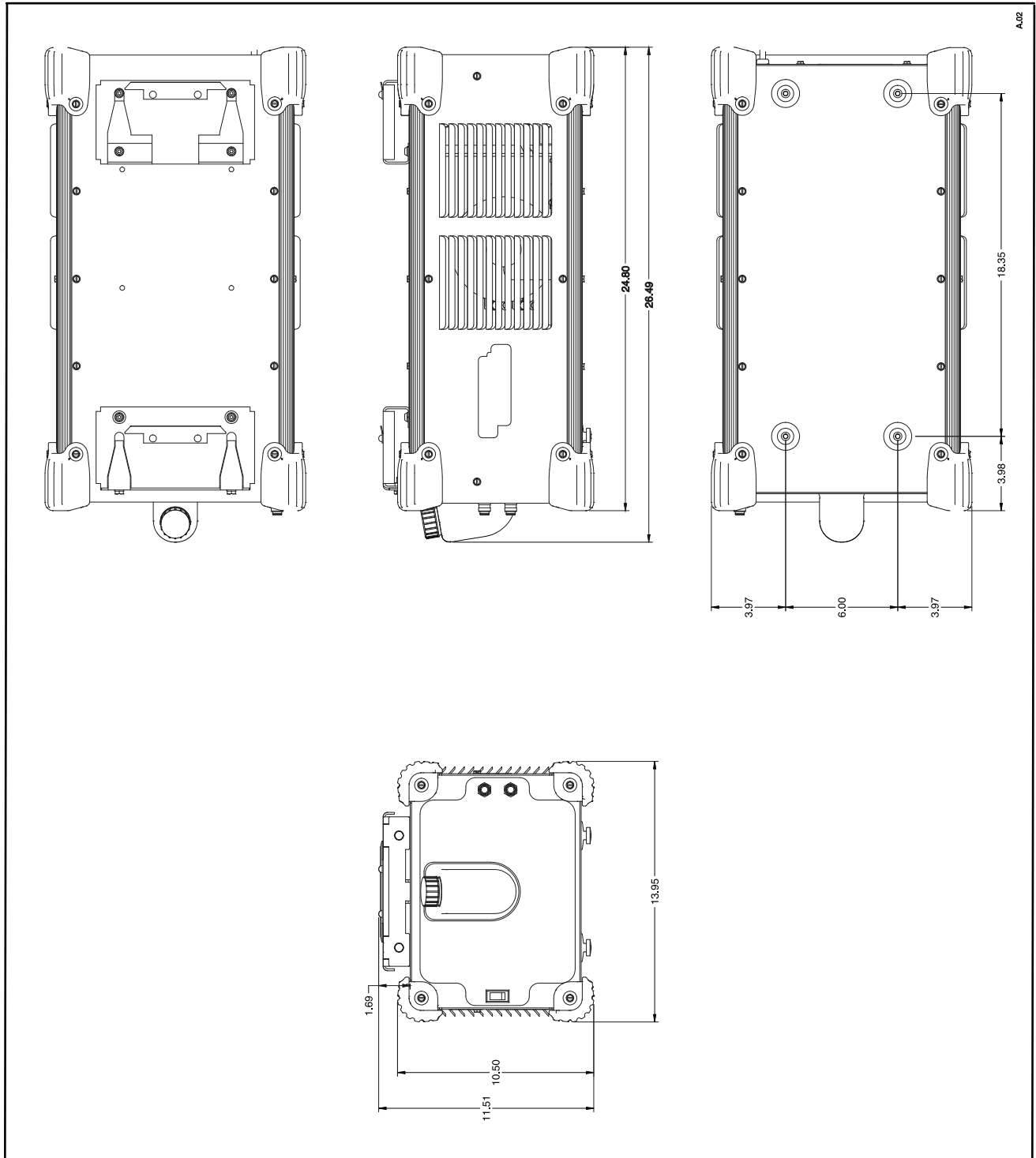

COOL ARC® 55 S











			
<b>WARNING</b>	<ul style="list-style-type: none"> <li>Do not touch electrically live parts or electrode with skin or wet clothing.</li> <li>Insulate yourself from work and ground.</li> </ul>	<ul style="list-style-type: none"> <li>Keep flammable materials away.</li> </ul>	<ul style="list-style-type: none"> <li>Wear eye, ear and body protection.</li> </ul>
Spanish <b>AVISO DE PRECAUCION</b>	<ul style="list-style-type: none"> <li>No toque las partes o los electrodos bajo carga con la piel o ropa mojada.</li> <li>Aíslese del trabajo y de la tierra.</li> </ul>	<ul style="list-style-type: none"> <li>Mantenga el material combustible fuera del área de trabajo.</li> </ul>	<ul style="list-style-type: none"> <li>Protéjase los ojos, los oídos y el cuerpo.</li> </ul>
French <b>ATTENTION</b>	<ul style="list-style-type: none"> <li>Ne laissez ni la peau ni des vêtements mouillés entrer en contact avec des pièces sous tension.</li> <li>Isolez-vous du travail et de la terre.</li> </ul>	<ul style="list-style-type: none"> <li>Gardez à l'écart de tout matériel inflammable.</li> </ul>	<ul style="list-style-type: none"> <li>Protégez vos yeux, vos oreilles et votre corps.</li> </ul>
German <b>WARNUNG</b>	<ul style="list-style-type: none"> <li>Berühren Sie keine stromführenden Teile oder Elektroden mit Ihrem Körper oder feuchter Kleidung!</li> <li>Isolieren Sie sich von den Elektroden und dem Erdboden!</li> </ul>	<ul style="list-style-type: none"> <li>Entfernen Sie brennbares Material!</li> </ul>	<ul style="list-style-type: none"> <li>Tragen Sie Augen-, Ohren- und Körperschutz!</li> </ul>
Portuguese <b>ATENÇÃO</b>	<ul style="list-style-type: none"> <li>Não toque partes elétricas e electrodos com a pele ou roupa molhada.</li> <li>Isole-se da peça e terra.</li> </ul>	<ul style="list-style-type: none"> <li>Mantenha inflamáveis bem guardados.</li> </ul>	<ul style="list-style-type: none"> <li>Use proteção para a vista, ouvido e corpo.</li> </ul>
Japanese <b>注意事項</b>	<ul style="list-style-type: none"> <li>通電中の電気部品、又は溶材にヒブやぬれた布で触れないこと。</li> <li>施工物やアースから身体が絶縁されている様にして下さい。</li> </ul>	<ul style="list-style-type: none"> <li>燃えやすいものの側での溶接作業は絶対にしてはなりません。</li> </ul>	<ul style="list-style-type: none"> <li>目、耳及び身体に保護具をして下さい。</li> </ul>
Chinese <b>警告</b>	<ul style="list-style-type: none"> <li>皮肤或湿衣物切勿接触带电部件及焊条。</li> <li>使你自已与地面和工作件绝缘。</li> </ul>	<ul style="list-style-type: none"> <li>把一切易燃物品移离工作场所。</li> </ul>	<ul style="list-style-type: none"> <li>佩戴眼、耳及身体劳动保护用具。</li> </ul>
Korean <b>위험</b>	<ul style="list-style-type: none"> <li>전도체나 용접봉을 젖은 헝겍 또는 피부로 절대 접촉치 마십시오.</li> <li>모재와 접지를 접촉치 마십시오.</li> </ul>	<ul style="list-style-type: none"> <li>인화성 물질을 접근시키지 마십시오.</li> </ul>	<ul style="list-style-type: none"> <li>눈, 귀와 몸에 보호장구를 착용하십시오.</li> </ul>
Arabic <b>تحذير</b>	<ul style="list-style-type: none"> <li>لا تلمس الاجزاء التي يسري فيها التيار الكهربائي أو الألكترود بجسدك أو بالملابس المبللة بالماء.</li> <li>ضع عازلا على جسمك خلال العمل.</li> </ul>	<ul style="list-style-type: none"> <li>ضع المواد القابلة للاشتعال في مكان بعيد.</li> </ul>	<ul style="list-style-type: none"> <li>ضع أدوات وملابس واقية على عينيك وأذنيك وجسمك.</li> </ul>

**READ AND UNDERSTAND THE MANUFACTURER'S INSTRUCTION FOR THIS EQUIPMENT AND THE CONSUMABLES TO BE USED AND FOLLOW YOUR EMPLOYER'S SAFETY PRACTICES.**

**SE RECOMIENDA LEER Y ENTENDER LAS INSTRUCCIONES DEL FABRICANTE PARA EL USO DE ESTE EQUIPO Y LOS CONSUMIBLES QUE VA A UTILIZAR, SIGA LAS MEDIDAS DE SEGURIDAD DE SU SUPERVISOR.**

**LISEZ ET COMPRENEZ LES INSTRUCTIONS DU FABRICANT EN CE QUI REGARDE CET EQUIPMENT ET LES PRODUITS A ETRE EMPLOYES ET SUIVEZ LES PROCEDURES DE SECURITE DE VOTRE EMPLOYEUR.**

**LESEN SIE UND BEFOLGEN SIE DIE BETRIEBSANLEITUNG DER ANLAGE UND DEN ELEKTRODENEINSATZ DES HERSTELLERS. DIE UNFALLVERHÜTUNGSVORSCHRIFTEN DES ARBEITGEBERS SIND EBENFALLS ZU BEACHTEN.**

			
<ul style="list-style-type: none"> <li>● Keep your head out of fumes.</li> <li>● Use ventilation or exhaust to remove fumes from breathing zone.</li> </ul>	<ul style="list-style-type: none"> <li>● Turn power off before servicing.</li> </ul>	<ul style="list-style-type: none"> <li>● Do not operate with panel open or guards off.</li> </ul>	<b>WARNING</b>
<ul style="list-style-type: none"> <li>● Los humos fuera de la zona de respiración.</li> <li>● Mantenga la cabeza fuera de los humos. Utilice ventilación o aspiración para gases.</li> </ul>	<ul style="list-style-type: none"> <li>● Desconectar el cable de alimentación de poder de la máquina antes de iniciar cualquier servicio.</li> </ul>	<ul style="list-style-type: none"> <li>● No operar con panel abierto o guardas quitadas.</li> </ul>	Spanish <b>AVISO DE PRECAUCION</b>
<ul style="list-style-type: none"> <li>● Gardez la tête à l'écart des fumées.</li> <li>● Utilisez un ventilateur ou un aspirateur pour ôter les fumées des zones de travail.</li> </ul>	<ul style="list-style-type: none"> <li>● Débranchez le courant avant l'entretien.</li> </ul>	<ul style="list-style-type: none"> <li>● N'opérez pas avec les panneaux ouverts ou avec les dispositifs de protection enlevés.</li> </ul>	French <b>ATTENTION</b>
<ul style="list-style-type: none"> <li>● Vermeiden Sie das Einatmen von Schweißrauch!</li> <li>● Sorgen Sie für gute Be- und Entlüftung des Arbeitsplatzes!</li> </ul>	<ul style="list-style-type: none"> <li>● Strom vor Wartungsarbeiten abschalten! (Netzstrom völlig öffnen; Maschine anhalten!)</li> </ul>	<ul style="list-style-type: none"> <li>● Anlage nie ohne Schutzgehäuse oder Innenschutzverkleidung in Betrieb setzen!</li> </ul>	German <b>WARNUNG</b>
<ul style="list-style-type: none"> <li>● Mantenha seu rosto da fumaça.</li> <li>● Use ventilação e exaustão para remover fumo da zona respiratória.</li> </ul>	<ul style="list-style-type: none"> <li>● Não opere com as tampas removidas.</li> <li>● Desligue a corrente antes de fazer serviço.</li> <li>● Não toque as partes elétricas nuas.</li> </ul>	<ul style="list-style-type: none"> <li>● Mantenha-se afastado das partes moventes.</li> <li>● Não opere com os painéis abertos ou guardas removidas.</li> </ul>	Portuguese <b>ATENÇÃO</b>
<ul style="list-style-type: none"> <li>● ヒュームから頭を離すようにして下さい。</li> <li>● 換気や排煙に十分留意して下さい。</li> </ul>	<ul style="list-style-type: none"> <li>● メンテナンス・サービスに取りかかる際には、まず電源スイッチを必ず切して下さい。</li> </ul>	<ul style="list-style-type: none"> <li>● パネルやカバーを取り外したまま機械操作をしないで下さい。</li> </ul>	Japanese <b>注意事項</b>
<ul style="list-style-type: none"> <li>● 頭部遠離煙霧。</li> <li>● 在呼吸區使用通風或排風器除煙。</li> </ul>	<ul style="list-style-type: none"> <li>● 維修前切斷電源。</li> </ul>	<ul style="list-style-type: none"> <li>● 儀表板打開或沒有安全罩時不準作業。</li> </ul>	Chinese <b>警告</b>
<ul style="list-style-type: none"> <li>● 얼굴로부터 용접가스를 멀리하십시오.</li> <li>● 호흡지역으로부터 용접가스를 제거하기 위해 가스제거기나 통풍기를 사용하십시오.</li> </ul>	<ul style="list-style-type: none"> <li>● 보수전에 전원을 차단하십시오.</li> </ul>	<ul style="list-style-type: none"> <li>● 판넬이 열린 상태로 작동치 마십시오.</li> </ul>	Korean <b>위험</b>
<ul style="list-style-type: none"> <li>● ابعد رأسك بعيداً عن الدخان.</li> <li>● استعمل التهوية أو جهاز ضغط الدخان للخارج لكي تبعد الدخان عن المنطقة التي تتنفس فيها.</li> </ul>	<ul style="list-style-type: none"> <li>● أقطع التيار الكهربائي قبل القيام بأية صيانة.</li> </ul>	<ul style="list-style-type: none"> <li>● لا تشغيل هذا الجهاز اذا كانت الاغطية الحديدية الواقية ليست عليه.</li> </ul>	Arabic <b>تحذير</b>

**LEIA E COMPREENDA AS INSTRUÇÕES DO FABRICANTE PARA ESTE EQUIPAMENTO E AS PARTES DE USO, E SIGA AS PRÁTICAS DE SEGURANÇA DO EMPREGADOR.**

使う機械や溶材のメーカーの指示書をよく読み、まず理解して下さい。そして貴社の安全規定に従って下さい。

請詳細閱讀並理解製造廠提供的說明以及應該使用的銀焊材料，並請遵守貴方的有關勞動保護規定。

이 제품에 동봉된 작업지침서를 숙지하시고 귀사의 작업자 안전수칙을 준수하시기 바랍니다.

اقرأ بتمعن وافهم تعليمات المصنع المنتج لهذه المعدات والمواد قبل استعمالها واتبع تعليمات الوقاية لصاحب العمل.

## **CUSTOMER ASSISTANCE POLICY**

The business of Lincoln Electric is manufacturing and selling high quality welding equipment, automated welding systems, consumables, and cutting equipment. Our challenge is to meet the needs of our customers, who are experts in their fields, and to exceed their expectations. On occasion, purchasers may ask Lincoln Electric for information or technical information about their use of our products. Our employees respond to inquiries to the best of their ability based on information and specifications provided to them by the customers and the knowledge they may have concerning the application. Our employees, however, are not in a position to verify the information provided or to evaluate the engineering requirements for the particular weldment, or to provide engineering advice in relation to a specific situation or application. Accordingly, Lincoln Electric does not warrant or guarantee or assume any liability with respect to such information or communications. Moreover, the provision of such information or technical information does not create, expand, or alter any warranty on our products. Any express or implied warranty that might arise from the information or technical information, including any implied warranty of merchantability or any warranty of fitness for any customers' particular purpose or any other equivalent or similar warranty is specifically disclaimed.

Lincoln Electric is a responsive manufacturer, but the definition of specifications, and the selection and use of specific products sold by Lincoln Electric is solely within the control of, and remains the sole responsibility of the customer. Many variables beyond the control of Lincoln Electric affect the results obtained in applying these types of fabrication methods and service requirements.

## **WELD FUME CONTROL EQUIPMENT**

The operation of welding fume control equipment is affected by various factors including proper use and positioning of the equipment, maintenance of the equipment and the specific welding procedure and application involved. Worker exposure level should be checked upon installation and periodically thereafter to be certain it is within applicable OSHA PEL and ACGIH TLV limits.



### **THE LINCOLN ELECTRIC COMPANY**

22801 St. Clair Avenue • Cleveland, OH • 44117-1199 • U.S.A.  
Phone: +1.216.481.8100 • [www.lincolnelectric.com](http://www.lincolnelectric.com)