



Operator's Manual

IDEALARC® AC/DC 250

For use with machines having Code Numbers:

- 9491; 9512; 9513; 9514; 9548; 9645;
- 9646; 9670; 9712; 9713; 9738; 9755;
- 9992; 9993; 9994; 9995; 9996; 9997;
- 9998; 11094; 11100; 11101; 11102;
- 11103; 11104

.....

PRODUCT REGISTRATION

.....



Registering your product only takes a few minutes, ensures your qualification for available warranties and allows you to receive updates and information on your product.

Follow the QR code below to register.



https://lred.info/product_registration-1



Register your machine:
<https://lred.info/locator>

Authorized Service and Distributor Locator:
www.lincolnelectric.com/locator

Save for future reference

THANK YOU FOR SELECTING A QUALITY PRODUCT BY LINCOLN ELECTRIC.

PLEASE EXAMINE CARTON AND EQUIPMENT FOR DAMAGE IMMEDIATELY

When this equipment is shipped, title passes to the purchaser upon receipt by the carrier. Consequently, claims for material damaged in shipment must be made by the purchaser against the transportation company at the time the shipment is received.

SAFETY DEPENDS ON YOU

Lincoln arc welding and cutting equipment is designed and built with safety in mind. However, your overall safety can be increased by proper installation ... and thoughtful operation on your part. **DO NOT INSTALL, OPERATE OR REPAIR THIS EQUIPMENT WITHOUT READING THIS MANUAL AND THE SAFETY PRECAUTIONS CONTAINED THROUGHOUT.** And, most importantly, think before you act and be careful.

WARNING

This statement appears where the information must be followed exactly to avoid serious personal injury or loss of life.

CAUTION

This statement appears where the information must be followed to avoid minor personal injury or damage to this equipment.



KEEP YOUR HEAD OUT OF THE FUMES.

DON'T get too close to the arc. Use corrective lenses if necessary to stay a reasonable distance away from the arc.

READ and obey the Safety Data Sheet (SDS) and the warning label that appears on all containers of welding materials.

USE ENOUGH VENTILATION or exhaust at the arc, or both, to keep the fumes and gases from your breathing zone and the general area.

IN A LARGE ROOM OR OUTDOORS, natural ventilation may be adequate if you keep your head out of the fumes (See below).

USE NATURAL DRAFTS or fans to keep the fumes away from your face.

If you develop unusual symptoms, see your supervisor. Perhaps the welding atmosphere and ventilation system should be checked.

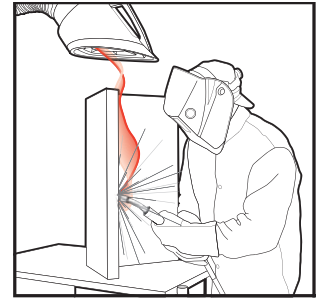

WEAR CORRECT EYE, EAR & BODY PROTECTION

PROTECT your eyes and face with welding helmet properly fitted and with proper grade of filter plate (See ANSI Z49.1).

PROTECT your body from welding spatter and arc flash with protective clothing including woolen clothing, flame-proof apron and gloves, leather leggings, and high boots.

PROTECT others from splatter, flash, and glare with protective screens or barriers.

IN SOME AREAS, protection from noise may be appropriate.

BE SURE protective equipment is in good condition.

Also, wear safety glasses in work area **AT ALL TIMES.**



SPECIAL SITUATIONS

DO NOT WELD OR CUT containers or materials which previously had been in contact with hazardous substances unless they are properly cleaned. This is extremely dangerous.

DO NOT WELD OR CUT painted or plated parts unless special precautions with ventilation have been taken. They can release highly toxic fumes or gases.

Additional precautionary measures

PROTECT compressed gas cylinders from excessive heat, mechanical shocks, and arcs; fasten cylinders so they cannot fall.

BE SURE cylinders are never grounded or part of an electrical circuit.

REMOVE all potential fire hazards from welding area.

ALWAYS HAVE FIRE FIGHTING EQUIPMENT READY FOR IMMEDIATE USE AND KNOW HOW TO USE IT.



SECTION A: WARNINGS



CALIFORNIA PROPOSITION 65 WARNINGS



WARNING: Breathing diesel engine exhaust exposes you to chemicals known to the State of California to cause cancer and birth defects, or other reproductive harm.

- Always start and operate the engine in a well-ventilated area.
- If in an exposed area, vent the exhaust to the outside.
- Do not modify or tamper with the exhaust system.
- Do not idle the engine except as necessary.

For more information go to www.P65warnings.ca.gov/diesel

WARNING: This product, when used for welding or cutting, produces fumes or gases which contain chemicals known to the State of California to cause birth defects and, in some cases, cancer. (California Health & Safety Code § 25249.5 *et seq.*)



WARNING: Cancer and Reproductive Harm
www.P65warnings.ca.gov

ARC WELDING CAN BE HAZARDOUS. PROTECT YOURSELF AND OTHERS FROM POSSIBLE SERIOUS INJURY OR DEATH. KEEP CHILDREN AWAY. PACEMAKER WEARERS SHOULD CONSULT WITH THEIR DOCTOR BEFORE OPERATING.

Read and understand the following safety highlights. For additional safety information, it is strongly recommended that you purchase a copy of "Safety in Welding & Cutting - ANSI Standard Z49.1" from the American Welding Society, P.O. Box 351040, Miami, Florida 33135 or CSA Standard W117.2. A Free copy of "Arc Welding Safety" booklet E205 is available from the Lincoln Electric Company, 22801 St. Clair Avenue, Cleveland, Ohio 44117-1199.

BE SURE THAT ALL INSTALLATION, OPERATION, MAINTENANCE AND REPAIR PROCEDURES ARE PERFORMED ONLY BY QUALIFIED INDIVIDUALS.



FOR ENGINE POWERED EQUIPMENT.

- Turn the engine off before troubleshooting and maintenance work unless the maintenance work requires it to be running.
- Operate engines in open, well-ventilated areas or vent the engine exhaust fumes outdoors.
- Do not add the fuel near an open flame welding arc or when the engine is running. Stop the engine and allow it to cool before refueling to prevent spilled fuel from vaporizing on contact



with hot engine parts and igniting. Do not spill fuel when filling tank. If fuel is spilled, wipe it up and do not start engine until fumes have been eliminated.

- Keep all equipment safety guards, covers and devices in position and in good repair. Keep hands, hair, clothing and tools away from V-belts, gears, fans and all other moving parts when starting, operating or repairing equipment.
- In some cases it may be necessary to remove safety guards to perform required maintenance. Remove guards only when necessary and replace them when the maintenance requiring their removal is complete. Always use the greatest care when working near moving parts.
- Do not put your hands near the engine fan. Do not attempt to override the governor or idler by pushing on the throttle control rods while the engine is running.
- To prevent accidentally starting gasoline engines while turning the engine or welding generator during maintenance work, disconnect the spark plug wires, distributor cap or magneto wire as appropriate.
- To avoid scalding, do not remove the radiator pressure cap when the engine is hot.
- Using a generator indoors CAN KILL YOU IN MINUTES.
- Generator exhaust contains carbon monoxide. This is a poison you cannot see or smell.
- NEVER use inside a home or garage, EVEN IF doors and windows are open.
- Only use OUTSIDE and far away from windows, doors and vents.
- Avoid other generator hazards. READ MANUAL BEFORE USE.



ELECTRIC AND MAGNETIC FIELDS MAY BE DANGEROUS



- Electric current flowing through any conductor causes localized Electric and Magnetic Fields (EMF). Welding current creates EMF fields around welding cables and welding machines
- EMF fields may interfere with some pacemakers, and welders having a pacemaker should consult their physician before welding.
- Exposure to EMF fields in welding may have other health effects which are now not known.
- All welders should use the following procedures in order to minimize exposure to EMF fields from the welding circuit:
 - Route the electrode and work cables together - Secure them with tape when possible.
 - Never coil the electrode lead around your body.
 - Do not place your body between the electrode and work cables. If the electrode cable is on your right side, the work cable should also be on your right side.
 - Connect the work cable to the workpiece as close as possible to the area being welded.
 - Do not work next to welding power source.



ELECTRIC SHOCK CAN KILL.



- 3.a. The electrode and work (or ground) circuits are electrically “hot” when the welder is on. Do not touch these “hot” parts with your bare skin or wet clothing. Wear dry, hole-free gloves to insulate hands.
- 3.b. Insulate yourself from work and ground using dry insulation. Make certain the insulation is large enough to cover your full area of physical contact with work and ground.

In addition to the normal safety precautions, if welding must be performed under electrically hazardous conditions (in damp locations or while wearing wet clothing; on metal structures such as floors, gratings or scaffolds; when in cramped positions such as sitting, kneeling or lying, if there is a high risk of unavoidable or accidental contact with the workpiece or ground) use the following equipment:

- Semiautomatic DC Constant Voltage (Wire) Welder.
 - DC Manual (Stick) Welder.
 - AC Welder with Reduced Voltage Control.
- 3.c. In semiautomatic or automatic wire welding, the electrode, electrode reel, welding head, nozzle or semiautomatic welding gun are also electrically “hot”.
 - 3.d. Always be sure the work cable makes a good electrical connection with the metal being welded. The connection should be as close as possible to the area being welded.
 - 3.e. Ground the work or metal to be welded to a good electrical (earth) ground.
 - 3.f. Maintain the electrode holder, work clamp, welding cable and welding machine in good, safe operating condition. Replace damaged insulation.
 - 3.g. Never dip the electrode in water for cooling.
 - 3.h. Never simultaneously touch electrically “hot” parts of electrode holders connected to two welders because voltage between the two can be the total of the open circuit voltage of both welders.
 - 3.i. When working above floor level, use a safety belt to protect yourself from a fall should you get a shock.
 - 3.j. Also see Items 6.c. and 8.



ARC RAYS CAN BURN.



- 4.a. Use a shield with the proper filter and cover plates to protect your eyes from sparks and the rays of the arc when welding or observing open arc welding. Headshield and filter lens should conform to ANSI Z87.1 standards.
- 4.b. Use suitable clothing made from durable flame-resistant material to protect your skin and that of your helpers from the arc rays.
- 4.c. Protect other nearby personnel with suitable, non-flammable screening and/or warn them not to watch the arc nor expose themselves to the arc rays or to hot spatter or metal.



FUMES AND GASES CAN BE DANGEROUS.



- 5.a. Welding may produce fumes and gases hazardous to health. Avoid breathing these fumes and gases. When welding, keep your head out of the fume. Use enough ventilation and/or exhaust at the arc to keep fumes and gases away from the breathing zone. **When welding hardfacing (see instructions on container or SDS) or on lead or cadmium plated steel and other metals or coatings which produce highly toxic fumes, keep exposure as low as possible and within applicable OSHA PEL and ACGIH TLV limits using local exhaust or mechanical ventilation unless exposure assessments indicate otherwise. In confined spaces or in some circumstances, outdoors, a respirator may also be required. Additional precautions are also required when welding on galvanized steel.**
- 5.b. The operation of welding fume control equipment is affected by various factors including proper use and positioning of the equipment, maintenance of the equipment and the specific welding procedure and application involved. Worker exposure level should be checked upon installation and periodically thereafter to be certain it is within applicable OSHA PEL and ACGIH TLV limits.
- 5.c. Do not weld in locations near chlorinated hydrocarbon vapors coming from degreasing, cleaning or spraying operations. The heat and rays of the arc can react with solvent vapors to form phosgene, a highly toxic gas, and other irritating products.
- 5.d. Shielding gases used for arc welding can displace air and cause injury or death. Always use enough ventilation, especially in confined areas, to insure breathing air is safe.
- 5.e. Read and understand the manufacturer’s instructions for this equipment and the consumables to be used, including the Safety Data Sheet (SDS) and follow your employer’s safety practices. SDS forms are available from your welding distributor or from the manufacturer.
- 5.f. Also see item 1.b.



WELDING AND CUTTING SPARKS CAN CAUSE FIRE OR EXPLOSION.

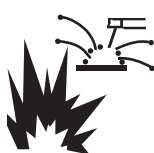

- 6.a. Remove fire hazards from the welding area. If this is not possible, cover them to prevent the welding sparks from starting a fire. Remember that welding sparks and hot materials from welding can easily go through small cracks and openings to adjacent areas. Avoid welding near hydraulic lines. Have a fire extinguisher readily available.
- 6.b. Where compressed gases are to be used at the job site, special precautions should be used to prevent hazardous situations. Refer to "Safety in Welding and Cutting" (ANSI Standard Z49.1) and the operating information for the equipment being used.
- 6.c. When not welding, make certain no part of the electrode circuit is touching the work or ground. Accidental contact can cause overheating and create a fire hazard.
- 6.d. Do not heat, cut or weld tanks, drums or containers until the proper steps have been taken to insure that such procedures will not cause flammable or toxic vapors from substances inside. They can cause an explosion even though they have been "cleaned". For information, purchase "Recommended Safe Practices for the Preparation for Welding and Cutting of Containers and Piping That Have Held Hazardous Substances", AWS F4.1 from the American Welding Society (see address above).
- 6.e. Vent hollow castings or containers before heating, cutting or welding. They may explode.
- 6.f. Sparks and spatter are thrown from the welding arc. Wear oil free protective garments such as leather gloves, heavy shirt, cuffless trousers, high shoes and a cap over your hair. Wear ear plugs when welding out of position or in confined places. Always wear safety glasses with side shields when in a welding area.
- 6.g. Connect the work cable to the work as close to the welding area as practical. Work cables connected to the building framework or other locations away from the welding area increase the possibility of the welding current passing through lifting chains, crane cables or other alternate circuits. This can create fire hazards or overheat lifting chains or cables until they fail.
- 6.h. Also see item 1.c.
- 6.i. Read and follow NFPA 51B "Standard for Fire Prevention During Welding, Cutting and Other Hot Work", available from NFPA, 1 Batterymarch Park, PO box 9101, Quincy, MA 022690-9101.
- 6.j. Do not use a welding power source for pipe thawing.



CYLINDER MAY EXPLODE IF DAMAGED.

- 7.a. Use only compressed gas cylinders containing the correct shielding gas for the process used and properly operating regulators designed for the gas and pressure used. All hoses, fittings, etc. should be suitable for the application and maintained in good condition. 
- 7.b. Always keep cylinders in an upright position securely chained to an undercarriage or fixed support.
- 7.c. Cylinders should be located:
 - Away from areas where they may be struck or subjected to physical damage.
 - A safe distance from arc welding or cutting operations and any other source of heat, sparks, or flame.
- 7.d. Never allow the electrode, electrode holder or any other electrically "hot" parts to touch a cylinder.
- 7.e. Keep your head and face away from the cylinder valve outlet when opening the cylinder valve.
- 7.f. Valve protection caps should always be in place and hand tight except when the cylinder is in use or connected for use.
- 7.g. Read and follow the instructions on compressed gas cylinders, associated equipment, and CGA publication P-1, "Precautions for Safe Handling of Compressed Gases in Cylinders," available from the Compressed Gas Association, 14501 George Carter Way Chantilly, VA 20151.



FOR ELECTRICALLY POWERED EQUIPMENT.



- 8.a. Turn off input power using the disconnect switch at the fuse box before working on the equipment.
- 8.b. Install equipment in accordance with the U.S. National Electrical Code, all local codes and the manufacturer's recommendations.
- 8.c. Ground the equipment in accordance with the U.S. National Electrical Code and the manufacturer's recommendations.

Refer to
<http://www.lincolnelectric.com/safety>
for additional safety information.

Thank You

for selecting a **QUALITY** product by Lincoln Electric. We want you to take pride in operating this Lincoln Electric Company product
 ... as much pride as we have in bringing this product to you!

CUSTOMER ASSISTANCE POLICY

The business of The Lincoln Electric Company is manufacturing and selling high quality welding equipment, consumables, and cutting equipment. Our challenge is to meet the needs of our customers and to exceed their expectations. On occasion, purchasers may ask Lincoln Electric for advice or information about their use of our products. We respond to our customers based on the best information in our possession at that time. Lincoln Electric is not in a position to warrant or guarantee such advice, and assumes no liability, with respect to such information or advice. We expressly disclaim any warranty of any kind, including any warranty of fitness for any customer's particular purpose, with respect to such information or advice. As a matter of practical consideration, we also cannot assume any responsibility for updating or correcting any such information or advice once it has been given, nor does the provision of information or advice create, expand or alter any warranty with respect to the sale of our products.

Lincoln Electric is a responsive manufacturer, but the selection and use of specific products sold by Lincoln Electric is solely within the control of, and remains the sole responsibility of the customer. Many variables beyond the control of Lincoln Electric affect the results obtained in applying these types of fabrication methods and service requirements.

Subject to Change – This information is accurate to the best of our knowledge at the time of printing. Please refer to www.lincolnelectric.com for any updated information.

Please Examine Carton and Equipment For Damage Immediately

When this equipment is shipped, title passes to the purchaser upon receipt by the carrier. Consequently, Claims for material damaged in shipment must be made by the purchaser against the transportation company at the time the shipment is received.

Please record your equipment identification information below for future reference. This information can be found on your machine nameplate.

Product _____

Model Number _____

Code Number or Date Code _____

Serial Number _____

Date Purchased _____

Where Purchased _____

Whenever you request replacement parts or information on this equipment, always supply the information you have recorded above. The code number is especially important when identifying the correct replacement parts.

On-Line Product Registration

- Register your machine with Lincoln Electric either via fax or over the Internet.
 - For faxing: Complete the form on the back of the warranty statement included in the literature packet accompanying this machine and fax the form per the instructions printed on it.
 - For On-Line Registration: Go to our **WEB SITE at www.lincolnelectric.com**. Choose "Quick Links" and then "Product Registration". Please complete the form and submit your registration.

Read this Operators Manual completely before attempting to use this equipment. Save this manual and keep it handy for quick reference. Pay particular attention to the safety instructions we have provided for your protection. The level of seriousness to be applied to each is explained below:

⚠ WARNING

This statement appears where the information **must** be followed **exactly** to avoid **serious personal injury** or **loss of life**.

⚠ CAUTION

This statement appears where the information **must** be followed to avoid **minor personal injury** or **damage to this equipment**.

TABLE OF CONTENTS

	Page
GENERAL DESCRIPTION	8
<hr/>	
RECOMMENDED PROCESSES & EQUIPMENT	8
AC and DC Constant Current Welding	8
TIG Welding	8
<hr/>	
DESIGN FEATURES	8
<hr/>	
OPTIONS/ACCESSORIES & COMPATIBLE LINCOLN EQUIPMENT	8
Power Factor Capacitors	8
Undercarriage	8
Hi-Freq	8
Standard Accessory Set	8
<hr/>	
TECHNICAL SPECIFICATIONS	9
<hr/>	
INSTALLATION	10-11
Safety Precautions	10
Machine Installation	10
Location	10
Input Connections	10
Stacking	11
Installation of Field Installed Options	11
Output Cable Size and Connection	11
<hr/>	
OPERATION	12
Safety Precautions	12
Duty Cycle	12
Control Operation	12
<hr/>	
MAINTENANCE	13
Safety Precautions	13
General Maintenance	13
<hr/>	
TROUBLESHOOTING	13-15
Rectifier Troubleshooting	13
Troubleshooting Procedures	14-15
<hr/>	
WIRING DIAGRAMS	16-17
<hr/>	
PARTS LIST	P200 Series

GENERAL DESCRIPTION

The Idealarc® 250 is a single phase constant current arc welding power source available in an AC/DC model only. Designed for stick welding, it may also be used for TIG welding when used with the K799 Hi-Freq unit.

RECOMMENDED PROCESSES AND EQUIPMENT

AC and DC Constant Current Welding

AC	35-300 Amps 60 Hz	35-250 Amps 50 Hz
DC	40-250 Amps 50/60 Hz	
Duty Cycle	60 Hz	
	100%-140 Amps	100%-140 Amps
	50%-200 Amps	60%-180 Amps
	30%-250 Amps	30%-250 Amps
Duty Cycle	50 Hz	
	20%-300 Amps	

TIG Welding

The K799 can be used with this machine to provide high frequency stabilization and a gas valve for TIG welding. It operates on 115V 50/60 Hz power. A water valve (for water cooled TIG torches) is available as an option.

When TIG welding, AC or DC may be used but when AC TIG welding, the duty cycle must be decreased by one-half.

DESIGN FEATURES

- Power On/Off switch.
- Polarity switch selects AC, DC+ or DC- .
- Continuous current control dials with exact welding current needed for each job. Settings are precise and free from creep.
- Spring loaded knob on the continuous current control crank pulls out for easy adjustment and snaps back out of the way when released.
- Meets NEMA Class II specifications.

- Recessed front panel protects controls.
- Large safety margins and protective circuits protect rectifiers from transient voltages and high currents.
- Submersion dipping of assembled transformer and choke in special sealing/insulating material gives extra protection against moisture and corrosive atmosphere.
- Stackability - Machines can be stacked up to three high.
- Outstanding Arc Stability - Transformer design and built-in stabilizer provide pop-out-resistant welding with all electrodes, including those which normally require an industrial type AC welder.
- Reconnect panel is provided to permit changing from one input voltage to another without reconnecting transformer leads.

OPTIONS / ACCESSORIES AND COMPATIBLE LINCOLN EQUIPMENT

Factory Installed Options/Accessories

- Power Factor Capacitors
(Reduce input amps by 30% at rated load.)

Field Installed Options

- Power Factor Capacitors
(Reduce input amps by 30% at rated load.)
- Undercarriage (K866)
Consists of a handle, axle, wheels, front bracket and mounting hardware. Overall width 24.56 inches (624 mm).
- Hi Freq Kit (K799)
Converts Idealarc 250 into a TIG welder. Request Bulletin E385 for full details.
- Standard Accessory Kit (K710)
Includes electrode holder, work clamp, electrode, work cables, and headshield with lens and coverplate

TECHNICAL SPECIFICATIONS: IDEALARC AC/DC 250

INPUT - OUTPUT RATINGS				
Model	AC/DC 250		AC/DC 250	
Type	K1053		K1054	
AC Input Frequency	60		50	
Output Rating	NEMA CLASS II (60)		IEC 974	
	AC	DC	AC	DC
Amperes	300	250	250	250
Volts	32	30	30	30
Duty Cycle	20	30	30	30
Current Range	35-300	40-250	35-250	40-250
Max. O.C.V.	72	70	72	70
Input Power				
Standard Voltages	208/230/460 230/460/575		220/380/440 380/415/500	
Rated Input Current (230V 60Hz, 220V 50Hz)				
With Condensers	68		68	
Without Condensers	86		86	
Idle Input Current (230V)				
With Condensers	23		23	
Without Condensers	6.2		6.2	
Power Factor (200 Amp Load)				
With Condensers	83.3		83.3	
Without Condensers	69.0		69.0	
PHYSICAL DIMENSIONS				
HEIGHT	WIDTH		DEPTH	WEIGHT
27.00 in.	19.00 in.		21.50 in.	350 lbs. 159 kg
686 mm	483 mm		546 mm	

INSTALLATION

Safety Precautions

WARNING



ELECTRIC SHOCK can kill.

- Do not touch electrically live parts or electrode with skin or wet clothing.
- Insulate yourself from work and ground.
- Always wear dry insulating gloves.



FUMES AND GASES can be dangerous.

- Keep your head out of fumes.
- Use ventilation or exhaust to remove fumes from breathing zone.



WELDING SPARKS can cause fire or explosion.

- Keep flammable material away.
- Do not weld on closed containers.



ARC RAYS can burn eyes and skin.

- Wear eye, ear and body protection.

See additional warning information at the front of this operator's manual.

- Connect the Idealarc 250 grounding terminal located under the reconnect panel (marked ) to a good electrical ground per the U.S. National Electrical Code and any applicable local codes.
- Turn the power switch on the Idealarc 250 "OFF" before connecting or disconnecting output cables or other equipment.
- Only qualified personnel should perform this installation.

Undercarriages: If the optional K866 undercarriage is to be installed, it should be done before connecting the welder to power lines. Instructions are included with the undercarriage.

Location

The machine should be located in a clean, dry place where there is free circulation of clean air such that air movement in the back and along the sides will not be restricted. Dirt and dust that can be drawn into the machine should be kept to a minimum. Failure to observe the precautions can result in excessive operating temperatures and nuisance shutdown of the machine.

Input Connections

Be sure the voltage, phase and frequency of the input power is as specified on the welder rating plate located on the rear panel of the machine. Either a single phase or one phase of a three phase line can be used.

Have a qualified electrician install the machine per the following instructions:

Remove the left side panel (viewed from the front). Route the input power lines through the hole in the rear panel and center baffle. Lug the input leads with a ring terminal for a 1/4" (6mm) screw. Connect lugged leads to L1 and L2 of the reconnect panel per the wiring diagram pasted to the inside of the side panel. Input connection must conform to the U.S. National Electrical Code and all local codes.

Models designed for two or three input voltages are shipped connected for the highest voltage. Reconnect instructions are on the diagram pasted to the inside of the side panel. Consult rating plate on the rear panel for machine input voltage rating.

The welder frame must be grounded. A stud marked with the symbol  located under the reconnect panel is provided for this purpose. See the U.S. National Electrical Code for details on proper grounding methods.

Fuse the input circuit with the recommended super lag fuses. Choose an input and grounding wire size according to local codes or use the following table. "Delay type" circuit breakers may be used in place of fuses. Using fuses or circuit breakers smaller than recommended may result in "nuisance" tripping from welder inrush currents even if not welding at high currents.

RECOMMENDED INPUT WIRE, GROUND WIRE AND FUSE SIZES 200 Amp Output and 50% Duty Cycle

		Input Amps		Copper Wire Sizes 75°C in Conduit			Fuse Size (Super Lag)	
Input Volts	Freq.	With P.F. Cap	Without P.F. Cap	With Cap	Without Cap	Grounding Conductor	With P.F. Cap	Without P.F. Cap
200	50/60	58	81	#8	#6	#8	70	100
208	60	55	77	#8	#6	#8	70	100
220/230	50/60	50	70	#8	#6	#8	70	90
380	50	29	41	#10	#8	#10	40	50
400	50/60	29	40	#10	#8	#10	40	50
440/460	50/60	25	35	#12	#10	#10	35	45
500	50	22	31	#14	#12	#10	30	40
575	60	20	28	#14	#12	#10	25	40

STACKING

WARNING



FALLING EQUIPMENT can cause injury.

- Do not lift this machine using lift bale if it is equipped with a heavy accessory such as undercarriage or gas cylinder.
- Lift only with equipment of adequate lifting capacity.
- Be sure machine is stable when lifting.
- Do not stack more than three high.
- Do not stack on top of any other type machine.

- A. Make sure the first or bottom unit is setting on a level, well supported surface.
- B. The units must be stacked with their front flush, making sure the two holes in the base rails of the unit being stacked on top are over the two holes located on the top front corners of the unit being stacked on. Fasten the units together with 5/16 (8 mm) bolts, nuts and lockwashers through these holes.
- C. Remote fastening bolts before lifting unit off stacks.

Installation of Field Installed Options

For installation of compatible field installed options, see Field Installed Options section, and refer to the instructions included with those options.

Output Cable Size and Connection

WARNING



ELECTRIC SHOCK can kill.

- Turn the power switch of the welding power source “**OFF**” before connecting or disconnecting output cables.

The output leads are connected to the output terminals marked “WORK” and “ELECTRODE”. They are located at the lower right and lower left corners of the front panel. The 60 Hz Idealarc 250 provides 1/2” studs for weld cable connections. The 50 Hz Idealarc 250 provides European weld cable connector receptacles. Minimum cable sizes recommended are listed in the table below.

CABLE SIZES FOR COMBINED LENGTHS OF COPPER ELECTRODE AND WORK CABLES

	200 Amps 50% Duty Cycle	250 Amps 30% Duty Cycle
0-100 Ft.	3 (30mm ²)	3 (30mm ²)
100-150 Ft.	2 (35mm ²)	2 (35mm ²)
150-200 Ft.	1 (45mm ²)	1 (45mm ²)
200-250 Ft.	1/0 (55mm ²)	1/0 (55mm ²)

OPERATION

Safety Precautions

WARNING



ELECTRIC SHOCK can kill.

- Do not touch electrically live parts or electrode with skin or wet clothing.
- Insulate yourself from work and ground.
- Always wear dry insulating gloves.



FUMES AND GASES can be dangerous.

- Keep your head out of fumes.
- Use ventilation or exhaust to remove fumes from breathing zone.

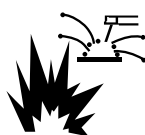

WELDING SPARKS can cause fire or explosion.

- Keep flammable material away.
- Do not weld on closed containers.



ARC RAYS can burn eyes and skin.

- Wear eye, ear and body protection.

See additional warning information at the front of this operator's manual.

Be sure the Idealarc 250 is properly installed, and that all accessories are properly hooked up before attempting operation.

DUTY CYCLE

This machine is rated at a 30% duty cycle at 250 amps or 50% duty cycle at 200 amp output. Duty cycle is based on a 10 minute period. Therefore, the welder can be loaded at 200 amperes for 5 minutes out of each 10 minute period. Higher duty cycles can be used at lower currents; see rating plate information.

CONTROL OPERATION

A. Current Control Handle

Rotating the hand wheel raises and lowers the output current allowing the operator to dial the desired current. Clockwise rotation reduces the current while counter-clockwise rotation increases the current. Turning the current control handle also drives the output pointer at the bottom of the nameplate which indicates the stick welding current at NEMA arc volts.

B. Polarity Switch

Turn the arc polarity switch in the upper right hand corner of the case front to AC, DC(-) or DC(+) as required for the particular application. **DO NOT CHANGE POLARITY SWITCH WHILE WELDING.** Doing this can seriously damage the switch.

C. TIG Welding

The Idealarc 250 with the optional Hi-Freq is an inexpensive equipment combination for part-time production or repair TIG welding of aluminum, magnesium, thin stainless steel and many space-age metals. The Idealarc 250 can be used for normal stick electrode welding with the Hi-Freq attached.

CAUTION

Reduce the Idealarc 250 duty cycle by 50% when AC TIG welding, i.e., the welder should be operated for only two and one half minutes out of every ten at rated current of 200 amperes.

The Hi-Freq includes high frequency generator, gas valve and needed controls. It operates on 115V, 50/60 Hz AC power.

NOTE: The Hi-Freq unit includes an R.F. bypass capacitor kit for power source protection. Installation instructions are in the kit. (When using the Idealarc 250 with any other high frequency equipment, an R.F. bypass capacitor must be installed. Order Kit T12246.) To provide protection, the welder grounding stud or frame must be connected to ground (see instructions on grounding in Machine Installation section). Also follow the grounding instructions given in the Hi-Freq Instruction manual.

MAINTENANCE

Safety Precautions

WARNING



ELECTRIC SHOCK can kill.

- Have a qualified individual install and service this equipment.
 - Turn the input power off at the fuse box before working on equipment.
 - Do not touch electrically hot parts.
-

General Maintenance

1. The fan motor has sealed ball bearings which requires no service.
2. In dusty locations dirt may clog the air channels causing the welder to run hot. Under these conditions carefully blow out the welder at regular intervals.
3. Keep the electrode and work cable connection tight.
4. Every twelve months or at the first indication of a binding current pointer, turn the input power off and remove the left case side. Wipe the pointer guide bar clean and lubricate with graphite grease.
5. When cleaning the current pointer, clean the reactor quadrant teeth, drive gear and pinion. Lubricate with graphite grease.

TROUBLESHOOTING

Safety Precautions

WARNING



ELECTRIC SHOCK can kill.

- Have a qualified individual install and service this equipment.
 - Turn the input power off at the fuse box before working on equipment.
 - Do not touch electrically hot parts.
-

Rectifier Troubleshooting

1. Turn the input power off.
2. Disconnect all input and output leads from the rectifier bridge.
3. Connect an ohmmeter between the DC positive (red) terminal and one of the AC (yellow) terminals. Note the ohmmeter reading using the 10 to 100 scale.
4. Reverse the ohmmeter leads. Note the readings.
5. The reading taken in steps 3 and 4 should be different. If the readings are the same and near zero, the rectifier has shorted. IF the readings are the same and near full scale, the rectifier has failed open.
6. Repeat steps 3, 4 and 5 between the DC positive (red) terminal and each of the AC (yellow) terminals.
7. Repeat steps 3, 4 and 5 between the DC negative (black) terminal and each of the AC (yellow) terminals.

NOTE: Since it is unlikely that all rectifiers of a full wave bridge would fail simultaneously, check the test method and the ohmmeter if the checking indicates that all rectifiers have failed.

TROUBLESHOOTING

TROUBLE	CAUSE	WHAT TO DO
<p>A. Welder will not weld.</p>	<ol style="list-style-type: none"> 1. Line switch not turned "On". Supply line fuse blown. 2. Power circuit dead. 3. Broken power lead. 4. Wrong voltage. 5. Electrode or work lead loose or broken. 6. Open transformer circuit. 7. Polarity switch not centered. 	<ol style="list-style-type: none"> 1. Place line switch in "On" position. Replace. (Look for reason for blown fuse first). 2. Check supply line voltage. 3. Repair. 4. Check voltage against rating plate. Check reconnect panel jumper. 5. Tighten and repair connections. 6. Send to repair shop to have coils replaced. 7. Center switch handle on DC(+), DC(-), or AC.
<p>B. Welder welds, but soon stops welding (DC only).</p>	<ol style="list-style-type: none"> 1. Proper ventilation hindered. 2. Welder loaded beyond rating. 3. Fan motor inoperative. 4. Poor internal connections. 5. Excessive dust accumulation in welder. 6. Bi-metallic thermostat dirty. 	<ol style="list-style-type: none"> 1. Make sure all case openings are free for proper circulation of air. 2. Operate at normal current and duty cycle consistent with rating. 3. Check leads and motor bearings. Fan motor can be tested on 115V line; with welder on, voltage across fan motor should be approximately 115V. 4. Check for loose or hot connections and tighten. 5. Blow out welder with low pressure. 6. Carefully clean in naphtha.

TROUBLESHOOTING (CONTINUED)

TROUBLE	CAUSE	WHAT TO DO
C. Variable or sluggish welding.	<ol style="list-style-type: none">1. Poor work or electrode terminal connection.2. Current too low.3. Low line voltage.4. Welding leads too small.5. Old and badly frayed welding cables.	<ol style="list-style-type: none">1. Check and clean all connections.2. Check recommended currents for rod type and size.3. Check with power company.4. See Output Cable section.5. Replace.
D. Welder won't shut off.	<ol style="list-style-type: none">1. Line switch has failed mechanically.	<ol style="list-style-type: none">1. Replace switch.
E. Polarity switch won't turn.	<ol style="list-style-type: none">1. Contacts rough and pitted from improper switching under load.	<ol style="list-style-type: none">1. Replace switch.

WIRING DIAGRAM - 250 AMP IDEALARC 60 HZ & 50 / 60 HZ



- WARNING**
- TURN THE INPUT POWER TO THE WELDER OFF USING THE DISCONNECT SWITCH AT THE FUSE BOX BEFORE INSTALLING OR SERVICING THIS MACHINE.
 - DO NOT TOUCH ELECTRICALLY "HOT" PARTS SUCH AS OUTPUT TERMINALS OR INTERNAL WINDINGS.
 - GROUNDING SCREW (⚡) MUST BE CONNECTED TO A GOOD EARTH GROUND THROUGH THE INPUT CABLE PER NATIONAL ELECTRICAL CODE
 - DO NOT OPERATE WITH COVERS REMOVED
 - ONLY QUALIFIED PERSONNEL SHOULD INSTALL OR SERVICE THIS EQUIPMENT.

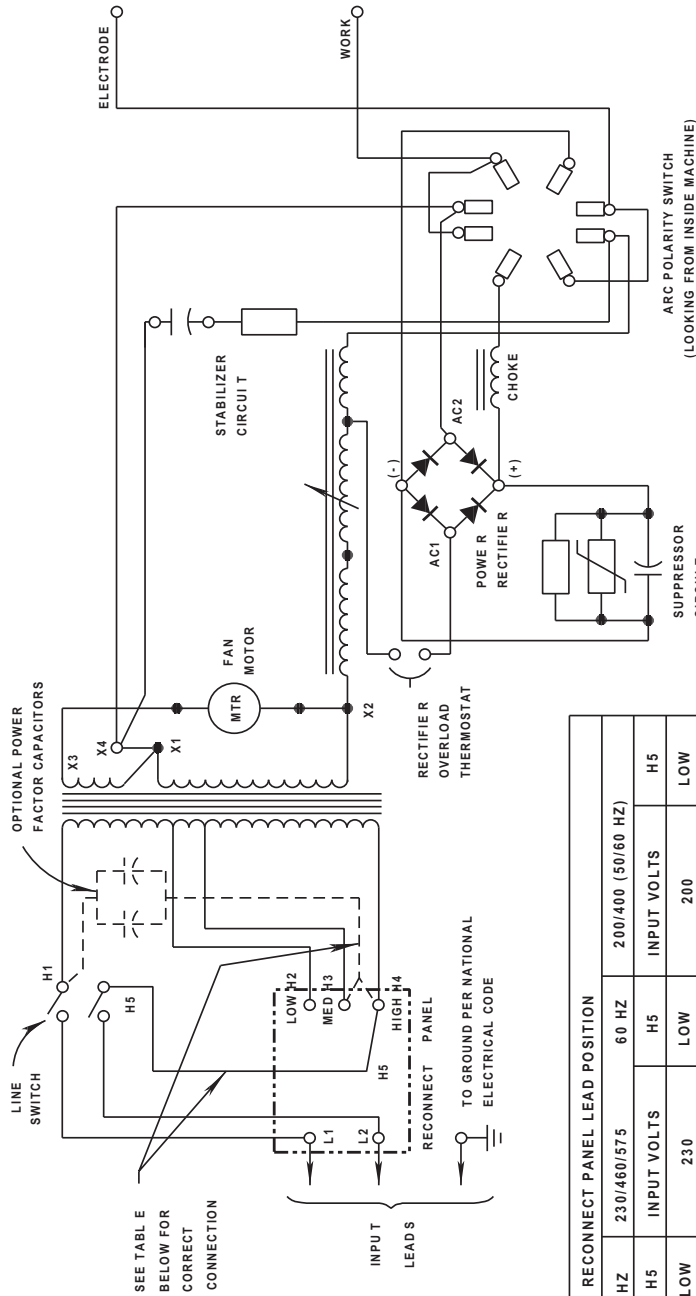

RECONNECT PANEL LEAD POSITION		60 HZ		200/400 (50/60 HZ)	
208/230/460	60 HZ	230/460/575	H5	INPUT VOLTS	H5
208	LOW	230	LOW	200	LOW
230	MED	460	MED	—	MED
460	HIGH	575	HIGH	400	HIGH
P.F. CAP LEAD -HIGH			P.F. CAP LEAD -MED		P.F. CAP LEAD -HIGH

CONNECTIONS MUST BE TIGHTENED SECURELY.
ELECTRICAL SYMBOLS PER E1537.

MACHINES ARE SHIPPED FROM FACTORY CONNECTED FOR HIGHEST INPUT VOLTAGE.

8-2-80

S19343

NOTE: This diagram is for reference only. It may not be accurate for all machines covered by this manual. The specific diagram for a particular code is pasted inside the machine on one of the enclosure panels. If the diagram is illegible, write to the Service Department for a replacement. Give the equipment code number..

WIRING DIAGRAM - 250 AMP IDEALARC 50 HZ



- WARNING**
- TURN THE INPUT POWER TO THE WELDER OFF USING THE DISCONNECT SWITCH AT THE FUSE BOX BEFORE INSTALLING OR SERVICING THIS MACHINE.
 - DO NOT TOUCH ELECTRICALLY "HOT" PARTS SUCH AS OUTPUT TERMINALS OR INTERNAL WINDINGS.
 - GROUNDING SCREW MUST BE CONNECTED TO A GOOD EARTH GROUND THROUGH THE INPUT CABLE PER NATIONAL ELECTRICAL CODE
 - DO NOT OPERATE WITH COVERS REMOVED
 - ONLY QUALIFIED PERSONNEL SHOULD INSTALL OR SERVICE THIS EQUIPMENT.

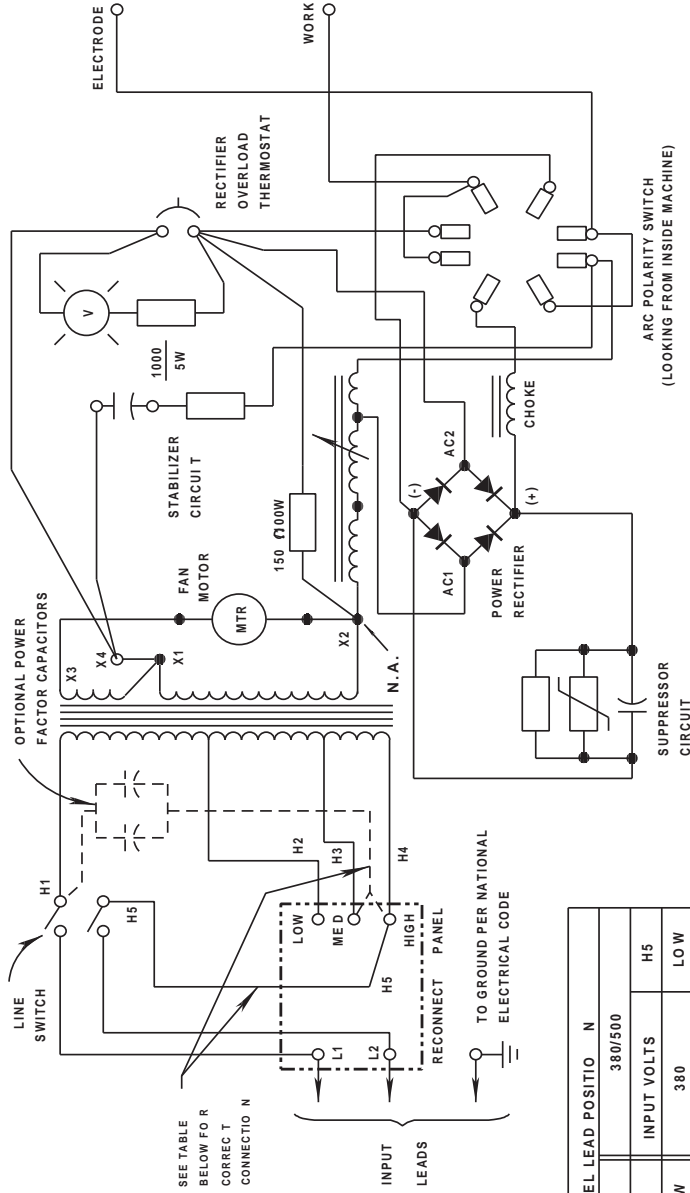

N.A. BOLTED CONNECTION ON MACHINES WITH COPPER COILS.

CONNECTIONS MUST BE TIGHTENED SECURELY.
ELECTRICAL SYMBOLS PER E1537.

RECONNECT PANEL LEAD POSITIO	N
220/380/440	380/500
INPUT VOLTS	H5
220	LOW
380	MED
440	HIGH
P.F. CAP LEAD -HIG	H D
	P.F. CAP LEAD -ME

MACHINES ARE SHIPPED FROM FACTORY CONNECTED FOR HIGHEST INPUT VOLTAGE.

NOTE: This diagram is for reference only. It may not be accurate for all machines covered by this manual. The specific diagram for a particular code is pasted inside the machine on one of the enclosure panels. If the diagram is illegible, write to the Service Department for a replacement. Give the equipment code number.

NOTES

WARNING	<ul style="list-style-type: none"> ● Do not touch electrically live parts or electrode with skin or wet clothing. ● Insulate yourself from work and ground. 	<ul style="list-style-type: none"> ● Keep flammable materials away. 	<ul style="list-style-type: none"> ● Wear eye, ear and body protection.
Spanish AVISO DE PRECAUCION	<ul style="list-style-type: none"> ● No toque las partes o los electrodos bajo carga con la piel o ropa mojada. ● Aíslese del trabajo y de la tierra. 	<ul style="list-style-type: none"> ● Mantenga el material combustible fuera del área de trabajo. 	<ul style="list-style-type: none"> ● Protéjase los ojos, los oídos y el cuerpo.
French ATTENTION	<ul style="list-style-type: none"> ● Ne laissez ni la peau ni des vêtements mouillés entrer en contact avec des pièces sous tension. ● Isolez-vous du travail et de la terre. 	<ul style="list-style-type: none"> ● Gardez à l'écart de tout matériel inflammable. 	<ul style="list-style-type: none"> ● Protégez vos yeux, vos oreilles et votre corps.
German WARNUNG	<ul style="list-style-type: none"> ● Berühren Sie keine stromführenden Teile oder Elektroden mit Ihrem Körper oder feuchter Kleidung! ● Isolieren Sie sich von den Elektroden und dem Erdboden! 	<ul style="list-style-type: none"> ● Entfernen Sie brennbares Material! 	<ul style="list-style-type: none"> ● Tragen Sie Augen-, Ohren- und Körperschutz!
Portuguese ATENÇÃO	<ul style="list-style-type: none"> ● Não toque partes elétricas e electrodos com a pele ou roupa molhada. ● Isole-se da peça e terra. 	<ul style="list-style-type: none"> ● Mantenha inflamáveis bem guardados. 	<ul style="list-style-type: none"> ● Use proteção para a vista, ouvido e corpo.
Japanese 注意事項	<ul style="list-style-type: none"> ● 通電中の電気部品、又は溶材にヒフやぬれた布で触れないこと。 ● 施工物やアースから身体が絶縁されている様にして下さい。 	<ul style="list-style-type: none"> ● 燃えやすいものの側での溶接作業は絶対にしてはなりません。 	<ul style="list-style-type: none"> ● 目、耳及び身体に保護具をして下さい。
Chinese 警告	<ul style="list-style-type: none"> ● 皮肤或湿衣物切勿接触带电部件及焊条。 ● 使你自已与地面和工作件绝缘。 	<ul style="list-style-type: none"> ● 把一切易燃物品移离工作场所。 	<ul style="list-style-type: none"> ● 佩戴眼、耳及身体劳动保护用具。
Korean 위험	<ul style="list-style-type: none"> ● 전도체나 용접봉을 젖은 형갑 또는 피부로 절대 접촉치 마십시오. ● 모재와 접지를 접촉치 마십시오. 	<ul style="list-style-type: none"> ● 인화성 물질을 접근시키지 마십시오. 	<ul style="list-style-type: none"> ● 눈, 귀와 몸에 보호장구를 착용하십시오.
Arabic تحذير	<ul style="list-style-type: none"> ● لا تلمس الاجزاء التي يسري فيها التيار الكهربائي أو الالكترود بجند الجسم أو بالملابس المبللة بالماء. ● وضع عازلا على جسمك خلال العمل. 	<ul style="list-style-type: none"> ● ضع المواد القابلة للاشتعال في مكان بعيد. 	<ul style="list-style-type: none"> ● ضع أدوات وملابس واقية على عينيك وأذنيك وجسمك.

READ AND UNDERSTAND THE MANUFACTURER'S INSTRUCTION FOR THIS EQUIPMENT AND THE CONSUMABLES TO BE USED AND FOLLOW YOUR EMPLOYER'S SAFETY PRACTICES.

SE RECOMIENDA LEER Y ENTENDER LAS INSTRUCCIONES DEL FABRICANTE PARA EL USO DE ESTE EQUIPO Y LOS CONSUMIBLES QUE VA A UTILIZAR, SIGA LAS MEDIDAS DE SEGURIDAD DE SU SUPERVISOR.

LISEZ ET COMPRENEZ LES INSTRUCTIONS DU FABRICANT EN CE QUI REGARDE CET EQUIPMENT ET LES PRODUITS A ETRE EMPLOYES ET SUIVEZ LES PROCEDURES DE SECURITE DE VOTRE EMPLOYEUR.

LESEN SIE UND BEFOLGEN SIE DIE BETRIEBSANLEITUNG DER ANLAGE UND DEN ELEKTRODENEINSATZ DES HERSTELLERS. DIE UNFALLVERHÜTUNGSVORSCHRIFTEN DES ARBEITGEBERS SIND EBENFALLS ZU BEACHTEN.

			
<ul style="list-style-type: none"> ● Keep your head out of fumes. ● Use ventilation or exhaust to remove fumes from breathing zone. 	<ul style="list-style-type: none"> ● Turn power off before servicing. 	<ul style="list-style-type: none"> ● Do not operate with panel open or guards off. 	WARNING
<ul style="list-style-type: none"> ● Los humos fuera de la zona de respiración. ● Mantenga la cabeza fuera de los humos. Utilice ventilación o aspiración para gases. 	<ul style="list-style-type: none"> ● Desconectar el cable de alimentación de poder de la máquina antes de iniciar cualquier servicio. 	<ul style="list-style-type: none"> ● No operar con panel abierto o guardas quitadas. 	Spanish AVISO DE PRECAUCION
<ul style="list-style-type: none"> ● Gardez la tête à l'écart des fumées. ● Utilisez un ventilateur ou un aspirateur pour ôter les fumées des zones de travail. 	<ul style="list-style-type: none"> ● Débranchez le courant avant l'entretien. 	<ul style="list-style-type: none"> ● N'opérez pas avec les panneaux ouverts ou avec les dispositifs de protection enlevés. 	French ATTENTION
<ul style="list-style-type: none"> ● Vermeiden Sie das Einatmen von Schweißrauch! ● Sorgen Sie für gute Be- und Entlüftung des Arbeitsplatzes! 	<ul style="list-style-type: none"> ● Strom vor Wartungsarbeiten abschalten! (Netzstrom völlig öffnen; Maschine anhalten!) 	<ul style="list-style-type: none"> ● Anlage nie ohne Schutzgehäuse oder Innenschutzverkleidung in Betrieb setzen! 	German WARNUNG
<ul style="list-style-type: none"> ● Mantenha seu rosto da fumaça. ● Use ventilação e exaustão para remover fumo da zona respiratória. 	<ul style="list-style-type: none"> ● Não opere com as tampas removidas. ● Desligue a corrente antes de fazer serviço. ● Não toque as partes elétricas nuas. 	<ul style="list-style-type: none"> ● Mantenha-se afastado das partes moventes. ● Não opere com os painéis abertos ou guardas removidas. 	Portuguese ATENÇÃO
<ul style="list-style-type: none"> ● ヒュームから頭を離すようにして下さい。 ● 換気や排煙に十分留意して下さい。 	<ul style="list-style-type: none"> ● メンテナンス・サービスに取りかかる際には、まず電源スイッチを必ず切して下さい。 	<ul style="list-style-type: none"> ● パネルやカバーを取り外したまま機械操作をしないで下さい。 	Japanese 注意事項
<ul style="list-style-type: none"> ● 頭部遠離煙霧。 ● 在呼吸區使用通風或排風器除煙。 	<ul style="list-style-type: none"> ● 維修前切斷電源。 	<ul style="list-style-type: none"> ● 儀表板打開或沒有安全罩時不準作業。 	Chinese 警告
<ul style="list-style-type: none"> ● 얼굴로부터 용접가스를 멀리하십시오. ● 호흡지역으로부터 용접가스를 제거하기 위해 가스제거기나 통풍기를 사용하십시오. 	<ul style="list-style-type: none"> ● 보수전에 전원을 차단하십시오. 	<ul style="list-style-type: none"> ● 판넬이 열린 상태로 작동치 마십시오. 	Korean 위험
<ul style="list-style-type: none"> ● ابعِد رأسك بعيداً عن الدخان. ● استعمل التهوية أو جهاز ضغط الدخان للخارج لكي تبعد الدخان عن المنطقة التي تتنفس فيها. 	<ul style="list-style-type: none"> ● اقطع التيار الكهربائي قبل القيام بأية صيانة. 	<ul style="list-style-type: none"> ● لا تشغيل هذا الجهاز اذا كانت الاغطية الحديدية الواقية ليست عليه. 	Arabic تحذير

LEIA E COMPREENDA AS INSTRUÇÕES DO FABRICANTE PARA ESTE EQUIPAMENTO E AS PARTES DE USO, E SIGA AS PRÁTICAS DE SEGURANÇA DO EMPREGADOR.

使う機械や溶材のメーカーの指示書をよく読み、まず理解して下さい。そして貴社の安全規定に従って下さい。

請詳細閱讀並理解製造廠提供的說明以及應該使用的銀焊材料，並請遵守貴方的有閣勞動保護規定。

이 제품에 동봉된 작업지침서를 숙지하시고 귀사의 작업자 안전수칙을 준수하시기 바랍니다.

اقرأ بتمعن وافهم تعليمات المصنع المنتج لهذه المعدات والمواد قبل استعمالها واتبع تعليمات الوقاية لصاحب العمل.

CUSTOMER ASSISTANCE POLICY

The business of Lincoln Electric is manufacturing and selling high quality welding equipment, automated welding systems, consumables, and cutting equipment. Our challenge is to meet the needs of our customers, who are experts in their fields, and to exceed their expectations. On occasion, purchasers may ask Lincoln Electric for information or technical information about their use of our products. Our employees respond to inquiries to the best of their ability based on information and specifications provided to them by the customers and the knowledge they may have concerning the application. Our employees, however, are not in a position to verify the information provided or to evaluate the engineering requirements for the particular weldment, or to provide engineering advice in relation to a specific situation or application. Accordingly, Lincoln Electric does not warrant or guarantee or assume any liability with respect to such information or communications. Moreover, the provision of such information or technical information does not create, expand, or alter any warranty on our products. Any express or implied warranty that might arise from the information or technical information, including any implied warranty of merchantability or any warranty of fitness for any customers' particular purpose or any other equivalent or similar warranty is specifically disclaimed.

Lincoln Electric is a responsive manufacturer, but the definition of specifications, and the selection and use of specific products sold by Lincoln Electric is solely within the control of, and remains the sole responsibility of the customer. Many variables beyond the control of Lincoln Electric affect the results obtained in applying these types of fabrication methods and service requirements.

WELD FUME CONTROL EQUIPMENT

The operation of welding fume control equipment is affected by various factors including proper use and positioning of the equipment, maintenance of the equipment and the specific welding procedure and application involved. Worker exposure level should be checked upon installation and periodically thereafter to be certain it is within applicable OSHA PEL and ACGIH TLV limits.



THE LINCOLN ELECTRIC COMPANY

22801 St. Clair Avenue • Cleveland, OH • 44117-1199 • U.S.A.
Phone: +1.216.481.8100 • www.lincolnelectric.com