

Operator's Manual

ASPECT™ 375

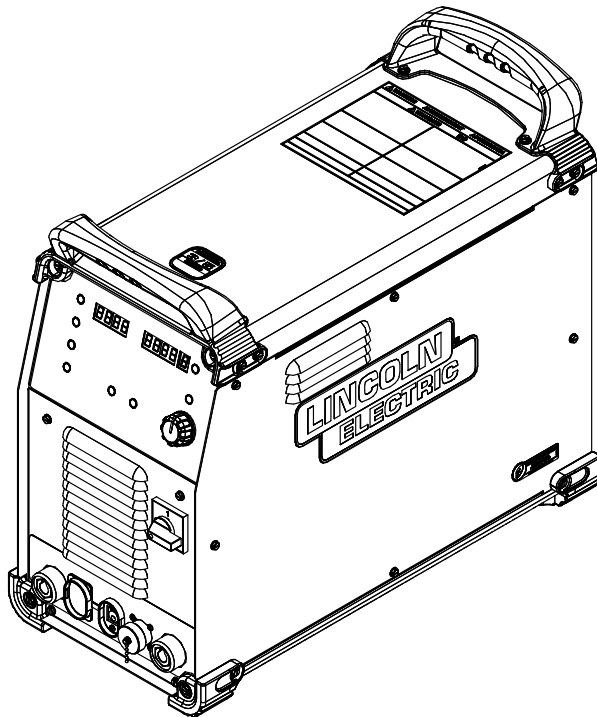

For use with machines having Code Numbers:
12165, 12548, 12558



Register your machine:
www.lincolnelectric.com/registration

Authorized Service and Distributor Locator:
www.lincolnelectric.com/locator

Save for future reference

Date Purchased

Code: (ex: 10859)

Serial: (ex: U1060512345)

THANK YOU FOR SELECTING A QUALITY PRODUCT BY LINCOLN ELECTRIC.

PLEASE EXAMINE CARTON AND EQUIPMENT FOR DAMAGE IMMEDIATELY

When this equipment is shipped, title passes to the purchaser upon receipt by the carrier. Consequently, claims for material damaged in shipment must be made by the purchaser against the transportation company at the time the shipment is received.

SAFETY DEPENDS ON YOU

Lincoln arc welding and cutting equipment is designed and built with safety in mind. However, your overall safety can be increased by proper installation ... and thoughtful operation on your part. **DO NOT INSTALL, OPERATE OR REPAIR THIS EQUIPMENT WITHOUT READING THIS MANUAL AND THE SAFETY PRECAUTIONS CONTAINED THROUGHOUT.** And, most importantly, think before you act and be careful.

WARNING

This statement appears where the information must be followed exactly to avoid serious personal injury or loss of life.

CAUTION

This statement appears where the information must be followed to avoid minor personal injury or damage to this equipment.



KEEP YOUR HEAD OUT OF THE FUMES.

DON'T get too close to the arc. Use corrective lenses if necessary to stay a reasonable distance away from the arc.

READ and obey the Safety Data Sheet (SDS) and the warning label that appears on all containers of welding materials.

USE ENOUGH VENTILATION or exhaust at the arc, or both, to keep the fumes and gases from your breathing zone and the general area.

IN A LARGE ROOM OR OUTDOORS, natural ventilation may be adequate if you keep your head out of the fumes (See below).

USE NATURAL DRAFTS or fans to keep the fumes away from your face.

If you develop unusual symptoms, see your supervisor. Perhaps the welding atmosphere and ventilation system should be checked.



WEAR CORRECT EYE, EAR & BODY PROTECTION

PROTECT your eyes and face with welding helmet properly fitted and with proper grade of filter plate (See ANSI Z49.1).

PROTECT your body from welding spatter and arc flash with protective clothing including woolen clothing, flame-proof apron and gloves, leather leggings, and high boots.

PROTECT others from splatter, flash, and glare with protective screens or barriers.

IN SOME AREAS, protection from noise may be appropriate.

BE SURE protective equipment is in good condition.

Also, wear safety glasses in work area **AT ALL TIMES.**



SPECIAL SITUATIONS

DO NOT WELD OR CUT containers or materials which previously had been in contact with hazardous substances unless they are properly cleaned. This is extremely dangerous.

DO NOT WELD OR CUT painted or plated parts unless special precautions with ventilation have been taken. They can release highly toxic fumes or gases.

Additional precautionary measures

PROTECT compressed gas cylinders from excessive heat, mechanical shocks, and arcs; fasten cylinders so they cannot fall.

BE SURE cylinders are never grounded or part of an electrical circuit.

REMOVE all potential fire hazards from welding area.

ALWAYS HAVE FIRE FIGHTING EQUIPMENT READY FOR IMMEDIATE USE AND KNOW HOW TO USE IT.



SECTION A: WARNINGS



CALIFORNIA PROPOSITION 65 WARNINGS



WARNING: Breathing diesel engine exhaust exposes you to chemicals known to the State of California to cause cancer and birth defects, or other reproductive harm.

- Always start and operate the engine in a well-ventilated area.
- If in an exposed area, vent the exhaust to the outside.
- Do not modify or tamper with the exhaust system.
- Do not idle the engine except as necessary.

For more information go to www.P65warnings.ca.gov/diesel

WARNING: This product, when used for welding or cutting, produces fumes or gases which contain chemicals known to the State of California to cause birth defects and, in some cases, cancer. (California Health & Safety Code § 25249.5 *et seq.*)



WARNING: Cancer and Reproductive Harm
www.P65warnings.ca.gov

ARC WELDING CAN BE HAZARDOUS. PROTECT YOURSELF AND OTHERS FROM POSSIBLE SERIOUS INJURY OR DEATH. KEEP CHILDREN AWAY. PACEMAKER WEARERS SHOULD CONSULT WITH THEIR DOCTOR BEFORE OPERATING.

Read and understand the following safety highlights. For additional safety information, it is strongly recommended that you purchase a copy of "Safety in Welding & Cutting - ANSI Standard Z49.1" from the American Welding Society, P.O. Box 351040, Miami, Florida 33135 or CSA Standard W117.2. A Free copy of "Arc Welding Safety" booklet E205 is available from the Lincoln Electric Company, 22801 St. Clair Avenue, Cleveland, Ohio 44117-1199.

BE SURE THAT ALL INSTALLATION, OPERATION, MAINTENANCE AND REPAIR PROCEDURES ARE PERFORMED ONLY BY QUALIFIED INDIVIDUALS.



FOR ENGINE POWERED EQUIPMENT.

- Turn the engine off before troubleshooting and maintenance work unless the maintenance work requires it to be running.
- Operate engines in open, well-ventilated areas or vent the engine exhaust fumes outdoors.
- Do not add the fuel near an open flame welding arc or when the engine is running. Stop the engine and allow it to cool before refueling to prevent spilled fuel from vaporizing on contact



with hot engine parts and igniting. Do not spill fuel when filling tank. If fuel is spilled, wipe it up and do not start engine until fumes have been eliminated.

- Keep all equipment safety guards, covers and devices in position and in good repair. Keep hands, hair, clothing and tools away from V-belts, gears, fans and all other moving parts when starting, operating or repairing equipment.
- In some cases it may be necessary to remove safety guards to perform required maintenance. Remove guards only when necessary and replace them when the maintenance requiring their removal is complete. Always use the greatest care when working near moving parts.
- Do not put your hands near the engine fan. Do not attempt to override the governor or idler by pushing on the throttle control rods while the engine is running.
- To prevent accidentally starting gasoline engines while turning the engine or welding generator during maintenance work, disconnect the spark plug wires, distributor cap or magneto wire as appropriate.
- To avoid scalding, do not remove the radiator pressure cap when the engine is hot.
- Using a generator indoors CAN KILL YOU IN MINUTES.
- Generator exhaust contains carbon monoxide. This is a poison you cannot see or smell.
- NEVER use inside a home or garage, EVEN IF doors and windows are open.
- Only use OUTSIDE and far away from windows, doors and vents.
- Avoid other generator hazards. READ MANUAL BEFORE USE.



ELECTRIC AND MAGNETIC FIELDS MAY BE DANGEROUS



- Electric current flowing through any conductor causes localized Electric and Magnetic Fields (EMF). Welding current creates EMF fields around welding cables and welding machines
- EMF fields may interfere with some pacemakers, and welders having a pacemaker should consult their physician before welding.
- Exposure to EMF fields in welding may have other health effects which are now not known.
- All welders should use the following procedures in order to minimize exposure to EMF fields from the welding circuit:
 - Route the electrode and work cables together - Secure them with tape when possible.
 - Never coil the electrode lead around your body.
 - Do not place your body between the electrode and work cables. If the electrode cable is on your right side, the work cable should also be on your right side.
 - Connect the work cable to the workpiece as close as possible to the area being welded.
 - Do not work next to welding power source.



ELECTRIC SHOCK CAN KILL.



- 3.a. The electrode and work (or ground) circuits are electrically “hot” when the welder is on. Do not touch these “hot” parts with your bare skin or wet clothing. Wear dry, hole-free gloves to insulate hands.
- 3.b. Insulate yourself from work and ground using dry insulation. Make certain the insulation is large enough to cover your full area of physical contact with work and ground.

In addition to the normal safety precautions, if welding must be performed under electrically hazardous conditions (in damp locations or while wearing wet clothing; on metal structures such as floors, gratings or scaffolds; when in cramped positions such as sitting, kneeling or lying, if there is a high risk of unavoidable or accidental contact with the workpiece or ground) use the following equipment:

- Semiautomatic DC Constant Voltage (Wire) Welder.
 - DC Manual (Stick) Welder.
 - AC Welder with Reduced Voltage Control.
- 3.c. In semiautomatic or automatic wire welding, the electrode, electrode reel, welding head, nozzle or semiautomatic welding gun are also electrically “hot”.
 - 3.d. Always be sure the work cable makes a good electrical connection with the metal being welded. The connection should be as close as possible to the area being welded.
 - 3.e. Ground the work or metal to be welded to a good electrical (earth) ground.
 - 3.f. Maintain the electrode holder, work clamp, welding cable and welding machine in good, safe operating condition. Replace damaged insulation.
 - 3.g. Never dip the electrode in water for cooling.
 - 3.h. Never simultaneously touch electrically “hot” parts of electrode holders connected to two welders because voltage between the two can be the total of the open circuit voltage of both welders.
 - 3.i. When working above floor level, use a safety belt to protect yourself from a fall should you get a shock.
 - 3.j. Also see Items 6.c. and 8.



ARC RAYS CAN BURN.



- 4.a. Use a shield with the proper filter and cover plates to protect your eyes from sparks and the rays of the arc when welding or observing open arc welding. Headshield and filter lens should conform to ANSI Z87.1 standards.
- 4.b. Use suitable clothing made from durable flame-resistant material to protect your skin and that of your helpers from the arc rays.
- 4.c. Protect other nearby personnel with suitable, non-flammable screening and/or warn them not to watch the arc nor expose themselves to the arc rays or to hot spatter or metal.



FUMES AND GASES CAN BE DANGEROUS.



- 5.a. Welding may produce fumes and gases hazardous to health. Avoid breathing these fumes and gases. When welding, keep your head out of the fume. Use enough ventilation and/or exhaust at the arc to keep fumes and gases away from the breathing zone. **When welding hardfacing (see instructions on container or SDS) or on lead or cadmium plated steel and other metals or coatings which produce highly toxic fumes, keep exposure as low as possible and within applicable OSHA PEL and ACGIH TLV limits using local exhaust or mechanical ventilation unless exposure assessments indicate otherwise. In confined spaces or in some circumstances, outdoors, a respirator may also be required. Additional precautions are also required when welding on galvanized steel.**
- 5.b. The operation of welding fume control equipment is affected by various factors including proper use and positioning of the equipment, maintenance of the equipment and the specific welding procedure and application involved. Worker exposure level should be checked upon installation and periodically thereafter to be certain it is within applicable OSHA PEL and ACGIH TLV limits.
- 5.c. Do not weld in locations near chlorinated hydrocarbon vapors coming from degreasing, cleaning or spraying operations. The heat and rays of the arc can react with solvent vapors to form phosgene, a highly toxic gas, and other irritating products.
- 5.d. Shielding gases used for arc welding can displace air and cause injury or death. Always use enough ventilation, especially in confined areas, to insure breathing air is safe.
- 5.e. Read and understand the manufacturer’s instructions for this equipment and the consumables to be used, including the Safety Data Sheet (SDS) and follow your employer’s safety practices. SDS forms are available from your welding distributor or from the manufacturer.
- 5.f. Also see item 1.b.



WELDING AND CUTTING SPARKS CAN CAUSE FIRE OR EXPLOSION.



- 6.a. Remove fire hazards from the welding area. If this is not possible, cover them to prevent the welding sparks from starting a fire. Remember that welding sparks and hot materials from welding can easily go through small cracks and openings to adjacent areas. Avoid welding near hydraulic lines. Have a fire extinguisher readily available.
- 6.b. Where compressed gases are to be used at the job site, special precautions should be used to prevent hazardous situations. Refer to "Safety in Welding and Cutting" (ANSI Standard Z49.1) and the operating information for the equipment being used.
- 6.c. When not welding, make certain no part of the electrode circuit is touching the work or ground. Accidental contact can cause overheating and create a fire hazard.
- 6.d. Do not heat, cut or weld tanks, drums or containers until the proper steps have been taken to insure that such procedures will not cause flammable or toxic vapors from substances inside. They can cause an explosion even though they have been "cleaned". For information, purchase "Recommended Safe Practices for the Preparation for Welding and Cutting of Containers and Piping That Have Held Hazardous Substances", AWS F4.1 from the American Welding Society (see address above).
- 6.e. Vent hollow castings or containers before heating, cutting or welding. They may explode.
- 6.f. Sparks and spatter are thrown from the welding arc. Wear oil free protective garments such as leather gloves, heavy shirt, cuffless trousers, high shoes and a cap over your hair. Wear ear plugs when welding out of position or in confined places. Always wear safety glasses with side shields when in a welding area.
- 6.g. Connect the work cable to the work as close to the welding area as practical. Work cables connected to the building framework or other locations away from the welding area increase the possibility of the welding current passing through lifting chains, crane cables or other alternate circuits. This can create fire hazards or overheat lifting chains or cables until they fail.
- 6.h. Also see item 1.c.
- 6.i. Read and follow NFPA 51B "Standard for Fire Prevention During Welding, Cutting and Other Hot Work", available from NFPA, 1 Batterymarch Park, PO box 9101, Quincy, MA 022690-9101.
- 6.j. Do not use a welding power source for pipe thawing.



CYLINDER MAY EXPLODE IF DAMAGED.



- 7.a. Use only compressed gas cylinders containing the correct shielding gas for the process used and properly operating regulators designed for the gas and pressure used. All hoses, fittings, etc. should be suitable for the application and maintained in good condition.
- 7.b. Always keep cylinders in an upright position securely chained to an undercarriage or fixed support.
- 7.c. Cylinders should be located:
 - Away from areas where they may be struck or subjected to physical damage.
 - A safe distance from arc welding or cutting operations and any other source of heat, sparks, or flame.
- 7.d. Never allow the electrode, electrode holder or any other electrically "hot" parts to touch a cylinder.
- 7.e. Keep your head and face away from the cylinder valve outlet when opening the cylinder valve.
- 7.f. Valve protection caps should always be in place and hand tight except when the cylinder is in use or connected for use.
- 7.g. Read and follow the instructions on compressed gas cylinders, associated equipment, and CGA publication P-1, "Precautions for Safe Handling of Compressed Gases in Cylinders," available from the Compressed Gas Association, 14501 George Carter Way Chantilly, VA 20151.



FOR ELECTRICALLY POWERED EQUIPMENT.



- 8.a. Turn off input power using the disconnect switch at the fuse box before working on the equipment.
- 8.b. Install equipment in accordance with the U.S. National Electrical Code, all local codes and the manufacturer's recommendations.
- 8.c. Ground the equipment in accordance with the U.S. National Electrical Code and the manufacturer's recommendations.

Refer to
<http://www.lincolnelectric.com/safety>
for additional safety information.

Installation.....	Section A
Technical Specifications.....	A-1
Safety Precautions.....	A-2
Suitable Location.....	A-2
Grinding.....	A-2
Stacking.....	A-2
Lifting.....	A-2
Tilting.....	A-2
Enclosure Rating.....	A-2
Machine Grounding.....	A-2
Input Connection.....	A-3
Input Fuse and Supply Wire.....	A-3
Input Voltage.....	A-3
Power Cord Replacement.....	A-4
Connection Diagrams for the ASPECT™ 375.....	A-6 thru A-8
Water Cooled TIG Torch With Wired Foot Pedal.....	A-6
Air Cooled TIG Torch with Wired Foot Pedal.....	A-7
Stick (SMAW) Welding.....	A-8
Operation.....	Section B
Case Front Controls.....	B-1
Case Back Controls.....	B-2
Graphic Symbols Appearing in this Machine or Manual.....	B-3, B4
User Interface Controls.....	B-5 thru B-11
Polarity, Process, Output Control.....	B-6
4-Step Functionality, Output On.....	B-7
AC Waveshape.....	B-8
Sequencer Functions, Pulse Sequencer Functions.....	B-9
Memory Selection, Saving Memory Settings.....	B-10
Memory Recall Settings, Status Lights.....	B-11
Setup Menu “GTAW”.....	B-12
Setup Menu “SMAW”.....	B-13
Setup Menu “SYS”.....	B-14
Appendix.....	B-15, B-16
Accessories.....	Section C
General Options / Accessories.....	C-1
Field Installed.....	C-1
Maintenance.....	Section D
Safety Precautions.....	D-1
Routine and Periodic Engine Maintenance.....	D-1
Over Load Protection.....	D-1
Thermostatic Protection.....	D-1
No Arc Protection.....	D-1
Auxiliary Power Circuit Breaker.....	D-1
Troubleshooting.....	Section E
Safety Precautions.....	E-1
How to Use Troubleshooting Guide.....	E-1
Troubleshooting Guide.....	E-2 thru E-10
Wiring Diagrams and Dimension Print.....	Section F
Parts List.....	parts.lincolnelectric.com

Content/details may be changed or updated without notice. For most current Instruction Manuals, go to parts.lincolnelectric.com.

The ASPECT™ 375 is part of a new family of inverter based arc welding power sources optimized for AC/DC TIG (GTAW) and AC/DC Stick (SMAW) welding. The ASPECT™ 375 includes TIG features such as Intellistart™ AC Auto Balance®, Manual AC Balance, AC Output Frequency, Amplitude Control, High frequency and Touch Start TIG®, 9 memory settings, Full sequencer including pulse controls, 2-step and 4-step output, Full digital controls, and Fan As Needed (F.A.N.). The ASPECT™ 375 also features four AC TIG wave forms including Square Wave, Soft Square Wave, Sine Wave and Triangle Wave. Additionally, Soft Stick and Crisp Stick welding modes are available.

A new TIG Welding Cart (with pivoting easy load bottle holder) and the new Cool Arc® 47 are both available as field installed options, or the entire system with welding power source is available as a fully integrated Ready-Pak®.

RECOMMENDED PROCESSES

The ASPECT™ 375 is recommended for manual GTAW and SMAW welding (AC and DC).

RECOMMENDED EQUIPMENT

Cooler: Cool Arc® 47 (K3950-1)

Low Conductivity Coolant (1 gal.) (KP4159-1)

Cart: TIG Welding Cart (K3949-1)

Regulator with Flow Gauge and Hose Kit (3100211)

Torch: K4843-18F-2 CALIBER PTW-18 TORCH

PTA-26 200 Amp Air Cooled Torch w/1 pc. 25' (7.6m)
Cable (K1783-3)

Twist-Mate™ Adapter: (K1622-5) (For use with 20H-320-25R Torch)

(K1622-3) (For use with PTA-26 TIG Torch)

Foot Amptrol: with 25' (7.6m) Cable Assembly: (K870)

Work Lead: 15 foot lead with Twist-Mate™ plug (K1803-3)

Consumable Kit: KP4760-HD CALIBER PTW-18 TORCH PARTS
(KP509) (for use with PTA-26 and PTW-18)

PROCESS LIMITATIONS

The ASPECT™ 375 is not recommended for pipe thawing or for arc gouging.

EQUIPMENT LIMITATIONS

The ASPECT™ 375 is protected from overloading beyond the rated duty cycle and outputs of the machine. The duty cycle is based upon a 10 minute time period; a 30% duty cycle refers to 3 minutes of welding and 7 minutes of idling. If the duty cycle is significantly exceeded, the thermostatic protection will shut off the output until the machine cools to a normal operating temperature.

TECHNICAL SPECIFICATIONS ASPECT™ 375 (K3945-1, K3945-2)

POWER SOURCE INPUT VOLTAGE AND CURRENT		
Duty Cycle	Input Amperes (1 Phase in Parentheses)	
30%	25/23/13/11/9 (30/27/NA/NA/NA)	
60%	29/26/15/12/10 (34/31/NA/NA/NA)	
100%	29/27/16/13/10 (34/31/NA/NA/NA)	
Input Voltage ± 10%	Idle Power	Power Factor @ Rated Output
208/230**/400*/460/575 50/60 Hz (*includes 380 to 413 V) (*includes 220 V)	100 Watts Max.	.95

RATED OUTPUT			
Input Power		Duty Cycle	Rated Output Current and Voltage
PHASE	Voltage Frequency		
THREE PHASE	200-600/50/60	100%	GTAW 250 A / 20 V SMAW 250 A / 30 V
		60%	GTAW 300 A / 22 V SMAW 300 A / 32 V
		30%	GTAW 350 A / 24 V SMAW 350 A / 34 V
SINGLE PHASE	200-230/50/60	100%	GTAW 180 A / 17.2 V SMAW 180 A / 27.2 V
		60%	GTAW 225 A / 19 V SMAW 225 A / 29 V
		30%	GTAW 250 A / 20 V SMAW 250 A / 30 V

OUTPUT RANGE			
Phase	Type of Output	Output Current Range	Maximum Open Circuit Voltage
THREE PHASE	GTAW AC/DC SMAW AC/DC	2-375 Amps 20-350 Amps	108 Volts Max. 90 Volts Max.
SINGLE PHASE	GTAW AC/DC SMAW AC/DC	2-250 20-250	108 Volts Max. 90 Volts Max.

Thermal tests have been performed at ambient temperature. The duty cycle (duty factor) at 40°C has been determined by simulation.

RECOMMENDED INPUT WIRE AND FUSE SIZES ¹			
INPUT VOLTAGE / PHASE / FREQUENCY	MAXIMUM INPUT AMPERE RATING	CORD SIZE ³ AWG SIZES (mm ²)	TIME DELAY FUSE OR BREAKER ² AMPERAGE
200-208/1/50/60 230/1/50/60	50 A	8 (8.3)	60
	47 A	8 (8.3)	60
200-208/3/50/60 230/3/50/60	46 A	10 (5.3)	60
	42 A	10 (5.3)	50
380-415/3/50/60 460/3/50/60 575/3/50/60	24 A	14 (2.1)	35
	20 A	14 (2.1)	30
	16 A	14 (2.1)	20

PHYSICAL DIMENSIONS			
HEIGHT	WIDTH	DEPTH	WEIGHT
21.00 in. 533 mm	11.8 in. 300 mm	25.00 in. 635 mm	105 lbs. (48kg.)

TEMPERATURE RANGES
OPERATING TEMPERATURE RANGE -20°C to +40°C (-4°F to +104°F)
STORAGE TEMPERATURE RANGE -40°C to +85°C (-40°F to +185°F)

IP23

1. Based on U.S. National electrical Code
2. Also called "inverse time" or "thermal / magnetic" circuit breakers; circuit breakers that have a delay in tripping action that decreases as the magnitude of the current increases
3. Type SO cord or similar in 30° C ambient

SAFETY PRECAUTIONS

Read entire installation section before starting installation.

WARNING

ELECTRIC SHOCK can kill.

- Only qualified personnel should perform this installation.
- Turn the input power OFF at the disconnect switch or fuse box before working on this equipment.
- Do not touch electrically hot parts.
- Always connect the ASPECT™ 375 grounding screw (behind the terminal block located near the back of the right case side) to a good electrical earth ground.
- Always connect the ASPECT™ 375 to a power supply grounded in accordance with the National Electrical Code and all local codes.



SELECT SUITABLE LOCATION

Place the welder where clean cooling air can freely circulate in through the front vents and out through the rear vents. Dirt, dust or any foreign material that can be drawn into the welder should be kept at a minimum. Failure to observe these precautions can result in excessive operating temperatures and nuisance trips.

GRINDING

Do not direct grinding particles towards the welder. An abundance of conductive material can cause maintenance problems.

STACKING

The ASPECT™ 375 cannot be stacked .

UNDERCARRIAGE LIFTING AND MOVING

When the ASPECT™ 375 is purchased as a welding package, or used with any of the available Undercarriage optional accessories, proper installation makes the ASPECT™ 375 handles nonfunctional. Do not attempt to lift the power source with an undercarriage attached. The undercarriage is designed for hand moving only; mechanized movement can lead to personal injury and/or damage to the ASPECT™ 375.

TILTING

Each machine must be placed on a secure, level surface, either directly or on a recommended cart. The machine may topple over if this precaution is not followed.

ENCLOSURE RATING

ASPECT™ 375 power sources carry an IP23 Enclosure rating. They are rated for use in damp, dirty rain-sheltered environments.

MACHINE GROUNDING AND HIGH FREQUENCY INTERFERENCE PROTECTION

Locate the ASPECT™ 375 away from radio controlled machinery. The normal operation of the ASPECT™ 375 may adversely affect the operation of RF controlled equipment, which may result in bodily injury or damage to the equipment.

The frame of the welder must be grounded. A ground screw marked with the symbol  is located on the rear panel (Figure A.1) for this purpose. See your local and national electrical codes for proper grounding methods.

The high frequency generator, being similar to a radio transmitter, can be blamed for many radio, TV and electronic equipment interference problems. These problems may be the result of radiated interference. Proper grounding methods can reduce or eliminate radiated interference.

Radiated interference can develop in the following four ways:

- Direct interference radiated from the welder.
- Direct interference radiated from the welding leads.
- Direct interference radiated from feedback into the power lines.
- Interference from re-radiation of "pickup" by ungrounded metallic objects.

Keeping these contributing factors in mind, installing the equipment per the following instructions should minimize problems:

1. Keep the welder power supply lines as short as possible. Input leads within 50 feet (15.2 m) of the welder should be enclosed in rigid metallic conduit or equivalent shielding. There must be good electrical contact between this conduit and the welder. Both ends of the conduit must be connected to a driven ground and the entire length must be continuous.
2. Keep the work and electrode leads as short as possible and as close together as possible. Lengths should not exceed 25 feet (7.6 m). Tape the leads together when practical.

3. Be sure the torch and work cable rubber coverings are free of cuts and cracks that allow high frequency leakage. Cables with high natural rubber content, such as Lincoln Stable-Arc®, better resist high frequency leakage than neoprene and other synthetic rubber insulated cables.
4. Keep the torch in good repair and all connections tight to reduce high frequency leakage.
5. The work piece must be connected to an earth ground close to the work clamp, using one of the following methods:
 - A metal underground water pipe in direct contact with the earth for ten feet or more.
 - A 3/4" (19 mm) galvanized pipe or a 5/8" (16 mm) solid galvanized iron, steel or copper rod driven at least eight feet into the ground.

The ground should be securely made and the grounding cable should be as short as possible using cable of the same size as the work cable, or larger. Grounding to the building frame electrical conduit or a long pipe system can result in re-radiation, effectively making these members radiating antennas. (This is not recommended).
6. Keep all access panels and covers securely in place.
7. All electrical conductors within 50 feet (15.2 m) of the welder should be enclosed in grounded rigid metallic conduit or equivalent shielding. Flexible helically-wrapped metallic conduit is generally not suitable.
8. When the welder is enclosed in a metal building, several good earth driven electrical grounds (as in 5 above) around the periphery of the building are recommended.

Failure to observe these recommended installation procedures can cause radio or TV interference problems and result in unsatisfactory welding performance resulting from lost high frequency power.

INPUT CONNECTION

WARNING

Only a qualified electrician should connect the input leads to the ASPECT™ 375. Connections should be made in accordance with all local and national electrical codes and the connection diagrams. Failure to do so may result in bodily injury or death.

A 10 ft. (3m) power cord is provided and wired into the machine.

For Single Phase Input

Connect green lead to ground per National Electrical Code.

Connect black and white leads to power.

Wrap red lead with tape to provide 600V insulation.

For Three Phase Input

Connect green lead to ground per National Electric Code.

Connect black, red and white leads to power.

WARNING

This Class A equipment is not intended for use in residential locations where the electrical power is provided by the public low-voltage supply system. There may be potential difficulties in ensuring electro-magnetic compatibility in those locations, due to conducted as well as radiated disturbances.

INPUT FUSE AND SUPPLY WIRE CONSIDERATIONS

Refer to Specification Section for recommended fuse, wire sizes and type of the copper wires. Fuse the input circuit with the recommended super lag fuse or delay type breakers (also called "inverse time" or "thermal/magnetic" circuit breakers). Choose input and grounding wire size according to local or national electrical codes. Using input wire sizes, fuses or circuit breakers smaller than recommended may result in "nuisance" shut-offs from welder inrush currents, even if the machine is not being used at high currents.

INPUT VOLTAGE SELECTION

The ASPECT™ 375 automatically adjusts to work with different input voltages. No reconnect switches settings are required.

⚠ WARNING

The ASPECT™ 375 ON/OFF switch is not intended as a service disconnect for this equipment. Only a qualified electrician should connect the input leads to the ASPECT™ 375. Connections should be made in accordance with all local and national electrical codes and the connection diagram located on the inside of the right case side. Failure to do so may result in bodily injury or death.

INITIAL INPUT CORD SETUP (FOR K3945-2 ONLY)

For the initial setup of the input cord on the K3945-2 Aspect™ 375, it will be necessary to assemble the provided toroid onto the input ground lead. The toroid will be clamped to the earth ground connection as shown in Figure A.1. Remove and discard the clamp, loop the input ground lead 2 times through the toroid, and then connect it with the grounding lug as shown in Figure A.2.

FIGURE A.1

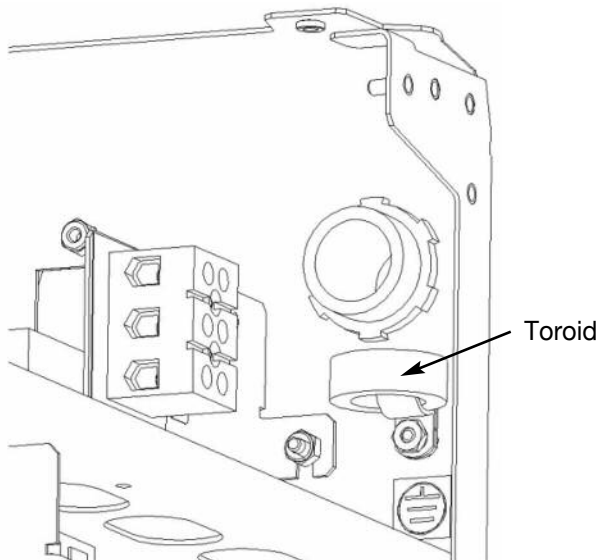
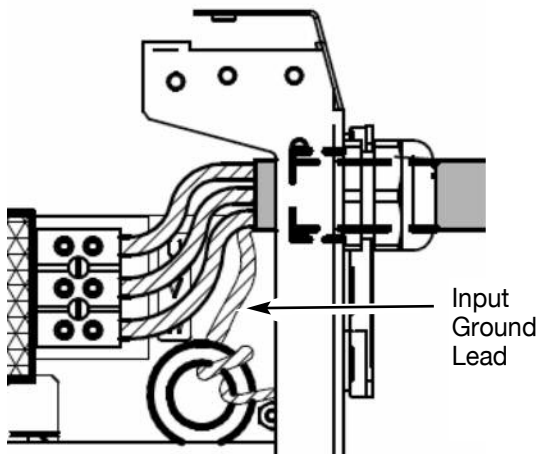

FIGURE A.2



POWER CORD REPLACEMENT

⚠ WARNING

Only a qualified electrician should connect the input leads to the ASPECT™ 375. Connections should be made in accordance with all local and national electrical codes and the connection diagrams. Failure to do so may result in bodily injury or death.

If the **input power cord** is damaged or needs to be replaced an input power **terminal block** is located in the back of the machine with the right case side removed as shown in Figure A.3.

ALWAYS CONNECT THE **GROUNDING LUG** (LOCATED AS SHOWN IN FIGURE A.3) TO A PROPER SAFETY (EARTH) GROUND.

FIGURE A.3

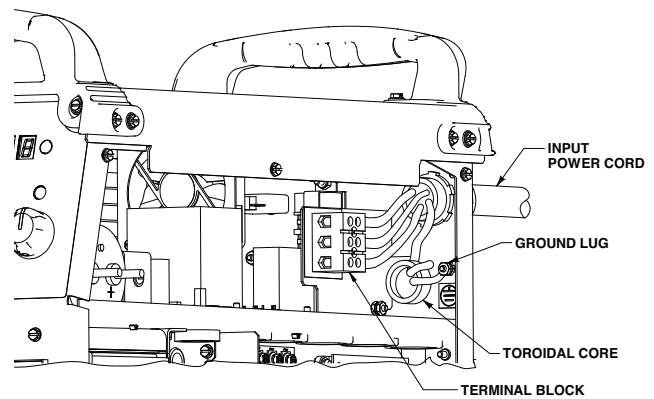

OUTPUT CONNECTIONS

FIGURE A.4

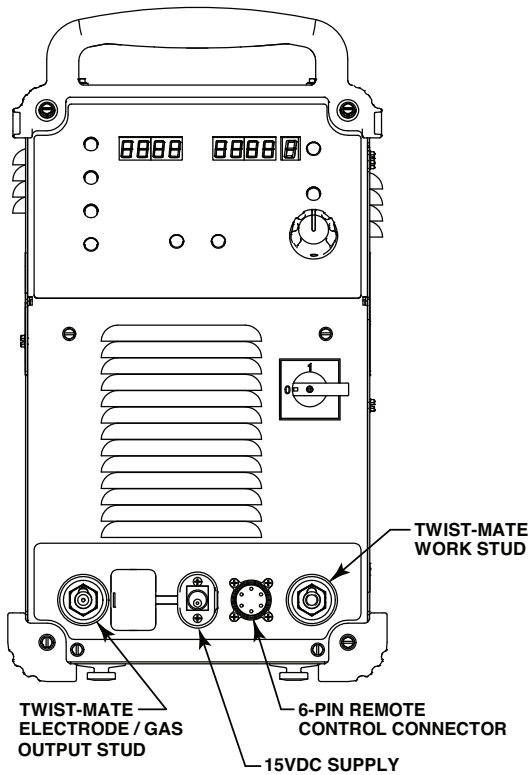

The ASPECT™ 375 is equipped with Twist-Mate style front output studs. To connect cables, turn the power switch "OFF." Connect the torch Twist-mate plug into the electrode gas output receptacle on the front of the machine and turn clockwise until tight. This quick connect terminal also provides the gas connection for the shielding gas to the torch.

Refer to the following connection diagrams for specific information on connecting water cooled and air cooled torches.

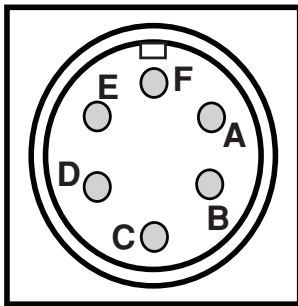

6-PIN REMOTE CONTROL CONNECTOR		
Function	Pin	Wiring
6-pin remote control connector for remote or hand/foot amptrol.	A	77 Remote potentiometer, 5K
	B	76 Remote potentiometer, wiper
	C	75 Remote potentiometer, common
	D	Trigger, common
	E	Trigger, input
	F	Ground

CONNECTION DIAGRAM FOR WATER COOLED TIG TORCH WITH WIRED FOOT PEDAL

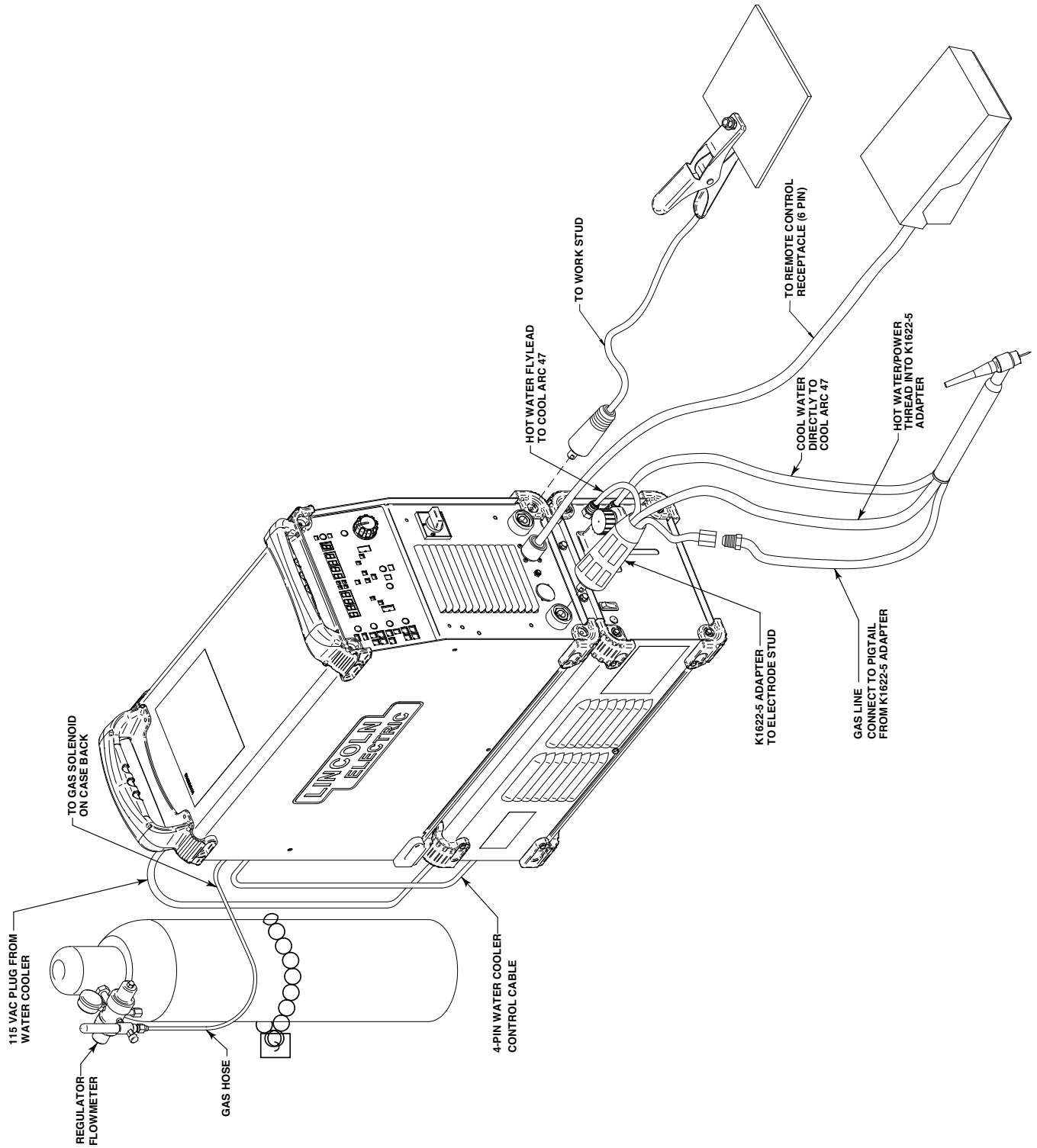

CONNECTION DIAGRAM FOR AIR COOLED TIG TORCH WITH WIRED FOOT PEDAL

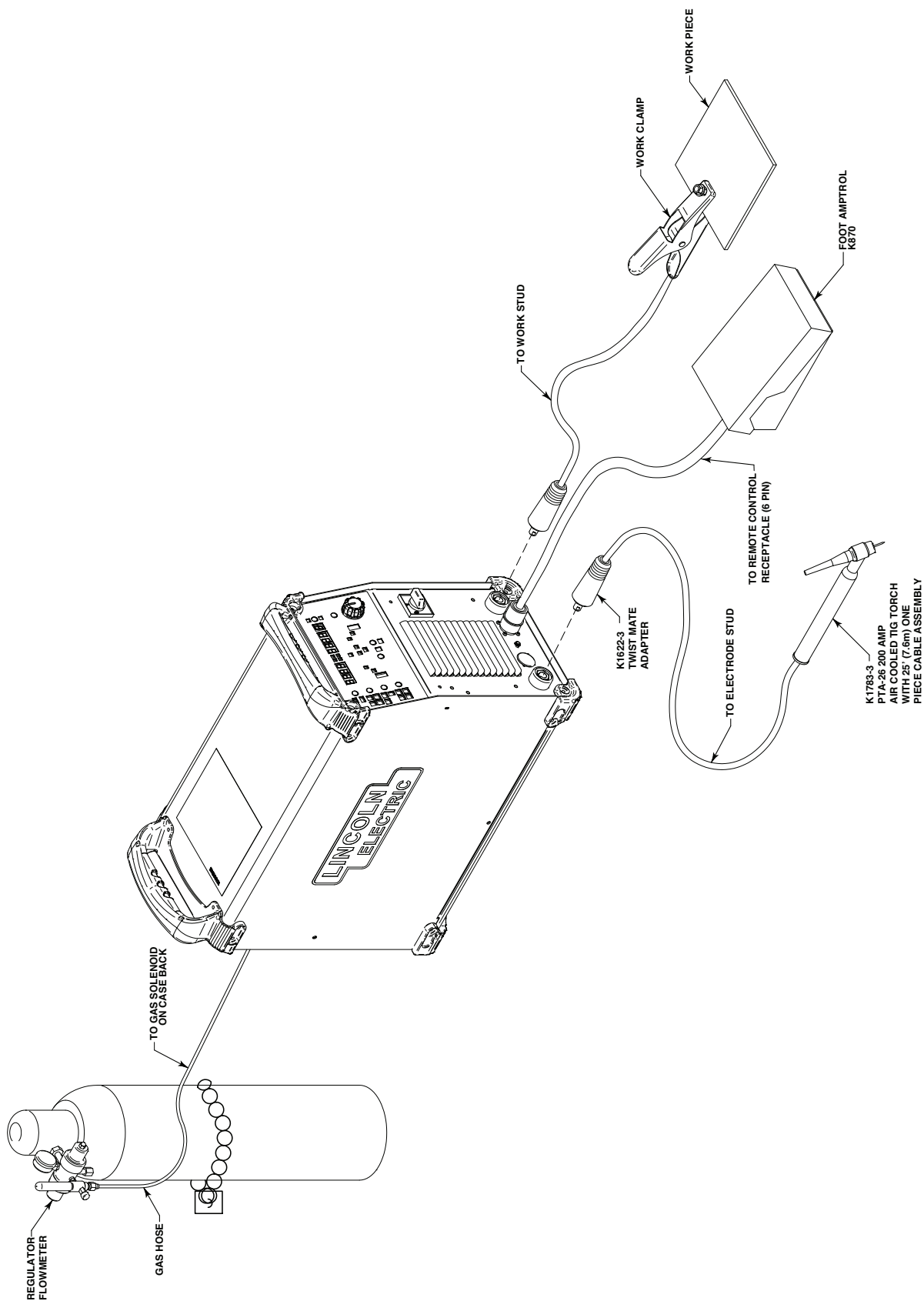

CONNECTION DIAGRAM FOR STICK (SMAW) WELDING

Turn the power switch "OFF." Connect the electrode holder
Twist-Mate to the electrode stud and turn clockwise to tighten.
Connect the work cable Twist-mate to work stud and turn clockwise
to tighten. Refer to the following connection diagram.

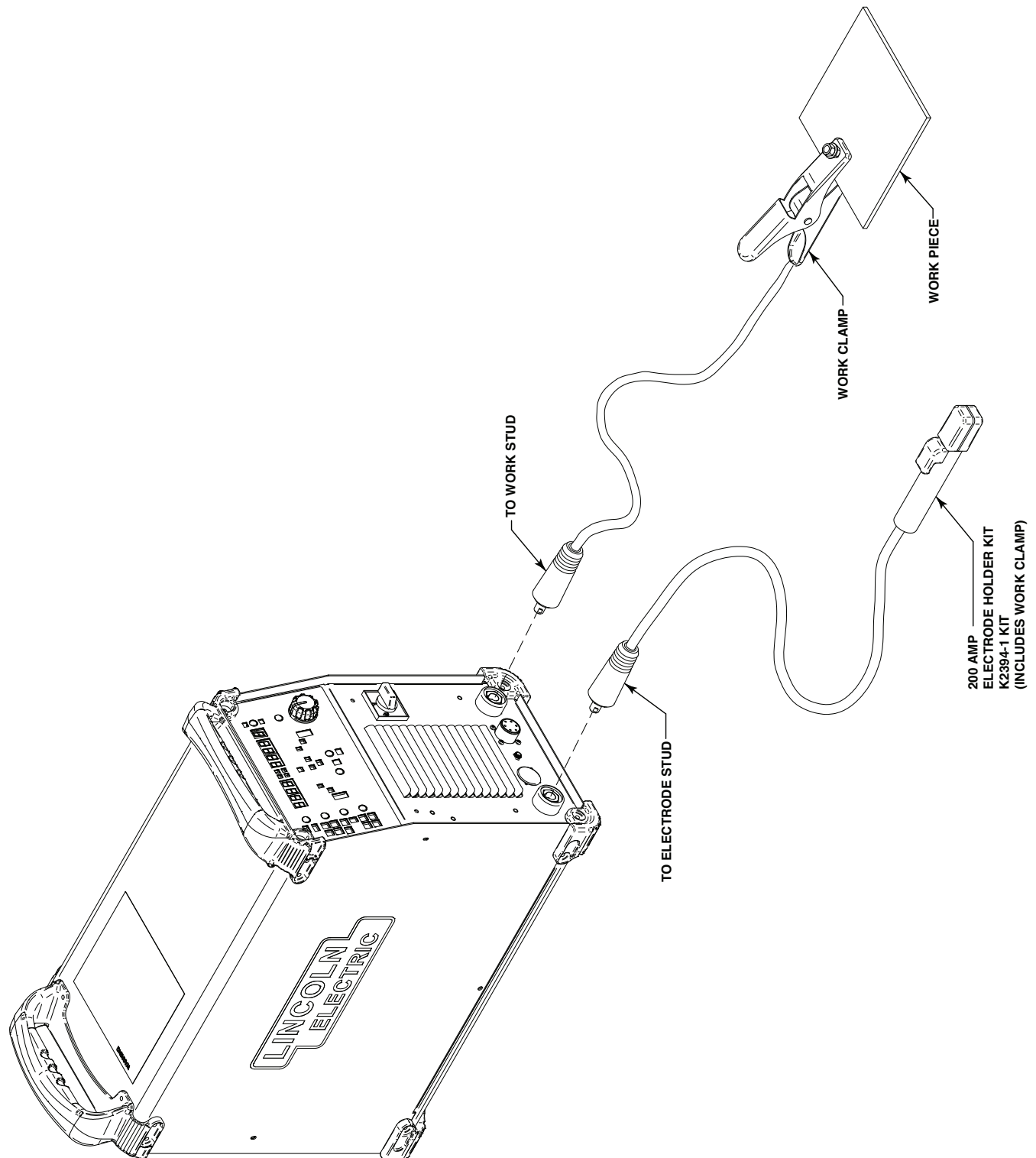

CASE FRONT CONTROLS

(See figure B.1)

1. USER INTERFACE
2. UI CONTROL KNOB – USED TO CONTROL MACHINE OUTPUT SETTING AND TO NAVIGATE THROUGH UI MENUS
3. POWER SWITCH – CONTROLS POWER TO THE ASPECT™ 375
4. ELECTRODE STUD
5. 15VDC SUPPLY
6. 6-PIN REMOTE RECEPTACLE – FOR CONNECTING A FOOT AMP TROL OR OTHER REMOTE CONTROL
7. WORK STUD

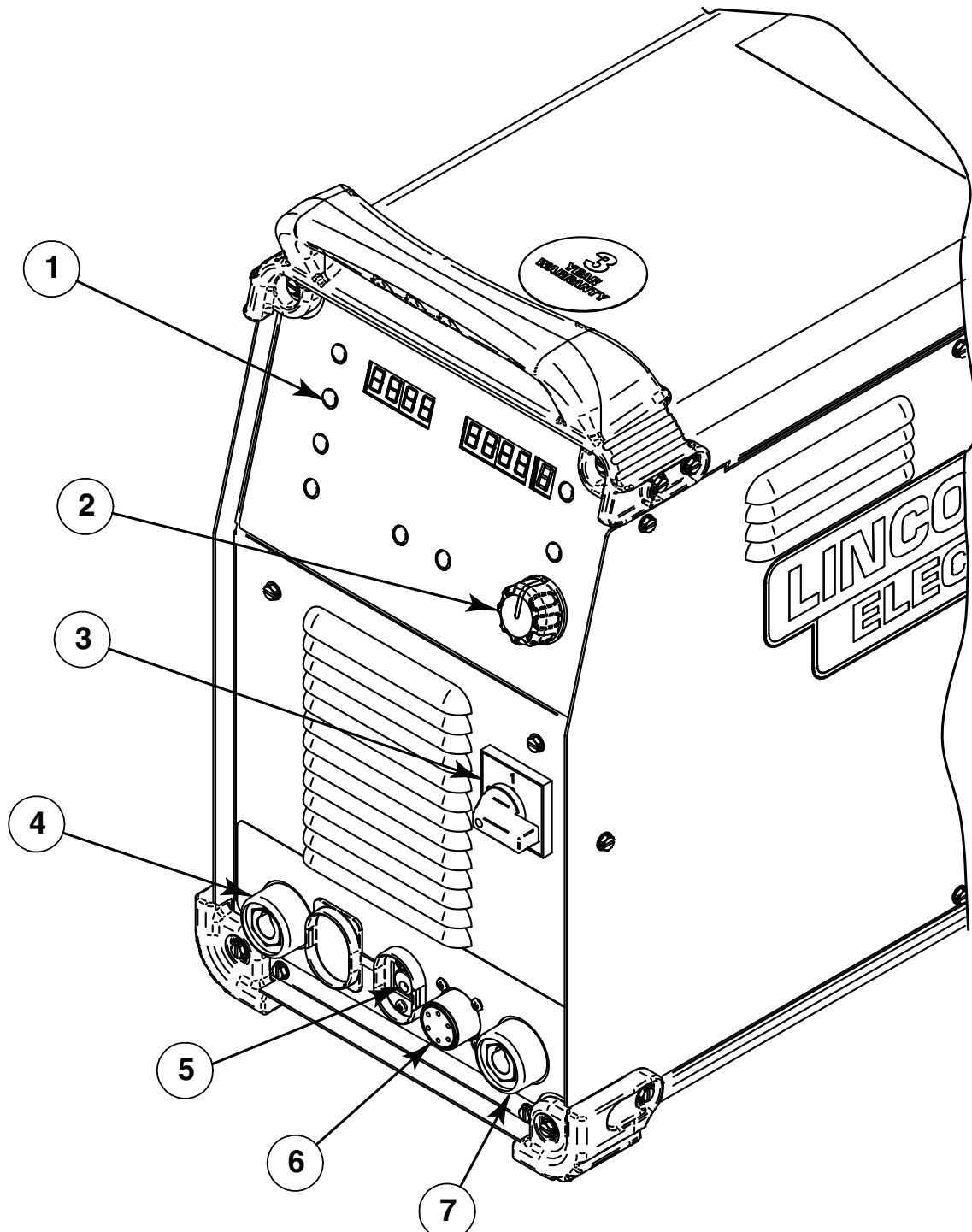
FIGURE B.1







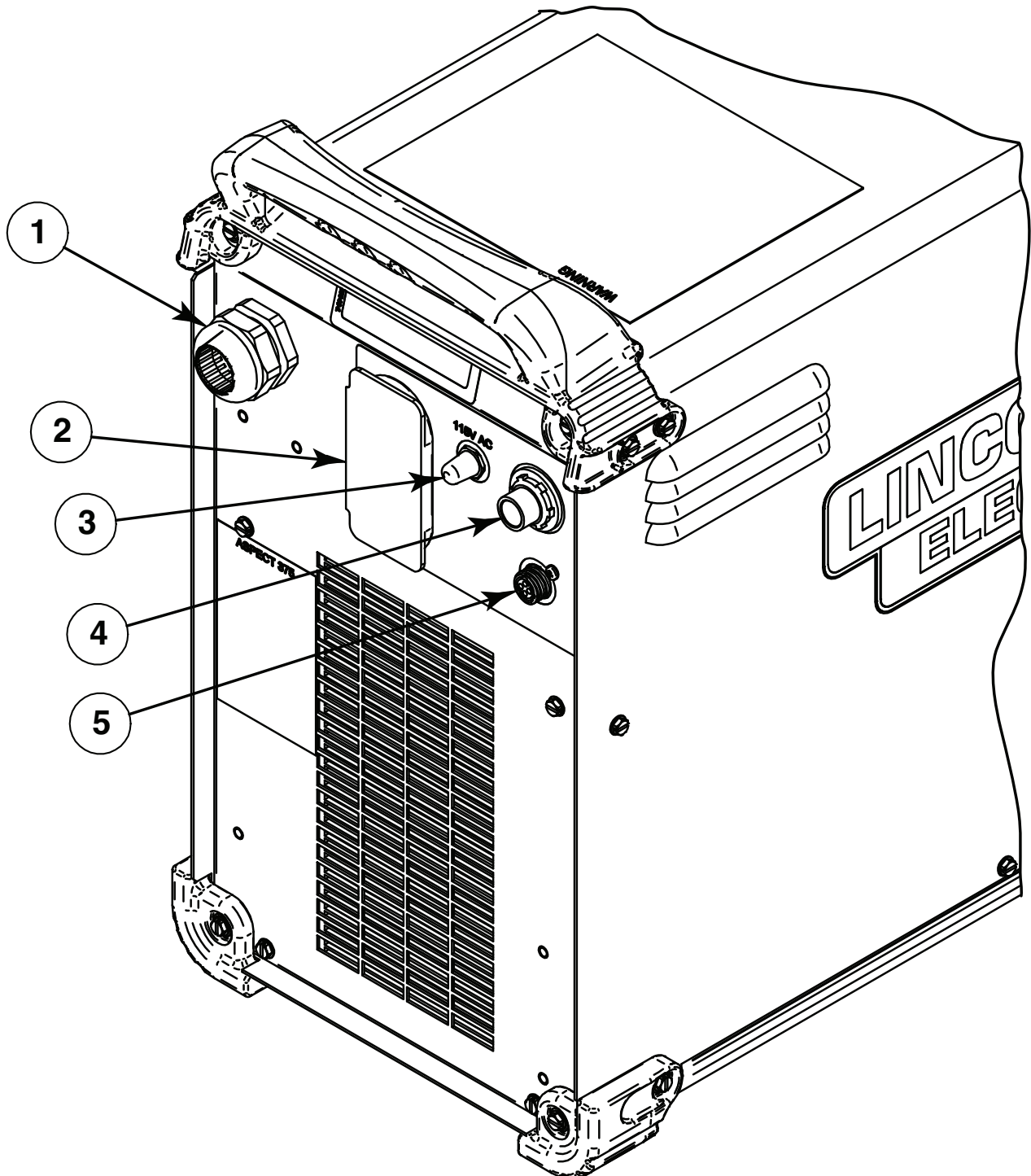







CASE BACK CONTROLS

(See figure B.2)





















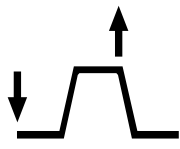

1. INPUT POWER CORD
2. 115 VAC OUTPUT PLUGS
3. 115 VAC CIRCUIT BREAKER (10 A)
4. GAS SOLENOID INPUT
5. 4-PIN WATER COOLER CONNECTION

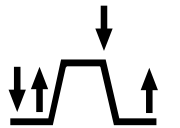
FIGURE B.2

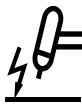
GRAPHIC SYMBOLS THAT APPEAR ON THIS MACHINE OR IN THIS MANUAL

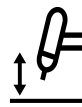
	SAVE		
	ON	U_0	OPEN CIRCUIT VOLTAGE
	OFF	U_1	INPUT VOLTAGE
	HIGH TEMPERATURE	U_2	OUTPUT VOLTAGE
	CIRCUIT BREAKER	I_1	INPUT CURRENT
		I_2	OUTPUT CURRENT
			PROTECTIVE GROUND
	3 PHASE INVERTER		
	INPUT POWER		WARNING OR CAUTION
	THREE PHASE		EXPLOSION
	DIRECT CURRENT		DANGEROUS VOLTAGE
			SHOCK HAZARD

GRAPHIC SYMBOLS THAT APPEAR ON THIS MACHINE OR IN THIS MANUAL

	RECALL		ALTERNATING CURRENT		AC AUTO BALANCE®		GAS CONNECTION
	EXIT MENU		SINGLE PHASE		MENUS		GTAW
	INPUT POWER		PULSE		SEQUENCER		
			WORK LEAD		2 STEP		SMAW
U_p	PEAK VOLTAGE		GAS FLOW		4 STEP		FOOT AMP TROL
U_s	SWITCHED RATED NO LOAD VOLTAGE		AC FREQUENCY		HIGH FREQUENCY TIG		SEE OPERATOR'S MANUAL
%	PERCENT		AC BALANCE		TOUCH START TIG®		VOLTAGE REDUCTION DEVICE
Hz	FREQUENCY		ELECTRODE POSITIVE/ ELECTRODE NEGATIVE		REMOTE		COOLER CONNECTION

USER INTERFACE CONTROLS

FIGURE B.3

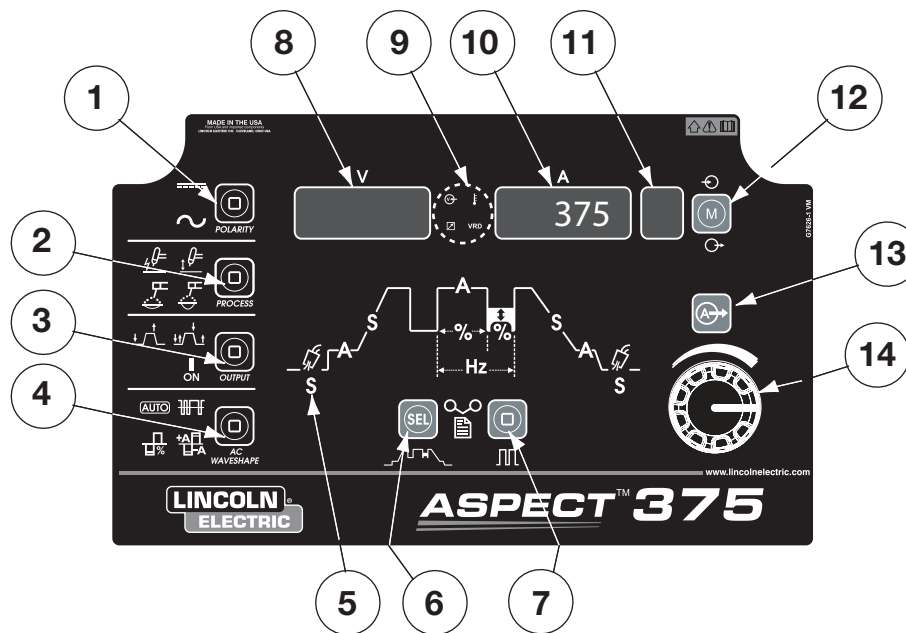

1. Polarity Select – Choose between DC and AC welding.
2. Process Select – Choose between High-Frequency TIG, Touch Start TIG®, Soft Stick (7018 electrodes), or Crisp Stick (6010 electrodes).
3. Output Control – Choose 2-Step, 4-Step, or Output On.
4. AC Waveshape Control – Customize arc performance for AC TIG welding.
5. Sequencer – Allows control of options such as preflow, starting current, slope, etc.
6. Sequencer Control – Push to cycle through the sequencer settings.
7. Pulse Sequencer – Can set percent peak current, pulses-per-second, and percent background current.
8. Voltage Display – Displays the output voltage while welding.
9. Status Lights – Power on, thermal fault, remote, and VRD enable lights.
10. Amperage Display – Displays the current amperage setting.
11. Memory Display – Shows which of the 9 memory modes is currently selected.
12. Memory Selection – Ability to save up to 9 welding procedures and quickly recall them.
13. Exit Menu Button – A quick method to return to amperage adjustment from anywhere in the menus.
14. Control Knob – Used to set output current and to adjust settings.

Polarity

This switch allows the user to set the polarity of the process in use. For DC GTAW welding the output is DCEN and for DC SMAW welding the output is DCEP. (See Figure B.4)

(Changing Polarity to DCEN for SMAW welding is done in the advanced operations menu. See Set-up Menu “SMAW”)

FIGURE B.4

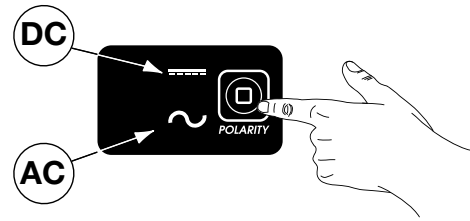

Process

This switch allows the user to set the desired process. (See Figure B.5)

1. High-Frequency TIG
2. Touch Start TIG®
3. Stick – Soft Mode (7018 style electrodes)
4. Stick- Crisp Mode (6010 Style electrodes)

FIGURE B.5

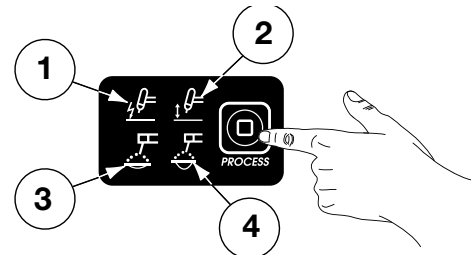

Output Control

This switch allows the operator to set the desired output control method (See Figure B.6). To control the output with 2-step or 4-step, either a remote trigger (arc start switch) or remote trigger with amperage control (foot or hand amptrol) may be used.

FIGURE B.6

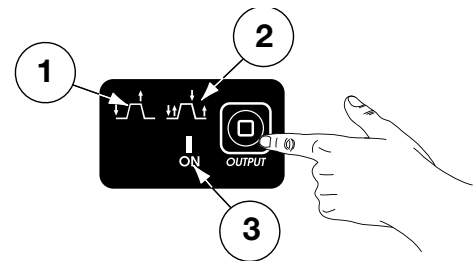

1. **2-Step** (See Figure B.7 and B.8) – With 2-step trigger and a TIG welding mode selected, the following weld sequence will occur. If a standard foot amptrol is connected, it will take control of most sequencer functions, but pre-flow, starting current, finishing current, and post-flow can be defined. With an arc start switch, all sequencer functions should be defined.

FIGURE B.7

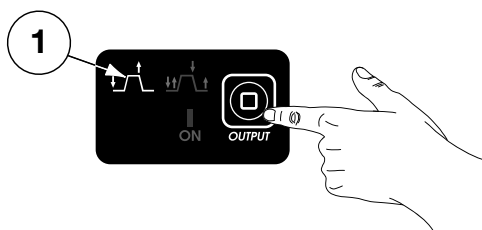

- A. Press and hold the torch trigger to start the sequence. The machine will open the gas valve to start the flow of shielding gas according to the set pre-flow time. After the pre-flow, the output of the machine is turned ON. The arc is started according to the selected weld mode and the specified starting current. After starting, the output current will be increased at a rate dependent on the specified initial slope time, until the operating amperage is reached.

FIGURE B.8

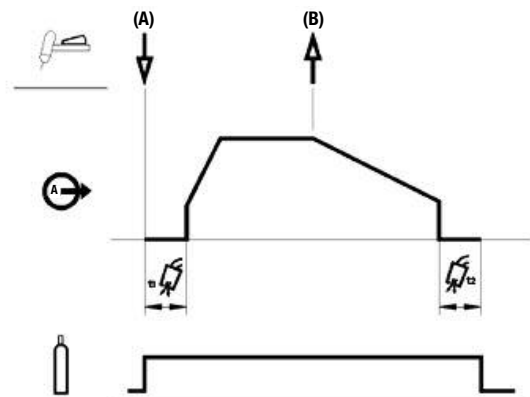

- B. Release the TIG torch trigger to stop welding. The machine will decrease the output current at a rate determined by the specified final slope time, until the finishing current is reached and then the output of the machine is turned OFF.

After the arc is turned OFF, the shielding gas will continue to flow to protect the electrode and weld as specified by the post flow time.

This 2-Step sequence is the factory default setting.

2. **4-Step** (See Figure B.9) – With 4-step trigger mode and a TIG welding mode selected, the following weld sequence will occur. In 4-step, all sequencer functions should be set. If a standard foot amptrol is connected, only its trigger input is functional and the remote output control will be disabled

FIGURE B.9

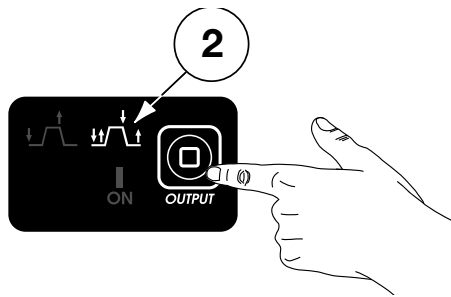

4-Step Functionality

(See Figure B.10)

FIGURE B.10

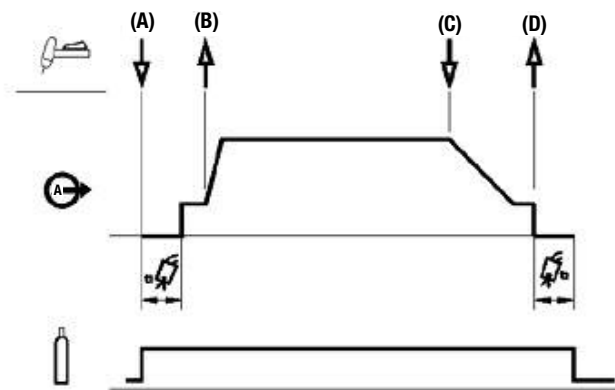

- A. Press and hold the TIG torch trigger to start the sequence. The machine will open the gas valve to start the flow of shielding gas according to the set pre-flow time. After the pre-flow, the output of the machine is turned ON. The arc is started according to the selected weld mode and the specified starting current. The starting current will be held until the torch trigger is released.
- B. Releasing the trigger starts the initial slope function. The output current will be increased at a rate dependent on the specified initial slope time, until the operating amperage is reached.
If the torch trigger is pushed during the upslope time, the arc will immediately shut off and output will be switched OFF.
- C. When the main weld is complete, push and hold the torch trigger to start the final down slope. The machine will decrease the output current at a rate determined by the specified final slope time, until the finishing current is reached.
- D. The finished current will be maintained for as long as the torch trigger is held. Upon releasing the torch trigger, output will be switched OFF and the post flow time will start.

3. **Output On**-This function is designed to be used when TIG welding without the use of an arc-start controller. If "ON" is selected, the machine's output terminals are fully energized. Operator touches tungsten initiating the starting process. Once the tungsten is lifted from the work piece the amperage will proceed to welding amperage. Output "ON" is always illuminated when STICK welding.

(See Figure B.11)

FIGURE B.11

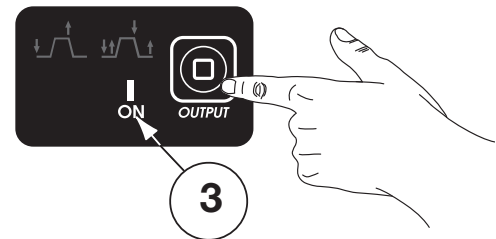

AC Waveshape

This switch allows the operator to customize the arc performance for TIG welding in AC polarity only. Individual descriptions are below.

1. AC AUTO BALANCE®: (Refer to instructions to activate AC AUTO BALANCE® below). While illuminated, the machine determines AC Balance, EP, and EN current values automatically based on user adjusted output amperage setting. The AC frequency may be changed while leaving AUTO ON. In order to make changes to AC Balance, EP, and/or EN current values, AUTO must first be switched OFF. (See Figure B.12 and B.12a)

FIGURE B.12a

Instructions to activate or deactivate the “AC Auto Balance®” setting:

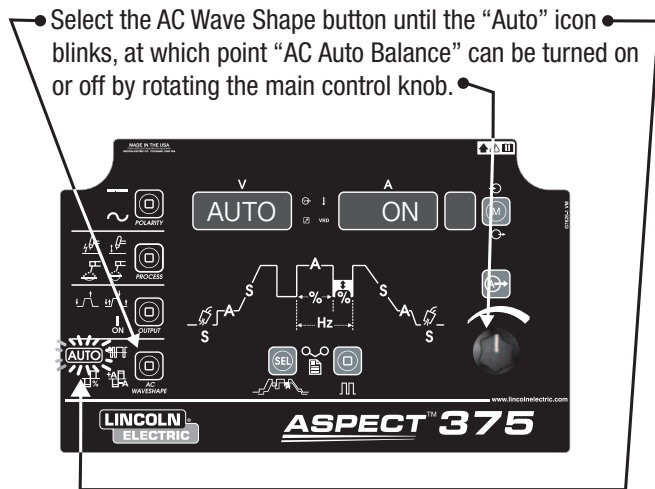

2. AC Frequency: This function controls the frequency of the AC wave in cycles per second. Adjustable from 40-400 Hz. (See Figure B.13)
3. AC Balance: AC balance controls the amount of time, as a percentage, that the polarity is electrode negative. (See Figure B.14) (35-99%)
4. Electrode Positive (EP) / Electrode Negative (EN) Amperage: Allows the operator to adjust the positive and negative amplitude values of the AC wave. (See Figure B.15)

EN, EP and balance settings are all tied to the overall amperage setting of the machine. If the overall welding current is changed, the EN to EP ratio is maintained, but their individual values change with output.

Example: If EN is set to 180 Amps, EP is set to 120 Amps, and Balance is 75%, the displayed welding current will be 165 Amps. If the welding current is now adjusted to 220 Amps, balance will remain at 75%, but EN will change to 240 Amps and EP to 160 Amps (3:2 ratio maintained).

$$A_{AVG} = EN(\%BAL) + EP(1-\%BAL)$$

FIGURE B.12

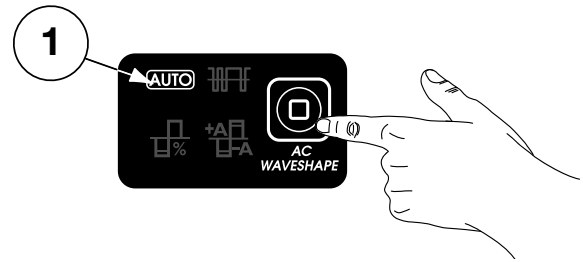

FIGURE B.13

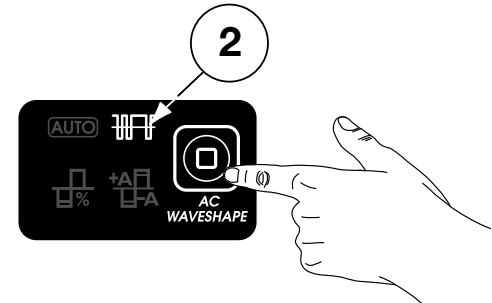

FIGURE B.14

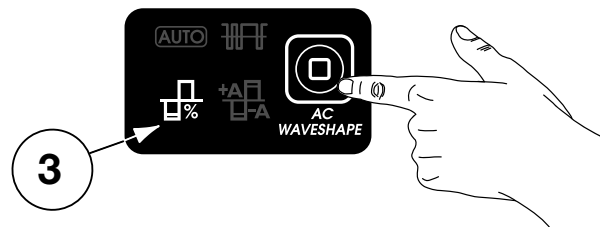
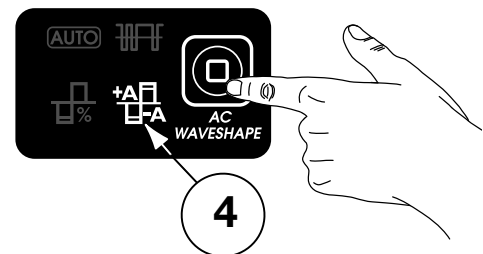

FIGURE B.15



Sequencer Functions

The sequencer allows for customization of the TIG welding operation both in AC & DC- polarities. Pressing the “SEL” button will cycle through the process graph (See figures B.16 and B.17).

1. Pre-Flow: Sets the time in seconds shielding gas will flow prior to arc-start initiation. Default = 0.5 sec (0-25 sec)
2. Starting Current: Sets the starting amperage for the process.
3. Initial Slope: Sets the time in seconds it takes the starting current to reach normal operating amperage. Only functions in 4-Step operation. (0-5 sec)
4. Operating Amperage: Sets max amperage for both 2-Step and 4-Step TIG welding applications.
5. Final Slope: Sets the time in seconds it takes the operating amperage to ramp down to the Finishing current. Only functions in 4-Step. (0 - 25 sec)
6. Finishing Current: Sets the finishing amperage for the process.
7. Post Flow: Sets the time in seconds shielding gas will flow after the arc is terminated. Default = AUTO
Range = (.1 - 60 sec)

FIGURE B.16

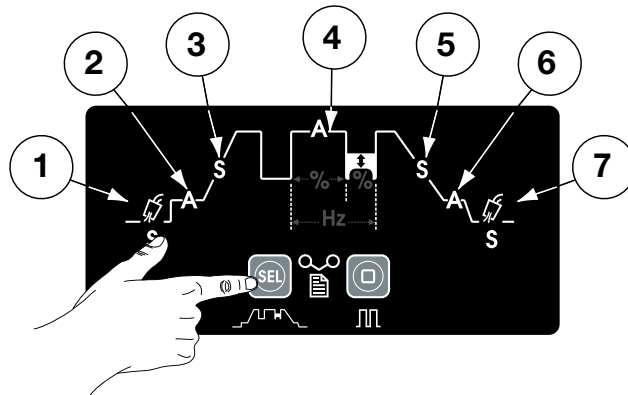

Pulse Sequencer Functions

8. Pulses-Per-Second: Sets the total number of pulse cycles per second of time. (.1 - 2000 in DC) (Maximum AC pulses per second is equal to 1/4 of the AC output frequency)
9. Percent Peak Current: This functions sets the amount of time the pulse waveform spends at the peak current setting. This function is set as a percentage of the total time for the pulse cycle. (5 - 95%)
10. Background Current: Sets the background amperage of the pulse waveform. Background amperage is set as a percentage of the peak current. (10 - 90%)

FIGURE B.17

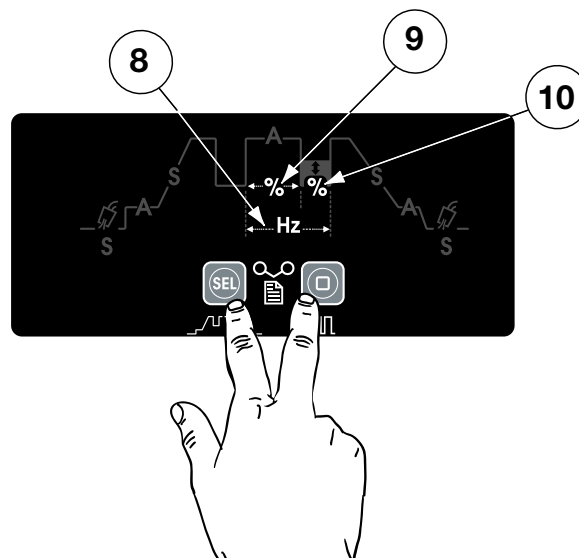

Memory Selection:

The memory function allows the operator to save up to 9 specific welding procedures. This memory switch has two functions:

1. Save memory settings
2. Recall memory settings.

Selecting Memory Functions

Pressing the memory button will allow the user to toggle between “saving” a memory, “recalling” a memory or operating without using a memory setting as seen in Figure B.19.



FIGURE B.18

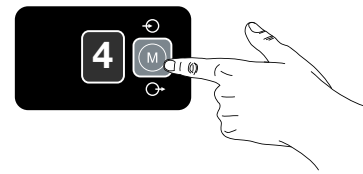

FIGURE B.19

Saving Memory Settings

In order to save process settings into a memory location it is first necessary to press the memory button so that the “memory save” icon is illuminated. Once illuminated, the number on the screen will flash to indicate this number can be changed by turning the control knob, and the voltage and amperage meters will say “MEM SET.” Once the desired memory location has been selected using the control knob, pressing and holding the memory button for 3 seconds will save the settings in that location. During the 3 second hold period the “memory save” icon will flash. After 3 seconds the displayed settings will be saved to memory.

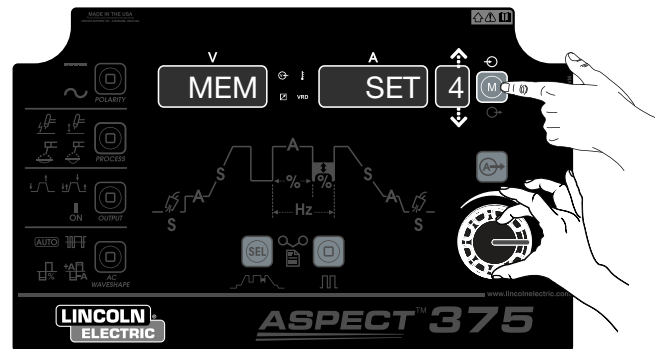
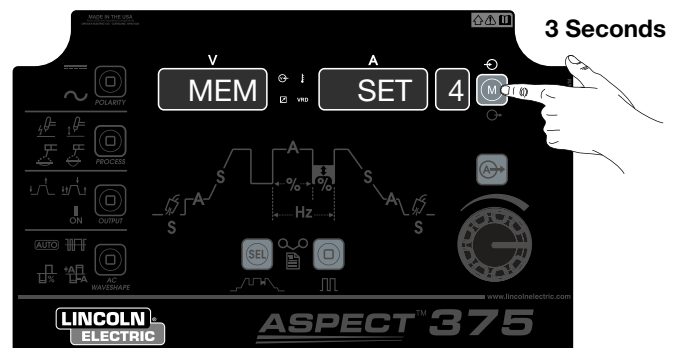

FIGURE B.20

Summary:

1. Press Memory button to highlight “Memory Save” icon
2. Turn Control Knob to select memory location
3. Press and hold memory button for 3 seconds

FIGURE B.21



Memory Recall Settings

(See Figure B.22)

In order to recall process settings it is first necessary to press the memory button so that the “memory recall” icon is illuminated. Once illuminated, the number on the screen will flash to indicate this number can be changed by turning the control knob, and the voltage and amperage meters will say “MEM RECL.” Once the desired memory location has been selected using the control knob, pressing and holding the memory button for 3 seconds will recall the settings from that location. During the 3 second hold period the “memory recall” icon will flash. After 3 seconds the recalled settings will be displayed.

FIGURE B.22

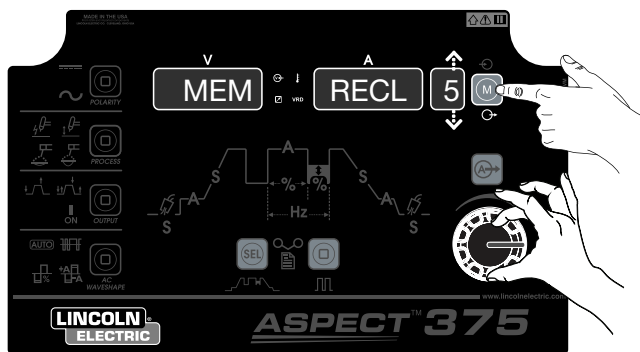

Summary:

(See Figure B.23)

1. Press Memory button to highlight “Memory Recall” icon
2. Turn Control Knob to select memory location
3. Press and hold memory button for 3 seconds

FIGURE B.23

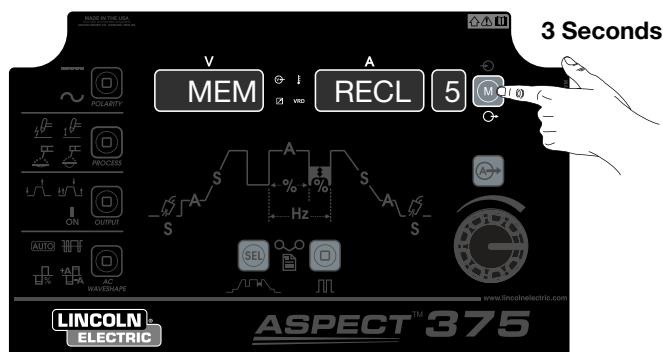

Status Lights:

(See Figure B.24)

There are 4 status lights located between the voltage and amperage displays. These LEDs illuminate to display the following:



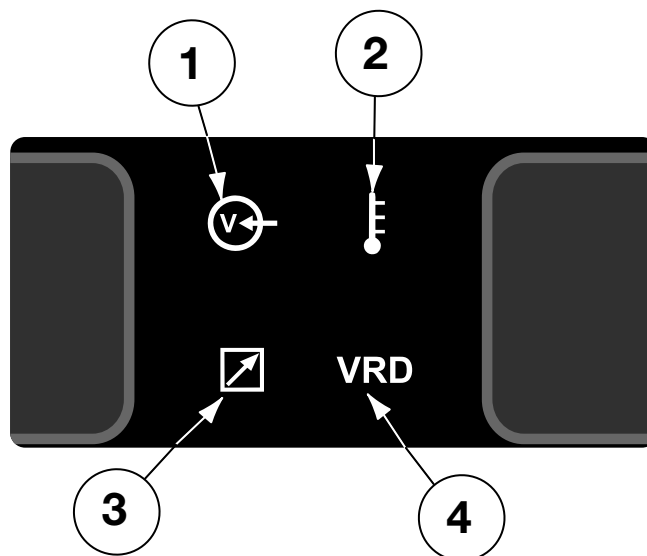

1. **Power on** – This light indicates that power has been applied to the machine and it is ready to weld. A blinking light indicates that the start up sequence is in process. When the light turns fully ON, the machine is ready to weld.
2. **Thermal Fault** – The thermal light will turn on if the machine has overheated. Welding may continue after the machine has cooled and the light switches off.
3. **Remote** – When a remote output control is connected to the 6 pin connector on the front of the machine, this LED will turn on.
4. **VRD** – When operating in VRD Mode (Voltage Reduction Device) this LED will light up when the output voltage is below 12 Volts. VRD may be turned ON / OFF in Setup Menu “SYS.”

FIGURE B.24



Hold Select button for 5 seconds to enter Menu "GTAW."



Setup Menu "GTAW"			TIG Settings
Display	Item	Choices	Description
DIA	Tungsten Diameter	AUTO	Specify your tungsten size for better arc initiation. AUTO (Intellistart™) automatically manages arc starting conditions to match adjusted amperage setting. Selecting ADV will allow manual adjustment of starting parameters.
		020	
		040	
		1/16	
		3/32 (Default)	
		1/8	
		5/32	
		ADV	
The following settings are only available if DIA is set to ADV			
SCRT	Starting Current	2-200 Amps	Amplitude of initial starting pulse
STME	Starting Time	1-100 ms	Time of initial arc start pulse (1 cycle)
SSLP	Starting Slope	0-250 ms	How fast operating current is reached
PCRT	Preset Current Minimum	2-25 Amps	Minimum current machine will output
POL	Starting Polarity	EN	Choose whether the starting polarity is negative or positive.
		EP	
WAVE	Waveform Shape	Soft Square  (Default)	Choose which waveform you would like to use. - Increased puddle control.
		Sine 	= Soft sounding arc.
		Square 	- Faster travel speeds.
		Triangular 	- Reduce heat input for thinner materials. Also provides for better cleaning for anodized applications.
2RST	Advanced Trigger	ON	Switch ON to enable 2 Step trigger with restart. See Appendix for more information.
		OFF	
4RST		ON	Switch ON to enable 4 Step trigger with restart. See Appendix for more information.
		OFF	
BILV		ON	Switch ON to enable Bi-level trigger. See Appendix for more information.
		OFF	
SPOT	Spot Timer	OFF - 100 s	Specify your spot weld time. Default = OFF.

Hold Pulse button for 5 seconds to enter Menu "SMAW."

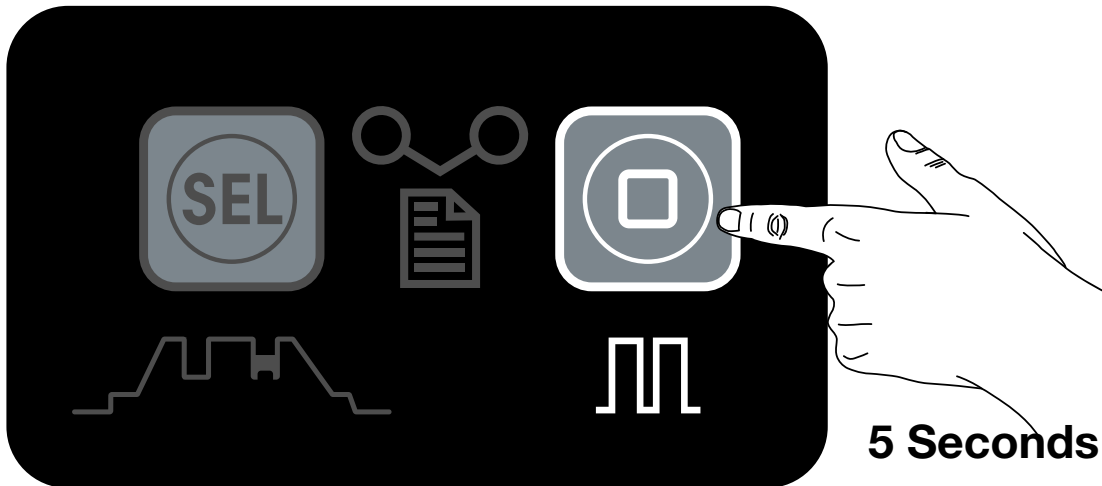

Setup Menu "SMAW"			Stick Settings
Display	Item	Choices	Description
FRCE	Arc Force	0-75 for soft stick 75-200 for crisp stick	Specify your Arc Force setting
HSTR	Hot Start	0-75 for soft stick 50-200 for crisp stick	Specify your Hot Start setting
POL	Stick Polarity	DC+	Change your welding polarity. Default setting is DC+.
		DC-	

Hold both Select and Pulse buttons for 5 seconds to enter Menu "SYS."

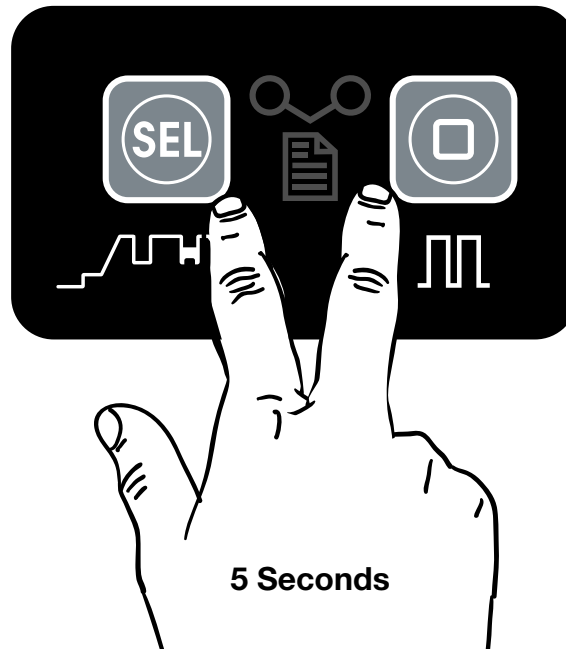

Setup Menu "SYS"			System Settings
Display	Item	Choices	Description
UNIT	Units	INCH MM	Change between imperial and metric units.
VRD	Voltage Reduction Device	ON OFF	Turn ON to enable VRD and limit machine OCV to 12 Volts.
LED	LED Brightness	LOW MED HIGH	Adjusts the intensity of the display LEDs.
COOL	Cooler Control	AUTO ON	On AUTO, the cooler turns on and off as needed. ON forces it to run continuously.
DIAG	Diagnostics	-	Enter diagnostics mode.
CTRL	Control Board Software Version	-	Displays current control board software version.
UI	User Interface Board Software Version	-	Displays current UI board software version.
ERR	Error Messages	-	Displays error messages. (See Trouble Shooting Section.)
RSET	Reset to Default	-	Resets settings to factory default.

Appendix

A.1 Volt and Amp meter display while welding and idle.

While welding, the machine will show actual voltage and amperage on the meters. When the welding arc is extinguished, the meters will display (and flash) the final voltage and amperage of that weld for 5 seconds. When the machine is idle, and not in pulse mode, the voltage meter will display 4 dash marks until welding is initiated.

Figure B.25

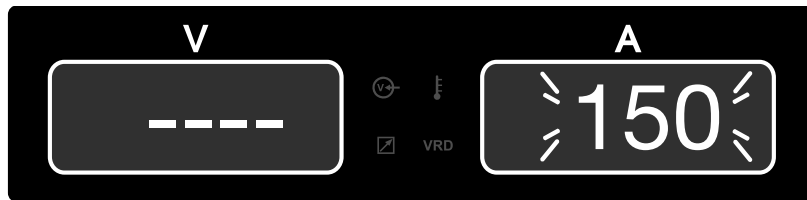

A.2 Green Mode (Show the V and A displays with GRN MODE)

Green mode is a feature that puts the machine in a standby condition after 10 minutes of inactivity.

- Output is Disabled.
- Fans Change to a Low Speed.
- LEDs Switch Off – Only the Power ON LED Remains Lit.
- Display will flash GRN MODE every several seconds.

This feature will reduce the amount of dust and dirt that is drawn into the machine and will lower the machines power consumption.

To exit Green Mode, simply press the TIG remote trigger or any button on the front of the machine.

NOTE: If a Cool Arc® machine is connected to the Aspect™ 375, entering Green Mode will stop the coolant flow. To resume coolant flow, Green Mode must first be exited.

A.3 2-Step Trigger with Restart Sequence

2-Step trigger with restart can be enabled in setup menu “GTAW” by switching 2RST to ON. If 2RST is ON, a TIG mode is selected, and 2-step is selected on the output section of the machine, the following sequence will occur.

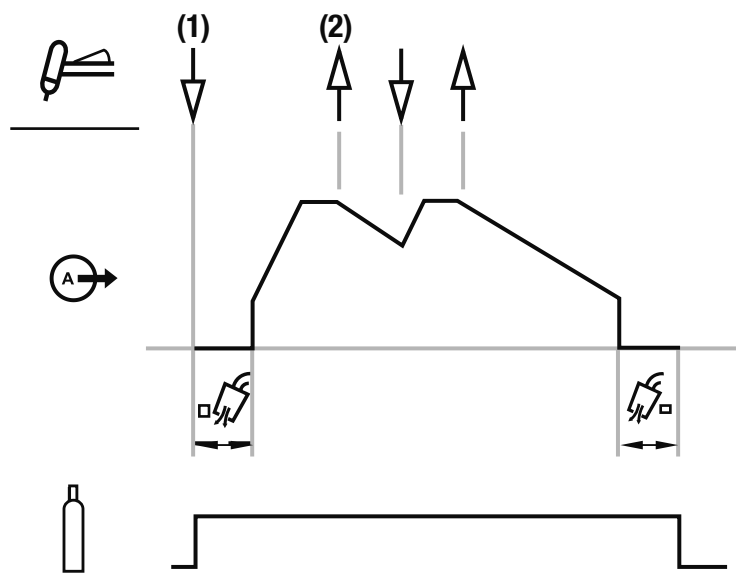

This sequence is the same as 2-step, except when the switch is pressed while in final slope the welding current will ramp up again and resume. This process can be repeated as many times as necessary. When finished welding, simply release the trigger and allow the finishing current to end and the output to switch OFF followed by the post flow time.

A.4 4-Step Trigger with Restart Sequence

4-Step trigger with restart can be enabled in setup menu “GTAW” by switching 4RST to ON. If 4RST is ON, a TIG mode is selected, and 4-step is selected on the output section of the machine, the following sequence will occur.

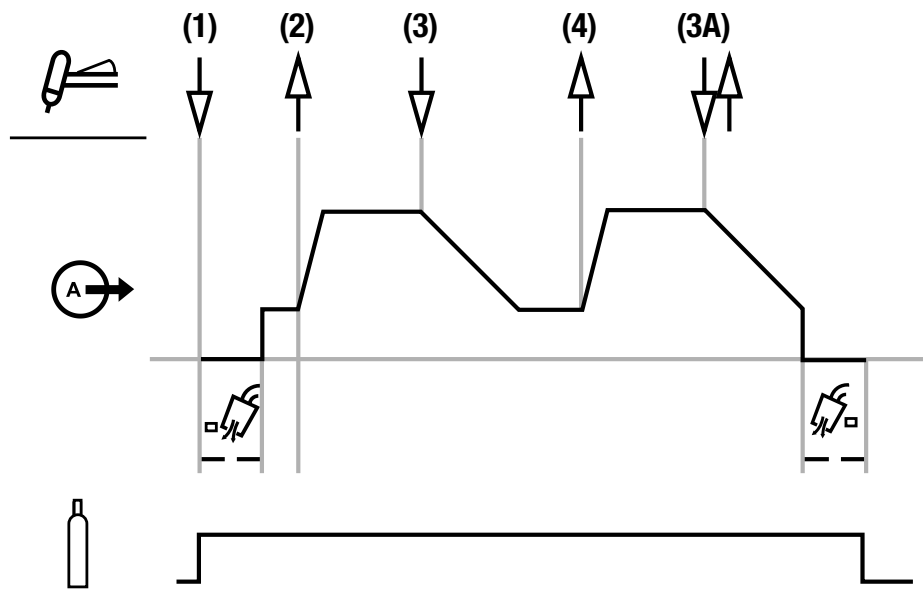

This sequence is the same as 4-step, except when the switch is released during the finishing current, welding current will ramp up again to the operating amperage. This process can be repeated as many times as necessary. When welding is finished, quickly press and release the trigger to start the final slope, which will be followed by the finishing current at which point output is switched OFF, and the post flow will initiate.

A.5 Bi-Level Trigger Sequence

Bi-Level Trigger Sequence Bi-level trigger can be enabled in setup menu “GTAW” by switching BILV to ON. If BILV is ON, a TIG mode is selected, and 4-step is selected on the output section of the machine, the bi-level sequence will be followed. Bi-level follows the same sequence as 4-step but allows switching between operating amperage and a background current, A2. With Bi-level enabled, press the SEL button until the left display shows A2. Turning the control knob will allow the A2 level to be set as a percent of the operating current.

While welding at the set operating current, quickly press and release the trigger to switch to the A2 background current level. Quickly pressing and releasing the trigger again will switch the output back to the set operating current. Each time this trigger action is repeated the current level will switch between the two levels. When the main weld is complete, press and hold the trigger to start the final slope and finishing current. Release the switch to switch the output OFF and begin the post flow time.

GENERAL OPTIONS / ACCESSORIES

Field Installed

K870 - Foot Amptrol™ for TIG welding. The foot Amptrol energizes the output and controls the output remotely. The Foot Amptrol™ connects directly to the 6-pin remote control connector.

K963-3 - Hand Amptrol™ for TIG welding. The Hand Amptrol™ energizes the output and controls the output remotely. The Hand Amptrol™ connects directly to the 6-pin remote control connector.

K814 - Arc Start Switch - Energizes the output for TIG welding if remote output control of the amperage is not desired. It allows on/off TIG welding at the amperage set by the Current Control on the control panel.

K3950-1 - Cool-Arc® 47 Water Cooler- Attaches underneath the ASPECT™ 375 and electrically connects to the ASPECT™ 375. This smart cooler runs only when needed and shuts off welding if coolant flow is interrupted.

K3949-1 TIG Inverter Cart- Holds the ASPECT™ 375, the Cool Arc® 47 and all accessories. Features low lift bottle loader and drawer for convenient storage.

K918-1 Zippered cable cover, 12.5 ft. (3.8 m)- to protect torch cables in high abrasion applications.

K918-2 Zippered cable cover, 25.0 ft. (7.6 m)- to protect torch cables in high abrasion applications.

Regulator with Flow Gauge and Hose Kit (3100211)

K2266-1 – TIG-Mate™ 17 Air Cooled TIG Torch Starter Pack.

One complete easy-to-order kit packaged in its own portable carrying case. Includes: PTA-17 torch, parts kit, Harris flowmeter/regulator, 10 ft. gas hose, Twist-Mate™ adapter, work clamp and cable.

Magnum® TIG Torches – The following standard Magnum® TIG torches may be used with the ASPECT™ 375 for Lincoln's full line of TIG torches including flex head models consult publication E12.150.

- K1782-1 PTA-17 12.5 ft.(3.8m) Air-Cooled 150A
- K1782-3 PTA-17 25 ft.(7.6m) Air-Cooled 150A
- K1783-1 PTA-26 12.5 ft.(3.8m) Air-Cooled 200A
- K1783-3 PTA-26 25 ft.(7.6m) Air-Cooled 200A

K4843-18F-2 Caliber PTW-18 Water Cooled Torch.

K1622-5 Twist-Mate™ Adapter - Adapter needed for K4168-2 and K1784-2 torches

NOTE: Each torch requires a Twist-Mate™ Adapter, collets, collet bodies, and nozzles and are not included and must be ordered separately.

KP509- Magnum® parts kit for PTW-18 and PTA-26 series torches.

KP4760-HD Parts Kit for Caliber PTW-18 Torch

K1803-3 - Work Lead Clamp with Twist-Mate™ plug, 15ft.(4.6m).

KP4159-1 Low Conductivity Coolant (1 Gal.)

K1622-3 Twist Mate Adapter for PTA-26 TIG Torch

K1622-1 Twist Mate Adapter for PTA-17 TIG Torch

SAFETY PRECAUTIONS

WARNING



ELECTRIC SHOCK can kill.

- **Only qualified personnel should perform this maintenance.**
- **Turn the input power OFF at the disconnect switch or fuse box before working on this equipment.**
- **Do not touch electrically hot parts.**

WARNING

To avoid receiving a high frequency shock, keep the TIG torch and cables in good condition.

ROUTINE AND PERIODIC MAINTENANCE

Very little routine maintenance is necessary to keep your ASPECT™ 375 running in top condition. No specific schedule can be set for performing the following items; factors such as hours of usage and machine environment should be considered when establishing a maintenance schedule.

- Periodically blow out dust and dirt which may accumulate within the welder using an air stream.
- Inspect welder output and control cables for fraying, cuts, and bare spots.
- The fan motor has sealed ball bearings which require no maintenance.

OVERLOAD PROTECTION

FAN-AS-NEEDED (F.A.N.)

The ASPECT™ 375 has the F.A.N. circuit feature, which means the cooling fan will operate only as needed to assure proper machine cooling. This helps reduce the amount of dust and dirt drawn into the machine with the cooling air. The cooling fan will operate at lower speeds when the machine power is initially turned on or at idle, and continuously while the yellow Thermal Shutdown Light is lit (see Thermostatic Protection).

THERMOSTATIC PROTECTION

This welder has thermostatic protection from excessive duty cycles, overloads, loss of cooling, and excessive ambient temperatures. When the welder is subjected to an overload, or inadequate cooling, the primary coil thermostat and/or secondary coil thermostat will open. This condition will be indicated by the illumination of the yellow Thermal Shutdown Light on the front panel (see Item 2 in Figure B.24 Operation Section). The fan will continue to run to cool the power source. Postflow occurs when TIG welding is shut down, but no welding is possible until the machine is allowed to cool and the yellow Thermal Shutdown Light goes out.

NO ARC PROTECTION

The machine outputs (Background / OCV, gas and HF) will be shutdown, if the trigger is closed without welding for 15 seconds to protect the Background resistor from overheating with F.A.N. cooling off, as well as to conserve on gas waste.

AUXILIARY POWER CIRCUIT BREAKER

This machine includes a 10 amp circuit breaker, located on the opposite side of the upper case back, for protection of the 115 Vac receptacle.

HOW TO USE TROUBLESHOOTING GUIDE



WARNING

Service and Repair should only be performed by Lincoln Electric Factory Trained Personnel. Unauthorized repairs performed on this equipment may result in danger to the technician and machine operator and will invalidate your factory warranty. For your safety and to avoid Electrical Shock, please observe all safety notes and precautions detailed throughout this manual.

This Troubleshooting Guide is provided to help you locate and repair possible machine malfunctions. Simply follow the three-step procedure listed below.

Step 1. LOCATE PROBLEM (SYMPTOM).

Look under the column labeled "PROBLEM (SYMPTOMS)." This column describes possible symptoms that the machine may exhibit. Find the listing that best describes the symptom that the machine is exhibiting.

Step 2. POSSIBLE CAUSE.

The second column labeled "POSSIBLE CAUSE" lists the obvious external possibilities that may contribute to the machine symptom.

Step 3. RECOMMENDED COURSE OF ACTION

This column provides a course of action for the Possible Cause, generally it states to contact your local Lincoln Authorized Field Service Facility.

If you do not understand or are unable to perform the Recommended Course of Action safely, contact your local Lincoln Authorized Field Service Facility.



CAUTION

If for any reason you do not understand the test procedures or are unable to perform the tests/repairs safely, contact your **Local Lincoln Authorized Field Service Facility** for technical troubleshooting assistance before you proceed.

Observe all Safety Guidelines detailed throughout this manual

ERROR CODE LIST

CODE	DESCRIPTION	POSSIBLE CAUSE	CORRECTIVE ACTION
01	Low input	Input voltage is lower than 200V or drops below 200V under load	Check input voltage, cable size, and fuse size.
02	High input	Input voltage is higher than 600V or spikes above 600V under load	Check input voltage.
05	AC switch overload	Output overload	Cycle power to clear the fault. If problem persists, contact Lincoln Authorized Service Facility.
06	Inverter Under Voltage Lock Out	Internal +15V supply is too low	Cycle power to clear the fault. If problem persists, contact Lincoln Authorized Service Facility.
11	Water Cooler Fault	Cooler is not plugged in to 115V receptacle, insufficient coolant in cooler, TIG Torch is undersized (amperage capacity) for application, blown fuse, or faulty flow sensor inside cooler.	<p>Initial Corrective Measures: Check Cooler Connections, Fill Cooler with additional Low Conductivity Coolant (KP4159-1), Replace with higher amperage capacity TIG Torch. Replace 3A fuse. Depress Flow Sensor Off button to remove error code.</p> <p>Secondary Corrective Measures: Service cooler</p>



CAUTION

If for any reason you do not understand the test procedures or are unable to perform the tests/repairs safely, contact your **Local Lincoln Authorized Field Service Facility** for technical troubleshooting assistance before you proceed.

Observe all Safety Guidelines detailed throughout this manual

TIG WELDING ISSUES

SYMPTOMS	POSSIBLE CAUSE	RECOMMENDED COURSE OF ACTION
Poor starting	Poor work clamp connection	Check and secure work connection
	Wrong “DIA” setting	Access “GTAW” menu (see operation section) and set DIA for Intellistart™ “AUTO” or proper Tungsten size
	Start current is too low	Increase start current
Black area along weld bead	Oily or organic contamination on work piece	Clean work piece
	Tungsten electrode may be contaminated	Grind to clean electrode
	Leaks in gas line or torch connection	Check connection
	Gas tank is near empty	Replace the gas tank
Output quits momentarily; gas flow and hi-freq are also interrupted	May be caused by hi-freq interference	Check for proper machine ground connection; surrounding machines that generate hi-freq also should be grounded properly
	Faulty Components, PC Boards or Connections	Contact your local Lincoln Authorized Field Service Facility.
Arc flutters	Pulser may be turned on inadvertently	Turn Pulser off
	Electrode may be too large for current setting	Use smaller Tungsten
	Insufficient gas shielding	Adjust flow rate
	Contaminated gas or leaks in gas line, torch, or connections	Check gas line & connections



CAUTION

If for any reason you do not understand the test procedures or are unable to perform the tests/repairs safely, contact your **Local Lincoln Authorized Field Service Facility** for technical troubleshooting assistance before you proceed.

Observe all Safety Guidelines detailed throughout this manual

SYMPTOMS	POSSIBLE CAUSE	RECOMMENDED COURSE OF ACTION
Insufficient cleaning	Wave shape settings may not suit application	Set for manual balance and increase EP or reduce balance percentage
Insufficient penetration	Wave shape settings may not suit application	Set for manual balance and increase EN or balance percentage
Unstable	Wrong Wave form setting	Access “GTAW” menu (see operation section) and change “WAVE” setting to “SQRE” or “SOFT”
	AC frequency may not suit application	Adjust AC frequency
Tail-out current too high	Finishing current may be set too high	Reduce Finishing current
Output shut off during welding	Spot Timer may be turned on inadvertently	Access “GTAW” menu (see operation section) and change “SPOT” to “OFF”
	Faulty Components, PC Boards or Connections	Contact your local Lincoln Authorized Field Service Facility.



CAUTION

If for any reason you do not understand the test procedures or are unable to perform the tests/repairs safely, contact your **Local Lincoln Authorized Field Service Facility** for technical troubleshooting assistance before you proceed.

Observe all Safety Guidelines detailed throughout this manual

STICK WELDING ISSUES

SYMPTOMS	POSSIBLE CAUSE	RECOMMENDED COURSE OF ACTION
Poor starting	Hot start may be set too low	Access "SMAW" menu (see operation section) and increase "HSTR" setting
	Poor work clamp connection	Check and secure work connection
Stick electrode "blasts off" when arc is struck	Current may be set too high for electrode size	Adjust current
	Hot start set too high	Access "SMAW" menu (see operation section) and reduce "HSTR" setting
Electrode "sticks" in weld puddle	Current may be set too low for electrode size	Adjust current
	Arc force set too low	Access "SMAW" menu (see operation section) and increase "FRCE" setting
Insufficient penetration	Wrong Process setting	Set Process for Crisp Stick



CAUTION

If for any reason you do not understand the test procedures or are unable to perform the tests/repairs safely, contact your **Local Lincoln Authorized Field Service Facility** for technical troubleshooting assistance before you proceed.

Observe all Safety Guidelines detailed throughout this manual

START-UP ISSUES

SYMPTOMS	POSSIBLE CAUSE	RECOMMENDED COURSE OF ACTION
Green Input indicator light does not stop blinking	Trigger or hand/foot Amptrol may be accidentally closed during start up	Turn machine off, open trigger or Amptrol, then turn machine on
	Input voltage is too high or too low	Check input voltage (208V to 575V)
	Faulty PC Boards or connections	Contact your local Lincoln Authorized Field Service Facility.
Meters don't light up	Losing input to machine	Check input fuses and connection
	Faulty Components, PC Boards or Connections	Contact your local Lincoln Authorized Field Service Facility.

PRESET ISSUES

SYMPTOMS	POSSIBLE CAUSE	RECOMMENDED COURSE OF ACTION
Operating Amperage changes after changing EP or EN in AC Waveshape	This is normal, the operating Amperage is calculated based on EP, EN, and Balance settings	Adjust to desired Amperage
Operating Amperage can't be set for 2A	"DIA" setting in "GTA W" menu is set for specific size, e.g. 3/32"	Set for "AUTO" or smaller size diameter
Operating Amperage can't be set for 375A	EP and EN are set too extreme	Set for Auto balance or reduce EP, EN

⚠ CAUTION

If for any reason you do not understand the test procedures or are unable to perform the tests/repairs safely, contact your **Local Lincoln Authorized Field Service Facility** for technical troubleshooting assistance before you proceed.

Observe all Safety Guidelines detailed throughout this manual

OPEN CIRCUIT VOLTAGE (OCV) ISSUES

Note: Do not connect a meter to machine output terminals to measure voltage in Tig mode as hi-freq produced by machine may damage meter. When trigger is closed in Tig mode, machine displays OCV on left meter for approximately 3 seconds then output will turn off if a weld is not made. Machine does not display OCV in Stick mode even though the output is always on.

SYMPTOMS	POSSIBLE CAUSE	RECOMMENDED COURSE OF ACTION
OCV is below 10V in Tig mode	Preflow time set too long	Set for typical 0.5 second preflow
	Faulty PC Boards or connections	Contact your local Lincoln Authorized Field Service Facility.
OCV is below 80V in Tig mode	Faulty Components, PC Boards or Connections	Contact your local Lincoln Authorized Field Service Facility.

OUTPUT PROBLEMS

SYMPTOMS	POSSIBLE CAUSE	RECOMMENDED COURSE OF ACTION
Thermal light turns on	Welding application exceeds rated duty cycle	Reduce duty cycle
	Air intake & exhaust louvers may be blocked	Maintain sufficient clearance around machine
	Dirt and dust may have clogged the cooling channel inside machine	Blow out machine with clean, dry low pressure air
	Faulty fans or connections	Contact your local Lincoln Authorized Field Service Facility.
	Faulty Components, PCB or Connections	Contact your local Lincoln Authorized Field Service Facility.
Output o.k. in Stick but no output in Tig	No gas & no hi-freq	Faulty trigger or hand/foot Amptrol or connection
	Gas & hi-freq o.k.	Faulty PC Boards or connections
No output in both Stick and Tig	Faulty PC Boards or connections	Contact your local Lincoln Authorized Field Service Facility.

⚠ CAUTION

If for any reason you do not understand the test procedures or are unable to perform the tests/repairs safely, contact your **Local Lincoln Authorized Field Service Facility** for technical troubleshooting assistance before you proceed.

Observe all Safety Guidelines detailed throughout this manual

REMOTE CONTROL ISSUES

SYMPTOMS	POSSIBLE CAUSE	RECOMMENDED COURSE OF ACTION
Hand/foot Amprol has no control	Machine set for 4-step trigger	Set for 2-step trigger
	Start current set too high	Reduce Start current
	Faulty Amprol	Check Amprol
	Faulty Components, PCB or Connections	Contact your local Lincoln Authorized Field Service Facility.

GAS ISSUES

SYMPTOMS	POSSIBLE CAUSE	RECOMMENDED COURSE OF ACTION
Gas will not turn off	Postflow time set too long	Adjust postflow time
	Defective gas solenoid	Check gas solenoid
	Faulty PC Boards or connections	Contact your local Lincoln Authorized Field Service Facility.
No gas	Faulty gas solenoid or connection	Contact your local Lincoln Authorized Field Service Facility.
	Faulty PC Boards or connections	Contact your local Lincoln Authorized Field Service Facility.

⚠ CAUTION

If for any reason you do not understand the test procedures or are unable to perform the tests/repairs safely, contact your **Local Lincoln Authorized Field Service Facility** for technical troubleshooting assistance before you proceed.

Observe all Safety Guidelines detailed throughout this manual

HI-FREQUENCY ISSUES

SYMPTOMS	POSSIBLE CAUSE	RECOMMENDED COURSE OF ACTION
No hi-freq	Wrong Process setting	Verify Process is set for hi-freq Tig
	Preflow time set too long	Set for typical 0.5 second preflow time
	Faulty PC Boards or connections	Contact your local Lincoln Authorized Field Service Facility.
Hi-freq does not initiate an arc	Insufficient gas flow	Check gas flow
	Poor work clamp connection	Check & secure work clamp
	Contaminated Tungsten	Grind to clean Tungsten
	Faulty torch	Check Tig torch & insulation
	Faulty PC Boards or connections	Contact your local Lincoln Authorized Field Service Facility.

CAUTION

If for any reason you do not understand the test procedures or are unable to perform the tests/repairs safely, contact your **Local Lincoln Authorized Field Service Facility** for technical troubleshooting assistance before you proceed.

Observe all Safety Guidelines detailed throughout this manual

115V AUXILIARY OUTPUT ISSUES

SYMPTOMS	POSSIBLE CAUSE	RECOMMENDED COURSE OF ACTION
No output	Overload trips 115V circuit breaker	Remove load & reset breaker
	Overload trips internal thermostat	Remove load & wait for thermostat to reset
	Faulty receptacle or connection	Check receptacle and connection
	Faulty PC Boards or connections	Contact your local Lincoln Authorized Field Service Facility

WATER COOLER ISSUES

NOTE: If cooler control cable is connected to or disconnected from machine when machine is already turned on, machine must be recycled by turning off and then on so that cooler is recognized by machine; failure to do this may damage Tig torch when welding

SYMPTOMS	POSSIBLE CAUSE	RECOMMENDED COURSE OF ACTION
Indicator light on cooler does not turn on	Cooler is not plugged in	Plug cooler to 115V receptacle
	No 115V output	Refer to 115V auxiliary output section
Tig torch runs hot	Cooler control cable is not plugged in	Turn machine off, plug control cable, then turn machine on
Machine displays ERR 11 when welding	Insufficient water in cooler	Check and refill water
	Air in water line	Activate trigger and depress Flow Sensor Bypass switch to prime cooler
	Cooler is not plugged in to 115V receptacle, insufficient coolant in cooler, TIG Torch is undersized (amperage capacity) for application, blown fuse, or faulty flow sensor inside cooler.	Initial Correction Measures: Check Cooler Connections, Fill Cooler with additional Low Conductivity Coolant (KP4159-1), Replace with higher amperage capacity TIG Torch. Replace 3A fuse. Depress Flow Sensor Off button to remove error code. Secondary Corrective Measures: Service cooler

CAUTION

If for any reason you do not understand the test procedures or are unable to perform the tests/repairs safely, contact your **Local Lincoln Authorized Field Service Facility** for technical troubleshooting assistance before you proceed.

WIRING DIAGRAM - ASPECT 375

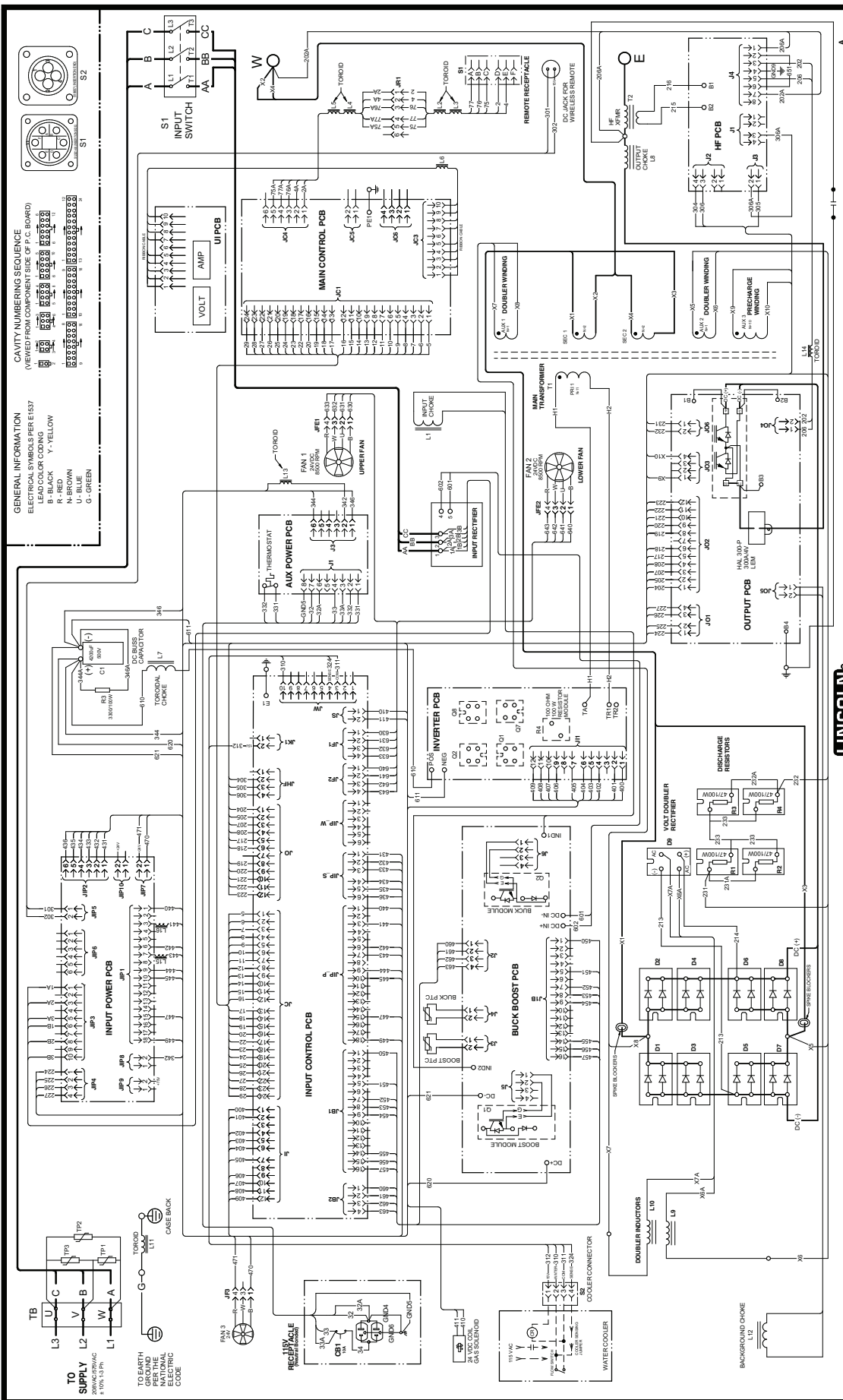

GENERAL INFORMATION
 ELECTRICAL SYMBOLS PER E1537
 B - BLACK
 R - RED
 N - BROWN
 U - BLUE
 G - GREEN

CAVITY NUMBERING SEQUENCE
 (VIEW FROM COMPONENT SIDE OF P.C. BOARD)
 ELECTRICAL CAVITY CODE
 1 2 3 4 5 6 7 8 9 10 11 12 13 14 15 16 17 18 19 20 21 22 23 24 25 26 27 28 29 30 31 32 33 34 35 36 37 38 39 40 41 42 43 44 45 46 47 48 49 50 51 52 53 54 55 56 57 58 59 60 61 62 63 64 65 66 67 68 69 70 71 72 73 74 75 76 77 78 79 80 81 82 83 84 85 86 87 88 89 90 91 92 93 94 95 96 97 98 99 100

LINCOLN ELECTRIC
 CLEVELAND, OHIO U.S.A.

NOTE: This diagram is for reference only. It may not be accurate for all machines covered by this manual. The specific diagram for a particular code is pasted inside the machine on one of the enclosure panels. If the diagram is illegible, write to the Service Department for a replacement. Give the equipment code number.

WIRING DIAGRAM - Aspect 375 Code 12258, 12558

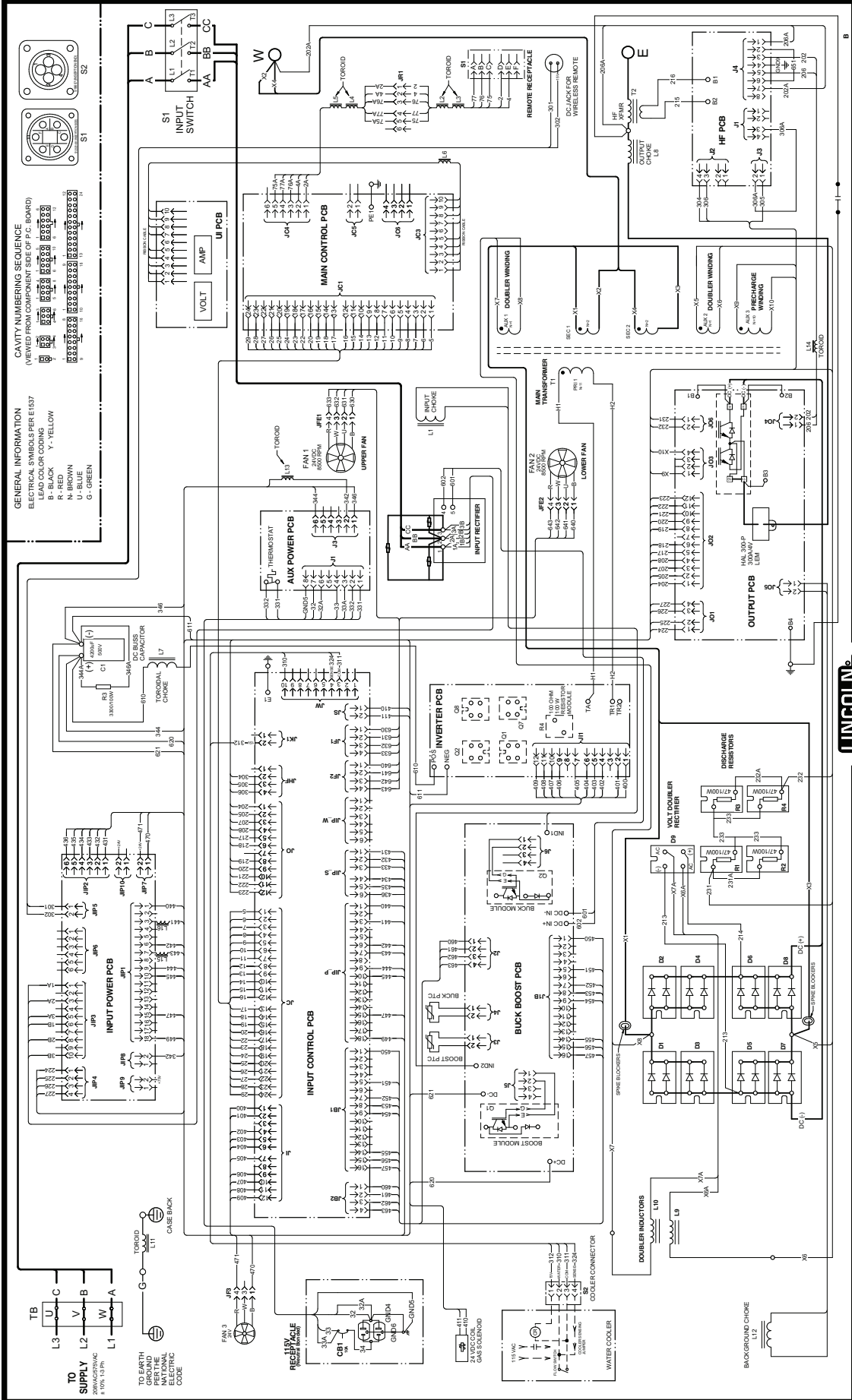

GENERAL INFORMATION

ELECTRICAL SYMBOLS PER E157

LEAD COLOR CODING
 B - BLACK
 R - RED
 N - BROWN
 U - BLUE
 G - GREEN

CAVITY NUMBERING SEQUENCE
 (VIEWED FROM COMPONENT SIDE OF P.C. BOARD)

1 2 3 4 5 6 7 8 9 10 11 12 13 14 15 16 17 18 19 20 21 22 23 24 25 26 27 28 29 30 31 32 33 34 35 36 37 38 39 40 41 42 43 44 45 46 47 48 49 50 51 52 53 54 55 56 57 58 59 60 61 62 63 64 65 66 67 68 69 70 71 72 73 74 75 76 77 78 79 80 81 82 83 84 85 86 87 88 89 90 91 92 93 94 95 96 97 98 99 100 101 102 103 104 105 106 107 108 109 110 111 112 113 114 115 116 117 118 119 120 121 122 123 124 125 126 127 128 129 130 131 132 133 134 135 136 137 138 139 140 141 142 143 144 145 146 147 148 149 150 151 152 153 154 155 156 157 158 159 160 161 162 163 164 165 166 167 168 169 170 171 172 173 174 175 176 177 178 179 180 181 182 183 184 185 186 187 188 189 190 191 192 193 194 195 196 197 198 199 200 201 202 203 204 205 206 207 208 209 210 211 212 213 214 215 216 217 218 219 220 221 222 223 224 225 226 227 228 229 230 231 232 233 234 235 236 237 238 239 240 241 242 243 244 245 246 247 248 249 250 251 252 253 254 255 256 257 258 259 260 261 262 263 264 265 266 267 268 269 270 271 272 273 274 275 276 277 278 279 280 281 282 283 284 285 286 287 288 289 290 291 292 293 294 295 296 297 298 299 300 301 302 303 304 305 306 307 308 309 310 311 312 313 314 315 316 317 318 319 320 321 322 323 324 325 326 327 328 329 330 331 332 333 334 335 336 337 338 339 340 341 342 343 344 345 346 347 348 349 350 351 352 353 354 355 356 357 358 359 360 361 362 363 364 365 366 367 368 369 370 371 372 373 374 375 376 377 378 379 380 381 382 383 384 385 386 387 388 389 390 391 392 393 394 395 396 397 398 399 400 401 402 403 404 405 406 407 408 409 410 411 412 413 414 415 416 417 418 419 420 421 422 423 424 425 426 427 428 429 430 431 432 433 434 435 436 437 438 439 440 441 442 443 444 445 446 447 448 449 450 451 452 453 454 455 456 457 458 459 460 461 462 463 464 465 466 467 468 469 470 471 472 473 474 475 476 477 478 479 480 481 482 483 484 485 486 487 488 489 490 491 492 493 494 495 496 497 498 499 500 501 502 503 504 505 506 507 508 509 510 511 512 513 514 515 516 517 518 519 520 521 522 523 524 525 526 527 528 529 530 531 532 533 534 535 536 537 538 539 540 541 542 543 544 545 546 547 548 549 550 551 552 553 554 555 556 557 558 559 560 561 562 563 564 565 566 567 568 569 570 571 572 573 574 575 576 577 578 579 580 581 582 583 584 585 586 587 588 589 590 591 592 593 594 595 596 597 598 599 600 601 602 603 604 605 606 607 608 609 610 611 612 613 614 615 616 617 618 619 620 621 622 623 624 625 626 627 628 629 630 631 632 633 634 635 636 637 638 639 640 641 642 643 644 645 646 647 648 649 650 651 652 653 654 655 656 657 658 659 660 661 662 663 664 665 666 667 668 669 670 671 672 673 674 675 676 677 678 679 680 681 682 683 684 685 686 687 688 689 690 691 692 693 694 695 696 697 698 699 700 701 702 703 704 705 706 707 708 709 710 711 712 713 714 715 716 717 718 719 720 721 722 723 724 725 726 727 728 729 730 731 732 733 734 735 736 737 738 739 740 741 742 743 744 745 746 747 748 749 750 751 752 753 754 755 756 757 758 759 760 761 762 763 764 765 766 767 768 769 770 771 772 773 774 775 776 777 778 779 780 781 782 783 784 785 786 787 788 789 790 791 792 793 794 795 796 797 798 799 800 801 802 803 804 805 806 807 808 809 810 811 812 813 814 815 816 817 818 819 820 821 822 823 824 825 826 827 828 829 830 831 832 833 834 835 836 837 838 839 840 841 842 843 844 845 846 847 848 849 850 851 852 853 854 855 856 857 858 859 860 861 862 863 864 865 866 867 868 869 870 871 872 873 874 875 876 877 878 879 880 881 882 883 884 885 886 887 888 889 890 891 892 893 894 895 896 897 898 899 900 901 902 903 904 905 906 907 908 909 910 911 912 913 914 915 916 917 918 919 920 921 922 923 924 925 926 927 928 929 930 931 932 933 934 935 936 937 938 939 940 941 942 943 944 945 946 947 948 949 950 951 952 953 954 955 956 957 958 959 960 961 962 963 964 965 966 967 968 969 970 971 972 973 974 975 976 977 978 979 980 981 982 983 984 985 986 987 988 989 990 991 992 993 994 995 996 997 998 999 1000

LINCOLN ELECTRIC
 GREENWOOD, OHIO U.S.A.

PRINT TO 8.25 X 11.00

NOTE: This diagram is for reference only. It may not be accurate for all machines covered by this manual. The specific diagram for a particular code is pasted inside the machine on one of the enclosure panels. If the diagram is illegible, write to the Service Department for a replacement. Give the equipment code number.

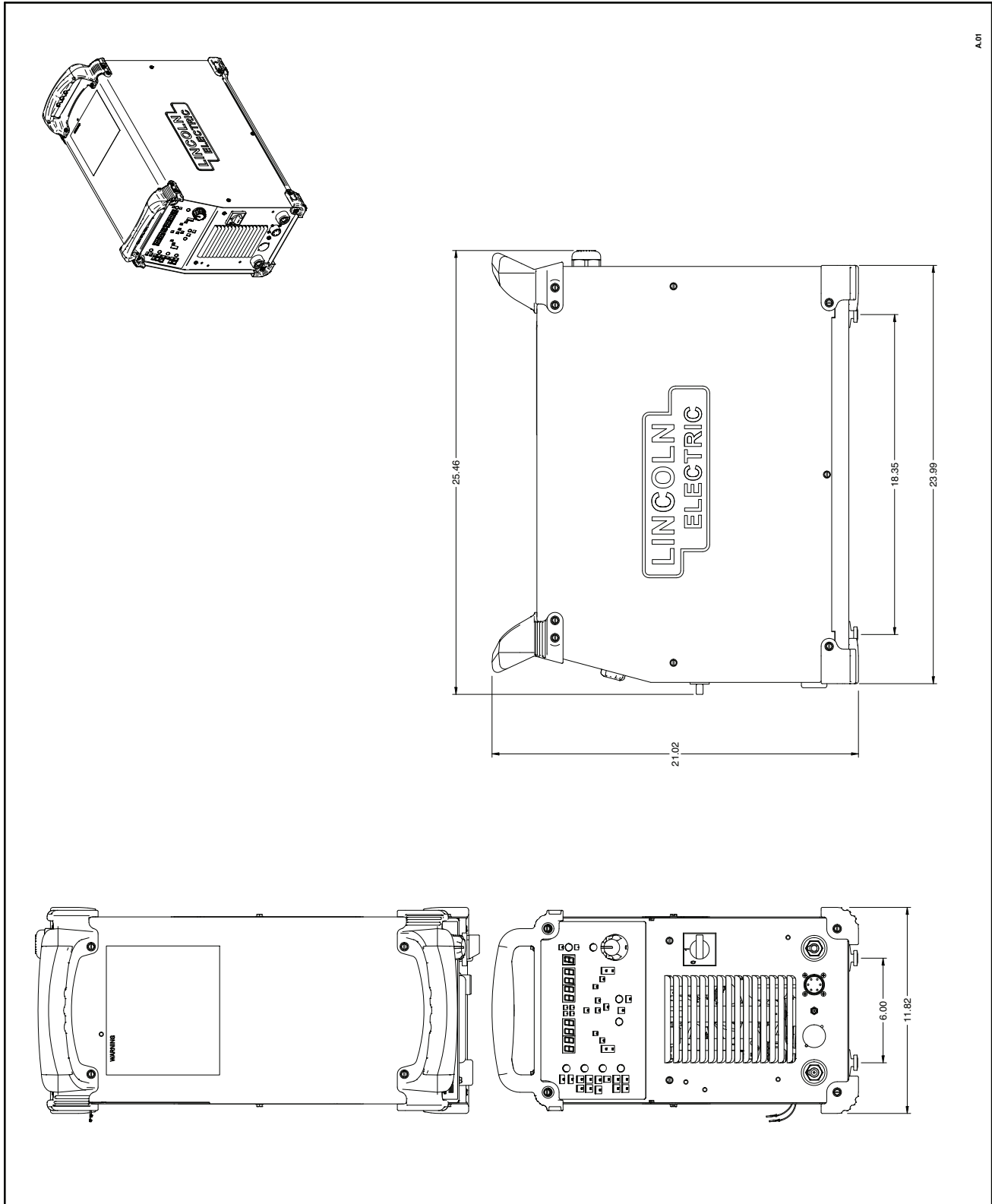

A.01
L16481



Service Navigator 2.0

Aspect 375 - 12558

TIG Welders

Aspect

Aspect 375 - 12558

Index of Sub Assemblies - 12558	1
Miscellaneous Items	3
Case Front Assembly	5
Base and Center Assembly	7
Heat Sink Assembly.....	10
Mid Shelf Assembly	13
Top Shelf Assembly.....	15
Case Back Assembly.....	17
Wraparound.....	19

THIS PAGE INTENTIONALLY LEFT BLANK

Index of Sub Assemblies - 12558

KEY	PART NUMBER	DESCRIPTION	QTY
	P-984-A	INDEX OF SUB ASSEMBLIES	AR
	P-984-B.2	MISCELLANEOUS ITEMS	AR
1	P-984-C	CASE FRONT ASSEMBLY	AR
2	P-984-D	BASE AND CENTER ASSEMBLY	AR
3	P-984-E	HEAT SINK ASSEMBLY	AR
4	P-984-F	MID SHELF ASSEMBLY	AR
5	P-984-G	TOP SHELF ASSEMBLY	AR
6	P-984-H	CASE BACK ASSEMBLY	AR
7	P-984-J	WRAPAROUND	AR

Index of Sub Assemblies - 12558

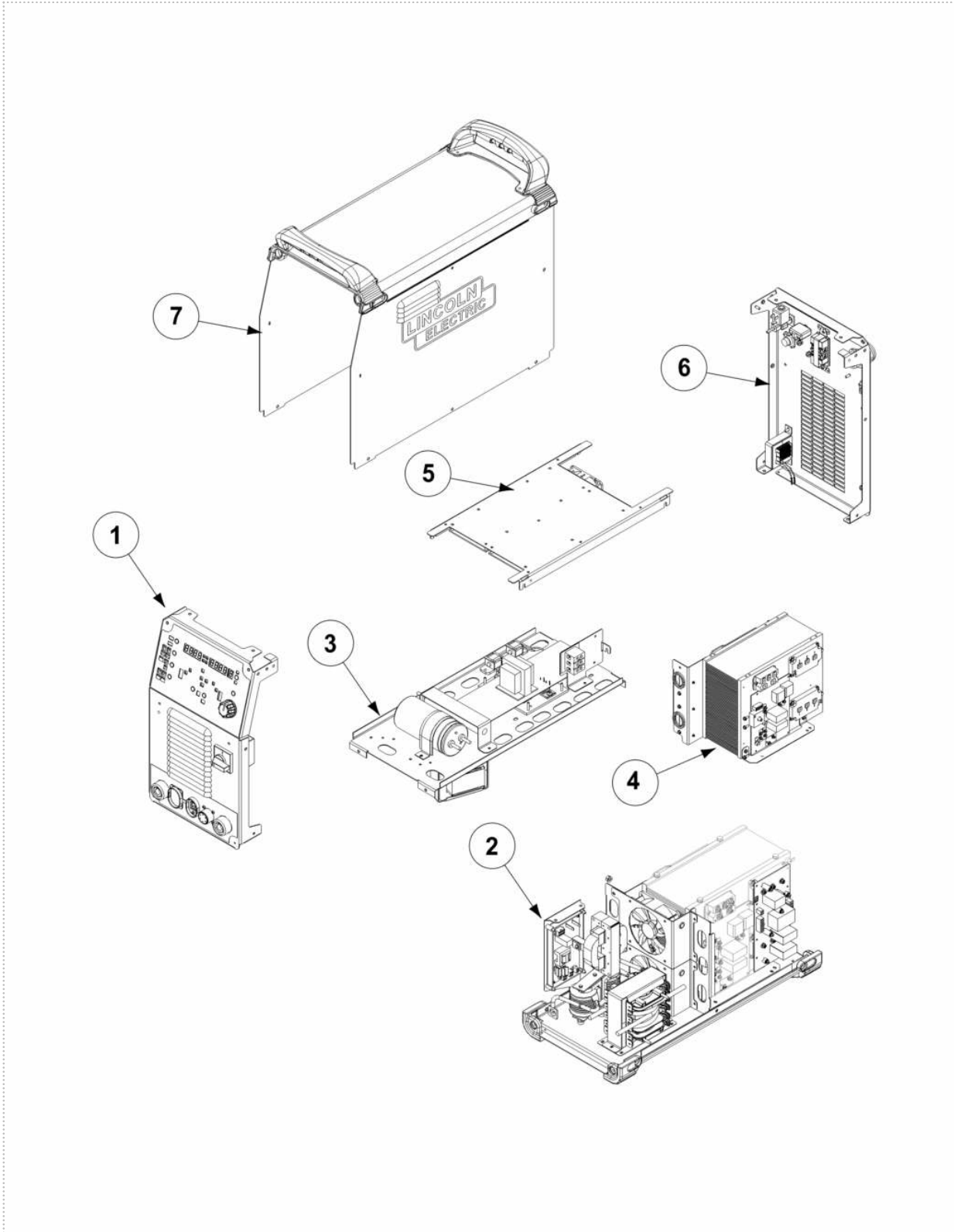

P-984-A.jpg

Miscellaneous Items

KEY	PART NUMBER	DESCRIPTION	QTY
	9ST10642-209	FLEX TUBE	1
	9SS20710-6	HOSE CLAMP	2
	K1622-5	TWIST-MATE ADAPTER ASBLY	1
	K3950-1	COOL ARC 47	1
	K4843-18F-2	CALIBER 18 SERIES TIG TORCH	1
	K3949-1	275/375 AMP TIG INVERTER CART	1
	K918-4	HEAVY DUTY 25' ZIPPER COVER	1
	3100211	FLOW/REG355-2AR-58010	1
	KP4760-HD	CALIBER PTW-18 TORCH	1
	KP509	PARTS KIT FOR PTW-18 PTA-26 & PTW-350	1

Miscellaneous Items

**NO IMAGE
AVAILABLE**

No Image

Case Front Assembly

KEY	PART NUMBER	DESCRIPTION	QTY
	9SG8661	CASE FRONT ASSEMBLY	1
1	9SG7459	CASE FRONT	1
2	9SS29828-1	FOAM	1
3	9SS29828-2	FOAM	1
4	9SS29828-3	FOAM	1
5	9SS29828-4	FOAM	1
6A	9SG8668-1	UI PC BOARD ASSEMBLY	1
6B	9SS19300-7	SUPPORTPCBSNAP-IN0.63	3
	9SCF000337	#6-32X.375PPNHS	4
	9SE106A-13	LOCKWASHER	4
7	9SS29667	PC BD STANDOFF	2
8A	9SG8670-1	MAIN CONTROL PC BOARD ASSEMBLY	1
	9SCF000337	#6-32X.375PPNHS	2
	9SE106A-13	LOCKWASHER	2
9	9SL16553	DECAL	1
10A	9SM22444	ETHERNET COVER	1
10B	9SS8025-96	SELF TAPPING SCREW	2
11	9SS29508	TWIST MATE RECEPTACLE	1
12	9SS29509	TWIST MADE RECEPTACLE WITH AIR PASS	1
	9SS18250-1030	PLUG & LEAD ASBLY	1
13A	9SS12021-68	CONNECTOR	1
13B	9SS8025-96	SELF TAPPING SCREW	4
13C	9SS17062-10	CABLE CONNECTOR CAP	1
14	9SS18250-1029	PLUG & LEAD ASBLY	1
15	9SM22778-2	KNOB 1.5"	1
15A	9ST14034-4	SHAFT SEAL	1
	9SS9225-99	SELF TAPPING SCREW	4
17	9SS29541-1	MAIN POWER SWITCH	1
18	9SG7626-1	NAMEPLATE	1
	9SS18250-1026	PLUG & LEAD ASBLY	1

Case Front Assembly

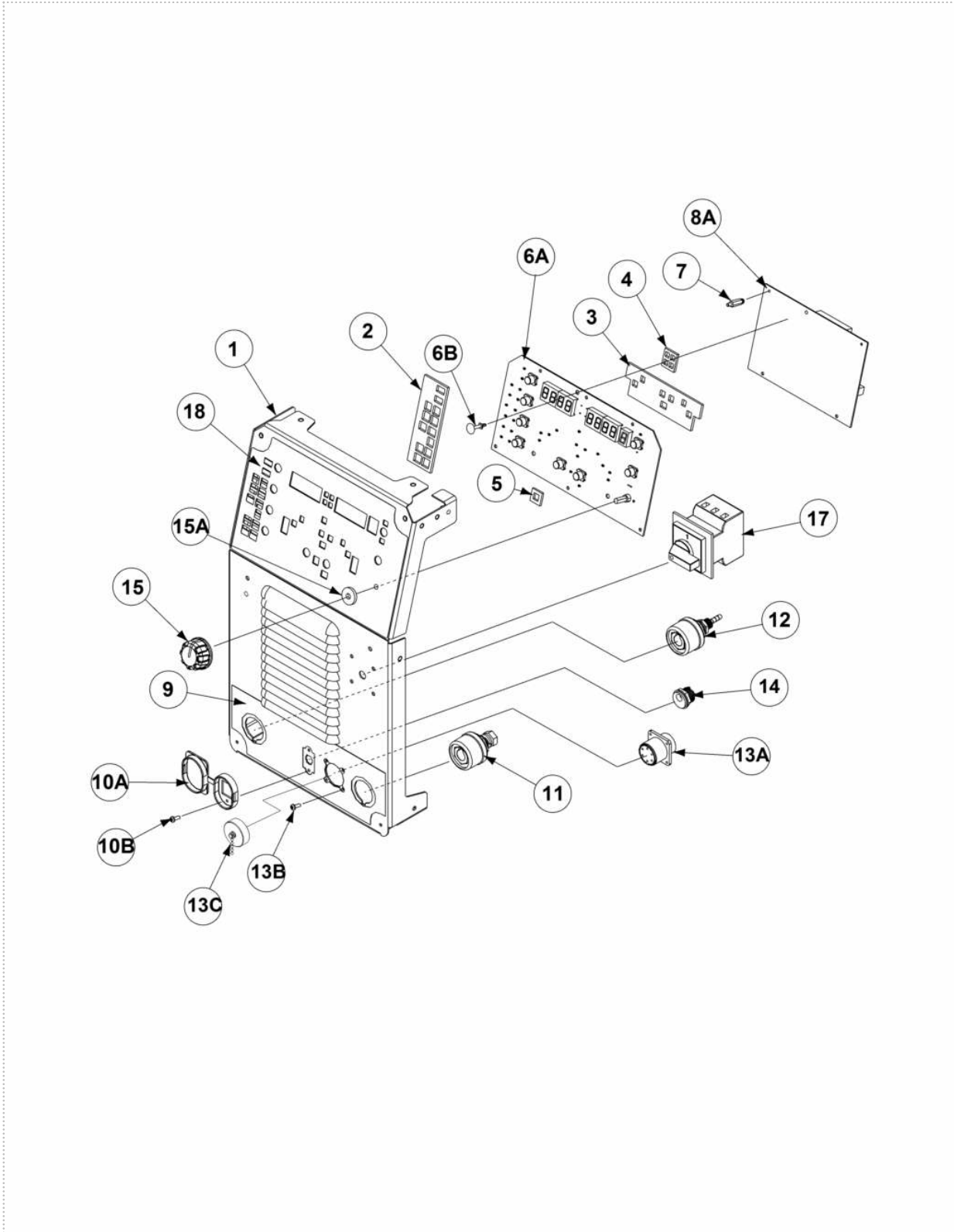

P-984-C.jpg

Base and Center Assembly

KEY	PART NUMBER	DESCRIPTION	QTY
	9SG8684	BASE AND CENTER ASSEMBLY	1
	9SM25764	BASE ASSEMBLY	1
1B	9SG8665	BOTTOM COVER	1
1C	9SS28070	QUICK LOCK FOOT	4
1D	9SCF000012	1/4-20X.50HHCS	4
1E	9SE106A-2	LOCKWASHER	4
1F	9SS29507	CORNER CAP	4
1G	9SS9225-100	SELF TAPPING SCREW	4
1H	9SS9262-184	WASHER	4
1J	9SM25069	BASE MOUNTING BRACKET	2
1K	9ST9187-13	#10-24HLN-1817/1-NYLON INSERT	8
	9SL17037	BOTTOM SHELF/TRANSFORMER ASSEMBLY	1
2B	9SG8666	BOTTOM SHELF	1
2C	9SG7524	HIGH FREQ TRANSFORMER	1
2D	9SS29965-1	METRIC SEMS SCREW	3
2E	9SG7523	TRANSFORMER	1
2F	9ST9187-13	#10-24HLN-1817/1-NYLON INSERT	4
2G	9SCF000010	#10-24HN	2
	9SS9225-99	SELF TAPPING SCREW	2
	9SS9225-99	SELF TAPPING SCREW	4
4A	9SM24752-1	RIGHT BAFFLE	1
4B	9SS9225-99	SELF TAPPING SCREW	2
4C	9SE106A-1	LOCKWASHER	2
5A	9SM25078	FAN ASBLY	2
5B	9SM24748	MIDDLE FAN BRACKET	2
5C	9SS9225-99	SELF TAPPING SCREW	16
5D	9ST12380-4	BUSHING	2
6	9SS29543	GROMMET	5
7	9SL16392-1	BUCK BOOST PC BD ASBLY	1
8	9SS29965-3	METRIC SEMS SCREW	6
9A	9SM25058	HIGH FREQ BD BRACKET	1
9B	9SG7372-3	HI FREQUENCY PC BD ASBLY	1
9C	9ST9187-13	#10-24HLN-1817/1-NYLON INSERT	4
9D	9SS9225-99	SELF TAPPING SCREW	3

Base and Center Assembly

KEY	PART NUMBER	DESCRIPTION	QTY
10A	9SS29537-4	BUS BAR	1
	9SE106A-1	LOCKWASHER	2
	9SS25930-8	M6-1.00 TORX HEAD SCREW	2
11A	9SM24767	CHOKE ASBLY	1
	9SS9225-99	SELF TAPPING SCREW	2
	9SS18250-1053	PLUG & LEAD ASBLY	1
	9SS18250-1037	PLUG & LEAD ASBLY	1

Base and Center Assembly

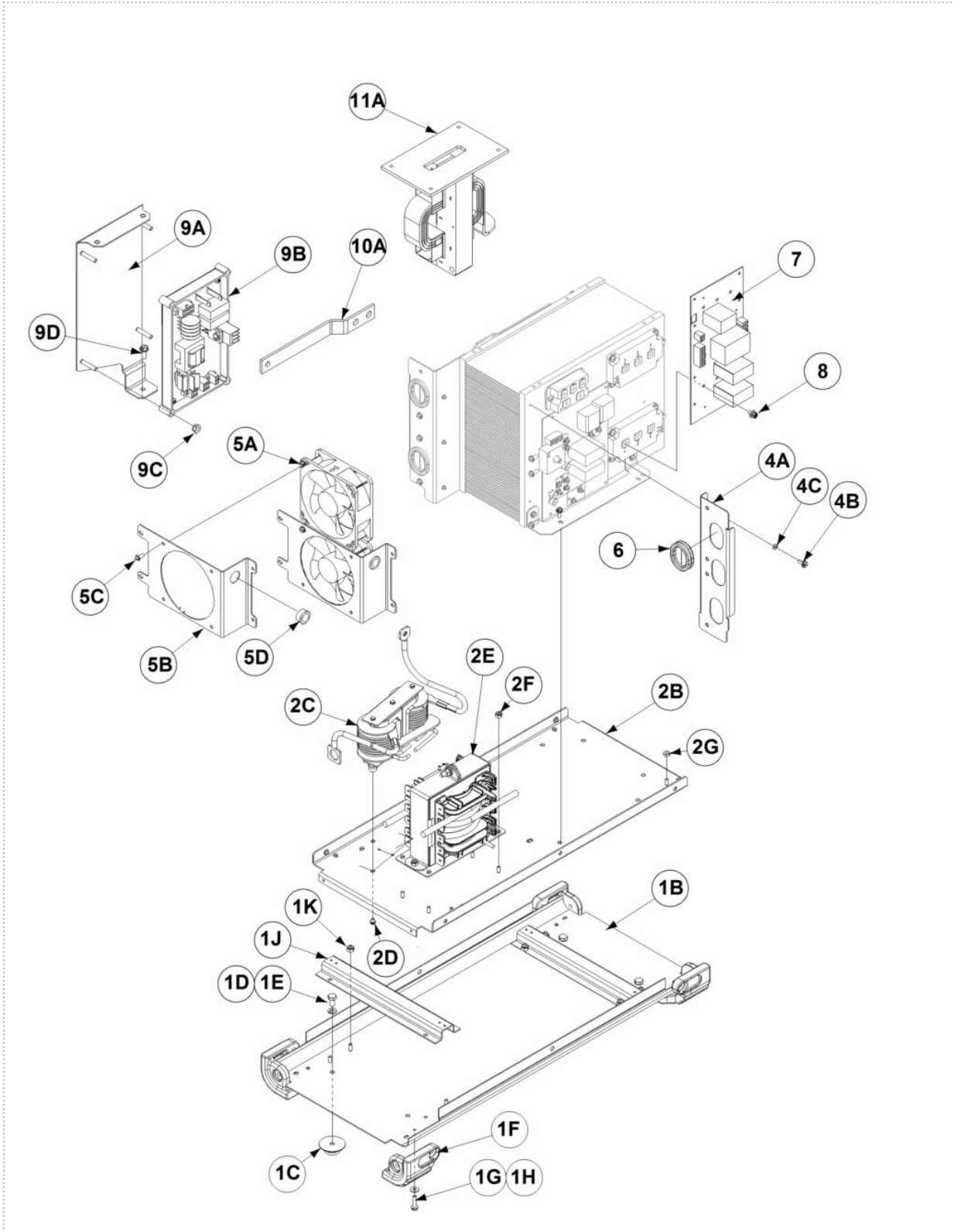

P-984-D.jpg

Printed 08/08/2016 at 13:38:26. Produced by Enigma.

Heat Sink Assembly

KEY	PART NUMBER	DESCRIPTION	QTY
	9SG8688	HEAT SINK ASSEMBLY	1
4A	9SG7686-1	HEATSINK	1
5A	9SM24769-1	IGBT W/ULTRA FAST DIODE (SOT 227)	4
5B	9ST9447-87	SOCKET HEAD CAP SCREW #6-32X.50	8
5C	9SE106A-13	LOCKWASHER	8
6A	9SM24912-5	SOT-227B HEAT SINK MOUNT POWER RESISTOR	5
6B	9ST9447-87	SOCKET HEAD CAP SCREW #6-32X.50	10
6C	9SE106A-13	LOCKWASHER	10
7A	9SM24768-2	POWER MODULE	1
7B	9SS25930-5	TORX BUTTON HEAD SCREW #10-24X.62	4
7C	9SE106A-1	LOCKWASHER	4
8A	9SM24768-5	LOW PROFILE IGBT MODULE	1
8B	9SS25930-5	TORX BUTTON HEAD SCREW #10-24X.62	4
8C	9SE106A-1	LOCKWASHER	4
9A	9SM15454-18	INPUT RECTIFIER MODULE	1
9B	9SS25930-5	TORX BUTTON HEAD SCREW #10-24X.62	2
9C	9SE106A-1	LOCKWASHER	2
10A	9SM24769-3	ISOTOP FULL BRIDGE DIODES 60A	1
10B	9ST9447-87	SOCKET HEAD CAP SCREW #6-32X.50	2
10C	9SE106A-13	LOCKWASHER	2
11A	9SM24769-2	ISOTOP PARALLEL DIODES	8
11B	9ST9447-87	SOCKET HEAD CAP SCREW #6-32X.50	16
11C	9SE106A-13	LOCKWASHER	16
12A	9SM24752-2	LEFT BAFFLE	1
12B	9SS29667	PC BD STANDOFF	2
12C	9SS25930-5	TORX BUTTON HEAD SCREW #10-24X.62	2
12D	9SE106A-1	LOCKWASHER	2
14A	9SM25754	HEATSINK BRACKET	2
14B	9SS25930-5	TORX BUTTON HEAD SCREW #10-24X.62	4
14C	9SE106A-1	LOCKWASHER	4
	9SS30400	PTC THERMISTOR ASSEMBLY	2
16A	9SG8679-1	INVERTER PC BD ASSEMBLY	1
	9SS29965-1	METRIC SEMS SCREW	18
17A	9SG7730-1	OUTPUT PC BD ASBLY	1

Heat Sink Assembly

KEY	PART NUMBER	DESCRIPTION	QTY
17B	9SS25930-5	TORX BUTTON HEAD SCREW #10-24X.62	4
17C	9SE106A-1	LOCKWASHER	4
17D	9SCF000337	#6-32X.375PPNHS	2
17E	9SE106A-13	LOCKWASHER	2
18A	9SS29537-1	BUS BAR	1
18B	9SS29965-2	METRIC SEMS SCREW	8
18C	9SS25930-8	M6-1.00 TORX HEAD SCREW	1
18D	9SE106A-2	LOCKWASHER	1
19A	9SS29537-2	BUS BAR	1
19B	9SS29965-2	METRIC SEMS SCREW	8
19C	9SS25930-8	M6-1.00 TORX HEAD SCREW	1
19D	9SE106A-2	LOCKWASHER	1
20A	9SS29537-3	BUS BAR	2
20B	9ST11827-23	CARRIAGE BOLT	2
20C	9SS29965-2	METRIC SEMS SCREW	16
	9SS18250-1043	PLUG & LEAD ASBLY	1
	9SS29965-1	METRIC SEMS SCREW	2
	9SS18250-1028	PLUG & LEAD ASBLY	2

Heat Sink Assembly

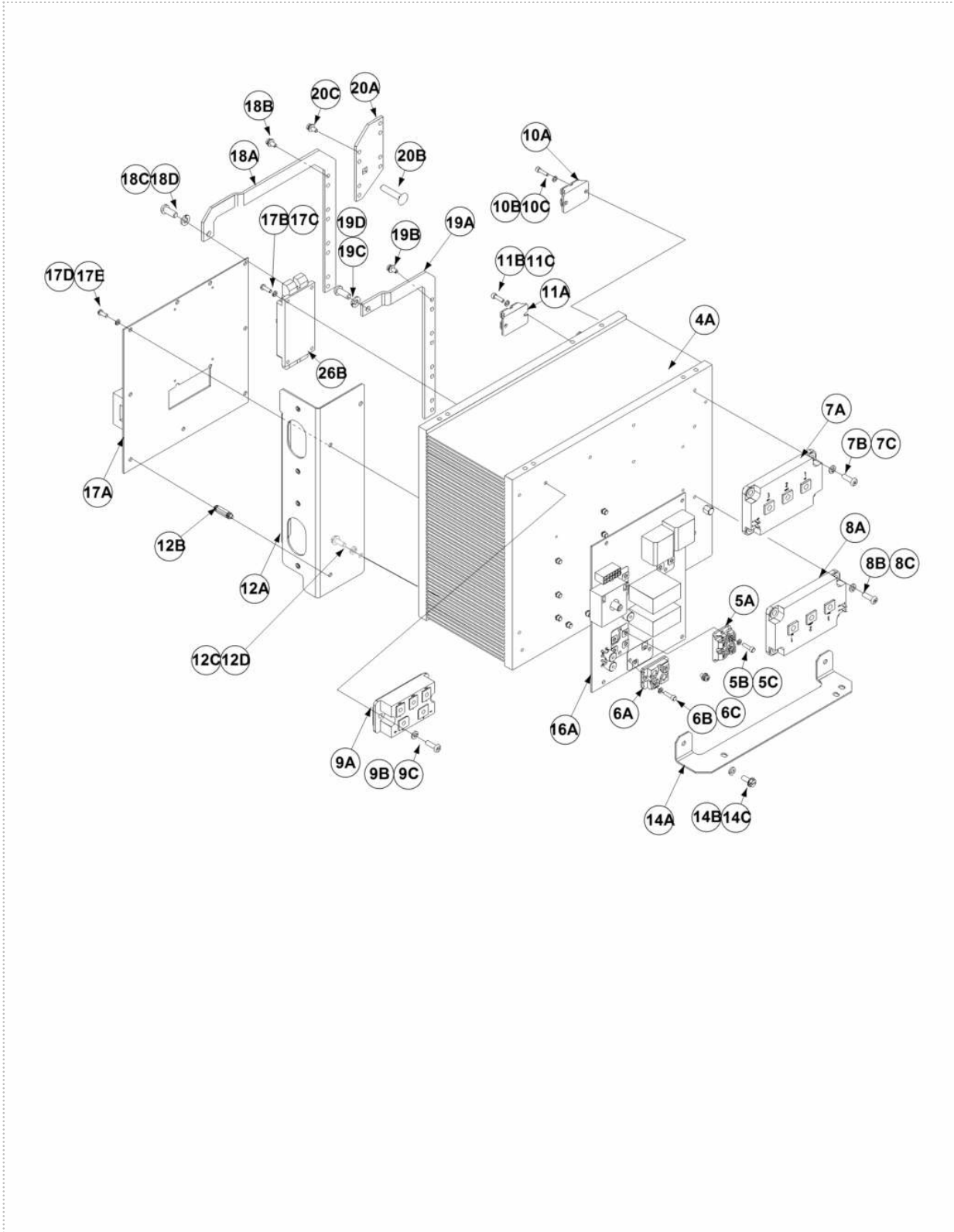

P-984-E.jpg

Mid Shelf Assembly

KEY	PART NUMBER	DESCRIPTION	QTY
	9SG7856	MID SHELF ASSEMBLY	1
1	9SL16307	TOP SHELF	1
2A	9SM21489-3	INPUT CHOKE	1
2B	9SM21468	INPUT CHOKE BRACKET	1
2C	9ST9187-13	#10-24HLN-1817/1-NYLON INSERT	2
3A	9ST12218-42	DOUBLER CHOKE	2
3B	9ST9187-13	#10-24HLN-1817/1-NYLON INSERT	4
4A	9SG7467-1	AUXILIARY POWER PC BD	1
4B	9ST9187-13	#10-24HLN-1817/1-NYLON INSERT	4
5	9SCF000010	#10-24HN	3
6A	9SCF000012	1/4-20X.50HHCS	4
6B	9SE106A-2	LOCKWASHER	4
7	9SS29543	GROMMET	9
8A	9SS13490-249	CAPACITOR	1
8B	9SS29506	CAPACITOR BRACKET	1
8D	9SM25059	INSULATION	1
8E	9ST9187-13	#10-24HLN-1817/1-NYLON INSERT	1
9	9ST12380-8	BUSHING	2
	9SM25057	RESISTOR BRACKET	1
	9ST9187-13	#10-24HLN-1817/1-NYLON INSERT	2
10C	9SS10404-147	RESISTOR WW 100 WATT 3200 5%	1
10D	9ST4479-A	INSULATING WASHER	2
10E	9SCF000191	#10-24X7.50RHS	1
10F	9SS9262-27	PLAIN WASHER	2
10G	9SE106A-1	LOCKWASHER	1
10H	9SCF000010	#10-24HN	1
11	9SM24954	DISCONNECT PANEL	1
	9ST9187-13	#10-24HLN-1817/1-NYLON INSERT	2
11B	9SS20763-3	TERMINAL BLOCK	1
	9ST9447-129	#8-32X1.25SHCS	2
13	9SS18491-3	M.O.V. ASBLY	1
	9SS18250-1032	PLUG & LEAD ASBLY	1

Mid Shelf Assembly

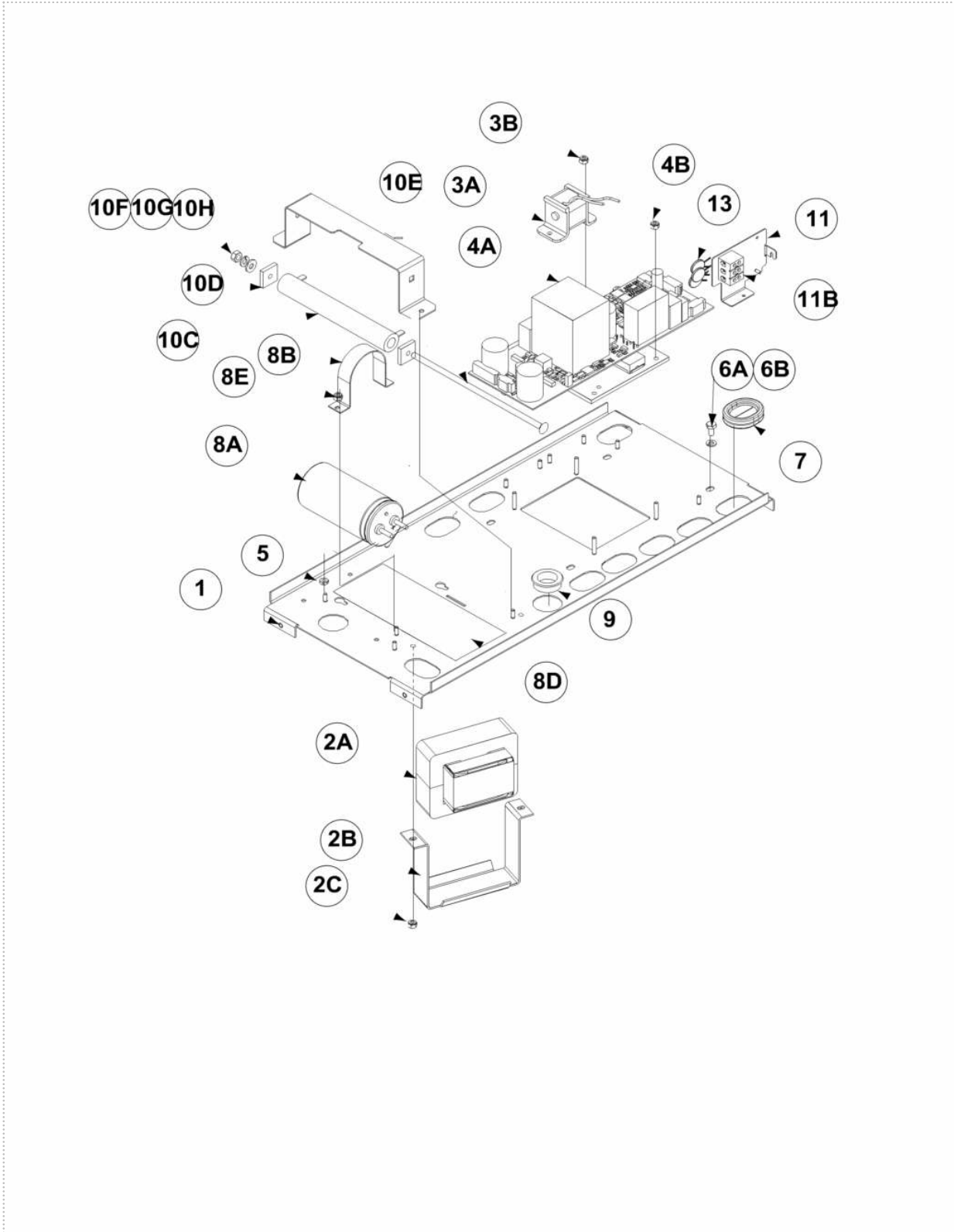

P-984-F.jpg

Top Shelf Assembly

KEY	PART NUMBER	DESCRIPTION	QTY
	9SL17036	TOP SHELF ASSEMBLY	1
1	9SG7736	UPPER BOARD MOUNT	1
2A	9SCF000010	#10-24HN	2
2B	9SE106A-1	LOCKWASHER	1
3A	9SM25079	FAN ASBLY	1
3B	9SS9225-99	SELF TAPPING SCREW	3
4A	9SG8675-1	INPUT POWER PC BD ASSEMBLY	1
4B	9SCF000337	#6-32X.375PPNHS	8
4C	9SE106A-13	LOCKWASHER	8
5A	9SG7471-1	INPUT CONTROL PC BD	1
5B	9SCF000337	#6-32X.375PPNHS	6
5C	9SE106A-13	LOCKWASHER	6
	9SS18250-1040	PLUG & LEAD ASBLY	1

Top Shelf Assembly

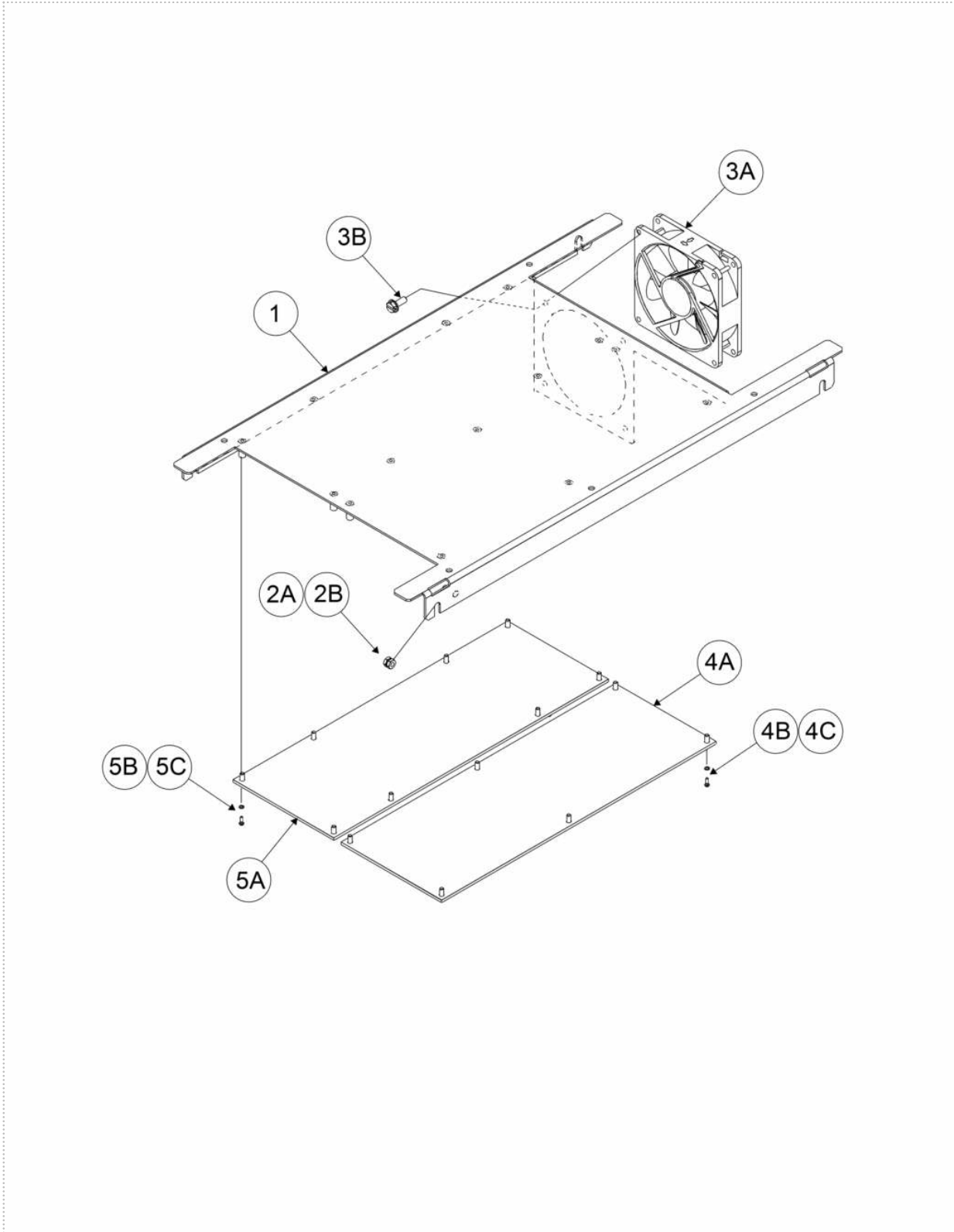

P-984-G.jpg

Case Back Assembly

KEY	PART NUMBER	DESCRIPTION	QTY
	9SG8662	CASE BACK ASSEMBLY	1
1	9SG8663	CASE BACK	1
2	9SL16553	DECAL	1
3A	9SS20184	RECEPTACLE-DUPLEX (20A-125V)	1
3B	9SM16996	RECEPTACLE COVER	1
3C	9SM22176	DECAL (115V RECEPTACLE)	1
3D	9SS9225-100	SELF TAPPING SCREW	2
3E	9ST9187-13	#10-24HLN-1817/1-NYLON INSERT	2
	9SS18250-1024	PLUG & LEAD ASBLY	1
4A	9ST12287-20	CIRCUIT BREAKER-10A250VAC	1
4B	9SS22061-3	SEALING BOOT	1
5A	9SS19999	CORD GRIP CONNECTOR	1
5B	9ST14370-3	CONDUIT LOCKNUT	1
6A	9SM17294-17	24VDC SOLENOID VALVE ASSEMBLY	1
6B	9ST14370-1	CONDUIT LOCKNUT	1
6C	9SS9262-149	PLAIN WASHER	1
7A	9SM24732	BACKGROUND CHOKE ASBLY	1
7B	9SS29480	BACKGROUND CHOKE MTG BRACKET	1
7C	9ST9187-13	#10-24HLN-1817/1-NYLON INSERT	2
8	9ST13260-4	DECAL-EARTH GROUND CONN	1
9	9SM25753	RATING PLATE	1
10A	9SCF000010	#10-24HN	4
10B	9SE106A-1	LOCKWASHER	1
	9SG7756	HARNESS	1
11A	9SS18657	SQUARE FLANGE FEMALE RECEPTACLE	1
11B	9SS8025-96	SELF TAPPING SCREW	2
	9SS18573-17	INPUT LEAD ASBLY	1
	9SS19316-7	TOROID	1
13	9ST12563-10	LEAD CLAMP	1

Case Back Assembly

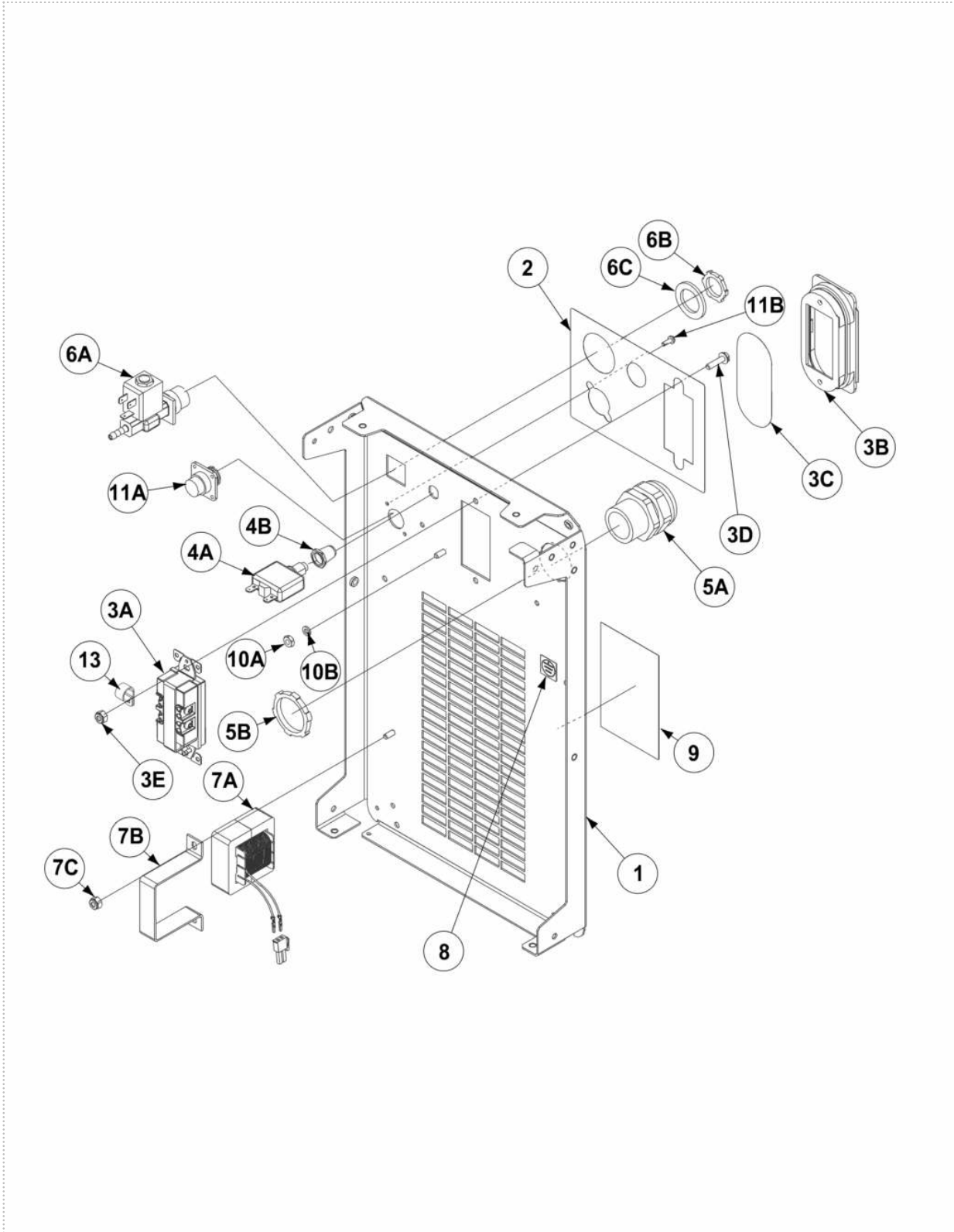

P-984-H.jpg

Wraparound

KEY	PART NUMBER	DESCRIPTION	QTY
1A	9SG8664	WRAPAROUND	1
1B	9SS9225-99	SELF TAPPING SCREW	6
	9SS9225-100	SELF TAPPING SCREW	4
	9SS9262-184	WASHER	4
2A	9SM24770	HANDLE	2
2B	9SS9225-100	SELF TAPPING SCREW	16
2C	9SS9262-184	WASHER	16
5	9SS27368-4	DECAL LE LOGO	2
6	9SL8064-1	WARNING DECAL (INTERNATIONAL)	1
7	9SS22127-2	DECAL-WARRANTY	1
8	9SS28039-2	DECAL GREEN INITIATIVE	1
9	9SG8664-1	RIGHT CASE SIDE	1

Wraparound

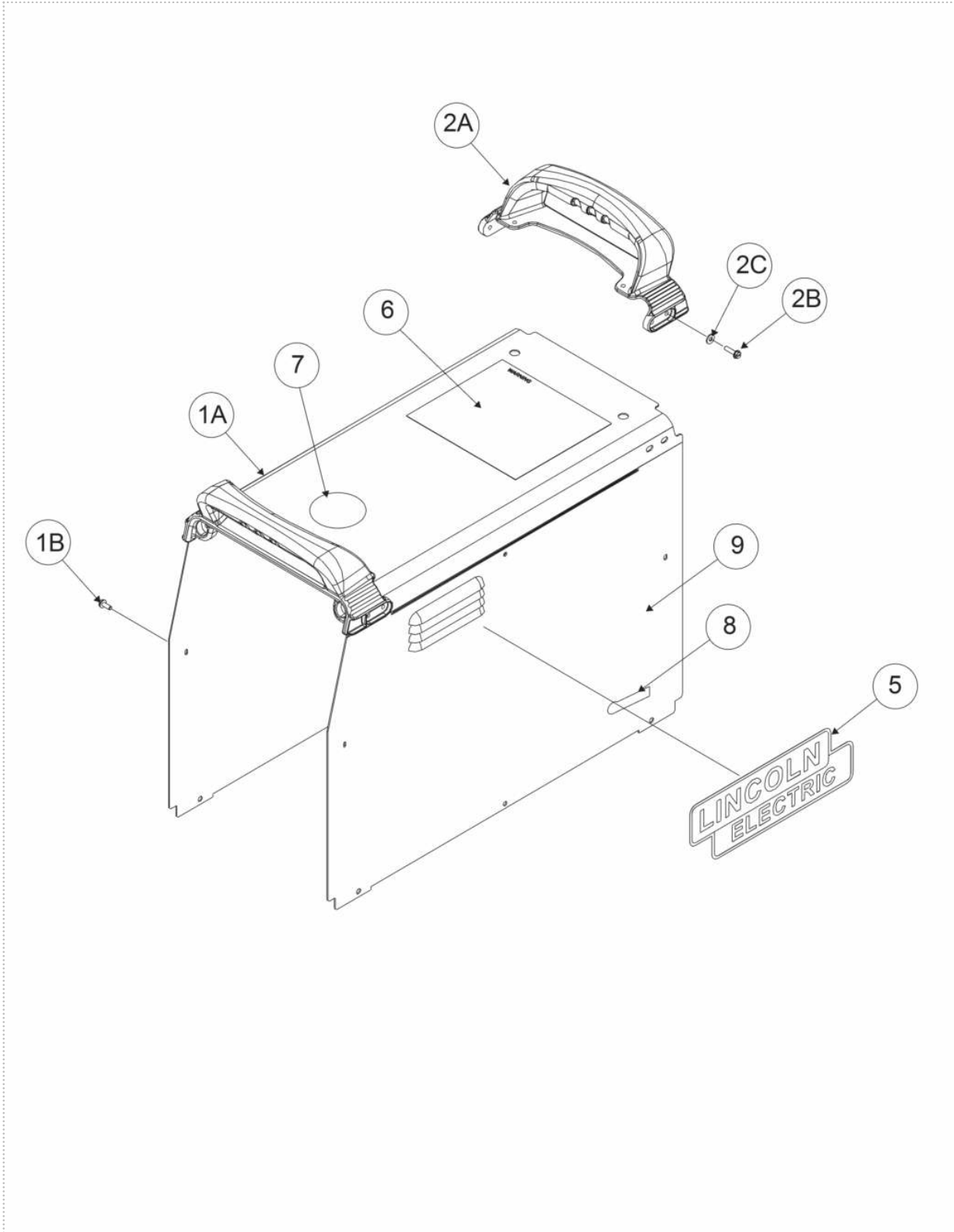

P-984-J.jpg

			
WARNING	<ul style="list-style-type: none"> ● Do not touch electrically live parts or electrode with skin or wet clothing. ● Insulate yourself from work and ground. 	<ul style="list-style-type: none"> ● Keep flammable materials away. 	<ul style="list-style-type: none"> ● Wear eye, ear and body protection.
Spanish AVISO DE PRECAUCION	<ul style="list-style-type: none"> ● No toque las partes o los electrodos bajo carga con la piel o ropa mojada. ● Aíslese del trabajo y de la tierra. 	<ul style="list-style-type: none"> ● Mantenga el material combustible fuera del área de trabajo. 	<ul style="list-style-type: none"> ● Protéjase los ojos, los oídos y el cuerpo.
French ATTENTION	<ul style="list-style-type: none"> ● Ne laissez ni la peau ni des vêtements mouillés entrer en contact avec des pièces sous tension. ● Isolez-vous du travail et de la terre. 	<ul style="list-style-type: none"> ● Gardez à l'écart de tout matériel inflammable. 	<ul style="list-style-type: none"> ● Protégez vos yeux, vos oreilles et votre corps.
German WARNUNG	<ul style="list-style-type: none"> ● Berühren Sie keine stromführenden Teile oder Elektroden mit Ihrem Körper oder feuchter Kleidung! ● Isolieren Sie sich von den Elektroden und dem Erdboden! 	<ul style="list-style-type: none"> ● Entfernen Sie brennbares Material! 	<ul style="list-style-type: none"> ● Tragen Sie Augen-, Ohren- und Körperschutz!
Portuguese ATENÇÃO	<ul style="list-style-type: none"> ● Não toque partes elétricas e electrodos com a pele ou roupa molhada. ● Isole-se da peça e terra. 	<ul style="list-style-type: none"> ● Mantenha inflamáveis bem guardados. 	<ul style="list-style-type: none"> ● Use proteção para a vista, ouvido e corpo.
Japanese 注意事項	<ul style="list-style-type: none"> ● 通電中の電気部品、又は溶材にヒフやぬれた布で触れないこと。 ● 施工物やアースから身体が絶縁されている様にして下さい。 	<ul style="list-style-type: none"> ● 燃えやすいものの側での溶接作業は絶対にしてはなりません。 	<ul style="list-style-type: none"> ● 目、耳及び身体に保護具をして下さい。
Chinese 警告	<ul style="list-style-type: none"> ● 皮肤或湿衣物切勿接触带电部件及焊条。 ● 使你自已与地面和工件绝缘。 	<ul style="list-style-type: none"> ● 把一切易燃物品移离工作场所。 	<ul style="list-style-type: none"> ● 佩戴眼、耳及身体劳动保护用具。
Korean 위험	<ul style="list-style-type: none"> ● 전도체나 용접봉을 젖은 헝겍 또는 피부로 절대 접촉치 마십시오. ● 모재와 접지를 접촉치 마십시오. 	<ul style="list-style-type: none"> ● 인화성 물질을 접근시키지 마십시오. 	<ul style="list-style-type: none"> ● 눈, 귀와 몸에 보호장구를 착용하십시오.
Arabic تحذير	<ul style="list-style-type: none"> ● لا تلمس الاجزاء التي يسري فيها التيار الكهربائي أو الألكترود بجسدك أو بالملابس المبللة بالماء. ● ضع عازلا على جسمك خلال العمل. 	<ul style="list-style-type: none"> ● ضع المواد القابلة للاشتعال في مكان بعيد. 	<ul style="list-style-type: none"> ● ضع أدوات وملابس واقية على عينيك وأذنيك وجسمك.

READ AND UNDERSTAND THE MANUFACTURER'S INSTRUCTION FOR THIS EQUIPMENT AND THE CONSUMABLES TO BE USED AND FOLLOW YOUR EMPLOYER'S SAFETY PRACTICES.

SE RECOMIENDA LEER Y ENTENDER LAS INSTRUCCIONES DEL FABRICANTE PARA EL USO DE ESTE EQUIPO Y LOS CONSUMIBLES QUE VA A UTILIZAR, SIGA LAS MEDIDAS DE SEGURIDAD DE SU SUPERVISOR.

LISEZ ET COMPRENEZ LES INSTRUCTIONS DU FABRICANT EN CE QUI REGARDE CET EQUIPMENT ET LES PRODUITS A ETRE EMPLOYES ET SUIVEZ LES PROCEDURES DE SECURITE DE VOTRE EMPLOYEUR.

LESEN SIE UND BEFOLGEN SIE DIE BETRIEBSANLEITUNG DER ANLAGE UND DEN ELEKTRODENEINSATZ DES HERSTELLERS. DIE UNFALLVERHÜTUNGSVORSCHRIFTEN DES ARBEITGEBERS SIND EBENFALLS ZU BEACHTEN.

			
<ul style="list-style-type: none"> ● Keep your head out of fumes. ● Use ventilation or exhaust to remove fumes from breathing zone. 	<ul style="list-style-type: none"> ● Turn power off before servicing. 	<ul style="list-style-type: none"> ● Do not operate with panel open or guards off. 	WARNING
<ul style="list-style-type: none"> ● Los humos fuera de la zona de respiración. ● Mantenga la cabeza fuera de los humos. Utilice ventilación o aspiración para gases. 	<ul style="list-style-type: none"> ● Desconectar el cable de alimentación de poder de la máquina antes de iniciar cualquier servicio. 	<ul style="list-style-type: none"> ● No operar con panel abierto o guardas quitadas. 	Spanish AVISO DE PRECAUCION
<ul style="list-style-type: none"> ● Gardez la tête à l'écart des fumées. ● Utilisez un ventilateur ou un aspirateur pour ôter les fumées des zones de travail. 	<ul style="list-style-type: none"> ● Débranchez le courant avant l'entretien. 	<ul style="list-style-type: none"> ● N'opérez pas avec les panneaux ouverts ou avec les dispositifs de protection enlevés. 	French ATTENTION
<ul style="list-style-type: none"> ● Vermeiden Sie das Einatmen von Schweißrauch! ● Sorgen Sie für gute Be- und Entlüftung des Arbeitsplatzes! 	<ul style="list-style-type: none"> ● Strom vor Wartungsarbeiten abschalten! (Netzstrom völlig öffnen; Maschine anhalten!) 	<ul style="list-style-type: none"> ● Anlage nie ohne Schutzgehäuse oder Innenschutzverkleidung in Betrieb setzen! 	German WARNUNG
<ul style="list-style-type: none"> ● Mantenha seu rosto da fumaça. ● Use ventilação e exaustão para remover fumo da zona respiratória. 	<ul style="list-style-type: none"> ● Não opere com as tampas removidas. ● Desligue a corrente antes de fazer serviço. ● Não toque as partes elétricas nuas. 	<ul style="list-style-type: none"> ● Mantenha-se afastado das partes moventes. ● Não opere com os painéis abertos ou guardas removidas. 	Portuguese ATENÇÃO
<ul style="list-style-type: none"> ● ヒュームから頭を離すようにして下さい。 ● 換気や排煙に十分留意して下さい。 	<ul style="list-style-type: none"> ● メンテナンス・サービスに取りかかる際には、まず電源スイッチを必ず切して下さい。 	<ul style="list-style-type: none"> ● パネルやカバーを取り外したまま機械操作をしないで下さい。 	Japanese 注意事項
<ul style="list-style-type: none"> ● 頭部遠離煙霧。 ● 在呼吸區使用通風或排風器除煙。 	<ul style="list-style-type: none"> ● 維修前切斷電源。 	<ul style="list-style-type: none"> ● 儀表板打開或沒有安全罩時不準作業。 	Chinese 警告
<ul style="list-style-type: none"> ● 얼굴로부터 용접가스를 멀리하십시오. ● 호흡지역으로부터 용접가스를 제거하기 위해 가스제거기나 통풍기를 사용하십시오. 	<ul style="list-style-type: none"> ● 보수전에 전원을 차단하십시오. 	<ul style="list-style-type: none"> ● 판넬이 열린 상태로 작동치 마십시오. 	Korean 위험
<ul style="list-style-type: none"> ● ابعد رأسك بعيداً عن الدخان. ● استعمل التهوية أو جهاز ضغط الدخان للخارج لكي تبعد الدخان عن المنطقة التي تتنفس فيها. 	<ul style="list-style-type: none"> ● أقطع التيار الكهربائي قبل القيام بأية صيانة. 	<ul style="list-style-type: none"> ● لا تشغيل هذا الجهاز اذا كانت الاغطية الحديدية الواقية ليست عليه. 	Arabic تحذير

LEIA E COMPREENDA AS INSTRUÇÕES DO FABRICANTE PARA ESTE EQUIPAMENTO E AS PARTES DE USO, E SIGA AS PRÁTICAS DE SEGURANÇA DO EMPREGADOR.

使う機械や溶材のメーカーの指示書をよく読み、まず理解して下さい。そして貴社の安全規定に従って下さい。

請詳細閱讀並理解製造廠提供的說明以及應該使用的銀焊材料，並請遵守貴方的有關勞動保護規定。

이 제품에 동봉된 작업지침서를 숙지하시고 귀사의 작업자 안전수칙을 준수하시기 바랍니다.

اقرأ بتمعن وافهم تعليمات المصنع المنتج لهذه المعدات والمواد قبل استعمالها واتبع تعليمات الوقاية لصاحب العمل.

CUSTOMER ASSISTANCE POLICY

The business of Lincoln Electric is manufacturing and selling high quality welding equipment, automated welding systems, consumables, and cutting equipment. Our challenge is to meet the needs of our customers, who are experts in their fields, and to exceed their expectations. On occasion, purchasers may ask Lincoln Electric for information or technical information about their use of our products. Our employees respond to inquiries to the best of their ability based on information and specifications provided to them by the customers and the knowledge they may have concerning the application. Our employees, however, are not in a position to verify the information provided or to evaluate the engineering requirements for the particular weldment, or to provide engineering advice in relation to a specific situation or application. Accordingly, Lincoln Electric does not warrant or guarantee or assume any liability with respect to such information or communications. Moreover, the provision of such information or technical information does not create, expand, or alter any warranty on our products. Any express or implied warranty that might arise from the information or technical information, including any implied warranty of merchantability or any warranty of fitness for any customers' particular purpose or any other equivalent or similar warranty is specifically disclaimed.

Lincoln Electric is a responsive manufacturer, but the definition of specifications, and the selection and use of specific products sold by Lincoln Electric is solely within the control of, and remains the sole responsibility of the customer. Many variables beyond the control of Lincoln Electric affect the results obtained in applying these types of fabrication methods and service requirements.



THE LINCOLN ELECTRIC COMPANY

22801 St. Clair Avenue • Cleveland, OH • 44117-1199 • U.S.A.
Phone: +1.216.481.8100 • www.lincolnelectric.com