

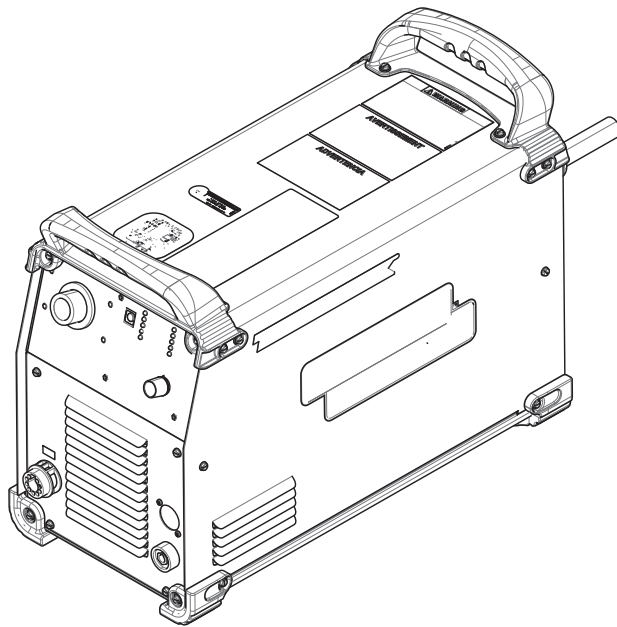

Operator's Manual

Tomahawk[®] 1500



For use with machines having Code Numbers:
12549, 12588, 12922



Register your machine:

www.lincolnelectric.com/register

Authorized Service and Distributor Locator:

www.lincolnelectric.com/locator

Save for future reference

Date Purchased

Code: (ex: 10859)

Serial: (ex: U1060512345)

THANK YOU FOR SELECTING A QUALITY PRODUCT BY LINCOLN ELECTRIC.

PLEASE EXAMINE CARTON AND EQUIPMENT FOR DAMAGE IMMEDIATELY

When this equipment is shipped, title passes to the purchaser upon receipt by the carrier. Consequently, claims for material damaged in shipment must be made by the purchaser against the transportation company at the time the shipment is received.

SAFETY DEPENDS ON YOU

Lincoln arc welding and cutting equipment is designed and built with safety in mind. However, your overall safety can be increased by proper installation ... and thoughtful operation on your part. **DO NOT INSTALL, OPERATE OR REPAIR THIS EQUIPMENT WITHOUT READING THIS MANUAL AND THE SAFETY PRECAUTIONS CONTAINED THROUGHOUT.** And, most importantly, think before you act and be careful.

WARNING

This statement appears where the information must be followed exactly to avoid serious personal injury or loss of life.

CAUTION

This statement appears where the information must be followed to avoid minor personal injury or damage to this equipment.



KEEP YOUR HEAD OUT OF THE FUMES.

DON'T get too close to the arc. Use corrective lenses if necessary to stay a reasonable distance away from the arc.

READ and obey the Safety Data Sheet (SDS) and the warning label that appears on all containers of welding materials.

USE ENOUGH VENTILATION or exhaust at the arc, or both, to keep the fumes and gases from your breathing zone and the general area.

IN A LARGE ROOM OR OUTDOORS, natural ventilation may be adequate if you keep your head out of the fumes (See below).

USE NATURAL DRAFTS or fans to keep the fumes away from your face.

If you develop unusual symptoms, see your supervisor. Perhaps the welding atmosphere and ventilation system should be checked.

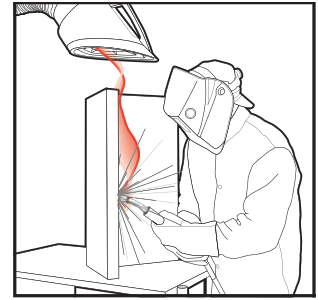

WEAR CORRECT EYE, EAR & BODY PROTECTION

PROTECT your eyes and face with welding helmet properly fitted and with proper grade of filter plate (See ANSI Z49.1).

PROTECT your body from welding spatter and arc flash with protective clothing including woolen clothing, flame-proof apron and gloves, leather leggings, and high boots.

PROTECT others from splatter, flash, and glare with protective screens or barriers.

IN SOME AREAS, protection from noise may be appropriate.

BE SURE protective equipment is in good condition.

Also, wear safety glasses in work area **AT ALL TIMES.**



SPECIAL SITUATIONS

DO NOT WELD OR CUT containers or materials which previously had been in contact with hazardous substances unless they are properly cleaned. This is extremely dangerous.

DO NOT WELD OR CUT painted or plated parts unless special precautions with ventilation have been taken. They can release highly toxic fumes or gases.

Additional precautionary measures

PROTECT compressed gas cylinders from excessive heat, mechanical shocks, and arcs; fasten cylinders so they cannot fall.

BE SURE cylinders are never grounded or part of an electrical circuit.

REMOVE all potential fire hazards from welding area.

ALWAYS HAVE FIRE FIGHTING EQUIPMENT READY FOR IMMEDIATE USE AND KNOW HOW TO USE IT.



SECTION A: WARNINGS



CALIFORNIA PROPOSITION 65 WARNINGS



WARNING: Breathing diesel engine exhaust exposes you to chemicals known to the State of California to cause cancer and birth defects, or other reproductive harm.

- Always start and operate the engine in a well-ventilated area.
- If in an exposed area, vent the exhaust to the outside.
- Do not modify or tamper with the exhaust system.
- Do not idle the engine except as necessary.

For more information go to www.P65warnings.ca.gov/diesel

WARNING: This product, when used for welding or cutting, produces fumes or gases which contain chemicals known to the State of California to cause birth defects and, in some cases, cancer. (California Health & Safety Code § 25249.5 *et seq.*)



WARNING: Cancer and Reproductive Harm
www.P65warnings.ca.gov

ARC WELDING CAN BE HAZARDOUS. PROTECT YOURSELF AND OTHERS FROM POSSIBLE SERIOUS INJURY OR DEATH. KEEP CHILDREN AWAY. PACEMAKER WEARERS SHOULD CONSULT WITH THEIR DOCTOR BEFORE OPERATING.

Read and understand the following safety highlights. For additional safety information, it is strongly recommended that you purchase a copy of "Safety in Welding & Cutting - ANSI Standard Z49.1" from the American Welding Society, P.O. Box 351040, Miami, Florida 33135 or CSA Standard W117.2-1974. A Free copy of "Arc Welding Safety" booklet E205 is available from the Lincoln Electric Company, 22801 St. Clair Avenue, Cleveland, Ohio 44117-1199.

BE SURE THAT ALL INSTALLATION, OPERATION, MAINTENANCE AND REPAIR PROCEDURES ARE PERFORMED ONLY BY QUALIFIED INDIVIDUALS.



FOR ENGINE POWERED EQUIPMENT.

- 1.a. Turn the engine off before troubleshooting and maintenance work unless the maintenance work requires it to be running.
- 1.b. Operate engines in open, well-ventilated areas or vent the engine exhaust fumes outdoors.
- 1.c. Do not add the fuel near an open flame welding arc or when the engine is running. Stop the engine and allow it to cool before refueling to prevent spilled fuel from vaporizing on contact



with hot engine parts and igniting. Do not spill fuel when filling tank. If fuel is spilled, wipe it up and do not start engine until fumes have been eliminated.

- 1.d. Keep all equipment safety guards, covers and devices in position and in good repair. Keep hands, hair, clothing and tools away from V-belts, gears, fans and all other moving parts when starting, operating or repairing equipment.
- 1.e. In some cases it may be necessary to remove safety guards to perform required maintenance. Remove guards only when necessary and replace them when the maintenance requiring their removal is complete. Always use the greatest care when working near moving parts.
- 1.f. Do not put your hands near the engine fan. Do not attempt to override the governor or idler by pushing on the throttle control rods while the engine is running.
- 1.g. To prevent accidentally starting gasoline engines while turning the engine or welding generator during maintenance work, disconnect the spark plug wires, distributor cap or magneto wire as appropriate.
- 1.h. To avoid scalding, do not remove the radiator pressure cap when the engine is hot.



ELECTRIC AND MAGNETIC FIELDS MAY BE DANGEROUS



- 2.a. Electric current flowing through any conductor causes localized Electric and Magnetic Fields (EMF). Welding current creates EMF fields around welding cables and welding machines
- 2.b. EMF fields may interfere with some pacemakers, and welders having a pacemaker should consult their physician before welding.
- 2.c. Exposure to EMF fields in welding may have other health effects which are now not known.
- 2.d. All welders should use the following procedures in order to minimize exposure to EMF fields from the welding circuit:
 - 2.d.1. Route the electrode and work cables together - Secure them with tape when possible.
 - 2.d.2. Never coil the electrode lead around your body.
 - 2.d.3. Do not place your body between the electrode and work cables. If the electrode cable is on your right side, the work cable should also be on your right side.
 - 2.d.4. Connect the work cable to the workpiece as close as possible to the area being welded.
 - 2.d.5. Do not work next to welding power source.



ELECTRIC SHOCK CAN KILL.



- 3.a. The electrode and work (or ground) circuits are electrically “hot” when the welder is on. Do not touch these “hot” parts with your bare skin or wet clothing. Wear dry, hole-free gloves to insulate hands.
- 3.b. Insulate yourself from work and ground using dry insulation. Make certain the insulation is large enough to cover your full area of physical contact with work and ground.

In addition to the normal safety precautions, if welding must be performed under electrically hazardous conditions (in damp locations or while wearing wet clothing; on metal structures such as floors, gratings or scaffolds; when in cramped positions such as sitting, kneeling or lying, if there is a high risk of unavoidable or accidental contact with the workpiece or ground) use the following equipment:

- Semiautomatic DC Constant Voltage (Wire) Welder.
 - DC Manual (Stick) Welder.
 - AC Welder with Reduced Voltage Control.
- 3.c. In semiautomatic or automatic wire welding, the electrode, electrode reel, welding head, nozzle or semiautomatic welding gun are also electrically “hot”.
 - 3.d. Always be sure the work cable makes a good electrical connection with the metal being welded. The connection should be as close as possible to the area being welded.
 - 3.e. Ground the work or metal to be welded to a good electrical (earth) ground.
 - 3.f. Maintain the electrode holder, work clamp, welding cable and welding machine in good, safe operating condition. Replace damaged insulation.
 - 3.g. Never dip the electrode in water for cooling.
 - 3.h. Never simultaneously touch electrically “hot” parts of electrode holders connected to two welders because voltage between the two can be the total of the open circuit voltage of both welders.
 - 3.i. When working above floor level, use a safety belt to protect yourself from a fall should you get a shock.
 - 3.j. Also see Items 6.c. and 8.



ARC RAYS CAN BURN.



- 4.a. Use a shield with the proper filter and cover plates to protect your eyes from sparks and the rays of the arc when welding or observing open arc welding. Headshield and filter lens should conform to ANSI Z87.1 standards.
- 4.b. Use suitable clothing made from durable flame-resistant material to protect your skin and that of your helpers from the arc rays.
- 4.c. Protect other nearby personnel with suitable, non-flammable screening and/or warn them not to watch the arc nor expose themselves to the arc rays or to hot spatter or metal.



FUMES AND GASES CAN BE DANGEROUS.



- 5.a. Welding may produce fumes and gases hazardous to health. Avoid breathing these fumes and gases. When welding, keep your head out of the fume. Use enough ventilation and/or exhaust at the arc to keep fumes and gases away from the breathing zone. **When welding hardfacing (see instructions on container or SDS) or on lead or cadmium plated steel and other metals or coatings which produce highly toxic fumes, keep exposure as low as possible and within applicable OSHA PEL and ACGIH TLV limits using local exhaust or mechanical ventilation unless exposure assessments indicate otherwise. In confined spaces or in some circumstances, outdoors, a respirator may also be required. Additional precautions are also required when welding on galvanized steel.**
- 5.b. The operation of welding fume control equipment is affected by various factors including proper use and positioning of the equipment, maintenance of the equipment and the specific welding procedure and application involved. Worker exposure level should be checked upon installation and periodically thereafter to be certain it is within applicable OSHA PEL and ACGIH TLV limits.
- 5.c. Do not weld in locations near chlorinated hydrocarbon vapors coming from degreasing, cleaning or spraying operations. The heat and rays of the arc can react with solvent vapors to form phosgene, a highly toxic gas, and other irritating products.
- 5.d. Shielding gases used for arc welding can displace air and cause injury or death. Always use enough ventilation, especially in confined areas, to insure breathing air is safe.
- 5.e. Read and understand the manufacturer’s instructions for this equipment and the consumables to be used, including the Safety Data Sheet (SDS) and follow your employer’s safety practices. SDS forms are available from your welding distributor or from the manufacturer.
- 5.f. Also see item 1.b.



WELDING AND CUTTING SPARKS CAN CAUSE FIRE OR EXPLOSION.

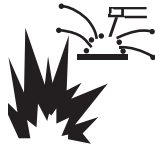

- 6.a. Remove fire hazards from the welding area. If this is not possible, cover them to prevent the welding sparks from starting a fire. Remember that welding sparks and hot materials from welding can easily go through small cracks and openings to adjacent areas. Avoid welding near hydraulic lines. Have a fire extinguisher readily available.
- 6.b. Where compressed gases are to be used at the job site, special precautions should be used to prevent hazardous situations. Refer to "Safety in Welding and Cutting" (ANSI Standard Z49.1) and the operating information for the equipment being used.
- 6.c. When not welding, make certain no part of the electrode circuit is touching the work or ground. Accidental contact can cause overheating and create a fire hazard.
- 6.d. Do not heat, cut or weld tanks, drums or containers until the proper steps have been taken to insure that such procedures will not cause flammable or toxic vapors from substances inside. They can cause an explosion even though they have been "cleaned". For information, purchase "Recommended Safe Practices for the Preparation for Welding and Cutting of Containers and Piping That Have Held Hazardous Substances", AWS F4.1 from the American Welding Society (see address above).
- 6.e. Vent hollow castings or containers before heating, cutting or welding. They may explode.
- 6.f. Sparks and spatter are thrown from the welding arc. Wear oil free protective garments such as leather gloves, heavy shirt, cuffless trousers, high shoes and a cap over your hair. Wear ear plugs when welding out of position or in confined places. Always wear safety glasses with side shields when in a welding area.
- 6.g. Connect the work cable to the work as close to the welding area as practical. Work cables connected to the building framework or other locations away from the welding area increase the possibility of the welding current passing through lifting chains, crane cables or other alternate circuits. This can create fire hazards or overheat lifting chains or cables until they fail.
- 6.h. Also see item 1.c.
- 6.i. Read and follow NFPA 51B "Standard for Fire Prevention During Welding, Cutting and Other Hot Work", available from NFPA, 1 Batterymarch Park, PO box 9101, Quincy, MA 022690-9101.
- 6.j. Do not use a welding power source for pipe thawing.



CYLINDER MAY EXPLODE IF DAMAGED.



- 7.a. Use only compressed gas cylinders containing the correct shielding gas for the process used and properly operating regulators designed for the gas and pressure used. All hoses, fittings, etc. should be suitable for the application and maintained in good condition.
- 7.b. Always keep cylinders in an upright position securely chained to an undercarriage or fixed support.
- 7.c. Cylinders should be located:
 - Away from areas where they may be struck or subjected to physical damage.
 - A safe distance from arc welding or cutting operations and any other source of heat, sparks, or flame.
- 7.d. Never allow the electrode, electrode holder or any other electrically "hot" parts to touch a cylinder.
- 7.e. Keep your head and face away from the cylinder valve outlet when opening the cylinder valve.
- 7.f. Valve protection caps should always be in place and hand tight except when the cylinder is in use or connected for use.
- 7.g. Read and follow the instructions on compressed gas cylinders, associated equipment, and CGA publication P-1, "Precautions for Safe Handling of Compressed Gases in Cylinders," available from the Compressed Gas Association, 14501 George Carter Way Chantilly, VA 20151.



FOR ELECTRICALLY POWERED EQUIPMENT.



- 8.a. Turn off input power using the disconnect switch at the fuse box before working on the equipment.
- 8.b. Install equipment in accordance with the U.S. National Electrical Code, all local codes and the manufacturer's recommendations.
- 8.c. Ground the equipment in accordance with the U.S. National Electrical Code and the manufacturer's recommendations.

Refer to
<http://www.lincolnelectric.com/safety>
for additional safety information.

SAFETY

General Precautions

Whereas plasma cutting has been used safely for years, it does require certain precautions to ensure the safety of the operator and other people around the equipment. The following safety information must be provided to each person who will operate, observe, perform maintenance, or work in close proximity to this piece of equipment.

Installation, operation, and repairs made to the system should only be performed by qualified personnel. The system makes use of both A.C. and D.C. circuitry for operation. Fatal shock hazard does exist. Exercise extreme caution while working on the system. Safety decals On the power supply should not be removed.



ULTRAVIOLET RADIATION PROTECTION

Plasma cutting produces ultraviolet radiation similar to a welding arc. This ultraviolet radiation can cause skin and eye burns. For this reason, it is essential that proper protection be worn. The eyes are best protected by using safety glasses or a welding helmet with an AWS No. 12 shade or ISO 4850 No. 13 shade, which provides protection up to 400 amperes. All exposed skin areas should be covered with flame-retardant clothing. The cutting area should also be prepared in such a way that ultraviolet light does not reflect. Walls and other surfaces should be painted with dark colors to reduce reflected light. Protective screens or curtains should be installed to protect additional workers in the area from ultraviolet radiation.



NOISE PROTECTION

The system generates high noise levels while cutting. Depending on the size of the cutting area, distance from the cutting torch, and arc current cutting level, acceptable noise levels may be exceeded. Proper ear protection should be used as defined by local or national codes.



TOXIC FUME PREVENTION

Care should be taken to ensure adequate ventilation in the cutting area. Some materials give off toxic fumes that can be harmful or fatal to people in the vicinity of the cutting area. Also, some solvents decompose and form harmful gases when exposed to ultraviolet radiation. These solvents should be removed from the area prior to cutting. Galvanized metal can produce harmful gases during the cutting process. Ensure proper ventilation and use breathing equipment when cutting these materials.

Certain metals coated with or containing lead, cadmium, zinc, beryllium, and mercury produce harmful toxins. Do not cut these metals unless all people subjected to the fumes wear proper air breathing equipment.



ELECTRIC SHOCK PREVENTION

The system uses high open circuit voltages that can be fatal. Extreme care should be used when operating or performing maintenance on the system.

Only qualified personnel should service the system. Observe the following guidelines to protect against electric shock:

- A wall-mounted disconnect switch should be installed and fused according to local and national electrical codes. The disconnect switch should be located as close as possible to the power supply so it can be turned off in case of an emergency.
- The primary power cord should have a 600 volt minimum rating in order to protect the operator. In addition, it should be sized according to local and national electrical codes. Inspect the primary power cord frequently. Never operate the system if the power cord is damaged in any way.
- Make sure the primary power ground wire is connected at the input power ground location on the power supply. Make sure the connection is securely tightened.
- Make sure the positive output (work ground) of the power supply is connected to a bare metal area on the cutting table. A driven ground rod should be placed no further than five feet from this connection. Make sure this ground point on the cutting table is used as the star ground point for all other ground connections.
- Inspect the torch leads frequently. Never use the system if the leads are damaged in any way.
- Do not stand in wet, damp areas when operating or performing maintenance on the system.
- Wear insulated gloves and shoes while operating or performing maintenance on the system.
- Make sure the system is switched off at the wall disconnect before servicing the power supply or torch.
- Never change torch consumable parts unless main power to the system is switched off at the power supply or wall disconnect.
- Do not attempt to remove any parts from beneath the torch when cutting. Remember that the workpiece forms the current path back to the power supply.
- Never bypass the safety interlock devices.
- Before removing any of the covers, switch the system off at the wall disconnect. Wait at least five (5) minutes before removing any cover. This will give the capacitors inside the unit time to discharge. See Section 5 for additional safety precautions.
- Never operate the system without all of the covers in place. See Section 5 for additional safety precautions.
- Preventive maintenance should be performed daily to avoid possible safety hazards.



FIRE PREVENTION

When using the system, it is necessary to exercise good judgment. While cutting, the arc produces sparks that could cause a fire if they fall on flammable materials. Make sure that all flammable materials are a suitable distance away from the cutting area. All flammable liquids should be at least 40 feet away from the cutting area, preferably stored in a metal cabinet. Plasma cutting should never be attempted on containers that contain flammable materials. Make sure that fire extinguishers are readily accessible in the cutting area.



EXPLOSION PREVENTION

The system uses compressed gases. Use proper techniques when handling compressed gas cylinders and other compressed gas equipment. Observe the following guidelines to protect against explosion:

- Never operate the system in the presence of explosive gases or other explosive materials.
- Never cut pressurized cylinders or any closed container.
- When using a water table and cutting aluminum under water or with water touching the underside at the aluminum plate, hydrogen gas is produced. This hydrogen gas may collect under the plate and explode during the cutting process. Make sure the water table is properly aerated to help prevent the accumulation of hydrogen gas.
- Handle all gas cylinders in accordance with safety standards published by the U.S. Compressed Gas Association (CGA), American Welding Society (AWS), Canadian Standards Association (CSA), or other local or national codes.
- Compressed gas cylinders should be maintained properly. Never attempt to use a cylinder that is leaking, cracked, or has other signs of physical damage.
- All gas cylinders should be secured to a wall or rack to prevent accidental knock over.
- If a compressed gas cylinder is not being used, replace the protective valve cover.
- Never attempt to repair compressed gas cylinders.
- Keep compressed gas cylinders away from intense heat, sparks, or flames.
- Clear the compressed gas cylinder connection point by opening the valve momentarily prior to installing a regulator.
- Never lubricate compressed gas cylinder valves or pressure regulators with any type of oil or grease.
- Never use a compressed gas cylinder or pressure regulator for any purpose other than which it is intended.
- Never use a pressure regulator for any gas other than which it is intended.
- Never use a pressure regulator that is leaking or has other signs of physical damage.
- Never use any gas hose that is leaking or has other signs of physical damage.



HEALTH SUPPORT EQUIPMENT

The system creates electric and magnetic fields that may interfere with certain types of health support equipment, such as pacemakers. Any person who uses a pacemaker or similar item should consult a doctor before operating, observing, maintaining, or servicing the system. Observe the following guidelines to minimize exposure to these electric and magnetic fields:

- Stay as far away from the ~power supply, torch, and torch leads as possible.
- Route the torch leads as close as possible to the work ground cable.
- Never place your body between the torch leads and work ground cable. Keep the work ground cable and the torch leads on the same side of your body.
- Never stand in the center of a coiled up set of torch leads or work ground cable.

Safety Standards Booklet Index

For further information concerning safety practices to be exercised with plasma arc cutting equipment, please refer to the following publications:

1. AWS Standard AWN, Arc Welding and Cutting Noise, obtainable from the American Welding Society, 550 NW LeJeune Road, Miami, FL 33126.
2. AWS Standard C5.2, Recommended Practices for Plasma Arc Cutting, obtainable from the American Welding Society, 550 NW LeJeune Road, Miami, FL 33126.
3. AWS Standard FSW, Fire Safety in Welding and Cutting, obtainable from the American Welding Society, 550 NW LeJeune Road, Miami, FL 33126.
4. AWS Standard F4.1, Recommended Safe Practices for Preparation for Welding and Cutting of Containers and Piping, obtainable from the American Welding Society, 550 NW LeJeune Road, Miami, FL 33126.
5. AWS Standard ULR, Ultraviolet Reflectance of Paint, obtainable from the American Welding Society, 550 NW LeJeune Road, Miami, FL 33126.
6. AWS I ANSI Standard Z49.1, Safety in Welding, Cutting, and Allied Processes, obtainable from the American Welding Society, 550 NW LeJeune Road, Miami, FL 33126.
7. ANSI Standard Z41.1, Standard For Men's Safety-Toe Footwear, obtainable from the American National Standards Institute, 11 West 42nd Street, New York, NY 10036.
8. ANSI Standard Z49.2, Fire Prevention in the Use of Cutting and Welding Processes, obtainable from the American National Standards Institute, 11 West 42nd Street, New York, NY 10036.
9. ANSI Standard Z87.1, Safe Practices For Occupation and Educational Eye and Face Protection, obtainable from the American National Standards Institute, 11 West 42nd Street, New York, NY 10036.
10. ANSI Standard Z88.2, Respiratory Protection, obtainable from the American National Standards Institute, 11 West 42nd Street, New York, NY 10036.
11. OSHA Standard 29CFR 1910.252, Safety and Health Standards, obtainable from the U.S. Government Printing Office, Washington, D.C. 20402.
12. NFPA Standard 51, Oxygen - Fuel Gas Systems for Welding, Cutting, and Allied Processes, obtainable from the National Fire Protection Association, 1 Batterymarch Park, Quincy, MA 02269.
13. NFPA Standard 51 B, Cutting and Welding Processes, obtainable from the National Fire Protection Association, 1 Batterymarch Park, Quincy, MA 02269.
14. NFPA Standard 70, National Electrical Code, obtainable from the National Fire Protection Association, 1 Batterymarch Park, Quincy, MA 02269.
15. CGA booklet P-1, Safe Handling of Compressed Gases in Containers, obtainable from the Compressed Gas Association, 1725 Jefferson Davis Highway, Suite 1004, Arlington, VA 22202.
16. CGA booklet P-14, Accident Prevention in Oxygen-Rich and Oxygen-Deficient Atmospheres, obtainable from the Compressed Gas Association, 1725 Jefferson Davis Highway, Suite 1004, Arlington, VA 22202.
17. CGA booklet TB-3, Hose Line Flashback Arrestors, obtainable from the Compressed Gas Association, 1725 Jefferson Davis Highway, Suite 1004, Arlington, VA 22202.
18. CSA Standard W117.2, Safety in Welding, Cutting, and Allied Processes, obtainable from Canadian Standards Association, 178 Rexdale Boulevard, Toronto, Ontario M9W 1R3, Canada.
19. Canadian Electrical Code Part 1, Safety Standard for Electrical Installations, obtainable from the Canadian Standards Association, 178 Rexdale Boulevard, Toronto, Ontario M9W 1R3, Canada.

Table Of Contents

Page

General Description
Preheat Temperature For Plasma Cutting	6
Duty Cycle.....	6
User Responsibility.....	6
Design Features And Advantages	6
Installation	Section A
Select Suitable Location.....	A-1
Lifting	A-2
Stacking	A-2
Tilting	A-2
High Frequency Interference Protection	A-2
Input Connection.....	A-2
Machine Grounding.....	A-2
Input Plug Installation	A-3
Power Cord Replacement.....	A-3
Engine Driven Generator	A-3
Gas Supply Requirements.....	A-3
Connecting The Gas Supply	A-4
Output Connections	A-4
Operation	Section B
Controls And Settings	B-2
Hand Cutting	B-4
Mild Steel Cut Chart.....	B-9
Aluminum Cut Chart	B-10
Stainless Steel Cut Chart	B-11
Options/Accessories	Section C
Maintenance	Section D
Daily Procedures	D-1
Monthly Procedures.....	D-1
Troubleshooting	Section E
Wiring Diagrams.....	Section F
Wiring Diagram	F-1
Dimension Print.....	F-2
Parts List	parts.lincolnelectric.com

Content/details may be changed or updated without notice. For most current Instruction Manuals, go to parts.lincolnelectric.com.

GENERAL DESCRIPTION

The Tomahawk® 1500 is a constant current, continuous control plasma cutting power source. It provides superior and reliable starting characteristics, cutting visibility and arc stability. The control system has a safety mechanism to insure that the nozzle and electrode are in place before cutting or gouging. This is extremely important due to the high voltages involved.

The Tomahawk® 1500 comes standard with an air regulator and pressure gauge. The machine also comes with an input power cord. Torches and consumables are included with Tomahawk® 1500 One-Paks®, so that cutting can begin right out of the box. Consumables and torches can also be ordered as individual packages.

The Tomahawk® 1500 initiates the plasma arc with a simple, yet reliable, contact start mechanism. This system eliminates many of the failure problems associated with hi-frequency start systems.

PREHEAT TEMPERATURE FOR PLASMA CUTTING

Preheat temperature control is not necessary in most applications when plasma arc cutting or gouging. Preheat temperature control may be necessary on high carbon alloy steels and heat treated aluminum for crack resistance and hardness control. Job conditions, prevailing codes, alloy level, and other considerations may also require preheat temperature control. The following minimum preheat temperature is recommended as a starting point. Higher temperatures may be used as required by the job conditions and/or prevailing codes. If cracking or excessive hardness occurs on the cut face, higher preheat temperature may be required. The recommended minimum preheat temperature for plate thickness up to 1/2" (12.7mm) is 70°F (21.1°C).

DUTY CYCLE

The duty cycle of a plasma machine is the percentage of time in a 10 minute cycle at which the operator can operate the machine at rated cutting current.

Example: 80% duty cycle means that it is possible to cut for 8 minutes, followed by 2 minutes of machine idling.

Refer to the Technical Specification section for more information about the machine rated duty cycles.

USER RESPONSIBILITY

Because design, fabrication, erection and cutting variables affect the results obtained in applying this type of information, the serviceability of a product or structure is the responsibility of the user. Variation such as plate chemistry, plate surface condition (oil, scale), plate thickness, preheat, quench, gas type, gas flow rate and equipment may produce results different than those expected. Some adjustments to procedures may be necessary to compensate for unique individual conditions. Test all procedures duplicating actual field conditions.

DESIGN FEATURES AND ADVANTAGES

The Tomahawk® 1500 design makes plasma cutting uncomplicated. This list of design features and advantages will help you understand the machine's total capabilities so that you can get maximum use from your machine.

- Light weight and portable design for industrial use.
- Continuous control, 25 - 100 amps.
- Reliable touch start mechanism for plasma arc initiation.
- Rapid arc restrike for fast cutting of expanded metal.
- Input over voltage protection.
- Bright 5.0 second timed pilot arc.
- Gas purge selection.
- Air regulator and pressure gage included.
- Internal water separator included.
- Parts-in-Place mechanism to detect proper installation of consumables and torch.
- Preflow/Postflow timing. Preflow is eliminated if arc is re-initiated in Postflow.
- Thermostatic Protection.
- Solid state over-current protection.
- Patented electrode, nozzle and shield cap for optimum cooling, cut quality and long life.

TECHNICAL SPECIFICATIONS - K2809-1 Tomahawk® 1500

INPUT - SINGLE PHASE/THREE PHASE/ 50 / 60 HERTZ			
Input Voltage +/- 10%	Input Amperes @ Rated Output		Circuit Breaker (Delay Type)
200V/208V/1/50/60	71	80% Duty Cycle	80 Amps
	52	100% Duty Cycle	60 Amps
230V/1/50/60	62	80% Duty Cycle	70 Amps
	48	100% Duty Cycle	50 Amps
200V/208V/3/50/60	49	60% Duty Cycle	50 Amps
	41	80% Duty Cycle	
	31	100% Duty Cycle	
230V/3/50/60	43	60% Duty Cycle	50 Amps
	37	80% Duty Cycle	
	28	100% Duty Cycle	
400V/3/50/60	27	60% Duty Cycle	30 Amps
	21	80% Duty Cycle	
	16	100% Duty Cycle	
460V/3/50/60	22	60% Duty Cycle	25 Amps
	18	80% Duty Cycle	
	14	100% Duty Cycle	
575V/3/50/60	18	60% Duty Cycle	20 Amps
	14	80% Duty Cycle	
	12	100% Duty Cycle	

RATED OUTPUT AT 40° C		
Duty Cycle	CURRENT	VOLTAGE
100%	60A	140 VDC
80%†	80A	140 VDC
60%*	100A	140 VDC

*60% and 80% Rating is not available on 1~ inputs

† Derated to 60% on 200/208V 1~ input

OUTPUT		
Current Range	Open Circuit Voltage	Pilot Current
25 - 100 Amps	270 VDC	20 Amps

GAS	
REQUIRED GAS FLOW RATE	REQUIRED GAS INLET PRESSURE
300 SCFH min @ 90 PSI (140 SLPM min @ 6.2 bar)	87.0 to 109.0 PSI (6.0 Bar. to 7.5 Bar.)

PHYSICAL DIMENSIONS			
Height	Width	Depth	Weight
17.9 in. (454 mm)	11.8 in. (300 mm)	25.4 in. (645 mm)	96 lbs. (44 kgs)

TEMPERATURE RANGES	
OPERATING TEMPERATURE RANGE	STORAGE TEMPERATURE RANGE
-10°C to +40°C	-25°C to +55°C

RECOMMENDED INPUT WIRE	
For all plasma cutting applications Based on U.S. National Electrical Code Ambient Temperature 30°C or Less	
Input Cord Supplied with Machine	500W, 600V
	Type S, S0, ST, ST0 or Extra Hard Usage Cord AWG (IEC) Sizes
	Input Supply Wires #6 (13.3 mm ²)
	1 Ground Wire #6 (13.3 mm ²)

Read entire Installation Section before installing the Tomahawk® 1500 .

SAFETY PRECAUTIONS

WARNING

ELECTRIC SHOCK CAN KILL.

- Only qualified personnel should install this machine.
- Turn the input power OFF at the disconnect switch or fuse box and discharge input capacitors before working inside the equipment.
- Do not touch electrically hot parts.
- Turn the Tomahawk® 1500 Power Switch OFF when connecting power cord to input power.



SELECT SUITABLE LOCATION

Place the Tomahawk® 1500 where clean cool air can freely circulate in through the rear of the machine and out through the front and side louvers. Maintain at least 10 inches of space on all sides of the unit. Dirt, dust, or any foreign material that be drawn into the machine should be kept to a minimum. A properly installed machine will allow for dependable service and reduce periodic maintenance time. Failure to observe these precautions may result in excessive operating temperatures and nuisance shutdowns of the machine.

LIFTING

The Tomahawk® 1500 power supply should be lifted by two people or a hoist. In order to prevent damage, the power supply should be lifted by both handles while keeping the unit as horizontal as possible. Only hoisting straps approved for the weight of the machine should be used.

STACKING

The Tomahawk® 1500 **cannot** be stacked.

TILTING

The Tomahawk® 1500 must be placed on a stable, level surface so it will not topple over.

HIGH FREQUENCY INTERFERENCE PROTECTION

The Tomahawk® 1500 employs a touch start mechanism for arc initiation which eliminates high frequency emissions from the machine as compared with spark gap and solid state type high frequency generators. Keep in mind though, that these machines may be used in an environment where other high frequency generating machines are operating. By taking the following steps, high frequency interference into the Tomahawk® 1500 can be minimized:

- (1) Make sure the power supply chassis is connected to a good earth ground. The work terminal ground does NOT ground the machine frame.
- (2) Keep the work clamp isolated from other work clamps that have high frequency.
- (3) If the work clamp cannot be isolated, then keep the clamp as far as possible from other work clamp connections.
- (4) When the machine is enclosed in a metal building, several good earth driven grounds around the periphery of the building are recommended.

INPUT CONNECTION

WARNING

Only a qualified electrician should connect the input leads to the Tomahawk® 1500. Connections should be made in accordance with all local and national electrical codes and the connection diagrams. Failure to do so may result in bodily injure or death.



The Tomahawk® 1500 is rated for 208 VAC through 575 VAC input voltages, single or three phase and 50 or 60 Hertz. Before connecting the machine to power, be sure the input supply voltage, phase and frequency all match those listed on the machine's rating plate.

The Tomahawk® 1500 automatically senses and adjusts to work with any input voltage, phase or frequency listed on the rating plate. No reconnect switch settings are required.

MACHINE GROUNDING

The frame of the welder must be grounded. A ground terminal marked with a ground symbol is located next to the input power connection block.



See your local and national electrical codes for proper grounding methods.

WARNING

The Tomahawk® 1500 ON/OFF switch is not intended as a service disconnect for this equipment. Only a qualified electrician should connect the input leads to the Tomahawk 1500. Connections should be made in accordance with all local and national electrical codes. Failure to do so may result in bodily injury or death.

INPUT PLUG INSTALLATION

A 10 ft. (3m) power cord is provided with the Tomahawk® 1500.

Single Phase Input

Connect green lead to ground per National Electrical Code.

Connect black and red leads to power.

Wrap white lead with tape to provide 600V insulation.

Three Phase Input

Connect green lead to ground per National Electric Code.

Connect black, red and white leads to power.

In all cases, the green or green/yellow grounding wire must be connected to the grounding pin of the plug, usually identified by a green screw.

Attachment plugs must comply with the Standard for Attachment Plugs and Receptacles, UL498.

The product is considered acceptable for use only when an attachment plug as specified is properly attached to the supply cord.

POWER CORD REPLACEMENT

WARNING

Only a qualified electrician should connect the input leads to the Tomahawk 1500 Connections should be made in accordance with all local and national electrical codes and the connection diagrams. Failure to do so may result in bodily injury or death.

If the input cord is damaged or needs to be replaced, the new cord must be wired directly into the switch on the back of the machine.

Be sure to disconnect the cord from input power before working on the machine. Remove the sheetmetal wraparound from the machine, loosen the strain relief on the rear of the machine, and loosen the three input screws on the power switch as well as the grounding nut. Remove the old cord and replace as shown below. Be sure to torque the phillips screws on the input power switch and the grounding nut to 18-25 in-lbs.

ALWAYS CONNECT THE GROUNDING LUG (LOCATED INSIDE THE MACHINE) TO A PROPER SAFETY (EARTH) GROUND.

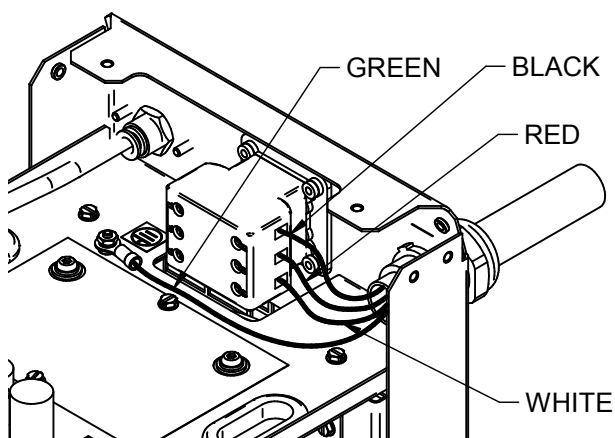

ENGINE DRIVEN GENERATOR

For use on engine drives, keep in mind the above input draw restrictions and the following precaution.

The Tomahawk® 1500 can be operated on engine driven generators as long as the 230 volt auxiliary meets the following conditions:

- The AC waveform peak voltage is below 400 volts.
- The AC waveform frequency is between 45 and 65 Hz.

Lincoln Electric Vantage® and Ranger® engine drives meet these specifications.

Operation of the Tomahawk® 1500 is not recommended on engine drives not conforming to these conditions. Such combinations may overvoltage the Tomahawk® 1500 power source.

GAS SUPPLY REQUIREMENTS

Supply the Tomahawk® 1500 with clean, dry, oil-free compressed air or nitrogen. A high pressure regulator **MUST** be used with a compressor or a high pressure cylinder.

Supply pressure must be between 87-110 psi (6 - 7.6 bar) with flow rates of at least 300 SCFH or 140 SLPM.

WARNING

Air supply pressure should never exceed 110 psi or damage to the machine may occur!

The Tomahawk® 1500 contains a built-in filter but depending on the quality of the supply, additional filtration may be required. Be aware that shop air systems are prone to oil and moisture contamination. If shop air is used, it must be cleaned to ISO 8573-1:2010, Class 1.4.1.

Specify dry air when using compressed cylinders. Breathing quality air contains moisture and should not be used.

A standard nominal 5 micron inline filter is recommended, but for optimal performance, select a pre-filter with a 3 micron absolute rating.

WARNING

CYLINDER could explode if damaged.

- Keep cylinder upright and chained to a fixed support.
- Keep cylinder away from areas where it could be damaged.
- Never lift machine with cylinder attached.
- Never allow the cutting torch to touch the cylinder.
- Keep cylinder away from live electrical parts.
- Maximum inlet pressure 110 psi.



CONNECTING THE GAS SUPPLY

Air or gas must be supplied to the Tomahawk® 1500 with 3/8" inside diameter tubing and a 1/4" NPT quick disconnect coupler.

OUTPUT CONNECTIONS

Torch

The Tomahawk® 1500 is sent from the factory with a work clamp included. The work clamp must be securely connected to the work piece. If the work piece is painted or extremely dirty it may be necessary to expose the bare metal in order to make a good electrical connection.

TOMAHAWK 1500 CUT AND GOUGE CAPACITIES

MAXIMUM OUTPUT CURRENT	
Cut Capacity - Material Thickness	
Recommended cut capacity at 23 ipm	1 in.
Recommended cut capacity at 14 ipm	1-1/4 in.
Severance capacity at 8 ipm	1-1/2 in.
Maximum Cut Speeds - Mild Steel *	
1/4 in.	182 ipm
1/2 in.	71 ipm
3/4 in.	36 ipm
1 in.	23 ipm
1-1/4 in.	14 ipm
Gouge Capacity - Mild Steel	
Metal Removal Rate - 80 Amps	19.08 lbs/hr
Metal Removal Rate - 100 Amps	22.62 lbs/hr

* Maximum cut speeds are based on results obtained from Lincoln Electric's laboratory testing.

Different cutting applications may alter the actual cutting speed.

OPERATION

GRAPHIC SYMBOLS THAT APPEAR ON THIS MACHINE OR IN THIS MANUAL

SAFETY PRECAUTIONS

WARNING

ELECTRIC SHOCK can kill.

- Do not touch electrically live parts or electrode with skin or wet clothing.
- Insulate yourself from work and ground.
- Always wear dry insulating gloves.



FUMES AND GASES can be dangerous.

- Keep your head out of fumes.
- Use ventilation or exhaust to remove fumes from breathing zone.



WELDING, CUTTING and GOUGING SPARKS can cause fire or explosion

- Keep flammable material away.
- Do not weld, cut or gouge on containers that have held combustibles.



ARC RAYS can burn.

- Wear eye, ear and body protection.

















PLASMA ARC can injure

- Keep your body away from nozzle and plasma arc.
- Operate the pilot arc with caution. The pilot arc is capable of burning the operator, others or even piercing safety clothing.



Observe additional Safety Guidelines detailed in the beginning of this manual.

-  **WARNING OR CAUTION**
-  **INPUT VOLTAGE**
-  **OUTPUT ON**
-  **GAS PURGE**
-  **HIGH TEMPERATURE**
-  **READ INSTRUCTION MANUAL**
-  **PROTECTIVE GROUND**
-  **GAS INPUT**
-  **SINGLE PHASE**
-  **CUT**
-  **CONTINUOUS PILOT**
-  **GOUGE**
-  **POWER ON**
-  **POWER OFF**
-  **PARTS IN PLACE - CONSUMABLES MISSING OR LOOSE**

CONTROLS AND SETTINGS

FIGURE B.2 Tomahawk® 1500 front command panel.

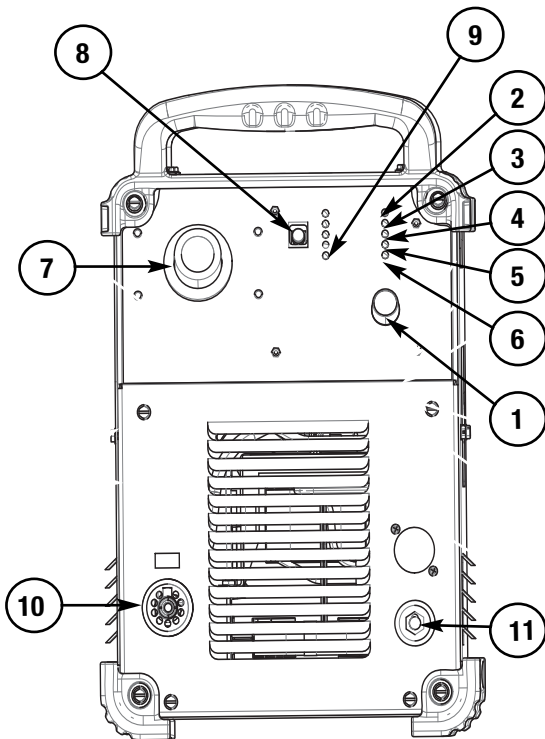

When the machine is turned ON, an auto-test is executed; during this test all of the LEDs on the Control Panel light up.

1. Output Current Knob: For setting the output current used during cutting. Refer to the Technical Specification section for more information about the machine's rated current range.

Air, Gas Purge: The Output Current Knob completely rotated counterclockwise enables the air purge function.

2. Power ON/OFF green LED: Illuminates when the machine is ON.

Blinking: Input voltage out of range condition. The machine is disabled: When the input voltage returns to the correct range, the machine will restart automatically.

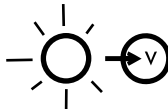

Note: The Fan may automatically turn OFF if the error condition persists for more than 2 seconds.

3. Output red LED: The cutting torch is energized.

Blinking: Internal auxiliary undervoltage condition. The machine needs to be turned OFF then ON again to restart.

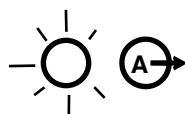

4. Thermal yellow LED: The machine is overheated and the output has been disabled. This usually occurs when the duty cycle of the machine has been exceeded. Leave the machine ON to allow the internal components to cool. When the thermal LED turns off, normal operation is again possible.



5. Gas Pressure yellow LED: The Input Gas pressure is out of range. The machine will restart automatically when a correct gas pressure is detected.



To check/adjust the primary gas pressure (see recommended values in the Technical Specifications of this manual):

- When this LED illuminates, the machine will automatically enter into Purge mode for 10 seconds.
- During Purge time verify and adjust the gas pressure using the gas pressure regulator knob.
- If necessary, also verify and adjust the inlet gas pressure to the unit.

6. Parts In Place (PIP) yellow LED: Torch consumables are not attached correctly.



To reset the machine:

- Firmly attach the torch shielding Cup by hand. Do not over tighten.
- After the torch is restored, the machine will restart after 5 seconds. During this time the PIP LED will blink.
- Note:** When the LED is blinking, if another PIP error occurs or if the Torch Trigger pushbutton is pressed the machine will return to the error condition: PIP LED returns to steady ON and the restoring procedure repeats.
- When the PIP LED turns OFF the machine is ready to operate.

7. Primary Air, Gas Pressure Gauge and Regulator Knob: Allows the regulation and monitoring of the primary air/gas pressure.

The inlet primary air/gas pressure is limited by this pressure regulator, set at the factory to 80 PSI (5.5 bar). To adjust the air/gas pressure, place the machine in Purge mode. Pull out on regulator knob and turn to adjust.

8. Cutting Operating Mode Selection: Press the pushbutton to select the desired operating mode (the LED indicates the selected mode):

- CUT (Upper LED): for cutting or piercing operations on a solid work piece.
- GRID (Middle LED): for cutting operations on a grid work piece.
- GOUGE (Lower LED): for removing material from a solid work piece (removing a weld).



The Operating Mode can only be changed with the machine at idle or during Purge or Post Flow times. Pressing the pushbutton during Pilot Arc or Cutting will have no effect.

9. Single phase LED:

Single phase power is connected to the machine. Maximum output current limited to 80 amps.

10. Torch Connection:

Connect handheld torch.

11. Work Connection:

Connect cable with work clamp.

Items 12 thru 15 on the back of the Tomahawk® 1500 (See Figure B.3)

12. Fan: Provides machine cooling. When the machine is switched ON, the fan runs continuously.

13. Power Switch:

Turns the input power to the machine ON/OFF.

14. Input Cord (10 ft.):

Connects the unit to input power.

15. Air or Gas Inlet (1/4" NPT Quick Connect):

Compressed air or gas connection.

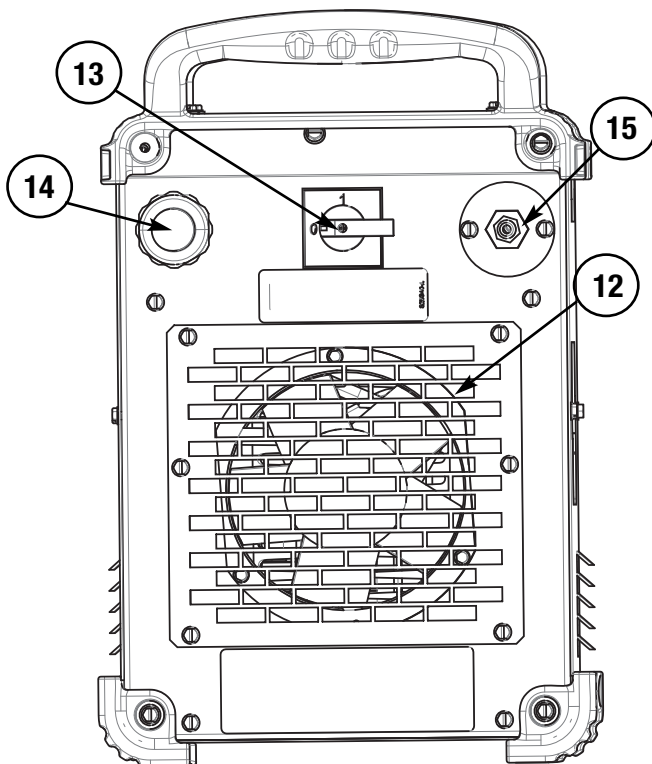
FIGURE B.3

HAND CUTTING

TORCH PART CONFIGURATIONS

Different hand held torch configurations are available depending on the cutting or gouging application.

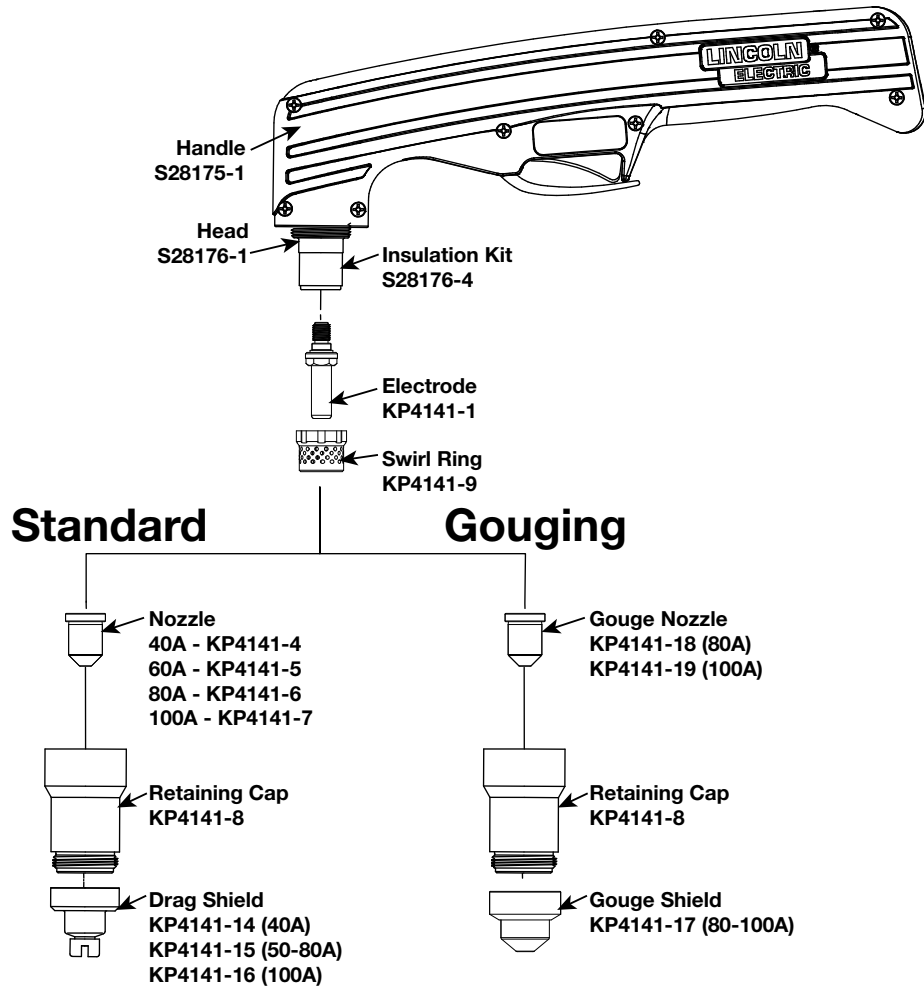

The Tomahawk 1500 is designed for Shielded contact. A special insulated nozzle is used in conjunction with a special drag shield. Shielded contact set-ups are for applications greater than 40 amps.

Shielded Contact

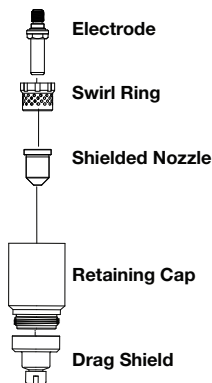

Gouging Setup:

If gouging metal and not cutting completely through the part is required, a special gouging nozzle is used in conjunction with a gouge shield to protect the nozzle from molten metal blow back.

Refer to the torch parts decal located on your machine or the parts pages at the back of this manual for the specific part numbers required for each of these setups.

ALWAYS USE GENUINE LINCOLN ELECTRIC ELECTRODES, NOZZLES, AND EXPENDABLE PARTS FOR THE BEST CUTTING PERFORMANCE.

Gouging

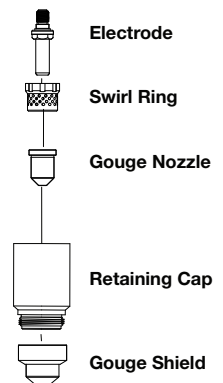

Hand Cutting Process

The air plasma cutting process uses air or nitrogen as a cutting gas and to cool the torch.

The Tomahawk® 1500 provides constant current at the set value, independent of the plasma arc length.

When preparing to operate, make sure you have all materials needed to complete the job and have taken all safety precautions. Install the machine as instructed in this manual and remember to attach the work clamp to the work piece.

- With the machine switched OFF, prepare the torch with the consumables adequate to the desired process (CUT / GRID / GOUGE).
- Connect the Torch and the work cable to the machine.
- Turn ON the Power Switch on the back of the machine; the Input Power LED on the front panel will illuminate. The unit is now ready to operate.
- Verify correct gas pressure using the Gas Purge function.
- Select the desired process using Operating Mode pushbutton.
- Set the desired cutting current using the Output Current knob.

Once the process is completed releasing the torch trigger will cause the plasma arc to turn off. The gas flow will continue, allowing the torch to cool.

- Pilot Arc
 - The air will flow for a preflow time of 2 seconds and the pilot arc will start. (Exceptions: after a thermal, the initial trigger will be ignored. This is a safety feature to prevent the pilot arc from firing unexpectedly. The other exception is if the machine is in postflow, then the preflow time is skipped and the pilot arc will start immediately.)
 - The pilot arc will run for 5.0 seconds and shut off unless the arc is brought in contact with the work and the arc is transferred. Avoid excessive pilot arc time by transferring the arc to the workpiece quickly. This will extend consumable life.
 - When the arc is brought within 1/8" - 1/4" from the work piece the arc will transfer, the current will ramp to the setting on the control panel, and the cut can last indefinitely

(or until the duty cycle of the Tomahawk® 1500 is exceeded).

- Pierce the work piece by slowly lowering the torch onto the metal at a 30° angle away from the operator. This will blow the dross away from the torch tip. Slowly rotate the torch to vertical position as the arc becomes deeper.
- Keep moving while cutting. Cut at a steady speed without pausing. Maintain the cutting speed so that the arc lag is 10° to 20° behind the travel direction.
- Use a 5° - 15° leading angle in the direction of the cut.
- Finish the cut to be made and release the trigger.
- If the dross is difficult to remove, reduce the cutting speed. High speed dross is more difficult to remove than low speed dross.
- The Post Flow time is proportional to the selected cutting current and it is divided into 4 time ranges:

Selected Cutting Current	Post Flow Time
Less than 30A	15 seconds
Between 30A and 40A	20 seconds
Between 40A and 50A	25 seconds
Greater than 50A	30 seconds

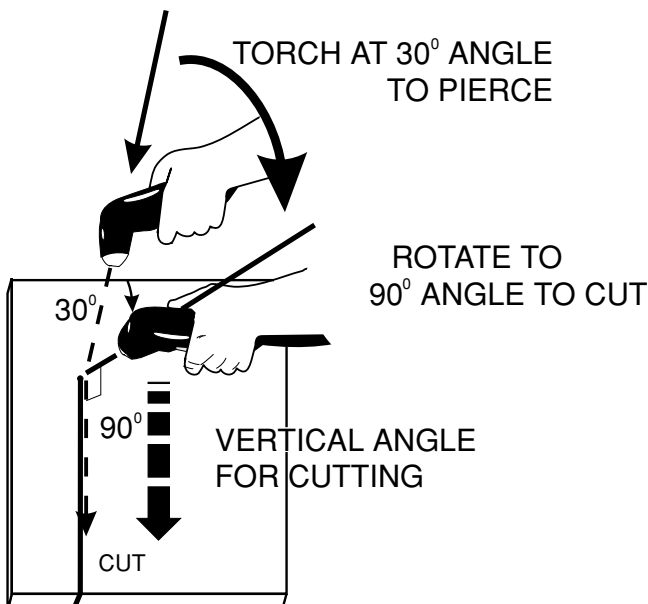

Gouging Process

Gouging is a process used to remove material without cutting entirely through the workpiece. The Tomahawk® 1500 has the capability of performing plasma gouging with the proper consumables attached to the torch. In general, gouging consumables provide a wider plasma arc compared to a cutting arc. As the material melts, it is blown forward by the pressurized gas coming out of the torch. The dross will land on the surface of the workpiece and can easily be removed after the gouging process is complete.

Applications:

Removing weld imperfections – cracks, porosity, inclusions, etc.

Back gouging for welding preparation

Removal of temporary fit up methods – tack welds, bracketing, etc.

Technique:

Hold the torch at a 45° angle to the workpiece. Pull the torch trigger to start the gouging arc. As the material is removed move the torch forward to continue removing material. When the desired amount of material has been removed, release the torch trigger to stop the gouging process.

Typically, the larger the angle between the torch and the workpiece, the deeper and slower the gouging. As the torch angle is decreased, less material is removed and the travel speeds can be increased. Keeping the torch fixed while moving forward will remove a straight line of material. Using a side-to-side, weaving motion will remove a wider area of material. The output of the Tomahawk® 1500 can also be increased or decreased to control the amount of material being removed. Most users tend to maximize the output in order to remove the most material in a short amount of time.

General Recommendations

- Follow safety precautions as printed throughout this operating manual and on the machine.
- Where possible, start the cut from the edge of the work piece. (This helps in longevity of consumable life.)
- If piercing is required, slowly lower the torch at an angle of about 30° to blow the dross away from the torch tip and slowly rotate the torch to a vertical position as the arc becomes deeper. This process will blow a lot of molten metal and dross. Be careful! Blow the dross away from the torch, the operator and any flammable objects.
- The nozzle should not be dragged on the metal surface. A drag shield is provided to maintain a consistent torch height. Refer to Torch Parts Configurations in this Section.
- Clean spatter and scale from the nozzle frequently.
- Avoid unnecessary pilot arc starts as this will reduce consumable life. The pilot arc should only be fired as a means to transfer the arc to the work piece.

WARNING

ELECTRIC SHOCK CAN KILL.

Turn off machine at the disconnect switch on the rear of the machine before tightening, cleaning or replacing consumables.



- During operation, if the “Parts in Place” Yellow LED turns on:
 - Turn OFF the machine. Allow torch to cool.
 - Check the assembly of the torch consumables. If they are not properly in place, the machine will not start. Make sure that the shield cup is hand tight. Do not use pliers or over tighten.
 - Check the conditions on the inside of the nozzle. If debris has collected, rub the inside of the nozzle to remove any oxide layer that may have built up. Refer to “Suggestions for Extra Utility from the Tomahawk® 1500 system.”
 - Check the condition of the electrode. If the end has a crater-like appearance, replace it along with the nozzle. The maximum wear depth of the electrode is approximately .060.” A green and erratic arc will indicate definite electrode failure and the electrode should be replaced immediately.
 - Replace the nozzle when the orifice exit is eroded away or oval shaped.
 - After the problem is found, or if there is nothing apparently wrong, the machine may need to be reset by turning the power switch OFF and then ON again. (It is possible for electrical noise to trip the safety circuit on rare occasions. This should not be a regular occurrence.)
- If the machine does not reset or continues to trip, consult the Troubleshooting Section.

INSPECTION OF CONSUMABLE PARTS

When the cut quality is not satisfactory, use the following guidelines for determining which consumable parts need to be changed. Inspect all parts for dirt or debris and clean as necessary.

PART	INSPECT FOR	CORRECTIVE ACTION
SHIELD CAP	CENTER HOLE OUT OF ROUND	REPLACE SHIELD CAP
	DENTS, SCRATCHES	REPLACE SHIELD CAP
RETAINING CAP	CENTER HOLE OUT OF ROUND	REPLACE RETAINING CAP
	DENTS, CRACKS	REPLACE RETAINING CAP
NOZZLE	CENTER HOLE OUT OF ROUND	REPLACE NOZZLE
	EROSION OR ARCING	REPLACE NOZZLE
SWIRL RING	DAMAGE	REPLACE SWIRL RING
	CLOGGED HOLES	BLOW OUT WITH COMPRESSED AIR. REPLACE SWIRL RING IF CLOGS CAN'T BE REMOVED
ELECTRODE	PIT DEPTH	REPLACE ELECTRODE IF CENTER PIT DEPTH IS GREATER THAN .060" (1.5 MM)
	EROSION OR ARCING	REPLACE ELECTRODE

CONSUMABLE LIFE**⚠ WARNING****ELECTRIC SHOCK CAN KILL.**

- Turn off machine at the disconnect switch on the rear of th machine before tightening, cleaning or replacing consumables.



-
1. Occasionally an oxide layer may form over the tip of the electrode, creating an insulating barrier between the electrode and nozzle. This will result in false starts. When this happens turn the power off, remove the shield cup and nozzle. Rub the inside surface of the nozzle, this will help remove any oxide buildup. Also, clean any oxide build up from the electrode. Replace the shield cup and nozzle, turn on the power and continue cutting. If false starts continue to occur after cleaning the consumables, then replace them with a new set. Do not continue to try and cut with excessively worn consumables as this can cause damage to the torch head and will degrade cut quality. Do not allow torch cable or body to contact hot surfaces.
 2. To improve consumable life, here are some suggestions that may be useful:
 - Use only Lincoln consumable parts. These parts are patented and using any other replacement consumables may cause damage to the torch or reduce cut quality.
 - Make sure the air supply to the Tomahawk® 1500 is clean and free of oil. Use several extra in line filters if necessary.
 - Minimize dross buildup on the nozzle tip by starting the cut from the edge of the plate when possible.
 - Pierce cutting should be done only when necessary. If piercing, angle torch about 30° from the plane perpendicular to the work piece, transfer the arc, then bring the torch perpendicular to the work and begin parallel movement.
 - Reduce the number of pilot arc starts without transferring to the work.
 - Reduce the pilot arc time before transferring to the work.
 - Set air pressure to recommended setting. A higher or lower pressure will cause turbulence in the plasma arc, eroding the orifice of the nozzle tip.

**MILD STEEL CUT CHARTS -
TOMAHAWK 1500, LC105 HAND TORCH**

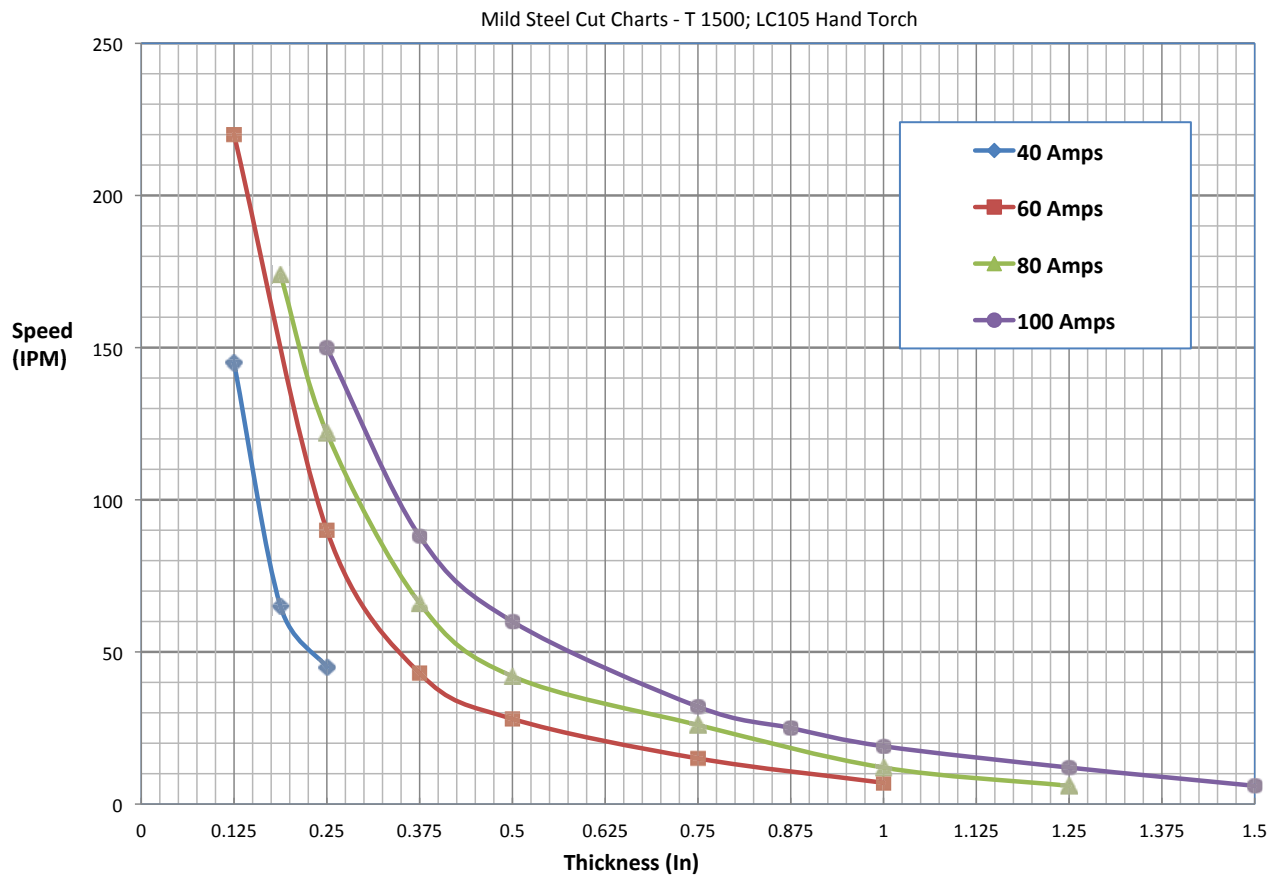

- * While air is flowing, adjust regulator to 80 psi for 25' torches and 90 psi for 50' torches.
- * Above listed speeds provide best cut quality - best cut angle, least dross, best cut surface finish.

**ALUMINUM CUT CHARTS -
TOMAHAWK 1500, LC105 HAND TORCH**

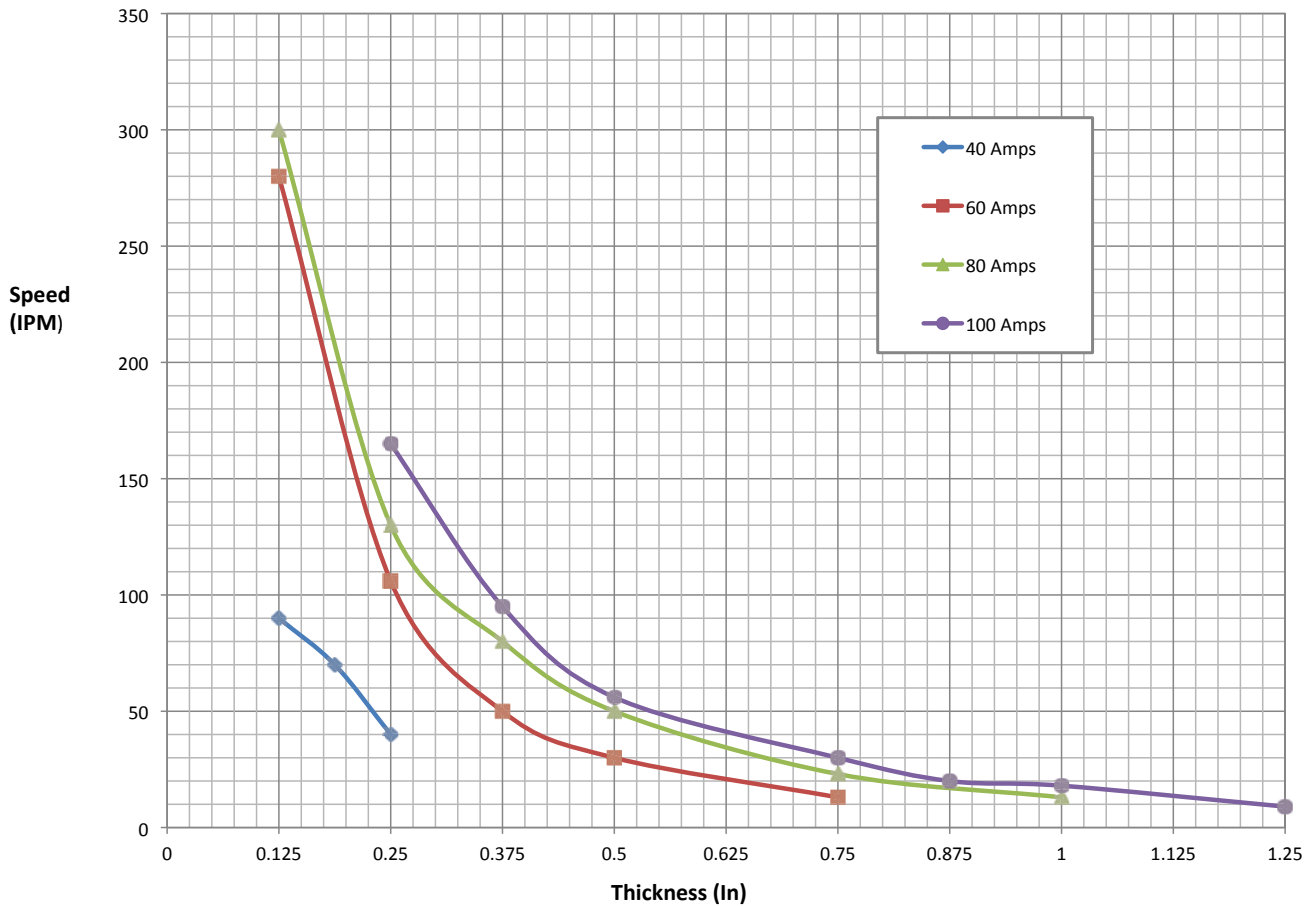

- * While air is flowing, adjust regulator to 80 psi for 25' torches and 90 psi for 50' torches.
- * Above listed speeds provide best cut quality - best cut angle, least dross, best cut surface finish.

⚠ WARNING

When using a water table and cutting aluminum under water or with water touching the underside at the aluminum plate, hydrogen gas is produced. This hydrogen gas may collect under the plate and explode during the cutting process. Make sure the water table is properly aerated to help prevent the accumulation of hydrogen gas.



**STAINLESS STEEL CUT CHARTS -
TOMAHAWK 1500, LC105 HAND TORCH**

Stainless Steel Cut Charts - LC105 Hand Torch

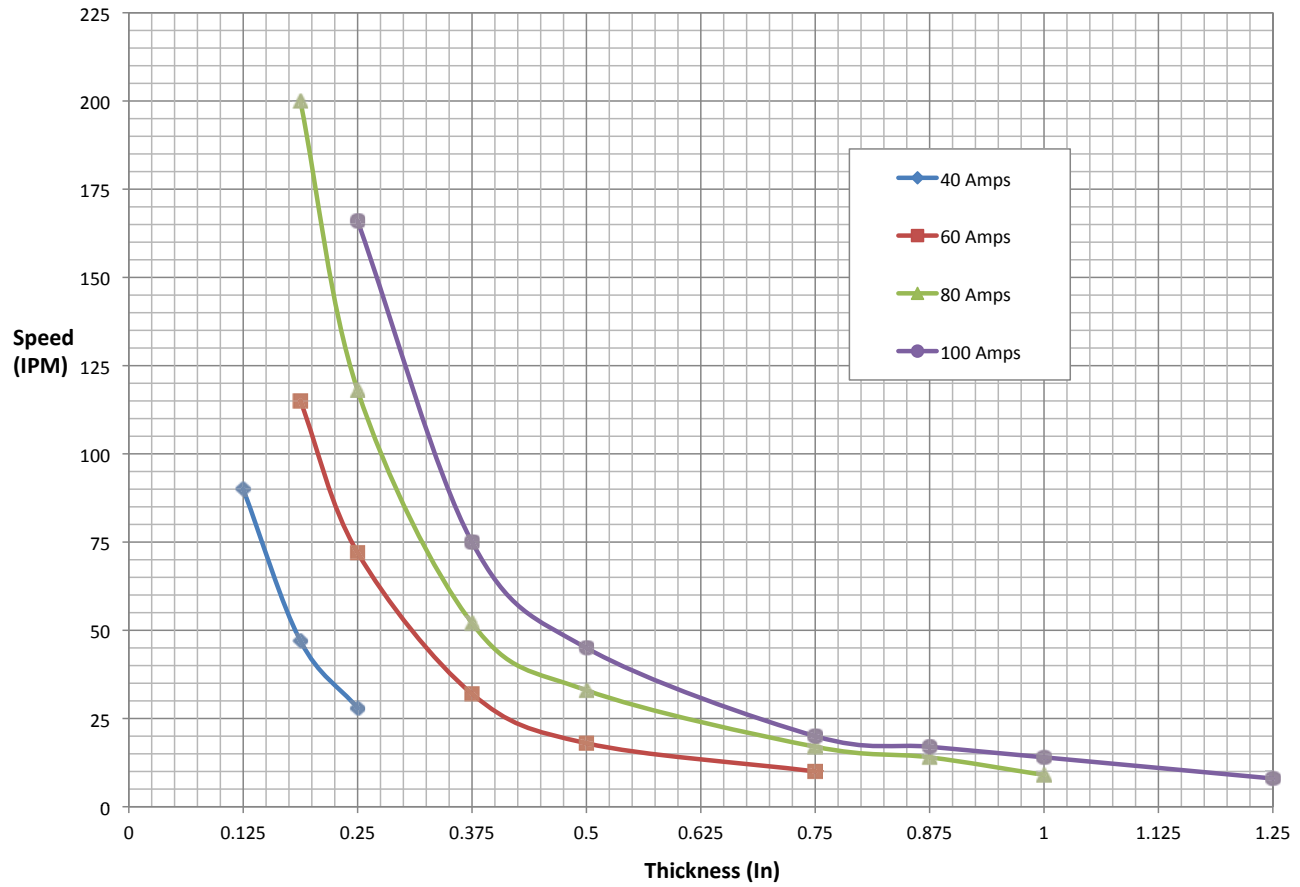

- * While air is flowing, adjust regulator to 80 psi for 25' torches and 90 psi for 50' torches.
- * Above listed speeds provide best cut quality - best cut angle, least dross, best cut surface finish.

OPTIONS/ACCESSORIES

The following options/accessories are available for your Tomahawk Plasma cutter from your local Lincoln Distributor.

K2886-1 - Plasma Circle Cutting Kit - For cutting circles from 3" to 33" in diameter (77mm to 838mm).

TORCHES

The following replacement or optional torches are available:

K2849-1 LC105 Handheld Plasma Torch 25' (7.5m)

K2849-2 LC105 Handheld Plasma Torch 50' (15m)

EXPENDABLE PARTS

TORCH COMPONENTS					
TORCH	ELECTRODE	SWIRL RING	NOZZLE	RETAINING CAP	SHIELD CAP
K2849-1	KP4141-1	KP4141-9	(40A) KP4141-4	KP4141-8	DRAG SHIELD CAP
K2849-2			(60A) KP4141-5		(40A) KP4141-14
			(80A) KP4141-6		(60-80A) KP4141-15
			(100A) KP4141-7		(100A) KP4141-16
			(80A, GOUGE) KP4141-18		GOUGE SHIELD CAP
			(100A, GOUGE) KP4141-19		(80-100A) KP4141-17

MAINTENANCE

WARNING

ELECTRIC SHOCK CAN KILL.

- Have an electrician install and service this equipment.
- Turn the input power off at the fuse box before working on equipment.
- Do not touch electrically hot parts.



DAILY PROCEDURES

POWER SUPPLY

1. Verify that the green status light is illuminated when primary power is applied to the system.
2. Rotate the output current knob to the purge position and verify that air is flowing through the torch. While air is flowing, adjust the regulator to 80 psi for 25' torches and 90 psi for 50' torches. Return the output current knob to the required output position.
3. Hold the torch 2 inches above the workpiece and pull the trigger. The pilot arc should be established in approximately 2 seconds. The arc should extend approximately 1 inch from the nozzle.

TORCH ASSEMBLY

1. Check the output cover of the torch lead for nicks or cuts. If the outer cover is damaged and the underlying wires are visible, the torch lead must be replaced. Check to make sure nothing is crushing the cable and blocking the flow of air through the torch. Also, check for and remove any kinks in the cable to maximize air flow to the torch.
2. Remove all consumables from the torch and verify that the anode-cathode insulator (brown plastic) is in good condition and has no signs of arcing.
3. Check all consumables and discard any damaged items.
4. Verify that the electrode seat is clean to ensure proper electrical contact.
5. Reassemble the torch consumables making sure that all parts are seated properly and that the retaining cap is hand tight.

MONTHLY PROCEDURES

POWER SUPPLY

1. Using clean, dry, compressed air, blow out all accumulated dust inside the machine. Be sure to clean all printed circuit boards, heatsinks, power switch, and fan. In excessively dirty environments, blow out the machine on a weekly basis. Keeping the machine clean will result in cooler operation and higher reliability.
2. Verify that all torch lead and ground connections are secure and free of corrosion.
3. Verify that the primary three phase AC connections are tight.
4. Verify that all printed circuit board connectors are installed properly.
5. Examine the sheet metal case for dents or other damage and repair as required. Keep in case in good condition to insure that high voltage parts are protected and correct spacings are maintained. All external sheet metal screws must be in place to insure case strength and electrical ground continuity,

TORCH ASSEMBLY

1. Verify that the torch lead connection at the power supply is tight and that there are no leaks. Only tighten enough to provide a gas tight seal. The connections are subject to damage if over-tightened.
2. Inspect the torch leads for nicks or cuts and replace if necessary.

Work Ground

1. Verify that work ground lead is securely fastened to the cutting table and that the connection point is free from corrosion. Use a wire brush to clean the connection point if necessary.

Gas Supply

1. Check for signs of contamination in the gas supply lines.
2. Drain filter bowl as needed.
3. Listen for gas leaks in the supply lines and the internal plumbing system. Tighten any leaking connections. Leaks can cause poor cut quality as well as torch overheating.
4. Replace the filter element as necessary. If the pressure drop across the filter is more than 10 psi, the element needs to be replaced. To replace the element:
 - Remove the bowl from the filter body
 - Remove the element and holder from body
 - Separate the element from its holder
 - Discard the used element
 - Place the new element on its holder and top with the plastic and rubber rings
 - Thread the element and holder onto the body
 - Thread the bowl onto the body

TROUBLESHOOTING

WARNING

Service and Repair should only be performed by Lincoln Electric Factory Trained Personnel. Unauthorized repairs performed on this equipment may result in danger to the technician and machine operator and will invalidate your factory warranty. For your safety and to avoid Electrical Shock, please observe all safety notes and precautions detailed throughout this manual.

This Troubleshooting Guide is provided to help you locate and repair possible machine malfunctions. Simply follow the three-step procedure listed below.

Step 1.LOCATE PROBLEM (SYMPTOM).

Look under the column labeled "PROBLEM (SYMPTOMS)". This column describes possible symptoms that the machine may exhibit. Find the listing that best describes the symptom that the machine is exhibiting.

Step 2.POSSIBLE CAUSE.

The second column labeled "POSSIBLE CAUSE" lists the obvious external possibilities that may contribute to the machine symptom.

Step 3.RECOMMENDED COURSE OF ACTION

This column provides a course of action for the Possible Cause, generally it states to contact your local Lincoln Authorized Field Service Facility.

If you do not understand or are unable to perform the Recommended Course of Action safely, contact your local Lincoln Authorized Field Service Facility.

WARNING

- Turn the input power OFF at the welding power source before installation or changing drive rolls and/or guides.
- Do not touch electrically live parts.
- Welding power source must be connected to system ground per the National Electrical Code or any applicable local codes.
- Only qualified personnel should perform maintenance work.



Observe all additional Safety Guidelines detailed throughout this manual.



If for any reason you do not understand the procedures or are unable to perform the maintenance or repairs safely, contact your Lincoln Authorized Service Facility for technical troubleshooting assistance before you proceed.

WWW.LINCOLNELECTRIC.COM/LOCATOR

Observe all Safety Guidelines detailed throughout this manual

PROBLEMS (SYMPTOMS)	POSSIBLE AREAS OF MISADJUSTMENTS	RECOMMENDED COURSE OF ACTION
Input circuit breaker trips repeatedly.	<ol style="list-style-type: none"> 1. Verify that the input circuit protection is properly sized per the voltage being supplied. See Technical Specification page. 2. Install a larger input circuit or turn the output control to a lower amperage. 3. Check the input power to be sure it is on. 	<p>If all recommended possible areas of misadjustment have been checked and the problem persists, Contact your local Lincoln Authorized Field Service Facility.</p>
No Status indicators light and the fan does not operate 5 seconds after the power switch is turned on.	<ol style="list-style-type: none"> 1. Check the power line fuses or breakers and machine connection. 2. Disconnect input power at fuse/breaker panel and check line switch continuity. Replace line switch if bad. 3. Possible faulty Control Board. 	
No Status indicators light 5 seconds after the power switch is turned on, but the fan operates.	<ol style="list-style-type: none"> 1. Possible faulty Control board. 	
The Thermal LED does not go out.	<ol style="list-style-type: none"> 1. Check that rear brickwork is not blocked. Check that fan rotates freely. Check that heatsink fins are not clogged with dirt. 	



If for any reason you do not understand the procedures or are unable to perform the maintenance or repairs safely, contact your Lincoln Authorized Service Facility for technical troubleshooting assistance before you proceed.

WWW.LINCOLNELECTRIC.COM/LOCATOR

Observe all Safety Guidelines detailed throughout this manual

<p>PROBLEMS (SYMPTOMS)</p>	<p>POSSIBLE AREAS OF MISADJUSTMENTS</p>	<p>RECOMMENDED COURSE OF ACTION</p>
<p>The Tomahawk® 1500 powers up properly but there is no response when the trigger is pulled and only the POWER LED is lit.</p>	<ol style="list-style-type: none"> 1. Turn the output knob to purge zone on the front of the Tomahawk® 1500 . If air does not flow, then: <ul style="list-style-type: none"> • The main gas solenoid assembly/pressure sensor may be faulty. Check or replace. • Possible faulty Control board. 2. Remove the handles (or barrel) of the torch and examine all the connections. 3. Check for proper trigger switch operation. Replace the trigger switch or torch cable if defective. 4. Possible faulty Control board. 	<p>If all recommended possible areas of mis-adjustment have been checked and the problem persists, Contact your local Lincoln Authorized Field Service Facility.</p>



If for any reason you do not understand the procedures or are unable to perform the maintenance or repairs safely, contact your Lincoln Authorized Service Facility for technical troubleshooting assistance before you proceed.

WWW.LINCOLNELECTRIC.COM/LOCATOR

Observe all Safety Guidelines detailed throughout this manual

PROBLEMS (SYMPTOMS)	POSSIBLE AREAS OF MISADJUSTMENTS	RECOMMENDED COURSE OF ACTION
<p>When the trigger is pulled air begins to flow, but there is no pilot arc after at least 3 seconds.</p>	<ol style="list-style-type: none"> 1. Check the torch consumables to be sure they are not dirty or greasy, and are in good shape. Replace the consumables if necessary. 2. Make sure the air pressure is set correctly. 3. Make sure there are no kinks or restrictions for air flow in the torch cable. Replace cable as needed. 4. If a slight thump cannot be felt in the torch when the trigger is pulled, check for loose connection in the torch head. 5. Possible faulty Control board. 	<p>If all recommended possible areas of misadjustment have been checked and the problem persists, Contact your local Lincoln Authorized Field Service Facility.</p>
<p>The air begins to flow and there is a very brief arc that snaps out consistently with repeated trigger pulls.</p>	<ol style="list-style-type: none"> 1. Check the torch consumables to be sure they are in tight, not dirty or greasy and in good shape. Replace if necessary. 2. Make sure the air pressure is set correctly. 3. Possible faulty in Control board. 	
<p>The arc starts but sputters badly.</p>	<ol style="list-style-type: none"> 1. Check the torch consumables to be sure they are in tight, not dirty or greasy and in good shape. Replace if necessary. 2. Check air supply for oil or a great deal of water. If there is oil or a great deal of water, the air must be filtered or the machine switched to nitrogen or bottled air. 3. Make sure the air pressure is set correctly. 	



If for any reason you do not understand the procedures or are unable to perform the maintenance or repairs safely, contact your Lincoln Authorized Service Facility for technical troubleshooting assistance before you proceed.

WWW.LINCOLNELECTRIC.COM/LOCATOR

Observe all Safety Guidelines detailed throughout this manual

PROBLEMS (SYMPTOMS)	POSSIBLE AREAS OF MISADJUSTMENTS	RECOMMENDED COURSE OF ACTION
<p>Pilot arc starts but will not transfer when brought near work.</p>	<ol style="list-style-type: none"> 1. Check work lead connection for clean, secure connection. 2. Plasma will only cut conductive material. Do not attempt to cut fiberglass, plastic, rubber, PVC or any other non-conductive material. 3. Make sure work piece is clean and dry. Remove any scale, rust or dross. 4. Check all connections to Control board. 5. Possible faulty Control board. 	<p>If all recommended possible areas of misadjustment have been checked and the problem persists, Contact your local Lincoln Authorized Field Service Facility.</p>



If for any reason you do not understand the procedures or are unable to perform the maintenance or repairs safely, contact your Lincoln Authorized Service Facility for technical troubleshooting assistance before you proceed.

WWW.LINCOLNELECTRIC.COM/LOCATOR



Observe all Safety Guidelines detailed throughout this manual

STATUS BOARD INDICATORS

SYMPTOM	CHECK
Yellow Gas Pressure LED is lit and steady.	<ol style="list-style-type: none"> 1. Make sure there is at least 80 psi connected to the gas connection at the back of the machine. 2. Turn the output knob to the purge zone and set the regulator to the correct pressure. The pressure may increase when air stops flowing but this is normal. Do not reset the pressure while the air is OFF. 3. Possible faulty Pressure Switch. 4. Possible faulty Control board.
The Yellow Parts In Place LED is lit and steady.	<ol style="list-style-type: none"> 1. Verify Torch consumables are in good condition and properly installed. If torch and consumables are properly installed, the Yellow LED should turn off. The unit may be required to have the input power turned off then back on. Normal cutting or gouging can resume.
The Thermal LED is lit.	<ol style="list-style-type: none"> 1. The machine's thermostat has tripped due to exceeded duty cycle limits. Do NOT turn the power off. Allow the machine to cool for 15 - 30 minutes and the thermostat will reset itself. 2. The machine's air louvers or fans are obstructed such that air cannot flow to properly cool the machine. Remove any foreign material that may block air flow. Blow the machine out with a clean, dry air stream. 3. Possible faulty Control board.

Error condition list.

At first, try turning the machine OFF, wait for a few seconds, then turn the machine ON again. If the error remains, troubleshooting is required. Please contact the nearest technical service center or Lincoln Electric and report the LED Status found on the machine Front Panel.

	 On (Green LED)	 Blink (Red LED)	 Blink (Yellow)
No pilot arc transfer	<ol style="list-style-type: none"> 1. This occurs if after 4 seconds the Pilot Arc isn't transferred to the workpiece. The machine stops the pilot arc to avoid overheating the Torch. 2. To restore the machine: <ul style="list-style-type: none"> • Release the Torch Trigger. The blinking LEDs will change to steady ON. • Pull the Torch Trigger and verify correct operation. 		







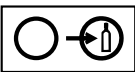

If for any reason you do not understand the procedures or are unable to perform the maintenance or repairs safely, contact your Lincoln Authorized Service Facility for technical troubleshooting assistance before you proceed.

WWW.LINCOLNELECTRIC.COM/LOCATOR

Observe all Safety Guidelines detailed throughout this manual

Error condition list

<p>No pilot arc established</p>	 On (Green LED)	 On (Yellow LED)	 On (Yellow LED)	
	<p>1. The machine output is triggered. During this period the machine will attempt to start the pilot arc 4 times. If the pilot arc does not start, the machine automatically will enter into a safe status condition that will allow troubleshooting as necessary.</p> <p>2. To restore the machine:</p> <ul style="list-style-type: none"> • Turn OFF the Power switch. • Check the correct placement of the Torch consumables and parts. • Check the Torch electrical connections. • Turn ON the machine. 			
<p>Trigger Locked</p>	 On (Green LED)	 On (Yellow LED)	 On (Yellow LED)	 On (Yellow LED)
	<p>1. This occurs if the machine is turned ON (or if it is restarted after Thermal reset) with the Torch Trigger pulled. This condition avoids unsafe operating conditions. The machine is disabled such that manual cutting or gouging processes can ONLY be initiated under the direct control of the operator.</p> <p>2. To restore the machine:</p> <ul style="list-style-type: none"> • Release the Torch Trigger. • The LED's will return to normal status and cutting or Gouging may resume. <p>3. If this error condition persists, check for a malfunctioning torch or remote connection trigger.</p>			



If for any reason you do not understand the procedures or are unable to perform the maintenance or repairs safely, contact your Lincoln Authorized Service Facility for technical troubleshooting assistance before you proceed.

WWW.LINCOLNELECTRIC.COM/LOCATOR

WARNING



HIGH VOLTAGE
can kill

- Do not operate with covers removed.
- Disconnect input power by unplugging power cord before servicing.
- Do not touch electrically live parts
- Only qualified persons should install, use or service this machine.

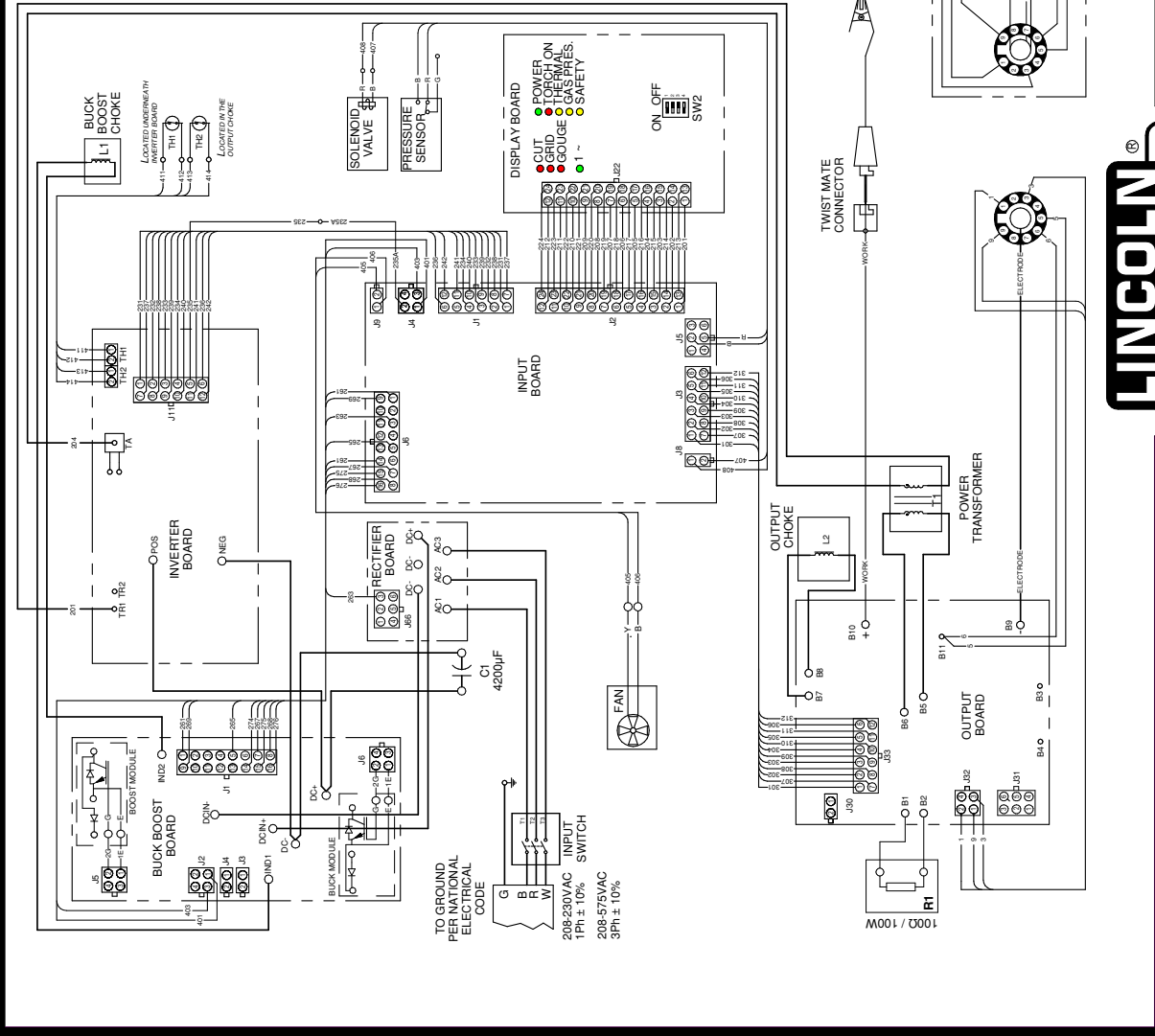

CLEVELAND, OHIO U.S.A.



NOTE: This diagram is for reference only. It may not be accurate for all machines covered by this manual. The specific diagram for a particular code is posted inside the machine on one of the enclosure panels. If the diagram is illegible, write to the Service Department for a replacement. Give the equipment code number.

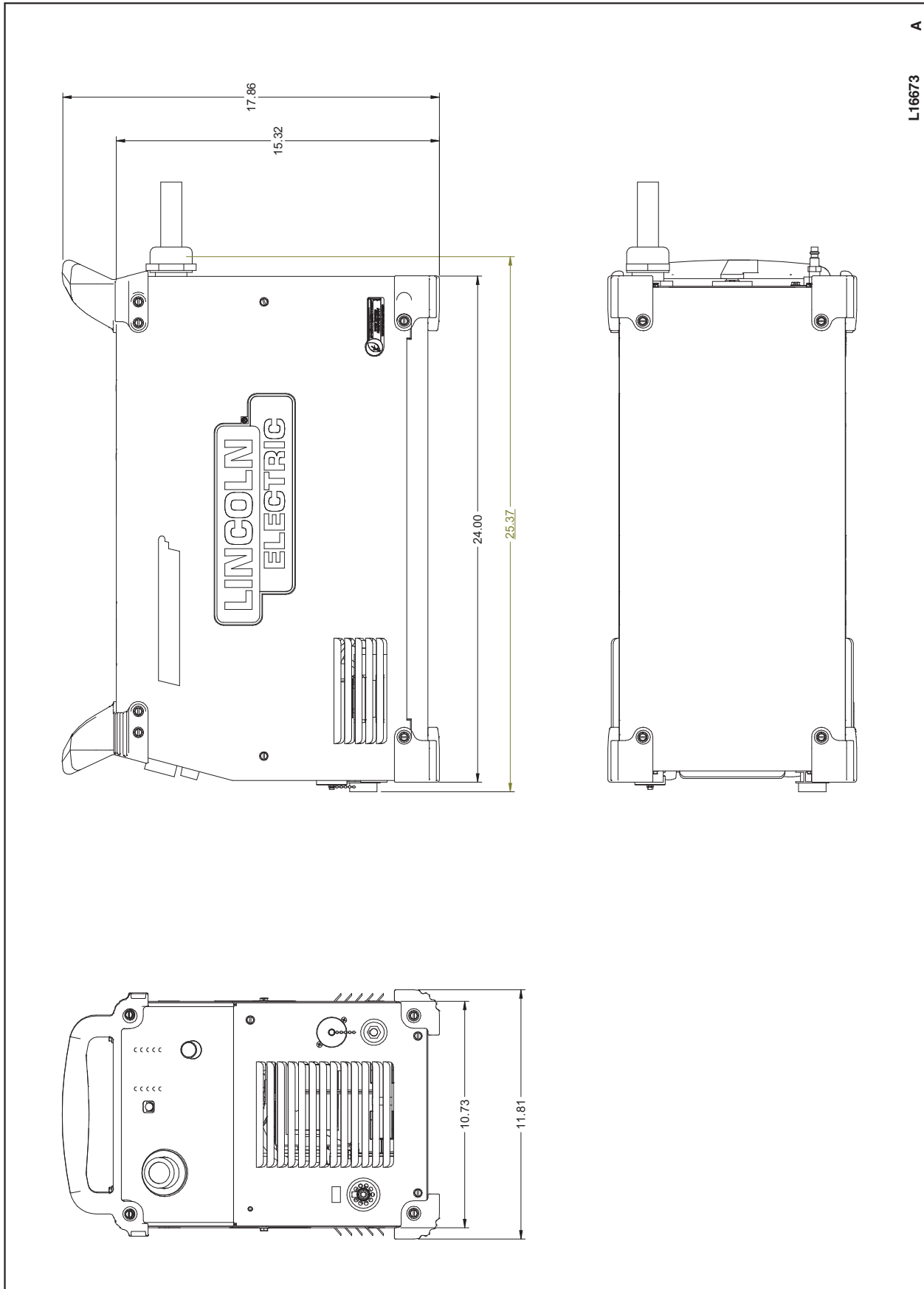

L16673 A

891-N3

			
WARNING	<ul style="list-style-type: none"> Do not touch electrically live parts or electrode with skin or wet clothing. Insulate yourself from work and ground. 	<ul style="list-style-type: none"> Keep flammable materials away. 	<ul style="list-style-type: none"> Wear eye, ear and body protection.
Spanish AVISO DE PRECAUCION	<ul style="list-style-type: none"> No toque las partes o los electrodos bajo carga con la piel o ropa mojada. Aíslese del trabajo y de la tierra. 	<ul style="list-style-type: none"> Mantenga el material combustible fuera del área de trabajo. 	<ul style="list-style-type: none"> Protéjase los ojos, los oídos y el cuerpo.
French ATTENTION	<ul style="list-style-type: none"> Ne laissez ni la peau ni des vêtements mouillés entrer en contact avec des pièces sous tension. Isolez-vous du travail et de la terre. 	<ul style="list-style-type: none"> Gardez à l'écart de tout matériel inflammable. 	<ul style="list-style-type: none"> Protégez vos yeux, vos oreilles et votre corps.
German WARNUNG	<ul style="list-style-type: none"> Berühren Sie keine stromführenden Teile oder Elektroden mit Ihrem Körper oder feuchter Kleidung! Isolieren Sie sich von den Elektroden und dem Erdboden! 	<ul style="list-style-type: none"> Entfernen Sie brennbares Material! 	<ul style="list-style-type: none"> Tragen Sie Augen-, Ohren- und Körperschutz!
Portuguese ATENÇÃO	<ul style="list-style-type: none"> Não toque partes elétricas e electrodos com a pele ou roupa molhada. Isole-se da peça e terra. 	<ul style="list-style-type: none"> Mantenha inflamáveis bem guardados. 	<ul style="list-style-type: none"> Use proteção para a vista, ouvido e corpo.
Japanese 注意事項	<ul style="list-style-type: none"> 通電中の電気部品、又は溶材にヒフやぬれた布で触れないこと。 施工物やアースから身体が絶縁されている様にして下さい。 	<ul style="list-style-type: none"> 燃えやすいものの側での溶接作業は絶対にしてはなりません。 	<ul style="list-style-type: none"> 目、耳及び身体に保護具をして下さい。
Chinese 警告	<ul style="list-style-type: none"> 皮肤或湿衣物切勿接触带电部件及焊条。 使你自已与地面和工件绝缘。 	<ul style="list-style-type: none"> 把一切易燃物品移离工作场所。 	<ul style="list-style-type: none"> 佩戴眼、耳及身体劳动保护用具。
Korean 위험	<ul style="list-style-type: none"> 전도체나 용접봉을 젖은 형갑 또는 피부로 절대 접촉치 마십시오. 모재와 접지를 접촉치 마십시오. 	<ul style="list-style-type: none"> 인화성 물질을 접근시키지 마십시오. 	<ul style="list-style-type: none"> 눈, 귀와 몸에 보호장구를 착용하십시오.
Arabic تحذير	<ul style="list-style-type: none"> لا تلمس الاجزاء التي يسري فيها التيار الكهربائي أو الألكترود بجسدك أو بالملابس المبللة بالماء. ضع عازلا على جسمك خلال العمل. 	<ul style="list-style-type: none"> ضع المواد القابلة للاشتعال في مكان بعيد. 	<ul style="list-style-type: none"> ضع أدوات وملابس واقية على عينيك وأذنيك وجسمك.

READ AND UNDERSTAND THE MANUFACTURER'S INSTRUCTION FOR THIS EQUIPMENT AND THE CONSUMABLES TO BE USED AND FOLLOW YOUR EMPLOYER'S SAFETY PRACTICES.

SE RECOMIENDA LEER Y ENTENDER LAS INSTRUCCIONES DEL FABRICANTE PARA EL USO DE ESTE EQUIPO Y LOS CONSUMIBLES QUE VA A UTILIZAR, SIGA LAS MEDIDAS DE SEGURIDAD DE SU SUPERVISOR.

LISEZ ET COMPRENEZ LES INSTRUCTIONS DU FABRICANT EN CE QUI REGARDE CET EQUIPMENT ET LES PRODUITS A ETRE EMPLOYES ET SUIVEZ LES PROCEDURES DE SECURITE DE VOTRE EMPLOYEUR.

LESEN SIE UND BEFOLGEN SIE DIE BETRIEBSANLEITUNG DER ANLAGE UND DEN ELEKTRODENEINSATZ DES HERSTELLERS. DIE UNFALLVERHÜTUNGSVORSCHRIFTEN DES ARBEITGEBERS SIND EBENFALLS ZU BEACHTEN.

			
<ul style="list-style-type: none"> ● Keep your head out of fumes. ● Use ventilation or exhaust to remove fumes from breathing zone. 	<ul style="list-style-type: none"> ● Turn power off before servicing. 	<ul style="list-style-type: none"> ● Do not operate with panel open or guards off. 	WARNING
<ul style="list-style-type: none"> ● Los humos fuera de la zona de respiración. ● Mantenga la cabeza fuera de los humos. Utilice ventilación o aspiración para gases. 	<ul style="list-style-type: none"> ● Desconectar el cable de alimentación de poder de la máquina antes de iniciar cualquier servicio. 	<ul style="list-style-type: none"> ● No operar con panel abierto o guardas quitadas. 	Spanish AVISO DE PRECAUCION
<ul style="list-style-type: none"> ● Gardez la tête à l'écart des fumées. ● Utilisez un ventilateur ou un aspirateur pour ôter les fumées des zones de travail. 	<ul style="list-style-type: none"> ● Débranchez le courant avant l'entretien. 	<ul style="list-style-type: none"> ● N'opérez pas avec les panneaux ouverts ou avec les dispositifs de protection enlevés. 	French ATTENTION
<ul style="list-style-type: none"> ● Vermeiden Sie das Einatmen von Schweißrauch! ● Sorgen Sie für gute Be- und Entlüftung des Arbeitsplatzes! 	<ul style="list-style-type: none"> ● Strom vor Wartungsarbeiten abschalten! (Netzstrom völlig öffnen; Maschine anhalten!) 	<ul style="list-style-type: none"> ● Anlage nie ohne Schutzgehäuse oder Innenschutzverkleidung in Betrieb setzen! 	German WARNUNG
<ul style="list-style-type: none"> ● Mantenha seu rosto da fumaça. ● Use ventilação e exaustão para remover fumo da zona respiratória. 	<ul style="list-style-type: none"> ● Não opere com as tampas removidas. ● Desligue a corrente antes de fazer serviço. ● Não toque as partes elétricas nuas. 	<ul style="list-style-type: none"> ● Mantenha-se afastado das partes moventes. ● Não opere com os painéis abertos ou guardas removidas. 	Portuguese ATENÇÃO
<ul style="list-style-type: none"> ● ヒュームから頭を離すようにして下さい。 ● 換気や排煙に十分留意して下さい。 	<ul style="list-style-type: none"> ● メンテナンス・サービスに取りかかる際には、まず電源スイッチを必ず切して下さい。 	<ul style="list-style-type: none"> ● パネルやカバーを取り外したまま機械操作をしないで下さい。 	Japanese 注意事項
<ul style="list-style-type: none"> ● 頭部遠離煙霧。 ● 在呼吸區使用通風或排風器除煙。 	<ul style="list-style-type: none"> ● 維修前切斷電源。 	<ul style="list-style-type: none"> ● 儀表板打開或沒有安全罩時不準作業。 	Chinese 警告
<ul style="list-style-type: none"> ● 얼굴로부터 용접가스를 멀리하십시오. ● 호흡지역으로부터 용접가스를 제거하기 위해 가스제거기나 통풍기를 사용하십시오. 	<ul style="list-style-type: none"> ● 보수전에 전원을 차단하십시오. 	<ul style="list-style-type: none"> ● 판넬이 열린 상태로 작동치 마십시오. 	Korean 위험
<ul style="list-style-type: none"> ● ابعد رأسك بعيداً عن الدخان. ● استعمل التهوية أو جهاز ضغط الدخان للخارج لكي تبعد الدخان عن المنطقة التي تتنفس فيها. 	<ul style="list-style-type: none"> ● اقطع التيار الكهربائي قبل القيام بأية صيانة. 	<ul style="list-style-type: none"> ● لا تشغيل هذا الجهاز اذا كانت الاغطية الحديدية الواقية ليست عليه. 	Arabic تحذير

LEIA E COMPREENDA AS INSTRUÇÕES DO FABRICANTE PARA ESTE EQUIPAMENTO E AS PARTES DE USO, E SIGA AS PRÁTICAS DE SEGURANÇA DO EMPREGADOR.

使う機械や溶材のメーカーの指示書をよく読み、まず理解して下さい。そして貴社の安全規定に従って下さい。

請詳細閱讀並理解製造廠提供的說明以及應該使用的銀焊材料，並請遵守貴方的有關勞動保護規定。

이 제품에 동봉된 작업지침서를 숙지하시고 귀사의 작업자 안전수칙을 준수하시기 바랍니다.

اقرأ بتمعن وافهم تعليمات المصنع المنتج لهذه المعدات والمواد قبل استعمالها واتبع تعليمات الوقاية لصاحب العمل.

CUSTOMER ASSISTANCE POLICY

The business of The Lincoln Electric Company is manufacturing and selling high quality welding equipment, consumables, and cutting equipment. Our challenge is to meet the needs of our customers and to exceed their expectations. On occasion, purchasers may ask Lincoln Electric for advice or information about their use of our products. We respond to our customers based on the best information in our possession at that time. Lincoln Electric is not in a position to warrant or guarantee such advice, and assumes no liability, with respect to such information or advice. We expressly disclaim any warranty of any kind, including any warranty of fitness for any customer's particular purpose, with respect to such information or advice. As a matter of practical consideration, we also cannot assume any responsibility for updating or correcting any such information or advice once it has been given, nor does the provision of information or advice create, expand or alter any warranty with respect to the sale of our products.

Lincoln Electric is a responsive manufacturer, but the selection and use of specific products sold by Lincoln Electric is solely within the control of, and remains the sole responsibility of the customer. Many variables beyond the control of Lincoln Electric affect the results obtained in applying these types of fabrication methods and service requirements.

Subject to Change – This information is accurate to the best of our knowledge at the time of printing. Please refer to www.lincolnelectric.com for any updated information.



THE LINCOLN ELECTRIC COMPANY

22801 St. Clair Avenue • Cleveland, OH • 44117-1199 • U.S.A.
Phone: +1.216.481.8100 • www.lincolnelectric.com