



NOTE: This manual will cover most of the troubleshooting and repair procedures for the code numbers listed. Some variances may exist when troubleshooting/repairing later code numbers.

POWER FEED 10M SINGLE/DUAL

For use with machines having Code Numbers:

10962, 11194, 11897, 11898, 11086, 11193, 11216, 11439, 11771, 11772, 11895, 11896, 11901

SERVICE MANUAL

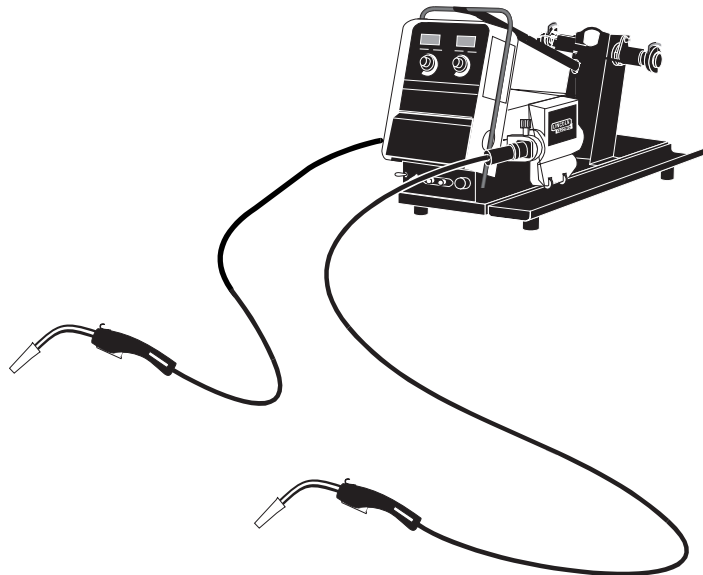

⚠ WARNING

⚠ CALIFORNIA PROPOSITION 65 WARNINGS ⚠

Diesel engine exhaust and some of its constituents are known to the State of California to cause cancer, birth defects, and other reproductive harm.

The Above For Diesel Engines

The engine exhaust from this product contains chemicals known to the State of California to cause cancer, birth defects, or other reproductive harm.

The Above For Gasoline Engines

ARC WELDING CAN BE HAZARDOUS. PROTECT YOURSELF AND OTHERS FROM POSSIBLE SERIOUS INJURY OR DEATH. KEEP CHILDREN AWAY. PACEMAKER WEARERS SHOULD CONSULT WITH THEIR DOCTOR BEFORE OPERATING.

Read and understand the following safety highlights. For additional safety information, it is strongly recommended that you purchase a copy of "Safety in Welding & Cutting - ANSI Standard Z49.1" from the American Welding Society, P.O. Box 351040, Miami, Florida 33135 or CSA Standard W117.2-1974. A Free copy of "Arc Welding Safety" booklet E205 is available from the Lincoln Electric Company, 22801 St. Clair Avenue, Cleveland, Ohio 44117-1199.

BE SURE THAT ALL INSTALLATION, OPERATION, MAINTENANCE AND REPAIR PROCEDURES ARE PERFORMED ONLY BY QUALIFIED INDIVIDUALS.



FOR ENGINE powered equipment.

1.a. Turn the engine off before troubleshooting and maintenance work unless the maintenance work requires it to be running.



1.b. Operate engines in open, well-ventilated areas or vent the engine exhaust fumes outdoors.



1.c. Do not add the fuel near an open flame welding arc or when the engine is running. Stop the engine and allow it to cool before refueling to prevent spilled fuel from vaporizing on contact with hot engine parts and igniting. Do not spill fuel when filling tank. If fuel is spilled, wipe it up and do not start engine until fumes have been eliminated.

1.d. Keep all equipment safety guards, covers and devices in position and in good repair. Keep hands, hair, clothing and tools away from V-belts, gears, fans and all other moving parts when starting, operating or repairing equipment.

1.e. In some cases it may be necessary to remove safety guards to perform required maintenance. Remove guards only when necessary and replace them when the maintenance requiring their removal is complete. Always use the greatest care when working near moving parts.



1.f. Do not put your hands near the engine fan. Do not attempt to override the governor or idler by pushing on the throttle control rods while the engine is running.

1.g. To prevent accidentally starting gasoline engines while turning the engine or welding generator during maintenance work, disconnect the spark plug wires, distributor cap or magneto wire as appropriate.

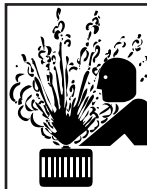

1.h. To avoid scalding, do not remove the radiator pressure cap when the engine is hot.



ELECTRIC AND MAGNETIC FIELDS may be dangerous

2.a. Electric current flowing through any conductor causes localized Electric and Magnetic Fields (EMF). Welding current creates EMF fields around welding cables and welding machines

2.b. EMF fields may interfere with some pacemakers, and welders having a pacemaker should consult their physician before welding.

2.c. Exposure to EMF fields in welding may have other health effects which are now not known.

2.d. All welders should use the following procedures in order to minimize exposure to EMF fields from the welding circuit:

2.d.1. Route the electrode and work cables together - Secure them with tape when possible.

2.d.2. Never coil the electrode lead around your body.

2.d.3. Do not place your body between the electrode and work cables. If the electrode cable is on your right side, the work cable should also be on your right side.

2.d.4. Connect the work cable to the workpiece as close as possible to the area being welded.

2.d.5. Do not work next to welding power source.

Mar '95



ELECTRIC SHOCK can kill.

- 3.a. The electrode and work (or ground) circuits are electrically “hot” when the welder is on. Do not touch these “hot” parts with your bare skin or wet clothing. Wear dry, hole-free gloves to insulate hands.
- 3.b. Insulate yourself from work and ground using dry insulation. Make certain the insulation is large enough to cover your full area of physical contact with work and ground.
- In addition to the normal safety precautions, if welding must be performed under electrically hazardous conditions (in damp locations or while wearing wet clothing; on metal structures such as floors, gratings or scaffolds; when in cramped positions such as sitting, kneeling or lying, if there is a high risk of unavoidable or accidental contact with the workpiece or ground) use the following equipment:**
- Semiautomatic DC Constant Voltage (Wire) Welder.
 - DC Manual (Stick) Welder.
 - AC Welder with Reduced Voltage Control.
- 3.c. In semiautomatic or automatic wire welding, the electrode, electrode reel, welding head, nozzle or semiautomatic welding gun are also electrically “hot”.
- 3.d. Always be sure the work cable makes a good electrical connection with the metal being welded. The connection should be as close as possible to the area being welded.
- 3.e. Ground the work or metal to be welded to a good electrical (earth) ground.
- 3.f. Maintain the electrode holder, work clamp, welding cable and welding machine in good, safe operating condition. Replace damaged insulation.
- 3.g. Never dip the electrode in water for cooling.
- 3.h. Never simultaneously touch electrically “hot” parts of electrode holders connected to two welders because voltage between the two can be the total of the open circuit voltage of both welders.
- 3.i. When working above floor level, use a safety belt to protect yourself from a fall should you get a shock.
- 3.j. Also see Items 6.c. and 8.



ARC RAYS can burn.

- 4.a. Use a shield with the proper filter and cover plates to protect your eyes from sparks and the rays of the arc when welding or observing open arc welding. Headshield and filter lens should conform to ANSI Z87.1 standards.
- 4.b. Use suitable clothing made from durable flame-resistant material to protect your skin and that of your helpers from the arc rays.
- 4.c. Protect other nearby personnel with suitable, non-flammable screening and/or warn them not to watch the arc nor expose themselves to the arc rays or to hot spatter or metal.



FUMES AND GASES can be dangerous.

- 5.a. Welding may produce fumes and gases hazardous to health. Avoid breathing these fumes and gases. When welding, keep your head out of the fume. Use enough ventilation and/or exhaust at the arc to keep fumes and gases away from the breathing zone. **When welding with electrodes which require special ventilation such as stainless or hard facing (see instructions on container or MSDS) or on lead or cadmium plated steel and other metals or coatings which produce highly toxic fumes, keep exposure as low as possible and below Threshold Limit Values (TLV) using local exhaust or mechanical ventilation. In confined spaces or in some circumstances, outdoors, a respirator may be required. Additional precautions are also required when welding on galvanized steel.**
5. b. The operation of welding fume control equipment is affected by various factors including proper use and positioning of the equipment, maintenance of the equipment and the specific welding procedure and application involved. Worker exposure level should be checked upon installation and periodically thereafter to be certain it is within applicable OSHA PEL and ACGIH TLV limits.
- 5.c. Do not weld in locations near chlorinated hydrocarbon vapors coming from degreasing, cleaning or spraying operations. The heat and rays of the arc can react with solvent vapors to form phosgene, a highly toxic gas, and other irritating products.
- 5.d. Shielding gases used for arc welding can displace air and cause injury or death. Always use enough ventilation, especially in confined areas, to insure breathing air is safe.
- 5.e. Read and understand the manufacturer's instructions for this equipment and the consumables to be used, including the material safety data sheet (MSDS) and follow your employer's safety practices. MSDS forms are available from your welding distributor or from the manufacturer.
- 5.f. Also see item 1.b.

AUG '06

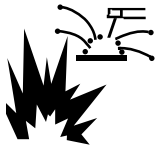

WELDING SPARKS can cause fire or explosion.

6.a. Remove fire hazards from the welding area.

If this is not possible, cover them to prevent the welding sparks from starting a fire.

Remember that welding sparks and hot

materials from welding can easily go through small cracks and openings to adjacent areas. Avoid welding near hydraulic lines. Have a fire extinguisher readily available.

6.b. Where compressed gases are to be used at the job site, special precautions should be used to prevent hazardous situations. Refer to "Safety in Welding and Cutting" (ANSI Standard Z49.1) and the operating information for the equipment being used.

6.c. When not welding, make certain no part of the electrode circuit is touching the work or ground. Accidental contact can cause overheating and create a fire hazard.

6.d. Do not heat, cut or weld tanks, drums or containers until the proper steps have been taken to insure that such procedures will not cause flammable or toxic vapors from substances inside. They can cause an explosion even though they have been "cleaned". For information, purchase "Recommended Safe Practices for the Preparation for Welding and Cutting of Containers and Piping That Have Held Hazardous Substances", AWS F4.1 from the American Welding Society (see address above).

6.e. Vent hollow castings or containers before heating, cutting or welding. They may explode.

6.f. Sparks and spatter are thrown from the welding arc. Wear oil free protective garments such as leather gloves, heavy shirt, cuffless trousers, high shoes and a cap over your hair. Wear ear plugs when welding out of position or in confined places. Always wear safety glasses with side shields when in a welding area.

6.g. Connect the work cable to the work as close to the welding area as practical. Work cables connected to the building framework or other locations away from the welding area increase the possibility of the welding current passing through lifting chains, crane cables or other alternate circuits. This can create fire hazards or overheat lifting chains or cables until they fail.

6.h. Also see item 1.c.

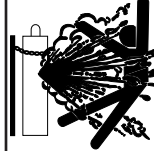

CYLINDER may explode if damaged.

7.a. Use only compressed gas cylinders containing the correct shielding gas for the process used and properly operating regulators designed for the gas and pressure used. All hoses, fittings, etc. should be suitable for the application and maintained in good condition.

7.b. Always keep cylinders in an upright position securely chained to an undercarriage or fixed support.

7.c. Cylinders should be located:

- Away from areas where they may be struck or subjected to physical damage.

- A safe distance from arc welding or cutting operations and any other source of heat, sparks, or flame.

7.d. Never allow the electrode, electrode holder or any other electrically "hot" parts to touch a cylinder.

7.e. Keep your head and face away from the cylinder valve outlet when opening the cylinder valve.

7.f. Valve protection caps should always be in place and hand tight except when the cylinder is in use or connected for use.

7.g. Read and follow the instructions on compressed gas cylinders, associated equipment, and CGA publication P-1, "Precautions for Safe Handling of Compressed Gases in Cylinders," available from the Compressed Gas Association 1235 Jefferson Davis Highway, Arlington, VA 22202.



FOR ELECTRICALLY powered equipment.

8.a. Turn off input power using the disconnect switch at the fuse box before working on the equipment.

8.b. Install equipment in accordance with the U.S. National Electrical Code, all local codes and the manufacturer's recommendations.

8.c. Ground the equipment in accordance with the U.S. National Electrical Code and the manufacturer's recommendations.

Mar '95

PRÉCAUTIONS DE SÛRETÉ

Pour votre propre protection lire et observer toutes les instructions et les précautions de sûreté spécifiques qui paraissent dans ce manuel aussi bien que les précautions de sûreté générales suivantes:

Sûreté Pour Soudage A L'Arc

1. Protégez-vous contre la secousse électrique:
 - a. Les circuits à l'électrode et à la pièce sont sous tension quand la machine à souder est en marche. Eviter toujours tout contact entre les parties sous tension et la peau nue ou les vêtements mouillés. Porter des gants secs et sans trous pour isoler les mains.
 - b. Faire très attention de bien s'isoler de la masse quand on soude dans des endroits humides, ou sur un plancher métallique ou des grilles métalliques, principalement dans les positions assis ou couché pour lesquelles une grande partie du corps peut être en contact avec la masse.
 - c. Maintenir le porte-électrode, la pince de masse, le câble de soudage et la machine à souder en bon et sûr état de fonctionnement.
 - d. Ne jamais plonger le porte-électrode dans l'eau pour le refroidir.
 - e. Ne jamais toucher simultanément les parties sous tension des porte-électrodes connectés à deux machines à souder parce que la tension entre les deux pinces peut être le total de la tension à vide des deux machines.
 - f. Si on utilise la machine à souder comme une source de courant pour soudage semi-automatique, ces précautions pour le porte-électrode s'appliquent aussi au pistolet de soudage.
2. Dans le cas de travail au dessus du niveau du sol, se protéger contre les chutes dans le cas où on reçoit un choc. Ne jamais enrouler le câble-électrode autour de n'importe quelle partie du corps.
3. Un coup d'arc peut être plus sévère qu'un coup de soleil, donc:
 - a. Utiliser un bon masque avec un verre filtrant approprié ainsi qu'un verre blanc afin de se protéger les yeux du rayonnement de l'arc et des projections quand on soude ou quand on regarde l'arc.
 - b. Porter des vêtements convenables afin de protéger la peau de soudeur et des aides contre le rayonnement de l'arc.
 - c. Protéger l'autre personnel travaillant à proximité au soudage à l'aide d'écrans appropriés et non-inflammables.
4. Des gouttes de laitier en fusion sont émises de l'arc de soudage. Se protéger avec des vêtements de protection libres de l'huile, tels que les gants en cuir, chemise épaisse, pantalons sans revers, et chaussures montantes.
5. Toujours porter des lunettes de sécurité dans la zone de soudage. Utiliser des lunettes avec écrans latéraux dans les

zones où l'on pique le laitier.

6. Eloigner les matériaux inflammables ou les recouvrir afin de prévenir tout risque d'incendie dû aux étincelles.
7. Quand on ne soude pas, poser la pince à un endroit isolé de la masse. Un court-circuit accidentel peut provoquer un échauffement et un risque d'incendie.
8. S'assurer que la masse est connectée le plus près possible de la zone de travail qu'il est pratique de le faire. Si on place la masse sur la charpente de la construction ou d'autres endroits éloignés de la zone de travail, on augmente le risque de voir passer le courant de soudage par les chaînes de levage, câbles de grue, ou autres circuits. Cela peut provoquer des risques d'incendie ou d'échauffement des chaînes et des câbles jusqu'à ce qu'ils se rompent.
9. Assurer une ventilation suffisante dans la zone de soudage. Ceci est particulièrement important pour le soudage de tôles galvanisées plombées, ou cadmiées ou tout autre métal qui produit des fumées toxiques.
10. Ne pas souder en présence de vapeurs de chlore provenant d'opérations de dégraissage, nettoyage ou pistologie. La chaleur ou les rayons de l'arc peuvent réagir avec les vapeurs du solvant pour produire du phosgène (gas fortement toxique) ou autres produits irritants.
11. Pour obtenir de plus amples renseignements sur la sûreté, voir le code "Code for safety in welding and cutting" CSA Standard W 117.2-1974.

PRÉCAUTIONS DE SÛRETÉ POUR LES MACHINES À SOUDER À TRANSFORMATEUR ET À REDRESSEUR

1. Relier à la terre le châssis du poste conformément au code de l'électricité et aux recommandations du fabricant. Le dispositif de montage ou la pièce à souder doit être branché à une bonne mise à la terre.
2. Autant que possible, l'installation et l'entretien du poste seront effectués par un électricien qualifié.
3. Avant de faire des travaux à l'intérieur de poste, la débrancher à l'interrupteur à la boîte de fusibles.
4. Garder tous les couvercles et dispositifs de sûreté à leur place.

MASTER TABLE OF CONTENTS FOR ALL SECTIONS

Safety	i-iv
Installation PF-10M Single	Section A
Installation PF-10M Dual	Section AA
Operation PF-10M Single	Section B
Operation PF-10M Dual	Section BB
Accessories PF-10M Single	Section C
Accessories PF-10M Dual	Section CC
Maintenance PF-10M Single	Section D
Maintenance PF-10M Dual	Section DD
Theory of Operation	Section E
Troubleshooting and Repair	Section F
Electrical Diagrams	Section G
Parts Manual	P497 Series (PF-10M Single) P468 Series (PF-10M Dual)

TABLE OF CONTENTS - INSTALLATION SECTION -

Return to Master TOC

Return to Master TOC

Return to Master TOC

Return to Master TOC

InstallationSection A

Technical SpecificationsA-2

Safety PrecautionsA-3

 LocationA-3

 MountingA-3

Safety PrecautionsA-4

 Weld Cable SizingA-4

 Weld Cable ConnectionA-4

 Weld Cable SizesA-4

 Electrode LeadA-4

 Coaxial Weld CablesA-5

Changing Electrode Polarity SettingA-5

 Negative Electrode PolarityA-5

Control CableA-6

 Control Cable ConnectionsA-6

 Control Cable SpecificationsA-6

 Available Control CableA-6

Wire Drive SystemsA-7

 Changing Drive Rolls and Wire GuidesA-7

 Drive Roll Pressure SettingA-8

 Changing the Gun Receiver BushingA-8

 Welding Guns, Torches and AccessoriesA-9

 Wire Feed Shut Down CircuitA-10

 Changing the Gear RatioA-10/A-11

 Wire Reel LoadingA-11/A-12

 Weld Wire RoutingA-13

Shielding Gas ConnectionA-14

Examples of Connecting an Arclink Power Wave SystemA-15



TECHNICAL SPECIFICATIONS: Power Feed 10M Single Wire Feeder

WIRE DRIVE OR WIRE DRIVE SECTION OF FEEDER							
SPEC.#	TYPE	LOW SPEED RATIO			HIGH SPEED RATIO		
		Low Speed	Wire Size		High Speed	Wire Size	
	Solid		Cored			Solid	Cored
K2230-1 K2314-1	Bench Model Boom Model	50-800 IPM (1.27-20.3 m/m)	.025 - 3/32 in. (0.6 - 2.4 mm)	.035 - .120 in (0.9 - 3.0 mm)	75 - 1200 IPM (2.0 - 30.5 m/m)	.025 - 1/16 in. (0.6 - 1.6 mm)	.035 - 5/64 in. (0.9 - 2.0 mm)

CONTROL BOX, WIRE DRIVE AND COMPLETE UNITS								
SPEC.#	TYPE	INPUT POWER	PHYSICAL SIZE*			TEMPERATURE RATING		
			Dimensions			Weight	Operating	Storage
			Height	Width	Depth			
K2230-1 Bench Model Feeder	Wire Drive & Reel Stand	40VDC	18.5" (470 mm)	13.5" (345 mm)	30.5" (775 mm)	62 Lbs (28.1 Kg.)	14°F to 140°F (-10°C to 40°C)	-40°F to 185°F (-40°C to 40°C)
K2314-1 Boom Model Feeder	Control Box only		Dimensions Δ			Weight		
			Height	Width	Depth	Weight		
			13.0" (330 mm)	8.5" (215 mm)	4.0" (105 mm)	8.5 Lbs (3.8 Kg.)		
K2314-1 Boom Model Feeder	Wire Drive Unit only		Dimensions Δ			Weight		
			Height	Width	Depth	Weight		
			7.6" (195 mm)	12.9" (325 mm)	13.7" (345 mm)	30 Lbs (13.6 Kg.)		

WELDING CAPACITY RATING	
Amp Rating	Duty Cycle
600 A	60%
500 A	100%

Δ Dimensions do not include wire reel.

POWER FEED 10M SINGLE/DUAL



Return to Section TOC

Return to Master TOC

Return to Section TOC

Return to Master TOC

Return to Section TOC

Return to Master TOC

Return to Section TOC

Return to Master TOC

SAFETY PRECAUTION



ELECTRIC SHOCK can kill.

- Only qualified personnel should perform this installation.
- Turn off the input power to the power source at the disconnect switch or fuse box before working on this equipment. Turn off the input power to any other equipment connected to the welding system at the disconnect switch or fuse box before working on this equipment.

- Do not touch electrically hot parts.

LOCATION

- The Power Feed 10M Single Wire Feeder has an IP21 rating, suitable for indoor use.
- The Power Feed 10M Single Wire Feeder should be operated in a substantially upright position.
- Do not submerge the Power Feed 10M Single Wire Feeder.
- The Power Feed 10M Single Wire Feeder is not suitable for stacking.

Locate the Power Feed 10M Single Wire Feeder away from radio controlled machinery. The normal operation of the Power Feed 10M Single Wire Feeder may adversely affect the operation of RF controlled equipment, which may result in bodily injury or damage to the equipment.

FIGURE A.1

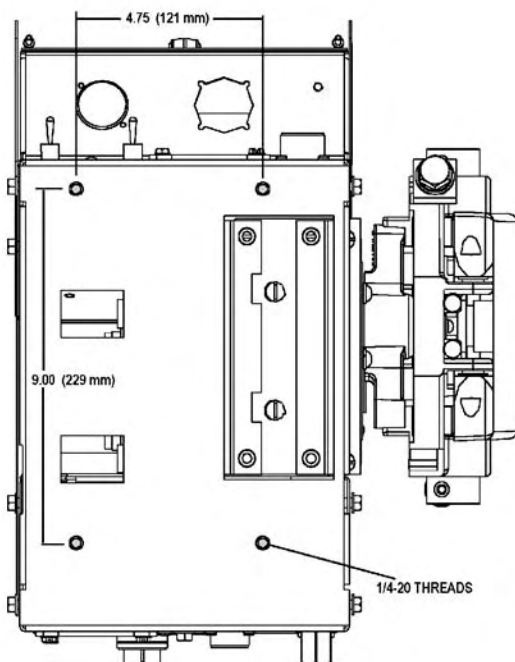

MOUNTING

Wire Drive Mounting (See Figure A.1)

The wire drive may be mounted by using the four holes on the bottom. Because the feed plate and gearbox are electrically "hot" when welding, make certain the parts do not contact the any structure or person.

Mount the wire drive with the drive rolls in the vertical plane to prevent dirt from collecting in the wire drive. Angle the drive and feed plate to prevent sharp bends in the gun and cable and incoming wire.

Control Box Mounting (See Figure A.2)

Boom model Power Feed 10M Single Wire Feeder's feature a control box that mounts separately from the wire drive.

The back of the control box has four keyhole slots for mounting. #10 screws are recommended for mounting.

FIGURE A.2

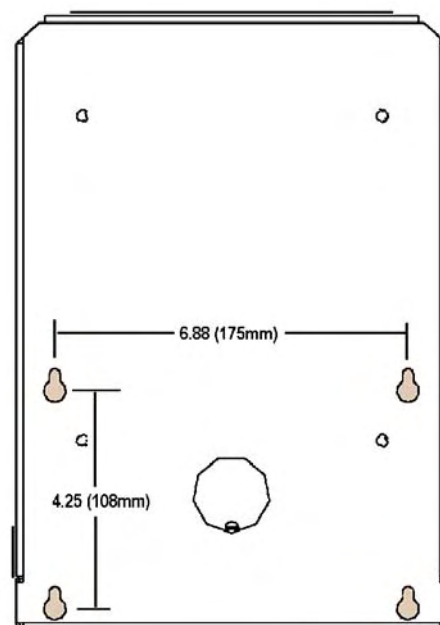

POWER FEED 10M SINGLE/DUAL



SAFETY PRECAUTION



ELECTRIC SHOCK can kill.

- Only qualified personnel should perform this installation.
- Turn off the input power to the power source at the disconnect switch or fuse box before working on this equipment. Turn off the input power to any other equipment connected to the welding system at the disconnect switch or fuse box before working on this equipment.

- Do not touch electrically hot parts.

WELD CABLE SIZING

Minimum work and electrode cables sizes are as follows:

TABLE A.1

(Current (60% Duty Cycle))	MINIMUM COPPER WORK CABLE SIZE AWG
	Up To-100 Ft. Length (30 m)
400 Amps	2/0 (67 mm ²)
500 Amps	3/0 (85 mm ²)
600 Amps	3/0 (85 mm ²)

NOTE: K1796 coaxial welding cable is recommended to reduce the cable inductance in long distance Pulse or STT applications up to 300 amps.

WELD CABLE CONNECTION

Connect a work lead of sufficient size and length (**Per Table A.1**) between the proper output terminal on the power source and the work. Be sure the connection to the work makes tight metal-to-metal electrical contact. To avoid interference problems with other equipment and to achieve the best possible operation, route all cables directly to the work or wire feeder. Avoid excessive lengths and do not coil excess cable.

CAUTION

When using an inverter type power source like the Power Waves, use the largest welding (electrode and work) cables that are practical. At least 2/0 copper wire - even if the average output current would not normally require it. When pulsing, the pulse current can reach very high levels. Voltage drops can become excessive, leading to poor welding characteristics, if undersized welding cables are used.

WELD CABLE SIZES

Table A.2 has the copper cable sizes recommended for different currents and duty cycles. Lengths stipulated are the distance from the welder to work and back to the welder again. Cable sizes are increased for greater lengths primarily for the purpose of minimizing voltage in the welding circuit.

ELECTRODE LEAD

Most welding applications run with the electrode being positive (+). For those applications, connect the electrode cable between the wire feeder and the positive (+) output stud on the power source. Connect the lug at the other end of the electrode cable to the wire drive feed plate. Be sure the connection to the feed plate makes tight metal-to-metal electrical contact. The electrode cable should be sized according to the specifications given in the work cable connections **Table A.1**. Connect a work lead from the negative (-) power source output stud to the work piece. The work piece connection must be firm and secure, especially if pulse welding is planned.

TABLE A.2

RECOMMENDED CABLE SIZES (RUBBER COVERED COPPER - RATED 75°C)**						
Amperes	Percent Duty Cycle	CABLE SIZES FOR COMBINED LENGTHS OF ELECTRODE AND WORK CABLES				
		0 to 50 Ft.	50 to 100Ft.	100 to 150 Ft.	150 to 200 Ft.	200 to 250 Ft.
		0 to 15 m	15 to 31 m	31 to 48 m	48 to 61 m	61 to 76 m
325	100	2/0	2/0	2/0	2/0	3/0
350	60	1/0	1/0	2/0	2/0	3/0
400	60	2/0	2/0	2/0	3/0	4/0
400	100	3/0	3/0	3/0	3/0	4/0
500	60	2/0	2/0	3/0	3/0	4/0

** Tabled values are for operation at ambient temperatures of 40°C and below. Applications above 40°C may require cables larger than recommended, or cables rated higher than 75°C.

POWER FEED 10M SINGLE/DUAL



Return to Section TOC
Return to Master TOC

For Electrode Polarity:	Connect the Electrode lead to	Connect the work lead to
Positive	Positive Stud	Negative
Negative	Negative Stud	Positive Stud

For additional Safety information regarding the electrode and work cable set-up, See the standard "SAFETY INFORMATION" located in the front of the Instruction Manuals.



CAUTION

Excessive voltage drops caused by poor work piece connections often result in unsatisfactory welding performance.

COAXIAL WELD CABLES

Coaxial welding cables are specially designed welding cables for pulse welding or STT welding. Coaxial weld cables feature low inductance, allowing fast changes in the weld current. Regular cables have a higher inductance which may distort the pulse or STT wave shape. Inductance becomes more severe as the weld cables become longer.

Coaxial weld cables are recommended for all pulse and STT welding, especially when the total weld cable length (electrode cable + work cable) exceeds 50 feet (7.6m)

A coaxial weld cable is constructed by 8 small leads wrapped around one large lead. The large inner lead connects to the electrode stud on the power source and the electrode connection on the wire feeder. The small leads combine together to form the work lead, one end attached to the power source and the other end to the work piece. (See Coaxial weld Cable below.)

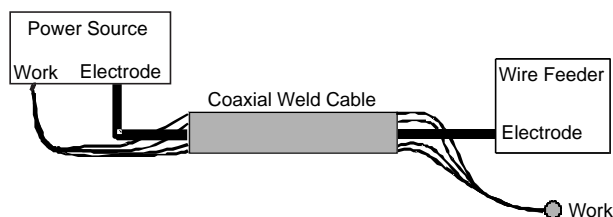
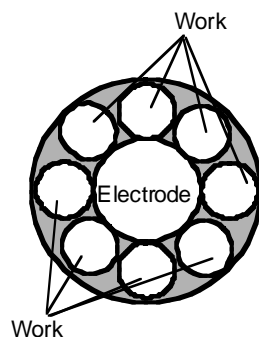

POWER FEED 10M SINGLE/DUAL



CHANGING ELECTRODE POLARITY SETTING

The Power Feed 10M Single Wire Feeder is preset at the factory for Electrode Positive welding. (See Figure A.3)

NOTE: Changing this DIP Switch does not change the actual welding polarity. The actual welding polarity is changed by reversing the welding cables at the power source output studs.

This DIP Switch setting must coincide with the polarity you are setting up to weld with for the feeder to operate correctly. Operating the Power Feed 10M Single Wire Feeder with the DIP switch in the wrong position will cause very erratic weld characteristics.

NEGATIVE ELECTRODE POLARITY

This options allows for the setting of negative polarity sensing when a negative polarity welding process is performed.

When negative electrode polarity is required, such as in some Innershield applications, reverse the output connections at the power source (electrode cable to the negative (-) stud, and work cable to the positive (+) stud).

When operating with electrode polarity negative the Power Feed 10M Single Wire Feeder must be set to recognize this set-up. (See Figure A.3)

To change the electrode polarity DIP Switch setting:

WARNING



- Do not touch electrically live parts or electrodes with your skin or wet clothing.
- Insulate yourself from the work and ground.

- Always wear dry insulating gloves.

1. Turn off power at the welding power source.
2. Remove the rear access panel on the wire drive.
3. Locate the DIP switches on the Wire Drive Board.
4. Set DIP switch #7 to the desired polarity.
5. Reinstall the rear access panel and restore power.

DIP Switch #7 Position	Polarity
ON	(negative) - polarity
OFF	(positive) + polarity

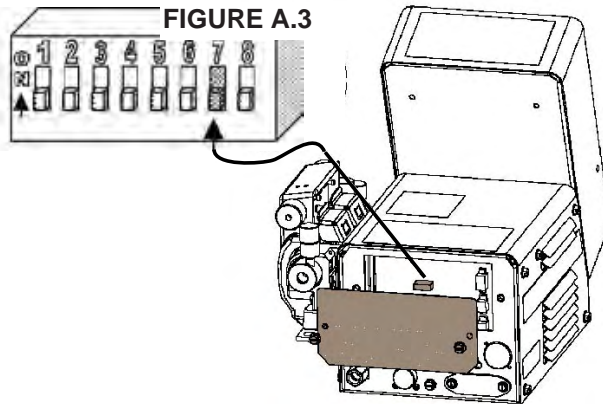

Welding Gun/Wire Feeder Trigger Connector

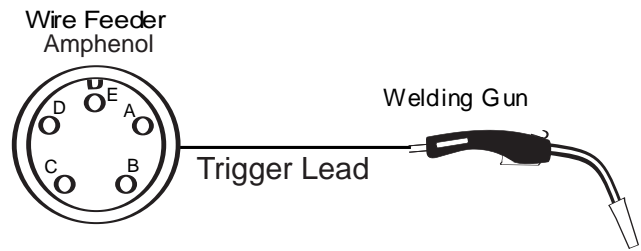

Wire Feeder	
Pin	Function
A	Gun Trigger
B	-
C	Common
D	Dual Procedure
E	Common

**CONTROL CABLE
CONTROL CABLE CONNECTIONS**

- All system control cables are the same.
- All control cables can be connected end to end to extend their length.
- All system equipment must be connected to a control cable.

Typical Bench Feeder Connection:

Control cable is connected from the Power Wave Source output Amphenol receptacle to the input Amphenol receptacle on the back of the Wire Drive.

Digital Control Cable, K1543-xx



Pin	Function
A	Digital I/O
B	Digital I/O
C	"67" voltage sense
D	40 VDC
E	40 VDC

Use a maximum of 250 feet (76.2m) of control cable between components.

CONTROL CABLE SPECIFICATIONS

It is recommended that only genuine Lincoln control cables be used at all times. Lincoln cables are specifically designed for the communication and power needs of the Power Wave Source / Power Feed system. The use of non-standard cables, especially in lengths greater than 25ft(7.6m), can lead to communication problems (system shutdowns), poor motor acceleration (poor arc starting) and low wire driving force (wire feeding problems).

Lincoln control cables are copper 5 conductor cable in a SO-type rubber jacket. There is one 20 gauge twisted pair for network communications. This pair has an impedance of approximately 120 ohms and a propagation delay per foot of less than 2.1 nanoseconds. There are two 12 gauge conductors that are used to supply the 40 VDC to the network. The fifth wire is 18 gauge and is used as an electrode sense lead.

AVAILABLE CONTROL CABLE

K1543 Control cable only. Available in lengths of 8'(2.4m), 16'(4.9m), 25'(7.6m), 50'(15.2m) and 100'(30.5m).

Return to Section TOC
Return to Master TOC
Return to Section TOC
Return to Master TOC
Return to Section TOC
Return to Master TOC
Return to Section TOC
Return to Master TOC

WIRE DRIVE SYSTEMS

Drive Roll Kits are designed to feed specific types and wire sizes. The Power Feed 10M Single Wire Feeder does not include these Drive Roll Kits with this Wire Drive, but are available for ordering from the following tables:

Drive Roll Kits, Steel Wires	
Includes: 4 Smooth V groove drive rolls and an inner wire guide.	
KP1505-030S	.023-.030 (0.6-0.8mm)
KP1505-035S	.035 (0.9mm)
KP1505-045S	.045 (1.2mm)
KP1505-052S	.052 (1.4mm)
KP1505-1/16S	1/16 (1.6mm)

Drive Roll Kits, Cored Wires	
Includes: 4 Knurled drive rolls and an inner wire guide.	
KP1505-035C	.030-.035" (0.8-0.9mm)
KP1505-045C	.040-.045" (1.0-1.2mm)
KP1505-052C	.052" (1.4mm)
KP1505-1/16C	1/16" (1.6mm)

Drive Roll Kits, Steel or Cored Wires	
Includes: 4 Knurled drive rolls and an inner wire guide.	
KP1505-068	.068-.072" (1.8mm)
KP1505-5/64	5/64" (2.0mm)
KP1505-3/32	3/32" (2.4mm)
KP1505-7/64	7/64" (2.8mm)
KP1505-.120	.120" (3.2mm)

Drive Roll Kits, Hardfacing Wires	
Includes: 2 Knurled drive rolls, 2 Smooth V groove drive rolls and an inner wire guide.	
KP1505-7/64C	7/64" (2.8mm)

Drive Roll Kits, Aluminum Wire	
Includes: 4 polished U groove drive rolls, outer wire guide and an inner wire guide.	
KP1507-035A	.035" (0.9 mm)
KP1507-040A	.040" (1.0mm)
KP1507-3/64A	3/64" (1.2mm)
KP1507-1/16A	1/16" (1.6mm)
KP1507-3/32A	3/32" (2.4mm)



CHANGING DRIVE ROLLS AND WIRE GUIDES

FIGURE A.4

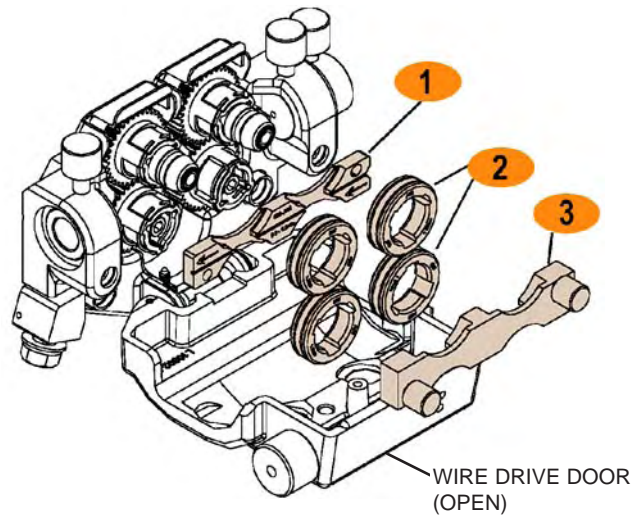

ITEM	DESCRIPTION
1	Inner Wire Guide
2	Drive Rolls
3	Outer Wire Guide

To change drive rolls and wire guides:

1. Turn off power at the welding power source.
2. Open wire drive door.
3. Remove the outer wire guide. (Item #3)
4. Remove the 4 drive rolls (Item #2) by pulling them straight off of the drive hub. Rock the upper drive rolls back for ease of removal.
5. Remove the inner wire guide (Item #1).
6. Insert the new inner wire guide (Item #1) over the locating pins of the feed plate.
7. Install each drive roll by pushing it onto the hub until it fully seats.
8. Install the outer wire guide.
9. Swing the upper drive rolls down and close the wire drive door.

[Return to Section TOC](#) | [Return to Master TOC](#)

DRIVE ROLL PRESSURE SETTING

The Power Feed 10M Single Wire Feeder is factory set with the pressure indicator approximately "2". The best drive roll pressure varies with wire type, wire surface, lubrication and hardness. Too much pressure could cause "birdnesting", but too little pressure could cause slippage.

Set the drive roll pressure by:

1. Press the end of the gun against a solid object that is electrically isolated from the welder output and press the gun trigger for several seconds.
2. If the wire "birdnests" or jams, the drive roll pressure is too high. Reduce the pressure by one turn of the knob, run new wire through the gun, and repeat step 1.
3. If the only result is slippage, disconnect the gun and pull the gun cable forward about 6" (150mm). There should be a slight waviness in the exposed wire. If there is no waviness, increase the pressure setting one turn, reconnect the gun and repeat the above steps.

CHANGING THE GUN RECEIVER BUSHING

Gun receiver bushings make it easy to switch from one gun to another.

Tools required:
1/4" Allen wrench

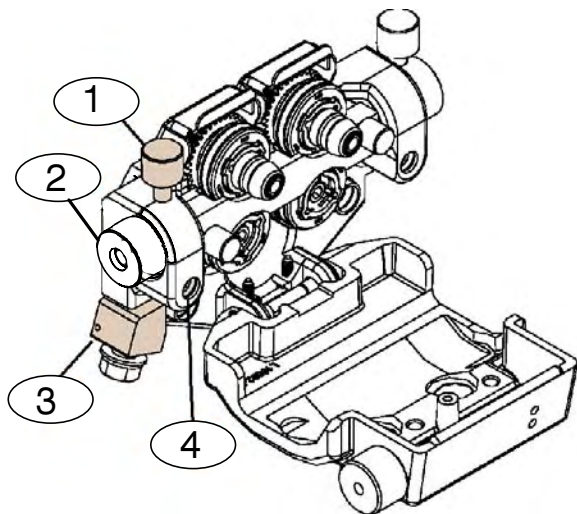

FIGURE A.5

ITEM	DESCRIPTION
1	Thumb Screw
2	Gun Receiver Bushing
3	Connector Bar
4	Socket Head Cap Screw

To change the gun bushing:

1. Turn off power at the welding power source.
2. Remove the welding wire from the wire drive.
3. Remove the thumb screw from the wire drive.
4. Remove the welding gun from the wire drive.
5. Loosen the socket head cap screw that holds the connector bar against the gun bushing. Important: Do not attempt to completely remove the socket head cap screw.
6. Remove the outer wire guide, and push the gun bushing out of the wire drive. Because of the precision fit, light tapping may be required to remove the gun bushing.
7. Disconnect the shielding gas hose from the gun bushing, if required.
8. Connect the shielding gas hose to the new gun bushing, if required.
9. Rotate the gun bushing until the thumb screw hole aligns with the thumb screw hole in the feed plate. Slide the gun receiver bushing into the wire drive and verify the thumb screw holes are aligned.
Note: Some gun bushings do not require the use of the thumb screw.
10. Tighten the socket head cap screw.
11. Insert the welding gun into the gun bushing and tighten the thumb screw.

Gun Receiver Bushing	For use With
K1500-1	K466-1 Lincoln gun connectors; Innershield and Subarc guns)
K1500-2	K466-2, K466-10 Lincoln gun connectors; Magnum 200/300/400 guns and compatible with Tweco® #4)
K1500-3	K1637-7 Lincoln gun connectors; Magnum 550 guns and compatible with Tweco® #5)
K1500-4	K466-3 Lincoln gun connectors; compatible with Miller® guns.)
K1500-5	(Compatible with Oxo® guns.)
K489-7	(Lincoln Fast-Mate guns.)

POWER FEED 10M SINGLE/DUAL



Return to Section TOC
Return to Master TOC

WELDING GUNS, TORCHES AND ACCESSORIES

GUN RECEIVER BUSHING

The Power Feed 10M Single Wire Feeder comes with a K1500-2 gun receiver bushing, for use with the Magnum gun with a K466-10 connector kit which .

The Power Feed 10M Single Wire Feeder Push Pull model comes with a S25398 gun receiver bushing, for use with the push pull gun. K2154-1 push-pull torch connector kit is optional.

The bushing must be changed if the Power Feed 10M Single Wire Feeder is going to be switched from the push set up to the push-pull set up or vice versa.

Spool Guns are not recommended with the Power Feed 10M Single Wire Feeder.

MAGNUM GUN AND CABLE ASSEMBLIES

The Power Feed 10M Single Wire Feeder model will accept a number of optional gun and cable assemblies. An example of installing the Gun and Cable is shown in **Figure A.5a** with a 15 ft. (4.6m) long Magnum gun and cable.

1. Turn off power at the welding power source.
2. Unscrew Thumb screw on Wire Drive Unit, until tip of screw no longer protrudes into gun bushing hole as seen from the front of machine.
3. Fully insert the gun cable connector end into the gun receiver bushing and gently tighten the thumb screw as show in Figure A.5a below.
4. Connect the gun trigger connector to the trigger receptacle. Make sure that the key ways are aligned, insert and tighten retaining ring.

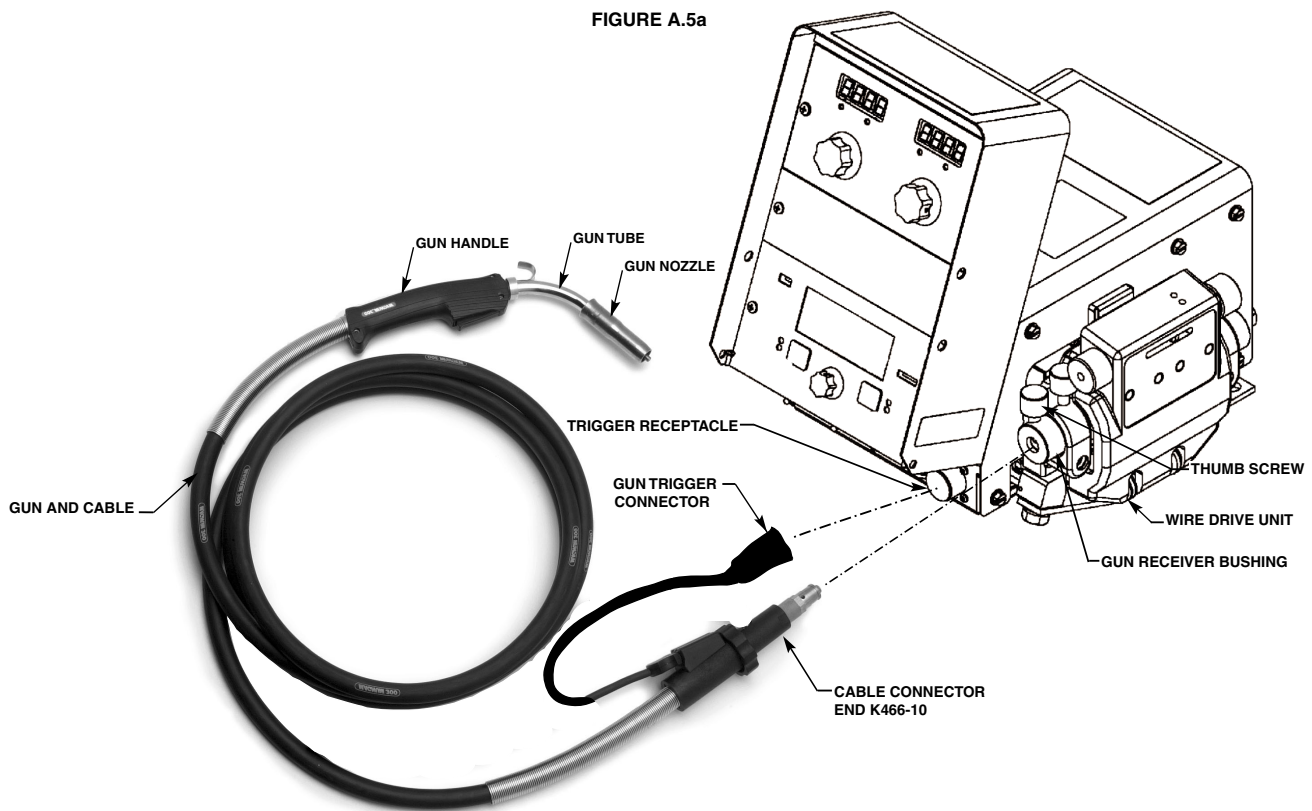

POWER FEED 10M SINGLE/DUAL



Return to Section TOC
Return to Master TOC
Return to Section TOC
Return to Master TOC
Return to Section TOC
Return to Master TOC
Return to Section TOC
Return to Master TOC

WIRE FEED SHUT DOWN CIRCUIT

The wire feed shut down circuit is used to stop the wire feed in the event of a fault. The most common use of the circuit is with water cooled guns. A flow sensor is connected to the circuit to protect the welding gun if the water flow is interrupted.

The Power Feed 10M Single Wire Feeder has two leads, 570A and 570B, located inside the wire drive that are electrically common. If flow switch is used, separate these leads and connect to normally closed flow switch terminals when water is flowing. Connect the flow sensor to these two leads.

CHANGING THE GEAR RATIO

The Power Feed 10M Single Wire Feeder wire drive may be configured for either low speed or high speed, depending upon the application. The wire feeders are factory assembled for low speed operation and include a gear for high speed operation.

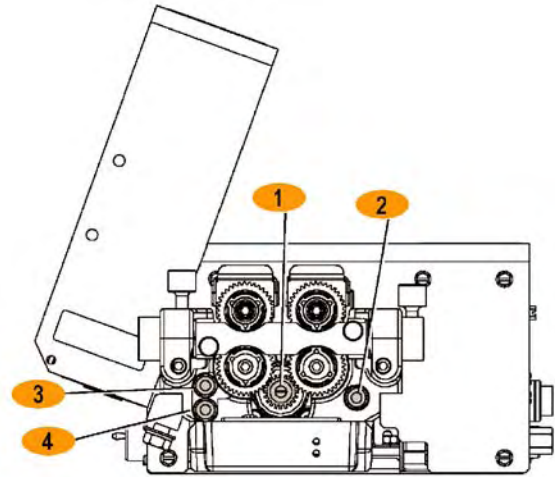

FIGURE A.6

ITEM	DESCRIPTION
1	Gear.
2	Screw holding feed plate to wire feeder.
3	Low speed position, screw holding feed plate to wire feeder.
4	High speed position, screw holding feed plate to wire feeder.

Gear Ratio	Purpose:	Speed	Wire Size	
			Solid	Core
Low Speed	Best for most GMAW and FCAW welding. The low speed gear ratio provides the most force for pushing wires through long guns or pulling wire through conduits.	50-800 ipm (1.27-20.3 m/m)	.025-3/32 in. (0.6 - 2.4 mm)	.035 - .120 in. (0.9 - 3.0 mm)
High Speed	Suitable only for small diameter wires operating at high wire feed speeds. Feeding force is less.	75-1200 ipm (2.03-30.5 m/m)	.025-1/16 in. (0.6 - 1.6 mm)	.035 - 5/64 in. (0.9 - 2.0 mm)

To change the gear ratio:

1. Turn off power at the welding power source.
2. Open the wire drive door.
3. Use a 3/16" Allen wrench to remove the screws holding the feed plate to the wire feeder.
4. Use a Phillips screwdriver to remove the screw and washers holding the gear to the shaft.
5. Remove the gear.
6. Lightly cover the shaft with engine oil or equivalent. Install the desired gear onto the shaft.
7. Reassemble the screw and washers securing the gear to the shaft.
8. Reassemble the screws in the appropriate position for holding the feed plate to the wire feeder.

Return to Section TOC
 Return to Master TOC
 Return to Section TOC
 Return to Master TOC
 Return to Section TOC
 Return to Master TOC
 Return to Section TOC
 Return to Master TOC

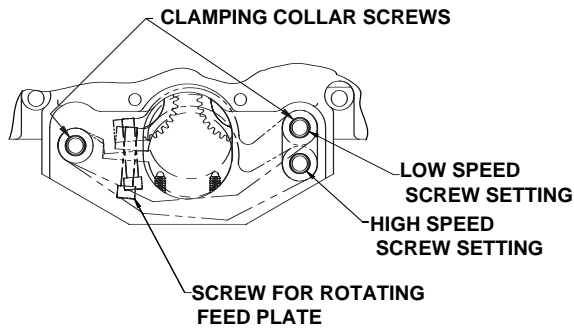

9. Loosen the two screws on the bottom of the feed plate clamping collar.
10. Rotate the feed plate to the desired position.
11. Tighten the two screws on the bottom of the feed plate clamping collar.

FIGURE A.7

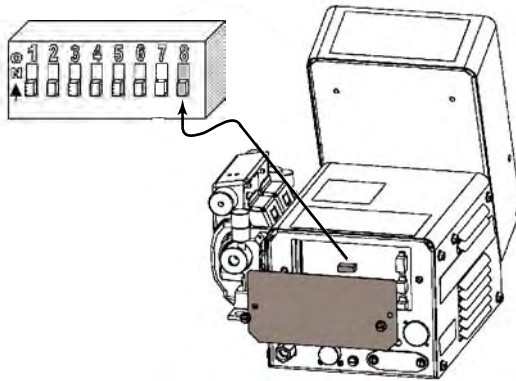

DIP Switch #8 Position	Gear Ratio
ON	High speed
OFF	Low speed (default)

12. Remove the rear access panel on the wire drive.
13. Locate DIP switches on the Wire Drive Board.
14. Set DIP switch #8 to the desired polarity.
15. Reinstall the rear access panel to the wire drive.
16. Restore power.

WIRE REEL LOADING

Spindle Placement

The wire reel stand provides two mounting locations for the spindle. Each mounting location consists of a tube in the center of the mast and locating slots.

Loading 16 to 44 lb. (7.3 – 20kg) Spools

1. Squeeze the release bar on the retaining collar and remove it from the spindle.
2. Place the spool on the spindle, aligning the spindle brake pin with one of the holes in the back side of the spool. An indicator mark on the end of the spindle shows the orientation of the brake holding pin. Be certain the wire feeds off of the spool in the proper direction.
3. Re-install the retaining collar. Make sure that the release bar snaps out and that the retaining collar fully engages the groove on the spindle.

Loading 10 to 15 lb. (4.5 – 6.8kg) Spools

A K419 spindle adapter is required for loading 2" wide spools on 2" (51mm) spindles. Use a K419-1 spindle adapter for loading 2-1/2" (64mm) wide spools.

1. Squeeze the release bar on the retaining collar and remove it from the spindle.
2. Place the spindle adapter on the spindle, aligning the spindle brake pin with the hole in the adapter.
3. Place the spool on the spindle and align the adapter brake tab with one of the holes in the back side of the spool. An indicator mark on the end of the spindle shows the orientation of the brake tab. Be certain the wire feeds off of the spool in the proper direction.
4. Re-install the retaining collar. Make sure that the release bar snaps out and that the retaining collar fully engages the groove on the spindle.

Using K1504-1 Coil Reel

50-60 lb. (22.7 - 27.2 kg) Coil Mounting

(See Figure A.10)

1. Make sure the spindle of the wire reel stand is in the upper position.
2. With the coil reel assembly mounted to a 2" (51mm) spindle, loosen the spinner nut and remove the cover plate. Alternatively, lay the coil reel assembly flat on the floor and loosen the spinner nut and remove the cover plate.
3. Place the coil of electrode on the reel so it unwinds from the bottom as it rotates.
4. Tighten the spinner nut as much as possible by hand using the cover plate spokes for leverage. DO NOT hammer on the spinner nut.
5. Cut and remove only the tie wire holding the free end of the coil. Hook the free end around the rim of the cover plate and secure it by wrapping it around. Cut and remove remaining tie wires.

⚠ CAUTION

- Always be sure the free end of the coil is securely held while the tie wires are being cut and until the wire is feeding through the drive rolls. Failure to do this will result in "backlashing" of the coil, which may tangle the wire. A tangled coil will not feed and must either be untangled or discarded.

6. Be sure the coil is engaged with the spindle brake pin and the release bar on the retaining collar "pops up". The retaining collar must fully engage the retaining groove on the spindle.

FIGURE A.10

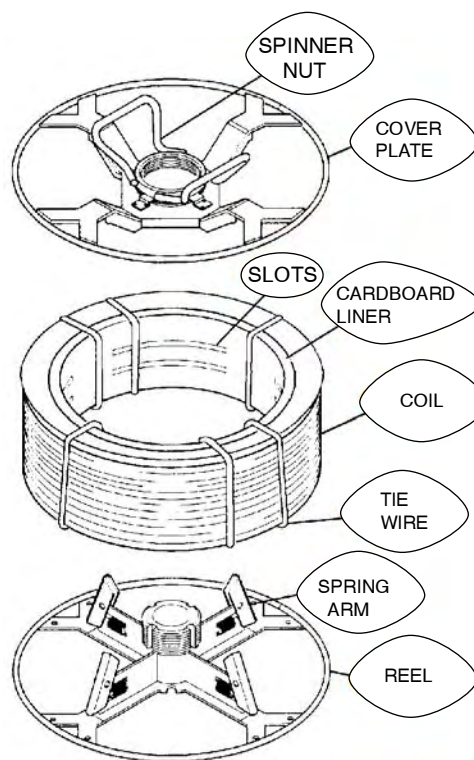

Loading 30 lb. (13.6 kg) Readi-Reels (See Figure A.11)

A K363-P Readi-Reel adapter is required for loading these spools on 2" (51mm) spindles.

1. Squeeze the release bar on the retaining collar and remove it from the spindle.
2. Place the Readi-Reel adapter on the spindle, aligning the spindle brake pin with one of the holes in the adapter.
3. Re-install the retaining collar. Make sure that the release bar snaps out and that the retaining collar fully engages the groove on the spindle.
4. Rotate the spindle and adapter until the retaining spring is at the 12 o'clock position.
5. Position the Readi-Reel so that electrode de-reels in the proper direction.
6. Set one of the Readi-Reel inside cage wires on the slot in the retaining spring.
7. Lower the Readi-Reel to depress the retaining spring and align the other inside cage wires with the grooves in the adapter.
8. Slide the cage all way onto the adapter until the retaining spring "pops up" fully.

Removing a Readi-Reel

1. To remove a Readi-Reel from the an adapter, depress the retaining spring with a thumb while pulling the Readi-Reel cage from the adapter with both hands. Do not remove the adapter from the spindle.

WELD WIRE ROUTING

The electrode supply may be either from reels, Readi-Reels, spools, or bulk packaged drums or reels. Observe the following precautions:

- a) The electrode must be routed to the wire drive unit so that the bends in the wire are at a minimum, and also that the force required to pull the wire from the reel into the wire drive unit is kept at a minimum.
- b) The electrode is "hot" when the gun trigger is pressed and must be insulated from the boom and structure.
- c) If more than one wire feed unit shares the same boom and are not sharing the some power source output stud, their wire and reels must be insulated from each other as well as insulated from their mounting structure.

FIGURE A.11

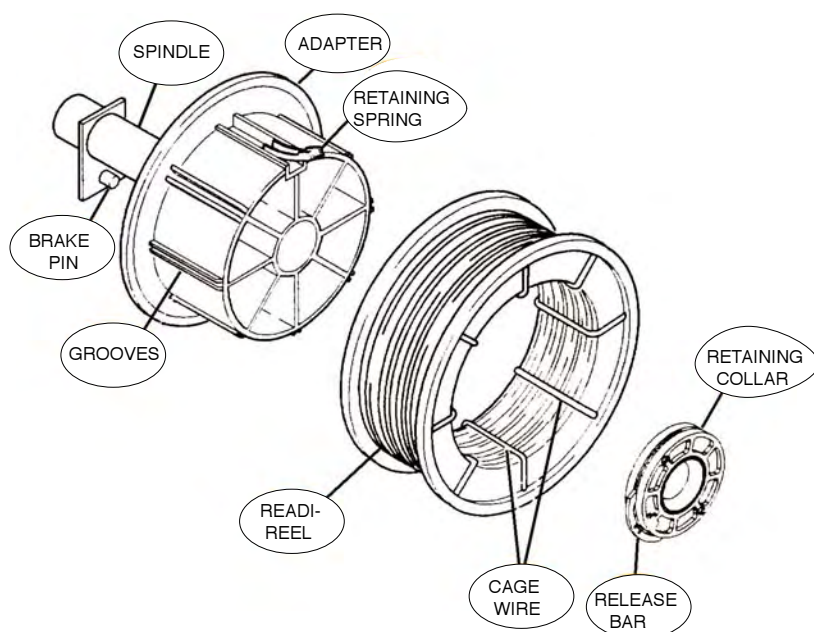

POWER FEED 10M SINGLE/DUAL



SHIELDING GAS CONNECTION

NOTE: Gas supply pressure must be regulated to a maximum of 80 psi(5.5 bar).

Install the shielding gas supply as follows:

1. Secure the cylinder to prevent it from falling.
2. Remove the cylinder cap. Inspect the cylinder valves and regulator for damaged threads, dirt, dust, oil or grease. Remove dust and dirt with a clean cloth. **DO NOT ATTACH THE REGULATOR IF OIL, GREASE OR DAMAGE IS PRESENT!** Inform your gas supplier of this condition. Oil or grease in the presence of high pressure oxygen is explosive.
3. Stand to one side away from the outlet and open the cylinder valve for an instant. This blows away any dust or dirt which may have accumulated in the valve outlet.
4. Attach the flow regulator to the cylinder valve and tighten the union nut(s) securely with a wrench. Note: if connecting to 100% CO₂ cylinder, insert regulator adapter between regulator and cylinder valve. If adapter is equipped with a plastic washer, be sure it is seated for connection to the CO₂ cylinder.
5. Attach one end of the inlet hose to the outlet fitting of the flow regulator. Attach the other end to the welding system shielding gas inlet. Tighten the union nuts with a wrench.
6. Before opening the cylinder valve, turn the regulator adjusting knob counterclockwise until the adjusting spring pressure is released.
7. Standing to one side, open the cylinder valve slowly a fraction of a turn. When the cylinder pressure gage stops moving, open the valve fully.
8. The flow regulator is adjustable. Adjust it to the flow rate recommended for the procedure and process being used before making a weld.

POWER FEED 10M SINGLE/DUAL



EXAMPLES OF CONNECTING AN ARCLINK POWER WAVE SYSTEM

ArcLink Power Wave products may be configured in many different ways. The flexible system allows multiple wire feeders to be connected to the same power source. The diagrams represent some of the common methods for connecting ArcLink Products.

Important: Bench model wire feeders cannot be separated into a separate control box and wire drive for a boom system.

Common ArcLink Systems

The following Power Wave systems may all be assembled without any changes to the equipment DIP switches.

Basic Semi-Automatic System

- Great for general fabrication.

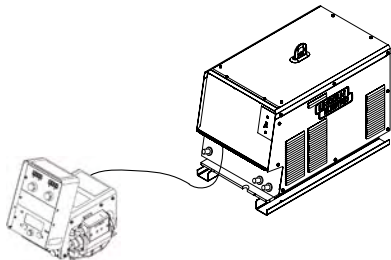

Shown with

- K2230-1 Power Feed 10M Single Wire Feeder
- K2203-1 Power Wave 455M/STT

Boom Semi-Automatic System

- Often used when making large weldments.

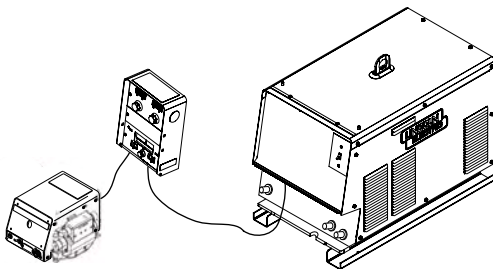

Shown with

- K2314-1 Power Feed 10M Single Wire Feeder Boom (includes wire drive and control box)
- K2203-1 Power Wave 455M/STT

Robotic/Semi-Automatic System

- Use the bench feeder for offline welding.

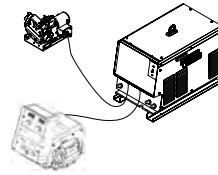

Shown with

- K2230-1 Power Feed 10M Single Wire Feeder
- K1780-2 PF-10/R
- K2203-1 Power Wave 455M/STT
- K2205-1 Wire Drive Module

Multiple Wire Feeder System

- Load one feeder with solid wire, the other with flux cored.

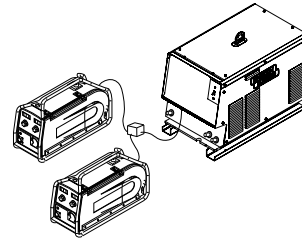

- Great for pipeline work.

Shown with

- K2429-1 ArcLink T Cable Connector
- K2196-1 Power Feed 15M
- K2203-1 Power Wave 455M/STT

ArcLink Systems

Many other ArcLink systems may be assembled besides those shown in this manual. The majority will self configure. If an assembled system flashes the status light green rapidly on all components, contact the Lincoln Electric Company for further assistance.

Current Power Feed 10M models that will not self configure...

- K2316-1 Power Feed 10M Dual Boom

These configurations will require Dip Switches to be set. See the power source instruction manual on how to disable self configuration.

POWER FEED 10M SINGLE/DUAL



INSTALLATION

BOOM CONFIGURATION

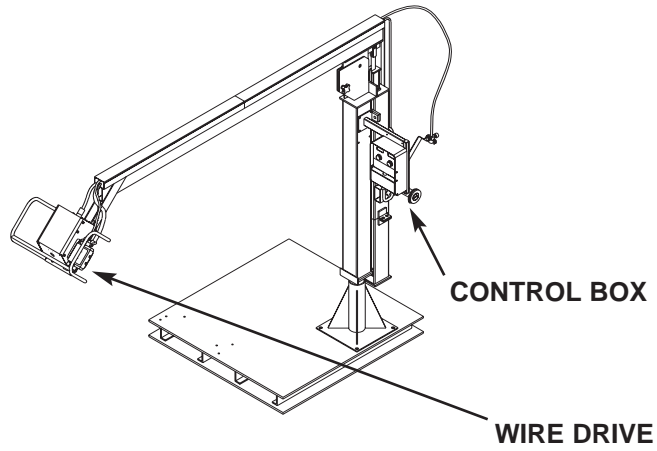

BENCH MODEL FEATURES

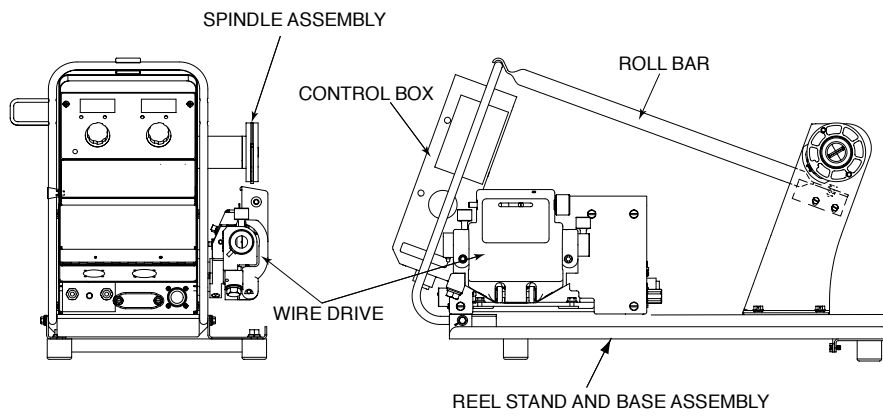

BASIC POWER FEED 10M SINGLE WIRE FEEDER WELDING SYSTEM CONFIGURATION

CV Welding:

Pulse Welding or STT Welding:

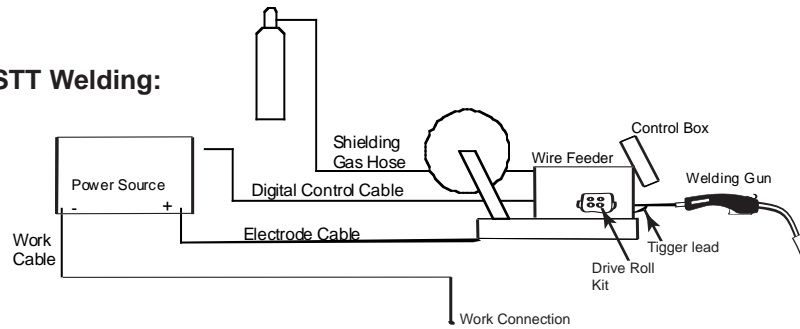

POWER FEED 10M SINGLE/DUAL



Return to Section TOC

Return to Master TOC

Return to Section TOC

Return to Master TOC

Return to Section TOC

Return to Master TOC

Return to Section TOC

Return to Master TOC

TABLE OF CONTENTS

- OPERATION SECTION -

OperationSection B

Safety Precautions	B-2
Graphic Symbols.....	B-2
Definitions of Welding Modes	B-3
Common Welding Abbreviations.....	B-3
Product Description.....	B-3
Recommended Processes	B-3/B-4
Required Equipment.....	B-4
Front Panel Controls and Connections.....	B-6
1. Status LED.....	B-6
2. Digital Meters and Output Encoder Knobs	B-6/B-8
A. Wire Feed Speed/Ammeter Display and Output Knob	B-6
B. Volts/Trim Display and Output Knob	B-7
Synergic CV Voltage Display	B-7
Overview:.....	B-8
3. Mode Select Panel 4 (MSP4).....	B-8
Layout-Controls.....	B-8
Layout-Digital Displays.....	B-8
Power-up Sequence.....	B-9
Changing Weld Modes.....	B-9
Changing Arc Wave Control.....	B-9
Changing Weld Sequence Behavior.....	B-9
Infrared (IR) Control	B-9
Lockout/Security	B-9
Limit Setting	B-10
Machine Setup/User Preferences	B-10
Accessing the Machine Setup Menu	B-10
Setup Features Menu	B-10/B-13
4. Cold Feed / Gas Purge Switch	B-13
5. 2-Step/4-Step Trigger Switch Operations	B-13 /B-15
Process Set-Up and Operation.....	B-16
Steel and Stainless Synergic GMAW-P (Pulsed MIG) Welding.....	B-17
Arc Control	B-17
Aluminum Synergic GMAW-P (Pulsed MIG) and GMAW-PP (Pulse on Pulse)	
Welding.....	B-18
Machine Functionality by Weld Process	B-19/B-24
CC-Stick	B-19
CV GMAW/FCAW (NON-SYNERGIC)	B-20
GMAW (SYNERGIC)	B-21
Pulse and Pulse-on-Pulse (SYNERGIC).....	B-22
STT and STT II (SYNERGIC)	B-23
GTAW (Touch Start TIG) Welding	B-24
User Memories.....	B-25
6. Optional Dual Procedure / Memory Panel Operation.....	B-25
Limit Setting.....	B-26

SAFETY PRECAUTIONS

Read this entire section of operating instructions before operating the machine.

WARNING



ELECTRIC SHOCK can kill.

- Do not touch electrically live parts or electrodes with your skin or wet clothing.
- Insulate yourself from the work and ground.
- Always wear dry insulating gloves.
- Do not use AC welder if your clothing, gloves or work area is damp or if working on, under or inside work-piece.



Use the following equipment:

- DC manual (stick) welder.
- AC welder with reduced voltage control.
- Do not operate with panels removed.
- Disconnect input power before servicing.

READ THIS WARNING, PROTECT YOURSELF & OTHERS.

FUMES AND GASES can be dangerous.



- Keep your head out of fumes.
- Use ventilation or exhaust at the arc, or both, to keep fumes and gases from your breathing zone and general area.

WELDING SPARKS can cause fire or explosion.



- Do not weld near flammable material.
- Do not weld on containers which have held flammable material.

ARC RAYS can burn.



- Wear eye, ear, and body protection.

ONLY QUALIFIED PERSONS SHOULD INSTALL, USE OR SERVICE THIS EQUIPMENT. READ AND FOLLOW THE MANUFACTURER'S INSTRUCTIONS, EMPLOYER'S SAFETY PRACTICES AND MATERIAL SAFETY DATA SHEETS (MSDS) FOR CONSUMABLES.

GRAPHIC SYMBOLS THAT APPEAR ON THIS MACHINE OR IN THIS MANUAL



WIRE FEEDER



POSITIVE OUTPUT



NEGATIVE OUTPUT



PROTECTIVE GROUND



WARNING OR CAUTION

DEFINITIONS OF WELDING MODES

NON-SYNERGIC WELDING MODES

- A **Non-synergic** welding mode requires all welding process variables to be set by the operator.

SYNERGIC WELDING MODES

- A **Synergic** welding mode offers the simplicity of single knob control. The machine will select the correct voltage and amperage based on the wire feed speed (WFS) set by the operator.

COMMON WELDING ABBREVIATIONS

WFS

- Wire Feed Speed

CC

- Constant Current

CV

- Constant Voltage

GMAW (MIG)

- Gas Metal Arc Welding

GMAW-P (MIG)

- Gas Metal Arc Welding-(Pulse)

GMAW-PP (MIG)

- Gas Metal Arc Welding-(Pulse-on-Pulse)

GTAW (TIG)

- Gas Tungsten Arc Welding

SMAW (STICK)

- Shielded Metal Arc Welding

FCAW (Innershield or Outershield)

- Flux Core Arc Welding

HF

- High Frequency

CAG

- Carbon Arc Gouging

PRODUCT DESCRIPTION

General Physical Description

The Power Feed 10M Single Wire Feeder is a modular wire feeder, consisting of two components - a **wire drive** and a **control box** - are available assembled as a **bench unit** or as a **boom system**. High speed, highly reliable digital cables connect the components together and to the Power Wave power source.

The Power Feed 10M Single Wire Feeder system has the ability to connect multiple wire feeders to one power source, use the same power source to weld in two different locations (not simultaneously), or load a different electrode on each feeder to eliminate change over time.

The powerful four roll wire drive system sets the industry standard for ease of use. Its patented design allows for tool-less change out of wire guides and drive rolls greatly reducing set up time.

General Functional Description

- The Power Feed 10M Single Wire Feeder is a highly versatile wire feeder with easy to use features that make it easy for the operator to adjust the arc for specific preferences.
- The new MSP4 panel clearly displays key welding information. Use the MSP4 panel to quickly adjust weld settings, arc starting parameters, arc end parameters and set-up variables.
- The Power Feed 10M Single Wire Feeder wire feeder is provided with an infrared red (IR) port. Transferring welding settings from one wire feeder to another is accomplished with a common palm computer.
- When the Power Feed 10M Single Wire Feeder is coupled to a Power Wave welding power source, the result is a welding system with absolutely superior arc performance.

RECOMMENDED PROCESSES

The Power Feed 10M Single Wire Feeder is well suited for all MIG welding processes, giving premium arc performance especially with unusual alloys and out of position work.

- GMAW
- GMAW-Pulse
- GMAW-STT
- FCAW
- SMAW
- GTAW (Touch Start TIG only)
- CAG

POWER FEED 10M SINGLE/DUAL



PROCESS LIMITATIONS

The Power Feed 10M Single Wire Feeder is not suitable for:

- SAW
- GTAW with HF

The MSP4 does not support "Spot" welding.

Not all weld modes or processes described in this manual are available on all Power Wave power sources.

REQUIRED EQUIPMENT

Lincoln's Power Feed 10M Single Wire Feeder is designed for use with the Power Wave family of power sources. These include:

- Power Wave 355
- Power Wave 455
- Power Feed 455/STT
- Power Wave 455M
- Power Wave 455M CE
- Power Wave 455M STT
- Power Wave 455M STT CE
- Power Wave 655

ADDITIONAL REQUIRED EQUIPMENT

- Drive Roll Kits
- Control Cables
- Gun and Cable Assembly
- Weld Wire
- Shielding gas
- Work Cable and Clamp

EQUIPMENT LIMITATIONS

- The Power Feed 10M Single Wire Feeder does not operate with the Power Wave 450.
- The Power Feed 10M Single Wire Feeder does not operate with any analog based power sources (CV-xxx machines, DC-xxx machines, etc.)
- The Memory Panel is required to set procedure limits.
- The Boom model does not support push-pull guns or GTAW welding.
- A push-pull gun and foot amptrol may not be plugged into the Power Feed 10M Single Wire Feeder at the same time.

FRONT PANEL CONTROLS AND CONNECTIONS

FIGURE B.1- CASE FRONT CONTROLS

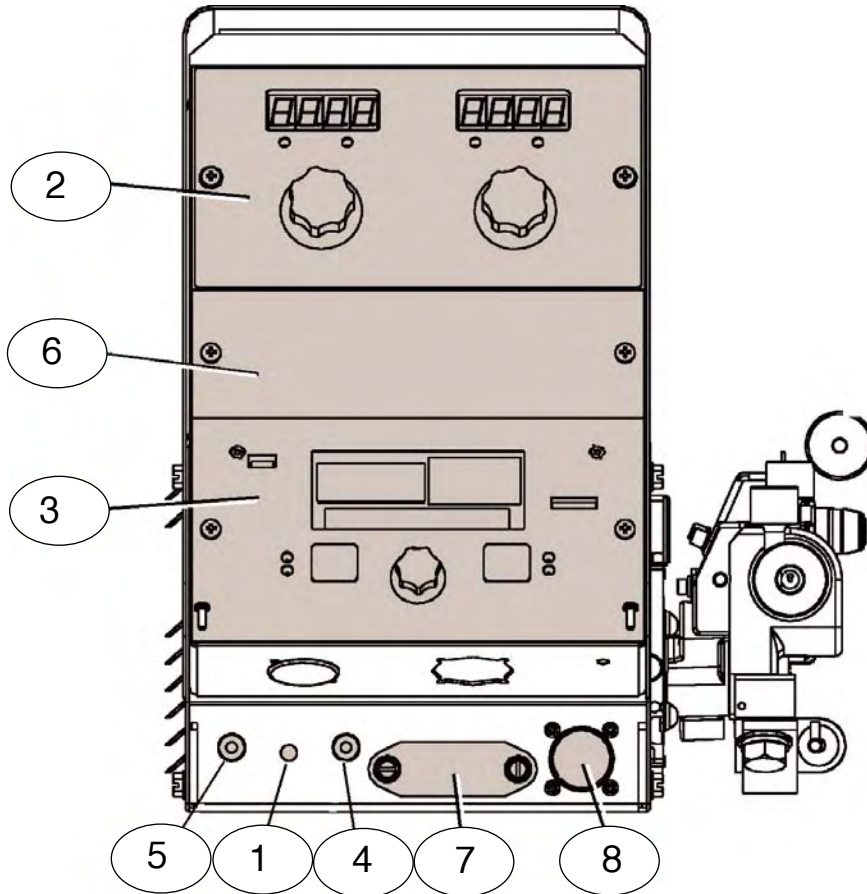

ITEM	DESCRIPTION
1	Status LED indicates system status.
2	Digital Meter Display is a bright LED display of key welding information. Adjusting Parameter Knobs.
3	MSP4 Panel is used to set the weld mode, adjust the arc, change arc start/end parameters and for set-up information.
4	Cold Feed - Gas Purge Switch, press the switch up to feed wire with weld output off. Press the switch down for gas flow with weld output off.
5	2 step - 4 step Switch is used to choose between a 2 step trigger or a 4 step trigger operation.
6	Location for Optional Memory Panel. (Order K2360-1 for the memory panel. See Accessories Section).
7	Cover for Optional Water Cooling Kit, remove when the water cooling kit is installed. See instructions with water cooling kit.
8	Trigger Connector 5-pin amphenol for connecting the MIG gun trigger. See Installation Section for detail.

POWER FEED 10M SINGLE/DUAL

1. STATUS LED

The status LED indicates system status. Normal operation is a steady green light.

Note: During normal power-up, the LED may flash red and/or green as the equipment performs self tests.

LED condition	Definition
Steady green	System okay. The power source and wire feeder are communicating normally.
Blinking green	Occurs during a reset and indicates the power source is identifying each component in the system. This is normal for the first 10 seconds after power-up, or if the system configuration is changed during operation.
Alternating green and red	<p>Non-recoverable system fault. If the power source or wire feeder status LED is flashing any combination of red and green, errors are present in the system. Read the error code before the machine is turned off.</p> <p>Instructions for reading the error code are detailed in the Service Manual. Individual code digits are flashed in red with a long pause between digits. If more than one code is present, the codes will be separated by a green light.</p> <p>To clear the error, turn the power source OFF, and then back ON to reset. See troubleshooting section.</p>
Steady red	Non recoverable hardware fault. Generally indicates a problem with the cables connecting the wire feeder to the power source.
Blinking red	Not applicable.

2. DIGITAL METERS AND OUTPUT ENCODER KNOBS (See Figure B.2)

The primary weld procedure settings are controlled and displayed using digital meters and output encoder knobs located at the top of the Power Feed 10M Single Wire Feeder control panel.

FIGURE B.2

A. WIRE FEED SPEED/AMMETER DISPLAY AND OUTPUT KNOB

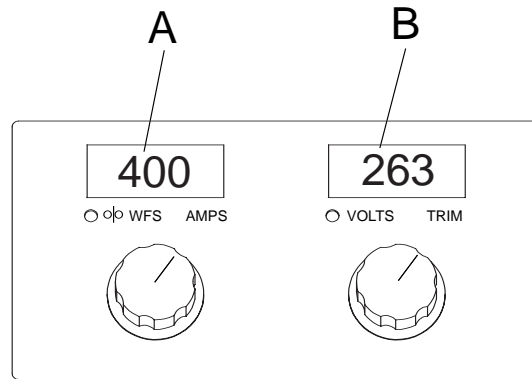

This meter displays either the wire feed speed or current value (Amps) depending upon welding process (Mode) being used and the status of the wire feeder and power source. Written below the display is "WFS" and "Amps". An LED light illuminates which value is being displayed on the meter. The knob below the meter adjusts the value displayed on the meters.

Prior to Welding	Description
CV Welding Processes	Meter displays the preset WFS value.
CC Welding Processes	Meter displays the preset Amps.
During Welding	
An Weld Processes	Meter displays displays the actual average welding Amps.
After Welding	
An Weld Processes	The meter holds the actual current value for 5 seconds. The display blinks to indicate the Power Feed 10M Single Wire Feeder is in the "Hold" period. If the output is adjusted while in the "Hold" period, the Power Feed 10M Single Wire Feeder will revert to the "Prior to welding" display described above.

Note: If the output knob for the WFS/AMPS is adjusted while the Power Feed 10M Single Wire Feeder is in the "Hold" period, the Power Feed 10M Single Wire Feeder will immediately revert to the "Prior to Welding" display.

The default wire feed speed units are inches/minute and can be changed to meters/minute by entering the "Set-up Menu" in this Operation Section. The wire feed speed is calibrated to within ±2%. Refer to the power source manual for calibration specifications of the ammeter.

POWER FEED 10M SINGLE/DUAL



Return to Section TOC

Return to Master TOC

Return to Section TOC

Return to Master TOC

Return to Section TOC

Return to Master TOC

Return to Section TOC

Return to Master TOC

B. VOLTS / TRIM DISPLAY AND OUTPUT KNOB

The voltage/trim meter displays either the voltage or trim value, depending upon the welding process (mode) being used and the status of the wire feeder and power source.

Below the meter are the words "Volts" and "Trim". An LED light illuminates to designate which value is being displayed on the meter. The knob below the meter adjusts the value displayed in the meter. The following tables describe the function of the Volts / Trim display depending upon the status of the wire feeder / power source package and the welding process utilized.

PRIOR TO WELDING

Weld Process	Volts / Trim Display prior to operation
Nonsynergic CV	Displays the preset Voltage value.
Synergic CV	Displays the preset Voltage value.
Synergic CV-Pulse	Displays the preset Trim value from 0.50 to 1.50, with 1.00 as the default. Trim adjusts the arc length for Pulse programs. Lower the trim value to decrease the arc length, and raise the trim value to increase the arc length. A trim value of 1.00 is optimum for most conditions.
Synergic CV-STT	<ul style="list-style-type: none"> Adjusts the background current of the STT waveform. Used to modify the heat input. Linc Net Power Sources: Displays the background current as a value from 0.50 to 1.50, with 1.00 as the default. Lower the trim value to decrease the heat input, and raise the trim value to increase the heat input. A trim value of 1.00 is optimum for most conditions. Arc Link Power Sources: Displays the background current in amps. Lower the background current to decrease the heat input and raise the background current to increase the heat input.
Nonsynergic Power	Displays the preset CP value from 0 to 20. The Power mode is best for thin sheet metal and aluminum applications.

DURING WELDING

Weld Process	Volts / Trim Display
All Processes	Displays Actual Average Arc Voltage

AFTER WELDING

Weld Process	Volt/Trim Display
All Processes	After welding, the meter holds the actual average arc voltage for 5 seconds. During this time, the display flashes to indicate the wire feeder is in the "Hold" period. Output adjustment while in the "Hold" period results in the "prior to operation" characteristics described above.

SYNERGIC CV VOLTAGE DISPLAY

Synergic CV programs feature an ideal voltage best suited for most procedures. Use this voltage as a starting point for the weld procedure and adjust if needed for personal preferences.

The voltage is calibrated to $\pm 2\%$ over a range of 10 to 45 volts.

When the voltage knob is rotated, the display will show an upper or lower bar indicating if the voltage is above or below the ideal voltage.

- Preset voltage above ideal voltage. (upper bar displayed)



- Preset voltage at ideal voltage. (no bar displayed)



- Preset voltage below ideal voltage. (lower bar displayed)



Return to Section TOC
 Return to Master TOC
 Return to Section TOC
 Return to Master TOC
 Return to Section TOC
 Return to Master TOC
 Return to Section TOC
 Return to Master TOC

OVERVIEW:

The MSP4 is the standard mode select panel for the Power Feed 10M Single Wire Feeder wire feeders. The MSP4 is capable of:

- Weld mode selection.
- Arc Control adjustment.
- Weld sequence control (Prewflow Time, Run-in WFS, etc.)

FIGURE B.3

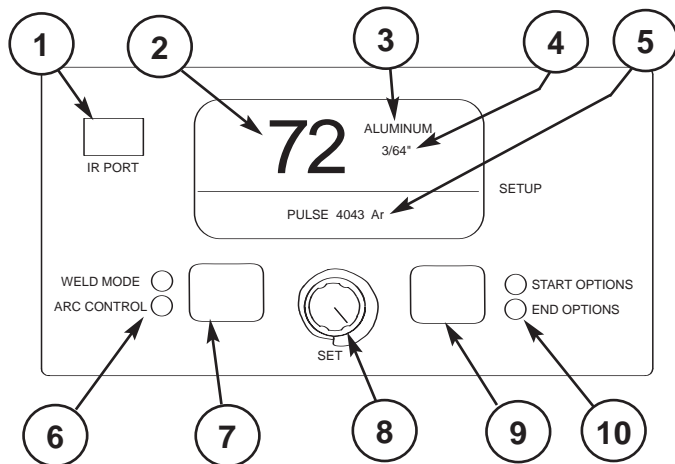
**3. MODE SELECT PANEL 4 (MSP4)**

ITEM	DESCRIPTION
1	IR (Infrared) Port.
2	Weld Mode Number.
3	Weld Wire Type.
4	Wire Size.
5	Weld Mode Description.
6	Status LED Lights-Weld Mode/Arc Control.
7	Selection Pushbutton Weld Mode or Arc Control.
8	"Set" (Adjustment) Dial / Knob
9	Selection Pushbutton Start and End Options.
10	Status LED Lights-Start/End Options.

Through the use of alphanumeric displays, the MSP4 provides standard text messages designed to enhance the user's understanding of the machine's operation as well as provide advanced capabilities. The panel provides:

- Clear identification of the selected weld mode.
- Identification of weld modes not listed on the preprinted weld mode list label.
- Control of up to four wave controls (arc controls.)
- Weld mode specific wave control name display (Peak, Background, Pinch, etc.).
- Unit values are displayed (Amps, in/min, etc.).
- User-friendly machine setup and configuration.

- Limit setting for restricting the operators range of control.
- Lockout to prevent unauthorized changes to machine configuration.

Additionally, the MSP4 includes an infrared (IR) port for wireless communication and configuration using a Palm OS based hand held computer and a simplified control layout.

LAYOUT-CONTROLS (SEE FIGURE B.3)

The MSP4 panel controls (Items 7 and 9) set consist of an encoder knob Item 8 and two push buttons. The encoder is primarily used to change the value of the selected attribute.

The left pushbutton (Item 7) is used to toggle between Weld Mode selection and any active Arc Controls (a.k.a. wave controls). The choices of wave controls varies by weld mode. For example, weld mode 31 has one wave control, "Pinch". Weld mode 110 has three wave controls, "Peak Current", "Background Current" and "Tailout". If the selected weld mode has no wave controls, pressing the left pushbutton will have no affect. If the selected weld mode uses one or more wave controls, pressing the left pushbutton will sequence the selection from weld mode -> wave control 1 (if active) -> wave control 2 (if active) -> wave control 3 (if active) -> wave control 4 (if active) then back to weld mode.

The right pushbutton (Item 9) is used to select attributes that affect the available weld parameters such as preflow time, burnback time, etc. Since most users will require infrequent access to these attributes, they are separate from weld mode selection and wave control adjustment.

LAYOUT-DIGITAL DISPLAY

The MSP4 display consists of a large 4-digit, 7-segment LED display, two 8-character alphanumeric LED displays and one 16-character alphanumeric LED display. The information shown on the various displays depends on the state of the user interface as described below.

When the MSP4 is being used to select a weld mode, the 4-digit display (Item 2) indicates the selected weld mode number. The upper 8-character alphanumeric display (Item 3) indicates the electrode type (steel, aluminum, etc.) The lower 8-character alphanumeric display (Item 4) indicates the electrode size (.035", 1/16", etc.).

POWER FEED 10M SINGLE/DUAL

The 16-character alphanumeric display (Item 5) indicates the process type and other information, the exact content of which depends on the selected weld mode. This additional information may include specific electrode type (e.g. 4043) and/or a description of the recommended gas (e.g. HeArCO₂).

When the MSP4 is being used to change the value of an attribute, the 7-segment displays show the selected attribute's value. The upper 8-character alphanumeric display is typically not used while changing an attribute's value. The lower 8-character alphanumeric display is used to indicate the units of the selected attribute (e.g. seconds, in/min, etc.). The 16-character alphanumeric display is used to display the name of the selected attribute.

The content of the displays while the user interface is being used for advance machine configuration (e.g. limit setting, pass code entering, machine setup, etc.) is described in later sections.

POWER-UP SEQUENCE

When power is first applied to the machine, a lamp test is performed. All discrete LED's are turned on, all 7-segment displays will show a pattern of "8." and all alphanumeric displays will show a hatch pattern where every-other pixel is illuminated. The lamp test will last for two seconds, after which all displays are turned back off. The 16-character alphanumeric display will show "Initializing..." while waiting for the Weld Sequencer to announce bus available. The MSP4 alphanumeric displays will then display the name of the weld table loaded in the power source while the user interface prepares the machine for operation. After all initialization is complete, the MSP4 will display the weld mode information for the mode number that was selected when the machine was last powered down.

CHANGING WELD MODES

To select a weld mode, press the left MSP4 pushbutton until the WELD MODE LED is illuminated. Turn the MSP4 encoder until the desired weld mode number is displayed. As the MSP4 encoder knob is rotated, only the weld mode number is displayed. After 1 second of encoder idle time, the user interface will change to the selected weld mode and the new mode's electrode type, electrode size and process information will appear.

CHANGING ARC WAVE CONTROL

If the selected weld mode uses any of the four available wave controls, users can press the left MSP4 pushbutton until the ARC CONTROL LED is illuminated. The value, name and units (if applicable) of the available wave controls will appear. Note that the name of the control is derived from the weld table and may not necessarily appear as "Wave Control". Repeated pressing of the left MSP4 pushbutton will cycle through all active wave controls and then the weld mode. Turning the MSP4 encoder will change the value of the displayed wave control.

CHANGING WELD SEQUENCE BEHAVIOR

Weld sequencing attributes are grouped into two categories, START OPTIONS and END OPTIONS. START OPTIONS may include Preflow Time, Run-in Wire Feed Speed, and Start Time. END OPTIONS may include Spot Timer, Crater Time, Burnback Time and Postflow Time. The attributes that appear in the START and END OPTIONS are weld mode dependent. For example, if a TIG weld mode is selected, Run-in WFS will not appear since it is not relevant to the selected process. Repeated pressing of the right MSP4 pushbutton will cycle through all relevant START and END OPTIONS. Turning the MSP4 encoder will change the value of the selected option.

When the Start Time attribute is set to a value other than OFF, the START OPTIONS LED will blink synchronous with the WFS and VOLTS/TRIM LED's on the dual-display panel. This blinking is used to indicate that start wire feed speed and voltage/trim can now be set to values different from those used while welding. Similarly, if the Crater Time attribute is set to a value other than OFF, the END OPTIONS LED will blink synchronously with the dual-display LED's, indicating that crater wire feed speed and voltage/trim now can be set to values different from those used while welding.

INFRARED (IR) CONTROL

The MSP4 interface includes an infrared transceiver. This allows wireless machine configuration using a Palm OS based hand held computer. A proprietary Palm OS application, Weld Manager, was developed for this purpose. (Contact Lincoln Electric for more information on this feature.)

LOCKOUT/SECURITY

The MSP4 can be optionally configured to prevent the welder from changing selected user interface controls. By default, all user interface controls can be changed. Weld Manager software (for Palm OS or PC) must be used to lock or unlock user interface controls and to set a pass code

POWER FEED 10M SINGLE/DUAL



LIMIT SETTING

The MSP4 can be optionally configured to limit the operator's range of control of any weld parameter (weld WFS, arc control, etc.). Limits are only available with the Dual Procedure/Memory Panel.

MACHINE SETUP/USER PREFERENCES

The MSP4 can be used to configure and troubleshoot the machine.

ACCESSING THE MACHINE SETUP MENU

To access the Machine Setup menu, press both MSP4 push buttons simultaneously. The MSP4 7-segment display will display the first user preference, "P.0", and the SETUP LED will illuminate.

- Pressing the left MSP4 pushbutton will exit the entire Machine Setup menu while in the P.0 user preference.
- Turning the MSP4 encoder knob will select other available User Preferences.
- To exit the User Preference Menu, either rotate the MSP4 encoder until P.0 is displayed and press the left MSP4 pushbutton or press both MSP4 push buttons simultaneously at any time.

SETUP FEATURES MENU

The Setup Menu gives access to the set-up configuration. Stored in the setup configuration are user parameters that generally need to be set only at installation. The parameters are grouped as follows:

- P.1 through P.99 Unsecured Parameters (always adjustable)
- P.101 through P.199 Diagnostic Parameters (always read only)
- P.501 through P.599 Secured Parameters (accessible only through a p.c. or palm application.)

To access the setup menu, press the right and left buttons of the MSP4 panel simultaneously. Note that the setup menu cannot be accessed if the system is welding, or if there is a fault (The status LED is not solid green).

Change the value of the blinking parameter rotating the SET knob.

To exit the setup menu at any time, press the right and left buttons of the MSP4 panel simultaneously. Alternately, 1 minute of inactivity will also exit the setup menu.

The following list includes all possible parameters in ArcLink equipment. Not all of the parameters listed may appear for your system. Refer to the (TABLE B.1) for active parameters.

TABLE B.1

Unsecured Parameters		* PF= POWER FEED		
PARAMETER	DESCRIPTION	PF*-10M (All Models)	PF*-10A	PF*-15M
P.0	Exit set-up menu	√	√	√
P.1	WFS Units	√	√	√
P.2	Arc Display Mode	√	√	√
P.3	Display Power	√		
P.4	Trigger Memory Recall	√		
P.5	Trigger Procedure Change	√		
P.6	Stall Factor Adjustment	√		
P.7	Gun Offset Adjustment	√		
P.8	TIG Gas Control	√		
P.9	Crater Delay	√		
P.11	Set Timers	√	√	
P.12	Travel Options		√	
P.13	Adjust Arc Force		√	
P.80	Sense From Studs	√		
P.99	Show Test Modes	√	√	
Diagnostic Parameters				
P.100	View Diagnostics	√	√	√
P.101	View Event Logs	√	√	√
P.102	View Fatal Logs	√	√	√
P.103	View Software Version	√	√	√
P.104	View Hardware Version	√	√	√
P.105	View Welding Software	√	√	√
P.106	View Ethernet IP Address	√	√	√
P.107	View Power Source Type	√	√	√

POWER FEED 10M SINGLE/DUAL



Return to Section TOC
Return to Master TOC

- P.0 Press the right button to exit the setup menu.
- P.1 WFS units
Metric = m/min wire feed speed units
English = In/min wire feed speed units (default)
- P.2 Arc Display Mode
Amps = The left display shows Amperage while welding. (default)
WFS = The left display shows Wire Feed Speed while welding.
- P.3 Display Power
When P.3 is set to "Yes", the power will be displayed on the MSP4 while welding. When P.3 is set to "No", power will not be displayed.
- P.4 Trigger Memory Recall
Enable = Selecting memories 2 through 6 with quick trigger pulls is enabled when the optional dual procedure/memory panel is installed. To recall a memory with the gun trigger, quickly pull and release the trigger the number of times that correspond to the memory number. For example, to recall memory 3, quickly pull and release the trigger 3 times. Trigger memory recall can only be performed when the system is not welding.
Disable = Memory selection is performed only by the buttons on the optional dual procedure/memory panel. (default)
- P.5 Procedure Change Method (Three Settings)
In order for any of these procedure change methods to function, the "A-Gun-B" switch must be on the "Gun" position.
1. "**External Switch**" (the default value), the machine will only change the selected procedure when the procedure select digital input changes state.
 2. "**Quick Trigger**" (the optional value 1), the machine will only change the selected procedure when the trigger is released and quickly re-pulled while welding in 2-step. Enable=Allows switching between procedure A and procedure B while welding. The exception is that the procedure select digital input is no longer recognized.
 3. "**Integral Trigger Procedure**" (the optional value 2), the machine will only change the selected procedure when the procedure select digital input changes state.
- Machine operation is similar to the "**External Switch**" selection except that additional logic prevents procedure A from being re-selected when the trigger is quickly and completely released at step 2 of the 4-step weld sequence.

When setup parameter P.5 is set to "Integral ProcTrig",

the machine will always operate in 2-step if a weld is made exclusively in procedure A, regardless of the 2/4 step switch position (this is intended to simplify tack welding when using a dual-schedule gun, such as the Magnum 400 DS, while 4-step trigger is selected).

In order for any of these procedure change methods to function, the "A-Gun-B" switch must be on the "Gun" position.

- P.6 Push Pull Gun, Stall Factor Adjustment
The stall factor controls the stall torque of the push motor when using a push-pull gun. The wire feeder is factory set to not stall unless there is a large resistance to feeding wire. The stall factor can be reduced to stall more easily and possibly prevent bird nesting. However, low stall factors can cause motor stalling while welding which results in the wire burning back to the tip.
If you are experiencing bird nests, check for other feeding problems before adjusting the stall factor.

Default value for the stall factor is 75, with a range of 5 - 100.

To change the stall factor:

- Use the VOLTS/TRIM knob to adjust the stall factor. Increasing the stall factor raises the motor torque and decreasing the stall factor lowers the motor torque. Do not increase the stall factor more than necessary. A high stall factor may increase the occurrence of bird nesting and a low stall factor may cause the wire to burn back to the tip.

- P.7 Push Pull Gun, Gun Offset Adjustment
The push-pull gun offset calibration adjusts the wire feed speed calibration of the pull motor. The procedure should only be performed when other possible corrections do not solve the push-pull feeding problems. A rpm meter is required to perform the pull gun motor offset calibration.

To perform the calibration procedure:

- Release the pressure arm on both the pull and push wire drives.
- Set the wire feed speed to 200 ipm.
- Remove wire from the pull wire drive.
- Hold the rpm meter to the drive roll in the pull gun.
- Pull the trigger on the push-pull gun.
- Measure the rpm of the pull motor. The rpm should be between 115 and 125 rpm. If necessary, decrease the calibration setting to slow the pull motor, or increase the calibration setting to speed up the motor. The calibration range is -30 to +30, with 0 as the default value.

- P.8 TIG Gas Control (Two Settings)
1. "**Valve (manual)**", the internal solenoid will not actuate while TIG welding, gas flow is manually controlled by an external valve.
 2. "**Solenoid (auto)**", the internal gas solenoid will turn on and off automatically while TIG welding as follows:
 - Preflow time will not be accessible from the MSP4.
 - Postflow time will be available in the MSP4 "End Options" and have a range of OFF to 10.0 seconds.
 - The postflow time value is maintained when switching between MIG and TIG modes.
 - When machine output on/off is controlled via the right encoder, gas flow will not start until the tungsten touches, the work piece, gas flow will stop after the postflow time when the arc is broken.
 - When machine output on/off is controlled via an arc start switch or foot Amptrol, gas will begin flowing when the output is turned on and stop flowing after the postflow period after the output is turned off.

- P.9 Crater Delay
- This parameter enables a timer delay for each feed head to bypass the Crater option when short tack welds are desired. If the trigger is released before the timer expires, Crater will be bypassed and the weld will end. If the trigger is released after the timer expires, Crater will function as normal (if Crater function is turned on).

- P.11 Set Timers
- This menu is used to adjust timer values for Upslope, Downslope and Restrike. Press the right button to enter the Set Timer menu. Rotate the knob to select the timer to adjust and then press the right button. Adjust the value of the timer by rotating the knob. Press the left MSP4 button to set the value and exit. Continue to adjust other timers as necessary, and then press the left button to exit the Set Timer menu.

- P.12 Travel Options
- This menu is used to change the travel options for a travel carriage, including starting and ending functions. The right MSP4 button to enter the Travel Options menu and rotate the encoder to select either starting or ending options. Press the right MSP4 button to select the option. Press the left MSP4 button to set the value and exit. Rotate the encoder to select other options, or press the left MSP4 button to exit the menu.

- P.13 Adjust Arc Force
- Use this menu to adjust Arc Force values for Start, Weld and Crater. Press the right MSP4 button to enter the menu and rotate the knob to choose either Start, Weld or Crater. Press the right MSP4 button and then rotate the knob to the desired value. Press the left MSP4 button to set the value and exit.

Continue to adjust Arc Force for other states, and then press the left MSP4 button to exit the menu.

- P.80 Sense From Studs (two settings)
1. "**False**", the voltage sense lead is automatically selected based on the DIP switch configuration and the selected weld mode. This is the default value that is used every time the machine is powered up. Note that setting P.80 to "**False**" does not preclude voltage sensing from the studs if studs sensing is specified by the selected weld mode (for example stick and TIG weld modes will still sense voltage at the studs).

2. "**True**", voltage sensing is forced to "studs" regardless of the DIP switch configuration and selected weld mode. Setting P.80 to "**True**" should only be done for troubleshooting purposes. P.80 will automatically be set back to "**False**" the next time the equipment is powered up or can be manually changed back to "**False**" via the setup menu.

In order to control the welding arc, the power source continually monitors arc current and arc voltage. Arc current is measured internal to the power source. Arc voltage can be measured as follows:

- Voltage internal to the power source ("studs")
- Voltage at the wire feeder ("67" lead)
- Voltage at a user-wired sense lead ("21" lead)

Remote voltage sensing (anything other than "studs") is used to obtain a more accurate voltage measurement since the sense lead is closer to the arc. Remote voltage sensing can involve external wiring and DIP switch configuration, there is a potential for incorrect voltage measurement which can lead to poor arc control or wire burn back.

- P.99 Show Test Modes
- Many weld tables include special modes for testing and servicing the welding system. Set this parameter to YES to show all test modes.

When the power source is turned off, the Show Test Modes parameter automatically reverts back to "NO".

- P.100 View Diagnostics
Diagnostics are only used for servicing the Power Wave system.
Yes = Shows P.101 through P.500 in the SETUP menu.
No = Only P.0 through P.100 are shown in the SETUP menu.
- P.101 Event Logs
Press the right MSP4 button to view the Event Logs. Rotate the encoder to select the object to read and then press the right MSP4 button. Various software information will appear about key system events. Press the left MSP4 button to exit.
- P.102 Fatal Logs
Press the right MSP4 button to view the Fatal Logs. Rotate the encoder to select the module to read and then press the right MSP4 button. Various software information will appear about critical module actions. Press the left MSP4 button to exit.
- P.103 Software Version
Press the right MSP4 button to view the software loaded into each module (p.c. board). Rotate the encoder to select the module to read and then press the right MSP4 button. The panel will display the main software version loaded into the module. Press the left MSP4 button to exit.
- P.104 Hardware Version
Press the right MSP4 button to view the hardware version of each module (p.c. board). Rotate the encoder to select the module to read and then press the right MSP4 button. The panel will display the main hardware version loaded into the module. Press the left MSP4 button to exit.
- P.105 Welding Software
Press the right MSP4 button to view the welding software version inside the power source. Press the left MSP4 button to exit.
- P.106 Ethernet IP Address
Press the right MSP4 button to view the IP address of the Ethernet board. If no Ethernet Board is installed, the display shows "No Enet Found." Press the left MSP4 button to exit.
- P.107 Power Source
Press the right MSP4 button to view the type of power source connected to the control box. Press the left MSP4 button to exit.

4. COLD FEED / GAS PURGE SWITCH

Cold Feed and Gas Purge are combined into a two position momentary toggle switch.

To activate Cold Feeding, hold the switch in the UP position. The wire drive will feed electrode but neither the power source nor the gas solenoid will be energized. Keeping the electrode and gun electrically "cold". Adjust the speed of cold feeding by rotating the WFS knob.

- This feature is useful for threading the electrode through the gun.
- While the "cold feed" circuit is activated, adjust the wire feed speed using the WFS knob.

Hold with toggle switch in the DOWN position to activate Gas Purge and let the shielding gas flow. The gas solenoid valve will energize but neither the power source output nor the drive motor will be turned on. The Gas Purge switch is useful for setting the proper flow rate of shielding gas. Flow meters should always be adjusted while the shielding gas is flowing.

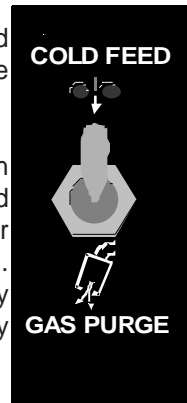

5. 2-STEP / 4-STEP TRIGGER SWITCH

The 2-Step / 4-Step switch has two set positions. Place the switch in the UP position for 2-step Trigger Operation and in the down position for 4-step Trigger Operation.

2 Step Trigger

2 Step trigger operation is the most common. When the gun trigger is pulled, the welding system (power source and wire feeder) cycles through the arc starting sequence and into the main welding parameters. The welding system will continue to weld as long as the gun trigger is activated. Once the trigger is released, the welding system cycles through the arc ending steps.

4-Step Trigger Operation

When the switch is in the 4-Step position the Power Feed 10M Single Wire Feeder provides trigger interlock capability (the operator can release the trigger and the system will continue to weld) and it also allows the operator to control the amount of time spent in the start and crater weld modes.

See Sequence of Operation for more information on the overall interaction trigger switch with the weld sequence.

The 2-Step / 4-Step trigger has no effect when welding with SMAW or CAG procedures.

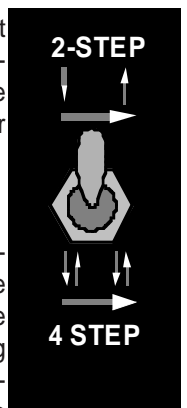

2 STEP TRIGGER OPERATION

(See Figure B.4)

Sometimes it is advantageous to set specific arc start, crater and arc ending parameters for the ideal weld. Many times when welding aluminum crater control is necessary to make a good weld. This is done by setting Start, Crater and Burnback functions to desired values.

SEQUENCE OF OPERATION

Following is the total weld sequence that the Power Feed 10M Single Wire Feeder will execute. If any parameter is inactive or its time is set to zero, the weld procedure immediately shifts to the next parameter in the sequence.

1. PREFLOW: Shielding gas begins to flow immediately when the gun trigger is pulled.
2. STRIKE: After preflow time expires, the power source regulates to the start output and wire is advanced towards the work piece at the Strike WFS. If an arc is not established within 1.5 seconds, the power source output and wire feed speed skips to the weld settings.
3. UPSLOPE: Once the wire touches the work and an arc is established, both the machine output and the wire feed speed ramp to the weld settings throughout the start time. The time period of ramping from the start settings to the weld settings is called UPSLOPE.
4. WELD: After upslope, the power source output and the wire feed speed continue at the weld settings.
5. CRATER: As soon as the trigger is released, the wire feed speed and power source output ramp to the crater settings throughout the crater time. The time period of ramping from the weld settings to the crater settings is called DOWNSLOPE.
6. BURNBACK: After the crater time expires, the wire feed speed is turned OFF and the machine output continues for the burnback time.
7. POSTFLOW: Next, the machine output is turned OFF and shielding gas continues until the post flow timer expires.

FIGURE B.4

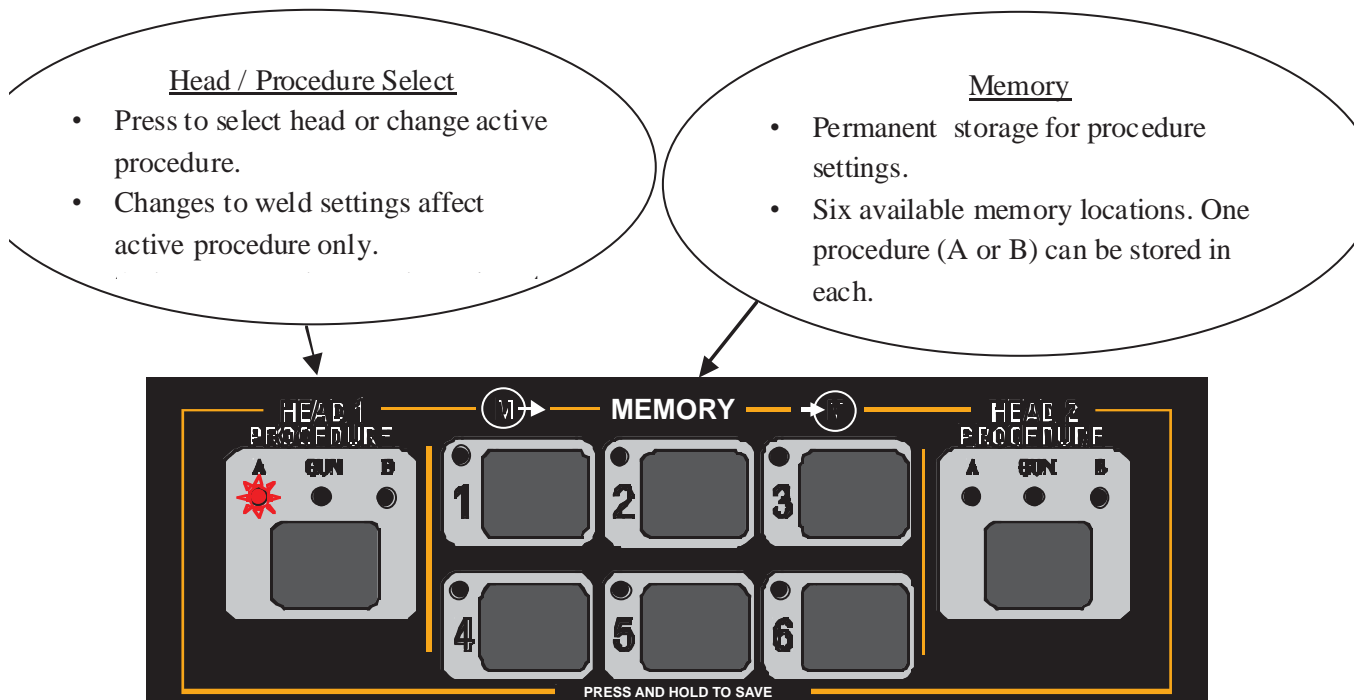

POWER FEED 10M SINGLE/DUAL



4 STEP TRIGGER OPERATION

(See Figure B.5)

The 4 step trigger sequence gives the most flexibility when the Start, Crater and Burnback functions are active. This is a popular choice when welding aluminum because extra heat may be needed during Start and less heat desired during Crater. With 4 step trigger, the welder chooses the amount of time to weld at the Start, Weld and Crater settings by using the gun trigger. Burnback reduces the likelihood of wire to sticking in the weld pool at the end of a weld and also prepares the end of the wire for the next arc start.

SEQUENCE OF OPERATION

Following is the total weld sequence that the Power Feed 10M Single Wire Feeder will execute. If any parameter is inactive or its time is set to zero, the weld procedure immediately shifts to the next parameter in the sequence.

1. PREFLOW: Shielding gas begins to flow immediately when the gun trigger is pulled.
2. STRIKE: After preflow time expires, the power source regulates to the start output and wire is advanced towards the work piece at the Strike WFS. If an arc is not established within 1.5 seconds, the power source output and wire feed speed skips to the weld settings.

3. START: The power source welds at the "Start" WFS and voltage until the trigger is released.
4. UPSLOPE: Once the trigger is released, both the machine output and the wire feed speed ramp up or down to the weld settings throughout the start time. The time period of ramping from the Start settings to the Weld settings is called UPSLOPE.
5. WELD: After Upslope, the power source output and the wire feed speed continue at the Weld settings.
6. DOWNSLOPE: Then as soon as the trigger is pulled, the wire feed speed and power source output ramp to the crater settings during the crater time. The time period of ramping from the weld settings to the crater settings is called DOWNSLOPE.
7. CRATER: After the Downslope time expires, the machine welds at the Crater WFS and voltage settings until either the trigger is released or the Crater time expires.
8. BURNBACK: After the crater time expires, the wire feed speed is turned OFF and the machine output continues for the burnback time.
9. POSTFLOW: Next, the machine output is turned OFF and shielding gas continues to flow until the post flow timer expires.

FIGURE B.5

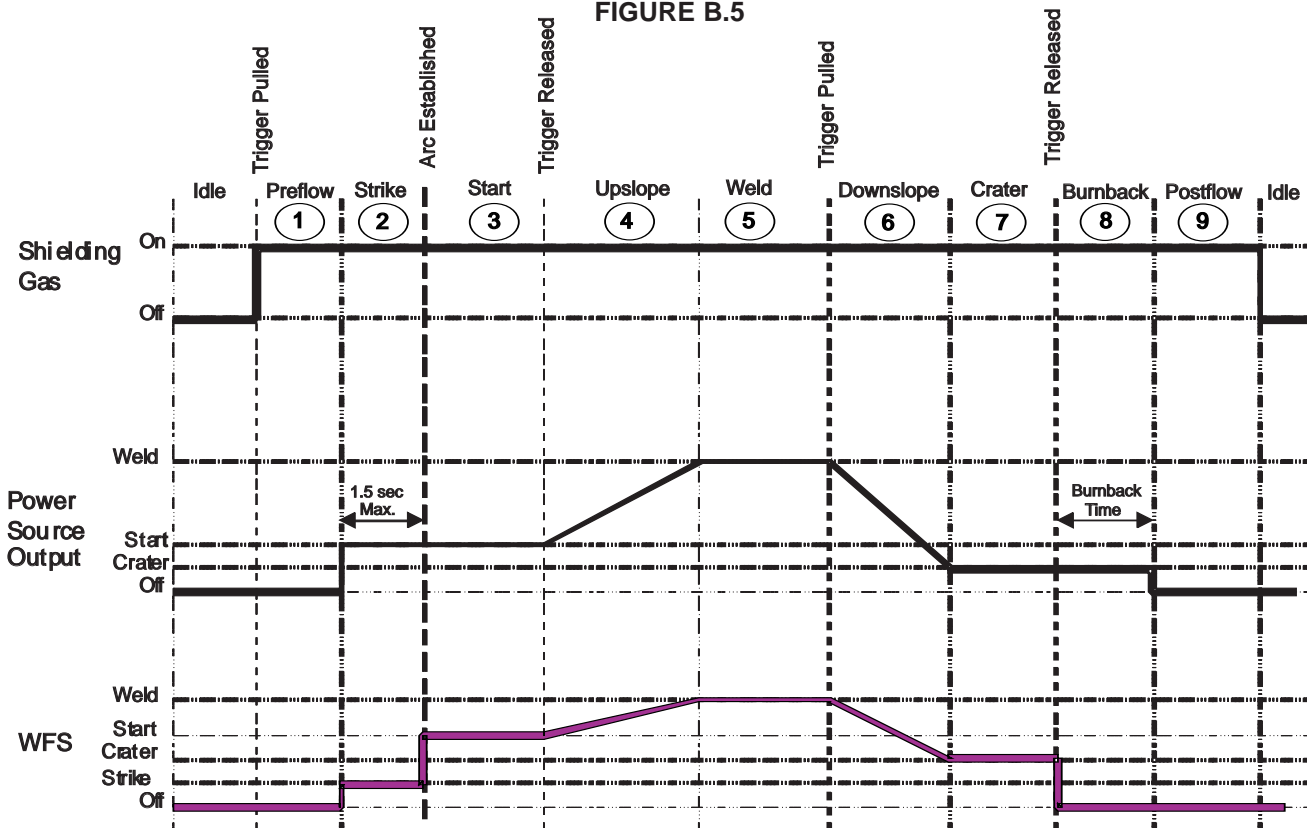

POWER FEED 10M SINGLE/DUAL



Return to Section TOC
Return to Master TOC

PROCESS SETUP AND OPERATION

The Power Feed/Power Wave system delivers world class arc performance for a wide variety of processes. Using the foundation of Waveform Control Technology™, each weld mode is precisely tuned to meet exacting standards for low spatter, weld bead profile and arc shape.

Customized welding software means even the most difficult materials can be welded with the Power Feed/Power Wave system. Copper, Nickel, Silicon Bronze are just a few of the unusual alloys the Power Feed system welds with ease when special software is loaded.

Figure B.6 below shows a list of weld modes common on many Power Wave power sources. This table is found on the inside front panel door of the Power Feed 10M Single Wire Feeder. The specific list of available weld modes depends upon the power source connected to the Power Feed 10M Single Wire Feeder wire feeder.

- CC - Stick Mode
- CC - TIG
- CC - Gouge
- CV - Non Synergic
- CV - Synergic
- CV - Pulse
- CV - Pulse on Pulse
- CV - STT

FIGURE B.6

GENERAL				STEEL					STAINLESS							
GMAW	STD. CV	5		GMAW	CO ₂	0.030	0.035	0.045	0.052	GMAW	Ar (Mix)	0.030	0.035	0.045		
CV	GMAW POWER MODE	40		GMAW	Ar (MIX)	94	11	21	25	GMAW	Ar/He/CO ₂	61	31	41		
FCAW	STD. CV	6		PULSE (CRISP)	Ar (MIX)	95	12	22	26	PULSE	Ar/CO ₂	66	36	46		
STICK	SOFT (7018)	1		PULSE (SOFT)	Ar (MIX)	---	14	19	28	PULSE	Ar/O ₂	62	32	42		
CC	STICK CRISP (6010)	2		STT (NO TAILOUT)	CO ₂ , Ar/CO ₂	109	109	125	125	PULSE	Ar/He/CO ₂	---	34	44		
TIG	TOUCH START	3		STT II	CO ₂ , Ar/CO ₂	110	110	126	126	STT	Ar/He/CO ₂	109	109	125		
GOUGE	---	9								STT II	Ar/He/CO ₂	110	110	126		
ALUMINUM				METAL CORE												
		0.035	3/64	1/16		0.035	3/64	1/16				0.045	0.052	1/16		
4043	GMAW	Ar	148	71	73	5356	GMAW	Ar	151	75	77	PULSE	Ar/CO ₂	81	83	85
	PULSE	Ar	149	72	74		PULSE	Ar	152	76	78	PULSE-ON-PULSE	Ar	101	102	103
	PULSE-ON-PULSE	Ar	98	99	100		PULSE-ON-PULSE	Ar	101	102	103			82	84	86

Non- Synergic Modes

Synergic Modes

[Return to Section TOC](#) | [Return to Master TOC](#)

ALUMINUM SYNERGIC GMAW-P (PULSED MIG) AND GMAW-PP (PULSE ON PULSE) WELDING

The Power Feed 10M Single Wire Feeder and Power Wave welding power source combine to readily produce top quality aluminum welds with excellent appearance, little spatter and good bead shape. Push-pull guns are available for consistent feeding when welding a long distance away from the wire feeder.

Pulse-on-Pulse Welding

The Power Wave system offers both traditional pulse and Pulse-on-Pulse™. Pulse-on-Pulse (GMAW-PP) is an exclusive waveform for aluminum welding. Use it to make welds with a "stacked dime" appearance, similar to GTAW welds.

FIGURE B.7c



The pulsing frequency is adjustable. Changing the frequency modulation (or arc control) of the waveform changes the ripple spacing. Faster travel speeds may be achieved by using higher values of frequency modulation.

FIGURE B.7d

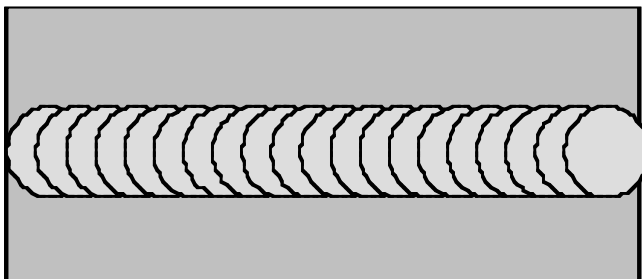

Frequency Modulation = -10
Wide weld and ripple spacing, slow travel speed.

FIGURE B.7e

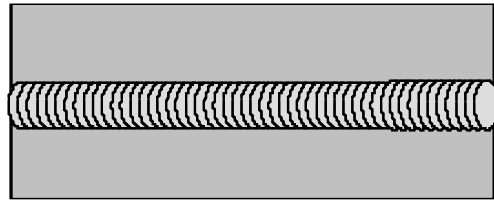

Frequency Modulation = 10
Narrow weld and ripple spacing, fast travel speed.

Return to Section TOC
Return to Section TOC
Return to Section TOC
Return to Section TOC
Return to Master TOC
Return to Master TOC
Return to Master TOC
Return to Master TOC

MACHINE FUNCTIONALITY BY WELD PROCESS

CC-STICK

Use the following tables to review how the machine functions (output controls, arc control, Start options and weld options) for the weld modes listed in the top table.

CC STICK MODES		
Material	PROCESS	MODE
Steel	Stick Soft(7018)	1
Steel	Stick Crisp(6010)	2

OUTPUT CONTROL KNOBS

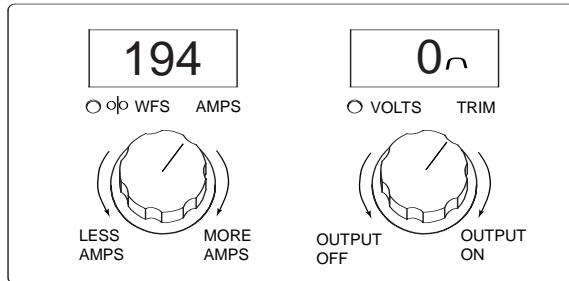

ARC CONTROL

ARC FORCE	DESCRIPTION
(Soft)-10.0 to (Crisp)+10.0	Arc Force adjusts the short circuit current for a soft arc, or for a forceful, driving arc. It helps to prevent sticking and shorting organic coated electrodes, particularly globular transfer types such as stainless and low hydrogen. Arc Force is especially effective for root pass on pipe with stainless electrode and helps to minimize spatter for certain electrodes and procedure as with low hydrogen, etc.

START OPTIONS

START TIME:	FUNCTION
0 to 10 seconds	If no remote control is installed, this control sets the time for the weld output to ramp up or down from a preset Start current to the preset Weld current. Use the WFS/AMP knob to adjust Start current while the Start Options LED is displayed.

END OPTIONS

No arc ending options are active for SMAW (Stick) welding modes.
--

MACHINE FUNCTIONALITY BY WELD PROCESS

CV GMAW/FCAW (NON-SYNERGIC)

Use the following tables to review how the machine functions (output controls, arc control, Start options and weld options) for the weld modes listed in the top table.

CV NON-SYNERGIC MODES		
Material	PROCESS	WELD MODE
Steel	GMAW, CV	5
Steel	GMAW, POWER MODE	40
Steel	FCAW, CV	6

OUTPUT CONTROL KNOBS, WELD MODE 5 & 6

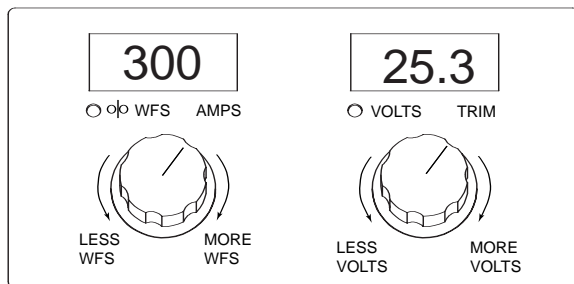

OUTPUT CONTROL KNOBS, WELD MODE 40

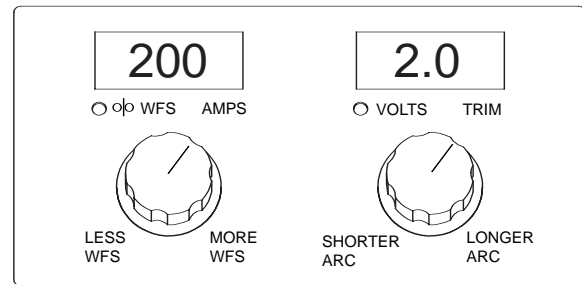

ARC CONTROL

EFFECT / RANGE	DESCRIPTION
(Soft)-10.0 to (Crisp)+10.0	Arc Force adjusts the short circuit current for a soft arc, or for a forceful, digging arc.

START OPTIONS

The start Options available in these Non-Synergic CV weld modes, their adjustment range and function are as follows:

EFFECT / RANGE	DESCRIPTION
Preflow Time 0 - 10 seconds	Adjusts the time the gas flows after the trigger is pulled and prior to feeding.
Run-In WFS: Off, 50 to 150 in/min.	Run-In sets the wire feed speed from the time the trigger is pulled until an arc is established.
Start Procedure 0 - 10 seconds	The Start Procedure controls the WFS and Volts for a specified time at the beginning of the weld. During the start time, the machine will ramp up or down from the Start Procedure to the preset Welding Procedure.

END OPTIONS

EFFECT / RANGE	DESCRIPTION
Postflow Time 0 to 10 seconds	Adjusts the time that shielding gas flows after the welding output turns off.
Crater Procedure (0 TO 10.0 SECONDS)	Crater Procedure controls the WFS and Volts for a specified time at the end of the weld after the trigger is released. During the Crater time, the machine will ramp up or down from the Weld Procedure to the Crater Procedure.
Burnback: 0 to .25 Seconds	The burnback time is the amount of time that the weld output continues after the wire stops feeding. It prevents the wire from sticking in the puddle and prepares the end of the wire for the next arc start.
Spot Timer: 0 to 10 Seconds	Adjusts the time welding will continue even if trigger is still pulled. This option has no effect in 4-Step Trigger Mode.

POWER FEED 10M SINGLE/DUAL



[Return to Section TOC](#) | [Return to Master TOC](#)

MACHINE FUNCTIONALITY BY WELD PROCESS

GMAW (SYNERGIC)

Use the following tables to review how the machine functions (output controls, arc control, Start options and weld options) for the weld modes listed in the top table.

SYNERGIC CV MODES						
MATERIAL	PROCESS	GAS	WIRE SIZE			
			0.030	0.035	0.045	0.052
Steel	GMAW	CO ₂	---	10	20	24
Steel	GMAW	Ar(Mix)	94	11	21	25
Stainless	GMAW	Ar(Mix)	61	31	41	---
Stainless	GMAW	Ar/He/CO ₂	63	33	43	---
Aluminum 4043	TIG	Ar	---	148	71	---
Aluminum 5356	TIG	Ar	---	151	75	---
Metal Core	GMAW	Ar/CO ₂	---	---	---	---

OUTPUT CONTROL KNOBS

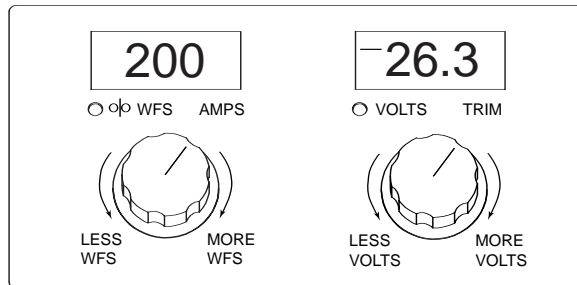

ARC CONTROL

EFFECT / RANGE	DESCRIPTION
PINCH EFFECT (-10.0 to +10.0)	Adjust the short circuit current to create a soft arc, or a forceful, digging arc.

START OPTIONS

The start Options available in these synergic CV weld modes, their adjustment range and function are as follows:

EFFECT / RANGE	DESCRIPTION
Preflow Time 0 - 10 seconds	Adjusts the time the gas flows after the trigger is pulled and prior to feeding.
Run-in WFS: Off, 50 to 150 in/min.	Run-In sets the wire feed speed from the time the trigger is pulled until an arc is established.
Start Procedure	The Start Procedure controls the WFS. Trim at a specified time at the beginning of the weld. During the start time, the machine will ramp up or down from the Start Procedure to the preset Welding Procedure.

END OPTIONS

EFFECT / RANGE	DESCRIPTION
Postflow Time 0 to 10 seconds	Adjusts the time that shielding gas flows after the welding output turns off.
Burnback: 0 to .25 Seconds	The burnback time is the amount of time that the weld output continues after the wire stops feeding. It prevents the wire from sticking in the puddle and prepares the end of the wire for the next arc start.
Crater Procedure	Crater Procedure controls the WFS and volts for a specified time at the end of the weld after the trigger is released. During the Crater time, the machine will ramp up or down from the Weld Procedure to the Crater Procedure.

POWER FEED 10M SINGLE/DUAL



Return to Section TOC
Return to Master TOC

Return to Section TOC
Return to Master TOC

Return to Section TOC
Return to Master TOC

Return to Section TOC
Return to Master TOC

Return to Section TOC
Return to Master TOC

MACHINE FUNCTIONALITY BY WELD PROCESS PULSE AND PULSE-ON-PULSE (SYNERGIC)

Use the following tables to review how the machine functions (output controls, arc control, Start options and weld options) for the weld modes listed in the top table.

PULSE AND PULSE-ON-PULSE MODES			
MATERIAL	PROCESS	GAS	WIRE SIZE
			0.035 3/64 1/16
ALUMINUM 4043	Pulse	Ar	149 72 74
ALUMINUM 4043	Pulse-on-Pulse	Ar	98 99 100
ALUMINUM 5356	Pulse	Ar	152 76 78
ALUMINUM 5356	Pulse-on-Pulse	Ar	101 102 103

OUTPUT CONTROL KNOBS

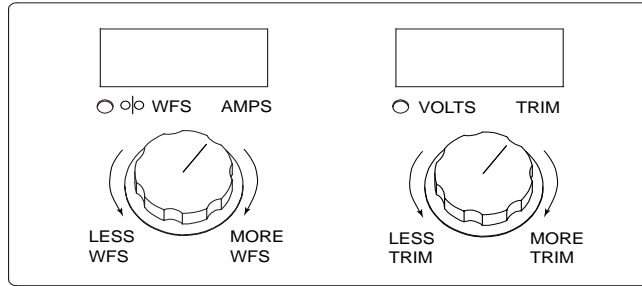

ARC CONTROL

PULSE FREQUENCY:	DESCRIPTION
(Low)-10.0 to (High)+10.0	For Pulse modes, Arc Control changes the pulsing frequency. When the frequency changes, the Power Wave system automatically adjusts the background current to maintain a similar heat input into the weld. Low frequencies give more control over the puddle and high frequencies minimize spatter.

END OPTIONS

EFFECT / RANGE	FUNCTION
Postflow Time: 0 to 10 seconds	Adjusts the time that shielding gas flows after the welding output turns off.
Burnback: 0 to .25 Seconds	The burnback time is the amount of time that the weld output continues after the wire stops feeding. It prevents the wire from sticking in the puddle and prepares the end of the wire for the next arc start.
Crater Procedure	Crater Procedure controls the WFS and volts for a specified time at the end of the weld after the trigger is released. During the Crater time, the machine will ramp up or down from the Weld Procedure to the Crater Procedure.
Spot Timer: 0 to 10 Seconds	Adjusts the time welding will continue even if trigger is still pulled. This option has no effect in 4-Step Trigger Mode.

START OPTIONS

PREFLOW TIME	DESCRIPTION
0 - 10 seconds	Adjusts the time the gas flows after the trigger is pulled and prior to feeding wire.
RUN-IN WFS: Off, 50 to 150 in/min.	Run-in sets the wire feed speed from the time the trigger is pulled until an arc is established.
Start Procedure	The Start Procedure controls the WFS. Trim at a specified time at the beginning of the weld. During the start time, the machine will ramp up or down from the Start Procedure to the preset Welding Procedure.

POWER FEED 10M SINGLE/DUAL



MACHINE FUNCTIONALITY BY WELD PROCESS

STT AND STT II (SYNERGIC)

Use the following tables to review how the machine functions (output controls, arc control, Start options and weld options) for the weld modes listed in the top table.

STT AND STT II MODES			
MATERIAL	PROCESS	GAS	WIRE SIZE
			0.035 0.045 0.052
STEEL STAINLESS	STT	Ar/CO ₂ CO ₂	109 125 125
STEEL STAINLESS	STT II	Ar/CO ₂ CO ₂	110 126 126

OUTPUT CONTROL KNOBS (There is no Voltage control when STT welding.)

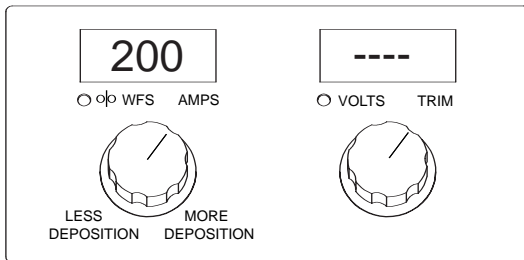

EFFECT / RANGE	DESCRIPTION
PEAK CURRENT	Peak Current acts similar to an arc pinch control. Peak Current sets the arc length and promotes good fusion. Higher peak current levels will cause the arc to broaden momentarily while increasing arc length. If set too high, globular transfer may occur. Setting it too low may cause instability and wire stubbing. Best practice is to adjust for minimum spatter and puddle agitation.
BACKGROUND CURRENT	Background Current controls the overall heat input in the weld. High background currents flatten the weld bead, and low background currents create a taller rounded contour.
TAIL OUT (STT II MODES ONLY)	Tail out provides additional power without the molten droplet becoming too large. Increase as necessary to add heat input without increasing arc length. Often this results in faster travel speeds. Note that as tail out increases, the peak current and/or background current may need to be reduced.

START OPTIONS

PREFLOW TIME	FUNCTION
0 - 10 seconds	Adjusts the time the gas flows after the trigger is pulled and prior to feeding wire.
RUN-IN WFS: Off, 50 to 150 in/min.	Run-in sets the wire feed speed from the time the trigger is pulled until an arc is established.
Start Procedure	The Start Procedure controls the WFS. Trim at a specified time at the beginning of the weld. During the start time, the machine will ramp up or down from the Start Procedure to the preset Welding Procedure.

END OPTIONS

PARAMETER RANGE	FUNCTION
Postflow Time: 0 to 10 seconds	Adjusts the time that shielding gas flows after the welding output turns off.
Crater Procedure	Crater Procedure controls the WFS and volts for a specified time at the end of the weld after the trigger is released. During the Crater time, the machine will ramp up or down from the Weld Procedure to the Crater Procedure.
Burnback: 0 to .25 Seconds	The burnback time is the amount of time that the weld output continues after the wire stops feeding. It prevents the wire from sticking in the puddle and prepares the end of the wire for the next arc start.
Spot Timer: 0 to 10 Seconds	Adjusts the time welding will continue even if trigger is still pulled. This option has no effect in 4-Step Trigger Mode.

POWER FEED 10M SINGLE/DUAL



Return to Section TOC
Return to Master TOC

MACHINE FUNCTIONALITY BY WELD PROCESS

GTAW (Touch Start TIG) Welding

Use the following tables to review how the machine functions (output controls, arc control, Start options and weld options) for the weld modes listed in the top table.

TOUCH START TIG		
Material	PROCESS	MODE
All Metals	Touch Start TIG	3

ARC CONTROL

No Arc Controls are active for Touch Start TIG.

START OPTIONS

START PROCEDURE:

The Start Procedure controls the Amperage at a fixed level for the set amount of time.

END OPTIONS

No Arc ending options are active for Touch Start TIG.

OUTPUT CONTROL KNOBS

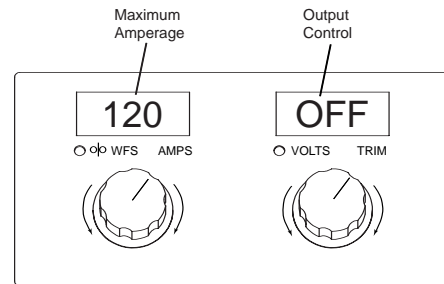

GTAW (TIG) WELDING

The Power Feed / PowerWave system is excellent for Touch Start TIG welding.

The system supports both TIG torches with or without gas control valves. TIG torches with gas control valves connect directly to the gas flow regulator. For TIG torches without gas control valves, connect the output gas hose on the Power Feed 10M Single Wire Feeder.

Touch Start TIG Weld Sequence	No Foot/Hand Amptrol	With Foot/Hand Amptrol
TIG torches without built-in Gas Valves	<ol style="list-style-type: none"> Adjust the arc amperage with the left knob on the display panel. Turn the right knob on the display panel until the Output Control is ON. Gas will start to flow. Touch the tungsten to the work piece. Lift the tungsten to create an arc and weld. Stop welding by turning the Output Control to OFF, or by pulling away the tungsten from the work. Gas flow will continue for a short time and then shut-off. 	<ol style="list-style-type: none"> Adjust the maximum arc amperage with the left knob on the display panel. Touch the tungsten to the work piece. Press the foot pedal or slide the hand amp-trol a slight amount. Gas will start to flow. Lift the tungsten to create an arc. Regulate the arc current with the foot pedal or hand amp-trol. Stop welding by releasing the foot pedal or hand amp-trol, or by pulling the tungsten away from the work. Gas will continue for a short time and then shut-off.
TIG torches with built-in Gas Valves	<ol style="list-style-type: none"> Adjust the arc amperage with the left knob on the display panel. Turn the right knob on the display panel until the Output Control is ON. Open the gas valve on the TIG torch. Touch the tungsten to the work piece. Lift the tungsten to create an arc and weld. Stop welding by turning the Output Control to OFF, or by pulling away the tungsten from the work. Close the gas valve on the TIG torch. 	<ol style="list-style-type: none"> Adjust the maximum arc amperage with the left knob on the display panel. Touch the tungsten to the work piece. Press the foot pedal or slide the hand amp-trol a slight amount. Open the gas valve on the TIG torch. Lift the tungsten to create an arc. Regulate the arc current with the foot pedal or hand amp-trol. Stop welding by releasing the foot pedal or hand amp-trol, or by pulling the tungsten away from the work. Close the gas valve on the TIG torch.

POWER FEED 10M SINGLE/DUAL



Return to Section TOC
 Return to Master TOC
 Return to Section TOC
 Return to Master TOC
 Return to Section TOC
 Return to Master TOC
 Return to Section TOC
 Return to Master TOC

USER MEMORIES

Recall a memory with memory buttons

To recall a user a memory, press one of the six user memory buttons. The memory is recalled when the button is released. Do not hold the button for more than two seconds when recalling a user memory.

Recall a memory with the gun trigger

If desired, memories 2 through 6 can be recalled with the gun trigger. For example, to recall memory 3, quickly pull and release the gun trigger 3 times without welding.

Note: the Power Feed 10M Single Wire Feeder is factory set with this feature disabled. Use the SETUP menu and change P.4 to enable memory recall with the gun trigger.

Save a memory with memory buttons

To save a memory, press and hold the desired memory button for two seconds. When the button is initially pressed, the corresponding LED will illuminate. After two seconds, the LED will turn off. Do not hold the button for more than 5 seconds when saving a user memory.

Note that memories may be locked in the Setup menu to prevent accidental overwrite of the memories. If an attempt is made to save a memory when memory saving is locked, the message "Memory save is Disabled!" will appear briefly in the MSP4 display.

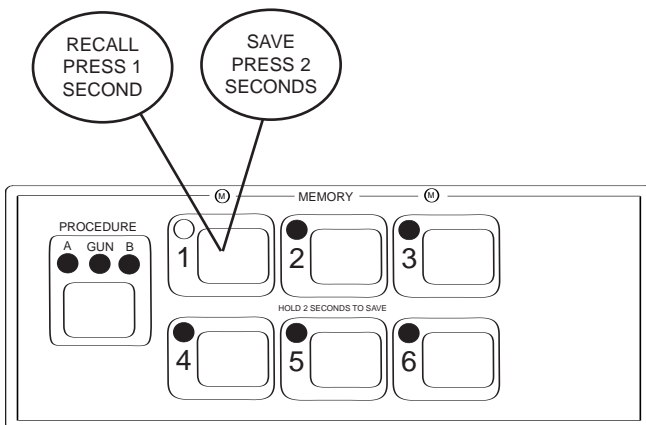

6. OPTIONAL DUAL PROCEDURE/MEMORY PANEL OPERATION

The Dual Procedure/Memory Panel performs three functions:

- Weld procedure selection
- Memory save and recall
- Limits setting

There are two procedure memories (A and B) and six user memories (1-6).

Procedure Memory vs. User Memory

Procedure memory is used while welding. Changes to the weld procedure (WFS, voltage, arc control, etc.) immediately change the contents inside the selected procedure memory. Procedure memory saving is done automatically.

User memories work by copying the weld procedure from one of the six memories into either the A or B procedure. Weld procedures are saved into the memories only when the operator chooses.

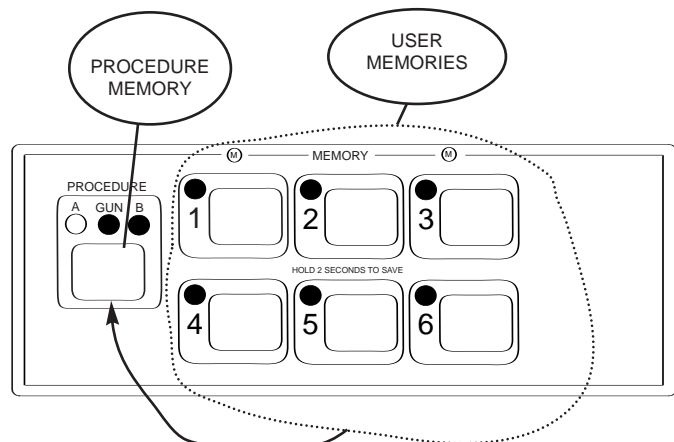

Using Procedure Memories

Procedure memories can be selected by choosing either "A" or "B" procedure directly with the memory panel, or by selecting "GUN" and using a dual procedure gun to select between procedure "A" and "B". When selecting procedures with the gun switch, "A" or "B" will flash to show which procedure is active.

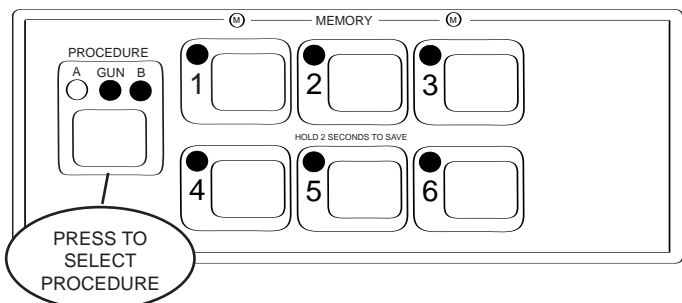

POWER FEED 10M SINGLE/DUAL



Return to Section TOC

Return to Master TOC

Return to Section TOC

Return to Master TOC

Return to Section TOC

Return to Master TOC

Return to Section TOC

Return to Master TOC

LIMIT SETTING

Each user memory can be optionally configured to limit the user's range of control over some user interface settings. By default, user limits are not enabled. To set limits for a selected memory, first select a weld mode and perform a memory save. Next, press and hold the memory button for five seconds. Release the memory button when the memory LED begins to blink rapidly and the Mode Select Panel displays indicate "Set Limits".

If the pass code has been set to a value other than zero, the user will be prompted to enter it. If the pass code is zero, the Mode Select Panel will immediately display the Limit Setup menu and the SETUP LED will illuminate:

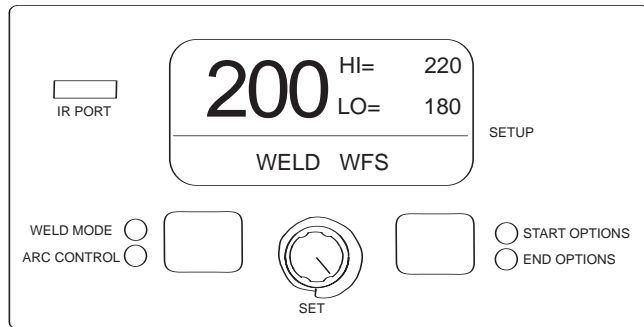

The above example shows a wire mode, constant current weld modes would show "Weld Amps" rather than "Weld WFS".

There are four items displayed on each Limit Setup screen. The long alphanumeric display shows the selected attribute (e.g. Weld WFS,Volts, etc.). The short alphanumeric displays show the selected attribute's high and low user limits. The 7-segment displays show the value that is copied to procedure memory when a memory recall is performed.

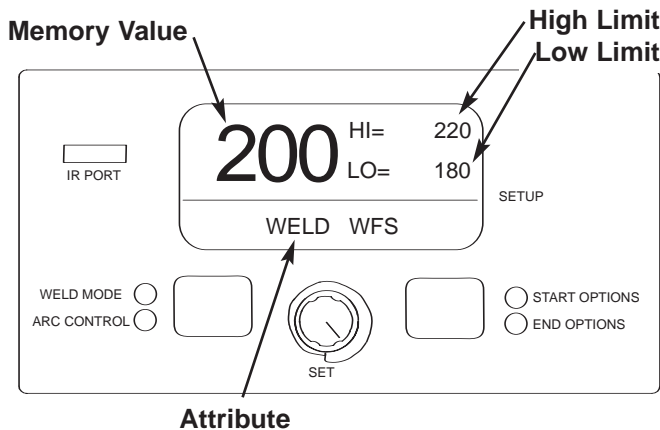

One of these four items will blink to indicate which item will change when the Mode Select Panel Knob is rotated. Initially, the selected item will be the attribute. To select the high limit, press either Mode Select Panel button and the high limit value will begin to blink. Pressing either Mode Select Panel button again will cause the memory value to blink, pressing a third time will cause the low limit to blink.

Weld modes cannot be selected from the Limits Setup menu; the mode must be selected and saved to memory prior to entering the Limits Setup menu.

The memory value, high and low limit values are bound by the limits of the machine. For example, weld mode 49 may allow the wire feed speed to be adjusted between 10 and 200 in/min. These are referred to as "machine limits". Machine limits can vary between power sources and are also weld mode dependent.

The memory value must always be less than or equal to the high limit and greater than or equal to the low limit. The high limit must always be greater than or equal to the low limit and the low limit must always be less than or equal to the high limit. The rules are enforced automatically. If the low limit is increased above the memory value, the memory value will automatically increase.

To lock an attribute to a specific value, set the high and low limits to the desired value. The user will not be able to change it.

After setting limits, press the memory button that is flashing. The Mode Select Panel displays will prompt the user to save or discard the limit changes just made.

By pressing the Mode Select Panel button labeled YES, changes to limits are saved and user limits are automatically enabled. By pressing NO, any changes made to limits are discarded and the limit enable/disable state is not changed.

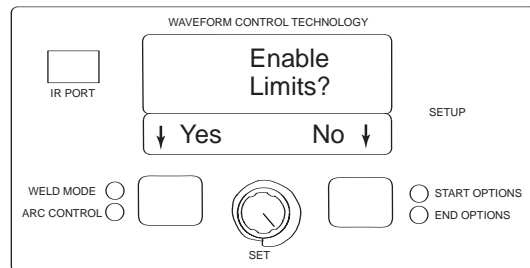

To enable or disable limits that have been established for any memory, press and hold the respective memory button in for more than 10 seconds until the Mode Select Panel displays "Enable Limits?" Pressing "Yes" will use the established limits, while pressing "No" will ignore the established limits. The limits that have been set for any memory location will not be erased if they are disabled.

Return to Section TOC Return to Master TOC

TABLE OF CONTENTS - ACCESSORIES SECTION -

AccessoriesSection C

General Options / AccessoriesC-2/C-4

Return to Master TOC

Return to Master TOC

Return to Master TOC

Return to Master TOC

POWER FEED 10M SINGLE/DUAL



OPTIONAL:

K2339-1	Push-Pull Connection Kit	Includes: Push-Pull Gun Receiver Bushing, Fittings, Modified Gas-Bypass Valve, Valve Removal Tool and Control Cable Extension Assembly.
K2429-1	ArcLink "T" Cable Connector	Includes: 1 "T" connector for connecting 2 Wire Feeders to 1 Power Source.
K2360-1	Dual Procedure/Memory Panel	Includes: 1 memory panel
K1543-xx	ArcLink Cables	Includes: 1 ArcLink cable of length "xx"
K1796-xx	Co-Axial Power Cable	Includes: 1 Coaxial weld cable of length "xx". Ends of the weld cable have lug connections.
K1842-xx	Weld Power Cable	Includes: Lug to Lug, 3/0 Cable of length "xx".
K1500-1	Gun Receiver Bushing (for guns with K466-1 Lincoln gun connectors; Innershield and Subarc guns)	Includes: Gun receiver bushing, set screw and hex key wrench.
K1500-2	Gun Receiver Bushing (for guns with K466-2, K466-10 Lincoln gun connectors; Magnum 200/300/400 guns and compatible with Tweco® #4)	Includes: Gun receiver bushing with hose nipple, set screw and hex key wrench.
K1500-3	Gun Receiver Bushing (for guns with K1637-7 Lincoln gun connectors; Magnum 550 guns and compatible with Tweco® #5)	Includes: Gun receiver bushing with hose nipple, set screw and hex key wrench.

POWER FEED 10M SINGLE/DUAL



K1500-4	Gun Receiver Bushing (for gun with K466-3 Lincoln gun connectors; compatible with Miller® guns.)	Includes: Gun receiver bushing with hose nipple, set screw and hex key wrench.
K1500-5	Gun Receiver Bushing (compatible with Oxo® guns.)	Includes: Gun receiver bushing with hose nipple, 4 guide tubes, set screw and hex key wrench.
K489-7	Gun Receiver Bushing (for Lincoln Fast-Mate guns.)	Includes: Gun receiver bushing with trigger connector.
K466-2	Magnum 200/300/400 to K1500-2 Adapter	Includes: Gun adapter, cotter pin, hex key wrench, wrench.
K613-7	Magnum 550 to K1500-3 Adapter	Includes: Trigger adapter, gun adapter and hex key wrench.
K1546-1	Incoming Bushing, Lincoln Conduit .025- 1/16"	Includes: Incoming bushing and hex key wrench.
K1546-2	Incoming Bushing, Lincoln Conduit 1/16-1/8"	Includes: Incoming bushing and hex key wrench.
K1733-1	Wire Straightener	Includes: Wire Straightener.
K870-1	Foot Amptrol	Includes: Foot Amptrol
K936-1	Hand Amptrol LA-9/-17/LW20	Includes: Hand Amptrol LA-9/-17/LW20
K936-2	Hand Amptrol LA-26/LW-18	Includes: Hand Amptrol LA-26/LW-18

POWER FEED 10M SINGLE/DUAL



K162-1	Spindle Adapter, for Readi-Reels and 2" ID spools up to 60 lb.	Includes: Spindle Assemble with locking clip.
K435	Spindle Adapter, for mounting 14 lb. Innershield Coils on 2" spindles.	Includes: Spindle Adapter made from 2 coil retainers. (Electrode not included.)
K468	Spindle Adapter, for mounting 8" dia. spools on 2" spindles.	Includes: Spindle Adapter.
K363P	Readi-Reel Adapter, for mounting 23-30 lb. reels to 2" spindles.	Includes: Readi-Reel spool adapter. (Spool of electrode not included.)
K438	Readi-Reel Adapter, for mounting 50-60 lb. reels to 2" spindles.	Includes: Readi-Reel spool adapter. (Spool of electrode not included.)
K1504-1	Coil Adapter, for mounting 50-60 lb. coils to 2" spindles.	Includes: 50-60 lb. coil adapter.
K1634-1	Plastic Wire Cover for 30-44 lb. Wire packages.	Includes: Cover, backing plate, wire conduit, incoming bushing for .025 - 1/16" wire, incoming bushing for 1/16" - 1/8" wire, thumb screw, mounting hardware and hex key.
K1634-2	Plastic Wire Cover for up to 60 lb. Wire packages.	
K590-6	Water Connection Kit	Includes: 2 hoses, 4 quick disconnect fittings, hose clamps and mounting hardware.

POWER FEED 10M SINGLE/DUAL



TABLE OF CONTENTS - MAINTENANCE SECTION -

Return to Master TOC

Return to Master TOC

Return to Master TOC

Return to Master TOC

MaintenanceSection D

Routine Maintenance.....D-2

Periodic Maintenance.....D-2

Calibration SpecificationD-2

POWER FEED 10M SINGLE/DUAL



SAFETY PRECAUTIONS

⚠ WARNING



ELECTRIC SHOCK can kill.

- Do not touch electrically live parts such as output terminals or internal wiring.
- When inching with gun trigger, electrode and drive mechanism are "hot" to work and ground and could remain energized several seconds after the gun trigger is released.
- Turn OFF input power at welding power source before installation or changing drive roll and/or guide tubes.
- Welding power source must be connected to system ground per the National Electrical Code or any applicable local codes.
- Only qualified personnel should perform maintenance work.

Observe all additional Safety Guidelines detailed throughout this manual.

ROUTINE MAINTENANCE

- Check weld cables, control cables and gas hoses for cuts.
- Clean and tighten all weld terminals.
- Inspect and clean drive rolls and inner wire guide and replace if worn.

PERIODIC MAINTENANCE

- Blow out or vacuum the inside of the feeder.
- Every six months check the motor brushes. Replace them if they are less than 1/4" long.
- Every year inspect the gearbox and coat the gear teeth with a moly-disulfide filled grease. DO NOT use graphite grease.

CALIBRATION SPECIFICATION

All calibration is factory set on the Power Feed 10M Single Wire Feeder.

To verify the wire feed speed:

- Assemble a .045 (1.2mm) drive roll kit into the Power Feed 10M Single Wire Feeder.
- Load a spool of .045 (1.2mm) electrode and thread the electrode through the wire drive.
- Adjust the wire feed speed to 300 in/min (7.62m/min).
- Press the COLD FEED switch and measure the actual wire feed speed with a calibrated wire feed speed tachometer.
- The measured wire feed speed should be within $\pm 2\%$ of the set value.

1. CONTROL BOX ASSEMBLY
2. WIRE DRIVE ASSEMBLY
3. MOTOR ASSEMBLY
4. GEAR BOX ASSEMBLY
5. SPINDLE ASSEMBLY
6. REEL STAND ASSEMBLY

FIGURE D.1 - MAJOR COMPONENT LOCATION

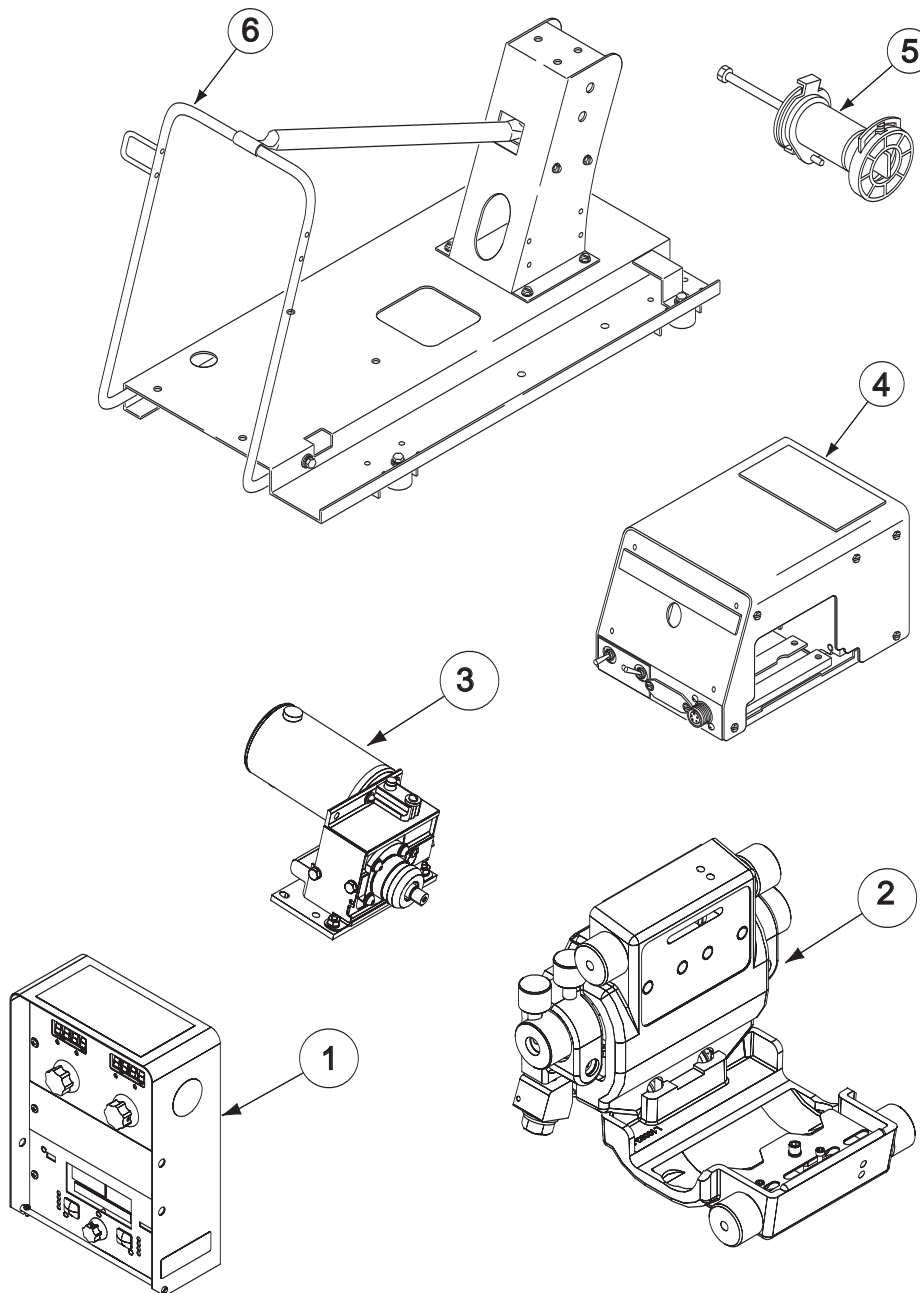

POWER FEED 10M SINGLE/DUAL

Return to Section TOC
Return to Master TOC
Return to Section TOC
Return to Master TOC
Return to Section TOC
Return to Master TOC
Return to Section TOC
Return to Master TOC

POWER FEED 10M SINGLE/DUAL



TABLE OF CONTENTS - INSTALLATION SECTION -

Return to Master TOC

Return to Master TOC

Return to Master TOC

Return to Master TOC

InstallationSection AA

Technical SpecificationsAA-2

Safety PrecautionsAA-3

 Electrode RoutingAA-3

Control CableAA-3

 Control Cable ConnectionsAA-3

 Control Cable Specifications, Available Cable AssembliesAA-3

 Output Cable, Connections and LimitationsAA-4

 Negative Electrode PolarityAA-4

 Electrode Sense Polarity, To Set the Electrode Sense Polarity Switch ...AA-4/AA-5

 Voltage SensingAA-5/AA-6

Wire Drive Gear Ratio (High or Low Speed)AA-6

 Selecting the Proper Gear RatioAA-6

 Changing the Wire Drive RatioAA-7

 Gear Ratio Change ProcedureAA-7

 Gear Ratio RecognitionAA-7

Wire Feed Drive Roll KitsAA-8

Procedure to Install Drive Rolls and Wire GuidesAA-8

Gun and Cable Assemblies with Standard ConnectionAA-8

Gun and Cable Assemblies with Fast-Mate ConnectionAA-8/AA-9

General Gun Connection GuidelinesAA-9

GMAW Sheilding GasAA-9

Wire Spindle PlacementAA-10

Water Connections (For Water Cooled Guns)AA-10

Wire Feed Shut Down Circuit (Optional)AA-10

Examples of Connecting an Arlink Power Wave SystemAA-10/AA-11



TECHNICAL SPECIFICATIONS – Power Feed 10M Dual Wire Feeder

WIRE DRIVE OR WIRE DRIVE SECTION OF FEEDER							
SPEC.#	TYPE	LOW SPEED RATIO			HIGH SPEED RATIO		
		Speed	Wire Size		Speed	Wire Size	
	Solid		Cored	Solid		Cored	
K2234-1 K2316-1	Bench Model Boom Model	50-800 IPM (1.27-20.3 m/m)	.025 - 3/32 in. (0.6 - 2.4 mm)	.035 - .125 in. (0.9 - 3.2 mm)	75 - 1200 IPM (2.0 - 30 m/m)	.025 - 1/16 in. (0.6 - 1.6 mm)	.035 - 5/64 in. (0.9 - 2.0 mm)

CONTROL BOX, WIRE DRIVE AND COMPLETE UNITS								
SPEC.#	TYPE	INPUT POWER	PHYSICAL SIZE			TEMPERATURE RATING		
			Dimensions			Weight	Operating	Storage
			Height	Width	Depth			
K2234-1 Bench Model Feeder	Wire Drive & Reel Stand	40VDC	19.9" (506 mm)	19.9" (506 mm)	30.6" (777 mm)	90 Lbs (40.8 Kg.)	14°F to 140°F (-10°C to 40°C)	-40°F to 185°F (-40°C to 40°C)
K2316-1 Boom Model Feeder	Control Box only		Dimensions Δ			Weight		
			Height	Width	Depth			
			13.0" (330 mm)	8.5" (215 mm)	4.0" (105 mm)	10.1Lbs (4.5 Kg.)		
K2316-1 Boom Model Feeder	Wire Drive only		Dimensions Δ			Weight		
			Height	Width	Depth			
			9.0" (228 mm)	19.0" (483 mm)	15.5" (394 mm)	40 Lbs (18.1Kg.)		

WELDING CAPACITY RATING	
Amp Rating	Duty Cycle
600 A	60%
500 A	100%

Δ Dimensions do not include wire reel.



[Return to Section TOC](#) | [Return to Master TOC](#)

SAFETY PRECAUTION



ELECTRIC SHOCK can kill.

- Only qualified personnel should perform this installation.
- Turn off the input power to the power source at the disconnect switch or fuse box before working on this equipment. Turn off the input power to any other equipment connected to the welding system at the disconnect switch or fuse box before working on this equipment.

- Do not touch electrically hot parts.
- Always connect the Power Wave grounding lug (located inside the reconnect input access door) to a proper safety (Earth) ground.

ELECTRODE ROUTING

The electrode supply may be either from reels, Readi-Reels, spools, or bulk packaged drums or reels. Observe the following precautions:

- The electrode must be routed to the wire drive unit so that the bends in the wire are at a minimum, and also that the force required to pull the wire from the reel into the wire drive unit is kept at a minimum.
- The electrode is "hot" when the gun trigger is pressed and must be insulated from the boom and structure.
- If more than one wire feed unit shares the same boom and are not sharing the some power source output stud, their wire and reels must be insulated from each other as well as insulated from their mounting structure.

CONTROL CABLE

CONTROL CABLE CONNECTIONS

- All system control cables are the same.
- All control cables can be connected end to end to extend their length.
- All system equipment must be connected to a control cable.

NOTE: The maximum cable length between Power Source and Wire Feeder is 100'(30.5m).

Typical Bench Feeder Connection:

Control cable is connected from the Power Wave 455 output receptacle to the input receptacle on the back of the Wire Drive.

CONTROL CABLE SPECIFICATIONS

It is recommended that only genuine Lincoln control cables be used at all times. Lincoln cables are specifically designed for the communication and power needs of the Power Wave 455 / Power Feed system. The use of non-standard cables, especially in lengths greater than 25 feet(7.6m), can lead to communication problems (system shutdowns), poor motor acceleration (poor arc starting) and low wire driving force (wire feeding problems).

Lincoln control cables are copper 5 conductor cable in a SO-type rubber jacket. There is one 20 gauge twisted pair for network communications. This pair has an impedance of approximately 120 ohms and a propagation delay per foot of less than 2.1 nanoseconds. There are two 12 gauge conductors that are used to supply the 40 VDC to the network. The fifth wire is 18 gauge and is used as an electrode sense lead.

AVAILABLE CABLE ASSEMBLIES

K1543 Control cable only. Available in lengths of 8'(2.4m), 16'(4.9m), 25'(7.6m), 50'(15.2m) and 100'(30.5m).

OUTPUT CABLES, CONNECTIONS AND LIMITATIONS

Connect a work lead of sufficient size and length (Per Table AA.1) between the proper output terminal on the power source and the work. Be sure the connection to the work makes tight metal-to-metal electrical contact. To avoid interference problems with other equipment and to achieve the best possible operation, route all cables directly to the work or wire feeder. Avoid excessive lengths and do not coil excess cable.

Minimum work and electrode cables sizes are as follows:

TABLE AA.1

(Current (60% Duty Cycle))	MINIMUM COPPER WORK CABLE SIZE AWG
	Up To-100 Ft. Length (30 m)
400 Amps	2/0 (67 mm ²)
500 Amps	3/0 (85 mm ²)
600 Amps	3/0 (85 mm ²)

NOTE: K1796 coaxial welding cable is recommended to reduce the cable inductance in long distance Pulse applications up to 300 amps.

CAUTION

When using an inverter type power source like the PowerWaves, use the largest welding (electrode and work) cables that are practical. At least 2/0 copper wire - even if the average output current would not normally require it. When pulsing, the pulse current can reach very high levels. Voltage drops can become excessive, leading to poor welding characteristics, if undersized welding cables are used.

Output connections on some Power Waves are made via 1/2-13 threaded output studs located beneath the spring loaded output cover at the bottom of the case front.

Most welding applications run with the electrode being positive (+). For those applications, connect the electrode cable between the wire feeder and the positive (+) output stud on the power source (located beneath the spring loaded output cover near the bottom of the case front). Connect the other end of the electrode cable to the wire drive feed plate. The electrode cable lug must be against the feed plate. Be sure the connection to the feed plate makes tight metal-to-metal electrical contact. The electrode cable should be sized according to the specifications given in the work cable connections section. Connect a work lead from the negative (-) power source output stud to the work piece. The work piece connection must be firm and secure, especially if pulse welding is planned.

For additional Safety information regarding the electrode and work cable set-up, See the standard "SAFETY INFORMATION" located in the front of the Instruction Manuals.

CAUTION

Excessive voltage drops caused by poor work piece connections often result in unsatisfactory welding performance.

NEGATIVE ELECTRODE POLARITY

When negative electrode polarity is required, such as in some Innershield applications, reverse the output connections at the power source (electrode cable to the negative (-) stud, and work cable to the positive (+) stud).

ELECTRODE SENSE POLARITY

This options allows for the setting of negative polarity sensing when a negative polarity welding process is performed.

When negative electrode polarity is required, such as in some Innershield applications, reverse the output connections at the power source (electrode cable to the negative (-) stud, and work cable to the positive (+) stud).

When operating with electrode polarity negative the Wire Feeder must be set to recognize this option.

To Set the Electrode Sense Polarity Switch

WARNING



ELECTRIC SHOCK can kill.

- Turn the input power OFF at the disconnect switch before working on this equipment.
- Do not touch electrically hot parts.

CAUTION

When changing the electrode polarity, the weld cables must be changed at the power source studs and the DIP switch inside the Power Feed 10M Dual must be properly set. Operation with the DIP switch in the wrong position will cause erratic arc performance.

The Power Feed 10M Dual Wire Feeder is factory set for Electrode Positive welding.

Most welding procedures use Electrode Positive welding. Some Innershield procedures may use Electrode Negative welding. For most applications, the Power Feed 10M Dual Wire Feeder will have both sides of the Wire Drive set to the same polarity. To weld with opposite polarities, each head would have to be welding on isolated work pieces and the weld cable attaching the two feed heads would have to be removed.

To change the DIP switch inside the Power Feed 10M Dual Wire Feeder for electrode polarity:

1. Turn off power at the welding power source.
2. Remove the rear access panel on the wire drive.
3. Locate DIP switches on BOTH Wire Drive Boards.
4. Set DIP switch #7 on BOTH Wire Drive Boards to the desired polarity.

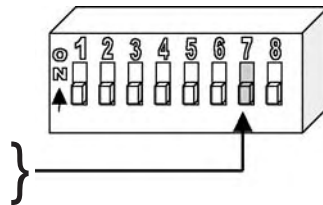

DIP Switch #7 Position
Polarity

ON (Up) - (negative) polarity
OFF (Down) + (positive) polarity

5. Assemble the rear access panel to the wire drive.
6. Restore power.

VOLTAGE SENSING

The best arc performance occurs when the PowerWaves have accurate data about the arc conditions. Depending upon the process, inductance within the electrode and work lead cables can influence the voltage apparent at the studs of the welder. Voltage sense leads improve the accuracy of the arc conditions and can have a dramatic effect on performance. Sense Lead Kits (K940-xx) are available for this purpose.



CAUTION

If the voltage sensing is enabled but the sense leads are missing, improperly connected, or if the electrode polarity switch is improperly configured, extremely high welding outputs may occur.

The ELECTRODE sense lead (67) is built into the control cable, and is automatically enabled for all semi-automatic processes. The WORK sense lead (21) connects to the Power Wave at the four pin connector located underneath the output stud cover. By default the WORK voltage is monitored at the output stud in the Power Wave 455. For more information on the WORK sense lead (21), see "**Work Voltage Sensing**" in the following paragraph.

Enable the voltage sense leads as follows:

TABLE AA.2

Process	Electrode Voltage Sensing 67 lead *	Work Voltage Sensing 21 lead
GMAW	67 lead required	21 lead optional
GMAW-P	67 lead required	21 lead optional
FCAW	67 lead required	21 lead optional
GTAW	Voltage sense at studs	Voltage sense at studs
GMAW	Voltage sense at studs	Voltage sense at studs
SAW	67 lead required	21 lead optional
CAC-C	Voltage sense at studs	Voltage sense at studs

* The electrode voltage 67 sense lead is integral to the control cable to the wire feeder.

Work Voltage Sensing

The standard Power Wave 455's default to the work stud (work sense lead disabled)

For processes requiring work voltage sensing, connect the (21) work voltage sense lead (K940) from the Power Wave work sense lead receptacle to the work piece. Attach the sense lead to the work piece as close to the weld as practical, but not in the return current path. Enable the work voltage sensing in the Power Wave as follows:

⚠ WARNING



- Do not touch electrically live parts or electrodes with your skin or wet clothing.
- Insulate yourself from the work and ground.

- Always wear dry insulating gloves.

1. Turn off power to the power source at the disconnect switch.
2. Remove the front cover from the power source.
3. The control board is on the left side of the power source. Locate the 8-position DIP switch and look for switch 8 of the DIP switch.
4. Using a pencil or other small object, slide the switch right to the OFF position if the work sense lead is NOT connected. Conversely, slide the switch left to the ON position if the work sense lead is present.
5. Replace the cover and screws. The PC board will "read" the switch at power up, and configure the work voltage sense lead appropriately.

Electrode Voltage Sensing

Enabling or disabling electrode voltage sensing is automatically configured through software. The 67 electrode sense lead is internal to the cable to the wire feeder and always connected when a wire feeder is present.

⚠ CAUTION

Important: The electrode polarity must be configured at the feed head for all semi-automatic processes. Failure to do so may result in extremely high welding outputs.

WIRE DRIVE GEAR RATIO (HIGH OR LOW SPEED)

The speed range capability and drive torque of the Power Feed wire drives can be easily and quickly changed by changing the external drive gear. The Power Feed Wire Feeders are shipped with both high speed and a low speed gears. As shipped from the factory, the low speed (high torque) gear is installed on the feeder. If this is the desired gear ratio, no changes need be made.

If a change in gear ratio is desired, the systems needs to be made aware of which gear has been installed on the Wire Drive, low or high speed. This is accomplished through the selection of a dip switch on the wire drive PCB.

SELECTING THE PROPER GEAR RATIO

See Technical Specifications at the front of the Installation Section for feed speed and wire size capabilities with high and low speed gear ratios. To determine whether you should be using the high or low speed ratio use the following guidelines:

- If you need to operate at wire feed speeds above 800 IPM (20 m/m), you will need to install the high speed gear (large 30 tooth, 1.6 inch diameter gear).
- If you do not need to run at wire feed speeds in excess of 800 IPM (20 m/m), you should use the low speed gear (small, 20 tooth, 1.1 inch diameter gear). Using the low speed ratio will provide the maximum available wire driving force.

Note: If you are feeding only small diameter wires you may, at your option, install the high speed ratio.

CHANGING THE WIRE DRIVE GEAR RATIO

Changing the ratio requires a gear and a dip switch setting change. The Power Feed Wire Feeders are shipped with both high speed and a low speed gears. As shipped from the factory, the low speed (high torque) gear is installed on the feeder. For identification purposes, the low speed (high torque) gear has 20 teeth and is 1.1 inches in diameter. The high speed gear has 30 teeth and is 1.6 inches in diameter.

⚠ WARNING

Power down the Power Feed 10M Dual Wire Feeder by turning off its companion Power Wave power source. For maximum safety, disconnect the control cable from the Power Feed 10M Dual Wire Feeder.

GEAR RATIO CHANGE PROCEDURE:

1. Pull open the Wire Drive Door.
2. Remove the Phillips head screw retaining the pinion gear to be changed and remove the gear. If the gear is not easily accessible or difficult to remove, remove the feed plate from the gearbox. To remove feed plate:
 - a. Loosen the clamping collar screw using a 3/16" Allen wrench. The clamping collar screw is accessed from the bottom of the feed plate. It is the screw which is perpendicular to the feeding direction.
 - b. Loosen the retaining screw, which is also accessed from bottom of feeder, using a 3/16" Allen wrench. Continue to loosen the screw until the feed plate can be easily pulled off of the wire feeder.
3. Loosen, but do not remove, the screw on the lower right face of the feed plate with a 3/16" Allen wrench.
4. Remove the screw on the left face of the feed plate. If changing from high speed (larger gear) to low speed (smaller gear), line the lower hole on the left face of the feed plate with the threads on the clamping collar. Line the upper hole with the threads to install larger gear for high speed feeder. If feed plate does not rotate to allow holes to line up, further loosen the screw on right face of feed plate.

5. Remove the small gear from the output shaft. Lightly cover the output shaft with engine oil or equivalent. Install gear onto output shaft and secure with flat washer, lock washer, and Phillips head screw which were previously removed.
6. Tighten the screw on lower right face of feed plate.
7. Re-attach feed plate to wire feeder if removed in Step 2.
8. Feed plate will be rotated out-of-position due to the gear change. Adjust the angle of the feed plate per the instructions above.
9. Set the wire drive gear ratio switch on Wire Drive PC board as follows:

GEAR RATIO RECOGNITION:

1. Remove the rear access door from the wire feeder case.
2. Locate the dip switch bank on the P.C. board (**refer to table AA.3**)
3. Locate dip switch # 8 and move it to the appropriate gear ratio setting as described below:

FIGURE AA.2

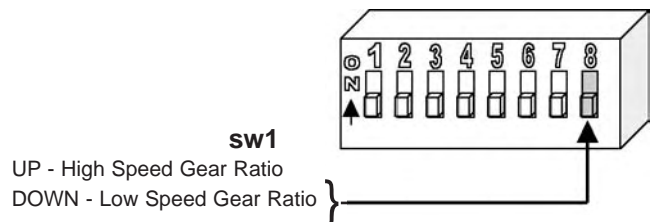

4. Replace the rear access door of the wire feeder case.

Note: The system recognizes dip switch settings only during system power-up.

TABLE AA.3

	PF-10M Feeder location (Facing rear of unit)	PF-10M P.C. board location (Facing rear of unit)
Feeder 1	Right	On inside divider panel
Feeder 2	Left	On rear access door

WIRE FEED DRIVE ROLL KITS

NOTE: The maximum rated solid and cored wire sizes and selected drive ratios are shown on the SPECIFICATIONS in the front of this section.

The electrode sizes that can be fed with each roll and guide tube are stenciled on each part. Check the kit for proper components. Kit specifications can be found in the ACCESSORIES section.

PROCEDURE TO INSTALL DRIVE ROLLS AND WIRE GUIDES

⚠ WARNING



ELECTRIC SHOCK can kill.

- Do not touch electrically live parts such as output terminals or internal wiring.
- When feeding without Power Feed 10 Dual “Cold Feed” feature, electrode and drive mechanism are “hot” to work and ground and could remain energized several seconds after the gun trigger is released.
- Turn OFF input power at welding power source before installation or changing drive roll and/or guide tubes.
- Welding power source must be connected to system ground per the National Electrical Code or any applicable local codes.
- Only qualified personnel should perform this installation.

Drive Roll Kit Installation (KP1505-[J])

- Turn OFF Welding Power Source.
- Pull open Pressure Door to expose rolls and wire guides.
- Remove Outer Wire Guide by turning knurled thumb screws counter-clock-wise to unscrew them from Feedplate.

Observe all additional Safety Guidelines detailed throughout this manual.

- Remove drive rolls, if any are installed, by pulling straight off shaft. Remove inner guide.

- Insert inner Wire Guide, groove side out, over the two locating pins in the feedplate.
- Install each drive roll by pushing over shaft until it butts up against locating shoulder on the drive roll shaft. (Do Not exceed maximum wire size rating of the wire drive).
- Install Outer Wire Guide by sliding over locating pins and tightening in place.
- Engage upper drive rolls if they are in the “open” position and close Pressure Door.

TO SET DRIVE ROLL PRESSURE, see “Drive Roll Pressure Setting” in OPERATION.

GUN AND CABLE ASSEMBLIES WITH STANDARD CONNECTION

The Power Feed 10 Dual Wire Feeder is equipped with a factory installed K1500-2 gun connection Kit. This kit is for guns having a Tweco™ #2-#4 connector. The Power Feed 10 Dual Wire Feeder has been designed to make connecting a variety of guns easy and inexpensive with the K1500 series of gun connection kits. Gun trigger and dual procedure lead connections connect to the single 5 pin receptacle on the front of the feed head box. See “Gun Adapters” in ACCESSORIES section.

GUN AND CABLE ASSEMBLIES WITH FAST-MATE™ CONNECTION (including the Magnum 450 Water Cooled gun)

A K489-7 adapter will install directly into the wire drive feedplate, to provide for use of guns with Fast-Mate™ or European style gun connections. This K489-7 will handle both standard Fast-Mate™ and Dual Schedule Fast-Mate™ guns.

Another way to connect a gun with a Fast-Mate™ or European style gun connector to the Power Feed 10 Dual Wire Feeder, is to use the K489-2 Fast-Mate™ adapter kit. Installation of this adapter also requires a K1500-1 gun connector. See “Gun Adapters” in ACCESSORIES section.

Magnum 200 / 300 / 400 Guns

The easiest and least expensive way to use Magnum 200/300/400 guns with the Power Feed 10 Dual Wire Feeder is to order them with the K466-10 connector kit, or to buy a completely assembled Magnum gun having the K466-10 connector (such as the K497-21 dedicated Magnum 400).

Magnum 550 Guns

The easiest and least expensive way to use the Magnum 550 guns with Power Feed 10 Dual wire feeders is to order the gun with the K613-7 connector kit, and install a K1500-3 gun connection kit to the wire feeder.

Lincoln Innershield and Sub Arc Guns

All of these guns can be connected to the Power Feed 10 Dual Wire Feeder by using the K1500-1 Adapter Kit.

Lincoln Fume Extraction Guns

The K556 (250XA) and K566 (400XA) guns require that a K489-2 Fast-Mate™ adapter kit be installed. Installation of this adapter also requires a K1500-1 gun connector kit.

The K206, K289, and K309 require only the installation of a K1500-1 connector in the Power Feed wire feeder.

Non-Lincoln Guns

Most competitive guns can be connected to the Power Feed 10 Dual Wire Feeder by using one of the K1500 series adapter kits, See "Gun Adapters" in ACCESSORIES section.

GENERAL GUN CONNECTION GUIDELINES

The instructions supplied with the gun and K1500 series gun adapter should be followed when installing and configuring a gun. What follows are some general guidelines that are not intended to cover all guns.

- Check that the drive rolls and guide tubes are proper for the electrode size and type being used. If not, change them.
- Lay the cable out straight. Insert the connector on the welding conductor cable into the brass conductor block on the front of the wire drive head. Make sure it is all the way in and tighten the hand clamp. Keep this connection clean and bright. Connect the trigger control cable polarized plug into the mating 5 cavity receptacle on the front of the wire drive unit.

Note: for Fast-Mate and European connector style guns, connect gun to gun connector making sure all pins and gas tube line up with appropriate holes in connector. Tighten gun by turning large nut on gun clockwise.

- For GMA Gun Cables with separate gas fittings, connect the 3/16" I.D. gas hose from the wire drive unit to the gun cable barbed fitting.
- For water cooled guns see WATER CONNECTIONS in this section.

GMAW SHIELDING GAS

WARNING

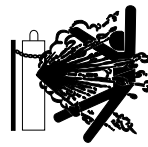

CYLINDER may explode if damaged.

- Keep cylinder upright and chained to support.
- Keep cylinder away from areas where it may be damaged.
- Never lift welder with cylinder attached.
- Never allow welding electrode to touch cylinder.
- Keep cylinder away from welding or other live electrical circuits.



BUILDUP OF SHIELDING GAS may harm health or kill.

- Shut off shielding gas supply when not in use.

SEE AMERICAN NATIONAL STANDARD Z-49.1, "SAFETY IN WELDING AND CUTTING" PUBLISHED BY THE AMERICAN WELDING SOCIETY.

NOTE: Gas supply pressure must be regulated to a maximum of 80 psi(5.5 bar).

Customer must provide a cylinder of shielding gas, a pressure regulator, a flow control valve, and a hose from the flow valve to the gas inlet fitting of the wire drive unit.

Connect a supply hose from the gas cylinder flow valve outlet to the 5/8-18 female inert gas fitting on the back panel of the wire drive or, if used, on the inlet of the Gas Guard regulator. (See Below).

Gas Guard Regulator - The Gas Guard Regulator is an optional accessory (K659-1) on these models.

Install the 5/8-18 male outlet of the regulator to the 5/8-18 female gas inlet on the back panel of the wire drive. Secure fitting with flow adjuster key at top. Attach gas supply to 5/8-18 female inlet of regulator per instructions above.

POWER FEED 10M SINGLE/DUAL



WIRE SPINDLE PLACEMENT

The reel stand provides two mounting locations for the 2 inch diameter wire reel spindle to accommodate various reel sizes. Each mounting location consists of a tube in the center of the reel stand, and locating slots on the outside of the reel stand. The bolt, used with a plain washer and lock washer, slides through the tube from the side of the reel stand. The bolt should be threaded into the wire spindle such that the tabs on the brake mechanism align with the locating slots, then tighten.

The upper location must be used for 50-60 lb. Readi-Reels, Spools and Coils.

For smaller coils (44lb, 30lb, 10lb, etc.), the spindle can be placed in either the upper or lower location. The goal is to make the wire path from the coil to the wire drive an entry into the incoming guide tube that is as straight as possible. This will optimize wire feeding performance.

WATER CONNECTIONS (FOR WATER COOLED GUNS)

If a water cooled gun is to be installed for use with the Power Feed 10 Dual, a K590-6 Water connection kit can be installed for each gun requiring water cooling. Contained in the kit are the water lines and quick connect water line fittings that install in the wire feed head. Follow the installation instructions included in the kit. Water cooled guns can be damaged very quickly if they are used even momentarily without water flowing. To protect the gun, we recommended that a water flow sense kit be installed. This will prevent wire feeding if no water flow is present.

WIRE FEED SHUT DOWN CIRCUIT (OPTIONAL)

This option is intended as a means of disabling welding in the event that the water flow (for a water cooled gun) is not present. Water cooled guns can be quickly damaged if they are momentarily used without water flow. This matter can be avoided when a Lincoln Flow Sensor Kit (K1536-1) is applied to the wire feeder shut-down circuit.

The Flow Sensor Kit has two control leads that become electrically common when the water is flowing. When integrated with the wire feeder shut down circuit, it forms a closed (common) circuit and enables welding. In the event that water is not flowing, the Flow Sensor circuit (shut down circuit) is electrically opened which disables any further operation.

Flow Sensor Kit installation is as follows:

1. Remove rear access door of the wire feeder case.
2. Locate the shutdown circuit leads inside feeder case cavity (refer to table AA.4).
Note: The leads will be connected together with insulated (pink) quick disconnects.
3. Disconnect pink quick-connect tabs (.25 inch tab terminals).
4. Locate and remove plastic plug on rear of wire feeder case.
5. Insert Flow Sensor leads through hole.
6. Connect Flow Sensor leads with shutdown circuit leads.
7. Replace rear access door.

TABLE AA.4

	PF-10M Shutdown Leads	Feeder Cavity Location (Facing rear of unit)
Feeder 1 Shutdown	570 570 A/B	Upper Right Corner
Feeder 2 Shutdown	670 670 A	Upper Left Corner

EXAMPLES OF CONNECTING AN ARCLINK POWER WAVE SYSTEM

ArcLink Power Wave products may be configured in many different ways. The flexible system allows multiple wire feeders to be connected to the same power source. The diagrams represent some of the common methods for connecting ArcLink Products.

Important: Bench model wire feeders cannot be separated into a separate control box and wire drive for a boom system.

Common ArcLink Systems

The following Power Wave systems may all be assembled without any changes to the equipment DIP switches.

Basic Semi-Automatic System

- Great for general fabrication.

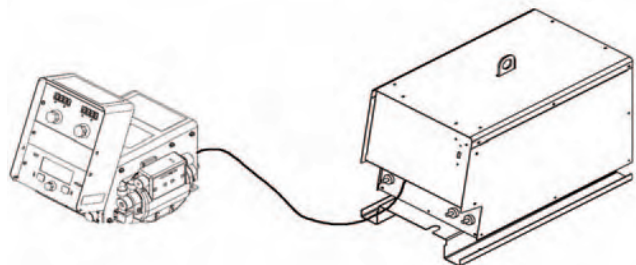

Shown with

- K2230-1 Power Feed 10M Single Wire Feeder
- K2203-1 Power Wave 455M/STT

POWER FEED 10M SINGLE/DUAL



EXAMPLES OF CONNECTING AN ARCLINK POWER WAVE SYSTEM

ArcLink Power Wave products may be configured in many different ways. The flexible system allows multiple wire feeders to be connected to the same power source. The diagrams represent some of the common methods for connecting ArcLink Products.

Important: Bench model wire feeders cannot be separated into a separate control box and wire drive for a boom system.

Common ArcLink Systems

The following Power Wave systems may all be assembled without any changes to the equipment DIP switches

Basic Semi-Automatic System

- Great for general fabrication.

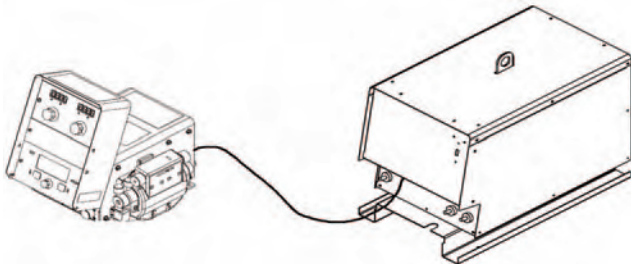

Shown with

- K2230-1 Power Feed 10M Single Wire Feeder
- K2203-1 Power Wave 455M/STT

Boom Semi-Automatic System

- Often used when making large weldments.

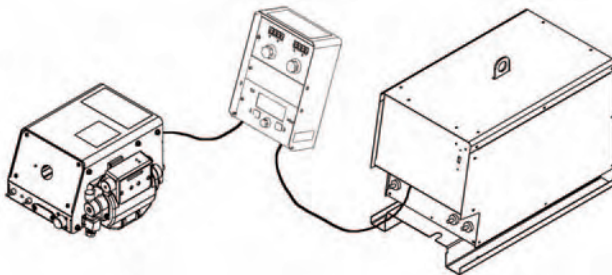

Shown with

- K2314-1 Power Feed 10M Single Wire Feeder Boom (includes wire drive and control box)
- K2203-1 Power Wave 455M/STT

Robotic/Semi-Automatic System

- Use the bench feeder for offline welding.

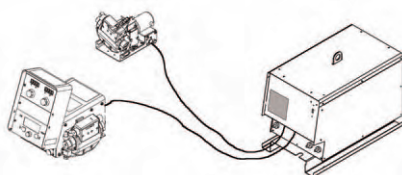

Shown with

- K2230-1 Power Feed 10M Single Wire Feeder
- K1780-2 PF-10/R
- K2203-1 Power Wave 455M/STT
- K2205-1 Wire Drive Module

Hard Automation System

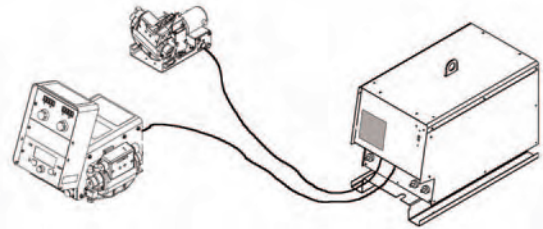

Shown with

- Control Box (not available at the time of this writing)
- K1780-2 PF-10/R
- K2203-1 Power Wave 455M/STT
- K2205-1 Wire Drive Module

Multiple Wire Feeder System

- Load one feeder with solid wire, the other with flux cored.

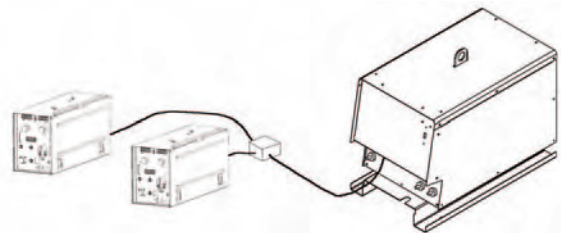

- Great for pipeline work.

Shown with

- K2429-1 ArcLink T Cable Connector
- K2196-1 Power Feed 15M
- K2203-1 Power Wave 455M/STT

ArcLink Systems

Many other ArcLink systems may be assembled besides those shown in this manual. The majority will self configure. If an assembled system flashes the status light green rapidly on all components, contact the Lincoln Electric Company for further assistance.

Current Power Feed 10M models that will not self configure...

- K2316-1 Power Feed 10M Dual Boom

These configurations will require Dip Switches to be set. See the power source instruction manual on how to disable self configuration.

POWER FEED 10M SINGLE/DUAL

TABLE OF CONTENTS - OPERATION SECTION -

Operation.....Section BB

Safety Precautions.....BB-2

Definition of Welding AbbreviationsBB-2

Common Welding AbbreviationsBB-2

Product Description.....BB-3

Recommended Processes and Equipment.....BB-3

Operation Features and Controls (Items 1 thru 5).....BB-4

 1. Wire Feed Speed (WFS)/Amp MeterBB-4

 2. Volt / Trim Meter.....BB-4

 3. Output ControlsBB-5

 4. Dual Procedure / Dual Head Select W/MemoryBB-5

 5. Mode Select Panel 4 (MSP4)BB-5/BB-7

Limit Setting.....BB-8

Setup Features Menu.....BB-8/BB-11

Dual Head/Dual Procedure with MemoryBB-12/BB-13

2 Step / 4 Step Operation.....BB-14/BB-15

Cold Feed/Gas Purge Switch.....BB-15

Hot InchBB-16

Foot Amptrol.....BB-16

Wire Drive PC Board AdjustmentsBB-16

Wire Reel Loading.....BB-16/BB-17

Feeding Electrode and Brake AdjustmentBB-18

Drive Roll Pressure Setting.....BB-18

Procedure for Setting Angle of Feedplate.....BB-18

Gas Guard Regulator SettingBB-18

Making a Weld.....BB-19

Wire Reel Changing.....BB-19

Wire Feed Overload ProtectionBB-19

Component Status Lights.....BB-20

 Status Light StatesBB-20/BB-21

 Limit SettingsBB-22



SAFETY PRECAUTIONS

Read entire Operation section before operating the Power Feed 10M Dual Wire Feeder.

WARNING



ELECTRIC SHOCK can kill.

- Do not touch electrically live parts or electrode with skin or wet clothing. Insulate yourself from work and ground.
- Always wear dry insulating gloves.



FUMES AND GASES can be dangerous.

- Keep your head out of fumes.
- Use ventilation or exhaust to remove fumes from breathing zone.

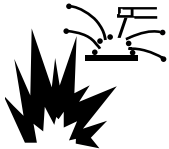

WELDING SPARKS can cause fire or explosion.

- Keep flammable material away.
- Do not weld on closed containers.



ARC RAYS can burn eyes and skin.

- Wear eye, ear and body protection.

Observe all safety information throughout this manual.

DEFINITIONS OF WELDING MODES

NON-SYNERGIC WELDING MODES

- A **Non-synergic** welding mode requires all welding process variables to be set by the operator.

SYNERGIC WELDING MODES

- A **Synergic** welding mode offers the simplicity of single knob control. The machine will select the correct voltage and amperage based on the wire feed speed (WFS) set by the operator.

COMMON WELDING ABBREVIATIONS

WFS

- Wire Feed Speed

CC

- Constant Current

CV

- Constant Voltage

GMAW (MIG)

- Gas Metal Arc welding

GMAW-P (MIG)

- Gas Metal Arc welding-(Pulse)

GMAW-PP (MIG)

- Gas Metal Arc welding-(Pulse-on-Pulse)

GTAW (TIG)

- Gas Tungsten Arc welding

SMAW (STICK)

- Shielded Metal Arc welding

FCAW

- Flux Core Arc Welding

PRODUCT DESCRIPTION

The Power Feed 10M Dual Wire Feeder unit consists of a user interface and two wire drives. This unit will be available as a bench model or a boom model.

The Power Feed 10M Dual Wire Feeder is a high performance, digitally controlled, modular wire feeder. Properly equipped, it can support the GMAW, GMAW-P, FCAW, SMAW, GTAW, and STT processes. The Power Feed 10M Dual Wire Feeder is designed to be a part of a modular, multi process welding system. The Power Feed 10M Dual Wire Feeder is a Semi-Automatic unit that is designed to interface with the Power Wave M family of welding machines. It consists of a user interface (UI) and wire drive (WD) that operate on 40VDC input power. The user interface is designed to act as a means to access the functionality (weld mode, run-in, volts, current etc.) of the welding system. The wire drive unit is a 4 driven roll feeder that can "push" various types of welding wire.

Each component in the system has special circuitry to "talk with" the other system components, so each component (power source, wire feeder, electrical accessories) knows what the other is doing at all times. This shared information lays the groundwork for a system with superior welding performance.

DUAL HEAD UNIT

Two Control PC boards: one board supports user interface and wire drive functions and second board supports second wire drive functions.

RECOMMENDED PROCESSES AND EQUIPMENT

RECOMMENDED PROCESSES

The Power Feed 10M Dual Wire Feeder can be set up in a number of configurations. They are designed to be used for GMAW, GMAW-P, FCAW and STT processes for a variety of materials, including mild steel, stainless steel, and cored wires. Other processes such as STT, SMAW and GTAW can be controlled using the user interface portion of the unit. (See Accessories Section for Part numbers and connections.

RECOMMENDED EQUIPMENT

The Power Feed 10M Dual Wire Feeder must be used with communication compatible welding equipment. That is, the communication protocol that is used in the welding system must be capable of communicating with the wire feeder. This would be any power source that has the **Arclink** receptacle available and is operating with **LincNet** or **Arclink** software.

OPERATIONAL FEATURES AND CONTROLS

POWER FEED-10M SERIES SYSTEM CONFIGURATION

The specific system component function of the pc board will be configurable by dip switch or by software configuration tool. Dip switch configuration is as follows: Refer to DIP switch settings of figures below.

Notes:

1. Basic Power Feed-10M systems consist of one User Interface (UI), and up to two wire drives (a dual head wire drive counts as two).

POWER FEED-10M DUAL BENCH DIP SWITCH SETTINGS

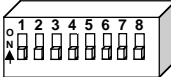
UI/WD PCB - S25629 (located on Wire Drive divider panel) 

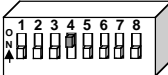
WD only PCB - S25616 (located on Wire Drive rear access door) 

POWER FEED-10M DUAL BOOM DIP SWITCH SETTINGS*

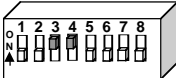
UI only PCB - S25952 (located in Control Box) 

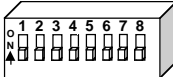
WD only PCB #1 - S25616 (located on Wire Drive divider panel) 

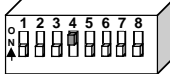
WD only PCB #2 - S25616 (located on Wire Drive rear access door) 

* See power source manual for additional dip switch settings.

CONTROLS (Refer to Figure BB.2)

1. WIRE FEED SPEED (WFS) / AMP METER

This meter displays either the WFS or current value depending on the status of the machine. Located below the display are the text "WFS" and "Amps." An LED light is illuminated next to one of these in order to indicate the units of the value displayed in the meter.

- Prior to CV operation, the meter displays the desired preset WFS value.
- Prior to CC-Stick and CC-GTAW operation, the meter displays the preset current value.
- During Welding, the meter displays actual average amps, but may be configured to display actual WFS.
- After welding, the meter holds the actual current or WFS value for 5 seconds. During this time, the display is blinking to indicate that the machine is in the "Hold" period. Output adjustment while in the "Hold" period results in the "prior to operation" characteristics stated above.

- After the 5 second "Hold" period, the meter displays the set WFS (CV modes) or Amp (CC modes) value.

2. VOLT / TRIM METER

This meter displays either the voltage or trim value depending on the status of the machine. Located below the display are the text "Volts" and "Trim." An LED light is illuminated next to one of these in order to indicate the units of the value displayed in the meter.

CV Processes

- Prior to CV-GMAW and CV-FCAW operation, the meter displays the desired preset Voltage value.
- Prior to CV-GMAW-P operation, the meter displays the desired preset Trim value.
- During Welding, the meter displays actual average volts.
- After welding, the meter holds the actual voltage value for 5 seconds. During this time, the display is blinking to indicate that the machine is in the "Hold" period. Output adjustment while in the "Hold" period results in the "prior to operation" characteristics stated above.
- After the 5 second "Hold" period, the meter displays the set Voltage (GMAW, FCAW) or Trim (GMAW-P) value.

CC Processes

- The meter displays the status of the output.
- When output is enabled, the meter will display "ON."
- When there is no output, the meter will display "OFF."

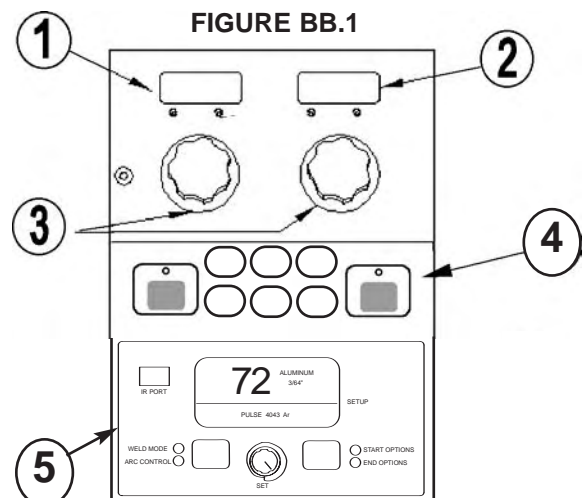

POWER FEED 10M SINGLE/DUAL



3. OUTPUT CONTROLS

- The Power Feed 10M Dual Wire Feeder has 2 encoder knobs to adjust weld parameters.
- Each encoder changes the displayed value of the meter located directly above that encoder.
- In CC-GTAW modes when equipped with a foot or hand amptrol, the left encoder sets the maximum welding current. Full depression of a foot or hand amptrol results in the preset level of current.
- In CC-Stick and CC-GTAW, the right encoder activates and de-activates the output. Turning the encoder clockwise enables the output. To de-energize the output, turn the encoder counter-clockwise. The display above will indicate the "ON" or "OFF" status of the output.

4. DUAL PROCEDURE / DUAL HEAD SELECT W/MEMORY PANEL

(See Mode Select Panel Section for a Functional Description and detailed explanation)

This panel is intended for dual head applications, and is essentially the same as the Dual Procedure with Memory panel except for the addition of a second procedure select push button. It contains two procedure select buttons, one for each head, and six memory (storage) buttons.

In general terms, dual procedure and memory are essentially independent storage locations for information.

5. MODE SELECT PANEL 4 (MSP4)

OVERVIEW:

The MSP4 is the standard mode select panel for the Power Feed 10M Dual Wire Feeder wire feeders. The MSP4 is capable of:

- Weld mode selection.
- Arc Control adjustment.
- Weld sequence control (Preflow Time, Run-in WFS, etc.)

FIGURE BB.2

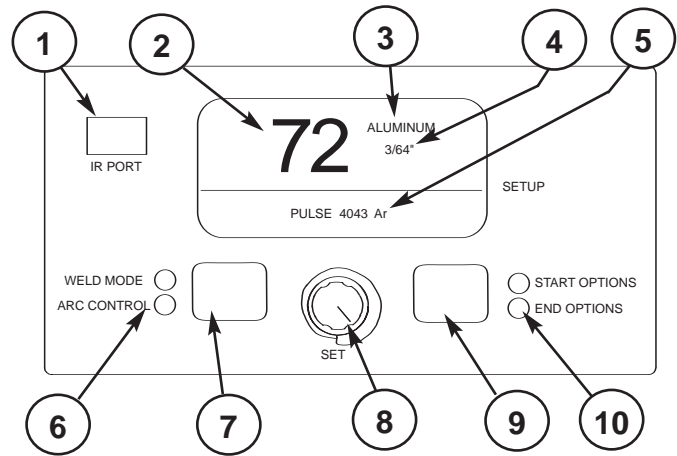

ITEM	DESCRIPTION
1	IR (Infrared) Port.
2	Weld Mode Number.
3	Weld Wire Type.
4	Wire Size.
5	Weld Mode Description.
6	Status LED Lights-Weld Mode/Arc Control.
7	Selection Pushbutton Weld Mode or Arc Control.
8	"Set" (Adjustment) Dial / Knob
9	Selection Pushbutton Start and End Options.
10	Status LED Lights-Start/End Options.

Through the use of alphanumeric displays, the MSP4 provides standard text messages designed to enhance the user's understanding of the machine's operation as well as provide advanced capabilities. The panel provides:

- Clear identification of the selected weld mode.
- Identification of weld modes not listed on the preprinted weld mode list label.
- Control of up to four wave controls (arc controls.)
- Weld mode specific wave control name display (Peak, Background, Pinch, etc.).
- Unit values are displayed (Amps, in/min, etc.).
- User-friendly machine setup and configuration.
- Limit setting for restricting the operators range of control.
- Lockout to prevent unauthorized changes to machine configuration.

Additionally, the MSP4 includes an infrared (IR) port for wireless communication and configuration using a Palm OS based hand held computer and a simplified control layout.

[Return to Section TOC](#) | [Return to Master TOC](#)

LAYOUT-CONTROLS (SEE FIGURE B.3)

The MSP4 panel controls (Items 7 and 9) set consist of an encoder knob Item 8 and two push buttons. The encoder is primarily used to change the value of the selected attribute.

The left pushbutton (Item 7) is used to toggle between Weld Mode selection and any active Arc Controls (a.k.a. wave controls). The choices of wave controls varies by weld mode. For example, weld mode 31 has one wave control, "Pinch". Weld mode 110 has three wave controls, "Peak Current", "Background Current" and "Tailout". If the selected weld mode has no wave controls, pressing the left pushbutton will have no effect. If the selected weld mode uses one or more wave controls, pressing the left pushbutton will sequence the selection from weld mode -> wave control 1 (if active) -> wave control 2 (if active) -> wave control 3 (if active) -> wave control 4 (if active) then back to weld mode.

The right pushbutton (Item 9) is used to select attributes that affect the available weld parameters such as preflow time, burnback time, etc. Since most users will require infrequent access to these attributes, they are separate from weld mode selection and wave control adjustment.

LAYOUT-DIGITAL DISPLAY

The MSP4 display consists of a large 4-digit, 7-segment LED display, two 8-character alphanumeric LED displays and one 16-character alphanumeric LED display. The information shown on the various displays depends on the state of the user interface as described below.

When the MSP4 is being used to select a weld mode, the 4-digit display (Item 2) indicates the selected weld mode number. The upper 8-character alphanumeric display (Item 3) indicates the electrode type (steel, aluminum, etc.) The lower 8-character alphanumeric display (Item 4) indicates the electrode size (.035", 1/16", etc.).

The 16-character alphanumeric display (Item 5) indicates the process type and other information, the exact content of which depends on the selected weld mode. This additional information may include specific electrode type (e.g. 4043) and/or a description of the recommended gas (e.g. HeArCO₂).

When the MSP4 is being used to change the value of an attribute, the 7-segment displays show the selected attribute's value. The upper 8-character alphanumeric display is typically not used while changing an attribute's value. The lower 8-character alphanumeric display is used to indicate the units of the selected attribute (e.g. seconds, in/min, etc.). The 16-character alphanumeric display is used to display the name of the selected attribute.

The content of the displays while the user interface is being used for advance machine configuration (e.g. limit setting, pass code entering, machine setup, etc.) is described in later sections.

POWER-UP SEQUENCE

When power is first applied to the machine, a lamp test is performed. All discrete LED's are turned on, all 7-segment displays will show a pattern of "8." and all alphanumeric displays will show a hatch pattern where every-other pixel is illuminated. The lamp test will last for two seconds, after which all displays are turned back off. The 16-character alphanumeric display will show "Initializing..." while waiting for the Weld Sequencer to announce bus available. The MSP4 alphanumeric displays will then display the name of the weld table loaded in the power source while the user interface prepares the machine for operation. After all initialization is complete, the MSP4 will display the weld mode information for the mode number that was selected when the machine was last powered down.

CHANGING WELD MODES

To select a weld mode, press the left MSP4 pushbutton until the WELD MODE LED is illuminated. Turn the MSP4 encoder until the desired weld mode number is displayed. As the MSP4 encoder knob is rotated, only the weld mode number is displayed. After 1 second of encoder idle time, the user interface will change to the selected weld mode and the new mode's electrode type, electrode size and process information will appear.

CHANGING ARC WAVE CONTROL

If the selected weld mode uses any of the four available wave controls, users can press the left MSP4 pushbutton until the ARC CONTROL LED is illuminated. The value, name and units (if applicable) of the available wave controls will appear. Note that the name of the control is derived from the weld table and may not necessarily appear as "Wave Control". Repeated pressing of the left MSP4 pushbutton will cycle through all active wave controls and then the weld mode. Turning the MSP4 encoder will change the value of the displayed wave control.

CHANGING WELD SEQUENCE BEHAVIOR

Weld sequencing attributes are grouped into two categories, START OPTIONS and END OPTIONS. START OPTIONS may include Preflow Time, Run-in Wire Feed Speed, and Start Time. END OPTIONS may include Crater Time, Burnback Time and Postflow Time. The attributes that appear in the START and END OPTIONS are weld mode dependent. For example, if a TIG weld mode is selected, Run-in WFS will not appear since it is not relevant to the selected process. Repeated pressing of the right MSP4 pushbutton will cycle through all relevant START and END OPTIONS. Turning the MSP4 encoder will change the value of the selected option.

When the Start Time attribute is set to a value other than OFF, the START OPTIONS LED will blink synchronous with the WFS and VOLTS/TRIM LED's on the dual-display panel. This blinking is used to indicate that start wire feed speed and voltage/trim can now be set to values different from those used while welding. Similarly, if the Crater Time attribute is set to a value other than OFF, the END OPTIONS LED will blink synchronously with the dual-display LED's, indicating that crater wire feed speed and voltage/trim now can be set to values different from those used while welding.

INFRARED (IR) CONTROL

The MSP4 interface includes an infrared transceiver. This allows wireless machine configuration using a Palm OS based hand held computer. A proprietary Palm OS application, ALPalm, was developed for this purpose. (Contact Lincoln Electric for more information on this feature.)

LOCKOUT/SECURITY

The MSP4 can be optionally configured to prevent the welder from changing selected MSP4 options. By default, the welder will be able to change the weld mode, all relevant wave controls and all relevant start and end options.

LIMIT SETTING

The MSP4 can be optionally configured to limit the operator's range of control of any weld parameter (weld WFS, arc control, etc.). Limits are only available with the Dual Procedure/Memory Panel.

MACHINE SETUP/USER PREFERENCES

The MSP4 can be used to configure and troubleshoot the machine.

ACCESSING THE MACHINE SETUP MENU

To access the Machine Setup menu, press both MSP4 push buttons simultaneously. The MSP4 7-segment display will display the first user preference, "P.0", and the SETUP LED will illuminate.

- Pressing the left MSP4 pushbutton will exit the entire Machine Setup menu while in the P.0 user preference.
- Turning the MSP4 encoder knob will select other available User Preferences.
- To exit the User Preference Menu, either rotate the MSP4 encoder until P.0 is displayed and press the left MSP4 pushbutton or press both MSP4 push buttons simultaneously at any time.

SETUP FEATURES MENU

The Setup Menu gives access to the set-up configuration. Stored in the setup configuration are user parameters that generally need to be set only at installation. The parameters are grouped as follows:

- P.1 through P.99 Unsecured Parameters (always adjustable)
- P.101 through P.199 Diagnostic Parameters (always read only)
- P.501 through P.599 Secured Parameters (accessible only through a p.c. or palm application.)

To access the setup menu, press the right and left buttons of the MSP4 panel simultaneously. Note that the setup menu cannot be accessed if the system is welding, or if there is a fault (The status LED is not solid green).

Change the value of the blinking parameter rotating the SET knob.

To exit the setup menu at any time, press the right and left buttons of the MSP4 panel simultaneously. Alternately, 1 minute of inactivity will also exit the setup menu.

The following list includes all possible parameters in ArcLink equipment. Not all of the parameters listed may appear for your system. Refer to the (TABLE B.1) for active parameters.

Unsecured Parameters		* PF= POWER FEED		
PARAMETER	DESCRIPTION	PF*-10M (All Models)	PF*-10A	PF*-15M
P.0	Exit set-up menu	√	√	√
P.1	WFS Units	√	√	√
P.2	Arc Display Mode	√	√	√
P.3	Display Power	√		
P.4	Trigger Memory Recall	√		
P.5	Trigger Procedure Change	√		
P.6	Stall Factor Adjustment	√		
P.7	Gun Offset Adjustment	√		
P.8	TIG Gas Control	√		
P.9	Crater Delay	√		
P.11	Set Timers	√	√	
P.12	Travel Options		√	
P.13	Adjust Arc Force		√	
P.80	Sense From Studs	√		
P.99	Show Test Modes	√	√	
Diagnostic Parameters				
P.100	View Diagnostics	√	√	√
P.101	View Event Logs	√	√	√
P.102	View Fatal Logs	√	√	√
P.103	View Software Version	√	√	√
P.104	View Hardware Version	√	√	√
P.105	View Welding Software	√	√	√
P.106	View Ethernet IP Address	√	√	√
P.107	View Power Source Type	√	√	√

POWER FEED 10M SINGLE/DUAL



Return to Section TOC
 Return to Section TOC
 Return to Section TOC
 Return to Section TOC
 Return to Master TOC
 Return to Master TOC
 Return to Master TOC
 Return to Master TOC

P.0 Press the right button to exit the setup menu.

P.1 WFS units
Metric = m/min wire feed speed units
English = In/min wire feed speed units (default)

P.2 Arc Display Mode
Amps = The left display shows Amperage while welding.
(default)
WFS = The left display shows Wire Feed Speed while welding.

P.3 Display Power
When P.3 is set to "Yes", the power will be displayed on the MSP4 while welding. When P.3 is set to "No", power will not be displayed.

P.4 Trigger Memory Recall
Enable = Selecting memories 2 through 6 with quick trigger pulls is enabled when the optional dual procedure/memory panel is installed. To recall a memory with the gun trigger, quickly pull and release the trigger the number of times that correspond to the memory number. For example, to recall memory 3, quickly pull and release the trigger 3 times. Trigger memory recall can only be performed when the system is not welding.
Disable = Memory selection is performed only by the buttons on the optional dual procedure/memory panel.
(default)

P.5 Procedure Change Method (Three Settings)
In order for any of these procedure change methods to function, the "A-Gun-B" switch must be on the "Gun" position.

1. "**External Switch**" (the default value), the machine will only change the selected procedure when the procedure select digital input changes state.
2. "**Quick Trigger**" (the optional value 1), the machine will only change the selected procedure when the trigger is released and quickly re-pulled while welding in 2-step. Enable=Allows switching between procedure A and procedure B while welding. The exception is that the procedure select digital input is no longer recognized.
3. "**Integral Trigger Procedure**" (the optional value 2), the machine will only change the selected procedure when the procedure select digital input changes state.

Machine operation is similar to the "**External Switch**" selection except that additional logic prevents procedure A from being re-selected when the trigger is quickly and completely released at step 2 of the 4-step weld sequence.

When setup parameter P.5 is set to "**Integral ProcTrig**", the machine will always operate in 2-step if a weld is

made exclusively in procedure A, regardless of the 2/4 step switch position (this is intended to simplify tack welding when using a dual-schedule gun, such as the Magnum 400 DS, while 4-step trigger is selected).

In order for any of these procedure change methods to function, the "A-Gun-B" switch must be on the "Gun" position.

P.6 Push Pull Gun, Stall Factor Adjustment
The stall factor controls the stall torque of the push motor when using a push-pull gun. The wire feeder is factory set to not stall unless there is a large resistance to feeding wire. The stall factor can be reduced to stall more easily and possibly prevent bird nesting. However, low stall factors can cause motor stalling while welding which results in the wire burning back to the tip.
If you are experiencing bird nests, check for other feeding problems before adjusting the stall factor.

Default value for the stall factor is 75, with a range of 5 - 100.

To change the stall factor:

- Use the VOLTS/TRIM knob to adjust the stall factor. Increasing the stall factor raises the motor torque and decreasing the stall factor lowers the motor torque. Do not increase the stall factor more than necessary. A high stall factor may increase the occurrence of bird nesting and a low stall factor may cause the wire to burn back to the tip.

P.7 Push Pull Gun, Gun Offset Adjustment
The push-pull gun offset calibration adjusts the wire feed speed calibration of the pull motor. The procedure should only be performed when other possible corrections do not solve the push-pull feeding problems. A rpm meter is required to perform the pull gun motor offset calibration.

To perform the calibration procedure:

- Release the pressure arm on both the pull and push wire drives.
- Set the wire feed speed to 200 ipm.
- Remove wire from the pull wire drive.
- Hold the rpm meter to the drive roll in the pull gun.
- Pull the trigger on the push-pull gun.
- Measure the rpm of the pull motor. The rpm should be between 115 and 125 rpm. If necessary, decrease the calibration setting to slow the pull motor, or increase the calibration setting to speed up the motor. The calibration range is -30 to +30, with 0 as the default value.

- P.8 TIG Gas Control (Two Settings)**
1. "**Valve (manual)**", the internal solenoid will not actuate while TIG welding, gas flow is manually controlled by an external valve.
 2. "**Solenoid (auto)**", the internal gas solenoid will turn on and off automatically while TIG welding as follows:
 - Preflow time will not be accessible from the MSP4.
 - Postflow time will be available in the MSP4 "End Options" and have a range of OFF to 10.0 seconds.
 - The postflow time value is maintained when switching between MIG and TIG modes.
 - When machine output on/off is controlled via the right encoder, gas flow will not start until the tungsten touches, the work piece, gas flow will stop after the postflow time when the arc is broken.
 - When machine output on/off is controlled via an arc start switch or foot Amptrol, gas will begin flowing when the output is turned on and stop flowing after the postflow period after the output is turned off.
- P.9 Crater Delay**
This parameter enables a timer delay for each feed head to bypass the Crater option when short tack welds are desired. If the trigger is released before the timer expires, Crater will be bypassed and the weld will end. If the trigger is released after the timer expires, Crater will function as normal (if Crater function is turned on).
- P.11 Set Timers**
This menu is used to adjust timer values for Upslope, Downslope and Restrike. Press the right button to enter the Set Timer menu. Rotate the knob to select the timer to adjust and then press the right button. Adjust the value of the timer by rotating the knob. Press the left MSP4 button to set the value and exit. Continue to adjust other timers as necessary, and then press the left button to exit the Set Timer menu.
- P.12 Travel Options**
This menu is used to change the travel options for a travel carriage, including starting and ending functions. The right MSP4 button to enter the Travel Options menu and rotate the encoder to select either starting or ending options. Press the right MSP4 button to select the option. Press the left MSP4 button to set the value and exit. Rotate the encoder to select other options, or press the left MSP4 button to exit the menu.
- P.13 Adjust Arc Force**
Use this menu to adjust Arc Force values for Start, Weld and Crater. Press the right MSP4 button to enter the menu and rotate the knob to choose either Start, Weld or Crater. Press the right MSP4 button and then rotate the knob to the desired value. Press the left MSP4 button to set the value and exit.
- Continue to adjust Arc Force for other states, and then press the left MSP4 button to exit the menu.
- P.80 Sense From Studs (two settings)**
1. "**False**", the voltage sense lead is automatically selected based on the DIP switch configuration and the selected weld mode. This is the default value that is used every time the machine is powered up. Note that setting P.80 to "**False**" does not preclude voltage sensing from the studs if studs sensing is specified by the selected weld mode (for example stick and TIG weld modes will still sense voltage at the studs).
 2. "**True**", voltage sensing is forced to "studs" regardless of the DIP switch configuration and selected weld mode. Setting P.80 to "**True**" should only be done for troubleshooting purposes. P.80 will automatically be set back to "**False**" the next time the equipment is powered up or can be manually changed back to "**False**" via the setup menu.
- In order to control the welding arc, the power source continually monitors arc current and arc voltage. Arc current is measured internal to the power source. Arc voltage can be measured as follows:
- Voltage internal to the power source ("studs")
 - Voltage at the wire feeder ("67" lead)
 - Voltage at a user-wired sense lead ("21" lead)
- Remote voltage sensing (anything other than "studs") is used to obtain a more accurate voltage measurement since the sense lead is closer to the arc. Remote voltage sensing can involve external wiring and DIP switch configuration, there is a potential for incorrect voltage measurement which can lead to poor arc control or wire burn back.

- | | | | |
|-------|---|-------|--|
| P.99 | <p>Show Test Modes
Many weld tables include special modes for testing and servicing the welding system. Set this parameter to YES to show all test modes.</p> <p>When the power source is turned off, the Show Test Modes parameter automatically reverts back to "NO".</p> | P.105 | <p>Welding Software
Press the right MSP4 button to view the welding software version inside the power source. Press the left MSP4 button to exit.</p> |
| P.100 | <p>View Diagnostics
Diagnostics are only used for servicing the Power Wave system.
Yes = Shows P.101 through P.500 in the SETUP menu.
No = Only P.0 through P.100 are shown in the SETUP menu.</p> | P.106 | <p>Ethernet IP Address
Press the right MSP4 button to view the IP address of the Ethernet board. If no Ethernet Board is installed, the display shows "No Enet Found." Press the left MSP4 button to exit.</p> |
| P.101 | <p>Event Logs
Press the right MSP4 button to view the Event Logs. Rotate the encoder to select the object to read and then press the right MSP4 button. Various software information will appear about key system events. Press the left MSP4 button to exit.</p> | P.107 | <p>Power Source
Press the right MSP4 button to view the type of power source connected to the control box. Press the left MSP4 button to exit.</p> |
| P.102 | <p>Fatal Logs
Press the right MSP4 button to view the Fatal Logs. Rotate the encoder to select the module to read and then press the right MSP4 button. Various software information will appear about critical module actions. Press the left MSP4 button to exit.</p> | | |
| P.103 | <p>Software Version
Press the right MSP4 button to view the software loaded into each module (p.c. board). Rotate the encoder to select the module to read and then press the right MSP4 button. The panel will display the main software version loaded into the module. Press the left MSP4 button to exit.</p> | | |
| P.104 | <p>Hardware Version
Press the right MSP4 button to view the hardware version of each module (p.c. board). Rotate the encoder to select the module to read and then press the right MSP4 button. The panel will display the main hardware version loaded into the module. Press the left MSP4 button to exit.</p> | | |

FIGURE BB.3

- Head / Procedure Select

 - Press to select head or change active procedure.
 - Changes to weld settings affect active procedure only.
 - Only one procedure can be active at a time.
 - Can change from A to B during a weld.

Memory

 - Permanent storage for procedure settings.
 - Six available memory locations. One procedure (A or B) can be stored in each.
 - Press to recall contents into active procedure.
 - Press and Hold to save active procedure into memory location.
 - Not accessible during welding.

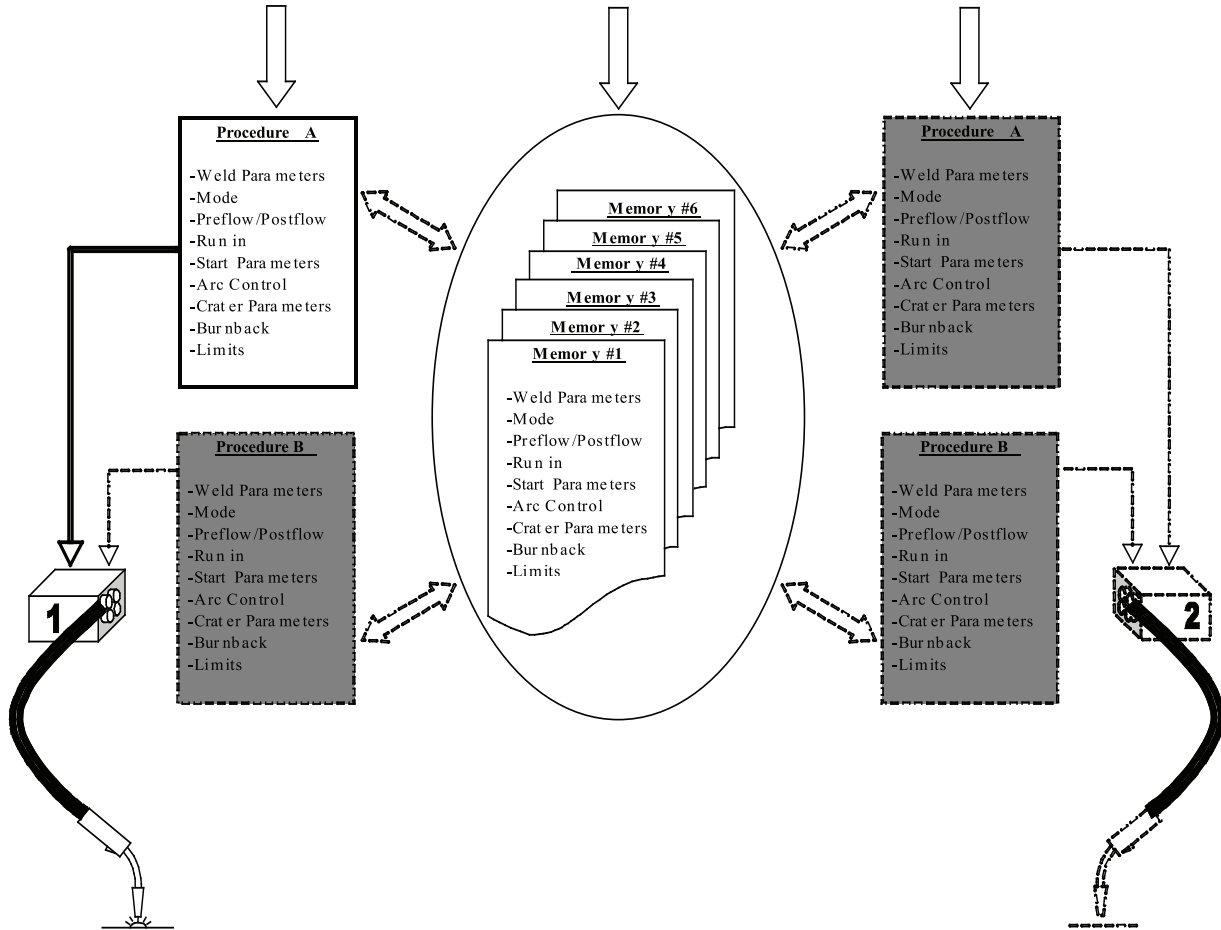
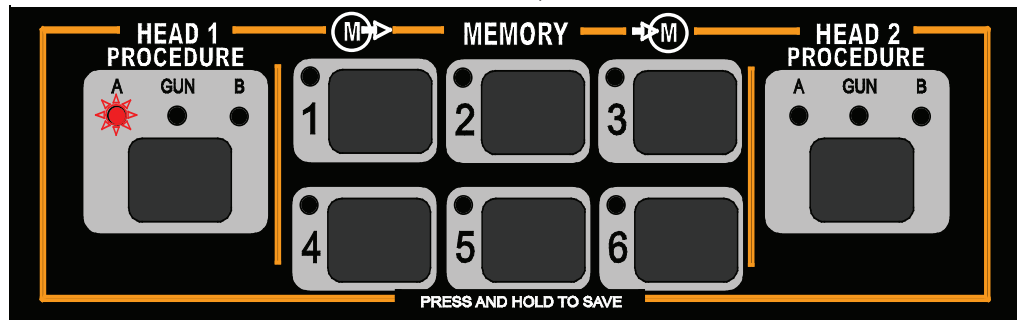

POWER FEED 10M SINGLE/DUAL



Return to Section TOC

Return to Section TOC

Return to Section TOC

Return to Section TOC

Return to Master TOC

Return to Master TOC

Return to Master TOC

Return to Master TOC

Each procedure contains/stores the following information:

- Basic weld parameters as applicable - WFS, Volts, Trim, Amps
- Weld Mode - Mode Number
- Preflow/Postflow - Time in Seconds
- Run in - WFS Only (work point determined by next active sequence state)
- Start Parameters - Status, Slope Time, WFS, Volts, Trim, Amps
- Arc Control - Setpoint
- Crater Parameters - Status, Slope Time, WFS, Volts, Trim, Amps
- Burnback - Time in Seconds
- Limits - All applicable limits.

DUAL HEAD / DUAL PROCEDURE WITH MEMORY

In general terms, dual procedure and memory are essentially independent storage locations for information. Procedures can be thought of as temporary or working storage locations because they contain the weld settings readily available for use, and when active, are easily modified. The dual procedure feature allows the operator to switch between procedures (A and B) "on the fly" while welding. In addition to their procedure set-up functions, the procedure select push buttons serve as a means to manually select the active feed head (wire drive). Memory is more of a permanent storage location that cannot be accessed while welding. It contains one complete set of procedure information which can be recalled into the active procedure (A or B). Conversely, the active procedure can be saved into memory for safe keeping.

Dual Procedure / Head Select

This feature allows the user to select Procedure A, Gun (Remote Select), or Procedure B, as well as selecting the active feed head (wire drive). The active feed head is indicated by the procedure group (A, Gun, B) with the illuminated LED(s), and only one procedure group / feed head can be active at a time. Changing the active feed head can be done in one of two ways. Either remotely, by pulling the trigger of the inactive feed head, or locally by momentarily depressing the procedure select pushbutton of the inactive head.

When a procedure group / feed head is active, momentarily depressing the procedure select pushbutton will change from A to Gun, from Gun to B, or from B to A. The corresponding LED will be lit to let the user know which procedure is active. When the Gun position is selected, the Gun LED will be solid red, and the active procedure LED (A or B) will be flashing.

The active procedure is determined by the dual procedure (Gun) input located in the gun receptacle, or through the "Procedure Change with Trigger" feature if properly configured.

Note:

When in the Gun position, if no dual procedure (Gun) switch is plugged in, the Procedure defaults to A.

There are a total of four independent procedures available on this panel. Two for each feed head.

Both the contents of the active procedure, and the active procedure itself (A to B, or B to A) can be changed "on the fly" during welding. Changing the active status of the feed head can only be done when the system is in the idle state. Procedure settings for each feed head, and active procedure information are saved at power down.

Memory

This feature allows the user to save and recall up to six individual procedures to/from a secured storage location. Each of the six memory locations is capable of storing a complete copy of the information associated with a single procedure (A or B) including its individual limits. See the complete list above.

Memories can be accessed at anytime, except when welding. For wire fed processes this means anytime a trigger is NOT activated. For CC processes it means anytime current is NOT flowing.

Saving to Memory

To save an individual procedure (A or B) to memory, first be sure the desired procedure of the desired feed head is active (its LED is on). Press and hold the button of the memory location you wish to store the procedure into. After 2 seconds, the LED above the memory button will begin to flash indicating that the procedure has been saved. The LED will continue to flash as long as the memory button is depressed. When released the memory LED will stay on steady, and remain lit as long as the contents of the memory remain equal to the contents of the associated procedure.

If the memory button is released before the light begins to flash ($t < 2s$), a memory recall function will occur instead of a save function (i.e. the contents of the selected memory will copied to the active procedure).

Note:

It is not required to load all 6 memories at once, nor is it necessary to load them in order.

Recalling from Memory

To recall the contents of a memory into the active procedure, momentarily push the desired memory button (for less than 2 seconds). The saved parameters will be copied into the active procedure, and the LED of the memory button will light indicating the source of the information. As with saving to memory, this light will remain lit as long as the contents of the source memory remain equal to the contents of the associated procedure.

If a constant current mode is saved to memory with the power source in the "on" state, the "on" status will be changed to "off" when the procedure is recalled. This prevents a potential safety hazard if a memory button is pushed and the power source unexpectedly turns on.

2 STEP / 4 STEP OPERATION

The Wire Drive has a 2 Step / 4 Step switch located near the gun connector. 2-Step Trigger Mode operation requires the operator hold the gun trigger closed in order to weld. 4-Step Trigger Mode eliminates the need to hold the gun trigger closed while welding. User-selectable 4-step modes with or without current interlock. The switch in the down position will enable 2-Step operation and in the up position enables 4-Step operation. This switch has no effect in CC modes of operation, such as stick welding. Both 2 and 4-Step can be operated in Synergic and Non-Synergic modes. In a Synergic mode, machine output tracks Wire Feed Speed (WFS) during welding. In Non-Synergic modes, machine output is independent of WFS.

2 Step Synergic Operation:

Without Start/Crater/Burnback functions active

Waveform Sequence:

1. Trigger is pulled; Preflow sequence begins and runs until preflow timer expires.
2. Strike sequence initiates until Arc is established.
3. Arc established; Weld sequence begins.
4. Trigger released (Arc extinguished); Postflow sequence begins and runs until postflow timer expires.
5. End of sequence.



WFS vs. Work point Waveform

—= solid line represents **WFS**
 ---= dashed line represents **Work point or Machine Output**

**2 Step Synergic Operation:
 With Burnback function active.**

Waveform Sequence:

1. Trigger is pulled; Preflow sequence begins and runs until preflow timer expires.
2. Run-In sequence initiates until Arc is established.
3. Arc established; Weld sequence begins.
4. Trigger released (Arc extinguished); Burnback sequence begins and runs until burnback timer expires.
5. Postflow sequence begins and runs until postflow timer expires.
6. End of sequence.



WFS vs. Work point (Output) Waveform

—= solid line represents **WFS**
 ---= dashed line represents **Work point or Machine Output**

**2 Step Synergic Operation:
 With Start/Crater/Burnback functions active.**

Waveform Sequence:

1. Trigger is pulled; Preflow sequence begins and runs until preflow timer expires.
2. Run-In sequence initiates until Arc is established.
3. Arc established; Start sequence begins and runs for the amount of time set.
4. Weld sequence begins.
5. Trigger released; Crater sequence begins and runs until crater timer expires.
6. Arc Extinguished; Burnback sequence begins and runs until burnback timer expires.
7. Postflow sequence begins and runs until postflow timer expires.
8. End of process.

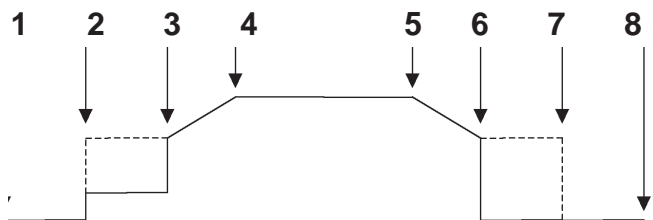

WFS vs. Work point (Output) Waveform

—= solid line represents **WFS**
 ---= dashed line represents **Work point or Machine Output**

POWER FEED 10M SINGLE/DUAL



Return to Section TOC
 Return to Master TOC
 Return to Section TOC
 Return to Master TOC
 Return to Section TOC
 Return to Master TOC
 Return to Section TOC
 Return to Master TOC

4 Step Synergic Operation: Without Start/Crater/Burnback functions active

Waveform Functionality:

1. Trigger is pulled and released; Preflow sequence begins and runs until Preflow timer expires.
2. Run-In sequence begins and runs until Arc is established
3. Arc established; Weld sequence begins.
4. Trigger pulled; Weld sequence continues.
Note: This can be done anytime between Step 3 and 5.
5. Trigger released; Postflow sequence begins and runs until Postflow timer expires.
6. End of sequence.

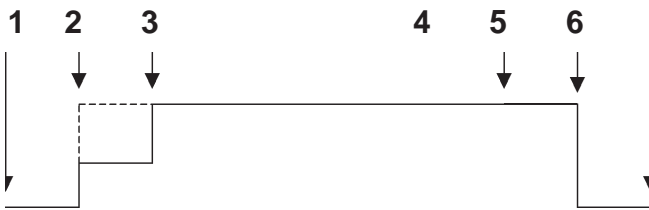

WFS vs. Work point Waveform

— = solid line represents WFS
--- = dashed line represents **Work point** or **Machine Output**

4 Step Synergic Operation: With Start/Crater/Burnback functions active

Waveform Functionality:

1. Trigger is pulled and released; Preflow sequence begins and runs until Preflow timer expires.
2. Run-In sequence begins and runs until Arc is established.
3. **Arc established**; Work point moves to set value in Start sequence.
4. **Trigger released**; Step 4 to 5 is start time set in Start sequence to get to Weld sequence.
5. Weld sequence begins and runs until trigger is pulled.
6. **Trigger pulled and held**; Crater sequence begins. Work point, WFS move to set value in Crater sequence in the amount of time set within Crater sequence.
7. Work point, WFS Crater values held until trigger is released.
8. **Trigger released**; Burnback sequence begins and runs until Burnback timer expires.
9. Postflow sequence begins and runs until Postflow timer expires.
10. End of sequence.

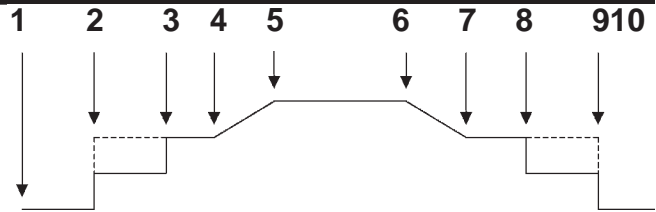

WFS vs. Work point (Output) Waveform

— = solid line represents WFS
--- = dashed line represents work point or machine output

Additional Comments:

- To achieve a Hot Start routine, the values in step 2 (Run-In and Strike) can be set such that work point (output) is set to a desired level, while the Weld work point level will be set to a normal or nominal level for the particular process.

Example Strike Value: 350A

Strike Time: 0.1 sec.

Weld Value: 170A

When the process is initiated, the work point will jump to Strike work point of 350A with the set Run-In WFS. When the trigger is released, the work point will jump to 170A in the 0.1 seconds and the Weld sequence will begin, traversing through the rest of the sequence using the functions set forth.

COLD FEED/GAS PURGE SWITCH

The Wire Drive has a Cold Feed/Gas Purge Switch located near the gun connector. This is an up/down center-off momentary toggle switch.

When held in the up position, the Wire Drive will feed wire, but neither the power source nor the gas solenoid will be energized. When cold feeding, the feed speed can be adjusted by rotating the WFS encoder knob on the Control Box. Adjusting the cold feed will not affect the run in or welding wire feed speed. When the cold feed switch is released, the cold feed value is saved.

When this switch is held in the down position, the gas solenoid valve is energized, but neither the power source nor the drive motor will be energized.

HOT INCH

Hot inch occurs when the trigger is pulled and an arc is not established. After a 1.5 second period, the Sequencer will jump to the Weld state and the wire feeder will run at the preset wire feed speed on the display. The wire is hot (output is on) at this point. Start, Upslope, Downslope, Crater, Burnback, Postflow, etc are all skipped when Hot Inch is activated.

FOOT AMPCTRL

A Foot Ampctrl Kit can be installed in order to operate the output of the machine using a pedal. Located on the Control Box, the Right encoder turns output on/off if desired. The left encoder sets the max work point limit. When the pedal is pressed OCV will be present and gas will not flow. As soon as the tungsten touches the work and there is current flow, the gas solenoid will turn on. If the arc breaks the machine will enter the postflow state. When the postflow timer expires, the machine will return to OCV mode and no gas will flow until the arc is established. If the pedal is released it turns the machine off, postflow will be entered until time out. When the postflow timer expires the machine will return to idle state and wait for trigger. Preflow will be pre-settable for external triggers if desired. Triggering machine with encoder will skip preflow.

WIRE DRIVE -- PC BOARD ADJUSTMENTS

ELECTRODE POLARITY:

The system needs to be aware of the electrode polarity. A DIP switch setting on the Wire Drive PC boards is used for this purpose. See INSTALLATION Section "Setting DIP Switches in the Wire Drive".

GEAR BOX RATIO:

The systems needs to know which gear has been installed on the Wire Drive, low or high speed. A DIP switch setting on the Wire Drive PC boards is used for this purpose. See INSTALLATION section "Wire Drive Ratio" for information on how to set the DIP Switch.

WIRE REEL LOADING - READI-REELS, SPOOLS OR COILS

To Mount a 30 Lb. (14 kg) Readi-Reel Package (Using the Molded Plastic K363-P Readi-Reel Adapter:)

The Spindle should be located in the **LOWER** mounting hole.

- 1) Depress the Release Bar on the Retaining Collar and remove it from the spindle. **See Figure BB.4.**
- 2) Place the Adapter on the spindle.
- 3) Re-install the Retaining Collar. Make sure that the Release Bar "pops up" and that the collar retainers fully engage the retaining groove on the spindle.
- 4) Rotate the spindle and adapter so the retaining spring is at the 12 o'clock position.
- 5) Position the Readi-Reel so that it will rotate in a direction when feeding so as to be de-reeled from bottom of the coil.
- 6) Set one of the Readi-Reel inside cage wires on the slot in the retaining spring tab.
- 7) Lower the Readi-Reel to depress the retaining spring and align the other inside cage wires with the grooves in the molded adapter.
- 8) Slide cage all the way onto the adapter until the retaining spring "pops up" fully.

CAUTION

Check to be sure the Retaining Spring has fully returned to the locking position and has **SECURELY** locked the Readi-Reel Cage in place. Retaining Spring must rest on the cage, not the welding electrode.

-
- 9) To remove Readi-Reel from Adapter, depress retaining spring tab with thumb while pulling the Readi-Reel cage from the molded adapter with both hands. Do not remove adapter from spindle.

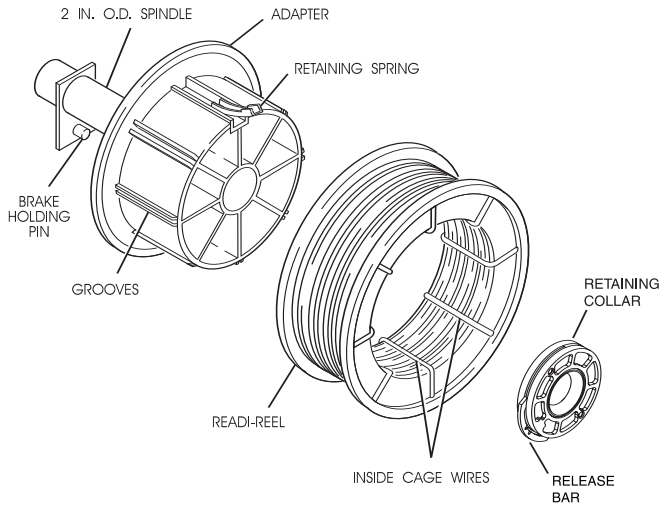

FIGURE BB.4

To Mount 10 to 44 Lb. (4.5-20 kg) Spools (12"/300 mm Diameter) or 14Lb.(6 Kg) Innershield Coils:

The Spindle should be located in the **LOWER** mounting hole.

(For 8" (200 mm) spools, a K468 spindle adapter must first be slipped onto spindle.)

(For 13-14 lb. (6 Kg) Innershield coils, a K435 Coil Adapter must be used).

- 1) Depress the Release Bar on the Retaining Collar and remove it from the spindle.
- 2) Place the spool on the spindle making certain the spindle brake pin enters one of the holes in the back side of the spool. Be certain the wire comes off the reel in a direction so as to de-reel from the bottom of the coil.
- 3) Re-install the Retaining Collar. Make sure that the Release Bar "pops up" and that the collar retainers fully engage the retaining groove on the spindle.

To Mount a 50-60 Lb. (22.7-27.2 kg) Coil: (Using K1504-1 Coil Reel) (For 50-60 lb Readi-Reels a K438 Readi-Reel Adapter must be used).

The Spindle must be located in the **UPPER** mounting hole.

- 1) With the K1504-1 Coil Reel mounted on to the 2" (51 mm) spindle (or with reel laying flat on the floor) loosen the spinner nut and remove the reel cover. See Figure BB.5.
- 2) Before cutting the tie wires, place the coil of electrode on the reel so it unwinds from the bottom as the reel rotates.

- 3) Tighten the spinner nut against the reel cover as much as possible by hand using the reel cover spokes for leverage. **DO NOT** hammer on the spinner nut arms.
- 4) Cut and remove only the tie wire holding the free end of the coil. Hook the free end around the rim of the reel cover and secure it by wrapping it around. Cut and remove the remaining tie wires.

⚠ CAUTION

Always be sure the free end of the coil is securely held while the tie wires are being cut and until the wire is feeding through the drive rolls. Failure to do this will result in "backlashing" of the coil, which may tangle the wire. A tangled coil will not feed so it must either be untangled or discarded.

- 5) Be sure the coil reel is engaged with the spindle brake pin and the Release Bar on the Retaining Collar "pops up" and that the collar retainers fully engage the retaining groove on the spindle.

FIGURE BB.5

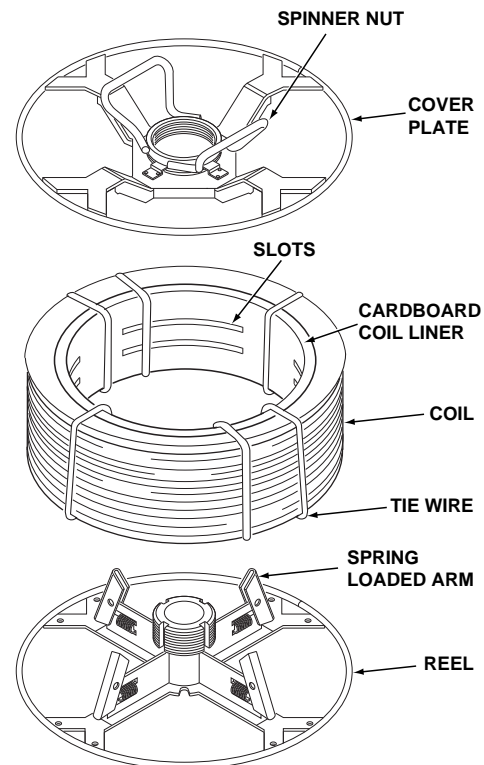

FEEDING ELECTRODE AND BRAKE ADJUSTMENT

- 1) Turn the Reel or spool until the free end of the electrode is accessible.
- 2) While tightly holding the electrode, cut off the bent end and straighten the first 6" (150 mm). Cut off the first 1" (25 mm). (If the electrode is not properly straightened, it may not feed or may jam causing a "birdnest".)
- 3) Insert the free end through the incoming guide tube.
- 4) Press the Cold Inch key or the Cold Feed Mode gun trigger and push the electrode into the drive roll.

When feeding with the gun trigger, unless "COLD

WARNING

FEED" trigger mode is selected, the electrode and drive mechanism are always "HOT" to work and ground and could remain "HOT" several seconds after the gun trigger is released.

- 5) Feed the electrode through the gun.
- 6) Adjust the brake tension with the thumbscrew on the spindle hub, until the reel turns freely but with little or no overrun when wire feeding is stopped. Do not overtighten.

DRIVE ROLL PRESSURE SETTING

The Power Feed 10 Dual Wire Feeder pressure is factory pre-set to about position "2" as shown on the pressure indicator on the front of the feedplate door. This is an approximate setting.

The optimum drive roll pressure varies with type of wire, surface condition, lubrication, and hardness. Too much pressure could cause "birdnesting", but too little pressure could cause wire feed slippage with load and/or acceleration. The optimum drive roll setting can be determined as follows:

- 1) Press end of gun against a solid object that is electrically isolated from the welder output and press the gun trigger for several seconds.
- 2) If the wire "birdnests", jams, or breaks at the drive roll, the drive roll pressure is too great. Back the pressure setting out one turn, run new wire through gun, and repeat above steps.
- 3) If the only result is drive roll slippage, disengage the gun, pull the gun cable forward about 6" (150 mm). There should be a slight waviness in the exposed wire. If there is no waviness, the pressure is too low. Increase the pressure setting one turn, reconnect the gun, tighten locking clamp and repeat the above steps.

PROCEDURE FOR SETTING ANGLE OF FEEDPLATE

- 1) Loosen the clamping collar screw using a 3/16" Allen wrench. The clamping collar screw is accessed from the bottom of the feedplate. It is the screw which is perpendicular to the feeding direction.
- 2) Rotate feedplate to the desired angle and tighten clamping collar screw.

GAS GUARD REGULATOR SETTING

- 1) With the gas supply shut off, the Gas Guard regulator flow adjusting Key should be set to maximum (full clockwise) which is rated to be 60 SCFH (28 l/min).
- 2) Adjust gas supply flow rate for a level higher than will be required, then adjust Gas Guard flow adjusting Key counterclockwise to the desired gas flow rate.

MAKING A WELD

- 1) Use only a network compatible power source.
- 2) Properly connect the electrode and work leads for the correct electrode polarity.
- 3) Set all desired parameters such as trigger logic, Run-in Speed, Acceleration, Electrode polarity, etc. per "DIP SWITCH SETUP" in the INSTALLATION section.
- 4) Set 2-step, 4-step switch on wire drive to desired mode of operation. (Refer to "2-step/4-step switch operation" in this section.)
- 5) Select Weld Mode. (Refer to Control Box Operation in this section).
- 6) Use Control Select switches, increment/decrement switches, and encoder knobs to set desired parameters for weld depending on what options are installed. (Refer to Control Box Operation in this section).
- 7) Feed the electrode through the gun and cable and then cut the electrode within approximately .38" (9.5 mm) of the end of the contact tip for solid wire and within approximately .75" (19mm) of the extension guide for cored wire.
- 8) Connect work cable to metal to be welded. Work cable must make good electrical contact to the work. The work must also be grounded as stated in "Arc Welding Safety Precautions".

WARNING



When using an Open Arc process, it is necessary to use correct eye, head, and body protection.

- 9) If used, be sure shielding gas valve is turned on.
- 10) Position electrode over joint. End of electrode may be lightly touching the work.
- 11) Lower welding helmet, close gun trigger, and start welding. Hold the gun so the contact tip to work distance gives the correct electrical stickout as required for the procedure being used.
- 12) To stop welding, release the gun trigger and then pull the gun away from the work after the arc goes out and Postflow time, if used, is over.

- 13) If required, starting can be optimized by adjusting the acceleration and/or run-in speed. (Refer to Control Box Operation in this section).

WIRE REEL CHANGING

At the end of a coil, remove the last of the old electrode coil from the conductor cable by either pulling it out at the nozzle end of the gun or by using the following procedure:

- 1) Cut the end of the electrode off at the gun end. Do not break it off by hand because this puts a slight bend in the wire making it difficult to pull it back through the nozzle.
- 2) Disconnect the gun cable from the gun connector on the Power Feed 10 Dual wire drive unit and lay the gun and cable out straight.
- 3) Using pliers to grip the wire, pull it out of the cable from the connector end.
- 4) After the electrode has been removed, reconnect the gun cable to the drive. Load a new reel of electrode per the instructions in "Wire Reel Loading" in this section.

WIRE FEED OVERLOAD PROTECTION

The wire drive provides overload protection of the wire drive motor. If the wire drive motor becomes overloaded for an extended period of time the wire drive will issue a shutdown command to the Control Box and force it's status light to blink between green and red. The Control Box turns off the power source, wire feed and gas solenoid. The status light on the wire drive will continue to blink between green and red for about 30 seconds before the wire drive will automatically reset. At that time, the wire drive will issue a shutdown over command to the Control Box that will return the system to normal operation. The wire drive will force it's status light to solid green.

Overloads can result from improper tip size, liner, drive rolls, or guide tubes, obstructions or bends in the gun cable, feeding wire that is larger than the rated capacity of the feeder or any other factors that would impede normal wire feeding. (See "Avoiding Wire Feeding Problems" in the MAINTENANCE section).

POWER FEED 10M SINGLE/DUAL



COMPONENT STATUS LIGHTS

Each network component has a single status light. The light is a bicolor, Green/Red, LED. The purpose of the status light is to allow the operator to quickly identify that the system is working properly or, if not, which

component is causing the problem. By using the status lights the operator can quickly pinpoint the system problem to a particular component. See the following table for a complete listing and description of all status light conditions.

NOTE: The green light **ON and steady** indicates a normal functioning system.

STATUS LIGHT STATES

LED State	Power Source LED	LED on any other nodes (components); Wire Feeder, Control Box Etc.
Off	Power Source is not turned ON or is not functioning correctly.	The system component is not receiving input power or is faulty.
Green LED blinking at a "normal" rate	It should only blink for a few seconds while the system is mapping (identifying components). If blinking continues every group may have a mapping error. (DIP switches may be set incorrectly).	It should only blink for a few seconds until the system component (node) has been recognized. If the blinking continues at least one node in the group has a mapping error (DIP switches may be set incorrectly). The node or nodes with mapping errors will be blinking red. <ul style="list-style-type: none"> • There may be too many components in the group. All components in the group will be blinking green. • The power source bus may not be available. The bus may be being used to program another component. • The LED's of the power source and the component being programmed will be solid green.
Red LED blinking at a "normal" rate	Indicates a recoverable communication fault. The power source should automatically recover: If it cannot recover the LED will be solid red.	Indicates a recoverable communication fault most likely caused by one of the following. <ul style="list-style-type: none"> • More than one control box (UI) in the group. All control boxes in the group will be blinking red. • No control box (UI) in the group. All nodes in the group will be blinking red. • More than one node, of the same equipment type, has the same group and feed head (FH) numbers. All these nodes will be blinking red. • The feed head DIP switches may be set to zero. The nodes with DIP switches set to zero will be blinking red. • The node bus may be off.
Red/Green LED blinking at a "normal" rate	Indicates a recoverable hardware fault such as over temperature, overload shutdown etc.	Indicates a recoverable hardware fault such as over temperature, overload shutdown etc. Could also be an open shutdown circuit at the feed head (leads 570, 572 with tab terminals) typically used for water flow shutdown switches.

POWER FEED 10M SINGLE/DUAL



Return to Section TOC

Return to Section TOC

Return to Section TOC

Return to Section TOC

Return to Master TOC

Return to Master TOC

Return to Master TOC

Return to Master TOC

STATUS LIGHT STATES (CON'T)

LED State	Power Source LED	LED on any other nodes (components); Wire Feeder, Control Box Etc.
Red LED blinking at a fast rate	Power source needs to be reprogrammed. Contact your Local Authorized Lincoln Field Service Facility.	System component (node) needs to be reprogrammed. Contact your Local Authorized Lincoln Field Service Facility.
Red LED ON and steady	Power source has a non-recoverable hardware fault. Contact your Local Authorized Lincoln Field Service Facility.	System component (node) has a non-recoverable hardware fault. Contact your Local Authorized Lincoln Field Service Facility.
Green LED ON and steady	System normal and functional.	System normal and functional.

Normal Blinking LED - Each illumination should exist for 0.5 seconds.

Fast Blinking LED - Each illumination should exist for 0.1 seconds.



Return to Section TOC
Return to Master TOC

LIMIT SETTING

Each user memory can be optionally configured to limit the user's range of control over some user interface settings. By default, user limits are not enabled. To set limits for a selected memory, first select a weld mode and perform a memory save. Next, press and hold the memory button for five seconds. Release the memory button when the memory LED begins to blink rapidly and the Mode Select Panel displays indicate "Set Limits".

If the pass code has been set to a value other than zero, the user will be prompted to enter it. If the pass code is zero, the Mode Select Panel will immediately display the Limit Setup menu and the SETUP LED will illuminate:

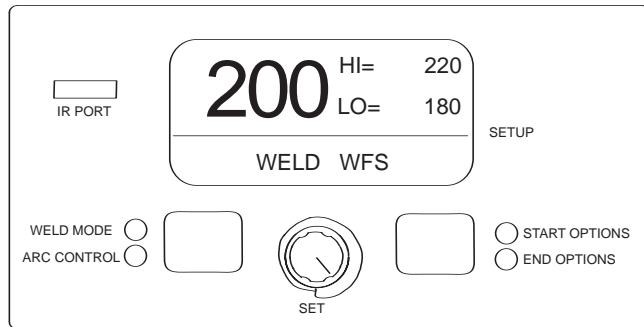

The above example shows a wire mode, constant current weld modes would show "Weld Amps" rather than "Weld WFS".

There are four items displayed on each Limit Setup screen. The long alphanumeric display shows the selected attribute (e.g. Weld WFS,Volts, etc.). The short alphanumeric displays show the selected attribute's high and low user limits. The 7-segment displays show the value that is copied to procedure memory when a memory recall is performed.

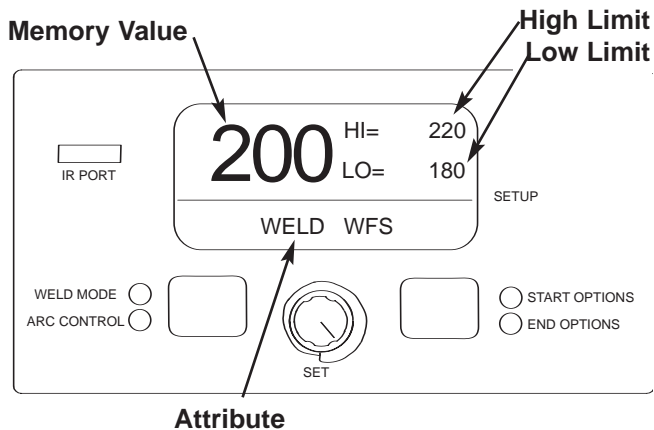

One of these four items will blink to indicate which item will change when the Mode Select Panel Knob is rotated. Initially, the selected item will be the attribute. To select the high limit, press either Mode Select Panel button and the high limit value will begin to blink. Pressing either Mode Select Panel button again will cause the memory value to blink, pressing a third time will cause the low limit to blink.

Weld modes cannot be selected from the Limits Setup menu; the mode must be selected and saved to memory prior to entering the Limits Setup menu.

The memory value, high and low limit values are bound by the limits of the machine. For example, weld mode 49 may allow the wire feed speed to be adjusted between 10 and 200 in/min. These are referred to as "machine limits". Machine limits can vary between power sources and are also weld mode dependent.

The memory value must always be less than or equal to the high limit and greater than or equal to the low limit. The high limit must always be greater than or equal to the low limit and the low limit must always be less than or equal to the high limit. The rules are enforced automatically. If the low limit is increased above the memory value, the memory value will automatically increase.

To lock an attribute to a specific value, set the high and low limits to the desired value. The user will not be able to change it.

After setting limits, press the memory button that is flashing. The Mode Select Panel displays will prompt the user to save or discard the limit changes just made.

By pressing the Mode Select Panel button labeled YES, changes to limits are saved and user limits are automatically enabled. By pressing NO, any changes made to limits are discarded and the limit enable/disable state is not changed.

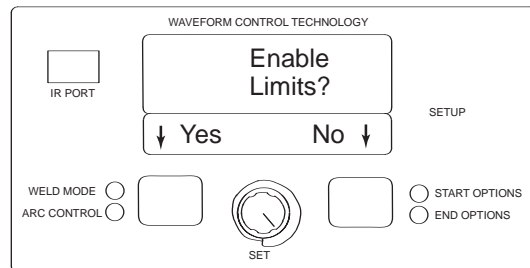

To enable or disable limits that have been established for any memory, press and hold the respective memory button in for more than 10 seconds until the Mode Select Panel displays "Enable Limits?" Pressing "Yes" will use the established limits, while pressing "No" will ignore the established limits. The limits that have been set for any memory location will not be erased if they are disabled.

TABLE OF CONTENTS - ACCESSORIES SECTION -

Return to Master TOC

Return to Master TOC

Return to Master TOC

Return to Master TOC

AccessoriesSection CC

Drive Roll and Guide Tube Kits	CC-2
Other Accessories	CC-3/CC-6

POWER FEED 10M SINGLE/DUAL



TABLE CC.1 – DRIVE ROLL AND GUIDE TUBE KITS

Wire Size		4-Roll DH Drive (4-Driven)
<u>Solid Steel Electrode</u>		
0.023" - 0.025"	(0.6 mm)	KP1505 - 030S
0.030"	(0.8 mm)	KP1505 - 030S
0.035"	(0.9 mm)	KP1505 - 035S
0.040"	(1.0 mm)	KP1505 - 045S
0.045"	(1.2 mm)	KP1505 - 045S
0.052"	(1.4 mm)	KP1505 - 052S
1/16"	(1.6 mm)	KP1505 - 1/16S
5/64"	(2.0 mm)	KP1505-5/64
3/32"	(2.4 mm)	KP1505-3/32
<u>Cored Electrode</u>		
0.030	(0.8 mm)	KP1505 - 035C
0.035"	(0.9 mm)	KP1505 - 035C
0.040"	(1.0 mm)	KP1505 - 045C
0.045"	(1.2 mm)	KP1505 - 045C
0.052"	(1.4 mm)	KP1505 - 052C
1/16"	(1.6 mm)	KP1505 - 1/16C
0.068"	(1.7 mm)	KP1505 - 068
5/64"	(2.0 mm)	KP1505 - 5/64
3/32"	(2.4 mm)	KP1505 - 3/32
7/64"	Lincore Hard Facing (2.8mm)	KP1505 - 7/64H
7/64"	(2.8mm)	KP1505 - 7/64
.120"	(3.0mm)	KP1505 - 120
<u>Aluminum Electrode</u>		
0.035"	(0.9 mm)	KP1507 - 035A
0.040"	(1.0 mm)	KP1507 - 040A
3/64"	(1.2 mm)	KP1507 - 3/64A
1/16"	(1.6 mm)	KP1507 - 1/16A
3/32"	(2.2 mm)	KP1507 - 3/32A

POWER FEED 10M SINGLE/DUAL



Return to Section TOC

Return to Master TOC

Return to Section TOC

Return to Master TOC

Return to Section TOC

Return to Master TOC

Return to Section TOC

Return to Master TOC

FIELD INSTALLED OPTIONS/ACCESSORIES

• OPTIONAL CONTROL PANEL KITS

- Armlink Cables
 - Without Weld Cable

Cable Lengths: 8 ft	K1543-8
16 ft	K1543-16
25 ft	K1543-25
50 ft	K1543-50
100 ft	K1543-100
- Co-Axial Power Cable

Cable Length: 25 ft. (350 amps)	K1796-25
50 ft. (350 amps)	K1796-50
75 ft. (325 amps)	K1796-75
100 ft. (325 amps)	K1796-100
- Weld Power Cables
 - Lug to Lug - 3/0, 600A, 60% Duty Cycle, 10 ft
K1842-1
 - Lug to Lug - 3/0, 600A, 60% Duty Cycle, 35 ft
K1842-35
 - Lug to Lug - 3/0, 600A, 60% Duty Cycle, 60 ft
K1842-60
 - Lug to Lug - 3/0, 600A, 60% Duty Cycle, 110 ft
K1842-110
- Feed Plate Gun Receiver Bushings. For use with:
 - Lincoln Gun Connector (K466-1)
 - Innershield/SubArc Guns K1500-1
 - Tweco® 4 Gun Connector (K466-2, K466-10)
 - Magnum 200/300/400 Guns K1500-2
 - Tweco® 5 Gun Connector (K1637-7)
 - Magnum 550 Guns K1500-3
 - Miller® Adapted Gun (K466-3) K1500-4
 - OXO® Gun K1500-5
 - Fast Mate Guns K489-7
 - Magnum 200/300/400 to K1500-2 Adapter K466-2
 - K613-7 Magnum 550 to K1500-3 Adapter K613-7
- Incoming Bushings

- Lincoln Conduit .025-1/16"	K1546-1
- Lincoln Conduit 1/16-1/8"	K1546-2
- Wire Straightener
 - For 10-Series Feed Heads
or Separate Mounting K1733-1
- Spindle Adapters
 - For Mounting Readi-Reels and
2" I.D. Spools up to 60 lbs. K162-1
 - For Mounting Readi-Reels and
2" I.D. Spools up to 60 lbs. K162-1H
 - For 14 lb. Innershield Coils to be
mounted on 2" O.D. Spools K435
 - For 8" O.D. Small spools (10-12.5 lbs.)
to be mounted on 2" O.D. spindles K468

- Readi-Reel Adapters
 - Adapts 22-30 lb. Readi-Reels
to a 2" Spindle K363P
 - Adapts 50-60 lb. Readi-Reels
to a 2" Spindle K438
- Coil Adapter
 - Adapts 50-60 lb. Lincoln coils
to a 2" Spindle K1504-1
- Plastic Wire Cover for
30-44 lb. Wire Packages K1634-1
- Plastic Wire Cover for up
to 60 lb. Wire Packages K1634-2
- Water Connection Kit K590-6
- Water Connection Adapter KP1529-1
- Magnum Flow Sensor K1536-1
- Gas Guard Regulator K659-1
- Dual Procedure Switch (5 pin)
with Trigger Leads K683-3
- Large Panel Security Door K1574-1
- Swivel Platform K1557-1
- Light Duty Caster Kit K1556-1
- Insulated Lift Bail K1555-1

K162-1 - WIRE SPINDLE ADAPTER

Spindle for boom mounting Readi-Reels and 2" (51 mm) I.D. spools with up to 60 lb. (27.2 kg) capacity. User mounted to appropriately prepared boom framework. Includes an easily adjustable friction brake for control of overrun (a 2" spindle is standard on Power Feed 10 Dual Bench model).

When a 2" (51 mm) spindle is used with Readi-Reels, or coils not on 12" (305 mm) or 8" (203 mm) O.D. spools, an adapter is required:

K1504-1 - COIL ADAPTER

Permits 50 lb to 60 lb (22.7-27.2 Kg.) coils to be mounted on 2" (51 mm) O.D. spindles.

POWER FEED 10M SINGLE/DUAL



K435 - COIL ADAPTER

Permits 14 lb. (6 kg) Innershield coils to be mounted on 2" (51 mm) O.D. spindles.

K363P - READI-REEL ADAPTER

Adapts Lincoln Readi-Reel coils of electrode 30 lb. (14 kg) and 22 lb. (10 kg) to a 2" (51 mm) spindle. Durable molded plastic one piece construction. Designed for easy loading; adapter remains on spindle for quick changeover.

K438 - READI-REEL ADAPTER

Adapts Lincoln Readi-Reel coils of electrode 50-60 lb. (22.7-27.2 kg) to a 2" (51 mm) spindle

GUNS AND GUN ADAPTERS

The Power Feed 10 Dual wire feeder is equipped with a factory installed K1500-2 gun connection Kit. This kit is for guns having a Tweco™ #2-#4 connector. The Power Feed 10 Dual has been designed to make connecting a variety of guns easy and inexpensive with the K1500 series of gun connection kits. Gun trigger and dual procedure lead connections connect to the single 5 pin receptacle on the front of the wire drive box.

MAGNUM 200/300/400 GUNS

The easiest and least expensive way to use Magnum 200/300/400 guns with the Power Feed 10 Dual wire feeder is to order them with the K466-10 connector kit, or to buy a completely assembled Magnum gun having the K466-10 connector (such as the K471-21, -22, and -23 dedicated Magnum 400 guns and the K497-20 and -21 dedicated Magnum 200 guns).

MAGNUM 550 GUNS

The easiest and least expensive way to use the Magnum 550 guns with Power Feed 10 Dual wire feeders is to order the gun with the K613-2 connector kit, and install a K1500-3 gun connection kit to the wire feeder.

LINCOLN INNERSHIELD AND SUB ARC GUNS

All of these guns can be connected to the Power Feed by using the K1500-1 Adapter Kit.

LINCOLN FUME EXTRACTION GUNS

The K556 (250XA) and K566 (400XA) guns require that a K489-7 Fast-Mate™ adapter kit be installed.

The K206, K289, and K309 require only the installation of a K1500-1 connector in the Power Feed wire feeder.

NON-LINCOLN GUNS

Most competitive guns can be connected to the Power Feed by using one of the K1500 series adapter kits.

GUN RECEIVER BUSHINGS AND ADAPTERS

K489-7 (DUAL SCHEDULE FAST-MATE ADAPTER)

This adapter installs directly into the wire drive feed-plate, to provide for use of guns with Fast-Mate or European style gun connections. This K489-7 will handle both standard Fast-Mate and Dual Schedule Fast-Mate guns.

K1500-1 (LINCOLN INNERSHIELD GUN STANDARD CONNECTION)

Use this kit to connect the following guns: Guns having a Lincoln standard innershield gun connector, Magnum 200/300/400 with K466-1 connector kit, and Magnum 550 guns with the K613-1 gun connection kit.

K1500-2 (TWECO #2-#4 TYPE CONNECTION)

The K1500-2 gun adapter comes factory installed on the Power Feed 10 Dual wire feeder. Use this adapter for guns that have a Tweco #2-#4 connector. Such guns include Magnum 200/300/400 guns with K466-2 connector kit, and completely factory assembled Magnum guns that are factory equipped with the K466-2 connector (such as the K471-21, -22, and -23 dedicated Magnum 400 guns and the K497-20 and -21 Magnum 200 guns).

K1500-3 (TWECO #5 CONNECTION)

For Magnum 550 gun with K613-2 Connection Kit, and any other gun having a Tweco #5 connector .

POWER FEED 10M SINGLE/DUAL



K1500-4 (MILLER CONNECTION)

For any gun having a newer style Miller connector. Install gun adapters per the instructions shipped with it.

K1500-5 (OXO CONNECTION)

For any gun having an OXO style connector. Install gun adapters per the instructions shipped with it.

CONDUIT ADAPTERS**K1546-2 ADAPTER**

for use with Lincoln Magnum conduit and E-Beam conduit (wire sizes 1/16 - .120)

For Magnum conduit:

Install the K1546-2 gun adapter at the incoming end of the feed plate, secure with the set screw located at the back of the feed plate. If a brass fitting is supplied with the conduit, remove it from the feeder end of the conduit by unscrewing it. Insert the conduit into the K1546-2, secure the conduit by fastening it the the adapter with the supplied knob screw.

For E-Beam Conduit:

Install the K1546-2 gun adapter at the incoming end of the feed plate, secure with the set screw located at the back of the feed plate. Insert the conduit into the K1546-2, secure the conduit by fastening it the the adapter with the supplied knob screw.

DUAL PROCEDURE SWITCH OPTIONS**K683-3 DUAL PROCEDURE SWITCH**

Kit includes gun switch, and mountings for Lincoln Innershield and Magnum guns, with 15 ft. (4.5m) control cable and 5-pin plug with two leads to connect to gun trigger.

Connect the 5-pin plug of the K683-3 Dual procedure Switch to the Power Feed 10 Dual Wire Feeder Trigger/Dual Procedure 5-socket receptacle.

The two lead plug cord extending out of the 5-pin plug of the Dual Procedure switch is to be connected to the two trigger leads of the welding gun per instructions shipped with the kit.

K683-1 DUAL PROCEDURE SWITCH

The K683-3 Dual Procedure Switch is the recommended method of obtaining dual procedure for non-Fast-Mate guns; but a K683-1 can be used. For using a K683-1 with a fast mate gun, see USING DUAL PROCEDURE WITH FAST-MATE GUNS. A K683-1 Dual Procedure Switch can be used on the Power Feed 10 Dual if a K686-2 adapter is used. The K686-2 kit includes the gun switch and mountings for Lincoln Innershield and Magnum guns, with 15 ft. (4.5 m) control cable and 3-pin plug. K686-2 Adapter permits the 3-pin plug from the K683-1 and 5-pin gun trigger plug to be connected to the 5-pin trigger/dual procedure receptacle on the wire feeder.

USING DUAL SCHEDULE WITH FAST-MATE GUNS ON -10 SERIES FEEDERS

Configuration 1

K489-7 Dual Schedule Fast-Mate adapter

K575-[] Magnum 400 DS/FM gun (or competitive DS/FM gun)

Configuration 2*

K489-7 Dual Schedule Fast-Mate adapter

K683-1 Dual Procedure Switch (3 pin)

K686-2 "Y" adapter (3pin + 5 pin to 5 pin)

* Non-DS Fast-Mate gun (Magnum 450WC, Magnum 200, Magnum 300, Magnum 400, and others)

K590-6 WATER CONNECTION KIT

Install per the instructions shipped with the kit.

K1536-1 WATER FLOW SENSOR KIT

Install per the instructions shipped with the kit

K659-1 GAS GUARD REGULATOR

Adjustable flow regulator with removable adjuster key for CO2 and Argon blend gases. Mounts onto feeder inlet, and reduces gas waste and arc start “blow” by reducing surge caused by excess pressure in supply hose.

Install the 5/8-18 male outlet of the regulator to the 5/8-18 female gas inlet on the back panel of the wire drive. Secure fitting with flow adjuster key at top. Attach gas supply to 5/8-18 female inlet of regulator per INSTALLATION section.

K1556-1 LIGHT DUTY CASTER KIT

This option provides 4 casters and all required hardware to mount it to the Power Feed Wire Feeder.

K1555-2 INSULATED LIFT HOOK

For applications where an insulated lift hook is required. This kit provides an easily installed, heavy duty insulated lift eye that mounts to the wire reel stand mast. See the instructions provided with the kit for installation.

K1546-1 CONDUIT ADAPTER

Install per the Instructions shipped with the Kit.

**K1551-2 INCOMING BUSHING (4 Ball Roller)
(Standard on codes 10600 and up)**

This ball bearing equipped incoming bushing can be used in place of the standard incoming wire bushing, when feeding solid steel or cored wire electrodes. It significantly reduces any abrasion to the electrode wire where it enters the feed head. This results in even smoother, more trouble free operation.

K1733-1 WIRE STRAIGHTENER

Install per the Instructions shipped with the Kit.

K2339-1 PUSH-PULL KIT AND K2320-1 FOOT AMPROL AMPHENOL

The push-pull kit provides direct connection of a Cobra Gold or Prince XL torch to the Power Feed 10M Dual Wire Feeder wire feeder.

The kit is intended for use with the following Cobra Max, Python or Prince XL torches:

Cobra Max	
K2252-1	Air Cooled 15ft.(4.5m)
K2252-2	Air Cooled 25ft.(7.6m)
Python	
	K2212-1 Water Cooled 15ft.(4.5m)
K2211-2	Air Cooled 25ft.(7.6m)
	K2212-2 Water Cooled 25ft.(7.6m)
K2211-3	Air Cooled 50ft.(15.6m)
	K2212-3 Water Cooled 50ft.(15m)
Prince XL	
	K1592-1 Water Cooled 15ft.(4.5)
K2296-2	Air Cooled 25ft.(7.6)
	K1592-2 Water Cooled 25ft.(7.6)
	K1592-3 Water Cooled 50ft.(15.6)

⚠ CAUTION

Remove all input power to the Power Feed 10M Dual Wire Feeder before installing the Connection Adapter Kit.

⚠ WARNING

Refer to the Owner’s Manual of the Torch for Amperage and Duty Cycle rating information. The torch rating may not match the rating of the power source.

MAKING A WELD WITH THE PRINCE XL OR COBRA GOLD TORCH INSTALLED

- Set the idle roll pressure on the wire drive between an indicator reading of 0-2. A recommended start point is 1.5.
- Depending on the weld mode, set the Voltage or Trim at the Power Feed 10M Dual Wire Feeder using the right control knob located on the upper case front panel.
- The Wire Feed Speed (WFS) is set using the control knob on the Torch. The left control knob on the Power Feed 10M Dual Wire Feeder is inactive. The actual WFS being set at the torch is displayed on the Power Feed 10M Dual Wire Feeder.
- All weld parameters normally available for the active weld mode are available during push-pull operation. Refer to the Operation Section of this manual.

Return to Section TOC
 Return to Master TOC
 Return to Section TOC
 Return to Master TOC
 Return to Section TOC
 Return to Master TOC
 Return to Section TOC
 Return to Master TOC

TABLE OF CONTENTS - MAINTENANCE SECTION -

Return to Master TOC

Return to Master TOC

Return to Master TOC

Return to Master TOC

MaintenanceSection DD

Safety PrecautionsDD-2

Routine Maintenance.....DD-2

Wire Reel Mounting - Readi-Reels and 10 through 30lb (4.5-14kg) SpoolsDD-2

Avoiding Wire Feeding ProblemsDD-2

Periodic Maintenance.....DD-2

Procedure for Removing Feedplate from Wire FeederDD-2

POWER FEED 10M SINGLE/DUAL



MAINTENANCE

Safety Precautions

WARNING



ELECTRIC SHOCK can kill.

- Do not touch electrically live parts such as output terminals or internal wiring.
- When inching with gun trigger, electrode and drive mechanism are "hot" to work and ground and could remain energized several seconds after the gun trigger is released.
- Turn OFF input power at welding power source before installation or changing drive roll and/or guide tubes.
- Welding power source must be connected to system ground per the National Electrical Code or any applicable local codes.
- Only qualified personnel should perform maintenance work.

Observe all additional Safety Guidelines detailed throughout this manual.

ROUTINE MAINTENANCE

Gun and Cable connection: After feeding every coil of wire; check tightness of gun connection to wire feed brass bushing.

Drive Rolls and Guide Tubes

After feeding every coil of wire, inspect the drive roll section. Clean it as necessary. The driver rolls and Inner Wire Guides are stamped with the wire sizes they will feed. If a wire size other than that stamped on the roll(s) is to be used, the roll(s) and Inner Wire Guides must be changed.

All drive rolls have two identical grooves. The rolls may be flipped over to use the other groove.

See "Procedure to Install Drive Rolls and Wire Guides" in the INSTALLATION section for roll changing instructions.

Wire Reel Mounting - Readi-Reels and 10 through 30lb (4.5-14kg) Spools

No routine maintenance required.

Avoiding Wire Feeding Problems

Wire feeding problems can be avoided by observing the following gun handling and feeder set up procedures:

- a) Do not kink or pull cable around sharp corners.
- b) Keep the electrode cable as straight as possible when welding or loading electrode through cable.
- c) Do not allow dolly wheels or trucks to run over cables.
- d) Keep cable clean by following maintenance instructions.
- e) Use only clean, rust-free electrode. The Lincoln electrodes have proper surface lubrication.
- f) Replace contact tip when the arc starts to become unstable or the contact tip end is fused or deformed.
- g) Do not use excessive wire spindle brake settings.
- h) Use proper drive rolls, wire guides and drive roll pressure settings.

PERIODIC MAINTENANCE

- Every year inspect the gearbox and coat the teeth with a Moly-disulfide grease. **Do Not** use graphite grease.
- Every six months check the motor brushes. Replace them if they are less than 1/4" long.
- Replace the drive rolls and inner wire guide when they are worn.
- Replace the pig tail if the insulation is cut, abraded or damaged.

Gun and Cable Maintenance

See appropriate Operator's Manual.

Procedure for Removing Feedplate from Wire Feeder

- 1) Loosen the clamping collar screw using a 3/16" Allen wrench. The clamping collar screw is accessed from the bottom of the feedplate. It is the screw which is perpendicular to the feeding direction.
- 2) Loosen the retaining screw, which is also accessed from bottom of feeder, using a 3/16" Allen wrench. Continue to loosen the screw until the feedplate can be easily pulled off of the wire feeder.

POWER FEED 10M SINGLE/DUAL



- 1. CONTROL BOX ASSEMBLY
- 2. WIRE DRIVE ASSEMBLY
- 3. MOTORS ASSEMBLY
- 4. GEAR BOX ASSEMBLY
- 5. SPINDLE ASSEMBLY
- 6. REEL STAND ASSEMBLY

FIGURE DD.1 - MAJOR COMPONENT LOCATION

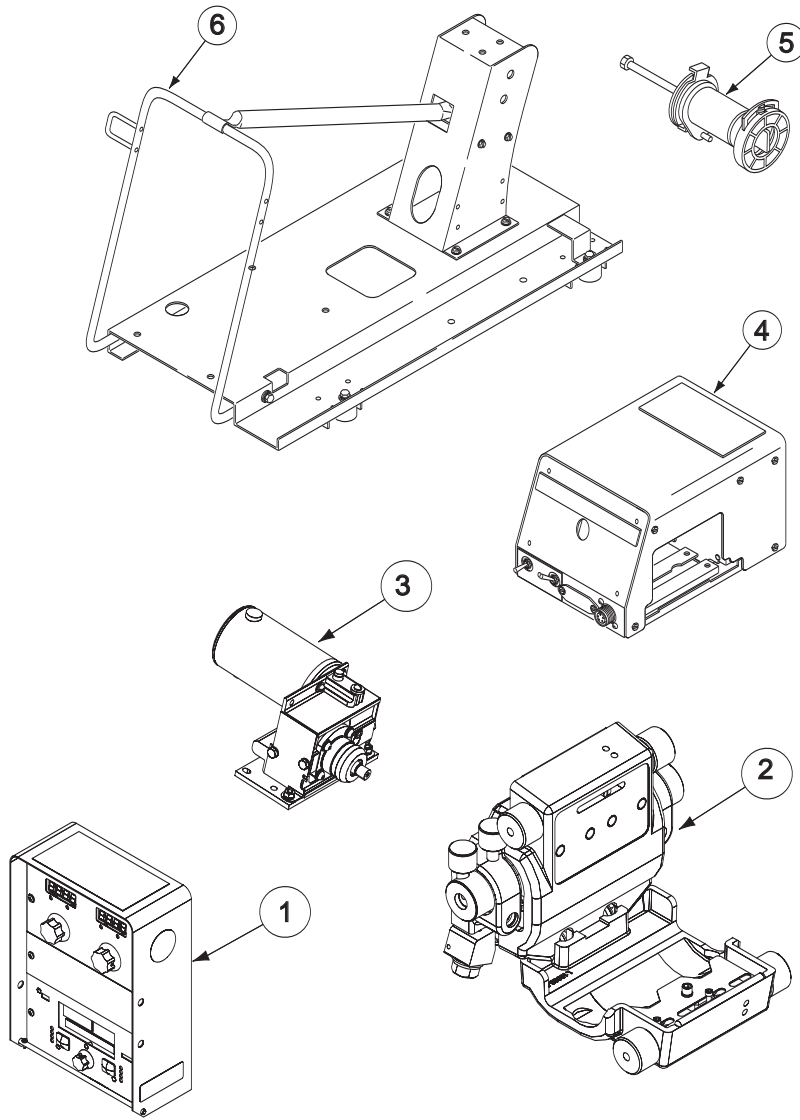

POWER FEED 10M SINGLE/DUAL



Return to Section TOC

Return to Section TOC

Return to Section TOC

Return to Section TOC

Return to Master TOC

Return to Master TOC

Return to Master TOC

Return to Master TOC

Return to Section TOC
Return to Master TOC
Return to Section TOC
Return to Master TOC
Return to Section TOC
Return to Master TOC
Return to Section TOC
Return to Master TOC

POWER FEED 10M SINGLE/DUAL



FIGURE E.2 – GENERAL DESCRIPTION

Theory of Operation.....	Section E
General Physical Description.....	E-1
General Functional Description	E-1
Feed Head	E-2
Control Box (User Interface)	E-3

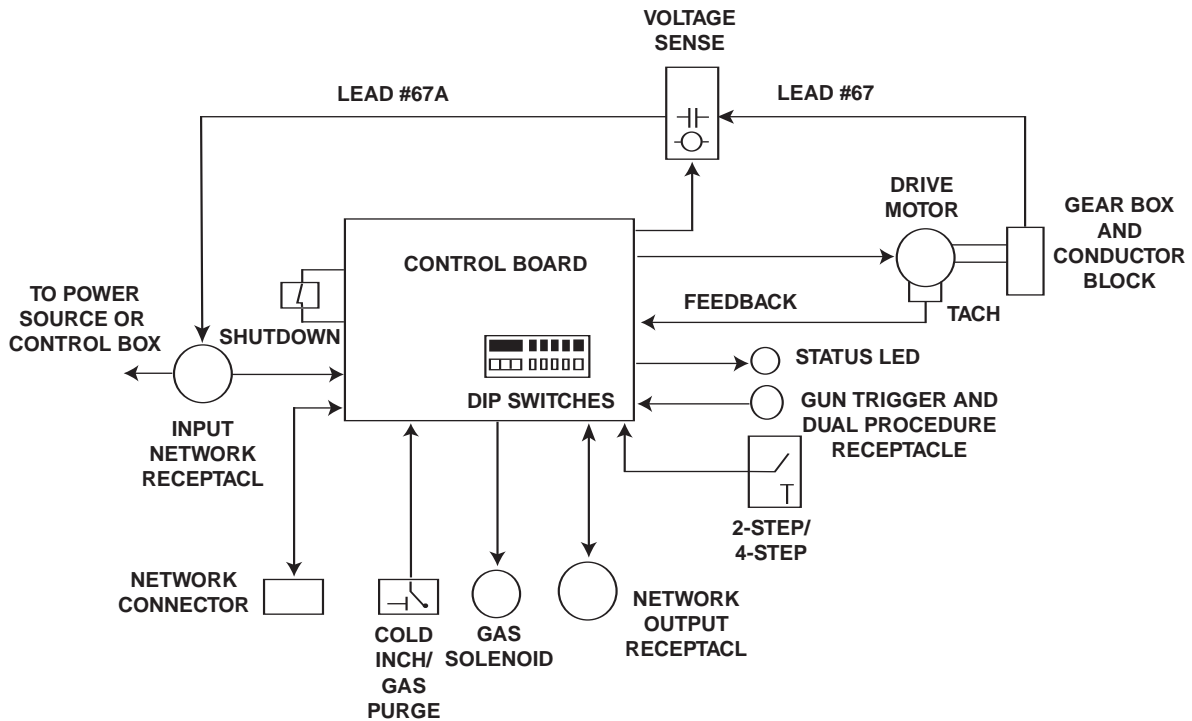

General Physical Description

The Power Feed 10M Single Wire Feeder is a modular wire feeder, consisting of two components - a **wire drive** and a **control box** - are available assembled as a **bench unit** or as a **boom system**. High speed, highly reliable digital cables connect the components together and to the Power Wave power source.

The Power Feed 10M Single Wire Feeder system has the ability to connect multiple wire feeders to one power source, use the same power source to weld in two different locations (not simultaneously), or load a different electrode on each feeder to eliminate change over time.

The powerful four roll wire drive system sets the industry standard for ease of use. Its patented design allows for tool-less change out of wire guides and drive rolls greatly reducing set up time.

General Functional Description

- The Power Feed 10M Single Wire Feeder is a highly versatile wire feeder with easy to use features that make it easy for the operator to adjust the arc for specific preferences.
- The new MSP4 panel clearly displays key welding information. Use the MSP4 panel to quickly adjust weld settings, arc starting parameters, arc end parameters and set-up variables.
- The Power Feed 10M Single Wire Feeder wire feeder is provided with an infrared red (IR) port. Transferring welding settings from one wire feeder to another is accomplished with a common palm computer.
- When the Power Feed 10M Single Wire Feeder is coupled to a Power Wave welding power source, the result is a welding system with absolutely superior arc performance.

POWER FEED 10M SINGLE/DUAL



Return to Section TOC

Return to Section TOC

Return to Section TOC

Return to Section TOC

Return to Master TOC

Return to Master TOC

Return to Master TOC

Return to Master TOC

FIGURE E.2 – POWER FEED 10M FEED HEAD

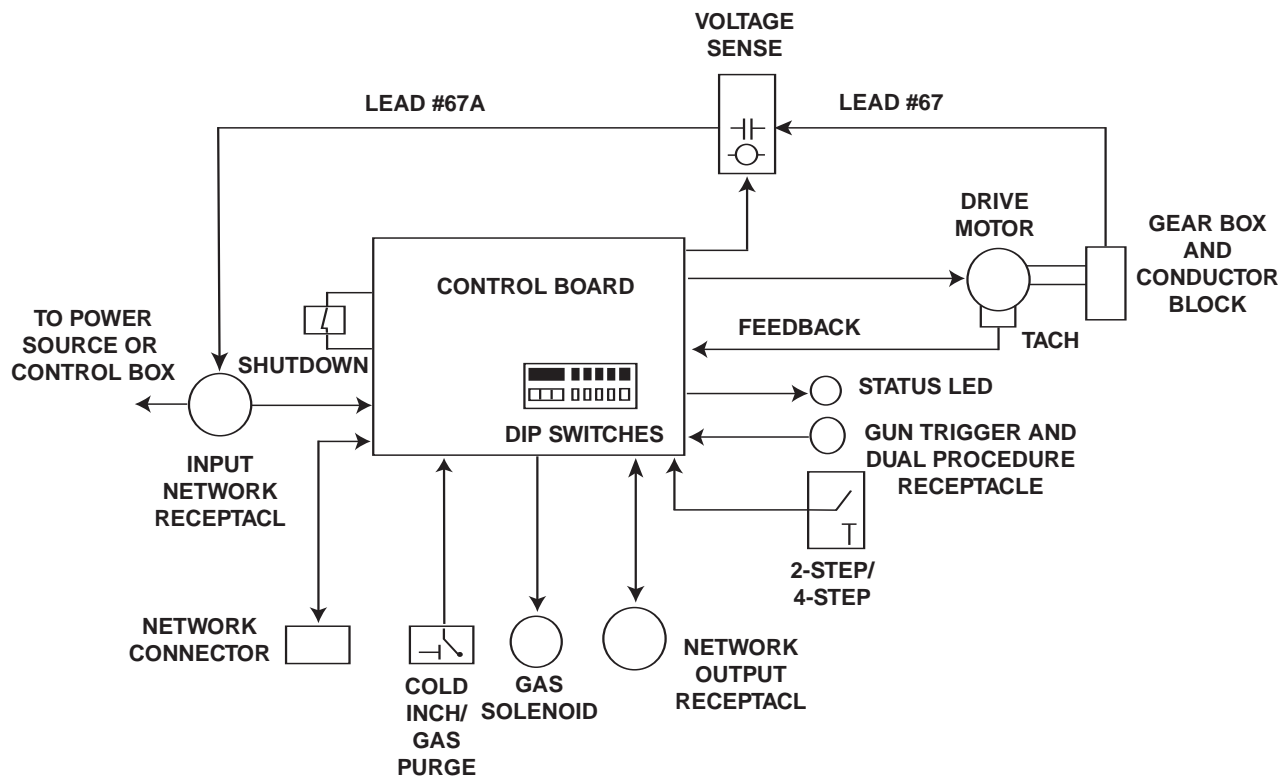

POWER FEED 10M FEED HEAD

The Power Feed 10M is a four roll, high performance, digitally controlled, modular wire feeder that operates on 40 VDC input power. It is designed to be a part of a modular, multi-process welding system. Refer to Figure E.2.

Network communications, intelligence, PC board input power, and arc voltage feedback is received and transmitted through the input network receptacle. The internal network connector plug is utilized when the Control Box is mounted directly to the wire drive unit. See **System Diagram A** in this section.

The feed head drive control board processes the information it receives from the various user operated switches such as the gun trigger, 2-step/4-step, and cold inch switches and sends this information to other system components. This information is evaluated and the correct commands are transmitted to the feed head drive. The feed head drive control board then sends the signals to energize the active components such as the solenoid and wire drive motor. The tach feedback signal is processed on the

control board which regulates the motor armature voltage so as to maintain the required wire feed speed.

When the gun trigger is pulled, the voltage sense board relays the electrode sense signal to the input network receptacle for processing by the Control Box.

The optional shutdown feature can be implemented as a means of stopping the wire feeding in the event that the water cooler (if used) is not turned on.

The STATUS LED is designed to blink a red and green code if a fault should occur.

There is one DIP switch bank located on the wire drive control board. It is labeled S1 and is used to set gear ratios, arc polarity, and for network identification purposes.

POWER FEED 10M SINGLE/DUAL

FIGURE E.3 – CONTROL BOX (User Interface)

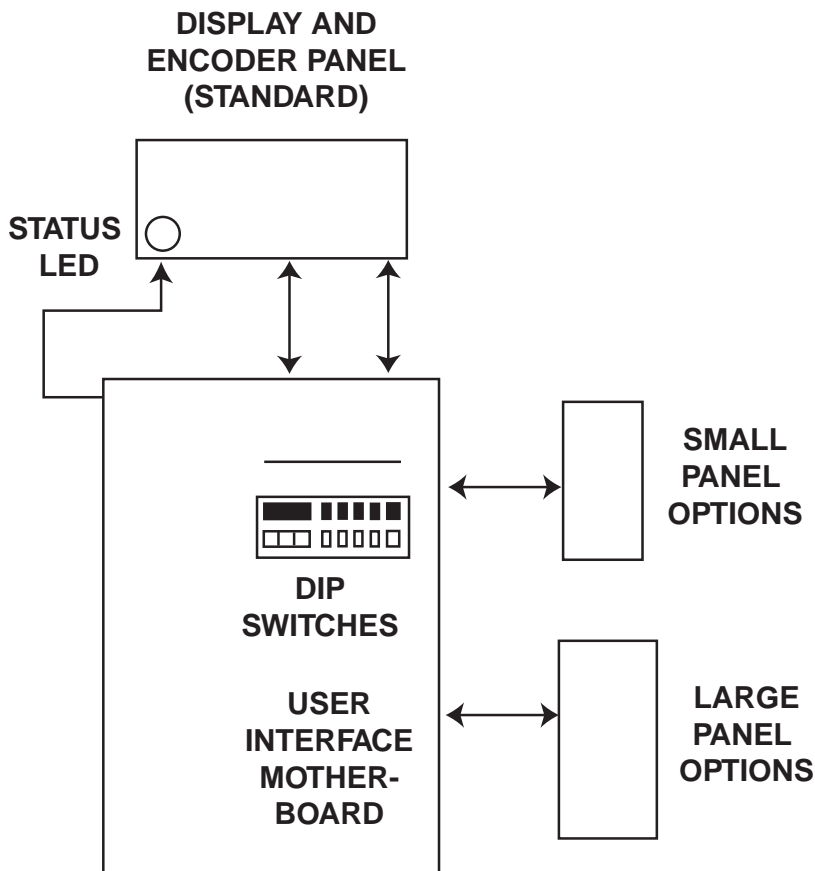

CONTROL BOX (USER INTERFACE)

BOOM MODELS ONLY

The system Control Box is the main entry point for all system parameters, and from it the user can control both power source and wire feeder functions. Refer to figure E.10. The user interface motherboard is the heart of the Control Box. Dependent upon the option panels and the information received through the network cable, it directs the entire system as to the options, wire feed speed, and weld cycle requirements and parameters.

The options are divided into two physical size categories. The smaller option, typically installed in the middle section of the control box, is dedicated to dual procedure, head selection, and memory related functions. The larger, or bottom section, is reserved for control of the setup functions for the power source (Power Wave 455m) and wire drive (Power Feeder 10m) such as mode, arc control, run in and timer set up.

In addition to the large and smaller size options, there is a Display Panel which is standard on the Control Box unit. The Display Panel is typically installed in the upper position of the Control Box assembly and the STATUS LED. The controls are used to adjust the wire feed speed, current, voltage and trim parameters. The STATUS LED is designed to blink a red and green code if a fault should occur.

The PF-10M single bench and the PF-10M dual bench do not have User Interface Boards in the control box. On these models the User Interface Bd circuitry is on the feed head Bd located in the wire drive box.

POWER FEED 10M SINGLE/DUAL



Return to Section TOC
Return to Master TOC
Return to Section TOC
Return to Master TOC
Return to Section TOC
Return to Master TOC
Return to Section TOC
Return to Master TOC

POWER FEED 10M SINGLE/DUAL



TABLE OF CONTENTS

- TROUBLESHOOTING & REPAIR SECTION -

Troubleshooting & Repair SectionSection F

How to Use Troubleshooting Guide.....F-2

PC Board Troubleshooting Procedures and Replacement.....F-3

Test Procedures.....F-17/F-21

 Voltage Sense PC board Test.....F-17

 Tach Feedback Test.....F-19

 Drive Motor TestF-21

Removal and Replacement Procedures.....F-23/F-25

 Gear Box and Drive Motor Removal and Replacement.....F-23

Retest After Repair.....F-26

Return to Master TOC

Return to Master TOC

Return to Master TOC

Return to Master TOC



CAUTION

Service and repair should be performed by only Lincoln Electric Factory Trained Personnel. Unauthorized repairs performed on this equipment may result in danger to the technician and machine operator and will invalidate your factory warranty. For your safety and to avoid Electrical Shock, please observe all safety notes and precautions detailed throughout this manual.

This Troubleshooting Guide is provided to help you locate and repair possible machine malfunctions. Simply follow the three-step procedure listed below.

Step 1. LOCATE PROBLEM (SYMPTOM). Look under the column labeled “PROBLEM (SYMPTOMS)”. This column describes possible symptoms that the machine may exhibit. Find the listing that best describes the symptom that the machine is exhibiting. Symptoms are grouped into three main categories: Feeding Problems and Welding Problems.

Step 2. PERFORM EXTERNAL TESTS. The second column, labeled “POSSIBLE AREAS OF MISADJUSTMENT(S)”, lists the obvious external possibilities that may contribute to the machine symptom. Perform these tests/checks in the order listed. In general, these tests can be conducted without removing the case wrap-around cover.

Step 3. PERFORM COMPONENT TESTS. The last column, labeled “Recommended Course of Action” lists the most likely components that may have failed in your machine. It also specifies the appropriate test procedure to verify that the subject component is either good or bad. If there are a number of possible components, check the components in the order listed to eliminate one possibility at a time until you locate the cause of your problem.

All of the referenced test procedures referred to in the Troubleshooting Guide are described in detail at the end of this chapter. Refer to the Troubleshooting and Repair Table of Contents to locate each specific Test Procedure. All of the referred to test points, components, terminal strips, etc., can be found on the referenced electrical wiring diagrams and schematics. Refer to the Electrical Diagrams Section Table of Contents to locate the appropriate diagram.



CAUTION

If for any reason you do not understand the test procedures or are unable to perform the test/repairs safely, contact the Lincoln Electric Service Department for electrical troubleshooting assistance before you proceed. Call 1-888-935-3877.

POWER FEED 10M SINGLE/DUAL



PC BOARD TROUBLESHOOTING PROCEDURES

! WARNING

**ELECTRIC SHOCK
can kill.**

- Have an electrician install and service this equipment. Turn the input power OFF at the fuse box before working on equipment. Do not touch electrically hot parts.

! CAUTION

Sometimes machine failures appear to be due to PC board failures. These problems can sometimes be traced to poor electrical connections. To avoid problems when troubleshooting and replacing PC boards, please use the following procedure:

1. Determine to the best of your technical ability that the PC board is the most likely component causing the failure symptom.
2. Check for loose connections at the PC board to assure that the PC board is properly connected.
3. If the problem persists, replace the suspect PC board using standard practices to avoid static electrical damage and electrical shock. Read the warning inside the static resistant bag and perform the following procedures:

PC board can be damaged by static electricity.

- Remove your body's static charge before opening the static-shielding bag. Wear an anti-static wrist strap. For safety, use a 1 Meg ohm resistive cord connected to a grounded part of the equipment frame.

- If you don't have a wrist strap, touch an un-painted, grounded, part of the equipment frame. Keep touching the frame to prevent static build-up. Be sure not to touch any electrically live parts at the same time.

- Tools which come in contact with the PC board must be either conductive, anti-static or static-dissipative.

- Remove the PC board from the static-shielding bag and place it directly into the equipment. Don't set the PC board on or near paper, plastic or cloth which could have a static charge. If the PC board can't be installed immediately, put it back in the static-shielding bag.

- If the PC board uses protective shorting jumpers, don't remove them until installation is complete.

- If you return a PC board to The Lincoln Electric Company for credit, it must be in the static-shielding bag. This will prevent further damage and allow proper failure analysis.

4. Test the machine to determine if the failure symptom has been corrected by the replacement PC board.

NOTE: It is desirable to have a spare (known good) PC board available for PC board troubleshooting.

NOTE: Allow the machine to heat up so that all electrical components can reach their operating temperature.

5. Remove the replacement PC board and substitute it with the original PC board to recreate the original problem.
 - a. If the original problem does not reappear by substituting the original board, then the PC board was not the problem. Continue to look for bad connections in the control wiring harness, junction blocks, and terminal strips.
 - b. If the original problem is recreated by the substitution of the original board, then the PC board was the problem. Reinstall the replacement PC board and test the machine.
6. Always indicate that this procedure was followed when warranty reports are to be submitted.

NOTE: Following this procedure and writing on the warranty report, "INSTALLED AND SWITCHED PC BOARDS TO VERIFY PROBLEM," will help avoid denial of legitimate PC board warranty claims.

POWER FEED 10M

Observe Safety Guidelines detailed in the beginning of this manual.

PROBLEMS (SYMPTOMS)	POSSIBLE AREAS OF MISADJUSTMENT(S)	RECOMMENDED COURSE OF ACTION
FUNCTION PROBLEMS		
Major physical or electrical damage is evident when the sheet metal cover(s) are removed.	1. Contact your local authorized Lincoln Electric Field Service Facility for assistance.	1. Contact the Lincoln Electric Service Department, 1-888-935-3877.
No wire feed, solenoid or arc voltage. The STATUS LED's are steady green.	1. The gun trigger may be faulty. Check or replace. 2. Make certain the Control Box is configured for a wire feeding mode. 3. Check option panel connections and switch(s) for proper operation.	1. Check the continuity of leads from the gun trigger receptacle to plug J85. See wire drive wiring diagram. 2. The wire drive feedhead board may be faulty. 3. The Control Box control board
No control of wire feed speed. All STATUS LEDs are steady green. The preset wire feed speed is adjustable on the Control Box.	1. Check for a mechanical restriction in the wire feed path.	1. Perform the Tach Feedback Test . 2. The wire drive feedhead board may be faulty.
No welding arc voltage when the gun trigger is activated. The wire feeds normally and the gas solenoid functions properly. The STATUS LEDs are steady green on the wire drive unit and the Control Box.	1. The Power source may be unable to produce welding output due to a thermal fault or other malfunction. Check STATUS LED on Power Wave 455 machine. See Power Wave 455 Troubleshooting .	1. Make certain the Power Wave 455M power source is functioning correctly. 2. The wire drive feedhead board may be faulty. 3. The Control Box control board may be faulty.
The wire feed speed does not change when welding current is established. The WFS stays at the run-in speed. The STATUS LEDs are steady green.	1. The run in and weld wire feed speeds may be set to the same value. Set run in speed to a value that gives best starting results.	1. Perform the Current Transducer Test . In Power Wave 455 service manual. 2. If the run in wire feed speed cannot be adjusted, perform the Tach Feedback Test and also the Drive Motor Test . 3. The wire drive feedhead board may be faulty.

**CAUTION**

If for any reason you do not understand the test procedures or are unable to perform the test/repairs safely, contact the Lincoln Electric Service Department at 1-888-935-3877 for electrical troubleshooting assistance before you proceed.

POWER FEED 10M SINGLE/DUAL

POWER FEED 10M

Observe Safety Guidelines detailed in the beginning of this manual.

PROBLEMS (SYMPTOMS)	POSSIBLE AREAS OF MISADJUSTMENT(S)	RECOMMENDED COURSE OF ACTION
FUNCTION PROBLEMS (Continued)		
<p>The purge switch on the wire drive unit does not activate the gas solenoid, but gun trigger closure in the MIG or pulse modes does activate the solenoid. The LEDs are steady green on the power source, Control Box and wire drive unit.</p>	<ol style="list-style-type: none"> 1. Make certain the COLD INCH/GAS PURGE switch is operating properly. 2. Check for loose or faulty leads between COLD INCH/GAS PURGE switch and the wire drive control board. See wiring diagram. 	<ol style="list-style-type: none"> 1. If the COLD INCH/GAS PURGE switch is operating correctly and the associated leads are OK. The feedhead board may be faulty.
<p>The COLD INCH/GAS PURGE switch does not turn on the wire drive motor but gun trigger closure in the MIG or Pulse modes does activate the wire drive motor. The LEDs are steady green on the power source, Control Box and wire drive unit.</p>	<ol style="list-style-type: none"> 1. Make certain the COLD INCH/GAS PURGE switch is operating properly. 2. Check for loose or faulty leads between the COLD INCH/GAS PURGE switch and the wire drive control board. See wiring diagram. 	<ol style="list-style-type: none"> 1. If the COLD INCH/GAS PURGE switch is operating correctly and the associated leads are OK. The feedhead board may be faulty.
<p>The voltmeter on the Control Box does not function properly even though the STATUS LEDS are steady green.</p>	<ol style="list-style-type: none"> 1. Make sure the DIP switches are configured correctly for the welding polarity being used. See Setting Dip Switches in the Wire Drive in the Installation section of this manual. 2. Check the #67 lead on the wire drive unit. Make sure it is connected to the motor gear box and also the voltage sense PC board. 3. Check the work sensing leads on the Power Wave 455 power source. Check leads #202 (Neg. output terminal) and #206 (pos. output terminal). See Power Wave 455 wiring diagram. If external voltage sensing is utilized, Check the #21 lead between the 4-pin receptacle on the front of the Power Wave 455 and the workplace. 	<ol style="list-style-type: none"> 1. Check leads #513 and #514 from J85 on the feedhead board to the voltage sense PC board. 2. Perform the Voltage Sense Board Test. 3. The display board may be faulty. 4. The feedhead control board may be faulty. 5. The Control Box control board may be faulty.

 **CAUTION**

If for any reason you do not understand the test procedures or are unable to perform the test/repairs safely, contact the Lincoln Electric Service Department at 1-888-935-3877 for electrical troubleshooting assistance before you proceed.

POWER FEED 10M SINGLE/DUAL



Return to Section TOC

Return to Section TOC

Return to Section TOC

Return to Section TOC

Return to Master TOC

Return to Master TOC

Return to Master TOC

Return to Master TOC

POWER FEED 10M

Observe Safety Guidelines detailed in the beginning of this manual.

PROBLEMS (SYMPTOMS)	POSSIBLE AREAS OF MISADJUSTMENT(S)	RECOMMENDED COURSE OF ACTION
FUNCTION PROBLEMS (Continued)		
<p>The ammeter on the Control Box does not function properly even though the STATUS LEDs are steady green.</p>	<ol style="list-style-type: none"> 1. Make sure the DIP switches are configured correctly for the welding process and polarity used. See Setting DIP Switches in the Wire Drive in the Installation section of this manual. 2. Check the following connections on the Power Wave 455 machine. Check for loose or faulty connections between plug J90 at the current transducer and plug J21 on the Power Wave 455 control board. 	<ol style="list-style-type: none"> 1. Perform the Current Transducer Test. Power Wave 455 Service Manual. 2. The control board, located in the power source, may be faulty.
<p>The display and/or indicator LEDs do not change when their corresponding switches and or knobs are activated or turned.</p>	<ol style="list-style-type: none"> 1. Check for loose or faulty connections between the encoder panel and the Control Box control board. 2. Check for loose or faulty connections between the appropriate switches and the Control Box control board. 	<ol style="list-style-type: none"> 1. Check suspected potentiometer and/or switches for correct resistances and operation. 2. Refer to machine schematics for lead numbers and voltages. 3. The Control Box control board may be faulty.
<p>The mode and/or settings change while welding under normal conditions.</p>	<ol style="list-style-type: none"> 1. Contact the Lincoln Electric service dept. for possible software updates. (Please ref. your current software number.) 	
<p>The feeder resets when the gun trigger is activated. The LEDs blink and the displays are intermittent.</p>	<ol style="list-style-type: none"> 1. The auxiliary reconnect (Lead "A") may not be configured correctly. See Figure A.2 in the installation Section of this manual. 	<ol style="list-style-type: none"> 1. Perform the Power Board Test. Powerwave service manual. 2. Perform the Auxiliary Transformer Test #1. Powerwave Service Manual.



If for any reason you do not understand the test procedures or are unable to perform the test/repairs safely, contact the Lincoln Electric Service Department at 1-888-935-3877 for electrical troubleshooting assistance before you proceed.

POWER FEED 10M SINGLE/DUAL



Return to Section TOC

Return to Master TOC

POWER FEED 10M

Observe Safety Guidelines detailed in the beginning of this manual.

PROBLEMS (SYMPTOMS)	POSSIBLE AREAS OF MISADJUSTMENT(S)	RECOMMENDED COURSE OF ACTION
FUNCTION PROBLEMS (Continued)		
<p>The displays are blank (not lit). The wire feeds when the gun trigger is activated.</p>	<p>1. Check for loose or faulty connections at plug on the display board, to plug on the feedhead control board.</p>	<p>1. Check for 5VDC at J37 pins 2 and 10 on the display board. If 5 VDC is present, then the display board may be faulty.</p> <p>2. If the 5VDC is low or not present, check for loose or faulty connections in SPI circuit. See machine schematic.</p> <p>3. The feedhead control board may be faulty.</p>
<p>The dual procedure is not functional when using the remote Dual Procedure switch. The STATUS LEDs are steady green on the power source, Control Box and wire drive units.</p>	<p>1. Make certain the LED indicator on the Dual Procedure Panel is in the middle position. This enables the gun remote dual procedure switch.</p>	<p>1. Check shielded cable lead and connections from J86 on PC BD to MSP panel. Check SPI cable from MSP panel to Dual/memory panel. Per machine schematic.</p> <p>2. Check for 5VDC at J86 pins 2 and 10. Check for 15VDC at J86 pins 1 and 10. If voltage is not present replace feed head or user interface BD depending on model. If leads and voltages are good replace dual/memory panel.</p>

 **CAUTION**

If for any reason you do not understand the test procedures or are unable to perform the test/repairs safely, contact the Lincoln Electric Service Department at 1-888-935-3877 for electrical troubleshooting assistance before you proceed.

POWER FEED 10M SINGLE/DUAL



Return to Section TOC
Return to Master TOC

POWER FEED 10M

Observe Safety Guidelines detailed in the beginning of this manual.

PROBLEMS (SYMPTOMS)	POSSIBLE AREAS OF MISADJUSTMENT(S)	RECOMMENDED COURSE OF ACTION
FUNCTION PROBLEMS (Continued)		
The wire feed speed is consistent and adjustable, but runs at the wrong speed.	1. The DIP switch on the wire drive unit may not be set for the correct gear ratio. See the Installation section of this manual.	1. The feed head control board may be faulty.
The unit shuts off while welding or attempting to weld. The STATUS LED is alternating between red and green every second. The unit tries to recover after 30 seconds and may repeat sequence.	1. The shut down circuit in the wire drive unit may be electrically "open". Make sure leads 570A & 570B are connected together. 2. The drive motor may be overloaded due to a mechanical restriction in the wire feeding path. See Operation section of this manual.	1. Disconnect any shutdown device from leads #570A and #570B (0.25 in. insulated tab terminals). Connect leads #570A and #570B together. If the feeder STATUS LED is now steady green, the problem is in the external shutdown circuit. 2. If there are no restrictions in the wire feeding path, the drive motor or gear box may be faulty. 3. The feed head control board may be faulty.

 **CAUTION**

If for any reason you do not understand the test procedures or are unable to perform the test/repairs safely, contact the Lincoln Electric Service Department at 1-888-935-3877 for electrical troubleshooting assistance before you proceed.

POWER FEED 10M SINGLE/DUAL



Return to Section TOC
Return to Master TOC

POWERFEED 10M

Observe Safety Guidelines detailed in the beginning of this manual.

PROBLEMS (SYMPTOMS)	POSSIBLE AREAS OF MISADJUSTMENT(S)	RECOMMENDED COURSE OF ACTION
FUNCTION PROBLEMS (Continued)		
When the gun trigger is activated, the drive rolls do not turn. The arc voltage is present and the solenoid is energized. The STATUS LEDs are steady green.	<ol style="list-style-type: none"> 1. Check plug J83 on the wire drive control board, and leads #550 and #551 for loose or faulty connections. See wiring diagram. 	<ol style="list-style-type: none"> 1. Perform the <i>Drive Motor Test</i>. 2. The feedhead control board may be faulty.
The wire is feeding rough or not feeding, but the drive rolls are turning.	<ol style="list-style-type: none"> 1. The drive roll pressure may be incorrect. Set drive roll pressure. See <i>Operation</i> section of this manual. 2. Check for dirty or rusty electrode wire. 3. Make sure the drive rolls and wire guides are positioned and installed correctly. See <i>Operation</i> section of this manual. 4. Check for mechanical restrictions in the wire feeding path. 	<ol style="list-style-type: none"> 1. Contact the Lincoln Electric Service Department at 1.888.935.3877
When in CC modes with the optional "MX" or "MXP" panels, the output does not energize.	<ol style="list-style-type: none"> 1. Rotate Volts/Trim encoder knob at least 45 degrees clockwise. This is normal. See <i>Accessories</i> section for detailed operation. 	<ol style="list-style-type: none"> 1. Check option panel installation for loose or faulty connections.

 **CAUTION**

If for any reason you do not understand the test procedures or are unable to perform the test/repairs safely, contact the Lincoln Electric Service Department at 1-888-935-3877 for electrical troubleshooting assistance before you proceed.

POWER FEED 10M SINGLE/DUAL



Return to Section TOC

Return to Section TOC

Return to Section TOC

Return to Section TOC

Return to Master TOC

Return to Master TOC

Return to Master TOC

Return to Master TOC

POWERFEED 10M

Observe Safety Guidelines detailed in the beginning of this manual.

PROBLEMS (SYMPTOMS)	POSSIBLE AREAS OF MISADJUSTMENT(S)	RECOMMENDED COURSE OF ACTION
WELDING PROBLEMS		
The gun tip seizes in diffuser.	<ol style="list-style-type: none"> 1. The tip may be overheating due to prolonged or excessive high current and /or duty cycle. Do not exceed the current and duty cycle rating of the gun. 2. A light application of high temperature anti-seize lubricant (such as Graphite Grease) may be applied to tip threads. 	<ol style="list-style-type: none"> 1. Contact the Lincoln Electric Service Department at 1.888.935.3877
Poor arc striking with sticking or "blast-offs". The weld bead may be narrow and ropy with weld porosity.	<ol style="list-style-type: none"> 1. Make sure the weld procedures are correct for the process being used. Check gas, wire feed, speed and arc voltage. 2. Remove the gun liner and check the rubber seal for any sign of deterioration or damage. Be sure the set screw in the connector block is in place and tightened against the liner bushing. 3. Check the welding cables for loose or faulty connections. 	<ol style="list-style-type: none"> 1. Contact the Lincoln Electric Service Department at 1.888.935.3877
The arc is variable and/or hunting. The power source, Control Box and drive units seem to be operating properly.	<ol style="list-style-type: none"> 1. Check the contact tip. It may be worn or the wrong size for the electrode wire being used. 2. Check for loose or faulty welding cables and connections. 3. Make sure the procedures are correct for the process being used. Check gas, wire feed speed and arc voltage. 	<ol style="list-style-type: none"> 1. Contact the Lincoln Electric Service Department at 1.888.935.3877

 **CAUTION**

If for any reason you do not understand the test procedures or are unable to perform the test/repairs safely, contact the Lincoln Electric Service Department at 1-888-935-3877 for electrical troubleshooting assistance before you proceed.

POWER FEED 10M SINGLE/DUAL



Return to Section TOC

Return to Master TOC

Observe all Safety Guidelines detailed throughout this manual

Error Codes for the Power Wave 455: Code 10555 and below

Note: For any Err # listed below write down the error number for reference and try cycling power to see if the error clears itself. If not, refer to the What to Do column for the given Err.

PROBLEMS (SYMPTOMS)	POSSIBLE CAUSE	RECOMMENDED COURSE OF ACTION
Display shows any of the following:		
Err 001	More than 1 CB with the same group number.	Make sure the group dip switch setting is unique for each CB.
Err 003	Too many objects in group.	A given group can only support up to 7 objects. Remove any objects over 7 from the group either by changing the group dip switch settings or physically disconnecting any objects over 7 in the group.
Err 004	More than 1 object of the same equipment type with the same group # and feed head #.	Adjust the dip switch setting to make either the group # or feed head # unique for all objects of the same equipment type.
Err 005	A feed head has its feed head dip switches set to zero in a group with more than one object.	The appropriate feed head # is 1 through 7. Check the dip switch setting chart in INSTALLATION section and set the switches to make the Feed head ID non-zero.
Err 006	Did not receive a recognition command from the power source.	Check to see if the status light is <u>not</u> solid green on the power source (refer to status light states in OPERATION section if not). Also, check continuity in the communication lines from CB to Power Source (refer to wiring diagram). Refer to Power source trouble shooting section for additional information. If all these avenues fail, replace CB mother PC board.

CAUTION

If for any reason you do not understand the test procedures or are unable to perform the test/repairs safely, contact the Lincoln Electric Service Department at 1-888-935-3877 for electrical troubleshooting assistance before you proceed.

POWER FEED 10M SINGLE/DUAL



Observe all Safety Guidelines detailed throughout this manual

Error Codes for the Power Wave 455: Code 10555 and below

Note: For any Err # listed below write down the error number for reference and try cycling power to see if the error clears itself. If not, refer to the What to Do column for the given Err.

PROBLEMS (SYMPTOMS)	POSSIBLE CAUSE	RECOMMENDED COURSE OF ACTION
Display shows any of the following:		
Err 020	An attempt was made to reprogram a CB or feed head but the program did not verify.	Check for potential electrical HF noise generators in the area. Try removing the noise source and programming again. If the Err 020 still occurs, either replace the EEPROM chip(s) in the board being reprogrammed or replace the whole PC board being reprogrammed.
Err 100	The Power Source issued a shut down command for some reason.	See what to Do on Err 006.
Err 200	No Heart beat response from the PS.	See what to Do on Err 006.
Err 201	No heart beat response from an object.	If this occurs while welding, the status LED should be flashing red on the object that lost heart beat. Otherwise, look for any nodes that are flashing green. This indicates they have not been recognized and there is a power source problem (see power source trouble shooting section). If the status LED is either flashing or solid red, there may be a problem with continuity in the communication lines. Check the lines for continuity, in the cable and harnessing (refer to wiring diagram).
Err 210	EEPROM error.	Parameter recalled at power up was out of range. Rotate Encoder Knob to reset. Check all settings before proceeding to weld. If this condition persists then replace the CB mother PC board.

CAUTION

If for any reason you do not understand the test procedures or are unable to perform the test/repairs safely, contact the Lincoln Electric Service Department at 1-888-935-3877 for electrical troubleshooting assistance before you proceed.

POWER FEED 10M SINGLE/DUAL



Observe all Safety Guidelines detailed throughout this manual

Error Codes for the Power Wave 455: Code 10555 and below

Note: For any Err # listed below write down the error number for reference and try cycling power to see if the error clears itself. If not, refer to the What to Do column for the given Err.

PROBLEMS (SYMPTOMS)	POSSIBLE CAUSE	RECOMMENDED COURSE OF ACTION
Display shows any of the following:		
Err 211	Microprocessor RAM error in Control Box.	Turn Power off at power source. Wait 5 seconds. Turn power back on. If Err 211 is displayed again, then replace CB mother PC board.
Err 212	Microprocessor RAM Error in object board other than Control Box (Such as feed head)	Cycle power as in Err 211. If Err 212 is still displayed, then replace the PC board in the object with the fault. The object with the fault should be solid red on its status LED.
- - - (three dashes)	Appears on right display of CB module that contains the status LED	This is an indication that a constant current such as stick or gauge mode has been selected. Turning the right encoder clockwise when in this state will activate output to Power Source. Turning the right encoder counter-clockwise will deactivate output.

⚠ CAUTION

If for any reason you do not understand the test procedures or are unable to perform the test/repairs safely, contact the Lincoln Electric Service Department at 1-888-935-3877 for electrical troubleshooting assistance before you proceed.

POWER FEED 10M SINGLE/DUAL



Return to Section TOC

Return to Master TOC

Return to Section TOC

Return to Master TOC

Return to Section TOC

Return to Master TOC

Observe all Safety Guidelines detailed throughout this manual

PROBLEMS (SYMPTOMS)	POSSIBLE CAUSE	RECOMMENDED COURSE OF ACTION
OUTPUT PROBLEMS		
The feeder doesn't power up - no display, no cold feed.	<ol style="list-style-type: none"> 1. The Power Feed 10M Single Wire Feeder power switch is OFF. Turn the Power Feed 10M Single Wire Feeder power switch ON. 2. The Power Wave power source is OFF. Turn ON the Power Wave power source. 3. The circuit breaker for the wire feeder on power source have tripped. Reset the circuit breakers. 4. The control cable may be loose or damaged. Tighten, repair or replace the control cable. 5. The power switch is damaged. Replace the power switch. 	<ol style="list-style-type: none"> 1. Check for 40VDC at J81 leads #540 and #500. If voltage is present, replace P.C. BD. If voltage not present, check leads from J81 on BD. to Input 5 pin connector. Refer to machine schematic.
No shielding gas.	<ol style="list-style-type: none"> 1. The gas supply is OFF or empty. Verify the gas supply is ON and flowing. 2. The gas hose is cut or crushed. Route the gas hose so it avoids sharp corners and make sure nothing is on top of it. Repair or replace damaged hoses. 3. Dirt or debris is in the solenoid. Apply filtered shop at 80psi to the solenoid to remove dirt. 4. There is a loose solenoid connection. Remove the cover and check that all connections are in good condition. 5. The solenoid has failed. 	<ol style="list-style-type: none"> 1. Check for 6.5VDC with trigger pulled at J83 leads #553 and #554. If voltage is present replace solenoid. If voltage is not present replace P.C. BD. Refer to machine schematic.

⚠ CAUTION

If for any reason you do not understand the test procedures or are unable to perform the test/repairs safely, contact the Lincoln Electric Service Department at 1-888-935-3877 for electrical troubleshooting assistance before you proceed.

POWER FEED 10M SINGLE/DUAL



Return to Section TOC
Return to Master TOC

Observe all Safety Guidelines detailed throughout this manual

PROBLEMS (SYMPTOMS)		POSSIBLE CAUSE	RECOMMENDED COURSE OF ACTION
ARCLINK SYSTEM ERROR CODES			
Err 44	Main CPU problem.	<ol style="list-style-type: none"> 1. Verify the ground connection to the power source is wired correctly. 2. See the power source service Manual. 	<ol style="list-style-type: none"> 1. The main processor in the system did not respond to another processor within the allotted time. Reflash system with latest software. Replace circuit board.
Err 53	Voltage sense loss.	<ol style="list-style-type: none"> 1. The system detected that one of the voltage sense lead cables was disconnected from the welding circuit during a weld. 	<p>Verify that leads 67 and 21 is enabled and connected. See enhanced schematic.</p>
Err 81	Motor overload, long term.	<ol style="list-style-type: none"> 1. The wire drive motor has overheated. Check that the electrode slides easily through the gun and cable. 	<ol style="list-style-type: none"> 2. Remove tight bends from the gun and cable. 3. Check that the spindle brake is not too tight. 4. Verify a high quality electrode is being used. 5. Wait for the error to reset and the motor to cool (approximately 1 minute).
Err 82	Motor overload, short term.	<ol style="list-style-type: none"> 1. The wire drive motor current draw has exceeded limits, usually because the motor is in a locked rotor state. Check that motor can turn freely when idle arm is open. 	<ol style="list-style-type: none"> 2. Verify that the gears are free of debris and dirt.
Err 95	Spool gun or pull gun motor overload.	<ol style="list-style-type: none"> 1. The drive motor in the spool gun or push-pull gun is drawing too much current. 	<p>Check spool gun brake or feeding for binding. Replace spool gun circuit board.</p>
Err 263	No usable weld modes.	<ol style="list-style-type: none"> 1. The power source does not have any welding programs loaded. Required configuration could not be found. 	<p>Make sure the status of all devices is conected correctly to the machine. Reflash system software.</p>

CAUTION

If for any reason you do not understand the test procedures or are unable to perform the test/repairs safely, contact the Lincoln Electric Service Department at 1-888-935-3877 for electrical troubleshooting assistance before you proceed.

POWER FEED 10M SINGLE/DUAL



Return to Section TOC
Return to Master TOC
Return to Section TOC
Return to Master TOC
Return to Section TOC
Return to Master TOC
Return to Section TOC
Return to Master TOC

POWER FEED 10M SINGLE/DUAL



VOLTAGE SENSE PC BOARD TEST

**WARNING**

Service and repair should be performed by only Lincoln Electric factory trained personnel. Unauthorized repairs performed on this equipment may result in danger to the technician or machine operator and will invalidate your factory warranty. For your safety and to avoid electrical shock, please observe all safety notes and precautions detailed throughout this manual.

If for any reason you do not understand the test procedures or are unable to perform the test / repairs safely, contact the Lincoln Electric Service Department for electrical troubleshooting assistance before you proceed. Call 1-888-935-3877.

TEST DESCRIPTION

This test will help determine if the voltage sensing board is receiving the correct activation signal from the control board and also if the voltage sensing board is processing arc voltage sensing information.

MATERIALS NEEDED

3/8 in. nut driver
Volt-Ohm Meter

VOLTAGE SENSE PC BOARD TEST *(continued)*

FIGURE F.1 – VOLTAGE SENSING BOARD TEST

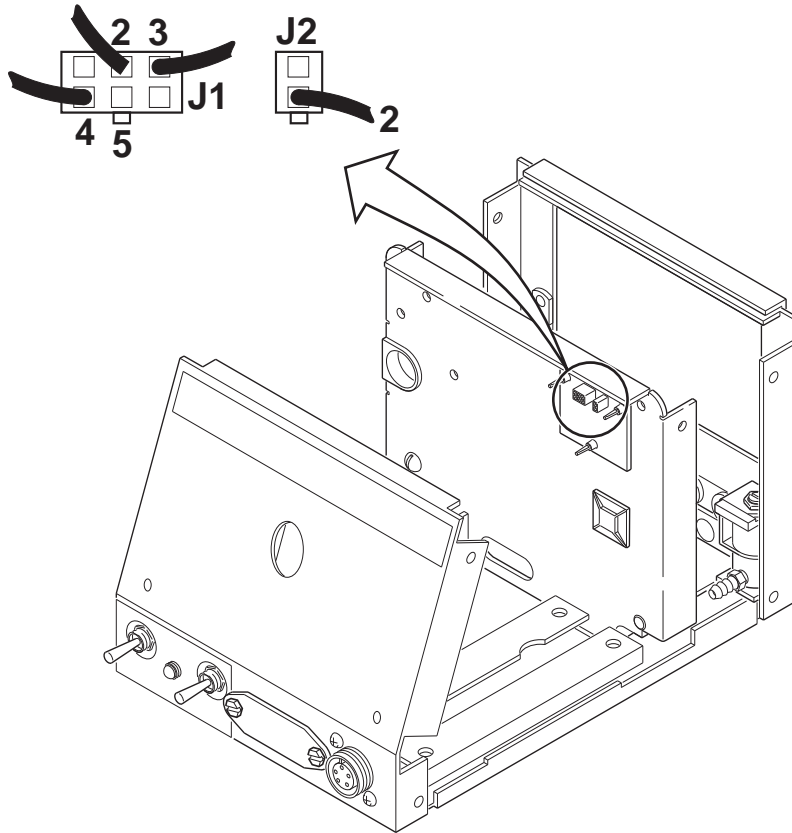

NOTE: Inspect the molex plug connector pins on the Voltage Sense Board. If any of them are gold plated the P.C. board should be replaced.

TEST PROCEDURE

1. Remove input power from the wire feed unit.
2. Using the 3/8 in. nut driver, remove the cover from the wire feeder.
3. Locate the voltage sense PC board and plugs J1 and J2. Do not remove the plugs from the voltage sense pc board. Refer to **Figure F.1**.
4. Apply the correct input power (from the Power Wave 455 control cable) to the wire feeder. With the gun trigger activated, check for approximately 12 VDC at plug J1 pin 1 (+) to pin 4 (-). If the 12 VDC is NOT present, the feedhead board may be faulty. Also check for loose or faulty wires and connections between the feedhead board (plug J85 and plug J1 on the voltage sense PC board).
5. With the gun trigger activated and arc voltage present at the conductor block, check for arc voltage from plug J1 pin 3 (lead 67) to the workpiece. If actual arc voltage is NOT present, check the continuity of lead 67 from the conductor block to plug J1 pin 3 on the voltage sense PC board.
6. If the actual arc voltage IS present at plug J1 pin 3 (lead 67), then check for arc voltage from plug J2 pin 2 (lead 67B) to the workpiece. See wiring diagram.
7. If the 12 VDC IS present in step #4 and the arc voltage IS present in step #5 but the arc voltage is NOT present in step #6 (lead 67A), the voltage sense PC board may be faulty.
8. Remove all input power from the wire feeder unit.
9. Install the wire feeder cover with the 3/8 in. nut driver.

POWER FEED 10M SINGLE/DUAL



TACH FEEDBACK TEST



WARNING

Service and repair should be performed by only Lincoln Electric factory trained personnel. Unauthorized repairs performed on this equipment may result in danger to the technician or machine operator and will invalidate your factory warranty. For your safety and to avoid electrical shock, please observe all safety notes and precautions detailed throughout this manual.

If for any reason you do not understand the test procedures or are unable to perform the test / repairs safely, contact the Lincoln Electric Service Department for electrical troubleshooting assistance before you proceed. Call 1-888-935-3877.

TEST DESCRIPTION

This test will determine if the tach unit is receiving the correct supply voltage from the control board, and also if the tach unit is sending feedback information to the control board.

MATERIALS NEEDED

3/8 in. nut driver
Volt-Ohmmeter

TACH FEEDBACK TEST

(continued)

FIGURE F.2 – TACH FEEDBACK TEST.

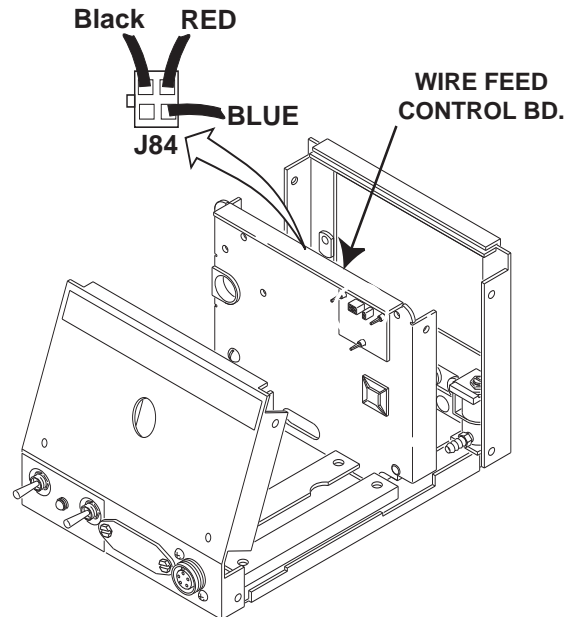

TEST PROCEDURE

1. Remove input power from the wire feeder unit.
2. Using the 3/8 in. nut driver, remove the cover from the wire feeder.
3. Locate plug J84 on the feedhead board. Refer to **Figure F.2**. Do NOT remove the plug from the feedhead board.
4. Apply the correct input power (from the Power Wave 455 control cable) to the wire feeder unit and check for approximately 5VDC from (red wire) positive to (black wire) negative. This is the supply voltage from feedhead board to the tach feedback unit. If the 5VDC is missing or not correct, the feedhead board may be faulty. Also check for loose or faulty wires and connections.
5. With the gun trigger activated and the motor running, check the feedback voltage at plug J84 (blue wire) positive to (black wire) negative. Normal feedback voltage is approximately 2 VDC. If the correct supply voltage is present and the feedback voltage is missing, the tach unit may be faulty. With the motor NOT running, the feedback voltage may be either 0 or 2 VDC depending upon where the motor stopped.
6. Remove input power from the wire feeder unit.
7. Install the wire feeder cover with the 3/8 in. nut driver.

POWER FEED 10M SINGLE/DUAL



DRIVE MOTOR TEST

**WARNING**

Service and repair should be performed by only Lincoln Electric factory trained personnel. Unauthorized repairs performed on this equipment may result in danger to the technician or machine operator and will invalidate your factory warranty. For your safety and to avoid electrical shock, please observe all safety notes and precautions detailed throughout this manual.

If for any reason you do not understand the test procedures or are unable to perform the test / repairs safely, contact the Lincoln Electric Service Department for electrical troubleshooting assistance before you proceed. Call 1-888-935-3877.

TEST DESCRIPTION

This test will determine if the wire drive motor is recovering the correct voltage, and if it is capable of running properly.

MATERIALS NEEDED

3/8 in. nut driver
Volt-Ohmmeter

DRIVE MOTOR TEST (continued)

FIGURE F.3 – DRIVE MOTOR TEST

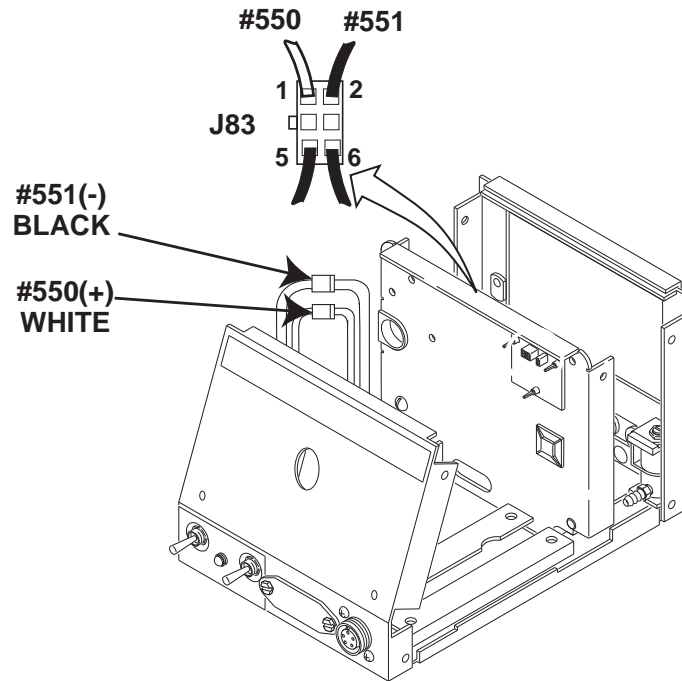

PROCEDURE

1. Remove input power to wire feed unit.
2. Using the 3/8 in. nut driver, remove the cover from the wire feeder.
3. Locate the two quick connectors in the two motor armature leads. Refer to **Figure F.3**. Do NOT disconnect the leads.
4. Apply the correct input power (from the Power Wave 455 control cable) to the wire feeder. Activate the gun trigger and with the motor running check at the quick connectors [#550 White (+) to #551 / Black (-)] for approximately 1 VDC to 32 VDC dependent upon motor speed. The motor speed should vary with changes in motor armature voltage.
5. If the correct voltages are NOT present at the motor leads, check the associated leads between the motor and plug J83 on the feedhead board. If the leads are OK, the feedhead board may be faulty.
6. If the correct voltages are present at motor armature leads and the motor does not run and vary speed with changes in armature voltage, the motor or gear box may be faulty. See **Gear Box and Drive Motor Removal and Replacement**.
7. Install the wire feeder cover using the 3/8 in. nut driver.

POWER FEED 10M SINGLE/DUAL



GEAR BOX AND DRIVE MOTOR REMOVAL AND REPLACEMENT**WARNING**

Service and repair should be performed by only Lincoln Electric factory trained personnel. Unauthorized repairs performed on this equipment may result in danger to the technician or machine operator and will invalidate your factory warranty. For your safety and to avoid electrical shock, please observe all safety notes and precautions detailed throughout this manual.

If for any reason you do not understand the test procedures or are unable to perform the test / repairs safely, contact the Lincoln Electric Service Department for electrical troubleshooting assistance before you proceed. Call 1-888-935-3877.

TEST DESCRIPTION

This test will aid the technician in the removal and replacement of the wire feed drive motor.

MATERIALS NEEDED

3/8 in. nut driver
Slot head screwdriver
Phillips head screwdriver
7/16 in. socket wrench with extension
Needlenose pliers
5/16 in. wrench
3/16 in. Allen wrench

POWER FEED 10M SINGLE/DUAL

GEAR BOX AND DRIVE MOTOR REMOVAL AND REPLACEMENT

Figure F.4- GEAR BOX AND DRIVE MOTOR REMOVAL AND REPLACEMENT

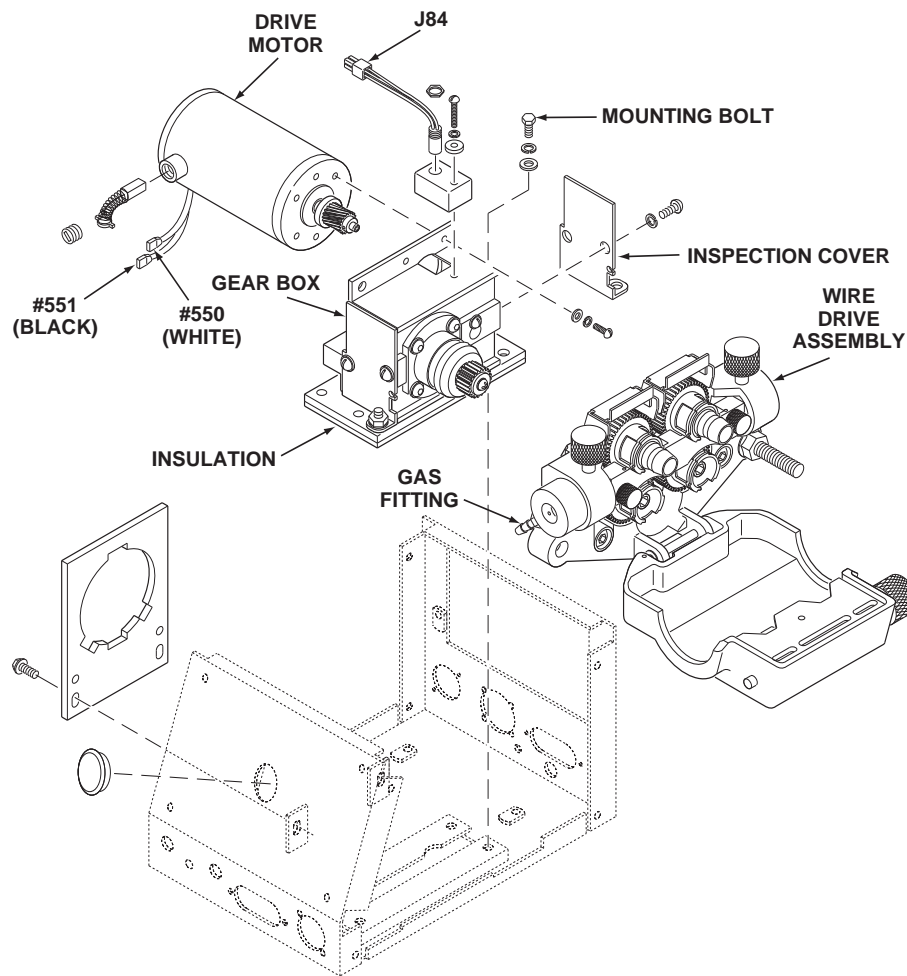
**TEST PROCEDURE**

1. Remove the input power to the wire drive unit.
2. Using the 3/8 in. nutdriver, remove the case cover.
3. Locate and remove plug J84 from the control board. Refer to figure F.4.
4. Thread plug J84 and associated leads through the vertical baffle. Cut any necessary cable ties.
5. Locate and disconnect the motor leads (#551 and #550) at the quick connects. Cut any necessary cable ties.
6. Using the Phillips head screwdriver, remove the #67 lead from the conductor block.
7. Using the needlenose pliers, disconnect the gas hose from the brass gun connector block.
8. Using the 7/16 in. socket wrench, remove the four mounting bolts, lock washers, and flat washers from the plastic base insulator.
9. Carefully slide and remove the entire gear box, drive motor, and wire drive assembly from the wire feeder case. Note insulation placement for reassembly.

POWER FEED 10M SINGLE/DUAL

GEAR BOX AND DRIVE MOTOR REMOVAL AND REPLACEMENT

TO REMOVE THE DRIVE MOTOR FROM THE GEAR BOX:

10. Using the slot head screwdriver, remove the gear box inspection cover nearest to the drive motor.
11. Using the 5/16 in. wrench, remove the motor mounting screw located inside the gear box.
12. Using the slot head screwdriver, remove the two screws mounting the "top" of the motor to the gear box.
13. Carefully remove the motor from the gear box assembly. Note motor lead placement for reassembly.

TO REMOVE THE WIRE DRIVE ASSEMBLY FROM THE GEAR BOX:

14. Using the 3/16 in. Allen wrench, loosen the two Allen type screws at the bottom of the wire drive unit.
15. Remove lead #67 from the conductor block.
16. Carefully slide and remove the wire drive assembly from the gear box assembly.

REPLACEMENT PROCEDURES

1. Carefully slide the wire drive assembly and gear box together.
2. Tighten the two Allen type screws at the bottom of the wire drive unit using the 3/16 in. Allen wrench.
3. Attach lead #67 to the conductor block.
4. Carefully slide the drive motor into the gear box assembly. Be sure to position the motor leads so that they can be properly connected.

5. Install the slot head screws that mount the "top" of the drive motor to the gear box.
6. Install the mounting screw located inside the gearbox using the 5/16 in. wrench.
7. Install the gear box inspection cover and secure it with slot head screws.
8. Properly place insulation in the bottom of the wire feeder case.
9. Place the entire gear box, drive motor and wire drive assembly into the wire feeder case, aligning the holes in the plastic base insulator with the mounting holes in the case.

10. Mount the gear box and drive motor assembly to the wire feeder case using the four mounting bolts, lock washers and flat washers.
11. Connect the gas hose to the brass gun connector block.
12. Connect drive motor leads #550 and #551 to their quick disconnects.
13. Thread plug J4 and associated leads through the vertical baffle and attach it to the control board. Install cable ties as necessary.
14. Install the wire feeder cover using the 3/8 in. nut driver.

RETEST AFTER REPAIR

Retest a machine:

- If it is rejected under test for any reason that requires you to remove any part which could affect the machine's electrical characteristics.

OR

- If you repair or replace any electrical components.

SET UP

1. Once the repairs have been completed, the feeder must be connected to a Powerwave 455M power source.
2. Go to the Service Navigator under Diagnostic Utility and perform the calibration procedure.
3. With the use of a load bank and the utility, all functions of the feeder can be tested.

TABLE OF CONTENTS - ELECTRICAL DIAGRAMS SECTION -

Electrical Diagrams.....Section G

Wiring Diagram - Entire Machine - Code 10962, 11194 - (G4319-1).....G-2

Wiring Diagram - Entire Machine - Code 11086, 11216 - (G4439).....G-3

Wiring Diagram - Entire Machine - Code 11193 - (G4439-1).....G-4

Schematic - Entire Machine - Code 10962 - (G4320-1)G-5

Schematic - Entire Machine - Code 11086, 11216 - (G4440).....G-6

Schematic - Entire Machine - Code 11193 - (G5002).....G-7

Schematic - Entire Machine - Code 11194 - (G5003).....G-8

Schematic - Wire Drive PC Board - All Codes - (G3883 Sheet 1).....G-9

Schematic - Wire Drive PC Board - All Codes - (G3883 Sheet 2).....G-10

PC Board Assembly - Wire Drive - (G3884-2F0)G-11

Schematic - Voltage Sense PC Board - All Codes - (S24779-3C0)G-12

PC Board Assembly - Voltage Sense - (M19540-3).....G-13

Schematic - MSP4 Display PC Board - All Codes - (G4456)G-14

PC Board Assembly - MSP4 Display - (L12116-1B0).....G-15

Schematic - Display PC Board - All Codes - (L11756-2F0)G-16

PC Board Assembly - Display - (L11757-1)G-17

Schematic - Spool Gun PC Board - All Codes - (L12008-3E0)G-18

PC Board Assembly - Spool Gun - (M20159-3).....G-19

Schematic - Filter PC Board - All Codes - (M19487-2B0)G-20

PC Board Assembly - Filter - (M19488-2).....G-21

WIRING DIAGRAM - ENTIRE MACHINE - CODE 10962, 11194 (G4319-1)

WIRING DIAGRAM - POWER FEED 10M DUAL

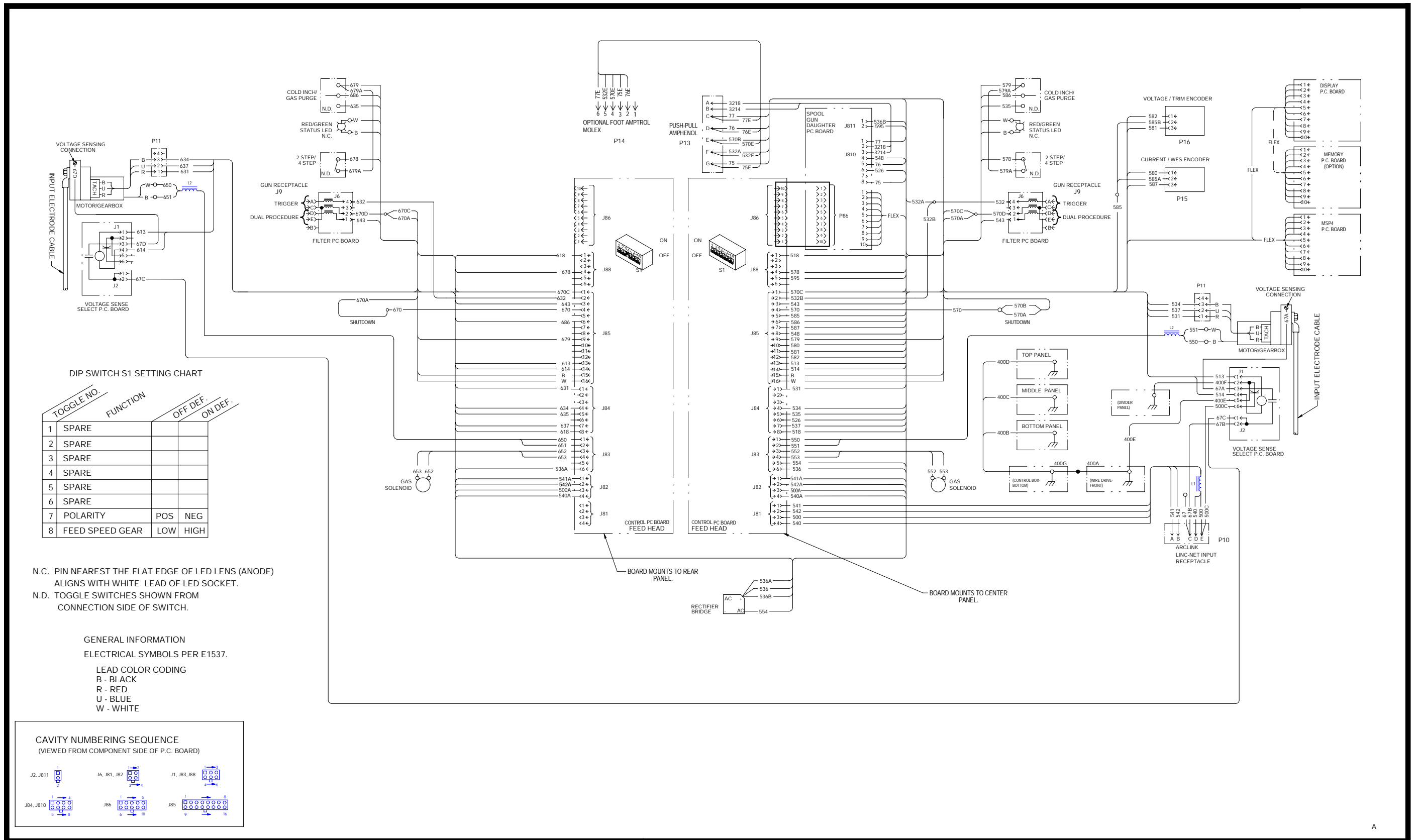

A

G4319-1

Return to Section TOC
Return to Section TOC
Return to Section TOC
Return to Section TOC
Return to Section TOC
Return to Section TOC
Return to Section TOC
Return to Section TOC

WIRING DIAGRAM - ENTIRE MACHINE - CODE 11086, 11216 (G4439)

WIRING DIAGRAM - POWER FEED 10M SINGLE FEED HEAD

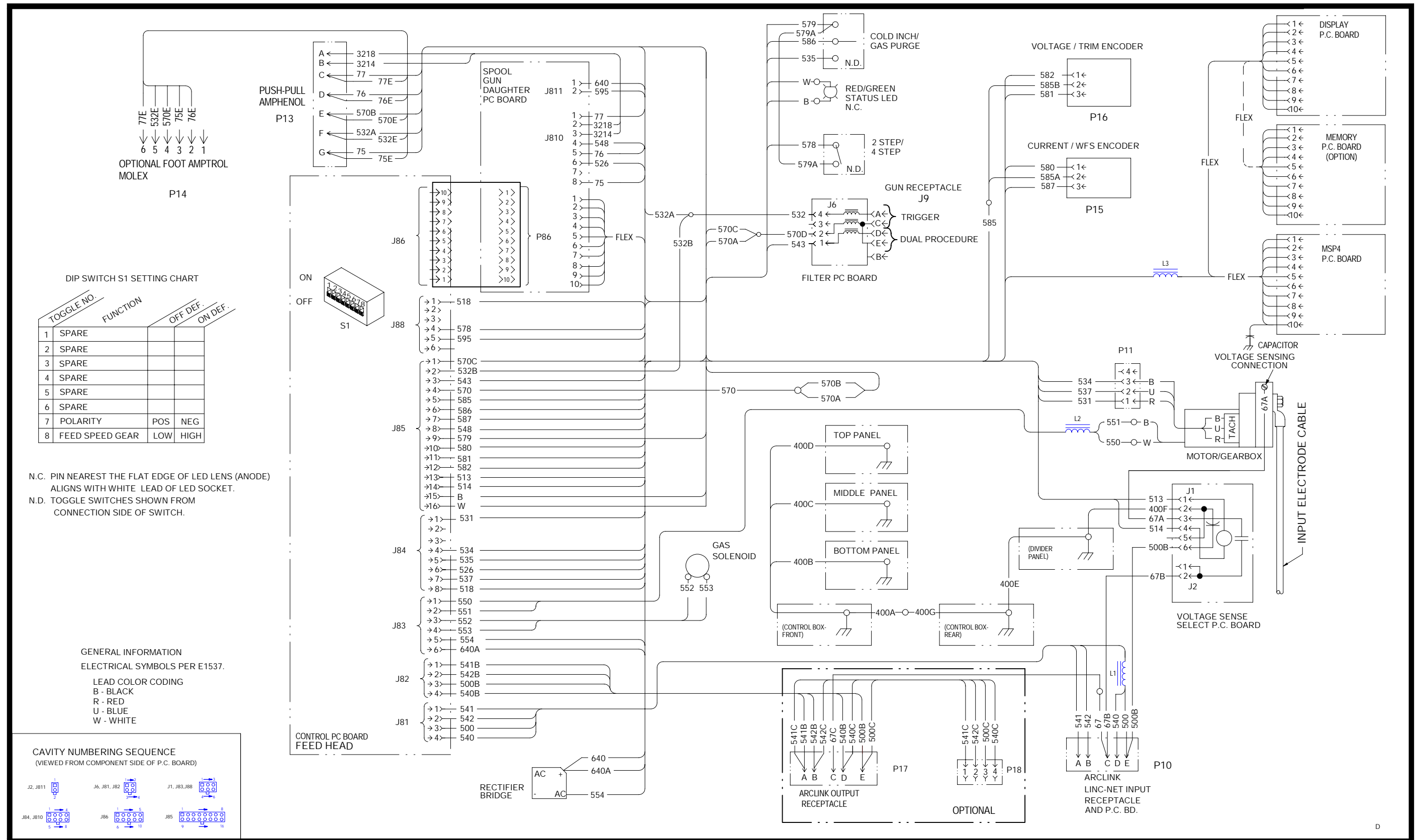

NOTE: This diagram is for reference only. It may not be accurate for all machines covered by this manual. The wiring diagram specific to your code is pasted inside one of the enclosure panels of your machine.

Return to Section TOC

Return to Section TOC

Return to Section TOC

Return to Section TOC

Return to Master TOC

Return to Master TOC

Return to Master TOC

Return to Master TOC

SCHEMATIC - ENTIRE MACHINE - CODE 10962 (G4320-1)

Return to Section TOC
Return to Section TOC
Return to Section TOC
Return to Section TOC
Return to Section TOC
Return to Section TOC
Return to Section TOC
Return to Section TOC

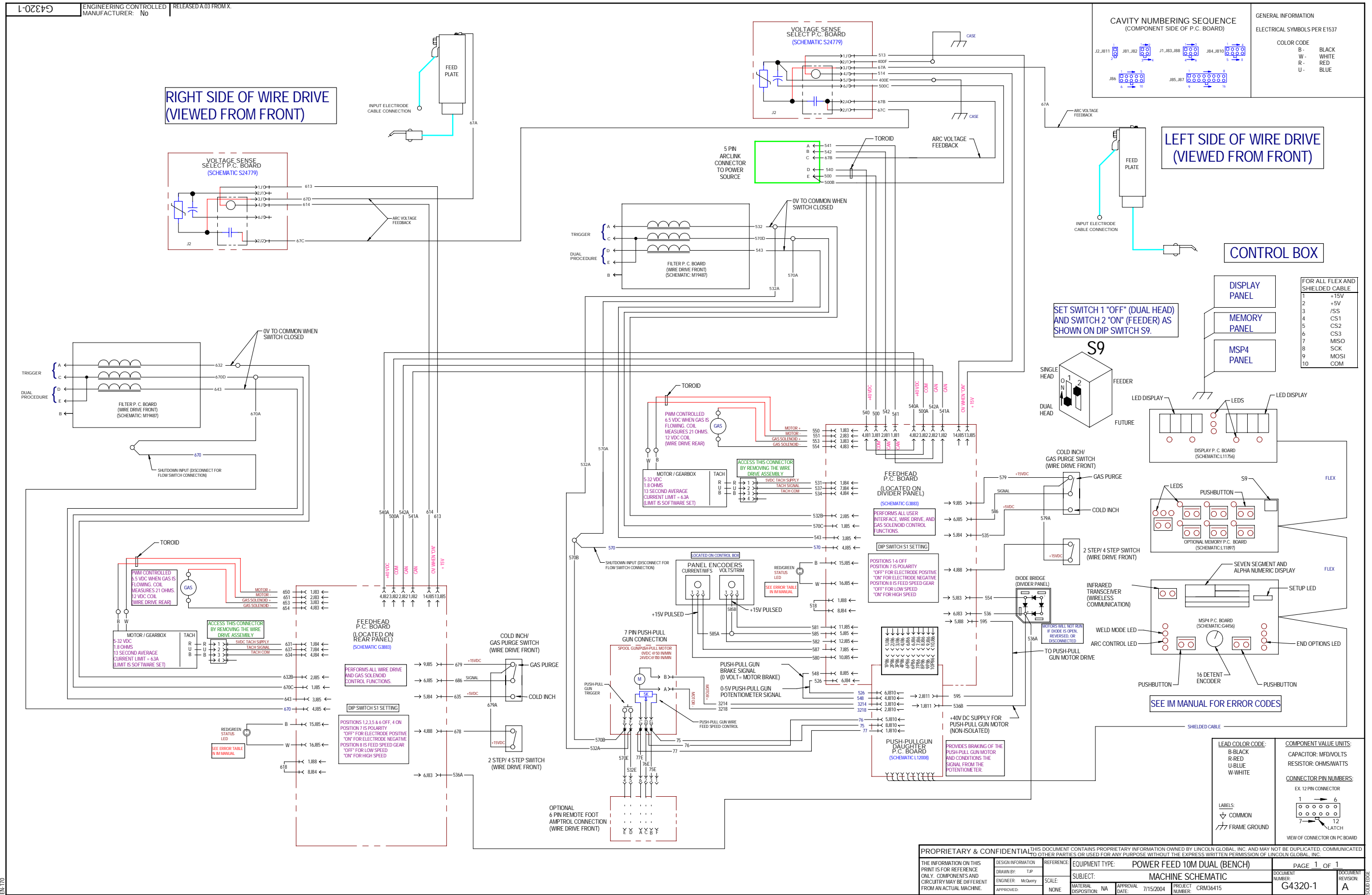

NOTE: This diagram is for reference only. It may not be accurate for all machines covered by this manual.

PROPRIETARY & CONFIDENTIAL THIS DOCUMENT CONTAINS PROPRIETARY INFORMATION OWNED BY LINCOLN GLOBAL, INC. AND MAY NOT BE DUPLICATED, COMMUNICATED TO OTHER PARTIES OR USED FOR ANY PURPOSE WITHOUT THE EXPRESS WRITTEN PERMISSION OF LINCOLN GLOBAL, INC.		EQUIPMENT TYPE: POWER FEED 10M DUAL (BENCH)		PAGE 1 OF 1	
THE INFORMATION ON THIS PRINT IS FOR REFERENCE ONLY. COMPONENTS AND CIRCUITRY MAY BE DIFFERENT FROM AN ACTUAL MACHINE.		SUBJECT: MACHINE SCHEMATIC		DOCUMENT NUMBER: G4320-1	
DESIGN INFORMATION DRAWN BY: TJP ENGINEER: McQuay APPROVED:		SCALE: NONE		PROJECT NUMBER: CRM36415	
MATERIALS DISPOSITION: NA		APPROVAL DATE: 7/15/2004		REVISION: A	



SCHEMATIC - ENTIRE MACHINE - CODE 11086, 11216 (G4440)

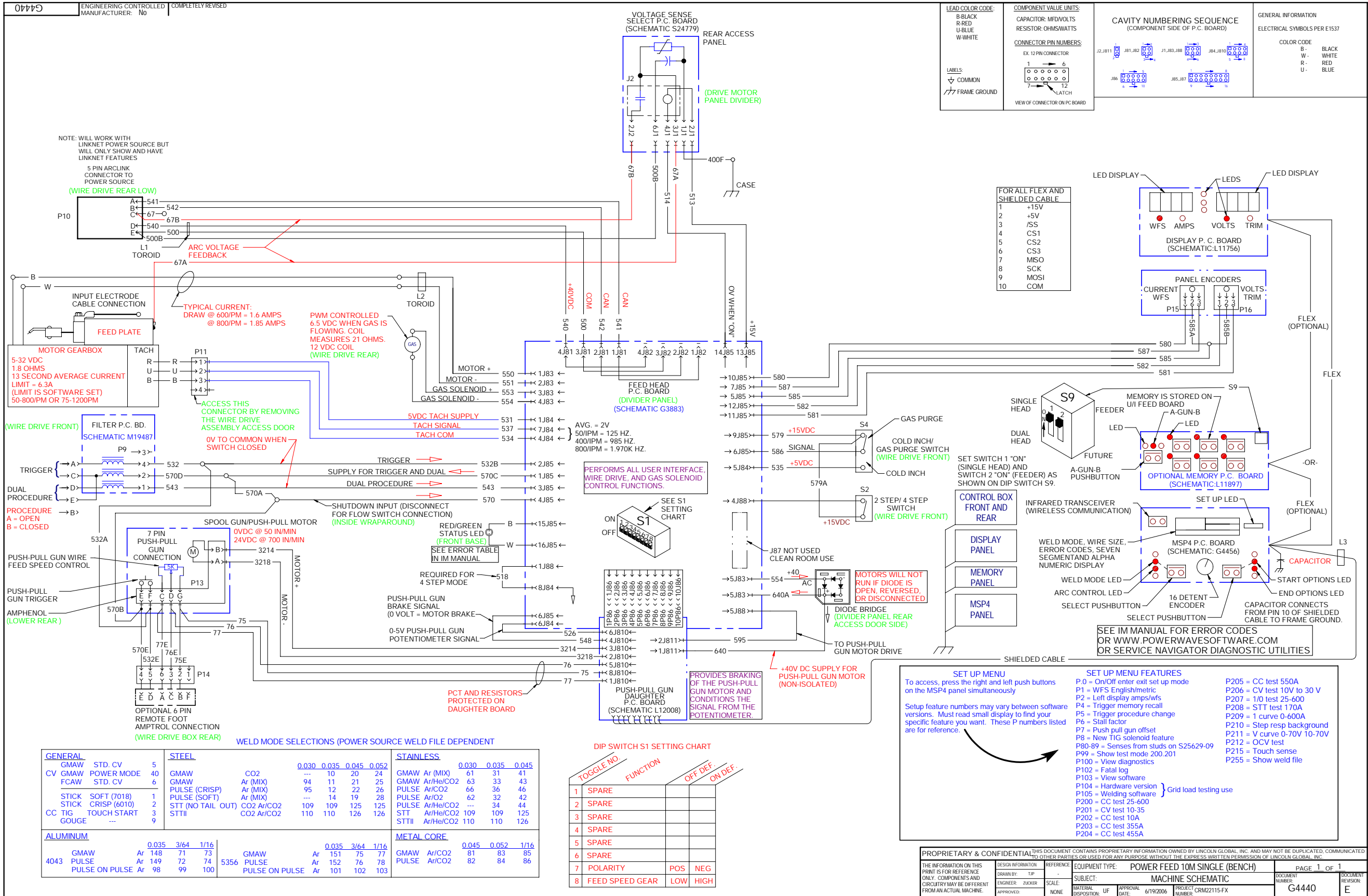

NOTE: This diagram is for reference only. It may not be accurate for all machines covered by this manual.



Return to Section TOC

Return to Section TOC

Return to Section TOC

Return to Section TOC

Return to Master TOC

Return to Master TOC

Return to Master TOC

Return to Master TOC

SCHEMATIC - ENTIRE MACHINE - CODE 11193 (G5002)

Return to Section TOC
Return to Master TOC

Return to Section TOC
Return to Master TOC

Return to Section TOC
Return to Master TOC

Return to Section TOC
Return to Master TOC

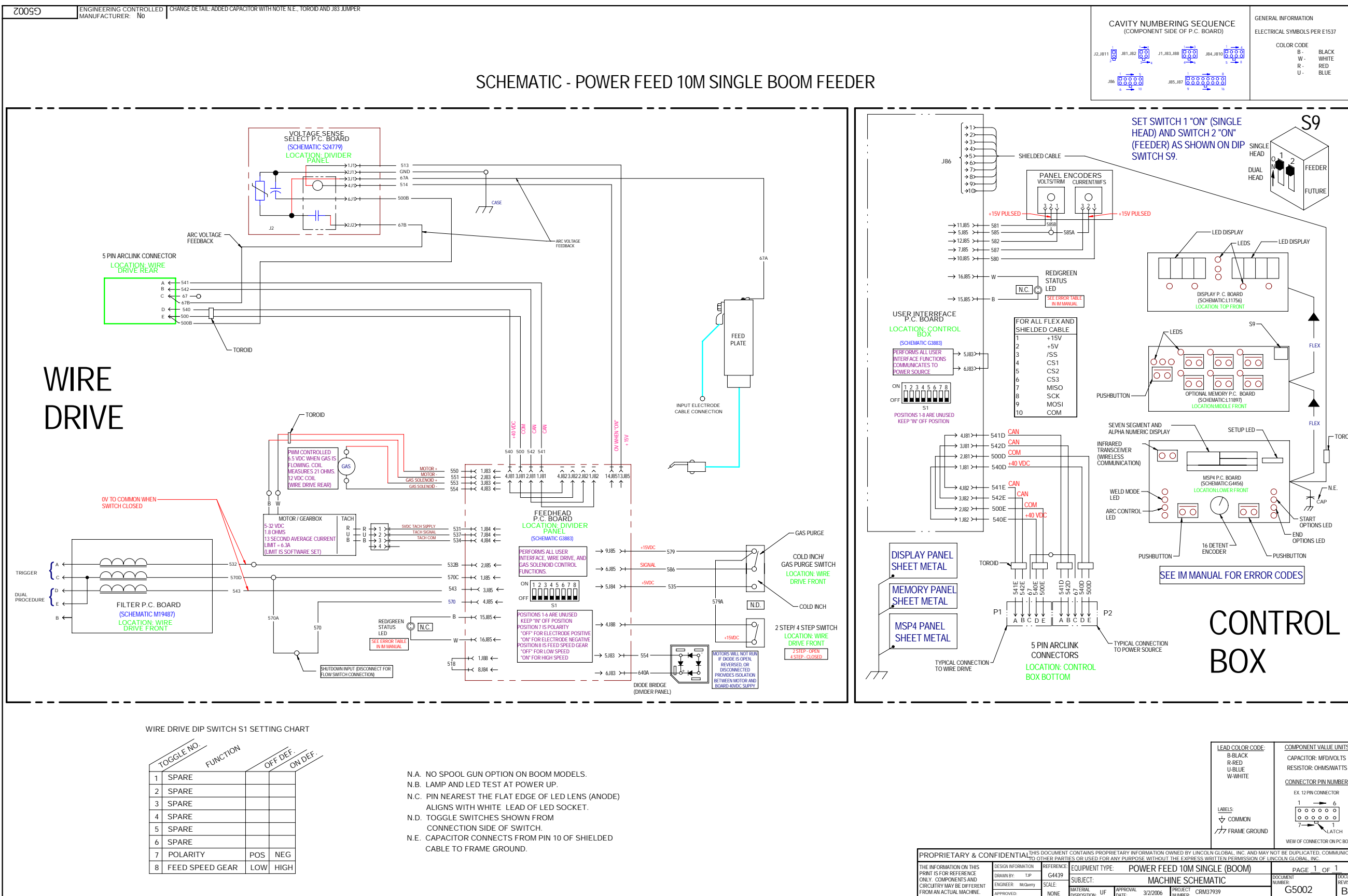

PROPRIETARY & CONFIDENTIAL THIS DOCUMENT CONTAINS PROPRIETARY INFORMATION OWNED BY LINCOLN GLOBAL, INC. AND MAY NOT BE DUPLICATED, COMMUNICATED OR USED FOR ANY PURPOSE WITHOUT THE EXPRESS WRITTEN PERMISSION OF LINCOLN GLOBAL, INC.

THE INFORMATION ON THIS PRINT IS FOR REFERENCE ONLY. COMPONENTS AND CIRCUITRY MAY BE DIFFERENT FROM AN ACTUAL MACHINE.	DESIGN INFORMATION DRAWN BY: TJP ENGINEER: MCMurry APPROVED:	REFERENCE G4439 SCALE NONE	EQUIPMENT TYPE: POWER FEED 10M SINGLE (BOOM) SUBJECT: MACHINE SCHEMATIC MATERIAL DISPOSITION: UF APPROVAL DATE: 3/2/2006 PROJECT NUMBER: CRM37939	PAGE 1 OF 1 DOCUMENT NUMBER: G5002 REVISION: B
--	---	-------------------------------------	---	--

SCHEMATIC - ENTIRE MACHINE - CODE 11194 (G5003)

Return to Section TOC

Return to Section TOC

Return to Section TOC

Return to Section TOC

ENGINEERING CONTROLLED CHANGE DETAIL: ADDED CAPACITOR WITH NOTE N.E., TOROID AND J83 JUMPER MANUFACTURER: NO

SCHEMATIC - POWER FEED 10M DUAL BOOM FEEDER

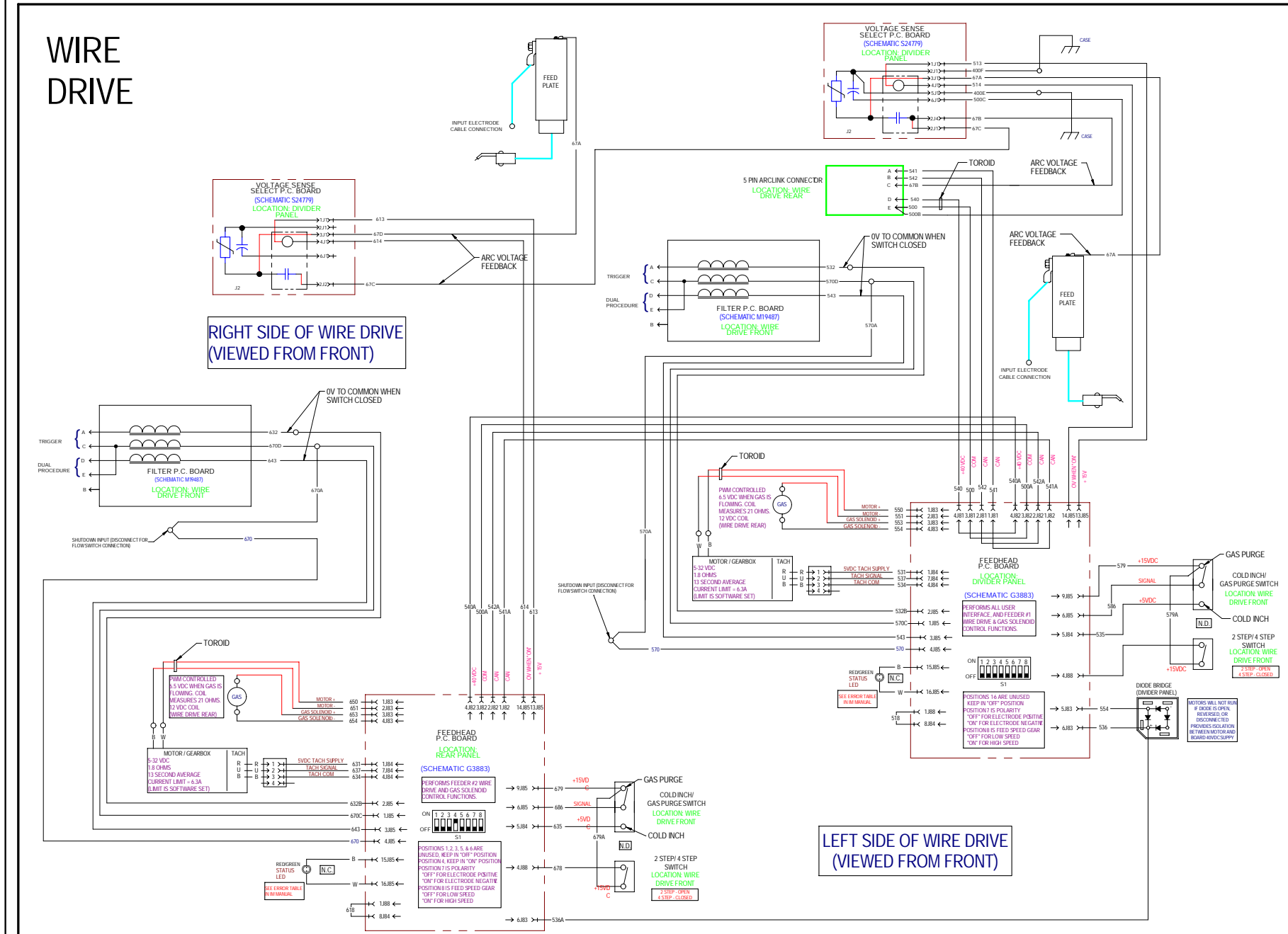

WIRE DRIVE

RIGHT SIDE OF WIRE DRIVE (VIEWED FROM FRONT)

LEFT SIDE OF WIRE DRIVE (VIEWED FROM FRONT)

CAVITY NUMBERING SEQUENCE (COMPONENT SIDE OF P.C. BOARD)

GENERAL INFORMATION
ELECTRICAL SYMBOLS PER E1537

COLOR CODE

B -	BLACK
W -	WHITE
R -	RED
U -	BLUE

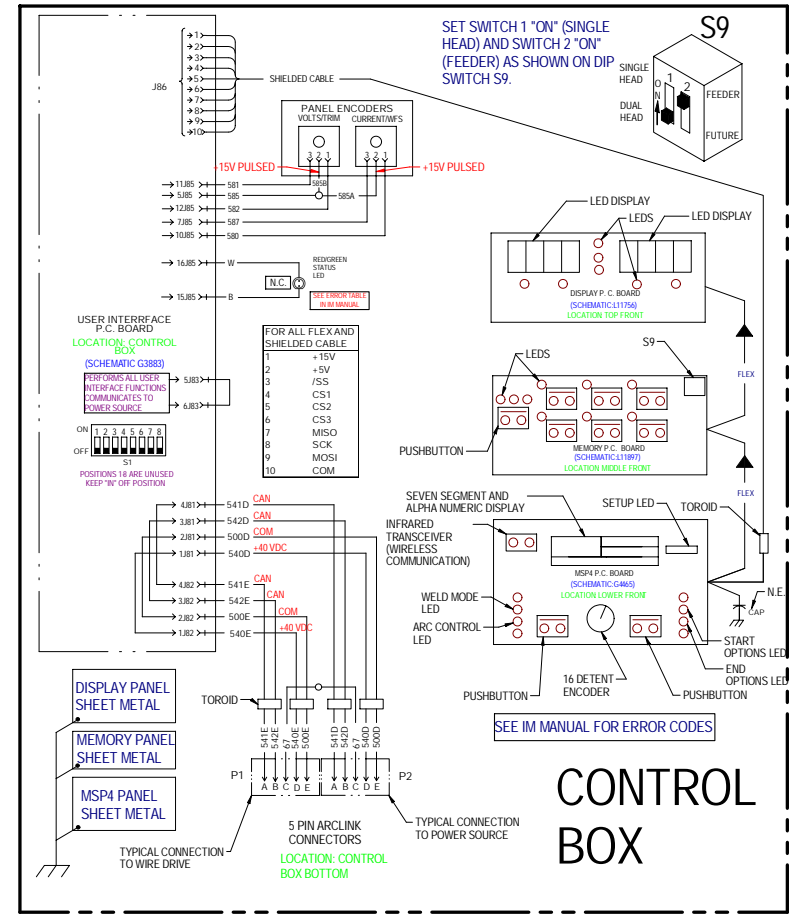

WIRE DRIVE DIP SWITCH S1 SETTING CHART

TOGGLE NO.	FUNCTION	OFF DEF.	ON DEF.
1	SPARE		
2	SPARE		
3	SPARE		
4	SPARE		
5	SPARE		
6	SPARE		
7	POLARITY	POS	NEG
8	FEED SPEED GEAR	LOW	HIGH

- N.A. NO SPOOL GUN OPTION ON BOOM MODELS.
- N.B. LAMP AND LED TEST AT POWER UP.
- N.C. PIN NEAREST THE FLAT EDGE OF LED LENS (ANODE) ALIGNS WITH WHITE LEAD OF LED SOCKET.
- N.D. TOGGLE SWITCHES SHOWN FROM CONNECTION SIDE OF SWITCH.
- N.E. CAPACITOR CONNECTS FROM PIN 10 OF SHIELDED CABLE TO FRAME GROUND.

LEAD COLOR CODE:
B-BLACK
R-RED
U-BLUE
W-WHITE

COMPONENT VALUE UNITS:
CAPACITOR: MFD/VOLTS
RESISTOR: OHMS/WATTS

CONNECTOR PIN NUMBERS:
EX. 12 PIN CONNECTOR

VIEW OF CONNECTOR ON P.C. BOARD

PROPRIETARY & CONFIDENTIAL THIS DOCUMENT CONTAINS PROPRIETARY INFORMATION OWNED BY LINCOLN GLOBAL, INC. AND MAY NOT BE DUPLICATED, COMMUNICATED OR USED FOR ANY PURPOSE WITHOUT THE EXPRESS WRITTEN PERMISSION OF LINCOLN GLOBAL, INC.

THE INFORMATION ON THIS PRINT IS FOR REFERENCE ONLY. COMPONENTS AND CIRCUITRY MAY BE DIFFERENT FROM AN ACTUAL MACHINE.	DESIGN INFORMATION DRAWN BY: TJP ENGINEER: MCMary APPROVED:	REFERENCE G4319	EQUIPMENT TYPE: POWER FEED 10M DUAL (BOOM)	PAGE 1 OF 1
			SUBJECT: MACHINE SCHEMATIC	DOCUMENT NUMBER: G5003
			MATERIAL DISPOSITION: UF APPROVAL DATE: 3/2/2006 PROJECT NUMBER: CRM37939	DOCUMENT REVISION: B

NOTE: This diagram is for reference only. It may not be accurate for all machines covered by this manual.



SCHEMATIC - WIRE DRIVE PC BOARD - (G3883 SHEET 1)

Return to Section TOC

Return to Section TOC

Return to Section TOC

Return to Section TOC

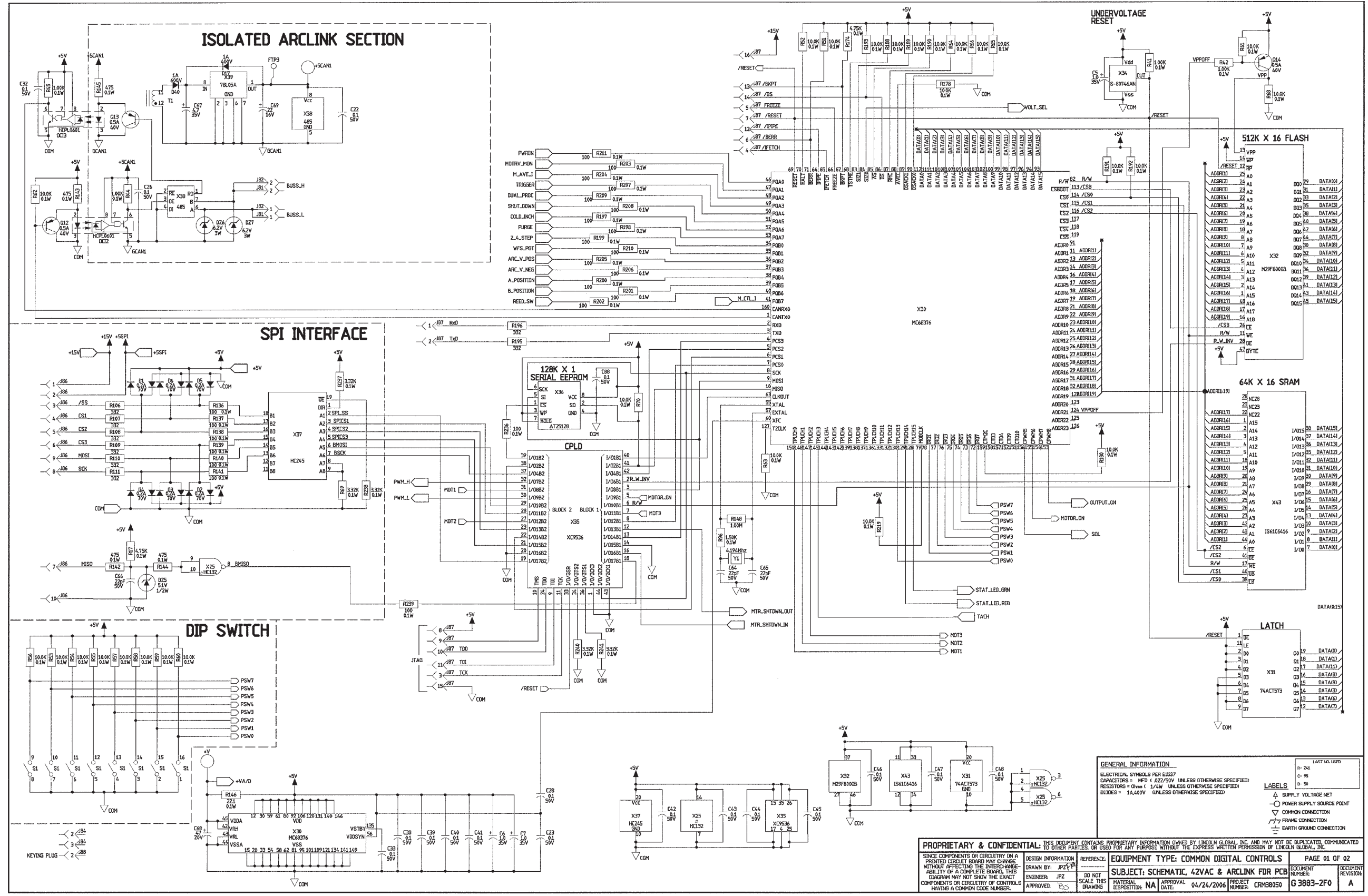

NOTE: This diagram is for reference only. It may not be accurate for all machines covered by this manual.

SCHEMATIC - WIRE DRIVE PC BOARD - ALL CODES - (G3883 SHEET 2)

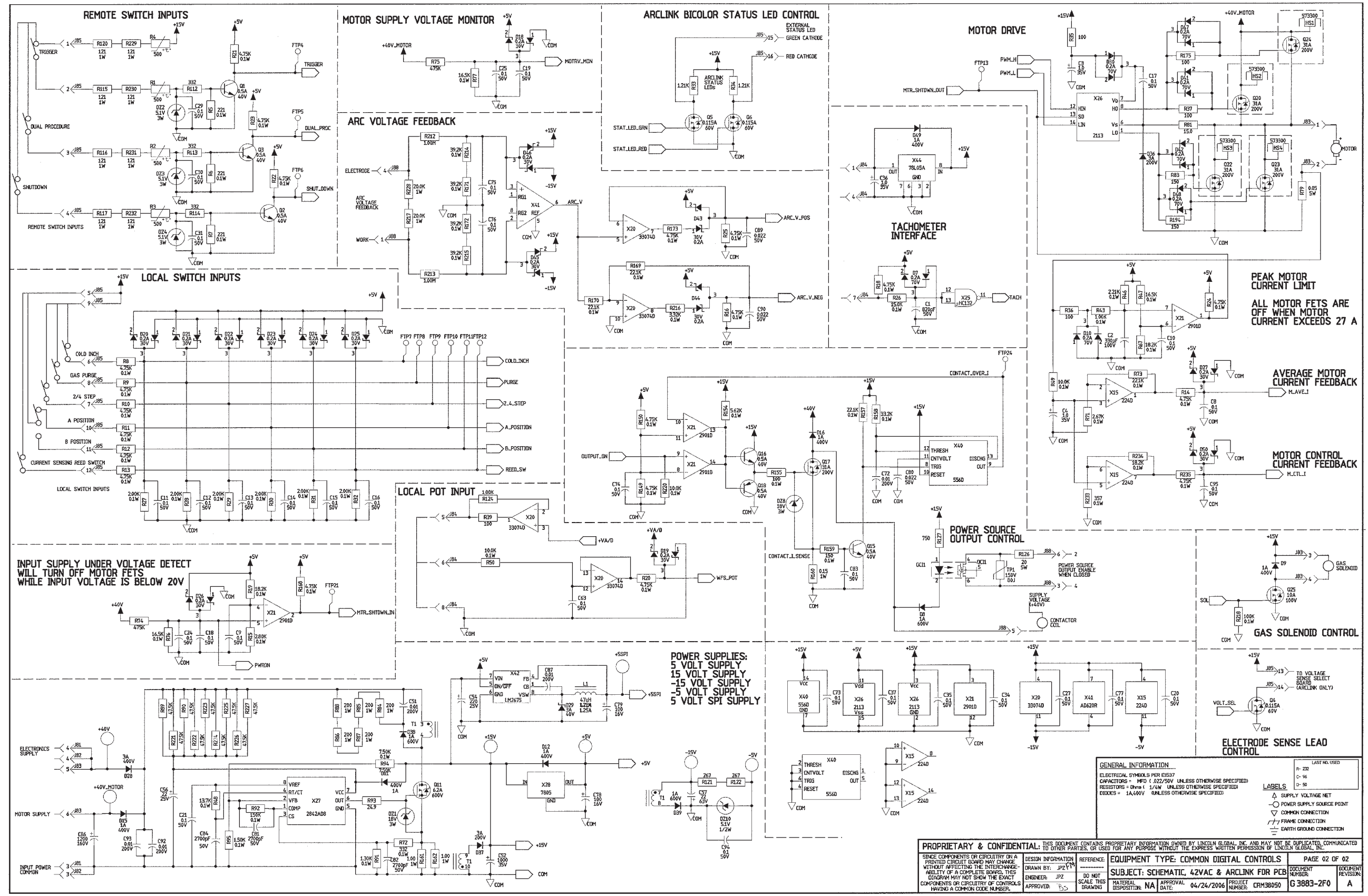

GENERAL INFORMATION

ELECTRICAL SYMBOLS PER EHS37
 CAPACITORS = MFD 0.022/50V UNLESS OTHERWISE SPECIFIED
 RESISTORS = OHMS 1/4W UNLESS OTHERWISE SPECIFIED
 DIODES = 1A/400V UNLESS OTHERWISE SPECIFIED

LABELS

- △ SUPPLY VOLTAGE NET
- POWER SUPPLY SOURCE POINT
- ▽ COMMON CONNECTION
- FRAME CONNECTION
- ⊕ EARTH GROUND CONNECTION

LAST REVISED: R-232
 C-96
 D-50

PROPRIETARY & CONFIDENTIAL		THIS DOCUMENT CONTAINS PROPRIETARY INFORMATION OWNED BY LINCOLN GLOBAL, INC. AND MAY NOT BE DUPLICATED, COMMUNICATED TO OTHER PARTIES, OR USED FOR ANY PURPOSE WITHOUT THE EXPRESS WRITTEN PERMISSION OF LINCOLN GLOBAL, INC.	
DESIGN INFORMATION	REFERENCE:	EQUIPMENT TYPE: COMMON DIGITAL CONTROLS	PAGE 02 OF 02
SINCE COMPONENTS OR CIRCUITRY ON A PRINTED CIRCUIT BOARD MAY CHANGE WITHOUT AFFECTING THE INTERCHANGEABILITY OF A COMPLETE BOARD, THIS DRAWING MAY NOT SHOW THE EXACT COMPONENTS OR CIRCUITRY OF CONTROLS HAVING A COMMON CODE NUMBER.	DESIGNER: JPZ DRAWN BY: JPZ ENGINEER: JPZ APPROVED: TSS	SUBJECT: SCHEMATIC, 42VAC & ARLINK FOR PCB MATERIAL: NA DATE: 04/24/2006 PROJECT NUMBER: CRM38050	DOCUMENT NUMBER: G3883-2F0 REVISION: A

NOTE: This diagram is for reference only. It may not be accurate for all machines covered by this manual.



Return to Section TOC

Return to Master TOC

Return to Section TOC

Return to Master TOC

Return to Section TOC

Return to Master TOC

Return to Section TOC

Return to Master TOC

PC BOARD ASSEMBLY - WIRE DRIVE - ALL CODES - (G3884-2F0)

ENGINEERING CONTROLLED CHANGE DETAIL: CHANGED FROM A BUY TO A MAKE OR BUY AND ADDED MAKE INFO. MANUFACTURER: Yes ADDED '4 LAYER BOARD BLANK PANEL'

Table with columns: ITEM, QTY, PART No, DESCRIPTION. Lists components like PLUG KEVIN PLUG, FLOTTING TRAY, SELF TAPPING SCREW, etc.

Table with columns: ITEM, QTY, PART No, DESCRIPTION. Lists electronic components like CAPACITOR, RESISTOR, DIODE, TRANSISTOR, etc.

Table with columns: ITEM, QTY, PART No, DESCRIPTION. Lists electronic components like DIODE, TRANSISTOR, RESISTOR, etc.

Table with columns: ITEM, QTY, PART No, DESCRIPTION. Lists electronic components like TRANSISTOR, RESISTOR, CAPACITOR, etc.

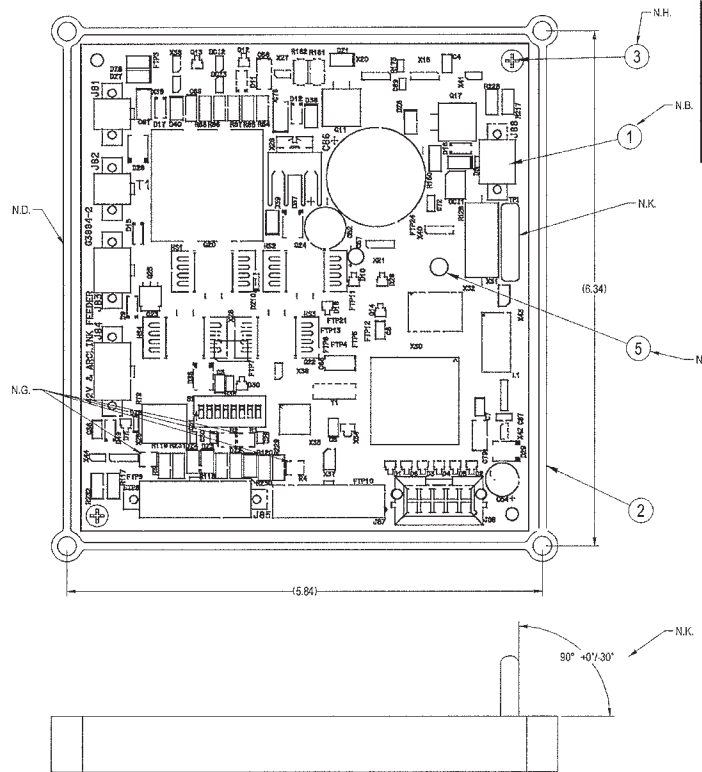

NOTES: CAUTION: THIS DEVICE IS SUBJECT TO DAMAGE BY STATIC ELECTRICITY. SEE E2454 BEFORE HANDLING. N.B. PLACE ITEM 1 OVER HEADER PIN IN LOCATION SHOWN...

REVISION CONTROL box for part G3884-2F0, containing test and manufacturing information.

ALL COMPONENTS AND MATERIALS USED IN THIS ASSEMBLY ARE TO BE RoHS COMPLIANT PER E4253.

Technical specification table with columns for PROPRIETARY & CONFIDENTIAL, DESIGN INFORMATION, EQUIPMENT TYPE, SUBJECT, SCALE, MATERIAL, APPROVAL, and DOCUMENT NUMBER.



NOTE: Lincoln Electric assumes no responsibility for liabilities resulting from board level troubleshooting. PC Board repairs will invalidate your factory warranty.

POWER FEED 10M SINGLE/DUAL

Return to Section TOC

Return to Section TOC

Return to Section TOC

Return to Section TOC

Return to Master TOC

Return to Master TOC

Return to Master TOC

Return to Master TOC

SCHEMATIC - VOLTAGE SENSE PC BOARD - ALL CODES - (S24779-3C0)

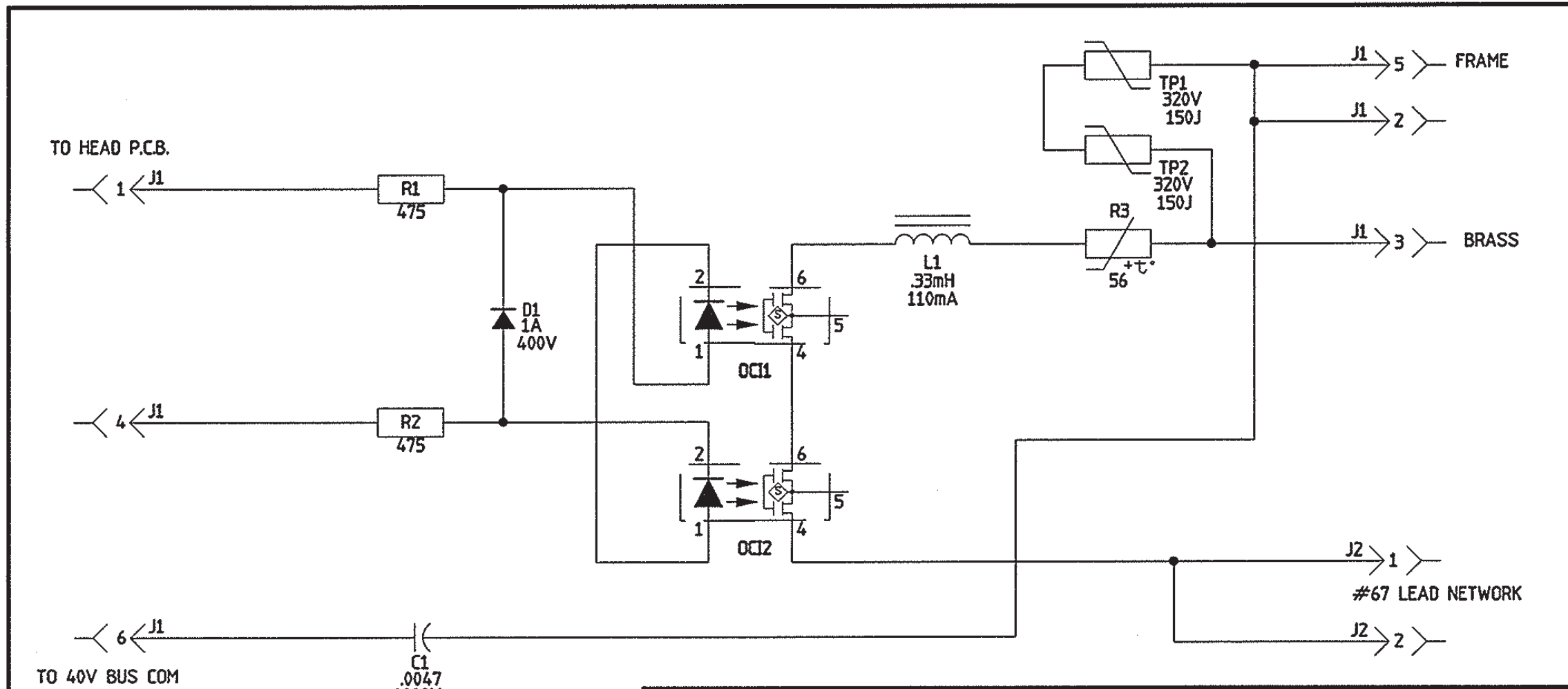

GENERAL INFORMATION

ELECTRICAL SYMBOLS PER E1537
 CAPACITORS = MFD (.022/50V UNLESS OTHERWISE SPECIFIED)
 RESISTORS = Ohms (1/4W UNLESS OTHERWISE SPECIFIED)
 DIODES = 1A,400V (UNLESS OTHERWISE SPECIFIED)

LAST NO. USED	
R-	3
C-	1
D-	1

LABELS

- ▲ SUPPLY VOLTAGE NET
- POWER SUPPLY SOURCE POINT
- ▽ COMMON CONNECTION
- ≡ FRAME CONNECTION
- ⊥ EARTH GROUND CONNECTION

PROPRIETARY & CONFIDENTIAL: THIS DOCUMENT CONTAINS PROPRIETARY INFORMATION OWNED BY LINCOLN GLOBAL, INC. AND MAY NOT BE DUPLICATED, COMMUNICATED TO OTHER PARTIES, OR USED FOR ANY PURPOSE WITHOUT THE EXPRESS WRITTEN PERMISSION OF LINCOLN GLOBAL, INC.

SINCE COMPONENTS OR CIRCUITRY ON A PRINTED CIRCUIT BOARD MAY CHANGE WITHOUT AFFECTING THE INTERCHANGEABILITY OF A COMPLETE BOARD, THIS DIAGRAM MAY NOT SHOW THE EXACT COMPONENTS OR CIRCUITRY OF CONTROLS HAVING A COMMON CODE NUMBER.

DESIGN INFORMATION	REFERENCE:
DRAWN BY: JPZ FM	-----
ENGINEER: JPZ	DO NOT SCALE THIS DRAWING
APPROVED: BS	

EQUIPMENT TYPE:	WIRE FEEDERS
SUBJECT: SCHEMATIC, V SENSE SELECT PCB	
MATERIAL DISPOSITION: NA	APPROVAL DATE: 04/24/2006
PROJECT NUMBER: CRM38050	

PAGE 01 OF 01	
DOCUMENT NUMBER:	DOCUMENT REVISION:
S 24779-3C0	A

NOTE: Lincoln Electric assumes no responsibility for liabilities resulting from board level troubleshooting. PC Board repairs will invalidate your factory warranty. **Individual Printed Circuit Board Components are not available from Lincoln Electric.** This information is provided for reference only. Lincoln Electric discourages board level troubleshooting and repair since it may compromise the quality of the design and may result in danger to the Machine Operator or Technician. Improper PC board repairs could result in damage to the machine.



Return to Section TOC
Return to Master TOC

PC BOARD ASSEMBLY - VOLTAGE SENSE - ALL CODES - (M19540-3)

Return to Section TOC
Return to Master TOC

Return to Section TOC
Return to Master TOC

Return to Section TOC
Return to Master TOC

Return to Section TOC
Return to Master TOC

M19540-3

ENGINEERING CONTROLLED
MANUFACTURER: No

CHANGE DETAIL: REVISED P.C. BOARD BLANK INFORMATION NOTE INCLUDING CHANGING IT TO A BUY ITEM

P.C. BOARD BLANK INFORMATION
BUY COMPLETE AS M19540-C
(2 LAYER BOARD PER E3281)
(MAKES 54 BOARDS PER PANEL, SEE ELECTRONIC FILE
FOR ADDITIONAL INFORMATION)

ITEM	REQD	PART NO.	IDENTIFICATION
C1	1	S20500-4	.0047 1000V
D1	1	T12199-1	1N4004
N.A. J1	1	S24020-6	HEADER
N.A. J2	1	S24020-2G	HEADER
L1	1	T12218-7	330uH
OC1,OC2	2	S15000-20	PHOTO FET
R1,R2	2	S19400-4750	475 1/4W
R3	1	S18380-1	THERMISTOR,PTC
TP1,TP2	2	T13640-18	160J

CAPACITORS = MFD/VOLTS
RESISTORS = OHMS
INDUCTANCE = HENRYS

ITEM	REQD	PART NO.	DESCRIPTION
1	1	SEE BLANK INFO	P.C. BOARD BLANK

SCHEMATIC REFERENCE: S24779-3CO

N.A. DO NOT COAT WITH ENCAPSULATION MATERIAL.
N.B. DO NOT COAT WITH ENCAPSULATION MATERIAL
.23 MIN. DIA. (3 PLACES) ON NON COMPONENT SIDE.

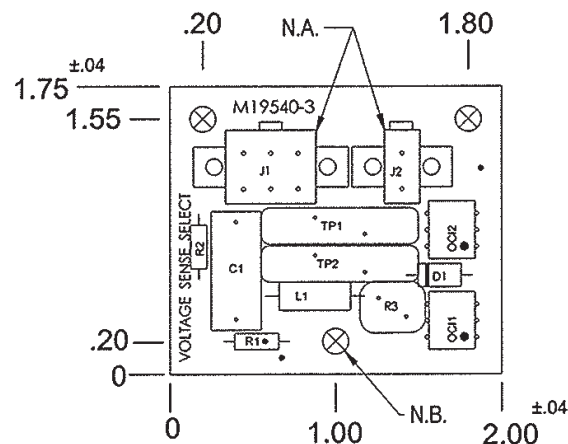

MANUFACTURED AS
M19540-3CO
IDENTIFICATION CODE

MAKE PER E1911
ENCAPSULATE WITH E1844 (2 DIPS)
TEST PER E3689-VS

ALL COMPONENTS AND MATERIALS USED IN THIS
ASSEMBLY ARE TO BE RoHS COMPLIANT PER E4253.

PROPRIETARY & CONFIDENTIAL - THIS DOCUMENT CONTAINS PROPRIETARY INFORMATION OWNED BY LINCOLN GLOBAL, INC. AND MAY NOT BE DUPLICATED, COMMUNICATED TO OTHER PARTIES OR USED FOR ANY PURPOSE WITHOUT THE EXPRESS WRITTEN PERMISSION OF LINCOLN GLOBAL, INC.							
UNLESS OTHERWISE SPECIFIED TOLERANCE MANUFACTURING TOLERANCE PER E2056 ON 2 PLACE DECIMALS IS ± .02 ON 3 PLACE DECIMALS IS ± .002 ON ALL ANGLES IS ± 5 OF A DEGREE MATERIAL TOLERANCE ("1") TO AGREE WITH PUBLISHED STANDARDS. DO NOT SCALE THIS DRAWING	DESIGN INFORMATION	REFERENCE:	EQUIPMENT TYPE: COMMON DIGITAL CONTROLS		PAGE 1 OF 1		
	DRAWN BY: FEI	M19540-2	SUBJECT: VOLTAGE SENSE PC BRD AS'BLY		DOCUMENT NUMBER:	DOCUMENT REVISION: B	
	ENGINEER:	SCALE: 1:1	MATERIAL DISPOSITION: UF	APPROVAL DATE: 8/3/2006	PROJECT NUMBER: CRM38146-A	M19540-3	
	APPROVED: Djs						

NOTE: This diagram is for reference only. It may not be accurate for all machines covered by this manual.

SCHEMATIC - MSP4 DISPLAY PC BOARD - ALL CODES - (G4456)

Return to Section TOC
Return to Master TOC

Return to Section TOC
Return to Master TOC

Return to Section TOC
Return to Master TOC

Return to Section TOC
Return to Master TOC

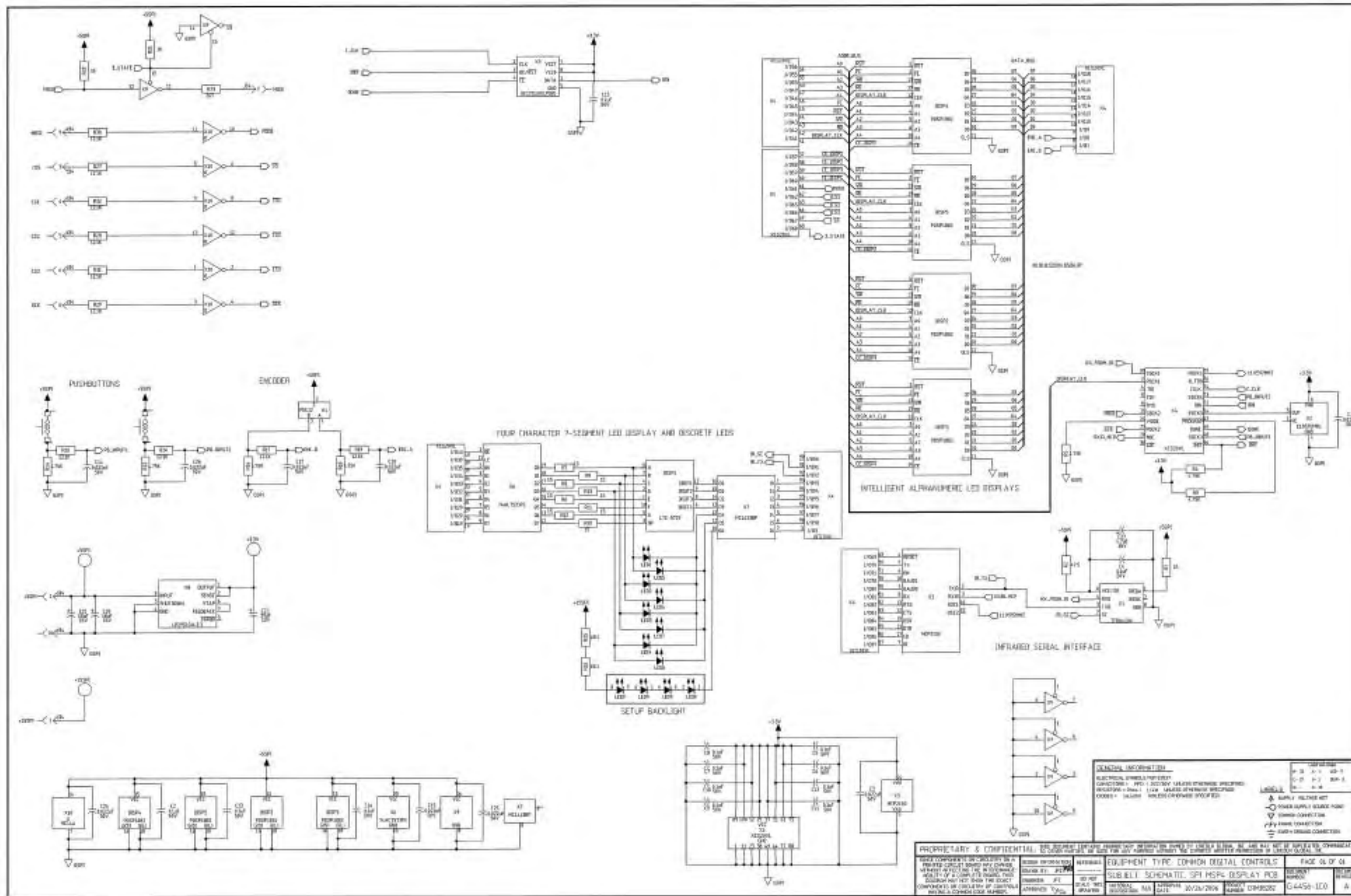

NOTE: This diagram is for reference only. It may not be accurate for all machines covered by this manual.



PC BOARD ASSEMBLY - MSP4 DISPLAY - ALL CODES - (L12116-1B0)

Return to Section TOC
Return to Master TOC

Return to Section TOC
Return to Master TOC

Return to Section TOC
Return to Master TOC

Return to Section TOC
Return to Master TOC

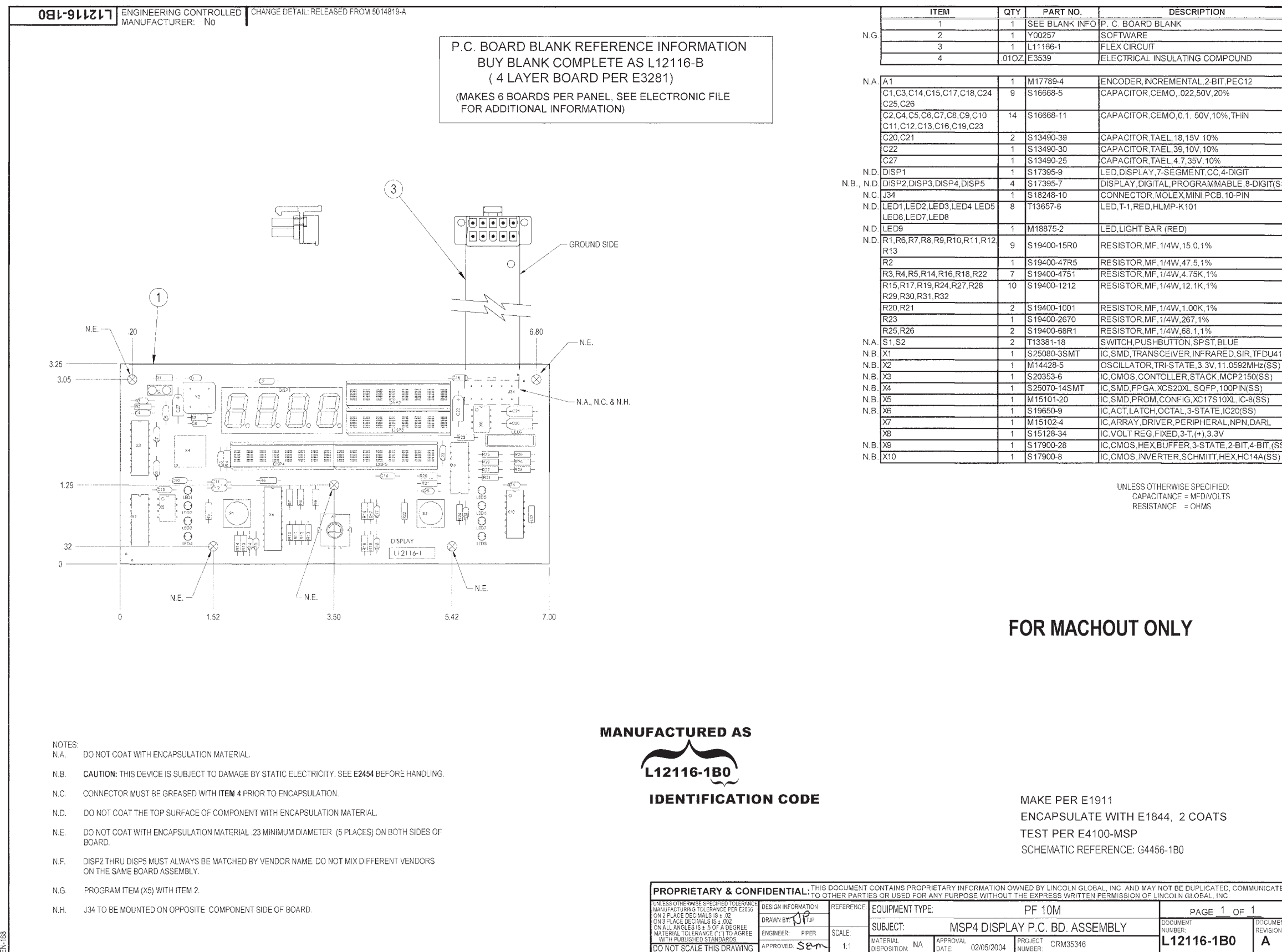

NOTE: Lincoln Electric assumes no responsibility for liabilities resulting from board level troubleshooting. PC Board repairs will invalidate your factory warranty. **Individual Printed Circuit Board Components are not available from Lincoln Electric.** This information is provided for reference only. Lincoln Electric discourages board level troubleshooting and repair since it may compromise the quality of the design and may result in danger to the Machine Operator or Technician. Improper PC board repairs could result in damage to the machine.

PC BOARD ASSEMBLY - DISPLAY - ALL CODES - (L11757-1)

Return to Section TOC
Return to Master TOC

Return to Section TOC
Return to Master TOC

Return to Section TOC
Return to Master TOC

Return to Section TOC
Return to Master TOC

L11757-1	ENGINEERING CONTROLLED MANUFACTURER: Yes	CHANGE DETAIL: LED5, 6 & 7, REVISED PART NUMBER AND DESCRIPTION. REVISED IDENTIFICATION CODE AND SCHEMATIC REF. NUMBER.
-----------------	---	---

ITEM / REFERENCE DESIGNATORS	QTY	PART NUMBER	DESCRIPTION
1	1	L11757-E	P.C. BOARD BLANK
2	4	T15176-2	LED, SPACER, 0.140 HIGH
3	.01 OZ.	E3539	ELECTRICAL INSULATING COMPOUND
FOR ITEMS BELOW REFER TO ELECTRONIC COMPONENTS DATABASE FOR COMPONENT SPECIFICATIONS			
C1	1	S25024-7SMT	CAPACITOR,SMD,TANTALUM,47MF,20V,10%,S7343
C2, C3, C4, C5, C11, C12, C19, C20	8	S25020-3SMT	CAPACITOR,SMD,CERAMIC,0.1MF,50V,10%,X7R,S0805
DISP1, DISP2	2	S17395-9	LED,DISPLAY,7-SEGMENT,CC,4-DIGIT
J37	1	S18248-10	CONNECTOR,MOLEX,MINI,PCB,10-PIN
N.C. LED1, LED2, LED3, LED4	4	T13657-6	LED,T-1,RED,HLM-P-K101
N.A. LED5, LED6, LED7	3	T13657-14	LED,T-1,3/4,AMBER,HIGH-INTENSITY
R6, R16	2	S25000-1501SMT	RESISTOR,SMD,METAL FILM,1/10W,1.50K,1%,S0805
R9, R10, R11, R12, R13, R14	6	S25000-1212SMT	RESISTOR,SMD,METAL FILM,1/10W,12.1K,1%,S0805
R20	1	S25000-2670SMT	RESISTOR,SMD,METAL FILM,1/10W,267OHMS,1%,S0805
R21, R25, R26, R28, R29	5	S25000-1001SMT	RESISTOR,SMD,METAL FILM,1/10W,1.00K,1%,S0805
R22, R23	2	S25000-10R0SMT	RESISTOR,SMD,METAL FILM,1/10W,10.0OHMS,1%,S0805
R24	1	S25000-4751SMT	RESISTOR,SMD,METAL FILM,1/10W,4.75K,1%,S0805
R27	1	S25000-4752SMT	RESISTOR,SMD,METAL FILM,1/10W,47.5K,1%,S0805
N.A. X1	1	S17900-8SMT	IC,SMD,CMOS,INVERTER,SCHMITT,HEX,HC14A(SS)
N.A. X2	1	S17900-26SMT	IC,CMOS,SMD,MUX,DAT,8-INPUT,HC151(SS)
N.A. X3	1	S17900-28SMT	IC,SMD,CMOS,HEX INVERTING BUFFER,3-ST(SS)
N.A. X4	1	S17900-10SMT	IC,SMD,CMOS,REGISTER,SHIFT,S-P/SO,8-BIT(SS)
N.A. X5, X6, X7	3	S20496-1SMT	IC,SMD,CMOS,DRIVER,DISPLAY,LED,CC,MCU

SCHEMATIC REFERENCE: L11756-1E1

UNLESS OTHERWISE SPECIFIED:
CAPCITANCE = MFD/VOLTS
RESISTANCE = OHMS
INDUCTANCE = HENRIES

NOTE:
N.A. CAUTION: THIS DEVICE SUBJECT TO DAMAGE BY STATIC ELECTRICITY. SEE E2454 BEFORE HANDLING.
N.B. DO NOT COAT WITH ENCAPSULATION MATERIAL.
N.C. USE ITEM 2 TO STAND LED1, LED2, LED3 AND LED4 FROM THE P.C. BOARD. THERE MUST NOT BE MORE THAN .020 GAP BETWEEN SPACER AND P.C. BOARD OR BETWEEN SPACER AND LED. ENCAPSULATE P.C. BOARD, SPACER AND LOWER HALF OF LED.
N.D. DISP1 AND DISP2 MUST ALWAYS BE MATCHED BY VENDOR NAME. DO NOT MIX DIFFERENT VENDORS ON THE SAME BOARD ASSEMBLY. ENCAPSULATE LOWER HALF OF DISPLAYS ONLY, FACE AND UPPER HALF MUST BE FREE OF ENCAPSULATION.
N.E. CONNECTOR MUST BE GREASED WITH ITEM 3 PRIOR TO ENCAPSULATION.

BUY AS:

L11757-1E1

IDENTIFICATION CODE

ENCAPSULATE WITH HUMISEAL 1A27LU
PER E1844 OR WITH EQUIVALENT AS
APPROVED BY LINCOLN ELECTRIC COMPANY.
(2 COATS)

BUY PER E3867
TEST PER E3856-D

PROPRIETARY & CONFIDENTIAL: THIS DOCUMENT CONTAINS PROPRIETARY INFORMATION OWNED BY LINCOLN GLOBAL, INC. AND MAY NOT BE DUPLICATED, COMMUNICATED TO OTHER PARTIES OR USED FOR ANY PURPOSE WITHOUT THE EXPRESS WRITTEN PERMISSION OF LINCOLN GLOBAL, INC.			
<small>MANUFACTURING TOLERANCE PER ASME Y14.5 UNLESS OTHERWISE SPECIFIED TOLERANCE: ON 2 PLACE DECIMALS IS ± .02 ON 3 PLACE DECIMALS IS ± .002 ON ALL ANGLES IS ± 5° OF A DEGREE MATERIAL TOLERANCE (1") TO AGREE WITH PUBLISHED STANDARDS. DO NOT SCALE THIS DRAWING</small>	DESIGN INFORMATION DRAWN BY: <i>gbradde</i> ENGINEER: APPROVED: <i>DLG</i>	REFERENCE: EQUIPMENT TYPE: MISCELLANEOUS SUBJECT: SPI DISPLAY P.C. BOARD ASSEMBLY SCALE: 1:1	MATERIAL DISPOSITION: UF APPROVAL DATE: 11/05/2004 PROJECT NUMBER: CRM36635
		PAGE 1 OF 1	DOCUMENT NUMBER: L11757-1 DOCUMENT REVISION: A

NOTE: Lincoln Electric assumes no responsibility for liabilities resulting from board level troubleshooting. PC Board repairs will invalidate your factory warranty. **Individual Printed Circuit Board Components are not available from Lincoln Electric.** This information is provided for reference only. Lincoln Electric discourages board level troubleshooting and repair since it may compromise the quality of the design and may result in danger to the Machine Operator or Technician. Improper PC board repairs could result in damage to the machine.



SCHEMATIC - SPOOL GUN PC BOARD - ALL CODES - (L12008-3E0)

Return to Section TOC
Return to Master TOC

Return to Section TOC
Return to Master TOC

Return to Section TOC
Return to Master TOC

Return to Section TOC
Return to Master TOC

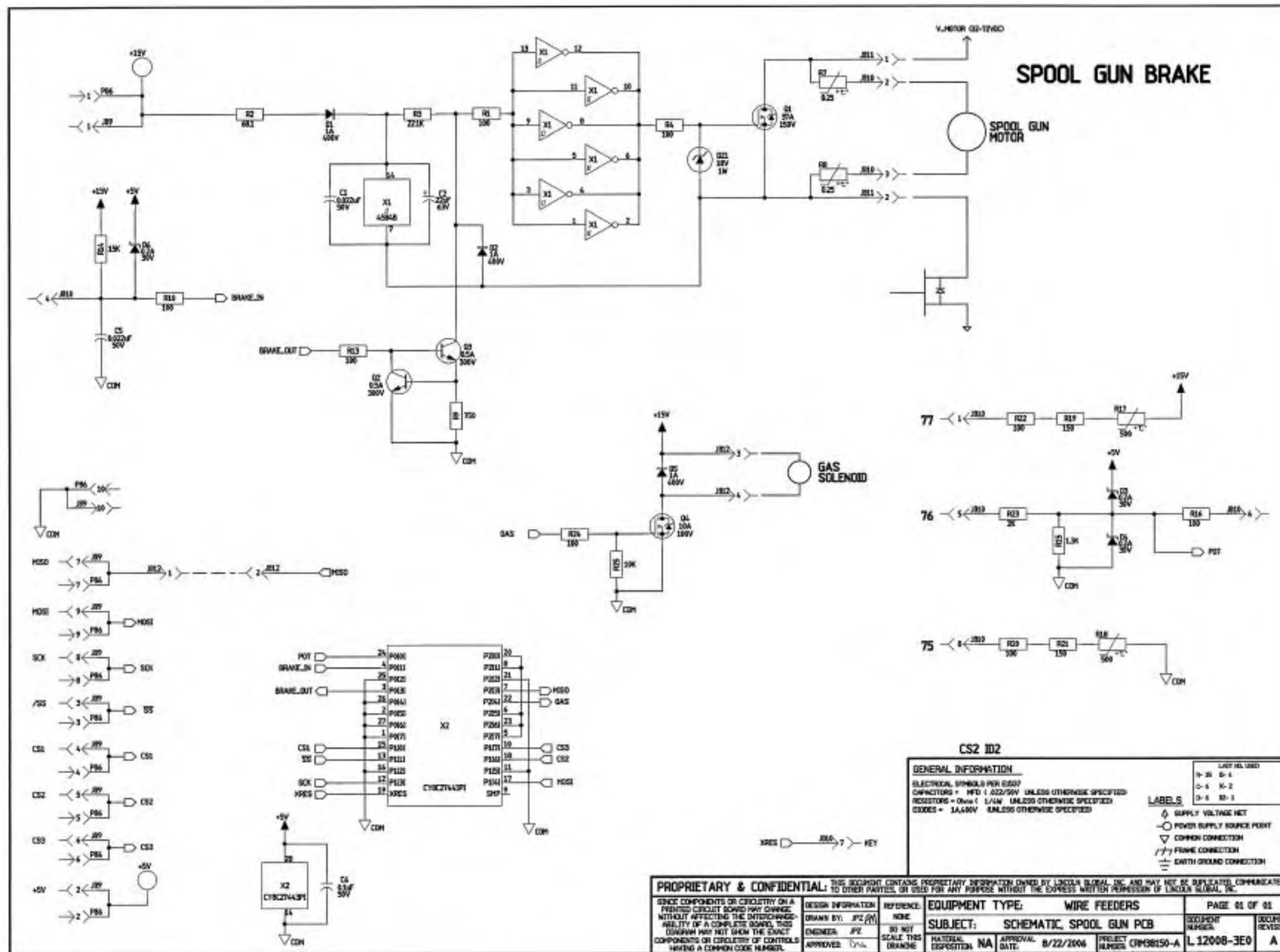

NOTE: Lincoln Electric assumes no responsibility for liabilities resulting from board level troubleshooting. PC Board repairs will invalidate your factory warranty. Individual Printed Circuit Board Components are not available from Lincoln Electric. This information is provided for reference only. Lincoln Electric discourages board level troubleshooting and repair since it may compromise the quality of the design and may result in danger to the Machine Operator or Technician. Improper PC board repairs could result in damage to the machine.



PC BOARD ASSEMBLY - SPOOL GUN - ALL CODES - (M20159-3)

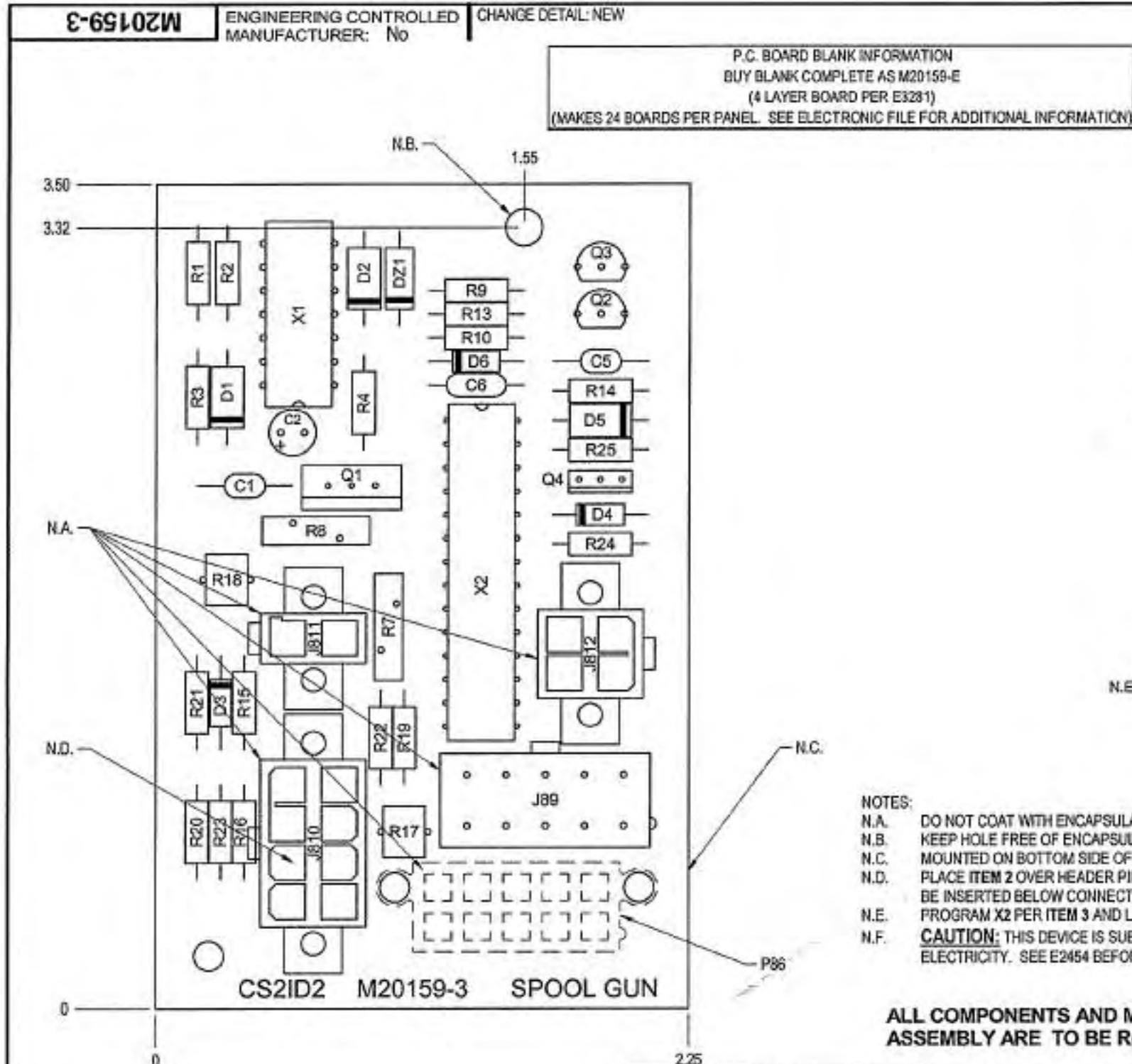

ITEM (USED WITH)*	QTY	PART NUMBER	DESCRIPTION
1	1	SEE BLANK INFO	PC BOARD BLANK
2 (J810-7)*	1	S24671	KEYING PAD
3 (Q2)*	1	Y00725-1	SOFTWARE
REFER TO ELECTRONIC COMPONENT DATABASE FOR SPECIFICATIONS ON ITEMS LISTED BELOW			
REFERENCES	QTY	PART NUMBER	DESCRIPTION
C1, C5	2	S16668-5	CAPACITOR,CEMO,.022,50V,20%
C2	1	S13490-181	CAPACITOR,ALEL,22,63V,20%
C6	1	S16668-11	CAPACITOR,CEMO,0.1, 50V,10%
D1, D2, D5	3	T12199-1	DIODE,AXLDS,1A,400V
D3, D4, D6	3	T12705-64	DIODE,SCHOTTKY,AXLDS,0.2A,30V,BAT42
DZ1	1	T12702-45	ZENER DIODE,1W,18V,5%,1N4746A
J89	1	S16248-10	CONNECTOR,MOLEX,MINI,PCB,10-PIN
J810	1	S24020-8	CONNECTOR,MOLEX,MINI,PCB,8-PIN,TIN
J811	1	S24020-2G	CONNECTOR,MOLEX,MINI,PCB,2-PIN,GOLD
J812	1	S24020-4	CONNECTOR,MOLEX,MINI,PCB,4-PIN,TIN
P86	1	S21135-10	CONNECTOR,MOLEX,MINI,BLIND,F,10-PIN
N.F. Q1	1	T12704-98	TRANSISTOR,NMF,TO220,37A,150V,FDP2552(SS)
N.F. Q2, Q3	2	T12704-35	TRANSISTOR,NPN,TO226,0.5A, 300V,MPS-A42
N.F. Q4	1	T12704-108	TRANSISTOR,NMF,IPAK,TO-251,10A,100V(SS)
R1, R4, R10, R13, R15, R20, R22, R24	8	S19400-1000	RESISTOR,MF,1/4W,100,1%
R2	1	S19400-68R1	RESISTOR,MF,1/4W,68.1,1%
R3	1	S19400-2212	RESISTOR,MF,1/4W,22.1K,1%
R7, R8	2	S18380-4	THERMISTOR,.02-.47 OHMS, 0.9AMP
R9	1	S19400-7500	RESISTOR,MF,1/4W,750,1%
R14	1	S19400-1502	RESISTOR,MF,1/4W,15.0K,1%
R15	1	S19400-1301	RESISTOR,MF,1/4W,1.30K,1%
R17, R18	2	S18380-14	THERMISTOR,PTC,500OHMS,28mA
R19, R21	2	S19400-1500	RESISTOR,MF,1/4W,150,1%
R23	1	S19400-2001	RESISTOR,MF,1/4W,2.00K,1%
R25	1	S19400-1002	RESISTOR,MF,1/4W,10.0K,1%
N.F. X1	1	S15018-4	IC,CMOS,INVERTER,SCHMITT, HEX,4584(SS)
N.E.,N.F. X2	1	S25073-9	IC,CMOS,PSOC,8-BIT,CY8C27443,DIP-28(SS)

UNLESS OTHERWISE SPECIFIED:
 CAPACITANCE = MFDVOLTS
 INDUCTANCE = HENRIES
 RESISTANCE = OHMS

- NOTES:
 N.A. DO NOT COAT WITH ENCAPSULATION MATERIAL.
 N.B. KEEP HOLE FREE OF ENCAPSULATION MATERIAL.
 N.C. MOUNTED ON BOTTOM SIDE OF P.C. BOARD.
 N.D. PLACE ITEM 2 OVER HEADER PIN AS SHOWN. ITEM 2 SHOULD BE INSERTED BELOW CONNECTOR TOP SURFACE.
 N.E. PROGRAM X2 PER ITEM 3 AND LABEL X2 WITH PART OF ITEM 3.
 N.F. **CAUTION:** THIS DEVICE IS SUBJECT TO DAMAGE BY STATIC ELECTRICITY. SEE E2454 BEFORE HANDLING.

MAKE PER E1911
 ENCAPSULATE WITH E1844 (2 DIPS)
 TEST PER E4190-SP

SCHEMATIC REFERENCE: L12008-3ED

MANUFACTURE AS:
M 2 0 1 5 9 - 3 E 0
 PART NUMBER IDENTIFICATION CODE

ALL COMPONENTS AND MATERIALS USED IN THIS ASSEMBLY ARE TO BE RoHS COMPLIANT PER E4253.

PROPRIETARY & CONFIDENTIAL THIS DOCUMENT CONTAINS PROPRIETARY INFORMATION OWNED BY LINCOLN GLOBAL, INC. AND MAY NOT BE DUPLICATED, COMMUNICATED TO OTHER PARTIES OR USED FOR ANY PURPOSE WITHOUT THE EXPRESS WRITTEN PERMISSION OF LINCOLN GLOBAL, INC.			
MANUFACTURING TOLERANCE PER E336 UNLESS OTHERWISE SPECIFIED TOLERANCE ON 2 PLACE DECIMALS IS ± .02 ON 3 PLACE DECIMALS IS ± .002 ON ALL ANGLES IS ± .5 OF A DEGREE MATERIAL TOLERANCE ("I") TO AGREE WITH PUBLISHED STANDARDS.	DESIGN INFORMATION DRAWN BY: FEI ENGINEER: APPROVED: DTL	REFERENCE: M20159-2 SCALE: 2:1	EQUIPMENT TYPE: POWER MIG 350MP SUBJECT: SPOOL GUN P. C. BOARD ASSEMBLY MATERIAL DISPOSITION: NA APPROVAL DATE: 08/22/2005 PROJECT NUMBER: CRM38150-A
DO NOT SCALE THIS DRAWING		PAGE 1 OF 1 DOCUMENT NUMBER: M20159-3 DOCUMENT REVISION: A	

NOTE: This diagram is for reference only. It may not be accurate for all machines covered by this manual.



SCHEMATIC - FILTER PC BOARD - ALL CODES - (M19487-2B0)

Return to Section TOC
Return to Master TOC

Return to Section TOC
Return to Master TOC

Return to Section TOC
Return to Master TOC

Return to Section TOC
Return to Master TOC

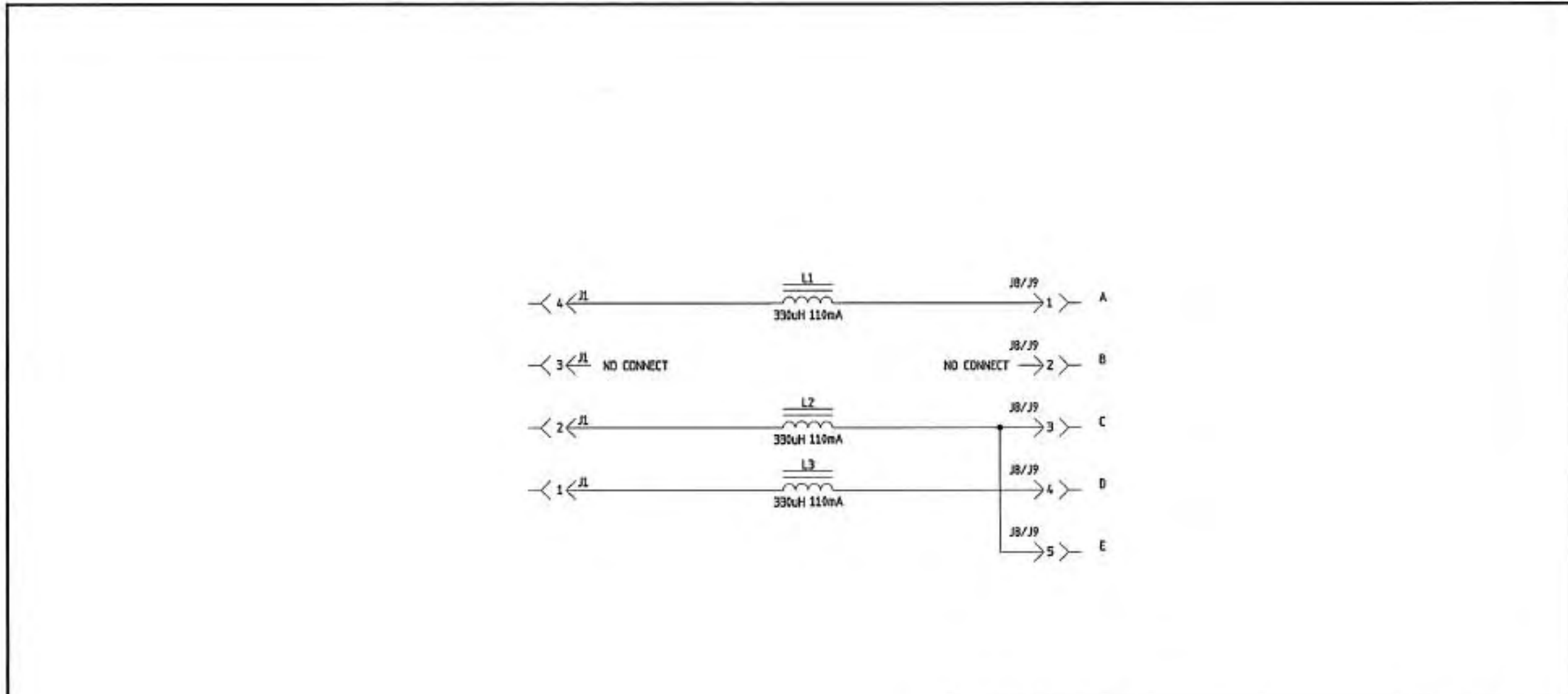

GENERAL INFORMATION

ELECTRICAL SYMBOLS PER E1537
 CAPACITORS = MFD (.022/50V UNLESS OTHERWISE SPECIFIED)
 RESISTORS = Ohms (1/4W UNLESS OTHERWISE SPECIFIED)
 COODES = 1A,400V UNLESS OTHERWISE SPECIFIED)

LAST NO. USED	
R -	L - 3
C -	
D -	

LABELS

- ▲ SUPPLY VOLTAGE NET
- POWER SUPPLY SOURCE POINT
- ▽ COMMON CONNECTION
- ⚡ FRAME CONNECTION
- ⊥ EARTH GROUND CONNECTION

PROPRIETARY & CONFIDENTIAL: THIS DOCUMENT CONTAINS PROPRIETARY INFORMATION OWNED BY LINCOLN GLOBAL, INC. AND MAY NOT BE DUPLICATED, COMMUNICATED TO OTHER PARTIES, OR USED FOR ANY PURPOSE WITHOUT THE EXPRESS WRITTEN PERMISSION OF LINCOLN GLOBAL, INC.

SINCE COMPONENTS OR CIRCUITRY ON A PRINTED CIRCUIT BOARD MAY CHANGE WITHOUT AFFECTING THE INTERCHANGEABILITY OF A COMPLETE BOARD, THIS DIAGRAM MAY NOT SHOW THE EXACT COMPONENTS OR CIRCUITRY OF CONTROLS HAVING A COMMON CODE NUMBER.	DESIGN INFORMATION	REFERENCE:	EQUIPMENT TYPE: WIRE FEEDERS		PAGE 01 OF 01	
	DRAWN BY: MJH/fm	-----	SUBJECT: SCHEMATIC, FILTER PCB		DOCUMENT NUMBER:	DOCUMENT REVISION:
	ENGINEER: NM	DO NOT SCALE THIS DRAWING	MATERIAL DISPOSITION: NA	APPROVAL DATE: 8/28/2006	PROJECT NUMBER: CRM36150-B	M19487-2B0
APPROVED: [Signature]						

NOTE: Lincoln Electric assumes no responsibility for liabilities resulting from board level troubleshooting. PC Board repairs will invalidate your factory warranty. **Individual Printed Circuit Board Components are not available from Lincoln Electric.** This information is provided for reference only. Lincoln Electric discourages board level troubleshooting and repair since it may compromise the quality of the design and may result in danger to the Machine Operator or Technician. Improper PC board repairs could result in damage to the machine.



