



NOTE: This manual will cover most of the troubleshooting and repair procedures for the code numbers listed. Some variances may exist when troubleshooting/repairing later code numbers.

VANTAGE® 500

For use with machines having Code Numbers:

**10995, 10996, 11180, 11181,
11415, 11416, 11468, 11931, 11960, 11932**

SERVICE MANUAL



Need Help? Call 1.888.935.3877
to talk to a Service Representative

Hours of Operation:
8:00 AM to 6:00 PM (ET) Mon. thru Fri.

After hours?
Use "Ask the Experts" at lincolnelectric.com
A Lincoln Service Representative will contact you
no later than the following business day.

For Service outside the USA:
Email: globalservice@lincolnelectric.com

⚠ WARNING

⚠ CALIFORNIA PROPOSITION 65 WARNINGS ⚠

Diesel engine exhaust and some of its constituents are known to the State of California to cause cancer, birth defects, and other reproductive harm.

The Above For Diesel Engines

The engine exhaust from this product contains chemicals known to the State of California to cause cancer, birth defects, or other reproductive harm.

The Above For Gasoline Engines

ARC WELDING can be hazardous. PROTECT YOURSELF AND OTHERS FROM POSSIBLE SERIOUS INJURY OR DEATH. KEEP CHILDREN AWAY. PACEMAKER WEARERS SHOULD CONSULT WITH THEIR DOCTOR BEFORE OPERATING.

Read and understand the following safety highlights. For additional safety information, it is strongly recommended that you purchase a copy of "Safety in Welding & Cutting - ANSI Standard Z49.1" from the American Welding Society, P.O. Box 351040, Miami, Florida 33135 or CSA Standard W117.2-1974. A Free copy of "Arc Welding Safety" booklet E205 is available from the Lincoln Electric Company, 22801 St. Clair Avenue, Cleveland, Ohio 44117-1199.

BE SURE THAT ALL INSTALLATION, OPERATION, MAINTENANCE AND REPAIR PROCEDURES ARE PERFORMED ONLY BY QUALIFIED INDIVIDUALS.



FOR ENGINE powered equipment.

1.a. Turn the engine off before troubleshooting and maintenance work unless the maintenance work requires it to be running.



1.b. Operate engines in open, well-ventilated areas or vent the engine exhaust fumes outdoors.



1.c. Do not add the fuel near an open flame welding arc or when the engine is running. Stop the engine and allow it to cool before refueling to prevent spilled fuel from vaporizing on contact with hot engine parts and igniting. Do not spill fuel when filling tank. If fuel is spilled, wipe it up and do not start engine until fumes have been eliminated.

1.d. Keep all equipment safety guards, covers and devices in position and in good repair. Keep hands, hair, clothing and tools away from V-belts, gears, fans and all other moving parts when starting, operating or repairing equipment.

1.e. In some cases it may be necessary to remove safety guards to perform required maintenance. Remove guards only when necessary and replace them when the maintenance requiring their removal is complete. Always use the greatest care when working near moving parts.



1.f. Do not put your hands near the engine fan. Do not attempt to override the governor or idler by pushing on the throttle control rods while the engine is running.

1.g. To prevent accidentally starting gasoline engines while turning the engine or welding generator during maintenance work, disconnect the spark plug wires, distributor cap or magneto wire as appropriate.

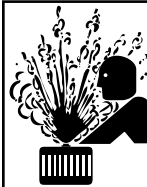

1.h. To avoid scalding, do not remove the radiator pressure cap when the engine is hot.



ELECTRIC AND MAGNETIC FIELDS may be dangerous

2.a. Electric current flowing through any conductor causes localized Electric and Magnetic Fields (EMF). Welding current creates EMF fields around welding cables and welding machines

2.b. EMF fields may interfere with some pacemakers, and welders having a pacemaker should consult their physician before welding.

2.c. Exposure to EMF fields in welding may have other health effects which are now not known.

2.d. All welders should use the following procedures in order to minimize exposure to EMF fields from the welding circuit:

2.d.1. Route the electrode and work cables together - Secure them with tape when possible.

2.d.2. Never coil the electrode lead around your body.

2.d.3. Do not place your body between the electrode and work cables. If the electrode cable is on your right side, the work cable should also be on your right side.

2.d.4. Connect the work cable to the workpiece as close as possible to the area being welded.

2.d.5. Do not work next to welding power source.



ELECTRIC SHOCK can kill.

3.a. The electrode and work (or ground) circuits are electrically “hot” when the welder is on. Do not touch these “hot” parts with your bare skin or wet clothing. Wear dry, hole-free gloves to insulate hands.

3.b. Insulate yourself from work and ground using dry insulation. Make certain the insulation is large enough to cover your full area of physical contact with work and ground.

In addition to the normal safety precautions, if welding must be performed under electrically hazardous conditions (in damp locations or while wearing wet clothing; on metal structures such as floors, gratings or scaffolds; when in cramped positions such as sitting, kneeling or lying, if there is a high risk of unavoidable or accidental contact with the workpiece or ground) use the following equipment:

- Semiautomatic DC Constant Voltage (Wire) Welder.
- DC Manual (Stick) Welder.
- AC Welder with Reduced Voltage Control.

3.c. In semiautomatic or automatic wire welding, the electrode, electrode reel, welding head, nozzle or semiautomatic welding gun are also electrically “hot”.

3.d. Always be sure the work cable makes a good electrical connection with the metal being welded. The connection should be as close as possible to the area being welded.

3.e. Ground the work or metal to be welded to a good electrical (earth) ground.

3.f. Maintain the electrode holder, work clamp, welding cable and welding machine in good, safe operating condition. Replace damaged insulation.

3.g. Never dip the electrode in water for cooling.

3.h. Never simultaneously touch electrically “hot” parts of electrode holders connected to two welders because voltage between the two can be the total of the open circuit voltage of both welders.

3.i. When working above floor level, use a safety belt to protect yourself from a fall should you get a shock.

3.j. Also see Items 6.c. and 8.



ARC RAYS can burn.

4.a. Use a shield with the proper filter and cover plates to protect your eyes from sparks and the rays of the arc when welding or observing open arc welding. Headshield and filter lens should conform to ANSI Z87.1 standards.

4.b. Use suitable clothing made from durable flame-resistant material to protect your skin and that of your helpers from the arc rays.

4.c. Protect other nearby personnel with suitable, non-flammable screening and/or warn them not to watch the arc nor expose themselves to the arc rays or to hot spatter or metal.



FUMES AND GASES can be dangerous.

5.a. Welding may produce fumes and gases hazardous to health. Avoid breathing these fumes and gases. When welding, keep your head out of the fume. Use enough ventilation and/or exhaust at the arc to keep fumes and gases away from the breathing zone. **When welding with electrodes which require special ventilation such as stainless or hard facing (see instructions on container or MSDS) or on lead or cadmium plated steel and other metals or coatings which produce highly toxic fumes, keep exposure as low as possible and within applicable OSHA PEL and ACGIH TLV limits using local exhaust or mechanical ventilation. In confined spaces or in some circumstances, outdoors, a respirator may be required. Additional precautions are also required when welding on galvanized steel.**

5.b. The operation of welding fume control equipment is affected by various factors including proper use and positioning of the equipment, maintenance of the equipment and the specific welding procedure and application involved. Worker exposure level should be checked upon installation and periodically thereafter to be certain it is within applicable OSHA PEL and ACGIH TLV limits.

5.c. Do not weld in locations near chlorinated hydrocarbon vapors coming from degreasing, cleaning or spraying operations. The heat and rays of the arc can react with solvent vapors to form phosgene, a highly toxic gas, and other irritating products.

5.d. Shielding gases used for arc welding can displace air and cause injury or death. Always use enough ventilation, especially in confined areas, to insure breathing air is safe.

5.e. Read and understand the manufacturer’s instructions for this equipment and the consumables to be used, including the material safety data sheet (MSDS) and follow your employer’s safety practices. MSDS forms are available from your welding distributor or from the manufacturer.

5.f. Also see item 1.b.

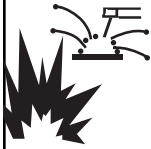

WELDING and CUTTING SPARKS can cause fire or explosion.

6.a. Remove fire hazards from the welding area. If this is not possible, cover them to prevent the welding sparks from starting a fire. Remember that welding sparks and hot materials from welding can easily go through small cracks and openings to adjacent areas. Avoid welding near hydraulic lines. Have a fire extinguisher readily available.

- 6.b. Where compressed gases are to be used at the job site, special precautions should be used to prevent hazardous situations. Refer to "Safety in Welding and Cutting" (ANSI Standard Z49.1) and the operating information for the equipment being used.
- 6.c. When not welding, make certain no part of the electrode circuit is touching the work or ground. Accidental contact can cause overheating and create a fire hazard.
- 6.d. Do not heat, cut or weld tanks, drums or containers until the proper steps have been taken to insure that such procedures will not cause flammable or toxic vapors from substances inside. They can cause an explosion even though they have been "cleaned". For information, purchase "Recommended Safe Practices for the Preparation for Welding and Cutting of Containers and Piping That Have Held Hazardous Substances", AWS F4.1 from the American Welding Society (see address above).
- 6.e. Vent hollow castings or containers before heating, cutting or welding. They may explode.
- 6.f. Sparks and spatter are thrown from the welding arc. Wear oil free protective garments such as leather gloves, heavy shirt, cuffless trousers, high shoes and a cap over your hair. Wear ear plugs when welding out of position or in confined places. Always wear safety glasses with side shields when in a welding area.
- 6.g. Connect the work cable to the work as close to the welding area as practical. Work cables connected to the building framework or other locations away from the welding area increase the possibility of the welding current passing through lifting chains, crane cables or other alternate circuits. This can create fire hazards or overheat lifting chains or cables until they fail.
- 6.h. Also see item 1.c.
- 6.i. Read and follow NFPA 51B "Standard for Fire Prevention During Welding, Cutting and Other Hot Work", available from NFPA, 1 Batterymarch Park, PO box 9101, Quincy, Ma 022690-9101.
- 6.j. Do not use a welding power source for pipe thawing.



CYLINDER may explode if damaged.

- 7.a. Use only compressed gas cylinders containing the correct shielding gas for the process used and properly operating regulators designed for the gas and pressure used. All hoses, fittings, etc. should be suitable for the application and maintained in good condition.
- 7.b. Always keep cylinders in an upright position securely chained to an undercarriage or fixed support.
- 7.c. Cylinders should be located:
 - Away from areas where they may be struck or subjected to physical damage.
 - A safe distance from arc welding or cutting operations and any other source of heat, sparks, or flame.
- 7.d. Never allow the electrode, electrode holder or any other electrically "hot" parts to touch a cylinder.
- 7.e. Keep your head and face away from the cylinder valve outlet when opening the cylinder valve.
- 7.f. Valve protection caps should always be in place and hand tight except when the cylinder is in use or connected for use.
- 7.g. Read and follow the instructions on compressed gas cylinders, associated equipment, and CGA publication P-1, "Precautions for Safe Handling of Compressed Gases in Cylinders," available from the Compressed Gas Association 1235 Jefferson Davis Highway, Arlington, VA 22202.



FOR ELECTRICALLY powered equipment.

- 8.a. Turn off input power using the disconnect switch at the fuse box before working on the equipment.
- 8.b. Install equipment in accordance with the U.S. National Electrical Code, all local codes and the manufacturer's recommendations.
- 8.c. Ground the equipment in accordance with the U.S. National Electrical Code and the manufacturer's recommendations.

Refer to <http://www.lincolnelectric.com/safety> for additional safety information.

PRÉCAUTIONS DE SÛRETÉ

Pour votre propre protection lire et observer toutes les instructions et les précautions de sûreté spécifiques qui paraissent dans ce manuel aussi bien que les précautions de sûreté générales suivantes:

Sûreté Pour Soudage A L'Arc

1. Protégez-vous contre la secousse électrique:
 - a. Les circuits à l'électrode et à la pièce sont sous tension quand la machine à souder est en marche. Eviter toujours tout contact entre les parties sous tension et la peau nue ou les vêtements mouillés. Porter des gants secs et sans trous pour isoler les mains.
 - b. Faire très attention de bien s'isoler de la masse quand on soude dans des endroits humides, ou sur un plancher métallique ou des grilles métalliques, principalement dans les positions assis ou couché pour lesquelles une grande partie du corps peut être en contact avec la masse.
 - c. Maintenir le porte-électrode, la pince de masse, le câble de soudage et la machine à souder en bon et sûr état de fonctionnement.
 - d. Ne jamais plonger le porte-électrode dans l'eau pour le refroidir.
 - e. Ne jamais toucher simultanément les parties sous tension des porte-électrodes connectés à deux machines à souder parce que la tension entre les deux pinces peut être le total de la tension à vide des deux machines.
 - f. Si on utilise la machine à souder comme une source de courant pour soudage semi-automatique, ces précautions pour le porte-électrode s'appliquent aussi au pistolet de soudage.
2. Dans le cas de travail au dessus du niveau du sol, se protéger contre les chutes dans le cas où on reçoit un choc. Ne jamais enrouler le câble-électrode autour de n'importe quelle partie du corps.
3. Un coup d'arc peut être plus sévère qu'un coup de soliel, donc:
 - a. Utiliser un bon masque avec un verre filtrant approprié ainsi qu'un verre blanc afin de se protéger les yeux du rayonnement de l'arc et des projections quand on soude ou quand on regarde l'arc.
 - b. Porter des vêtements convenables afin de protéger la peau de soudeur et des aides contre le rayonnement de l'arc.
 - c. Protéger l'autre personnel travaillant à proximité au soudage à l'aide d'écrans appropriés et non-inflammables.
4. Des gouttes de laitier en fusion sont émises de l'arc de soudage. Se protéger avec des vêtements de protection libres de l'huile, tels que les gants en cuir, chemise épaisse, pantalons sans revers, et chaussures montantes.
5. Toujours porter des lunettes de sécurité dans la zone de soudage. Utiliser des lunettes avec écrans latéraux dans les zones où l'on pique le laitier.

6. Eloigner les matériaux inflammables ou les recouvrir afin de prévenir tout risque d'incendie dû aux étincelles.
7. Quand on ne soude pas, poser la pince à un endroit isolé de la masse. Un court-circuit accidentel peut provoquer un échauffement et un risque d'incendie.
8. S'assurer que la masse est connectée le plus près possible de la zone de travail qu'il est pratique de le faire. Si on place la masse sur la charpente de la construction ou d'autres endroits éloignés de la zone de travail, on augmente le risque de voir passer le courant de soudage par les chaînes de levage, câbles de grue, ou autres circuits. Cela peut provoquer des risques d'incendie ou d'échauffement des chaînes et des câbles jusqu'à ce qu'ils se rompent.
9. Assurer une ventilation suffisante dans la zone de soudage. Ceci est particulièrement important pour le soudage de tôles galvanisées plombées, ou cadmiées ou tout autre métal qui produit des fumées toxiques.
10. Ne pas souder en présence de vapeurs de chlore provenant d'opérations de dégraissage, nettoyage ou pistolage. La chaleur ou les rayons de l'arc peuvent réagir avec les vapeurs du solvant pour produire du phosgène (gas fortement toxique) ou autres produits irritants.
11. Pour obtenir de plus amples renseignements sur la sûreté, voir le code "Code for safety in welding and cutting" CSA Standard W 117.2-1974.

PRÉCAUTIONS DE SÛRETÉ POUR LES MACHINES À SOUDER À TRANSFORMATEUR ET À REDRESSEUR

1. Relier à la terre le châssis du poste conformément au code de l'électricité et aux recommandations du fabricant. Le dispositif de montage ou la pièce à souder doit être branché à une bonne mise à la terre.
2. Autant que possible, l'installation et l'entretien du poste seront effectués par un électricien qualifié.
3. Avant de faire des travaux à l'intérieur de poste, la débrancher à l'interrupteur à la boîte de fusibles.
4. Garder tous les couvercles et dispositifs de sûreté à leur place.

Electromagnetic Compatibility (EMC)

Conformance

Products displaying the CE mark are in conformity with European Community Council Directive of 15 Dec 2004 on the approximation of the laws of the Member States relating to electromagnetic compatibility, 2004/108/EC. It was manufactured in conformity with a national standard that implements a harmonized standard: EN 60974-10 Electromagnetic Compatibility (EMC) Product Standard for Arc Welding Equipment. It is for use with other Lincoln Electric equipment. It is designed for industrial and professional use.

Introduction

All electrical equipment generates small amounts of electromagnetic emission. Electrical emission may be transmitted through power lines or radiated through space, similar to a radio transmitter. When emissions are received by other equipment, electrical interference may result. Electrical emissions may affect many kinds of electrical equipment; other nearby welding equipment, radio and TV reception, numerical controlled machines, telephone systems, computers, etc. Be aware that interference may result and extra precautions may be required when a welding power source is used in a domestic establishment.

Installation and Use

The user is responsible for installing and using the welding equipment according to the manufacturer's instructions. If electromagnetic disturbances are detected then it shall be the responsibility of the user of the welding equipment to resolve the situation with the technical assistance of the manufacturer. In some cases this remedial action may be as simple as earthing (grounding) the welding circuit, see Note. In other cases it could involve construction of an electromagnetic screen enclosing the power source and the work complete with associated input filters. In all cases electromagnetic disturbances must be reduced to the point where they are no longer troublesome.

Note: The welding circuit may or may not be earthed for safety reasons according to national codes. Changing the earthing arrangements should only be authorized by a person who is competent to access whether the changes will increase the risk of injury, e.g., by allowing parallel welding current return paths which may damage the earth circuits of other equipment.

Assessment of Area

Before installing welding equipment the user shall make an assessment of potential electromagnetic problems in the surrounding area. The following shall be taken into account:

- a) other supply cables, control cables, signaling and telephone cables; above, below and adjacent to the welding equipment;
- b) radio and television transmitters and receivers;
- c) computer and other control equipment;
- d) safety critical equipment, e.g., guarding of industrial equipment;
- e) the health of the people around, e.g., the use of pacemakers and hearing aids;
- f) equipment used for calibration or measurement
- g) the immunity of other equipment in the environment. The user shall ensure that other equipment being used in the environment is compatible. This may require additional protection measures;
- h) the time of day that welding or other activities are to be carried out.

Electromagnetic Compatibility (EMC)

The size of the surrounding area to be considered will depend on the structure of the building and other activities that are taking place. The surrounding area may extend beyond the boundaries of the premises.

Methods of Reducing Emissions

Mains Supply

Welding equipment should be connected to the mains supply according to the manufacturer's recommendations. If interference occurs, it may be necessary to take additional precautions such as filtering of the mains supply. Consideration should be given to shielding the supply cable of permanently installed welding equipment, in metallic conduit or equivalent. Shielding should be electrically continuous throughout its length. The shielding should be connected to the welding power source so that good electrical contact is maintained between the conduit and the welding power source enclosure.

Maintenance of the Welding Equipment

The welding equipment should be routinely maintained according to the manufacturer's recommendations. All access and service doors and covers should be closed and properly fastened when the welding equipment is in operation. The welding equipment should not be modified in any way except for those changes and adjustments covered in the manufacturer's instructions. In particular, the spark gaps of arc striking and stabilizing devices should be adjusted and maintained according to the manufacturer's recommendations.

Welding Cables

The welding cables should be kept as short as possible and should be positioned close together, running at or close to floor level.

Equipotential Bonding

Bonding of all metallic components in the welding installation and adjacent to it should be considered. However, metallic components bonded to the work piece will increase the risk that the operator could receive a shock by touching these metallic components and the electrode at the same time. The operator should be insulated from all such bonded metallic components.

Earthing of the Workpiece

Where the workpiece is not bonded to earth for electrical safety, not connected to earth because of its size and position, e.g., ships hull or building steelwork, a connection bonding the workpiece to earth may reduce emissions in some, but not all instances. Care should be taken to prevent the earthing of the workpiece increasing the risk of injury to users, or damage to other electrical equipment. Where necessary, the connection of the workpiece to earth should be made by a direct connection to the workpiece, but in some countries where direct connection is not permitted, the bonding should be achieved by suitable capacitance, selected according to national regulations.

Screening and Shielding

Selective screening and shielding of other cables and equipment in the surrounding area may alleviate problems of interference. Screening of the entire welding installation may be considered for special applications.¹

¹ Portions of the preceding text are contained in EN 60974-10: "Electromagnetic Compatibility (EMC) product standard for arc welding equipment."

- MASTER TABLE OF CONTENTS FOR ALL SECTIONS -

Page

Safetyi-iv
<hr/>	
Installation	Section A
VANTAGE® 500 Deutz F3L912 (Code 10995)	A1
VANTAGE® 500 Deutz F4L2011 (Code 11180, 11415)	A2
VANTAGE® 500 Deutz D2011L4i (Code 11468)	A3
VANTAGE® 500 Cummins B3.3 (Code 10996)	A4
VANTAGE® 500 Cummins B3.3 (Code 11181, 11416)	A5
<hr/>	
Operation	Section B
<hr/>	
VANTAGE® 500 Deutz F3L912 (Code 10995)	B1
VANTAGE® 500 Deutz F4L2011 (Code 11180, 11415)	B2
VANTAGE® 500 Deutz D2011L4i (Code 11468)	B3
VANTAGE® 500 Cummins B3.3 (Code 10996)	B4
VANTAGE® 500 Cummins B3.3 (Code 11181, 11416)	B5
<hr/>	
Accessories	Section C
VANTAGE® 500 Deutz F3L912 (Code 10995)	C1
VANTAGE® 500 Deutz F4L2011 (Code 11180, 11415)	C2
VANTAGE® 500 Deutz D2011L4i (Code 11468)	C3
VANTAGE® 500 Cummins B3.3 (Code 10996)	C4
VANTAGE® 500 Cummins B3.3 (Code 11181, 11416)	C5
<hr/>	
Maintenance	Section D
VANTAGE® 500 Deutz F3L912 (Code 10995)	D1
VANTAGE® 500 Deutz F4L2011 (Code 11180, 11415)	D2
VANTAGE® 500 Deutz D2011L4i (Code 11468)	D3
VANTAGE® 500 Cummins B3.3 (Code 10996)	D4
VANTAGE® 500 Cummins B3.3 (Code 11181, 11416)	D5
<hr/>	
Theory of Operation	Section E
<hr/>	
Troubleshooting and Repair	Section F
<hr/>	
Electrical Diagrams	Section G
<hr/>	
Parts Lists	P-472, P-508
VANTAGE® 500 Deutz F3L912 (Code 10995)	P-472
VANTAGE® 500 Deutz F4L2011 (Code 11180, 11415)	P-508
VANTAGE® 500 Deutz D2011L4i (Code 11468)	P-508
VANTAGE® 500 Cummins B3.3 (Code 10996)	P-472
VANTAGE® 500 Cummins B3.3 (Code 11181, 11416)	P-508

VANTAGE® 500



Installation - VANTAGE® 500 Deutz F3L912 (Code 10995)

Technical Specifications	A1.2
Safety Precautions	A1.3
Location/Ventilation	A1.3
Storing	A1.3
Stacking	A1.3
Angle of Operation	A1.3
Lifting	A1.4
High Altitude Operation	A1.4
High Temperature Operation	A1.4
Towing	A1.4
Vehicle Mounting	A1.4
Pre-Operation Engine Service	A1.5
Oil	A1.5
Fuel	A1.5
Fuel Cap	A1.5
Engine Cooling System	A1.5
Battery Connection	A1.5
Muffler Outlet Pipe	A1.6
Spark Arrester	A1.6
High Frequency Generators for TIG Applications	A1.6
Electrical Connections	A1.6
Remote Control	A1.6
Welding Terminals	A1.6
Welding Output Cables	A1.7
Machine Grounding	A1.7
Auxiliary Power Receptacles	A1.7
Standby Power Connections	A1.7

TECHNICAL SPECIFICATIONS - Vantage 500® DEUTZ (K2271-1)

INPUT - DIESEL ENGINE					
Make /Model	Description	Speed (RPM)	Displacement	Starting System	Capacities
Deutz F3L 912 Diesel Engine Code 10995	3 cylinder 44HP (33 kw) @ 1800 RPM	High Idle 1900 Full Load 1800	173 cu. in (2.83L) Bore x Stroke 3.94" x 4.72" (100mm x 120mm)	12VDC battery & Starter	Fuel (25 US gal 94.6L) Oil: 9.5 QTS. 9.0L
RATED OUTPUT @ 104°F(40°C) - WELDER					
Duty Cycle	Welding Output		Volts at Rated Amps		
100%	500 Amps (DC multi-purpose)		40 Volts		
60%	550 Amps (DC multi-purpose)		36 volts		
50%	575 Amps (DC multi-purpose)		35 volts		
OUTPUT @ 104°F(40°C) - WELDER AND GENERATOR					
Welding Range 30 - 575 Amps CC/CV 20 - 250 Amps TIG					
Open Circuit Voltage 60 Max OCV @ 1900 RPM					
Auxiliary Power ⁽¹⁾ 120/240 VAC 12,000 WATTS, 60 Hz.					
PHYSICAL DIMENSIONS					
Height ⁽²⁾	Width	Depth	Weight		
42.0 in (1066.8 mm)	31.5 in. (800.1mm)	63.1 in. (1603mm)	1615 lbs. (733kg) (Approx)		

- Output rating in watts is equivalent to volt-amperes at unity power factor.
Output voltage is within +/- 10% at all loads up to rated capacity. When welding, available auxiliary power will be reduced.
- Top of Enclosure. Add 6.6" (167.6mm) for exhaust.

VANTAGE® 500

Read this entire installation section before you start installation.

SAFETY PRECAUTIONS



WARNING

Do not attempt to use this equipment until you have thoroughly read all operating and maintenance manuals supplied with your machine. They include important safety precautions, detailed engine starting, operating and maintenance instructions and parts lists.

ELECTRIC SHOCK can kill.



- Do not touch electrically live parts such as output terminals or internal wiring.
- Insulate yourself from the work and ground.
- Always wear dry insulating gloves.

ENGINE EXHAUST can kill.



- Use in open, well ventilated areas or vent exhaust outside
- Do not stack anything near the engine.

MOVING PARTS can injure.



- Do not operate with doors open or guards off.
- Stop engine before servicing.
- Keep away from moving parts

Only qualified personnel should install, use or service this equipment

LOCATION / VENTILATION

The welder should be located to provide an unrestricted flow of clean, cool air to the cooling air inlets and to avoid restricting the cooling air outlets. Also, locate the welder so that the engine exhaust fumes are properly vented to an outside area.



CAUTION

DO NOT MOUNT OVER COMBUSTIBLE SURFACES

Where there is a combustible surface directly under stationary or fixed electrical equipment, that surface should be covered with a steel plate at least .06”(1.6mm) thick, which should extend not less than 5.90”(150mm) beyond the equipment on all sides.

STORING

1. Store the machine in a cool, dry place when it is not in use. Protect it from dust and dirt. Keep it where it can't be accidentally damaged from construction activities, moving vehicles, and other hazards.
2. Drain the engine oil and refill with fresh 10W30 oil. Run the engine for about five minutes to circulate oil to all the parts. See the **MAINTENANCE** section of this manual for details on changing oil.
3. Remove the battery, recharge it, and adjust the electrolyte level. Store the battery in a dry, dark place.

STACKING

Vantage 500 machines cannot be stacked.

ANGLE OF OPERATION

To achieve optimum engine performance the Vantage should be run in a level position. The maximum angle of operation for the Cummins engine is 35 degrees in all directions. If the engine is to be operated at an angle, provisions must be made for checking and maintaining the oil level at the normal (FULL) oil capacity in the crankcase. When operating the welder at an angle, the effective fuel capacity will be slightly less than the specified 25 gallons.

LIFTING

The Vantage® 500 lift bale should be used to lift the machine. The Vantage® 500 is shipped with the lift bale retracted. Before attempting to lift the Vantage® 500, secure the lift bale in a raised position. Secure the lift bale as follows:

- Open the engine compartment door.
- Locate the two access holes on the upper middle region of the compartment wall just below the lift bale.
- Use the lifting strap to raise the lift bale to the full upright position. This will align the mounting holes on the lift bale with the access holes.
- Secure the lift bale with 2 thread forming screws. The screws are provided in the loose parts bag shipped with the machine.

WARNING



FALLING EQUIPMENT can cause injury.

- **Do not lift this machine using lift bale if it is equipped with a heavy accessory such as a trailer or gas cylinder.**
- **Lift only with equipment of adequate lifting capacity.**
- **Be sure machine is stable when lifting.**

HIGH ALTITUDE OPERATION

At higher altitude, output derating may be necessary. For maximum rating, derate the welder output 5% for every 300 meters (984 ft.) above 1500 meters (4920 ft.). For output of 500A and below, derate the welder output 5% for every 300 meters (984 ft.) above 2100 meters (6888 ft.)

Contact a Deutz Service Representative for any engine adjustments that may be required.

HIGH TEMPERATURE OPERATION

At temperatures above 30°C (86°F), output voltage derating is necessary. For maximum output current ratings, derate the welder voltage rating two volts for every 10°C (21°F) above 30°C (86°F).

TOWING

The recommended trailer for use with this equipment for road, in-plant and yard towing by a vehicle¹ is Lincoln's K2636-1. If the user adapts a non-Lincoln trailer, he must assume responsibility that the method of attachment and usage does not result in a safety hazard nor damage the welding equipment. Some of the factors to be considered are as follows:

- Design capacity of the trailer vs. weight of the Lincoln equipment and likely additional attachments.
- Proper support of, and attachment to, the base of the welding equipment so that there will be no undue stress to the trailer's framework.
- Proper placement of the equipment on the trailer to insure stability side to side and front to back when being moved and when standing by itself.
- Typical conditions of use, such as travel speed, roughness of surface on which the trailer will be operated, and environmental conditions.
- Proper preventative maintenance of the trailer.
- Conformance with federal, state and local laws.¹

¹Consult applicable federal, state and local laws regarding specific requirements for use on public highways.

VEHICLE MOUNTING

WARNING

Improperly mounted concentrated loads may cause unstable vehicle handling and tires or other components to fail.

- **Only transport this Equipment on serviceable vehicles which are rated and designed for such loads.**
- **Distribute, balance and secure loads so vehicle is stable under conditions of use.**
- **Do not exceed maximum rated loads for components such as suspension, axles and tires.**
- **Mount equipment base to metal bed or frame of vehicle.**
- **Follow vehicle manufacturer's instructions.**

PRE-OPERATION ENGINE SERVICE

READ the engine operating and maintenance instructions supplied with this machine.

WARNING



- Keep hands away from the engine muffler or HOT engine parts.
- Stop engine and allow to cool before fueling.

- Do not smoke when fueling.
- Fill fuel tank at a moderate rate and do not over-fill.
- Wipe up spilled fuel and allow fumes to clear before starting engine.
- Keep sparks and flame away from tank.

OIL

The Vantage®500 is shipped with the engine crankcase filled with high quality SAE 10W-30 oil (API class CD or better). Check the oil level before starting the engine. If it is not up to the full mark on the dip stick, add oil as required. Check the oil level every four hours of running time during the first 35 running hours. Refer to the engine Operator's Manual for specific oil recommendations and break-in information. The oil change interval is dependent on the quality of the oil and the operating environment. Refer to the engine Operator's Manual for the proper service and maintenance intervals.



FUEL

NOTE: USE DIESEL FUEL ONLY.

Fill the fuel tank with clean, fresh diesel fuel. The capacity of the fuel tank is approx 95 liters. See engine Operator's Manual for specific fuel recommendations. **Running out of fuel may require bleeding the fuel injection pump.**

NOTE: Before starting the engine, open the fuel shut-off valve (pointer to be in line with hose).

FUEL CAP

Remove the plastic cap covering from the fuel tank filler neck and install the fuel cap.

ENGINE COOLING SYSTEM

The Deutz engine is air cooled by a belt-driven axial blower. The oil cooler and engine cooling fins should be blown out with compressed air or steam to maintain proper cooling. (See the engine Operator's Manual for procedures and frequency.)

BATTERY CONNECTION

WARNING



GASES FROM BATTERY can explode.

- Keep sparks, flame and cigarettes away from battery.

To prevent EXPLOSION when:

- **INSTALLING A NEW BATTERY** — disconnect negative cable from old battery first and connect to new battery last.
- **CONNECTING A BATTERY CHARGER** — remove battery from welder by disconnecting negative cable first, then positive cable and battery clamp. When reinstalling, connect negative cable last. Keep well ventilated.
- **USING A BOOSTER** — connect positive lead to battery first then connect negative lead to negative battery lead at engine foot.

BATTERY ACID can burn eyes and skin.



- Wear gloves and eye protection and be careful when working near battery.
- Follow instructions printed on battery.

IMPORTANT: To prevent ELECTRICAL DAMAGE WHEN:

- a) Installing new batteries
- b) Using a booster

Use correct polarity — **Negative Ground.**

The Vantage® 500 is shipped with the negative battery cable disconnected. Before you operate the machine, make sure the Engine Switch is in the OFF position and attach the disconnected cable securely to the negative (-) battery terminal.

Remove the insulating cap from the negative battery terminal. Replace and tighten the negative battery cable terminal.

NOTE: This machine is furnished with a wet charged battery; if unused for several months, the battery may require a booster charge. Be sure to use the correct polarity when charging the battery.

MUFFLER OUTLET PIPE

Remove the plastic plug covering the muffler outlet tube. Using the clamp provided, secure the outlet pipe to the outlet tube with the pipe positioned to direct the exhaust in the desired direction.

SPARK ARRESTER

Some federal, state or local laws may require that gasoline or diesel engines be equipped with exhaust spark arresters when they are operated in certain locations where unarrested sparks may present a fire hazard. The standard muffler included with this welder does not qualify as a spark arrester. When required by local regulations, a suitable spark arrester must be installed and properly maintained.

CAUTION

An incorrect arrester may lead to damage to the engine or adversely affect performance.

HIGH FREQUENCY GENERATORS FOR TIG APPLICATIONS

The K799 Hi-Freq Unit (obsolete) and the K930-1 or-2 TIG Module are suitable for use with the Vantage® 500. The Vantage 500 is equipped with the required R.F. bypass circuitry for the connection of high frequency generating equipment. The high frequency bypass network supplied with the K799 Hi-Freq Unit does NOT need to be installed into the Vantage 500.

The Vantage® 500 and any high frequency generating equipment must be properly grounded. See the K799 Hi-Freq Unit and the K930-1 or-2 TIG Module operating manuals for complete instructions on installation, operation, and maintenance.

ELECTRICAL CONNECTIONS

REMOTE CONTROL

The Vantage® 500 is equipped with a 6-pin and a 14-pin connector. The 6-pin connector is for connecting the K857 or K857-1 Remote Control (optional) or, in the case of TIG welding applications, with the foot or hand Amptrol (K870 or K963-1 respectively).

The 14-pin connector is used to directly connect a wire feeder or TIG Module (K930-1 or-2) control cable.

NOTE: When using the 14-pin connector, if the wire feeder has a built-in power source output control, do not connect anything to the 6-pin connector.

WELDING TERMINALS

The Vantage® 500 is equipped with a toggle switch for selecting "hot" welding terminals when in the "WELD TERMINALS ON" position or "cold" welding terminals when in the "WELDING TERMINALS REMOTELY CONTROLLED" position.

WELDING OUTPUT CABLES

With the engine off, route the electrode and work cables through the strain relief bracket provided on the front of the base and connect to the terminals provided. These connections should be checked periodically and tightened if necessary.

Listed in Table A1.1 are copper cable sizes recommended for the rated current and duty cycle. Lengths stipulated are the distance from the welder to work and back to the welder again. Cable sizes are increased for greater lengths primarily for the purpose of minimizing cable voltage drop.

TABLE A1.1 – COMBINED LENGTH OF ELECTRODE AND WORK CABLES

Amps @ 100% Duty Cycle	Total Combined Length of Electrode and Work Cables		
	Up to 150 ft.	150-200 ft.	200-250 ft.
500	3/0 AWG	3/0 AWG	4/0 AWG

MACHINE GROUNDING

Because this portable engine driven welder creates its own power, it is not necessary to connect its frame to an earth ground, unless the machine is connected to premises wiring (home, shop, etc.).

To prevent dangerous electric shock, other equipment powered by this engine driven welder must:

- a) be grounded to the frame of the welder using a grounded type plug,
or
- b) be double insulated.

When this welder is mounted on a truck or trailer, its frame must be securely connected to the metal frame of the vehicle. When this engine driven welder is connected to premises wiring such as that in a home or shop, its frame must be connected to the system earth ground. See further connection instructions in the section entitled **Standby Power Connections** as well as the article on grounding in the latest U.S. National Electrical Code and the local code.

In general, if the machine is to be grounded, it should be connected with a #8 or larger copper wire to a solid earth ground such as a metal water pipe going into the ground for at least ten feet and having no insulated joints, or to the metal framework of a building which has been effectively grounded. The U.S. National Electrical Code lists a number of alternate means of grounding electrical equipment. A machine grounding stud marked with the  symbol is provided on the front of the welder.

AUXILIARY POWER RECEPTACLES

The auxiliary power capacity of the Vantage® 500 is 12,000 watts of 60 Hz, single-phase power. The auxiliary power capacity rating in watts is equivalent to volt-amperes at unity power factor. The maximum permissible current of the 240 VAC output is 50 A. The 240 VAC output can be split to provide two separate 120 VAC outputs with a maximum permissible current of 50 A per output to two separate 120 VAC branch circuits. The output voltage is within $\pm 10\%$ at all loads up to rated capacity.

NOTE: The 120/240V receptacle has two 120V outlets of different phases and cannot be paralleled.

The Vantage® 500 has two 20A-120VAC (5-20R) duplex receptacles and one 50A-120/240 VAC (14-50R) receptacle. The 120/240 VAC receptacle can be split for single-phase 120 VAC operation. The auxiliary power receptacles should only be used with three-wire grounded type plugs or approved double insulated tools with two-wire plugs. The current rating of any plug used with the system must be at least equal to the current capacity of the associated receptacle.

STANDBY POWER CONNECTIONS

The Vantage® 500 is suitable for temporary, standby or emergency power using the engine manufacturer's recommended maintenance schedule.

The Vantage® 500 can be permanently installed as a standby power unit for 240 volt, three-wire, 50 amp service. Connections must be made by a licensed electrician who can determine how the 120/240 VAC power can be adapted to the particular installation and comply with all applicable electrical codes. The following information can be used as a guide by the electrician for most applications. Refer to the connection diagram shown in **Figure A1.1**.

1. Install the double-pole, double-throw switch between the power company meter and the premises disconnect.

Switch rating must be the same as or greater than the customer's premises disconnect and service over current protection.

2. Take necessary steps to assure load is limited to the capacity of the Vantage by installing a 50 amp, 240 VAC double-pole circuit breaker. Maximum rated load for each leg of the 240 VAC auxiliary is 50 amperes. Loading above the rated output will reduce output voltage below the allow-

able -10% of rated voltage, which may damage appliances or other motor-driven equipment and may result in overheating of the Vantage 500 engine.

3. Install a 50 amp 120/240 VAC plug (NEMA Type 14-50) to the double-pole circuit breaker using four-conductor cable of the proper size and desired length. (The 50 amp, 120/240 VAC plug is available in the optional K802R plug kit.)
4. Plug this cable into the 50 amp 120/240 volt receptacle on the Vantage 500 case front.

Figure A1.1 Connection of the Vantage® 500 to Premises Wiring

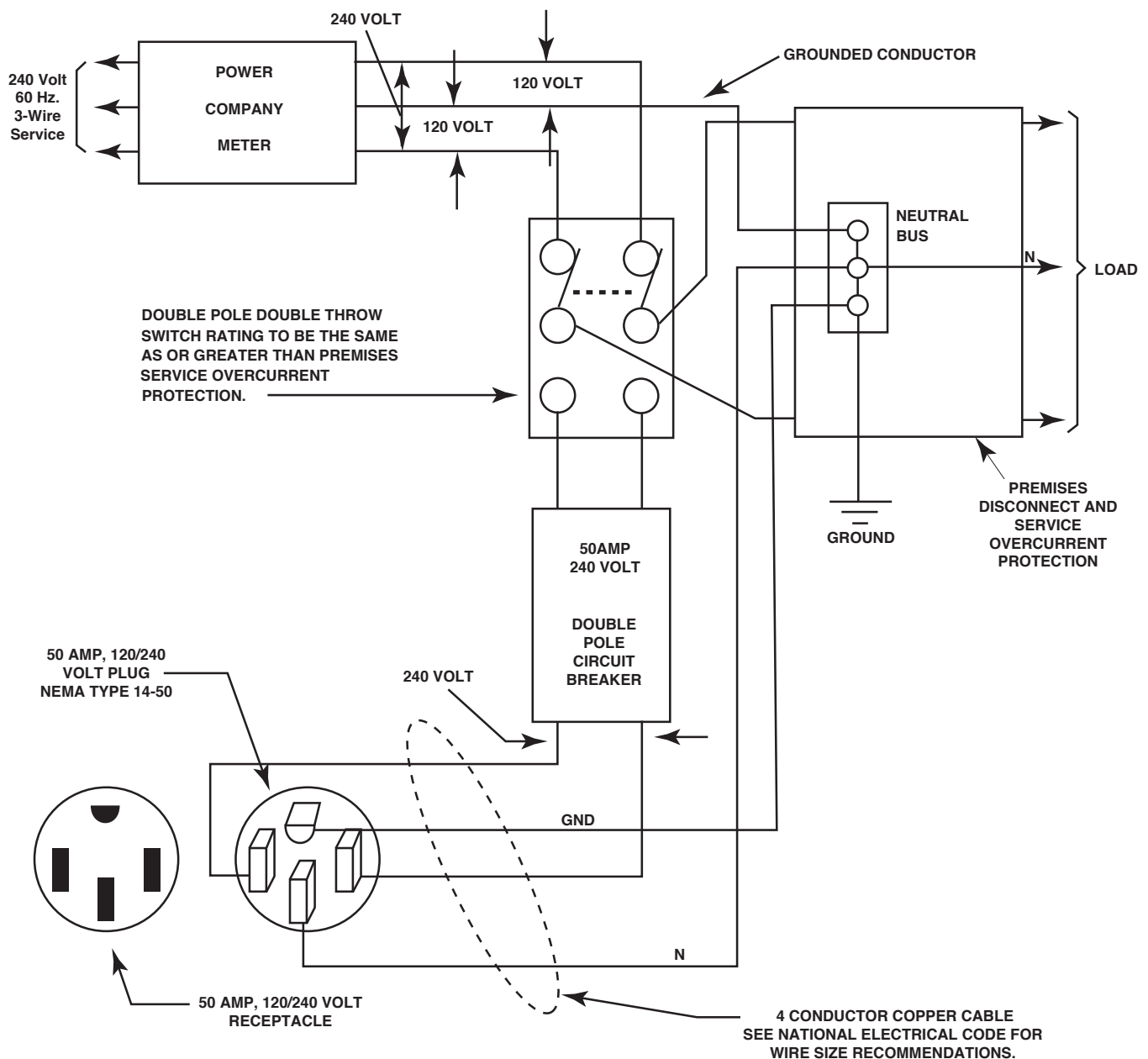

Return to Section TOC

Return to Master TOC

Operation - VANTAGE® 500 Deutz F3L912 (Code 10995)

Operating Instructions B1.2

Safety Instructions B1.2

General Description B1.2

 Recommended Applications B1.3

 Design Features and Advantages B1.3

Controls and Settings B1.4

 Engine Controls B1.4

 Welding Controls B1.5

 Auxiliary Power Controls B1.6

Engine Operation B1.7

 Starting the Engine B1.7

 Stopping the Engine B1.7

 Break-In Period B1.7

 Typical Fuel Consumption B1.7

Welder Operation B1.8

 Stick Welding B1.8

 Constant Current (CC) Welding B1.8

 Pipe Welding B1.8

 TIG Welding B1.8

 Wire Feed (Constant Voltage) Welding B1.10

Auxiliary Power Operation B1.10

 Arc Gouging B1.10

 Paralleling B1.10

Simultaneous Welding and Auxiliary Power Loads B1.11

Extension Cord Recommendations B1.11

Return to Master TOC

Return to Master TOC

Return to Master TOC

Return to Master TOC

OPERATING INSTRUCTIONS

Read and understand this entire section before operating your Vantage® 500.

SAFETY INSTRUCTIONS

WARNING

Do not attempt to use this equipment until you have thoroughly read all operating and maintenance manuals supplied with your machine. They include important safety precautions: detailed engine starting, operating, and maintenance instructions and parts lists.

ELECTRIC SHOCK can kill.



- Do not touch electrically live parts or electrodes with your skin or wet clothing.
- Insulate yourself from the work and ground.
- Always wear dry insulating gloves.

FUMES AND GASES CAN BE DANGEROUS.



- Keep your head out of fumes.
- Use ventilation or exhaust to remove fumes from breathing zone.

WELDING SPARKS CAN CAUSE FIRE OR EXPLOSION.

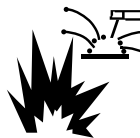

- Keep flammable material away.
- Do not weld on containers that have held combustibles.

ARC RAYS CAN BURN.



- Wear eye, ear, and body protection.



ENGINE EXHAUST can kill.

- Use in open, well ventilated areas or vent exhaust outside
- Do not stack anything near the engine.



MOVING PARTS can injure.

- Do not operate with doors open or guards off.
- Stop engine before servicing.
- Keep away from moving parts

Only qualified personnel should operate this equipment.

ADDITIONAL SAFETY PRECAUTIONS

Always operate the welder with the hinged door closed and the side panels in place, as these provide maximum protection from moving parts and insure proper cooling air flow.

GENERAL DESCRIPTION

The Vantage® 500 is a diesel engine-driven welding power source. The machine uses a brush type alternating current generator for DC multi-purpose welding and for 120/240 VAC auxiliary standby power. The welding control system uses state of the art **Chopper Technology**.

The generator has a single sealed bearing for maintenance free service. The rotor is a copper wound design with two slip rings and brushes. The stator is wound entirely with heavy gauge copper wire and insulated with NEMA class F insulation material. The stator is then impregnated with three layers of high quality varnish. After the stator is assembled using tie bars, the entire assembly is covered with an environmental protective coating. These measures insure trouble-free operation in the harshest environments.

The fuel tank is made from high density polyethylene and holds 25 gallons (94.6 liters) of diesel fuel. This will provide enough fuel to run for more than 12 hours at full load.

The Deutz F3L-912 engine is equipped with a standard, heavy duty, combination fuel filter/water separator element.

VANTAGE® 500



RECOMMENDED APPLICATIONS

WELDER

The Vantage® 500 provides excellent constant current DC welding output for stick (SMAW) and TIG welding. The Vantage® 500 also provides excellent constant voltage DC welding output for MIG (GMAW) and Innershield (FCAW) welding.

GENERATOR

The Vantage® 500 provides smooth 120/240 VAC output for auxiliary power and emergency standby power.

DESIGN FEATURES AND ADVANTAGES

K1639-2 VANTAGE® 500 DELUXE MODEL FEATURES

FOR WELDING

- Excellent DC multi-purpose welding for stick, MIG, TIG, cored wire and arc gouging applications.
- 30 to 500 amps output in five slope-controlled ranges for out-of position and pipe electrodes, one constant current output range for general purpose welding, one constant voltage range for MIG wire and cored wire welding and one 20-250 amp range for "Touch Start" TIG welding.
- 100% duty cycle at 500 amps output and 50% duty cycle at 575 amps output.
- Dual 3-digit output meters are provided (optional on K1639-1) for presetting the weld amperage or voltage and displaying the actual amperage and voltage during welding. The meters use superbrite L.E.D.'s for improved readability in full sunlight.

LOOK-BACK FEATURE: After welding has stopped, both displays will remain on for 7 seconds with the last current and voltage value displayed. During this time, the left-most decimal point in each display will be FLASHING.

- Standard remote control capability with 14-pin and 6-pin connectors for easy connection of Lincoln remote control accessories.
- An internal "Solid State" contactor allows for the selection of "hot" or "cold" output terminals with a toggle switch on the control panel.
- "Arc Control" potentiometer in Wire and Stick modes for precise adjustment of arc characteristics.
- Advanced circuitry to prevent pop-outs in the five slope modes.

FOR AUXILIARY POWER

- 12,000 watts of 120/240 VAC, 60Hz auxiliary power.
- Power for tools, 120/240 VAC lights, electric pumps and for standby emergency power.
- Drive a 5 HP motor (provided it is started under no load).
- Two 20 amp 120 VAC duplex receptacles for up to 40 amps of 120 VAC power.
- One 50 amp, 120/240 VAC dual voltage receptacle for up to 50 amps of 240 VAC, and up to 50 amps per side to separate branch circuits (not in parallel) of 120 VAC single-phase auxiliary power. Allows easy connection to premises wiring.
- Weld and AC auxiliary power at the same time (within machine total capacity).

OTHER FEATURES

- Deutz 3-cylinder, air/oil cooled diesel engine. Designed for long life, easy maintenance, and excellent fuel economy.
- Engine protection system shuts the engine down for low oil pressure, high oil temperature, or a broken fan/engine alternator belt.
- Gauges for oil pressure, oil temperature, engine alternator output, and fuel level.
- Indicator lights for Engine Protection, and Battery (engine alternator low output/broken belt).
- Engine hour meter standard on all models.
- Extended range 25 gallon (94.6 l) fuel tank.
- Automatic idler reduces engine speed when not welding or drawing auxiliary power. This feature reduces fuel consumption and extends engine life.
- Compact size fits crosswise in full size pickup truck.
- Single-side engine service.
- Copper alternator windings and high temperature insulation for dependability and long life.
- New paint system on case and base for outstanding corrosion protection.

VANTAGE® 500



CONTROLS AND SETTINGS

All welder and engine controls are located on the case front panel. Refer to Figure B.1 and the explanations that follow.

Figure B.1.1 Case Front Panel Controls

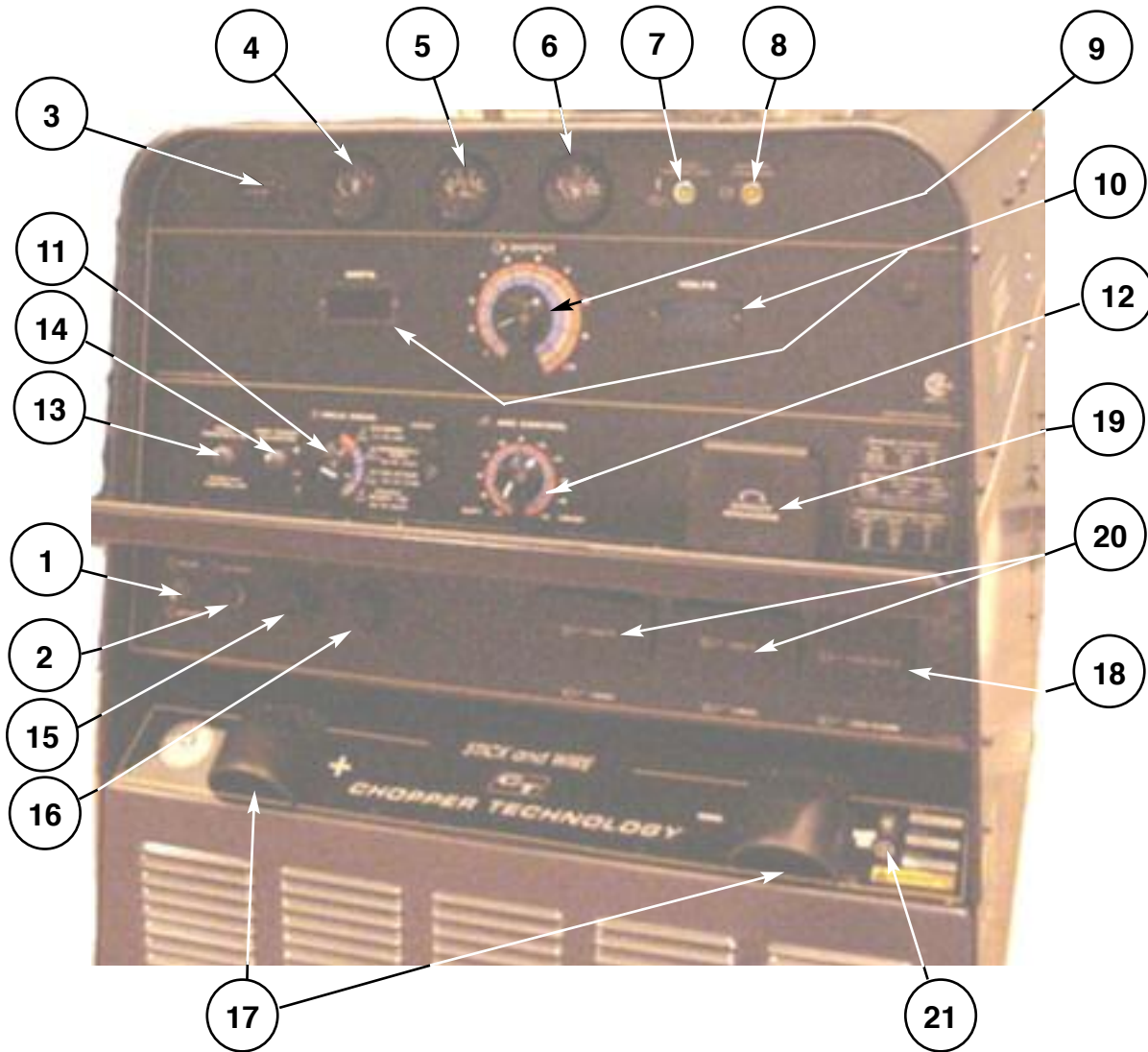

ENGINE CONTROLS (Items 1 through 9)

1. RUN STOP SWITCH

Toggling the switch to the RUN position energizes the fuel solenoid for approximately 30 seconds. The engine must be started within that time or the fuel solenoid will deenergize, and the switch must be toggled to reset the timer.

2. START PUSHBUTTON

Energizes the starter motor to crank the engine. With the engine "Run / Stop" switch in the "Run" position, push and hold the Start button to crank the engine; release as the engine starts. Do not press while engine is running since this can cause damage to the ring gear and/or starter motor

3. HOUR METER

The hour meter displays the total time that the engine has been running. This meter is a useful indicator for scheduling preventive maintenance.

4. FUEL LEVEL GAUGE

Displays the level of diesel fuel in the fuel tank.

The operator must watch the fuel level closely to prevent running out of fuel and possibly having to bleed the system.

5. ENGINE TEMPERATURE GAUGE

The gauge displays the engine coolant temperature.

VANTAGE® 500

LINCOLN
ELECTRIC

6. OIL PRESSURE GAUGE 

The gauge displays the engine oil pressure when the engine is running.

7. ENGINE PROTECTION

The yellow engine protection light remains off with proper oil pressure and under normal operating temperatures. If the light turns on, the engine protection system will stop the engine. Check for proper oil and coolant levels and add oil and/or coolant if necessary. Check for loose or disconnected leads at the oil pressure sender located on the engine. The light will remain on when the engine has been shut down as long as the Run/Stop switch is in the Run position.

NOTE: This engine is equipped with an electronic governor system. The engine speed ramps up during a warm up period. The complete cycle takes approximately 3 minutes. This allows the engine cylinder temperature to build up slowly before going to full speed. This feature is bypassed if the engine is already warm. The Engine may produce "White Smoke" for a few minutes at low temperatures. Do not apply a load to the machine during the warm up period.

8. BATTERY CHARGING LIGHT 

The yellow engine alternator light is off when battery charging system is functioning normally. If light turns on the alternator or the voltage regulator may not be operating correctly. The light will remain on when the engine is stopped and the Run/Stop switch is in the Run position.

WELDING CONTROLS (Items 9 through 17)

9. OUTPUT CONTROL: The OUTPUT dial is used to preset the output voltage or current as displayed on the digital meters for the four welding modes. When in the CC-STICK, DOWNHILL PIPE or CV-WIRE modes and when a remote control is connected to the 6-Pin or 14-Pin Connector, the auto-sensing circuit automatically switches the OUTPUT CONTROL from control at the welder to the remote control. In the CV-WIRE mode, when the wire feeder control cable is connected to the 14-pin connector the auto-sensing circuit automatically makes OUTPUT CONTROL inactive and the wire feeder voltage control (if present) active.

When in the TOUCH START TIG mode and when a Amptrol is connected to the 6-pin Connector, the OUTPUT dial is used to set the maximum current range of the CURRENT CONTROL of the Amptrol.

10. DIGITAL OUTPUT METERS: (Optional)

The digital meters allow the output voltage (CV-WIRE mode) or current (CC-STICK, DOWNHILL PIPE and TIG modes) to be set prior to welding using the OUTPUT control knob. During welding, the meters display the actual output voltage (VOLTS) and current (AMPS). A memory feature holds the display of both meters on the seven seconds after welding is stopped. This allows the operator to read the actual current and voltage just prior to when welding was ceased. While the display is being held the left-most decimal point in each display will be flashing. The accuracy of the meters is $\pm 3\%$.

11. WELD MODE SELECTOR SWITCH:

(Provides four selectable welding modes)

- CV-WIRE
- DOWNHILL PIPE
- CC-STICK
- TOUCH START TIG

12. ARC CONTROL:

The ARC CONTROL WIRE/STICK knob is active in the WIRE and STICK modes, and has different functions in these modes. This control is not active in the TIG mode.

CC-STICK mode: In this mode, the ARC CONTROL knob sets the short circuit current (arc-force) during stick welding. Increasing the number from -10(Soft) to +10 (Crisp) increases the short circuit current and prevents sticking of the electrode to the plate while welding. This can also increase spatter. It is recommended that the ARC CONTROL be set to the minimum number without electrode sticking. Start with a setting at 0.

DOWNHILL PIPE mode: In this mode, the ARC CONTROL knob sets the short circuit current (arc-force) during stick welding to adjust for a soft or a more forceful digging arc (Crisp). Increasing the number from -10 (Soft) to +10 (Crisp) increases the short circuit current which results in a more forceful digging arc. Typically a forceful digging arc is preferred for root and hot passes. A softer arc is preferred for fill and cap passes where weld puddle control and deposition ("stacking" of iron) are key to fast travel speeds. It is recommended that the ARC CONTROL be set initially at 0.

CV-WIRE mode: In this mode, turning the ARC CONTROL knob from -10(soft) to +10(crisp) changes the arc from soft and washed-in to crisp and narrow. It acts as an inductance/pinch control. The proper setting depends on the procedure and operator preference. Start with a setting of 0.

13. WELDING TERMINALS SWITCH

In the WELD TERMINALS ON position, the output is electrically hot all the time. In the REMOTELY CONTROLLED position, the output is controlled by a wire feeder or amptrol device, and is electrically off until a remote switch is depressed.

14. WIRE FEEDER VOLTMETER SWITCH:

Matches the polarity of the wire feeder voltmeter to the polarity of the electrode.

15. 6 - PIN CONNECTOR

For attaching optional remote control equipment. Includes auto-sensing remote control circuit.

16. 14 - PIN CONNECTOR

For attaching wire feeder control cables. Includes contactor closure circuit, auto-sensing remote control circuit, and 120VAC and 42VAC power.

NOTE: When a wire feeder with a built in welding voltage control is connected to the 14-pin connector, do not connect anything to the 6-pin connector.

7. WELD OUTPUT TERMINALS + AND –

These 1/2" - 13 studs with flange nuts provide welding connection points for the electrode and work cables. For positive polarity welding the electrode cable connects to the "+" terminal and the work cable connects to this "-" terminal. For negative polarity welding the work cable connects to the "+" terminal and the electrode cable connects to this "-" terminal.

AUXILIARY POWER CONTROLS (Items 18-21)**18. 120/240 VAC SINGLE PHASE RECEPTACLE**

This is a 120/240VAC (14-50R) receptacle that provides 240VAC or can be split for 120VAC single phase auxiliary power. This receptacle has a 50 amp rating. Refer to the AUXILIARY POWER RECEPTACLES section in the installation chapter for further information about this receptacle. Also refer to the AUXILIARY POWER OPERATION section later in this chapter.

20. CIRCUIT BREAKERS

These circuit breakers provide separate overload current protection for each 120V circuit at the 240V single phase receptacle, each 120V single phase receptacle, the 240V three phase receptacle, the 120VAC in the 14-Pin connector, the 42VAC in the 14-Pin connector and battery circuit overload protection.

21. 120VAC SINGLE PHASE RECEPTACLES

These two 120VAC (5-20R) receptacles with GFCI protection provide 120VAC single phase for auxiliary power. Each receptacle has a 20 amp total rating. They are designed to protect the user from the hazards of ground faults. When the GFCI has tripped there will be no voltage available from the receptacle. Refer to the AUXILIARY POWER RECEPTACLES section in the installation chapter for further information about these receptacles. Also refer to the AUXILIARY POWER OPERATION section later in this chapter.

22. GROUND STUD

Provides a connection point for connecting the machine case to earth ground. Refer to "**MACHINE GROUNDING**" in the Installation chapter for proper machine grounding information.

ENGINE OPERATION

STARTING THE ENGINE

1. Open the engine compartment door and check that the fuel shutoff valve is in the open position (lever to be in line with the hose).
2. Check for proper oil level and coolant level. Close engine compartment door.
3. Remove all plugs connected to the AC power receptacles.
4. Set IDLER switch to "AUTO".
5. Set the RUN/STOP switch to "RUN". Observe that the engine protection and battery charging lights are on. The engine protection light may turn off after 5 seconds or remain on until the engine is started.
6. Within 30 seconds, press and hold the engine START button until the engine starts. If the engine does not start within 30 seconds the RUN/STOP switch must be returned to the STOP position, then return to step 5.
7. Release the engine START button when the engine starts.
8. Check that the engine protection and battery charging lights are off. Investigate any indicated problem.

NOTE: The engine will go through a 3 minute warm-up cycle if cold. If the engine coolant is still warm from recent operation, the engine will go immediately to high idle and then to low idle if the idle switch is in the "AUTO" position.

COLD WEATHER STARTING

With a fully charged battery and the proper weight oil, the engine should start satisfactorily even down to about 0°F(-18°C). If the engine must be frequently started below 10°(-12°C), it may be desirable to install the optional ether start kit (K887-1). Installation and operating instructions are included in the kits.

STOPPING THE ENGINE

Switch the RUN/STOP switch to "STOP". This turns off the voltage supplied to the shutdown solenoid. A back-up shutdown can be accomplished by shutting off the fuel valve located on the fuel line.

BREAK-IN PERIOD

The engine used to supply power for your welder is a heavy duty, industrial engine. It is designed and built for rugged use. It is very normal for any engine to use small quantities of oil until the break-in is accomplished. Check the oil level twice a day during the break-in period. In general this takes 50 to 100 hours of operation.

IMPORTANT

IN ORDER TO ACCOMPLISH THIS BREAK-IN, THE UNIT SHOULD BE SUBJECTED TO HEAVY LOADS, WITHIN THE RATING OF THE MACHINE. AVOID LONG IDLE RUNNING PERIODS.

TYPICAL FUEL CONSUMPTION

Refer to **Table B1.1** for typical fuel consumption of the VANTAGE 500 Engine for various operating scenarios.

**Table B1.1 – DEUTZ F3L 912
ENGINE FUEL CONSUMPTION**

	Deutz F3L 912 44.2 HP @1800 rpm	Running Time for 25 Gallons (Hours)
High Idle No Load 1900 rpm	.66 gallons/hour (2.50 liters/hour)	37.9
DC-CC Welding 500A @40V	1.94 gallons/hour (7.34 liters/hour)	12.9
Auxiliary Power 12,000 VA	1.31 gallons/hour (4.96 liters/hour)	19.1

WELDER OPERATION

DUTY CYCLE

Duty Cycle is the the ratio of the uninterrupted on-load duration to 10 minutes. The total time period of one complete on-load and no-load cycle is 10 minutes. For example, in the case of a 60% duty cycle, load is applied continuously for 6 minutes followed by a no-load period of 4 minutes.

STICK WELDING MODE

The Vantage can be used with a broad range of DC stick electrodes.

The MODE switch provides two stick welding settings as follows:

CC-STICK MODE

The CC-STICK position of the MODE switch is designed for horizontal, vertical-up and overhead welding with all types of electrodes, especially low hydrogen. The OUTPUT CONTROL knob adjusts the full output range for stick welding.

The ARC CONTROL knob sets the short circuit (arc-force) current during stick welding. Increasing the number from -10 (Soft) to +10 (Crisp) increases the short circuit current and prevents sticking of the electrode to the plate while welding. This can also increase spatter. It is recommended that the ARC CONTROL be set to the minimum number without electrode sticking. Start with the knob set at 0.

DOWNHILL PIPE MODE

This slope controlled setting is intended for “out-of-position” and “down hill” pipe welding where the operator would like to control the current level by changing the arc length. The OUTPUT CONTROL knob adjusts the full output range for pipe welding.

The ARC CONTROL knob sets the short circuit current (arc-force) during stick welding to adjust for a soft or a more forceful digging arc (Crisp). Increasing the number from -10 (Soft) to +10 (Crisp) increases the short circuit current which results in a more forceful digging arc. Typically a forceful digging arc is preferred for root and hot passes. A softer arc is preferred for fill and cap passes where weld puddle control and deposition (“stacking” of iron) are key to fast travel speeds. It is recommended that the ARC CONTROL be set initially at 0.

TOUCH START TIG MODE

The Vantage® 500 can be used in a wide variety of DC TIG welding applications.

The TOUCH START TIG setting of the MODE switch is for DC TIG (Tungsten Inert Gas) welding. To initiate a weld, the OUTPUT CONTROL knob is first set to the desired current and the tungsten is touched to the work. During the time the tungsten is touching the work there is very little voltage or current and, in general, avoids tungsten contamination. Then, the tungsten is gently lifted off the work in a rocking motion, which establishes the arc.

To stop the arc, simply lift the TIG torch away from the work piece. When the arc voltage reaches approximately 30 volts, the arc will go out and the machine will automatically reset to the touch start current level. The tungsten may then be retouched to the work piece to restrike the arc. The arc may also be started and stopped with an Amptrol or Arc Start Switch.

The ARC CONTROL is not active in the TIG mode.

In general the ‘Touch Start’ feature avoids tungsten contamination without the use of a Hi-frequency unit. If the use of a high frequency generator is desired, the K930-2 TIG Module can be used with the Vantage. The settings are for reference.

The Vantage is equipped with the required R.F. bypass circuitry for the connection of high frequency generating equipment.

The Vantage and any high frequency generating equipment must be properly grounded. See the K930-2 TIG Module operating manuals for complete instructions on installation, operation, and maintenance.

When using the TIG Module, the OUTPUT control on the Vantage is used to set the maximum range of the CURRENT CONTROL on the TIG Module or an Amptrol if connected to the TIG Module.

TABLE B1.2 – TYPICAL CURRENT RANGES¹ FOR TUNGSTEN ELECTRODES²

Tungsten Electrode Diameter in. (mm)	DCEN (-)	DCEP (+)	Approximate Argon Gas Flow Rate C.F.H. (l/min.)		TIG TORCH Nozzle Size ^{4,5}
	1%, 2% Thoriated Tungsten	1%, 2% Thoriated Tungsten	Aluminum	Stainless Steel	
0.010 (.25)	2-15	³	3-8 (2-4)	3-8 (2-4)	#4, #5, #6
0.020 (.50)	5-20	³	5-10 (3-5)	5-10 (3-5)	
0.40 (1.0)	15-80	³	5-10 (3-5)	5-10 (3-5)	
1/16 (1.6)	70-150	10-20	5-10 (3-5)	9-13 (4-6)	#5, #6
3/32 (2.4)	150-250	15-30	13-17 (6-8)	11-15 (5-7)	#6, #7, #8
1/8 (3.2)	250-400	25-40	15-23 (7-11)	11-15 (5-7)	
5/32 (4.0)	400-500	40-55	21-25 (10-12)	13-17 (6-8)	#8, #10
3/16 (4.8)	500-750	55-80	23-27 (11-13)	18-22 (8-10)	
1/4 (6.4)	750-1000	80-125	28-32 (13-15)	23-27 (11-13)	

¹When used with argon gas. The current ranges shown must be reduced when using argon/helium or pure helium shielding gases.

²Tungsten electrodes are classified as follows by the American Welding Society (AWS):

Pure	EWP
1% Thoriated	EWTh-1
2% Thoriated	EWTh-2

Though not yet recognized by the AWS, Ceriated Tungsten is now widely accepted as a substitute for 2% Thoriated Tungsten in AC and DC applications.

³DCEP is not commonly used in these sizes.

⁴TIG torch nozzle "sizes" are in multiples of 1/16ths of an inch:

# 4 = 1/4 in. (6 mm)	# 7 = 7/16 in. (11 mm)
# 5 = 5/16 in. (8 mm)	# 8 = 1/2 in. (12.5 mm)
# 6 = 3/8 in. (10 mm)	#10 = 5/8 in. (16 mm)

⁵TIG torch nozzles are typically made from alumina ceramic. Special applications may require lava nozzles, which are less prone to breakage, but cannot withstand high temperatures and high duty cycles.

VANTAGE 500 SETTINGS WHEN USING THE K799 HI-FREQ UNIT

- Set the WELD MODE switch to the 20-250 setting (TIG).
- Set the IDLER switch to the HIGH position.
- Set the WELDING TERMINALS switch to the WELD TERMINALS ON position. This will close the solid state contactor and provide an always "hot" electrode.

NOTE: This is necessary because the K799 circuitry does not provide the proper signal to open and close the solid state contactor in the Vantage 500.

VANTAGE 500 SETTINGS WHEN USING A K930-[] TIG MODULE

- Set the WELD MODE switch to the 20-250 setting (TIG).
- Set the IDLER switch to the AUTO position.
- Set the WELDING TERMINALS switch to the REMOTELY CONTROLLED position. This will keep the solid state contactor open and provide a "cold" electrode until the triggering device (Amptrol or Arc Start Switch) is pressed.

VANTAGE® 500



WIRE FEED (CONSTANT VOLTAGE) WELDING

Connect a wire feeder to the Vantage® 500 and set welder controls according to the instructions listed earlier in this section. See the operator's manual for the wire feeder or the "Diagrams" section of this manual for connecting instructions of various Lincoln wire feeders.

The Vantage® 500 in the CV-WIRE position can be used with a broad range of flux cored wire (Innershield and Outershield) electrodes and solid wires for MIG welding (GMAW). Welding can be finely tuned using the ARC CONTROL.

Some recommended Innershield electrodes are: NR-311, NS-3M, NR-207, NR-203 Ni 1%, NR-204-H.

Recommended Outershield electrodes are: 0S-70, 0S-71M.

Some recommended solid wires for MIG welding are: .035 (0.9 mm), .045 (1.1 mm) and .052 (1.3 mm), L-50 and L-56, .035 (0.9 mm) and .045 (1.1 mm) Blue Max MIG 308 LS.

For any electrodes, including the above recommendations, the procedures should be kept within the rating of the machine. For additional electrode information, see Lincoln publications N-675, GS-100 and GS-210.

AUXILIARY POWER OPERATION

Full power is available regardless of the welding control settings, if no welding current is being drawn.

The auxiliary power of the Vantage® 500 consists of two 20 Amp-120VAC (5-20R) duplex receptacles and one 50 Amp-120/240 VAC (14-50R) receptacle. The 120/240VAC receptacle can be split for single phase 120 VAC operation.

The auxiliary power capacity is 12,000 watts of 60 Hz, single phase power. The auxiliary power capacity rating in watts is equivalent to volt-amperes at unity power factor. The maximum permissible current of the 240 VAC output is 50 A. The 240 VAC output can be split to provide two separate 120 VAC outputs with a maximum permissible current of 50 A per output to two separate 120 VAC branch circuits. Output voltage is within $\pm 10\%$ at all loads up to rated capacity.

NOTE: The 120/240V receptacle has two 120V outputs of different phases and cannot be paralleled.

The auxiliary power receptacles should only be used with three-wire grounded type plugs or approved double insulated tools with two wire plugs.

The current rating of any plug used with the system must be at least equal to the current capacity of the associated receptacle.

SIMULTANEOUS WELDING AND AUXILIARY POWER LOADS

It must be noted that the above auxiliary power ratings are with no welding load. Simultaneous welding and power loads are specified in **Table B1.3**. The permissible currents shown assume that current is being drawn from either the 120 VAC or 240 VAC supply (not both at the same time).

ARC GOUGING

For optimal performance when arc gouging, set the Vantage® 500 WELD MODE switch to the CC - STICK position, and the ARC CONTROL to 10.

Set the OUTPUT knob to adjust output current to the desired level for the gouging electrode being used according to the ratings in the following table:

Electrode Diameter	Current Range (DC, electrode positive)
1/8"	30-60 Amps
5/32"	90-150 Amps
3/16"	150-200 Amps
1/4"	200-400 Amps
5/16"	250-400 Amps
3/8"	350-575 Amps*

* Maximum current setting is limited to the Vantage 500 maximum of 575 Amps.

PARALLELING

When paralleling machines in order to combine their outputs, all units must be operated in the CC - STICK mode only. To achieve this, turn the WELD MODE switch to the CC - STICK position. Operation in other modes may produce erratic outputs and large output imbalances between the units.

TABLE B1.3 Vantage 500 Duetz Simultaneous Welding and Power Loads

Welding Output at NEMA Voltage ($V = .04I + 20$)	Permissible Power Watts (Unity Power Factor)	Permissible Auxiliary Current in Amperes	
		@ 120VAC * +/- 10%	@ 240 VAC +/- 10%
0-250A/30V	12,000	100**	50
350A/34V	8,100	68**	34
400A/36V	5,600	46	23
450A/38V	2,900	24	12
500A/40V	0	0	0

* Each duplex receptacle is limited to 20 amps.

** Not to exceed 50A per 120 VAC branch circuit when splitting the 240 VAC output.

EXTENSION CORD RECOMMENDATIONS

An extension cord can be used with the auxiliary power outputs as long as it is of ample size. Table B1.4 lists permissible extension cord lengths based on conductor size and auxiliary power output.

TABLE B1.4 – VANTAGE 500 EXTENSION CORD LENGTH RECOMMENDATIONS

Current (Amps)	Voltage (Volts)	Load (Watts)	Maximum Allowable Cord Length in ft. (m) for Conductor Size											
			14 AWG		12 AWG		10 AWG		8 AWG		6 AWG		4 AWG	
15	120	1800	30	(9)	40	(12)	75	(23)	125	(38)	175	(53)	300	(91)
15	240	3600	60	(18)	75	(23)	150	(46)	225	(69)	350	(107)	600	(183)
20	120	2400			30	(9)	50	(15)	88	(27)	138	(42)	225	(69)
20	240	48010			60	(18)	100	(30)	175	(53)	275	(84)	450	(137)
25	240	6000					90	(27)	150	(46)	225	(69)	250	(76)
30	240	7200					75	(23)	120	(37)	175	(53)	300	(91)
38	240	9000							100	(30)	150	(46)	250	(76)
50	240	12000									125	(38)	200	(61)

Conductor size is based on maximum 2.0% voltage drop.

Return to Section TOC

Return to Section TOC

Return to Section TOC

Return to Section TOC

Return to Master TOC

Return to Master TOC

Return to Master TOC

Return to Master TOC

VANTAGE® 500



Accessories - VANTAGE® 500 Deutz F3L912 (Code 10995)

Options/AccessoriesC1.1

 Optional Field Installed AccessoriesC1.2

 Plasma Cutting OptionC1.2

 TIG Welding OptionsC1.3

 High Frequency Generators for TIG ApplicationsC1.3

 Wire Feeder OptionsC1.3

Return to Master TOC

Return to Master TOC

Return to Master TOC

Return to Master TOC

OPTIONAL FIELD INSTALLED ACCESSORIES

K802N POWER PLUG KIT - Provides four 120V plugs rated at 20 amps each and one dual voltage, full KVA plug rated at 120/240V, 50 amps. The 20 amp/120V plug may not be compatible with NEMA common household receptacles.

K802R POWER PLUG KIT - Provides four 120V plugs rated 15 amps each and one dual voltage, full KVA plug rated at 120/240V, 50 amps. The 15 amp/120V plug is compatible with NEMA common household receptacles.

K857 25 ft. (7.5 m) or K857-1 100 ft. (30.4 m) REMOTE CONTROL - Portable control provides same dial range as the output control on the welder from a location up to the specified length from the welder. Has convenient plug for easy connection to the welder. The VANTAGE® 500 is equipped with a 6-pin connector for connecting the remote control.

K704 ACCESSORY SET - Includes 35 feet (10 m) of electrode cable and 30 feet (9 m) of work cable, head-shield, Filter plate, work clamp and electrode holder. Cable is rated at 500 amps, 60% duty cycle.

K2641-2 FOUR WHEELED STEERABLE YARD TRAILER

For in plant and yard towing. Comes standard with a Duo-Hitch™, a 2" Ball and Lunette Eye combination hitch.

K2636-1 TRAILER - Two-wheeled trailer with optional fender and light package. For highway use, consult applicable federal, state, and local laws regarding possible additional requirements. Comes standard with a Duo-Hitch™, a 2" Ball and Lunette Eye combination hitch, a fender & a light package. **Order:**

K2636-1 Trailer

K958-1 Ball Hitch

K958-2 Lunette Eye Hitch

K2639-1 Fender & Light Kit

K2640-1 Cable Rack

K887-1 ETHER START KIT - Provides maximum cold weather starting assistance for frequent starting below 10°(-12°C). Required Ether tank is not provided with kit.

K899-1 SPARK ARRESTOR KIT - Easily mounts to standard muffler.

K949-1 Oil Drain Kit - includes ball valve, hose and clamp.

K1816-1 Full KVA Adapter Kit - Plugs into the 120/240V NEMA 14-50R receptacle on the case front (which accepts 4-prong plugs) and converts it to a NEMA 6-50R receptacle (which accepts 3-prong plugs) for connection to Lincoln Equipment with a NEMA 6-50P plug,

T12153-9 Full-KVA Power Plug-One dual voltage plug rated at 120/240V, 50 amps, single phase.

K2356-1 Control Panel Cover Kit-Clear plexiglass cover to protect control panel from dirt and debris, and to visually monitor machine operation. Lockable to deter vandalism.

K2340-1 Lockable Fuel Cap / Flash Arrester Kit-For use in locations where flash arrester safety is required. Lockable fuel cap prevents tampering with fuel. Green cap color provides a visual reminder to use diesel when refueling.

PLASMA CUTTING

K1581-1 Pro-cut 80 - Cuts mild steel using the 3-phase AC generator power from the engine driven welder.

NOTE: Other Linclon plasma cutters, both single phase and 3 phase can be used as long as the rating of the receptacle is not exceeded

WARNING

Pipe Thawing with an arc welder can cause fire, explosion, damage to electric wiring or to the arc welder if done improperly. The use of an arc welder for pipe thawing is not approved by the CSA, nor is it recommended or supported by Lincoln Electric.

VANTAGE® 500



TIG OPTIONS

K1783-9 PTA-26V TIG Torch

Air Cooled 200 amp torch (2 piece) equipped with valve for gas flow control. 25 ft. (7.6m) length.

KP509 Magnum Parts Kit for PTA-26V TIG Torch

Magnum Parts Kit provides all the torch accessories you need to start welding. Parts kit provides collets, collet bodies, a black cap, alumina nozzles and tungstens in a variety of sizes, all packaged in an easy to carry reclosable sack.

K870 Foot Amptrol®-Varies current while welding for making critical TIG welds and crater filling. Depress pedal to increase current. Depressing pedal fully achieves maximum set current. Fully raising the pedal finishes the weld and starts the after flow cycle on systems so equipped. Includes 25 ft. (7.6m) control cable.

K963-3 Hand Amptrol®-Varies current for making critical TIG welds. Fastens to the torch for convenient thumb control. Comes with a 25 ft. (7.6m) cable. (One size fits all Pro-Torch TIG Torches.)

K2347-1 Precision TIG 185 Ready-Pak

For AC TIG Welding with square wave performance use the AC generator of the Engine-Driven Welder to supply the power. Easy setup. Includes torch, foot amptrol, gas regulator and hose. Requires the K1816-1 Full KVA adapter kit.

K2350-1 Invertec® V205-T AC/DC One-Pak™ Package

For AC TIG welding with square wave performance, use the AC generator of the engine-driven welder to supply the power. Easy setup. Includes torch, parts kit, regulator and hose kit, Twist-Mate™ torch adapter, work cable with Twist-Mate end and foot Amptrol®.

HIGH FREQUENCY GENERATORS FOR TIG APPLICATIONS

The K799 Hi-Freq Unit (obsolete) and the K930- [] TIG Modules are suitable for use with the Vantage 500. The Vantage® 500 is equipped with the required RF bypass circuitry for the connection of high frequency generating equipment. The high frequency bypass network supplied with the K799 Hi-Freq Unit does NOT need to be installed into the Vantage® 500.

The Vantage® 500 and any high frequency-generating equipment must be properly grounded. See the K799 Hi-Freq Unit and the K930-All TIG Module operating manuals for complete instructions on installation, operation, and maintenance.

WIRE FEEDER OPTIONS

K449 LN-25 Wire Feeder

Portable CC/CV unit for flux-cored and MIG welding. Includes Gas Solenoid & Internal Contactor.

K126-2 Magnum® 350 Innershield Gun (for LN-25)

For self-shielded wire with 15 ft. (4.5m) cable. For .062-3/32" (1.6-2.4mm) wire.

KP653-3/32 Drive Roll and Guide Tube Kit (for LN-25)
For .068-3/32" (1.8-2.4mm) cored or solid steel wire.

K1802-1 Magnum® 300 MIG Gun

For .035-.045 (0.9-1.2mm) gas shielded wire. Includes 15 ft. gun and cable assembly and connector kit.

KP653-035S Drive Roll and Guide Tube Kit (for LN-25)

For .035-.040" (0.9-1.0mm) solid steel wire.

K2613-1 LN-25 PRO PORTABLE WIRE FEEDER-The MAXTRAC® wire drive enhances performance, while the replacement case, and many other upgrade options that can be installed in less than five minutes aid in the serviceability.

KP1697-5/64 Drive Roll Kit- Includes: 2 polished U groove drive rolls, outer wire guide and inner wire guide for solid core wire. (Used on LN-25 Pro)

KP1697-068 Drive Roll Kit- Includes: 2 polished U groove drive rolls, outer wire guide and inner wire guide for solid core wire. (Used on LN-25 Pro)

KP1696-1 Drive Roll Kit- Includes: 2 V groove drive rolls and inner wire guide for Steel Wires. (Used on LN-25 Pro)

K487-25 Magnum SG Spool Gun

Hand held semiautomatic wire feeder. Requires SG Control Module and Input Cable.

K488 SG Control Module

The Interface between the power source and the spool gun. Provides control of the wire speed and gas flow. For use with a spool gun.

K691-10 Input Cable (For SG Control Module)

For Lincoln engine power sources with 14-pin MS-type connection, separate 115V NEMA receptacles and output stud connections.

OTHER WIRE FEEDERS USABLE WITH THE VANTAGE 500

- NA-3 or LT-7 Automatic Wire Feeder
- LN-742 Semi-automatic Wire Feeder
- LF-72/74 Semi-automatic Wire feeder
- LN-7 Semi-automatic Wire Feeder
- LN-8 Semi-automatic Wire Feeder
- LN-23P Semi-automatic Wire Feeder
- LN-15 Semi-automatic Wire Feeder

See the Wire Feeder Manual or the Diagrams section of this manual for connection information of the various feeders to the Vantage 500.

VANTAGE® 500



Return to Section TOC
Return to Section TOC
Return to Section TOC
Return to Section TOC
Return to Master TOC
Return to Master TOC
Return to Master TOC
Return to Master TOC

VANTAGE® 500



Maintenance - VANTAGE® 500 Deutz F3L912 (Code 10995)

Safety Precautions	D1.2
Routine and Periodic Maintenance	D1.2
Engine Maintenance	D1.2
Change the Oil and Oil Filter	D1.2
Fuel	D1.3
Fuel Filters	D1.4
Bleeding the Fuel System	D1.6
Air Filter	D1.6
Cooling System	D1.8
Cooling Blower Belt	D1.8
Engine Maintenance Schedules and Parts	D1.9
Battery Maintenance	D1.10
Cleaning the Battery	D1.10
Checking Specific Gravity	D1.10
Checking Electrolyte Level	D1.10
Charging the Battery	D1.10
Welder/Generator Maintenance	D1.11
Storage	D1.11
Cleaning	D1.11
Nameplates	D1.11
Brush Removal and Replacement	D1.11
Bearings	D1.11
Receptacles	D1.11
Cable Connections	D1.11
Major Component Locations	D1.12

SAFETY PRECAUTIONS

WARNING

- Have qualified personnel do all maintenance and troubleshooting work.
- Turn the engine off before working inside the machine.
- Remove covers or guards only when necessary to perform maintenance and replace them when the maintenance requiring their removal is complete.
- If covers or guards are missing from the machine, get replacements from a Lincoln Distributor.

Read the Safety Precautions in the front of this manual and in the instruction manual for the diesel engine used with your machine before working on the Vantage® 500.

Keep all equipment safety guards, covers, and devices in position and in good repair. Keep your hands, hair, clothing, and tools away from the fans, and all other moving parts when starting, operating, or repairing this machine.

ROUTINE AND PERIODIC MAINTENANCE

ENGINE MAINTENANCE

DAILY

- Check the crankcase oil level.
- Refill the fuel tank to minimize moisture condensation in the tank.
- Open the water drain valve located on the bottom of the water separator element one or two turns and allow to drain into a container suitable for diesel fuel for two to three seconds. Repeat the above drainage procedure until diesel fuel is detected in the container.

WEEKLY

Blow out the machine with low pressure air periodically. In particularly dirty locations, this may be required once a week.



CAUTION

To prevent the engine from accidentally starting, disconnect the negative battery cable before servicing the engine.

See *Table D1.1* for a summary of maintenance intervals for the items listed below. Follow either the hourly or the calendar intervals, whichever come first. More frequent service may be required, depending on your specific application and operating conditions.

OIL: Check the oil level after every 8 hours of operation or daily. BE SURE TO MAINTAIN THE OIL LEVEL.

Change the oil the first time between 25 and 50 hours of operation. Then, under normal operating conditions, change the oil as specified in *Table D1.1*. If the engine is operated under heavy load or in high ambient temperatures, change the oil more frequently.

CHANGE THE OIL AND FILTER

CHANGE THE OIL: Change the oil, while the engine is still warm, as follows:

- Drain the oil from the drain plug located on the engine bottom, as shown in *Figure D1.1*. Examine the washer and replace it if it appears damaged.
- Replace the plug and washer and tighten firmly.
- Remove the oil fill cap and add 9 quarts (8.5 L) of oil. Check the dipstick and slowly add oil until the level reaches the "MAX" mark on the dipstick. See *Figure D1.1*. Use high quality oil viscosity grade 10W40. Consult the engine manual for oil specifications for various ambient temperatures. Always check the level with the dipstick before adding more oil.
- Reinstall the oil fill cap and the dipstick.
- If the oil filter has been changed, run the engine and re-check the level. Add oil as necessary until the level reaches the "MAX" mark.

NOTE: The K949-1 Oil Drain Kit can be installed to facilitate future oil changes.

FIGURE D1.1 – OIL DRAIN AND REFILL

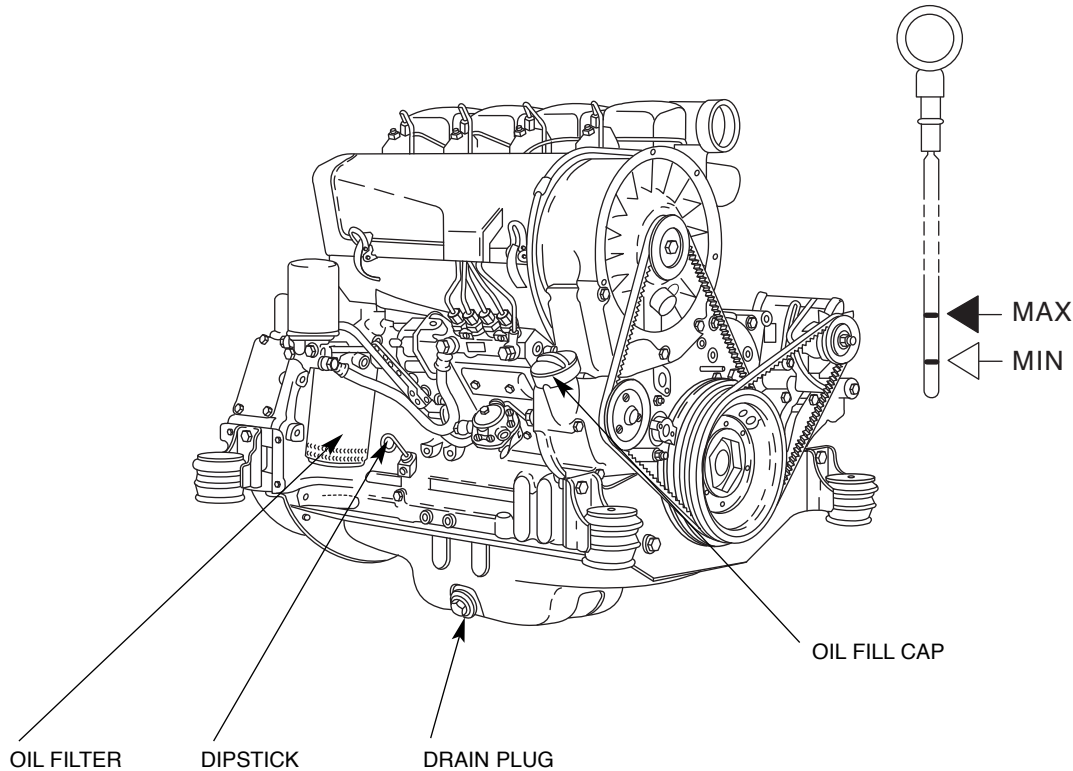

CHANGE THE OIL FILTER: Change the oil filter the first time between 25 and 50 hours of operation. Then, under normal operating conditions, change the oil filter after every 250 hours of operation. If the engine is operated under heavy load or in high ambient temperatures, change the oil filter more frequently. See **Table D1.1** for recommended maintenance intervals. See **Table D1.2** for replacement oil filters.

Change the oil filter as follows:

1. Remove the oil drain plug. Drain the oil from the engine and allow the oil filter to drain. See Figure D1.1.
2. Remove the old filter (spin it off) and discard it. Wipe off the filter mounting surface and adapter. See Figure D1.1.
3. Fill the new filter with fresh engine oil. Apply a thin coat of new oil to the rubber gasket on the new oil filter.
4. Spin the new filter onto the mounting adapter finger tight until the gasket is evenly seated. Then turn it down another 1/2 turn. Do not overtighten the new filter.

5. Refill the engine with the proper amount and type of oil as described in the **Change the Oil** section, above. Start the engine and check for leaks around the filter element. Correct any leaks (usually by retightening the filter, but only enough to stop leaks) before placing the Vantage 500 back in service.
6. If there are no leaks, stop the engine and recheck the oil level. If necessary, add oil to bring the level up to the "MAX" mark, but do not overfill. See Figure D1.1.

FUEL

At the end of each day's use, refill the fuel tank to minimize moisture condensation and dirt contamination in the fuel line. Do not overfill; leave room for the fuel to expand.

Refer to your engine operation manual for recommended grade of fuel.

FUEL FILTERS:

WARNING

When working on the fuel system:

- Keep naked lights away, do not smoke
- Do not spill fuel

The Vantage® 500 is equipped with a **Fuel Pre-Filter/Water Separator Assembly** located before the lift pump and a **Secondary Fuel Filter** located after the lift pump and before the fuel injectors. The Fuel Pre-Filter/Water Separator is mounted to the engine block just below the lift pump (Figure D.2). The Secondary Fuel Filter is mounted directly to the engine just above the oil filter (**Figure D1.3**).

Fuel Pre-Filter/Water Separator Assembly:

The pre-filter is a 150 micron screen designed to protect against gross fuel contamination of the water separator element and the Secondary Fuel Filter. If the pre-filter becomes plugged, it may be removed, inspected, cleaned and reinstalled. In general this only needs to be done with each water separator element change (about every 1,000 hrs). However, if at any time excessive fuel contamination is suspected or a sudden fall-off in engine performance is detected the pre-filter screen should be inspected and cleaned. See Figure D.2 and follow this procedure:

1. Close the fuel shutoff valve located on the side of the Fuel Pre-Filter/Water Separator Assembly. The lever should be perpendicular to the hose
2. Unscrew the cap ring located on the top of the filter header and remove the plastic center cap and O-ring.
3. Remove the large white volume plug located directly under the center cap in the upper cavity of the filter header. Use a small screwdriver (or similar device) to lift the plug part way out of the cavity to assist with its removal.

NOTE: Be careful not to damage the pre-filter screen with the tool used to remove the plug.

4. Using a pair of pliers, gently tug on the pull tabs of the pre-filter screen in an alternating pattern to gradually remove the pre-filter screen.
5. Brush off any debris and rinse in diesel fuel.
6. Re-install the pre-filter screen into the upper cavity of the filter header making sure the four pull tabs are pointing up. Putting your fingers on the pull tabs, push down evenly until the lower body of the pre-filter screen contacts the floor of the upper cavity.

7. Re-insert the large white volume plug into the upper cavity.
8. Place the O-ring onto the angled seal surface of the filter header and re-install the plastic cap. Make sure its flange rests on the O-ring.
9. Screw on the cap ring and tighten hand tight.
10. Remember to open the fuel shutoff valve (Lever in line with the hose) before starting the engine.

Water Separator Element: The water separator element is a two-stage filter with a special filtration/water separating media. An expanded water reservoir provides maximum protection against water in the fuel. The recommended change interval for the water separator element is 1,000 hours. See Figure D.2 and follow this procedure.

1. Close the fuel shutoff valve located on the side of the Fuel Pre-Filter/Water Separator Assembly. The lever should be perpendicular to the hose.
2. Rotate the quick change ring (located just below filter header) clockwise approximately 1/2 turn and slide it down and off the element.
3. Grasp the element and pull down with a slight rocking motion to remove the element from the grommet post on the bottom of the filter header.

FIGURE D1.2 – FUEL PRE-FILTER/WATER SEPARATOR ASSEMBLY

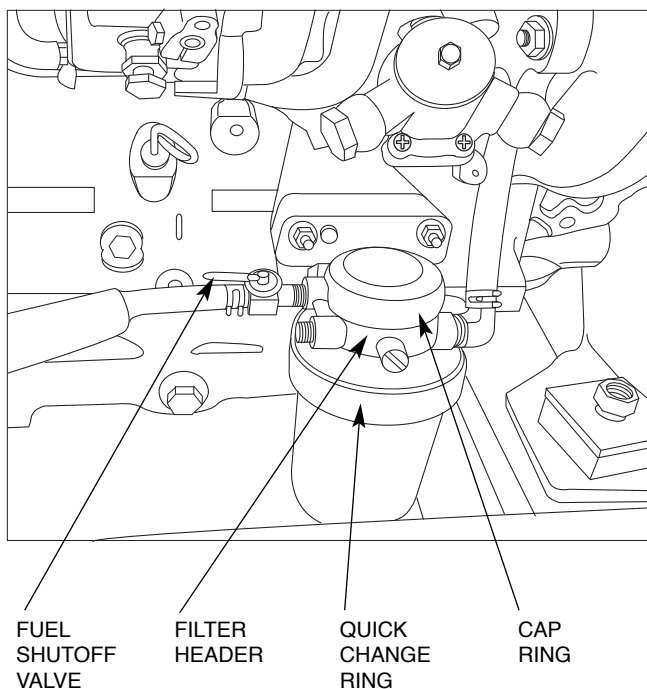

4. Slide the new element onto the grommet post on the bottom of the filter header until the element no longer easily moves up into the filter header. Now rotate the element (it may take almost 1 full turn) with a slight upward pressure until the element begins to further engage the header. With the proper orientation now established, apply additional pressure to seat the element in the filter header. You should feel the element “pop” into place when properly seated.

NOTE: The element will only go on one way. Never use excessive force when mounting the element to the header.

5. Slide the quick change ring up over the element and rotate counter clockwise until an audible click or pop is heard. If you do not hear the click, you have not rotated the ring far enough and the element is not in the locked position. Another indication that the ring is in the locked position is that one set (it doesn't matter which one) of arrows located on the outside of the ring should be located directly under the air vent valve.

6. Open the fuel shutoff valve (lever in line with the hose).

7. Open the air vent valve on the front of the filter header until fuel emerges free of air bubbles. Then close the air vent valve.

Secondary Fuel Filter: The Secondary Fuel Filter is a spin-on cartridge type mounted directly to the engine. Consult your engine Operator's Manual for complete information on service intervals and element changing procedures.

FIGURE D1.3 – SECONDARY FUEL FILTER

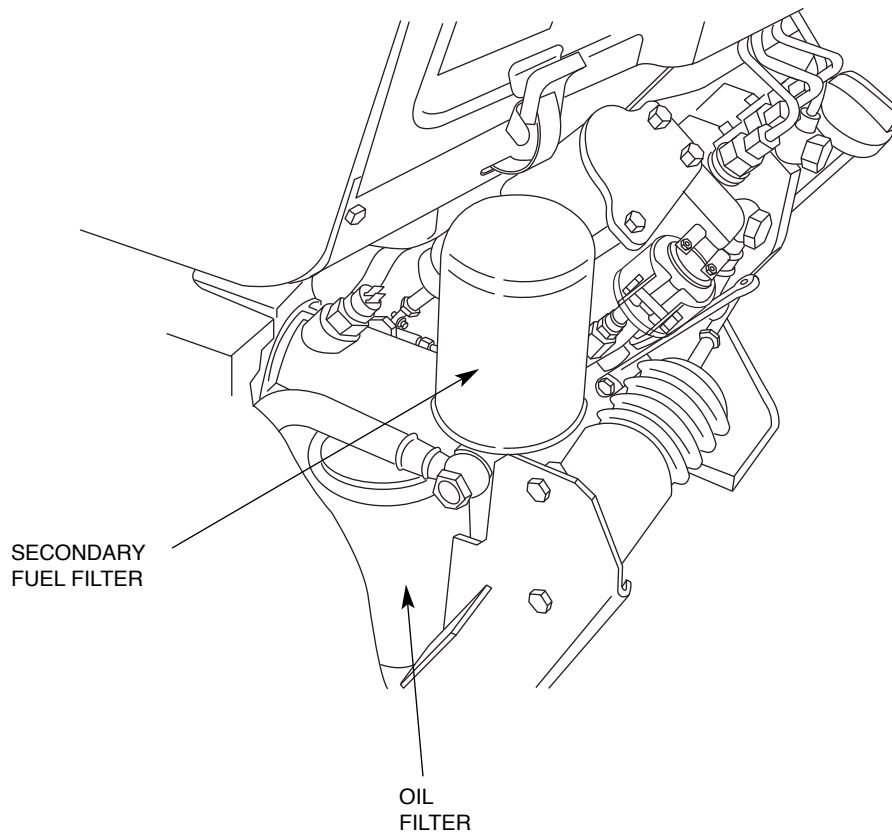

BLEEDING THE FUEL SYSTEM: In the event the engine is operated until it runs out of fuel, you will need to bleed the fuel system in order to start the engine. Refer to the engine operation manual.

AIR FILTER

CAUTION

Excessive air filter restriction will result in reduced engine life.

The air filter element is a dry cartridge type. It can be cleaned and reused. However, damaged elements should not be reused. Stop engine after 100 hours of running time and clean filter element. Replace the filter if necessary. Service the air cleaner regularly according to your engine operation manual.

1. Locate the air filter canister located behind the engine door on the top of the engine.
2. Remove the air filter element.

3. Remove loose dirt from the element with compressed air or a water hose directed from inside out.

Compressed Air: 100 psi maximum with nozzles at least one inch away from the element.

Water Hose: 40 psi maximum without nozzle.

4. Soak the element in a mild detergent solution for 15 minutes. Do not soak more than 24 hours. Swish the element around in the solution to help remove dirt.
5. Rinse elements from inside out with a gentle stream of water (less than 40 psi) to remove all suds and dirt.
6. Dry the element before reuse with warm air at less than 160°F (71°C). Do not use a light bulb to dry the element.
7. Inspect for holes and tears by looking through the element toward a bright light. Check for damaged gaskets or dented metal parts. Do not reuse damaged elements. Protect the element from dust and damage during drying and storage.
8. Reinstall the air filter element.

After six cleanings, replace the air filter. A cleaned filter will have approximately 70% of the life of a new filter element. A restricted filter element may not appear excessively dirty.

MAINTENANCE INSTRUCTIONS

Service Instructions

Single- and Two-Stage Engine Air Cleaners

1 Remove the Filter

Rotate the filter while pulling straight out.

Unfasten or unlatch the service cover. Because the filter fits tightly over the outlet tube to create the critical seal, there will be some initial resistance, similar to breaking the seal on a jar. Gently move the end of the filter back and forth to break the seal then rotate while pulling straight out. Avoid knocking the filter against the housing.

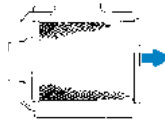

If your air cleaner has a safety filter, replace it every third primary filter change. Remove the safety filter as you would the primary filter. Make sure you cover the air cleaner outlet tube to avoid any unfiltered contaminant dropping into the engine.

2 Clean Both Surfaces of the Outlet Tube and Check the Vacuator™ Valve

Use a clean cloth to wipe the filter sealing surface and the inside of the outlet tube. Contaminant on the sealing surface could hinder an effective seal and cause leakage. Make sure that all contaminant is removed before the new filter is inserted. Dirt accidentally transferred to the inside of the outlet tube will reach the engine and cause wear. Engine manufacturers say that it takes only a few grams of dirt to "dust" an engine! Be careful not to damage the sealing area on the tube.

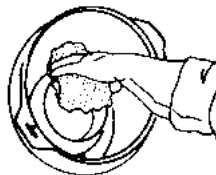

Outer edge of the outlet tube

Wipe both sides of the outlet tube clean.

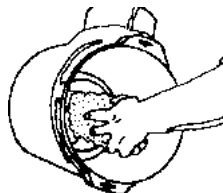

Inner edge of the outlet tube

If your air cleaner is equipped with a Vacuator Valve Visually check and physically squeeze to make sure the valve is flexible and not inverted, damaged or plugged.

**3 Inspect the Old Filter for Leak Clues**

Visually inspect the old filter for any signs of leaks. A streak of dust on the clean side of the filter is a telltale sign. Remove any cause of leaks before installing new filter.

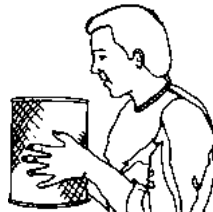
**4 Inspect the New Filter for Damage**

Inspect the new filter carefully, paying attention to the inside of the open end, which is the sealing area. NEVER install a damaged filter. A new Donaldson radial seal filter may have a dry lubricant on the seal to aid installation.

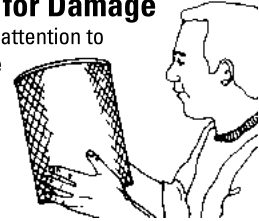
**5 Insert the New Radial Seal Filter Properly**

If you're servicing the safety filter, this should be seated into position before installing the primary filter.

Insert the new filter carefully. Seat the filter by hand, making certain it is completely into the air cleaner housing before securing the cover in place.

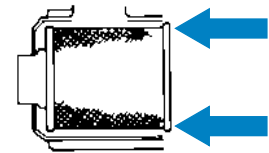

The critical sealing area will stretch slightly, adjust itself and distribute the sealing pressure evenly. To complete a tight seal, apply pressure by hand at the outer rim of the filter, not the flexible center. (Avoid pushing on the center of the urethane end cap.) No cover pressure is required to hold the seal. NEVER use the service cover to push the filter into place! Using the cover to push the filter in could cause damage to the housing, cover fasteners and will void the warranty.

If the service cover hits the filter before it is fully in place, remove the cover and push the filter (by hand) further into the air cleaner and try again. The cover should go on with no extra force.

Once the filter is in place, secure the service cover.

**Caution**

NEVER use the service cover to push the filter into place! Using the cover to push the filter in could cause damage to the housing, cover fasteners and will void the warranty.

**6 Check Connectors for Tight Fit**

Make sure that all mounting bands, clamps, bolts, and connections in the entire air cleaner system are tight. Check for holes in piping and repair if needed. Any leaks in your intake piping will send dust directly to the engine!

COOLING SYSTEM

The cooling system of the Deutz engine needs to be checked and cleaned periodically. Consult the engine Operation Manual for the proper frequency and procedure.

COOLING BLOWER BELT: The following procedure should be followed to replace the cooling blower belt:

1. Allow the machine to cool.
2. Unfasten and slide the battery holder out from the welder.
3. Disconnect the negative battery cable.
4. Remove the engine case side.
5. Loosen the air cleaner hose clamp and detach the hose.
6. Remove the engine end panel with air box and air cleaner attached for access to the engine.
7. See Figure D1.4. Loosen the alternator mounting bolts (1, 2, 3) and rotate the alternator toward the engine.
8. Remove the old cooling blower belt and install a new one.
9. Push outward on the alternator (4) and adjust the cold belt tension to 63-73 lbs (10-15 mm maximum deflection) midway between any two pulleys. Tighten bolts (1), (2), (3).
10. Reinstall the air cleaner hose, engine case side, and engine end panel. Reattach the negative battery cable. Slide in and refasten the battery holder.
11. Check the cooling blower belt tension after 100 hours of operation. (Follow steps 1-6; 9 and 10.)

FIGURE D1.4 – COOLING BLOWER BELT REPLACEMENT AND ADJUSTING

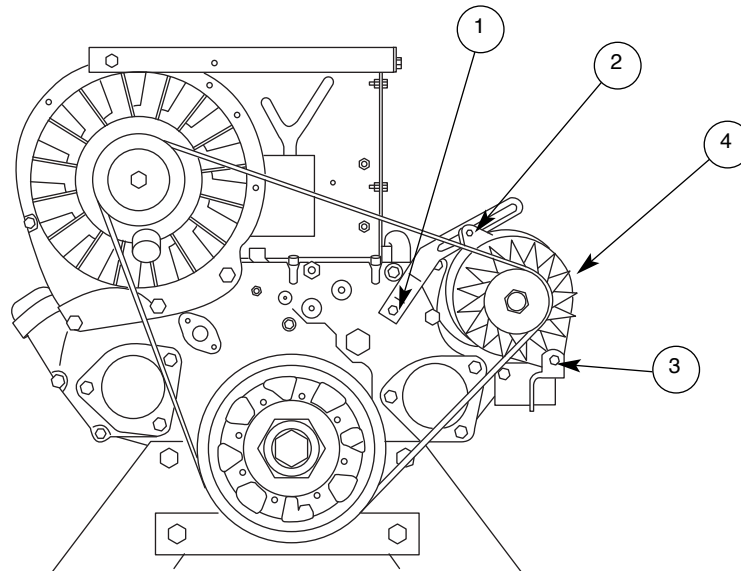

**TABLE D1.1
DEUTZ ENGINE MAINTENANCE SCHEDULE**

FREQUENCY	MAINTENANCE REQUIRED
Daily or Before Starting Engine	<ul style="list-style-type: none"> • Fill fuel tank. • Check oil level. • Check air cleaner for dirty, loose, or damaged parts. Replace if necessary. • Check air intake and cooling areas, clean as necessary.
¹First 50 Hours and Every 250 Hours Thereafter	<ul style="list-style-type: none"> • Change engine oil. • Change oil filter. • Change fuel filter. • Check fan belt.
Every 50 Hours	<ul style="list-style-type: none"> • Check fuel lines and clamps.
Every 100 Hours	<ul style="list-style-type: none"> • Check battery electrolyte level and connections. • Clean air filter.

Refer to your Deutz engine operation manual for periodic maintenance at 100 hours and beyond.

¹125 Hours for severe conditions.

**TABLE D1.2
ENGINE MAINTENANCE PARTS**

ITEM	MANUFACTURER	PART NUMBER
Air Cleaner Element	Donaldson AC	P181052 A302C
Cooling Blower Belt	Lincoln Gates	T13536-3 7585
Oil Filter Element	Deutz Purolator Napa Fram	1174418 PER2168 1820 PH3776
Fuel Filter Element	Deutz Purolator Napa Fram	1174423 PC42 3358 P4102
Water Separator Element	Lincoln Stanadyne	M16890-C 31572
Fuel Pre-Filter Screen	Lincoln Stanadyne	M16890-B 29575
Battery		BCI Group 34

VANTAGE® 500



BATTERY MAINTENANCE

 **WARNING**

GASES FROM BATTERY can explode.

- Keep sparks, flame, and cigarettes away from battery.



BATTERY ACID can burn eyes and skin.

- Wear gloves and eye protection and be careful when working near a battery. Follow the instructions printed on the battery.



To prevent **EXPLOSION** when:

- **INSTALLING A NEW BATTERY -** Disconnect the negative cable from the old battery first and connect to the new battery last.
- **THE CORRECT POLARITY IS NEGATIVE GROUND -** Damage to the engine alternator and the printed circuit board can result from incorrect connection.
- **CONNECTING A BATTERY CHARGER -** Remove the battery from the welder by disconnecting the negative cable first, then the positive cable and battery clamp. When reinstalling, connect the negative cable last. Keep the area well ventilated.
- **USING A BOOSTER -** Connect the positive lead to the battery first, then connect the negative lead to the engine foot.
- To prevent **BATTERY BUCKLING**, tighten the nuts on the battery clamp until snug.

CLEANING THE BATTERY: Keep the battery clean by wiping it with a damp cloth when dirty. If the terminals appear corroded, disconnect the battery cables and wash the terminals with an ammonia solution or a solution of 1/4 pound (0.113 kg) of baking soda and 1 quart (0.946 l) of water. Be sure the battery vent plugs (if equipped) are tight so that none of the solution enters the cells.

After cleaning, flush the outside of the battery, the battery compartment, and surrounding areas with clear water. Coat the battery terminals lightly with petroleum jelly or a non-conductive grease to retard corrosion.

Keep the battery clean and dry. Moisture accumulation on the battery can lead to more rapid discharge and early battery failure.

CHECKING SPECIFIC GRAVITY: Check each battery cell with a hydrometer. A fully charged battery will have a specific gravity of 1.260. Charge the battery if the reading is below 1.215.

NOTE: Correct the specific gravity reading by adding four gravity points (0.004) for every five degrees the electrolyte temperature is above 80 degrees F (27 degrees C). Subtract four gravity points (.004) for every five degrees the electrolyte temperature is below 80 degrees F (27 degrees C).

CHECKING ELECTROLYTE LEVEL: If battery cells are low, fill them to the neck of the filler hole with distilled water and recharge. If one cell is low, check for leaks.

CHARGING THE BATTERY: The Vantage® 500 is equipped with a wet charged battery. The charging current is automatically regulated when the battery is low (after starting the engine) to a trickle current when the battery is fully charged.

When you charge, jump, replace, or otherwise connect battery cables to the battery, be sure the polarity is correct. Improper polarity can damage the charging circuit. **The Vantage® 500 charging system is NEGATIVE GROUND.** The positive (+) battery terminal has a red terminal cover.

If you need to charge the battery with an external charger, disconnect the negative cable first, then the positive cable before you attach the charger leads. After the battery is charged, reconnect the positive battery cable first and the negative cable last. Failure to do so can result in damage to the internal charger components.

Follow the instructions of the battery charger manufacturer for proper charger settings and charging time.

**WELDER/GENERATOR
MAINTENANCE**

STORAGE: Store the Vantage 500 in clean, dry, protected areas.

CLEANING: Blow out the generator and controls periodically with low pressure air. Do this at least once a week in particularly dirty areas.

NAMEPLATES: Whenever routine maintenance is performed on this machine - or at least yearly - inspect all nameplates and labels for legibility. Replace those which are no longer clear. Refer to the parts list for the replacement item number.

BRUSH REMOVAL AND REPLACEMENT: It is normal for the brushes and slip rings to wear and darken slightly. Inspect the brushes when a generator overhaul is necessary.

BEARINGS: The Vantage 500 is equipped with double-shielded ball bearings having sufficient grease to last indefinitely under normal service. Where the welder is used constantly or in excessively dirty locations, it may be necessary to add one half ounce of grease per year. A pad of grease one inch wide, one inch long, and one inch high weighs approximately one half ounce. Over-greasing is far worse than insufficient greasing.

When greasing the bearings, keep all dirt out of the area. Wipe the fittings completely clean and use clean equipment. More bearing failures are caused by dirt introduced during greasing than from insufficient grease.

RECEPTACLES: Keep the electrical receptacles in good condition. Remove any dirt, oil, or other debris from their surfaces and holes.

CABLE CONNECTIONS: Check the welding cable connections at the weld output terminals often. Be sure that the connections are always tight.

 **WARNING**

Do not attempt to polish slip rings while the engine is running.

Return to Section TOC
Return to Master TOC
Return to Section TOC
Return to Master TOC
Return to Section TOC
Return to Master TOC
Return to Section TOC
Return to Master TOC

FIGURE D1.5 – MAJOR COMPONENT LOCATIONS

- | | |
|----------------------------------|------------------------|
| 1. CONTROL PANEL ASSEMBLY | 6. ENGINE ASSEMBLY |
| 2. CONTROL BOX & OUTPUT ASSEMBLY | 7. GENERATOR |
| 3. POWER MODULE ASSEMBLY | 8. SOLENOID ASSEMBLY |
| 4. BASE & LIFT BALE ASSEMBLY | 9. CASEBACK |
| 5. FUEL TANK & MOUNTING | 10. CASE TOP AND SIDES |

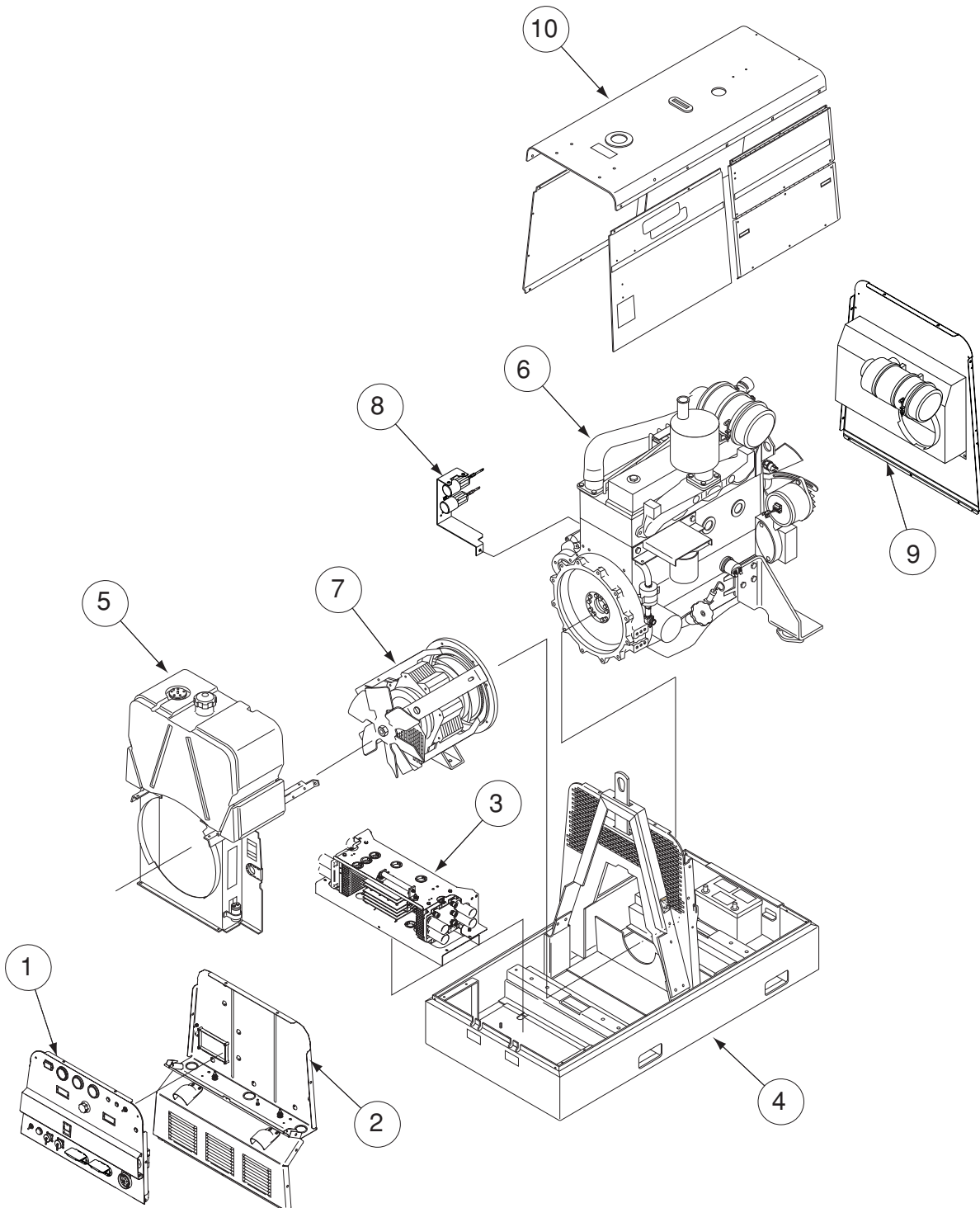

VANTAGE® 500

Installation - VANTAGE® 500 Deutz F4L2011 (Codes 11180,11415)

Technical Specifications	A2.2
Safety Precautions	A2.3
Location/Ventilation	A.3
Storing	A2.3
Stacking	A2.3
Angle of Operation	A2.3
Lifting	A2.4
High Altitude Operation	A2.4
High Temperature Operation	A2.4
Towing	A2.4
Vehicle Mounting	A2.4
Pre-Operation Engine Service	A2.5
Oil	A2.5
Fuel	A2.5
Fuel Cap	A2.5
Engine Cooling System	A2.5
Battery Connection	A2.5
Muffler Outlet Pipe	A2.6
Spark Arrester	A2.6
High Frequency Generators for TIG Applications	A2.6
Electrical Connections	A2.6
Remote Control	A2.6
Welding Terminals	A2.6
Welding Output Cables	A2.7
Machine Grounding	A2.7
Auxiliary Power Receptacles	A2.7
Standby Power Connections	A2.7

TECHNICAL SPECIFICATIONS - VANTAGE 500 DEUTZ (K2405-1)

INPUT - DIESEL ENGINE

Make /Model	Description	Speed (RPM)	Displacement	Starting System	Capacities
DEUTZ F4L2011 Diesel Engine	4 cylinder 48HP (36 kw) @ 1800 RPM	High Idle 1890 Low Idle 1425 Full Load 1800	190 cu. in (3.1L) Bore x Stroke 3.70" x 4.41" (94mm x 112mm)	12VDC battery & Starter	Fuel 25 US gal. (94.6L) Oil: 2.5 US gal. (9.5L)

RATED OUTPUT @ 104°F(40°C) - WELDER

Duty Cycle	Welding Output	Volts at Rated Amps
100%	500 Amps (DC multi-purpose)	40 Volts
60%	550 Amps (DC multi-purpose)	36 volts
50%	575 Amps (DC multi-purpose)	35 volts

OUTPUT @ 104°F(40°C) - WELDER AND GENERATOR

Welding Range

30 - 575 Amps CC/CV
20 - 250 Amps TIG

Open Circuit Voltage

60 Max OCV @ 1900 RPM

Auxiliary Power ⁽¹⁾

120/240 VAC
12,000 WATTS, 60 Hz., Single Phase
20,000 WATTS, 60 Hz., Three Phase

PHYSICAL DIMENSIONS

Height ⁽²⁾	Width	Depth	Weight
42.0 in (1066.8 mm)	31.5 in. (800.1mm)	63.1 in. (1603mm)	1532lbs. (695kg) (Approx)

- Output rating in watts is equivalent to volt-amperes at unity power factor.
Output voltage is within +/- 10% at all loads up to rated capacity. When welding, available auxiliary power will be reduced.
- Top of Enclosure. Add 8.9" (226mm) for exhaust.

VANTAGE® 500



Read this entire installation section before you start installation.

SAFETY PRECAUTIONS



WARNING

Do not attempt to use this equipment until you have thoroughly read all operating and maintenance manuals supplied with your machine. They include important safety precautions, \detailed engine starting, operating and maintenance instructions and parts lists.

ELECTRIC SHOCK can kill.



- Do not touch electrically live parts such as output terminals or internal wiring.
- Insulate yourself from the work and ground.
- Always wear dry insulating gloves.

ENGINE EXHAUST can kill.



- Use in open, well ventilated areas or vent exhaust outside
- Do not stack anything near the engine.

MOVING PARTS can injure.



- Do not operate with doors open or guards off.
- Stop engine before servicing.
- Keep away from moving parts

Only qualified personnel should install, use or service this equipment

LOCATION / VENTILATION

The welder should be located to provide an unrestricted flow of clean, cool air to the cooling air inlets and to avoid restricting the cooling air outlets. Also, locate the welder so that the engine exhaust fumes are properly vented to an outside area.



CAUTION

DO NOT MOUNT OVER COMBUSTIBLE SURFACES

Where there is a combustible surface directly under stationary or fixed electrical equipment, that surface should be covered with a steel plate at least .06”(1.6mm) thick, which should extend not less than 5.90”(150mm) beyond the equipment on all sides.

STORING

1. Store the machine in a cool, dry place when it is not in use. Protect it from dust and dirt. Keep it where it can't be accidentally damaged from construction activities, moving vehicles, and other hazards.
2. Drain the engine oil and refill with fresh 10W30 oil. Run the engine for about five minutes to circulate oil to all the parts. See the **MAINTENANCE** section of this manual for details on changing oil.
3. Remove the battery, recharge it, and adjust the electrolyte level. Store the battery in a dry, dark place.

STACKING

Vantage 500 machines cannot be stacked.

ANGLE OF OPERATION

To achieve optimum engine performance the Vantage should be run in a level position. The maximum angle of operation for the Cummins engine is 35 degrees in all directions. If the engine is to be operated at an angle, provisions must be made for checking and maintaining the oil level at the normal (FULL) oil capacity in the crankcase. When operating the welder at an angle, the effective fuel capacity will be slightly less than the specified 25 gallons.

LIFTING

The Vantage lift bale should be used to lift the machine. The Vantage is shipped with the lift bale retracted. Before attempting to lift the Vantage, secure the lift bale in a raised position. Secure the lift bale as follows:

- Open the engine compartment door.
- Locate the two access holes on the upper middle region of the compartment wall just below the lift bale.
- Use the lifting strap to raise the lift bale to the full upright position. This will align the mounting holes on the lift bale with the access holes.
- Secure the lift bale with 2 thread forming screws. The screws are provided in the loose parts bag shipped with the machine.

WARNING

FALLING EQUIPMENT can cause injury.



- Do not lift this machine using lift bale if it is equipped with a heavy accessory such as a trailer or gas cylinder.
- Lift only with equipment of adequate lifting capacity.
- Be sure machine is stable when lifting.

HIGH ALTITUDE OPERATION

At higher altitude, output derating may be necessary. For maximum rating, derate the welder output 5% for every 300 meters (984 ft.) above 1500 meters (4920 ft.). For output of 500A and below, derate the welder output 5% for every 300 meters (984 ft.) above 2100 meters (6888 ft.)

Contact a Deutz Service Representative for any engine adjustments that may be required.

HIGH TEMPERATURE OPERATION

At temperatures above 30°C (86°F), output voltage derating is necessary. For maximum output current ratings, derate the welder voltage rating two volts for every 10°C (21°F) above 30°C (86°F).

TOWING

The recommended trailer for use with this equipment for road, in-plant and yard towing by a vehicle¹ is Lincoln's K953-1. If the user adapts a non-Lincoln trailer, he must assume responsibility that the method of attachment and usage does not result in a safety hazard nor damage the welding equipment. Some of the factors to be considered are as follows:

- Design capacity of the trailer vs. weight of the Lincoln equipment and likely additional attachments.
- Proper support of, and attachment to, the base of the welding equipment so that there will be no undue stress to the trailer's framework.
- Proper placement of the equipment on the trailer to insure stability side to side and front to back when being moved and when standing by itself.
- Typical conditions of use, such as travel speed, roughness of surface on which the trailer will be operated, and environmental conditions.
- Proper preventative maintenance of the trailer.
- Conformance with federal, state and local laws.¹

¹Consult applicable federal, state and local laws regarding specific requirements for use on public highways.

VEHICLE MOUNTING

WARNING

Improperly mounted concentrated loads may cause unstable vehicle handling and tires or other components to fail.

- Only transport this Equipment on serviceable vehicles which are rated and designed for such loads.
- Distribute, balance and secure loads so vehicle is stable under conditions of use.
- Do not exceed maximum rated loads for components such as suspension, axles and tires.
- Mount equipment base to metal bed or frame of vehicle.
- Follow vehicle manufacturer's instructions.

PRE-OPERATION ENGINE SERVICE

READ the engine operating and maintenance instructions supplied with this machine.

WARNING



- Keep hands away from the engine muffler or HOT engine parts.
- Stop engine and allow to cool before fueling.
- Do not smoke when fueling.
- Fill fuel tank at a moderate rate and do not overfill.
- Wipe up spilled fuel and allow fumes to clear before starting engine.
- Keep sparks and flame away from tank.

OIL



The Vantage is shipped with the engine crankcase filled with high quality SAE 10W-30 oil (API class CD or better). Check the oil level before starting the engine. If it is not up to the full mark on the dip stick, add oil as required. Check the oil level every four hours of running time during the first 35 running hours. Refer to the engine Operator's Manual for specific oil recommendations and break-in information. The oil change interval is dependent on the quality of the oil and the operating environment. Refer to the engine Operator's Manual for the proper service and maintenance intervals.

FUEL

NOTE: USE DIESEL FUEL ONLY. Fill the fuel tank with clean, fresh diesel fuel. The capacity of the fuel tank is approx 95 liters. See engine Operator's Manual for specific fuel recommendations. **Running out of fuel may require bleeding the fuel injection pump.** **NOTE:** Before starting the engine, open the fuel shut-off valve (pointer to be in line with hose).

FUEL CAP

Remove the plastic cap covering from the fuel tank filler neck and install the fuel cap.

ENGINE COOLING SYSTEM

The Deutz engine is air cooled by a belt-driven axial blower. The oil cooler and engine cooling fins should be blown out with compressed air or steam to maintain proper cooling. (See the engine Operator's Manual for procedures and frequency.)

BATTERY CONNECTION



WARNING

GASES FROM BATTERY can explode.

- Keep sparks, flame and cigarettes away from battery.

To prevent EXPLOSION when:



- **INSTALLING A NEW BATTERY** — disconnect negative cable from old battery first and connect to new battery last.
- **CONNECTING A BATTERY CHARGER** — remove battery from welder by disconnecting negative cable first, then positive cable and battery clamp. When reinstalling, connect negative cable last. Keep well ventilated.
- **USING A BOOSTER** — connect positive lead to battery first then connect negative lead to negative battery lead at engine foot.

BATTERY ACID can burn eyes and skin.



- Wear gloves and eye protection and be careful when working near battery.
- Follow instructions printed on battery.

IMPORTANT: To prevent ELECTRICAL DAMAGE WHEN:

- a) Installing new batteries
- b) Using a booster

Use correct polarity — **Negative Ground.**

The Vantage is shipped with the negative battery cable disconnected. Before you operate the machine, make sure the Engine Switch is in the OFF position and attach the disconnected cable securely to the negative (-) battery terminal.

Remove the insulating cap from the negative battery terminal. Replace and tighten the negative battery cable terminal.

NOTE: This machine is furnished with a wet charged battery; if unused for several months, the battery may require a booster charge. Be sure to use the correct polarity when charging the battery.

MUFFLER OUTLET PIPE

Remove the plastic plug covering the muffler outlet tube. Using the clamp provided, secure the outlet pipe to the outlet tube with the pipe positioned to direct the exhaust in the desired direction.

SPARK ARRESTER

Some federal, state or local laws may require that gasoline or diesel engines be equipped with exhaust spark arresters when they are operated in certain locations where unarrested sparks may present a fire hazard. The standard muffler included with this welder does not qualify as a spark arrester. When required by local regulations, a suitable spark arrester must be installed and properly maintained.



CAUTION

An incorrect arrester may lead to damage to the engine or adversely affect performance.

HIGH FREQUENCY GENERATORS FOR TIG APPLICATIONS

The K799 Hi-Freq Unit (obsolete) and the K930-1 or-2 TIG Module are suitable for use with the Vantage 500. The Vantage 500 is equipped with the required R.F. bypass circuitry for the connection of high frequency generating equipment. The high frequency bypass network supplied with the K799 Hi-Freq Unit does NOT need to be installed into the Vantage 500.

The Vantage 500 and any high frequency generating equipment must be properly grounded. See the K799 Hi-Freq Unit and the K930-1 or-2 TIG Module operating manuals for complete instructions on installation, operation, and maintenance.

ELECTRICAL CONNECTIONS

REMOTE CONTROL

The Vantage 500 is equipped with a 6-pin and a 14-pin connector. The 6-pin connector is for connecting the K857 or K857-1 Remote Control (optional) or, in the case of TIG welding applications, with the foot or hand Amptrol (K870 or K963-1 respectively).

The 14-pin connector is used to directly connect a wire feeder or TIG Module (K930-1 or-2) control cable.

NOTE: When using the 14-pin connector, if the wire feeder has a built-in power source output control, do not connect anything to the 6-pin connector.

WELDING TERMINALS

The Vantage is equipped with a toggle switch for selecting "hot" welding terminals when in the "WELD TERMINALS ON" position or "cold" welding terminals when in the "WELDING TERMINALS REMOTELY CONTROLLED" position.

WELDING OUTPUT CABLES

With the engine off, route the electrode and work cables through the strain relief bracket provided on the front of the base and connect to the terminals provided. These connections should be checked periodically and tightened if necessary.

Listed in Table A2.1 are copper cable sizes recommended for the rated current and duty cycle. Lengths stipulated are the distance from the welder to work and back to the welder again. Cable sizes are increased for greater lengths primarily for the purpose of minimizing cable voltage drop.

TABLE A2.1 – COMBINED LENGTH OF ELECTRODE AND WORK CABLES

Amps @ 100% Duty Cycle	Total Combined Length of Electrode and Work Cables		
	Up to 150 ft.	150-200 ft.	200-250 ft.
500	3/0 AWG	3/0 AWG	4/0 AWG

MACHINE GROUNDING

Because this portable engine driven welder creates its own power, it is not necessary to connect its frame to an earth ground, unless the machine is connected to premises wiring (home, shop, etc.).

To prevent dangerous electric shock, other equipment powered by this engine driven welder must:

- a) be grounded to the frame of the welder using a grounded type plug,

or

- b) be double insulated.

When this welder is mounted on a truck or trailer, its frame must be securely connected to the metal frame of the vehicle. When this engine driven welder is connected to premises wiring such as that in a home or shop, its frame must be connected to the system earth ground. See further connection instructions in the section entitled **Standby Power Connections** as well as the article on grounding in the latest U.S. National Electrical Code and the local code.

In general, if the machine is to be grounded, it should be connected with a #8 or larger copper wire to a solid earth ground such as a metal water pipe going into the ground for at least ten feet and having no insulated joints, or to the metal framework of a building which has been effectively grounded. The U.S. National Electrical Code lists a number of alternate means of grounding electrical equipment. A machine grounding stud marked with the \oplus symbol is provided on the front of the welder.

AUXILIARY POWER RECEPTACLES

The auxiliary power capacity of the Vantage 500 is 12,000 watts of 60 Hz, single-phase power. The auxiliary power capacity rating in watts is equivalent to volt-amperes at unity power factor. The maximum permissible current of the 240 VAC output is 50 A. The 240 VAC output can be split to provide two separate 120 VAC outputs with a maximum permissible current of 50 A per output to two separate 120 VAC branch circuits. The output voltage is within $\pm 10\%$ at all loads up to rated capacity.

NOTE: The 120/240V receptacle has two 120V outlets of different phases and cannot be paralleled.

The Vantage has two 20A-120VAC (5-20R) duplex receptacles and one 50A-120/240 VAC (14-50R) receptacle. The 120/240 VAC receptacle can be split for single-phase 120 VAC operation. The auxiliary power receptacles should only be used with three-wire grounded type plugs or approved double insulated tools with two-wire plugs. The current rating of any plug used with the system must be at least equal to the current capacity of the associated receptacle.

STANDBY POWER CONNECTIONS

The Vantage 500 is suitable for temporary, standby or emergency power using the engine manufacturer's recommended maintenance schedule.

The Vantage 500 can be permanently installed as a standby power unit for 240 volt, three-wire, 50 amp service. Connections must be made by a licensed electrician who can determine how the 120/240 VAC power can be adapted to the particular installation and comply with all applicable electrical codes. The following information can be used as a guide by the electrician for most applications. Refer to the connection diagram shown in **Figure A2.1**.

1. Install the double-pole, double-throw switch between the power company meter and the premises disconnect.

Switch rating must be the same or greater than the customer's premises disconnect and service over current protection.

2. Take necessary steps to assure load is limited to the capacity of the Vantage by installing a 50 amp, 240 VAC double-pole circuit breaker. Maximum rated load for each leg of the 240 VAC auxiliary is 50 amperes. Loading above the rated output will reduce output voltage below the allow-

able -10% of rated voltage, which may damage appliances or other motor-driven equipment and may result in overheating of the Vantage 500 engine.

3. Install a 50 amp 120/240 VAC plug (NEMA Type 14-50) to the double-pole circuit breaker using four-conductor cable of the proper size and desired length. (The 50 amp, 120/240 VAC plug is available in the optional K802R plug kit.)
4. Plug this cable into the 50 amp 120/240 volt receptacle on the Vantage 500 case front.

Figure A2.1 Connection of the Vantage to Premises Wiring

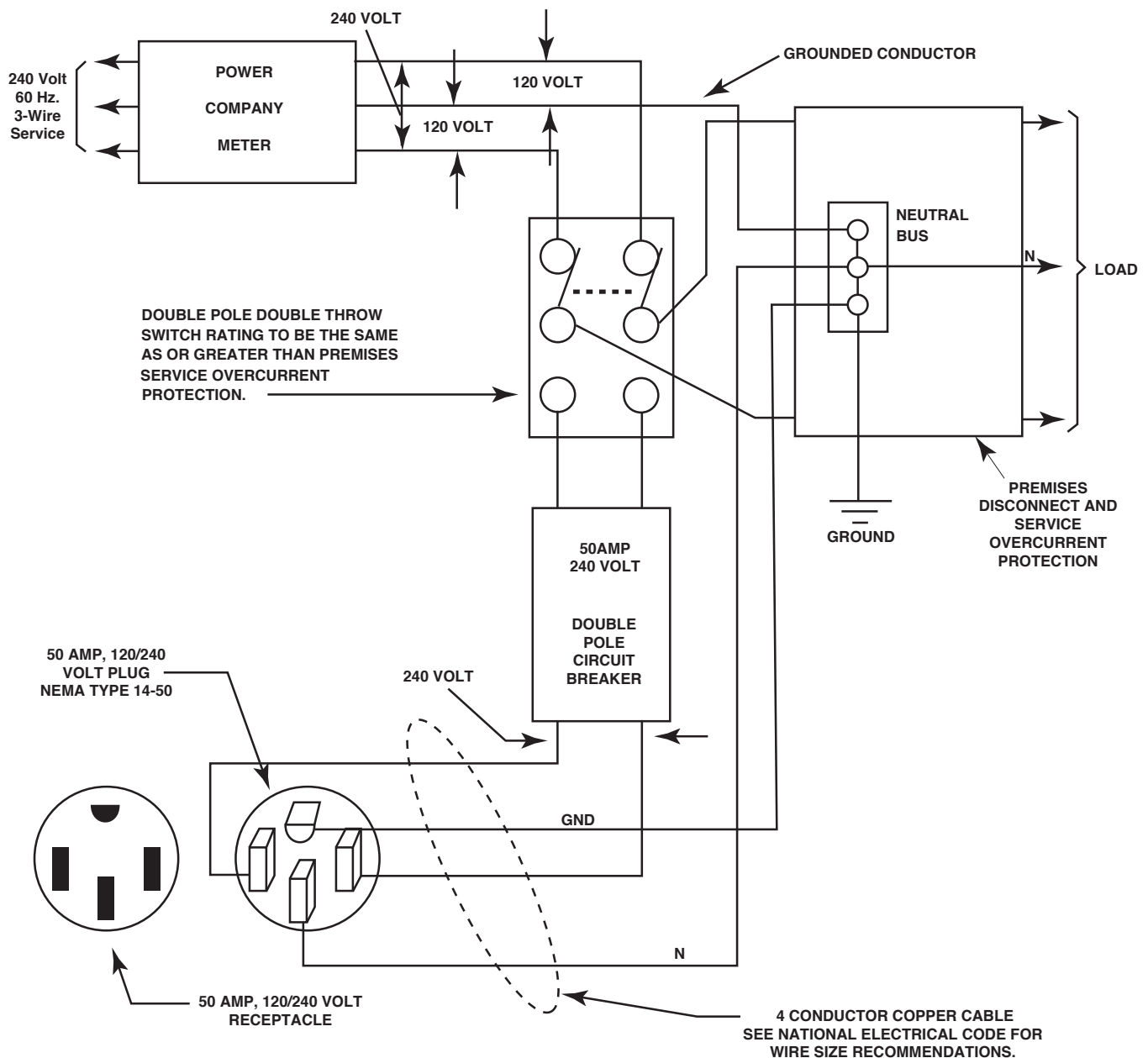

Operation - VANTAGE® 500 Deutz F4L2011 (Codes 11180,11415)

Operating InstructionsB2.2

Safety InstructionsB2.2

General DescriptionB2.2

 Recommended ApplicationsB2.3

 Design Features and AdvantagesB2.3

Controls and SettingsB2.4

 Engine ControlsB2.4

 Welding ControlsB2.6

 Auxiliary Power ControlsB2.6

Engine OperationB2.7

 Starting the EngineB2.7

 Stopping the EngineB2.7

 Break-In PeriodB2.7

 Typical Fuel ConsumptionB2.7

Welder OperationB2.8

 Stick WeldingB2.8

 Constant Current (CC) WeldingB2.8

 Pipe WeldingB2.8

 TIG WeldingB2.8

 Wire Feed (Constant Voltage) WeldingB2.10

Auxiliary Power OperationB2.10

 Arc GougingB2.10

 ParallelingB2.10

Simultaneous Welding and Auxiliary Power LoadsB2.11

Extension Cord RecommendationsB2.11

Return to Master TOC

Return to Master TOC

Return to Master TOC

Return to Master TOC

OPERATING INSTRUCTIONS

Read and understand this entire section before operating your Vantage 500.

SAFETY INSTRUCTIONS

WARNING

Do not attempt to use this equipment until you have thoroughly read all operating and maintenance manuals supplied with your machine. They include important safety precautions: detailed engine starting, operating, and maintenance instructions and parts lists.



ELECTRIC SHOCK can kill.

- Do not touch electrically live parts or electrodes with your skin or wet clothing.
- Insulate yourself from the work and ground.
- Always wear dry insulating gloves.

FUMES AND GASES CAN BE DANGEROUS.



- Keep your head out of fumes.
- Use ventilation or exhaust to remove fumes from breathing zone.

WELDING SPARKS CAN CAUSE FIRE OR EXPLOSION.



- Keep flammable material away.
- Do not weld on containers that have held combustibles.

ARC RAYS CAN BURN.



- Wear eye, ear, and body protection.



ENGINE EXHAUST can kill.

- Use in open, well ventilated areas or vent exhaust outside
- Do not stack anything near the engine.



MOVING PARTS can injure.

- Do not operate with doors open or guards off.
- Stop engine before servicing.
- Keep away from moving parts

Only qualified personnel should operate this equipment.

ADDITIONAL SAFETY PRECAUTIONS

Always operate the welder with the hinged door closed and the side panels in place, as these provide maximum protection from moving parts and insure proper cooling air flow.

GENERAL DESCRIPTION

The Vantage 500 is a diesel engine-driven welding power source. The machine uses a brush type alternating current generator for DC multi-purpose welding and for 120/240VAC single phase and 240VAC three phase auxiliary standby power. The welding control system uses state of the art **Chopper Technology**.

The generator has a single sealed bearing for maintenance free service. The rotor is a copper wound design with two slip rings and brushes. The stator is wound entirely with heavy gauge copper wire and insulated with NEMA class F insulation material. The stator is then impregnated with three layers of high quality varnish. After the stator is assembled using tie bars, the entire assembly is covered with an environmentally protective coating. These measures insure trouble-free operation in the harshest environments.

The fuel tank is made from high density polyethylene and holds 25 gallons (94.6 liters) of diesel fuel. This will provide enough fuel to run for more than 12 hours at full load.

The Deutz F3L-912 engine is equipped with a standard, heavy duty, combination fuel filter/water separator element.

VANTAGE® 500



RECOMMENDED APPLICATIONS

WELDER

The Vantage 500 provides excellent constant current DC welding output for stick (SMAW) and TIG welding. The Vantage 500 also provides excellent constant voltage DC welding output for MIG (GMAW) and Innershield (FCAW) welding.

GENERATOR

The Vantage 500 provides smooth 120/240 VAC output for auxiliary power and emergency standby power.

DESIGN FEATURES AND ADVANTAGES

K1639-2 VANTAGE 500 DELUXE MODEL FEATURES

FOR WELDING

- Excellent DC multi-purpose welding for stick, MIG, TIG, cored wire and arc gouging applications.
- 30 to 500 amps output in five slope-controlled ranges for out-of position and pipe electrodes, one constant current output range for general purpose welding, one constant voltage range for MIG wire and cored wire welding and one 20-250 amp range for "Touch Start" TIG welding.
- 100% duty cycle at 500 amps output and 50% duty cycle at 575 amps output.
- Dual 3-digit output meters are provided (optional on K1639-1) for presetting the weld amperage or voltage and displaying the actual amperage and voltage during welding. The meters use superbrite L.E.D.'s for improved readability in full sunlight.

LOOK-BACK FEATURE: After welding has stopped, both displays will remain on for 7 seconds with the last current and voltage value displayed. During this time, the left-most decimal point in each display will be FLASHING.

- Standard remote control capability with 14-pin and 6-pin connectors for easy connection of Lincoln remote control accessories.
- An internal "Solid State" contactor allows for the selection of "hot" or "cold" output terminals with a toggle switch on the control panel.
- "Arc Control" potentiometer in Wire and Stick modes for precise adjustment of arc characteristics.
- Advanced circuitry to prevent pop-outs in the five slope modes.

FOR AUXILIARY POWER

- 12,000 watts of 120/240 VAC, 60Hz auxiliary power.
- Power for tools, 120/240 VAC lights, electric pumps and for standby emergency power.
- Drive a 5 HP motor (provided it is started under no load).
- Two 20 amp 120 VAC duplex receptacles for up to 40 amps of 120 VAC power.
- One 50 amp, 120/240 VAC dual voltage receptacle for up to 50 amps of 240 VAC, and up to 50 amps per side to separate branch circuits (not in parallel) of 120 VAC single-phase auxiliary power. Allows easy connection to premises wiring.
- Weld and AC auxiliary power at the same time (within machine total capacity).

OTHER FEATURES

- Deutz 3-cylinder, air/oil cooled diesel engine. Designed for long life, easy maintenance, and excellent fuel economy.
- Engine protection system shuts the engine down for low oil pressure, high oil temperature, or a broken fan/engine alternator belt.
- Gauges for oil pressure, oil temperature, engine alternator output, and fuel level.
- Indicator lights for Engine Protection, and Battery (engine alternator low output/broken belt).
- Engine hour meter standard on all models.
- Extended range 25 gallon (94.6 l) fuel tank.
- Automatic idler reduces engine speed when not welding or drawing auxiliary power. This feature reduces fuel consumption and extends engine life.
- Compact size fits crosswise in full size pickup truck.
- Single-side engine service.
- Copper alternator windings and high temperature insulation for dependability and long life.
- New paint system on case and base for outstanding corrosion protection.

VANTAGE® 500



CONTROLS AND SETTINGS

All welder and engine controls are located on the case front panel. Refer to Figure B.1 and the explanations that follow.

Figure B2.1 Case Front Panel Controls

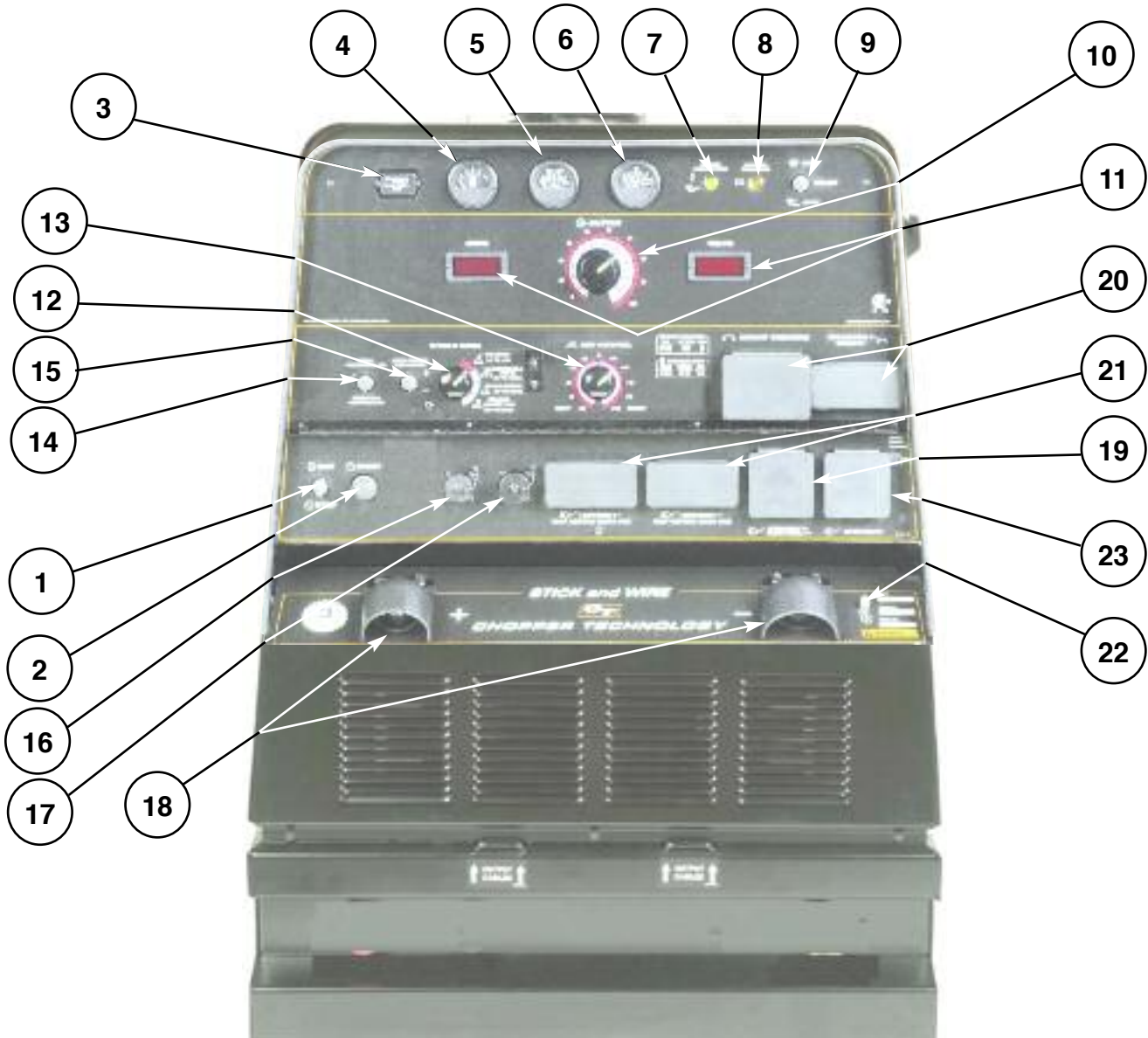

ENGINE CONTROLS (Items 1 through 9)

1. RUN STOP SWITCH

Toggling the switch to the RUN position energizes the fuel solenoid for approximately 30 seconds. The engine must be started within that time or the fuel solenoid will deenergize, and the switch must be toggled to reset the timer.

2. START PUSHBUTTON

Energizes the starter motor to crank the engine. With the engine "Run / Stop" switch in the "Run" position, push and hold the Start button to crank the engine; release as the engine starts. Do not press while engine is running since this can cause damage to the ring gear and/or starter motor

3. HOUR METER

The hour meter displays the total time that the engine has been running. This meter is a useful indicator for scheduling preventive maintenance.

4. FUEL LEVEL GAUGE

Displays the level of diesel fuel in the fuel tank.

The operator must watch the fuel level closely to prevent running out of fuel and possibly having to bleed the system.

5. ENGINE TEMPERATURE GAUGE

The gauge displays the engine coolant temperature.

VANTAGE® 500

LINCOLN
ELECTRIC

6. OIL PRESSURE GAUGE

The gauge displays the engine oil pressure when the engine is running.

7. ENGINE PROTECTION

The yellow engine protection light remains off with proper oil pressure and under normal operating temperatures. If the light turns on, the engine protection system will stop the engine. Check for proper oil and coolant levels and add oil and/or coolant if necessary. Check for loose or disconnected leads at the oil pressure sender located on the engine. The light will remain on when the engine has been shut down due to low oil pressure or over-temperature condition.



NOTE: This engine is equipped with an electronic governor system. The engine speed ramps up during a warm up period. The complete cycle takes approximately 3 minutes. This allows the engine cylinder temperature to build up slowly before going to full speed. This feature is bypassed if the engine is already warm. The Engine may produce "White Smoke" for a few minutes at low temperatures. Do not apply a load to the machine during the warm up period.

8. BATTERY CHARGING LIGHT

The yellow engine alternator light is off when battery charging system is functioning normally. If light turns on the alternator or the voltage regulator may not be operating correctly. The light will remain on when the engine is stopped and the run/stop switch is in the run position.

9. IDLER SWITCH

Has two positions as follows:

- A) In the "High" position,  the engine runs at the high idle speed controlled by the governor.
- B) In the "Auto"  /  position, the idler operates as follows:
- When switched from "High" to "Auto" or after starting the engine, the engine will operate at full speed for approximately 12 seconds and then go to low idle speed.
 - When the electrode touches the work or power is drawn for lights or tools (approximately 100 Watts minimum) the engine accelerates and operates at full speed.
 - When welding ceases and the AC power load is turned off, a fixed time delay of approximately 12 seconds starts.

d. If the welding or AC power load is not restarted before the end of the time delay, the idler reduces the engine speed to low idle speed.

e. The engine will automatically return to high idle speed when the welding load or A.C. power load is reapplied.

Idler Operational exceptions

When the WELDING TERMINALS switch is in the "Remotely Controlled" position the idler will operate as follows:

- When the triggering device (Amptrol, Arc Start Switch, etc.) is pressed the engine will accelerate and operate at full speed provided a welding load is applied within approximately 12 seconds.
- If the triggering device remains pressed but no welding load is applied within approximately 12 seconds the engine may return to low idle speed.
- If the triggering device is released or welding ceases the engine will return to low idle speed after approximately 12 seconds.

WELDING CONTROLS (Items 10 through 19)

10. OUTPUT CONTROL: The OUTPUT dial is used to preset the output voltage or current as displayed on the digital meters for the four welding modes. When in the CC-STICK, DOWNHILL PIPE or CV-WIRE modes and when a remote control is connected to the 6-Pin or 14-Pin Connector, the auto-sensing circuit automatically switches the OUTPUT CONTROL from control at the welder to the remote control. In the CV-WIRE mode, when the wire feeder control cable is connected to the 14-Pin Connector, the auto-sensing circuit automatically makes OUTPUT CONTROL inactive and the wire feeder voltage control active.

When in the TOUCH START TIG mode and when a Amptrol is connected to the 6-Pin Connector, the OUTPUT dial is used to set the maximum current range of the CURRENT CONTROL of the Amptrol.

11. DIGITAL OUTPUT METERS:

The digital meters allow the output voltage (CV-WIRE mode) or current (CC-STICK, DOWNHILL PIPE and TIG modes) to be set prior to welding using the OUTPUT control knob. During welding, the meters display the actual output voltage (VOLTS) and current (AMPS). A memory feature holds the display of both meters on the seven seconds after welding is stopped. This allows the operator to read the actual current and voltage just prior to when welding was ceased. While the display is being held the left-most decimal point in each display will be flashing. The accuracy of the meters is $\pm 3\%$.

12. WELD MODE SELECTOR SWITCH:

(Provides four selectable welding modes)

CV-WIRE
DOWNHILL PIPE
CC-STICK
TOUCH START TIG

13. ARC CONTROL:

The ARC CONTROL WIRE/STICK knob is active in the WIRE and STICK modes, and has different functions in these modes. This control is not active in the TIG mode.

CC-STICK mode: In this mode, the ARC CONTROL knob sets the short circuit current (arc-force) during stick welding. Increasing the number from -10(Soft) to +10(Crisp) increases the short circuit current and prevents sticking of the electrode to the plate while welding. This can also increase spatter. It is recommended that the ARC CONTROL be set to the minimum number without electrode sticking. Start with a setting at 0.

DOWNHILL PIPE mode: In this mode, the ARC CONTROL knob sets the short circuit current (arc-force) during stick welding to adjust for a soft or a more forceful digging arc (Crisp). Increasing the number from -10(Soft) to +10(Crisp) increases the short circuit current which results in a more forceful digging arc. Typically a forceful digging arc is preferred for root and hot passes. A softer arc is preferred for fill and cap passes where weld puddle control and deposition ("stacking" of iron) are key to fast travel speeds. It is recommended that the ARC CONTROL be set initially at 0.

CV-WIRE mode: In this mode, turning the ARC CONTROL knob from -10(soft) to +10(crisp) changes the arc from soft and washed-in to crisp and narrow. It acts as an inductance/pinch control. The proper setting depends on the procedure and operator preference. Start with a setting of 0.

14. WELDING TERMINALS SWITCH

In the WELD TERMINALS ON position, the output is electrically hot all the time. In the REMOTELY CONTROLLED position, the output is controlled by a wire feeder or amptrol device, and is electrically off until a remote switch is depressed.

15. WIRE FEEDER VOLTMETER SWITCH:

Matches the polarity of the wire feeder voltmeter to the polarity of the electrode.

16. 6 - PIN CONNECTOR

For attaching optional remote control equipment. Includes auto-sensing remote control circuit.

17. 14 - PIN CONNECTOR

For attaching wire feeder control cables. Includes contactor closure circuit, auto-sensing remote control circuit, and 120VAC and 42VAC power.

NOTE: When a wire feeder with a built in welding voltage control is connected to the 14-pin connector, do not connect anything to the 6-pin connector.

18. WELD OUTPUT TERMINALS + AND -

These 1/2" - 13 studs with flange nuts provide welding connection points for the electrode and work cables. For positive polarity welding the electrode cable connects to the "+" terminal and the work cable connects to this "-" terminal. For negative polarity welding the work cable connects to the "+" terminal and the electrode cable connects to this "-" terminal.

AUXILIARY POWER CONTROLS

(Items 19-23)

19. 120/240 VAC SINGLE PHASE RECEPTACLE

This is a 120/240VAC (14-50R) receptacle that provides 240VAC or can be split for 120VAC single phase auxiliary power. This receptacle has a 50 amp rating. Refer to the AUXILIARY POWER RECEPTACLES section in the installation chapter for further information about this receptacle. Also refer to the AUXILIARY POWER OPERATION section later in this chapter.

20. CIRCUIT BREAKERS

These circuit breakers provide separate overload current protection for each 120V circuit at the 240V single phase receptacle, each 120V single phase receptacle, the 240V three phase receptacle, the 120VAC in the 14-Pin connector, the 42VAC in the 14-Pin connector and battery circuit overload protection.

21. 120VAC SINGLE PHASE RECEPTACLES

These two 120VAC (5-20R) receptacles with GFCI protection provide 120VAC single phase for auxiliary power. Each receptacle has a 20 amp total rating. They are designed to protect the user from the hazards of ground faults. When the GFCI has tripped there will be no voltage available from the receptacle. Refer to the AUXILIARY POWER RECEPTACLES section in the installation chapter for further information about these receptacles. Also refer to the AUXILIARY POWER OPERATION section later in this chapter.

22. GROUND STUD

Provides a connection point for connecting the machine case to earth ground. Refer to "MACHINE GROUNDING" in the Installation chapter for proper machine grounding information.

23. 240VAC THREE PHASE RECEPTACLE

This is a 240VAC (15-50R) receptacle that provides 240VAC three phase auxiliary power. This receptacle has a 50 amp rating. **This receptacle is not present on the models covered by this manual.**

ENGINE OPERATION

STARTING THE ENGINE

1. Open the engine compartment door and check that the fuel shutoff valve is in the open position (lever to be in line with the hose).
2. Check for proper oil level and coolant level. Close engine compartment door.
3. Remove all plugs connected to the AC power receptacles.
4. Set IDLER switch to "AUTO".
5. Set the RUN/STOP switch to "RUN". Observe that the engine protection and battery charging lights are on. The engine protection light may turn off after 5 seconds or remain on until the engine is started.

6. Within 30 seconds, press and hold the engine START button until the engine starts. If the engine does not start within 30 seconds the RUN/STOP switch must be returned to the STOP position, then return to step 5.
7. Release the engine START button when the engine starts.
8. Check that the engine protection and battery charging lights are off. Investigate any indicated problem.

NOTE: The engine will go through a 3 minute warm-up cycle if cold. If the engine coolant is still warm from recent operation, the engine will go immediately to high idle and then to low idle if the idle switch is in the "AUTO" position.

COLD WEATHER STARTING

With a fully charged battery and the proper weight oil, the engine should start satisfactorily even down to about 0°F(-18°C). If the engine must be frequently started below 10°(-12°C), it may be desirable to install the optional ether start kit (K887-1). Installation and operating instructions are included in the kits.

STOPPING THE ENGINE

1. Switch the RUN/STOP switch to "STOP". This turns off the voltage supplied to the shutdown solenoid. A backup shutdown can be accomplished by shutting off the fuel valve located on the fuel line.

BREAK-IN PERIOD

The engine used to supply power for your welder is a heavy duty, industrial engine. It is designed and built for rugged use. It is very normal for any engine to use small quantities of oil until the break-in is accomplished. Check the oil level twice a day during the break-in period. In general this takes 50 to 100 hours of operation.

IMPORTANT

IN ORDER TO ACCOMPLISH THIS BREAK-IN, THE UNIT SHOULD BE SUBJECTED TO HEAVY LOADS, WITHIN THE RATING OF THE MACHINE. AVOID LONG IDLE RUNNING PERIODS.

TYPICAL FUEL CONSUMPTION

Refer to **Table B2.1** for typical fuel consumption of the VANTAGE 500 Engine for various operating scenarios.

**Table B2.1 – DEUTZ F4L2011
ENGINE FUEL CONSUMPTION**

	Deutz F4L1022 48 HP @1800 rpm	Running Time 25 Gal.(94.6L) (Hours)
Low Idle No Load 1475 rpm	.47 gallons/ hour (1.77 liters/hour)	53
High Idle No Load 1900 rpm	.66 gallons/hour (2.50 liters/hour)	40
DC-CC Welding 500A @40V	1.94 gallons/hour (7.34 liters/hour)	12.6
Auxiliary Power 12,000 VA	1.31 gallons/hour (4.96 liters/hour)	20.0
Auxiliary Power 20,000VA	1.76 Gal./hour (6.66L/hour)	14.2

WELDER OPERATION

DUTY CYCLE

Duty Cycle is the ratio of the uninterrupted on-load duration to 10 minutes. The total time period of one complete on-load and no-load cycle is 10 minutes. For example, in the case of a 60% duty cycle, load is applied continuously for 6 minutes followed by a no-load period of 4 minutes.

STICK WELDING MODE

The Vantage can be used with a broad range of DC stick electrodes.

The MODE switch provides two stick welding settings as follows:

CC-STICK MODE

The CC-STICK position of the MODE switch is designed for horizontal, vertical-up and overhead welding with all types of electrodes, especially low hydrogen. The OUTPUT CONTROL knob adjusts the full output range for stick welding.

The ARC CONTROL knob sets the short circuit (arc-force) current during stick welding. Increasing the number from -10 (Soft) to +10 (Crisp) increases the short circuit current and prevents sticking of the electrode to the plate while welding. This can also increase spatter. It is recommended that the ARC CONTROL be set to the minimum number without electrode sticking. Start with the knob set at 0.

DOWNHILL PIPE MODE

This slope controlled setting is intended for “out-of-position” and “down hill” pipe welding where the operator would like to control the current level by changing the arc length. The OUTPUT CONTROL knob adjusts the full output range for pipe welding.

The ARC CONTROL knob sets the short circuit current (arc-force) during stick welding to adjust for a soft or a more forceful digging arc (Crisp). Increasing the number from -10 (Soft) to +10 (Crisp) increases the short circuit current which results in a more forceful digging arc. Typically a forceful digging arc is preferred for root and hot passes. A softer arc is preferred for fill and cap passes where weld puddle control and deposition (“stacking” of iron) are key to fast travel speeds. It is recommended that the ARC CONTROL be set initially at 0.

TOUCH START TIG MODE

The Vantage can be used in a wide variety of DC TIG welding applications.

The TOUCH START TIG setting of the MODE switch is for DC TIG (Tungsten Inert Gas) welding. To initiate a weld, the OUTPUT CONTROL knob is first set to the desired current and the tungsten is touched to the work. During the time the tungsten is touching the work there is very little voltage or current and, in general, avoids tungsten contamination. Then, the tungsten is gently lifted off the work in a rocking motion, which establishes the arc.

To stop the arc, simply lift the TIG torch away from the work piece. When the arc voltage reaches approximately 30 volts, the arc will go out and the machine will automatically reset to the touch start current level. The tungsten may then be retouched to the work piece to restrike the arc. The arc may also be started and stopped with an Amptrol or Arc Start Switch.

The ARC CONTROL is not active in the TIG mode.

In general the ‘Touch Start’ feature avoids tungsten contamination without the use of a Hi-frequency unit. If the use of a high frequency generator is desired, the K930-2 TIG Module can be used with the Vantage. The settings are for reference.

The Vantage is equipped with the required R.F. bypass circuitry for the connection of high frequency generating equipment.

The Vantage and any high frequency generating equipment must be properly grounded. See the K930-2 TIG Module operating manuals for complete instructions on installation, operation, and maintenance.

When using the TIG Module, the OUTPUT control on the Vantage is used to set the maximum range of the CURRENT CONTROL on the TIG Module or an Amptrol if connected to the TIG Module.

VANTAGE® 500



TABLE B2.2 – TYPICAL CURRENT RANGES¹ FOR TUNGSTEN ELECTRODES²

Tungsten Electrode Diameter in. (mm)	DCEN (-)	DCEP (+)	Approximate Argon Gas Flow Rate C.F.H. (l/min.)		TIG TORCH Nozzle Size ^{4,5}
	1%, 2% Thoriated Tungsten	1%, 2% Thoriated Tungsten	Aluminum	Stainless Steel	
0.010 (.25)	2-15	³	3-8 (2-4)	3-8 (2-4)	#4, #5, #6
0.020 (.50)	5-20	³	5-10 (3-5)	5-10 (3-5)	
0.40 (1.0)	15-80	³	5-10 (3-5)	5-10 (3-5)	
1/16 (1.6)	70-150	10-20	5-10 (3-5)	9-13 (4-6)	#5, #6
3/32 (2.4)	150-250	15-30	13-17 (6-8)	11-15 (5-7)	#6, #7, #8
1/8 (3.2)	250-400	25-40	15-23 (7-11)	11-15 (5-7)	
5/32 (4.0)	400-500	40-55	21-25 (10-12)	13-17 (6-8)	#8, #10
3/16 (4.8)	500-750	55-80	23-27 (11-13)	18-22 (8-10)	
1/4 (6.4)	750-1000	80-125	28-32 (13-15)	23-27 (11-13)	

¹When used with argon gas. The current ranges shown must be reduced when using argon/helium or pure helium shielding gases.

²Tungsten electrodes are classified as follows by the American Welding Society (AWS):

Pure	EWP
1% Thoriated	EWTh-1
2% Thoriated	EWTh-2

Though not yet recognized by the AWS, Ceriated Tungsten is now widely accepted as a substitute for 2% Thoriated Tungsten in AC and DC applications.

³DCEP is not commonly used in these sizes.

⁴TIG torch nozzle “sizes” are in multiples of 1/16ths of an inch:

# 4 = 1/4 in. (6 mm)	# 7 = 7/16 in. (11 mm)
# 5 = 5/16 in. (8 mm)	# 8 = 1/2 in. (12.5 mm)
# 6 = 3/8 in. (10 mm)	#10 = 5/8 in. (16 mm)

⁵TIG torch nozzles are typically made from alumina ceramic. Special applications may require lava nozzles, which are less prone to breakage, but cannot withstand high temperatures and high duty cycles.

VANTAGE 500 SETTINGS WHEN USING THE K799 HI-FREQ UNIT

- Set the WELD MODE switch to the 20-250 setting (TIG).
- Set the IDLER switch to the HIGH position.
- Set the WELDING TERMINALS switch to the WELD TERMINALS ON position. This will close the solid state contactor and provide an always “hot” electrode.

NOTE: This is necessary because the K799 circuitry with respect to the #2 and #4 leads does not provide the proper signal to open and close the solid state contactor in the Vantage 500.

VANTAGE 500 SETTINGS WHEN USING A K930-[] TIG MODULE

- Set the WELD MODE switch to the 20-250 setting (TIG).
- Set the IDLER switch to the AUTO position.
- Set the WELDING TERMINALS switch to the REMOTELY CONTROLLED position. This will keep the solid state contactor open and provide a “cold” electrode until the triggering device (Amptrol or Arc Start Switch) is pressed.

VANTAGE® 500



WIRE FEED (CONSTANT VOLTAGE) WELDING

Connect a wire feeder to the Vantage 500 and set welder controls according to the instructions listed earlier in this section. See the operator's manual for the wire feeder or the "*Diagrams*" section of this manual for connecting instructions of various Lincoln wire feeders.

The Vantage 500 in the CV-WIRE position can be used with a broad range of flux cored wire (Innershield and Outershield) electrodes and solid wires for MIG welding (GMAW). Welding can be finely tuned using the ARC CONTROL.

Some recommended Innershield electrodes are: NR-311, NS-3M, NR-207, NR-203 Ni 1%, NR-204-H.

Recommended Outershield electrodes are: 0S-70, 0S-71M.

Some recommended solid wires for MIG welding are: .035 (0.9 mm), .045 (1.1 mm) and .052 (1.3 mm), L-50 and L-56, .035 (0.9 mm) and .045 (1.1 mm) Blue Max MIG 308 LS.

For any electrodes, including the above recommendations, the procedures should be kept within the rating of the machine. For additional electrode information, see Lincoln publications N-675, GS-100 and GS-210.

AUXILIARY POWER OPERATION

Start the engine and set the IDLER control switch to the desired operating mode. Full power is available regardless of the welding control settings, if no welding current is being drawn.

The auxiliary power of the Vantage consists of two 20 Amp-120VAC (5-20R) duplex receptacles and one 50 Amp-120/240 VAC (14-50R) receptacle. The 120/240VAC receptacle can be split for single phase 120 VAC operation.

The auxiliary power capacity is 12,000 watts of 60 Hz, single phase power. The auxiliary power capacity rating in watts is equivalent to volt-amperes at unity power factor. The maximum permissible current of the 240 VAC output is 50 A. The 240 VAC output can be split to provide two separate 120 VAC outputs with a maximum permissible current of 50 A per output to two separate 120 VAC branch circuits. Output voltage is within $\pm 10\%$ at all loads up to rated capacity.

NOTE: The 120/240V receptacle has two 120V outputs of different phases and cannot be paralleled.

The auxiliary power receptacles should only be used with three-wire grounded type plugs or approved double insulated tools with two wire plugs.

The current rating of any plug used with the system must be at least equal to the current capacity of the associated receptacle.

SIMULTANEOUS WELDING AND AUXILIARY POWER LOADS

It must be noted that the above auxiliary power ratings are with no welding load. Simultaneous welding and power loads are specified in **Table B2.3 or B2.4**. The permissible currents shown assume that current is being drawn from either the 120 VAC or 240 VAC supply (not both at the same time).

ARC GOUGING

For optimal performance when arc gouging, set the Vantage 500 WELD MODE switch to the CC - STICK position, and the ARC CONTROL to 10.

Set the OUTPUT knob to adjust output current to the desired level for the gouging electrode being used according to the ratings in the following table:

Electrode Diameter	Current Range (DC, electrode positive)
1/8"	30-60 Amps
5/32"	90-150 Amps
3/16"	150-200 Amps
1/4"	200-400 Amps
5/16"	250-400 Amps
3/8"	350-575 Amps*

* Maximum current setting is limited to the Vantage 500 maximum of 575 Amps.

PARALLELING

When paralleling machines in order to combine their outputs, all units must be operated in the CC - STICK mode only. To achieve this, turn the WELD MODE switch to the CC - STICK position. Operation in other modes may produce erratic outputs and large output imbalances between the units.

TABLE B2.3 Vantage 500 Duetz Simultaneous Welding and Power Loads

Welding Output at NEMA Voltage ($V = .04I + 20$)	Permissible Power Watts (Unity Power Factor)	Permissible Auxiliary Current in Amperes	
		@ 120VAC * +/- 10%	@ 240 VAC +/- 10%
0-250A/30V	12,000	100**	50
350A/34V	8,100	68**	34
400A/36V	5,600	46	23
450A/38V	2,900	24	12
500A/40V	0	0	0

* Each duplex receptacle is limited to 20 amps.

** Not to exceed 50A per 120 VAC branch circuit when splitting the 240 VAC output.

EXTENSION CORD RECOMMENDATIONS

An extension cord can be used with the auxiliary power outputs as long as it is of ample size. Table B.5 lists permissible extension cord lengths based on conductor size and auxiliary power output.

TABLE B2.4 – VANTAGE 500 EXTENSION CORD LENGTH RECOMMENDATIONS

Current (Amps)	Voltage (Volts)	Load (Watts)	Maximum Allowable Cord Length in ft. (m) for Conductor Size											
			14 AWG		12 AWG		10 AWG		8 AWG		6 AWG		4 AWG	
15	120	1800	30	(9)	40	(12)	75	(23)	125	(38)	175	(53)	300	(91)
15	240	3600	60	(18)	75	(23)	150	(46)	225	(69)	350	(107)	600	(183)
20	120	2400			30	(9)	50	(15)	88	(27)	138	(42)	225	(69)
20	240	48010			60	(18)	100	(30)	175	(53)	275	(84)	450	(137)
25	240	6000					90	(27)	150	(46)	225	(69)	250	(76)
30	240	7200					75	(23)	120	(37)	175	(53)	300	(91)
38	240	9000							100	(30)	150	(46)	250	(76)
50	240	12000									125	(38)	200	(61)

Conductor size is based on maximum 2.0% voltage drop.

Return to Section TOC

Return to Section TOC

Return to Section TOC

Return to Section TOC

Return to Master TOC

Return to Master TOC

Return to Master TOC

Return to Master TOC

VANTAGE® 500



Accessories - VANTAGE® 500 Deutz F4L2011 (Codes 11180, 11415)

Options/AccessoriesC2.2

 Optional Field Installed AccessoriesC2.2

 TIG Welding OptionsC2.3

 Plasma Cutting OptionC2.2

 High Frequency Generators for TIG ApplicationsC2.3

 Wire Feeder OptionsC2.3

Return to Master TOC

Return to Master TOC

Return to Master TOC

Return to Master TOC

OPTIONAL FIELD INSTALLED ACCESSORIES

K802N POWER PLUG KIT - Provides four 120V plugs rated at **20 amps** each and one dual voltage, full KVA plug rated at 120/240V, 50 amps. 120V plug may not be compatible with NEMA common household receptacles.

K802R POWER PLUG KIT - Provides four 120V plugs rated **15 amps** each and one dual voltage, full KVA plug rated at 120/240V, 50 amps, 120V plug is compatible with NEMA common household receptacles.

K857 25 ft. (7.5 m) or K857-1 100 ft. (30.4 m) REMOTE CONTROL - Portable control provides same dial range as the output control on the welder from a location up to the specified length from the welder. Has convenient plug for easy connection to the welder. The VANTAGE 500 CUMMINS is equipped with a 6-pin connector for connecting the remote control.

K704 ACCESSORY SET - Includes 35 feet (10 m) of electrode cable and 30 feet (9 m) of work cable, head-shield, Filter plate, work clamp and electrode holder. Cable is rated at 500 amps, 60% duty cycle.

K2641-2 FOUR WHEELED STEERABLE YARD TRAILER

For in plant and yard towing. Comes standard with a Duo-Hitch™, a 2" Ball and Lunette Eye combination hitch.

K2636-1 TRAILER - Two-wheeled trailer with optional fender and light package. For highway use, consult applicable federal, state, and local laws regarding possible additional requirements. Comes standard with a Duo-Hitch™, a 2" Ball and Lunette Eye combination hitch, a fender & a light package. **Order:**

K2636-1 Trailer

K958-1 Ball Hitch

K958-2 Lunette Eye Hitch

K2639-1 Fender & Light Kit

K2640-1 Cable Rack

K887-1 ETHER START KIT - Provides maximum cold weather starting assistance for frequent starting below 10°(-12°C). Required Ether tank is not provided with kit.

K899-1 SPARK ARRESTOR KIT - Easily mounts to standard muffler.

K1816-1 Full KVA Adapter Kit - Plugs into the 120/240V NEMA 14-50R receptacle on the case front (which accepts 4-prong plugs) and converts it to a NEMA 6-50R receptacle (which accepts 3-prong plugs) for connection to Lincoln Equipment with a NEMA 6-50P plug,

T12153-9 Full-KVA Power Plug-One dual voltage plug rated at 120/240V, 50 amps, single phase.

K2356-1 Control Panel Cover Kit-Clear plexiglass cover to protect control panel from dirt and debris, and to visually monitor machine operation. Lockable to deter vandalism.

K2340-1 Lockable Fuel Cap / Flash Arrester Kit-For use in locations where flash arrester safety is required. Lockable fuel cap prevents tampering with fuel. Green cap color provides a visual reminder to use diesel when refueling.

PLASMA CUTTING

K1581-1 Pro-cut 80 - Cuts mild steel using the 3-phase AC generator power from the engine driven welder.

NOTE: Other Linclon plasma cutters, both single phase and 3 phase can be used as long as the rating of the receptacle is not exceeded

WARNING

Pipe Thawing with an arc welder can cause fire, explosion, damage to electric wiring or to the arc welder if done improperly. The use of an arc welder for pipe thawing is not approved by the CSA, nor is it recommended or supported by Lincoln Electric.

TIG OPTIONS

K1783-9 PTA-26V TIG Torch

Air Cooled 200 amp torch (2 piece) equipped with valve for gas flow control. 25 ft. (7.6m) length.

KP509 Magnum Parts Kit for PTA-26V TIG Torch

Magnum Parts Kit provides all the torch accessories you need to start welding. Parts kit provides collets, collet bodies, a black cap, alumina nozzles and tungstens in a variety of sizes, all packaged in an easy to carry reclosable sack.

K870 Foot Amptrol®-Varies current while welding for making critical TIG welds and crater filling. Depress pedal to increase current. Depressing pedal fully achieves maximum set current. Fully raising the pedal finishes the weld and starts the after flow cycle on systems so equipped. Includes 25 ft. (7.6m) control cable.

K963-3 Hand Amptrol®-Varies current for making critical TIG welds. Fastens to the torch for convenient thumb control. Comes with a 25 ft. (7.6m) cable. (One size fits all Pro-Torch TIG Torches.)

K2347-1 Precision TIG 185 Ready-Pak

For AC TIG Welding with square wave performance use the AC generator of the Engine-Driven Welder to supply the power. Easy setup. Includes torch, foot amptrol, gas regulator and hose. Requires the K1816-1 Full KVA adapter kit.

K2350-1 Invertec® V205-T AC/DC One-Pak™ Package

For AC TIG welding with square wave performance, use the AC generator of the engine-driven welder to supply the power. Easy setup. Includes torch, parts kit, regulator and hose kit, Twist-Mate™ torch adapter, work cable with Twist-Mate end and foot Amptrol®.

HIGH FREQUENCY GENERATORS FOR TIG APPLICATIONS

The K799 Hi-Freq Unit and the K930- [] TIG Modules are suitable for use with the Vantage 500. The Vantage 500 is equipped with the required RF bypass circuitry for the connection of high frequency generating equipment. The high frequency bypass network supplied with the K799 Hi-Freq Unit does NOT need to be installed into the Vantage 500.

The Vantage 500 and any high frequency-generating equipment must be properly grounded. See the K799 Hi-Freq Unit and the K930-All TIG Module operating manuals for complete instructions on installation, operation, and maintenance.

WIRE FEEDER OPTIONS

K449 LN-25 Wire Feeder

Portable CC/CV unit for flux-cored and MIG welding. Includes Gas Solenoid & Internal Contactor.

K126-2 Magnum® 350 Innershield Gun (for LN-25)

For self-shielded wire with 15 ft. (4.5m) cable. For .062-3/32" (1.6-2.4mm) wire.

KP653-3/32 Drive Roll and Guide Tube Kit (for LN-25)
For .068-3/32" (1.8-2.4mm) cored or solid steel wire.

K1802-1 Magnum® 300 MIG Gun

For .035-.045 (0.9-1.2mm) gas shielded wire. Includes 15 ft. gun and cable assembly and connector kit.

KP653-035S Drive Roll and Guide Tube Kit (for LN-25)

For .035-.040" (0.9-1.0mm) solid steel wire.

K2613-1 LN-25 PRO PORTABLE WIRE FEEDER-The MAXTRAC® wire drive enhances performance, while the replacement case, and many other upgrade options that can be installed in less than five minutes aid in the serviceability.

KP1697-5/64 Drive Roll Kit- Includes: 2 polished U groove drive rolls, outer wire guide and inner wire guide for solid core wire. (Used on LN-25 Pro)

KP1697-068 Drive Roll Kit- Includes: 2 polished U groove drive rolls, outer wire guide and inner wire guide for solid core wire. (Used on LN-25 Pro)

KP1696-1 Drive Roll Kit- Includes: 2 V groove drive rolls and inner wire guide for Steel Wires. (Used on LN-25 Pro)

K487-25 Magnum SG Spool Gun

Hand held semiautomatic wire feeder. Requires SG Control Module and Input Cable.

K488 SG Control Module

The Interface between the power source and the spool gun. Provides control of the wire speed and gas flow. For use with a spool gun.

K691-10 Input Cable (For SG Control Module)

For Lincoln engine power sources with 14-pin MS-type connection, separate 115V NEMA receptacles and output stud connections.

OTHER WIRE FEEDERS USABLE WITH THE VANTAGE 500

- NA-3 or LT-7 Automatic Wire Feeder
- LN-742 Semi-automatic Wire Feeder
- LF-72/74 Semi-automatic Wire feeder
- LN-7 Semi-automatic Wire Feeder
- LN-8 Semi-automatic Wire Feeder
- LN-23P Semi-automatic Wire Feeder
- LN-15 Semi-automatic Wire Feeder

See the Wire Feeder Manual or the Diagrams section of this manual for connection information of the various feeders to the Vantage 500.

VANTAGE® 500



Return to Section TOC Return to Section TOC Return to Section TOC
Return to Master TOC Return to Master TOC Return to Master TOC

Maintenance - VANTAGE® 500 Deutz F4L2011 (Codes 11180,11415)

Safety Precautions D2.2

Routine and Periodic Maintenance D2.2

 Engine Maintenance D2.2

 Change the Oil and Oil Filter D2.2

 Fuel D2.3

 Fuel Filters D2.4

 Air Filter D2.6

 Cooling System D2.7

 Cooling Blower Belt D2.7

Engine Maintenance Schedules and Parts D2.8

Welder/Generator Maintenance D2.8

 Storage D2.8

 Cleaning D2.8

 Nameplates D2.8

 Brush Removal and Replacement D2.8

 Bearings D2.8

 Receptacles D2.8

 Cable Connections D2.8

Battery Maintenance D2.9

 Cleaning the Battery D2.9

 Checking Specific Gravity D2.9

 Checking Electrolyte Level D2.9

 Charging the Battery D2.9

Major Component Locations D2.10

Return to Master TOC

Return to Master TOC

Return to Master TOC

Return to Master TOC

SAFETY PRECAUTIONS

WARNING

- Have qualified personnel do all maintenance and troubleshooting work.
- Turn the engine off before working inside the machine.
- Remove covers or guards only when necessary to perform maintenance and replace them when the maintenance requiring their removal is complete.
- If covers or guards are missing from the machine, get replacements from a Lincoln Distributor.

Read the Safety Precautions in the front of this manual and in the instruction manual for the diesel engine used with your machine before working on the Vantage 500.

Keep all equipment safety guards, covers, and devices in position and in good repair. Keep your hands, hair, clothing, and tools away from the fans, and all other moving parts when starting, operating, or repairing this machine.

ROUTINE AND PERIODIC MAINTENANCE

ENGINE MAINTENANCE

DAILY

- Check the crankcase oil level.
- Refill the fuel tank to minimize moisture condensation in the tank.
- Open the water drain valve located on the bottom of the water separator element one or two turns and allow to drain into a container suitable for diesel fuel for two to three seconds. Repeat the above drainage procedure until diesel fuel is detected in the container.

WEEKLY

Blow out the machine with low pressure air periodically. In particularly dirty locations, this may be required once a week.

CAUTION

To prevent the engine from accidentally starting, disconnect the negative battery cable before servicing the engine.

See the Service Plan section of the Engine Operation Manual for a summary of maintenance intervals for the items listed below. Follow either the hourly or the calendar intervals, whichever come first. More frequent service may be required, depending on your specific application and operating conditions.

OIL: Check the oil level after every 8 hours of operation or daily. BE SURE TO MAINTAIN THE OIL LEVEL.

Change the oil the first time between 25 and 50 hours of operation. Then, under normal operating conditions, change the oil as specified in Service Plan section of the Engine Operation Manual. If the engine is operated under heavy load or in high ambient temperatures, change the oil more frequently.

CHANGE THE OIL AND FILTER

CHANGE THE OIL

Change the oil, while the engine is still warm, as follows:

1. Route the Oil Drain hose through the access hole in the frame. Drain the oil using the ball valve on the lower right side of the engine. See **Figure D2.1**.
2. When the oil is drained, close the ball valve.
3. Remove the oil fill cap and pour in approximately 9 quarts (8.5 L) of oil. Check the dipstick and add oil until the level reaches the "MAX" mark. See **Figure D2.1**. Use high quality oil viscosity grade 10W40. Consult the engine manual for oil specifications for various ambient temperatures. Always check the level with the dipstick before adding more oil. Do not overfill.
4. Reinstall the oil fill cap and the dipstick.

FIGURE D2.1 – ENGINE ASSEMBLY

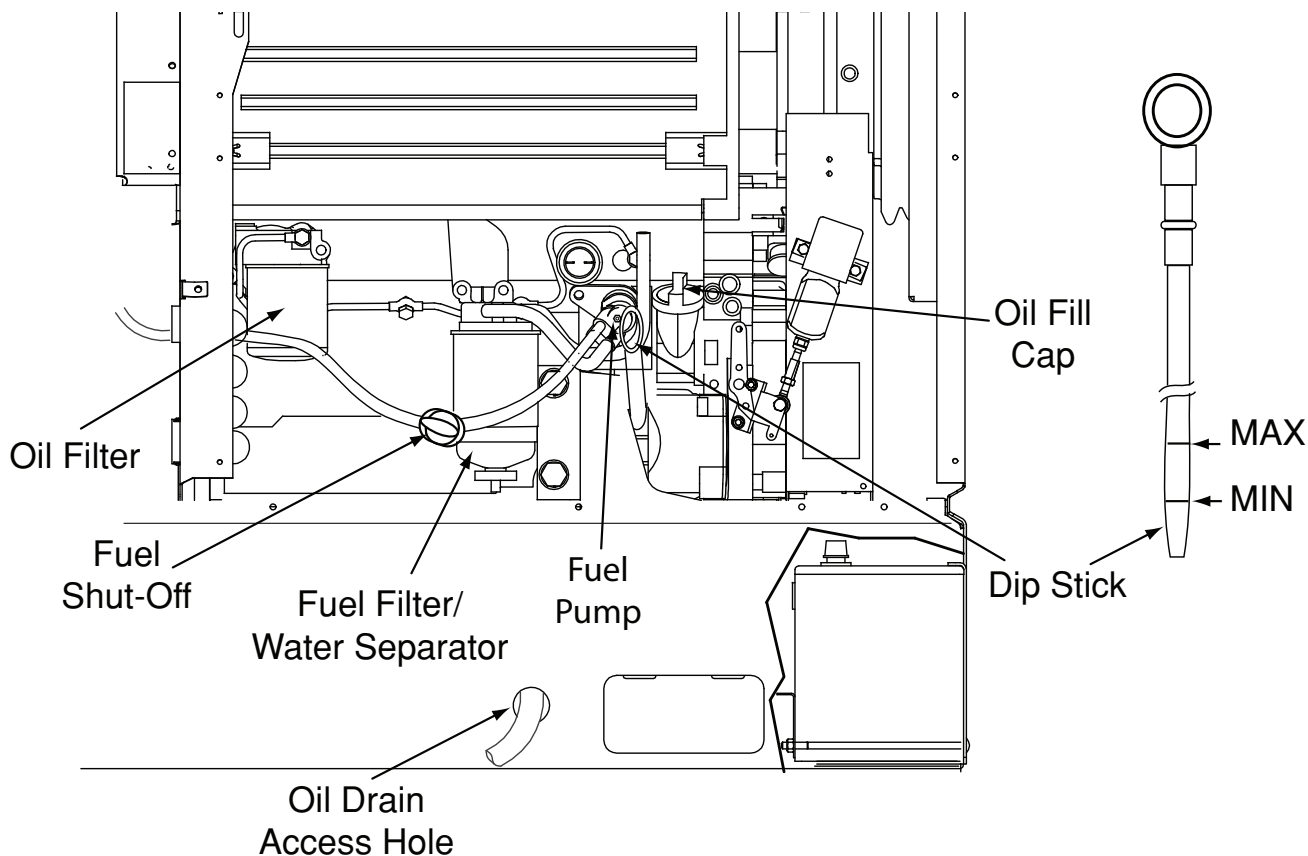

CHANGE THE OIL FILTER

Change the oil filter the first time between 25 and 50 hours of operation. Then, under normal operating conditions, change the oil filter after every 250 hours of operation. If the engine is operated under heavy load or in high ambient temperatures, change the oil filter more frequently. See Service Plan section of the Engine Operation Manual for recommended maintenance intervals. See **Table D2.1** for replacement oil filters.

Change the oil filter as follows:

1. Drain the oil from the engine and allow the oil filter to drain. See Figure D2.1.
2. Remove the old filter (spin it off) and discard it. Wipe off the filter mounting surface and adapter. See Figure D2.1.
3. Fill the new filter with fresh engine oil. Apply a thin coat of new oil to the rubber gasket on the new oil filter.
4. Spin the new filter onto the mounting adapter finger tight until the gasket is evenly seated. Then turn it down another 1/2 turn. Do not overtighten the new filter.

5. Refill the engine with the proper amount and type of oil as described in the **Change the Oil** section. Start the engine and check for leaks around the filter element. Correct any leaks (usually by retightening the filter, but only enough to stop leaks) before placing the Vantage 500 back in service.
6. If there are no leaks, stop the engine and recheck the oil level. If necessary, add oil to bring the level up to the "MAX" mark, but do not overfill. See Figure D2.1.

FUEL

At the end of each day's use, refill the fuel tank to minimize moisture condensation and dirt contamination in the fuel line. Do not overfill; leave room for the fuel to expand.

Refer to your engine operation manual for recommended grade of fuel.

FUEL FILTERS

⚠ WARNING



When working on the fuel system

- Keep naked lights away, do not smoke !
- Do not spill fuel !

The VANTAGE 500 DEUTZ is equipped with a **Fuel Filter/Water Separator** located after the lift pump and before fuel injectors. The procedure for changing the filter is as follows. See Figure D2.2

1. Close the fuel shutoff valve.
2. Clean the area around the fuel filter head. Remove the filter. Clean the gasket surface of the filter head and replace the o-ring.
3. Fill the clean filter with clean fuel, and lubricate the o-ring seal with clean lubricating oil.
4. Install the filter as specified by the filter manufacturer.

⚠ WARNING

Mechanical overtightening will distort the threads, filter element seal or filter can.

There is also a filter screen in the fuel pump that should be checked whenever the Fuel Filter/Water Separator maintenance is performed. See Figure D2.3

- Close the fuel Shut-off valve.
- Remove the hex screw (1) on the top of the fuel pump.
- Remove the cover and strainer (2) and clean the strainer with diesel fuel (replace if necessary).
- Make sure the seal (3) is in place. Replace the strainer and tighten the hex screw.
- Open the fuel valve and check for leaks.

FIGURE D2.3 - FUEL PUMP

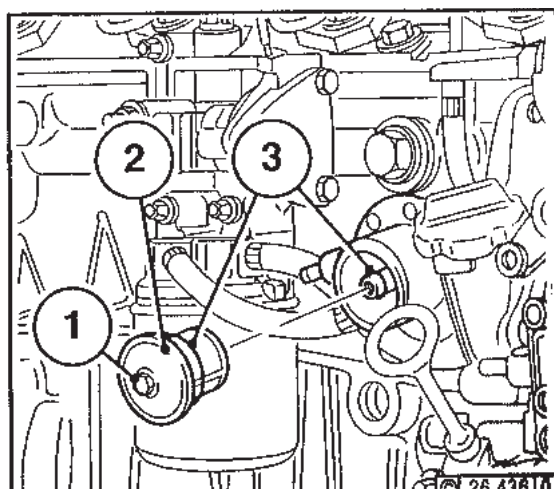
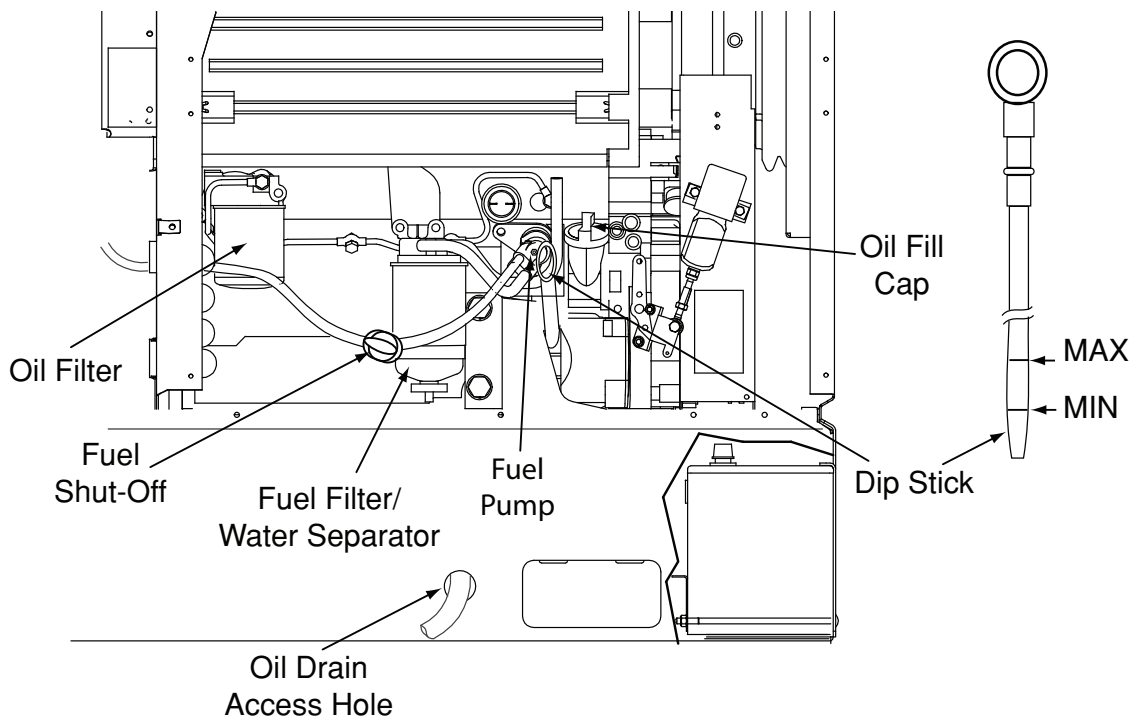

FIGURE D2.2 - ENGINE ASSEMBLY



AIR FILTER:**⚠ CAUTION**

Excessive air filter restriction will result in reduced engine life.

The air filter element is a dry cartridge type. It can be cleaned and reused. However, damaged elements should not be reused. Stop engine after 100 hours of running time and clean filter element. Replace the filter if necessary. Service the air cleaner regularly according to your engine operation manual.

1. Locate the air filter canister located behind the engine door and mounted to the rear panel .
2. Remove the air filter element per the instructions on the **Maintenance Instructions** located on the door. (Also in this manual and the Operator's Manual

3. Remove loose dirt from the element with compressed air or a water hose directed from inside out.

Compressed Air: 100 psi maximum with nozzles at least one inch away from the element.

Water Hose: 40 psi maximum without nozzle.

4. Soak the element in a mild detergent solution for 15 minutes. Do not soak more than 24 hours. Swish the element around in the solution to help remove dirt.
5. Rinse elements from inside out with a gentle stream of water (less than 40 psi) to remove all suds and dirt.
6. Dry the element before reuse with warm air at less than 160°F (71°C). Do not use a light bulb to dry the element.
7. Inspect for holes and tears by looking through the element toward a bright light. Check for damaged gaskets or dented metal parts. Do not reuse damaged elements. Protect the element from dust and damage during drying and storage.
8. Reinstall the air filter element per the Maintenance Decal.

After six cleanings, replace the air filter. See the **Maintenance Instructions**. A cleaned filter will have approximately 70% of the life of a new filter element. A restricted filter element may not appear excessively dirty.

NOTE: If the entire canister is removed or replaced, the spring clamps should be tightened to 15-20 in/lbs. See Figure D2.4

FIGURE D2.4 - AIR CLEANER

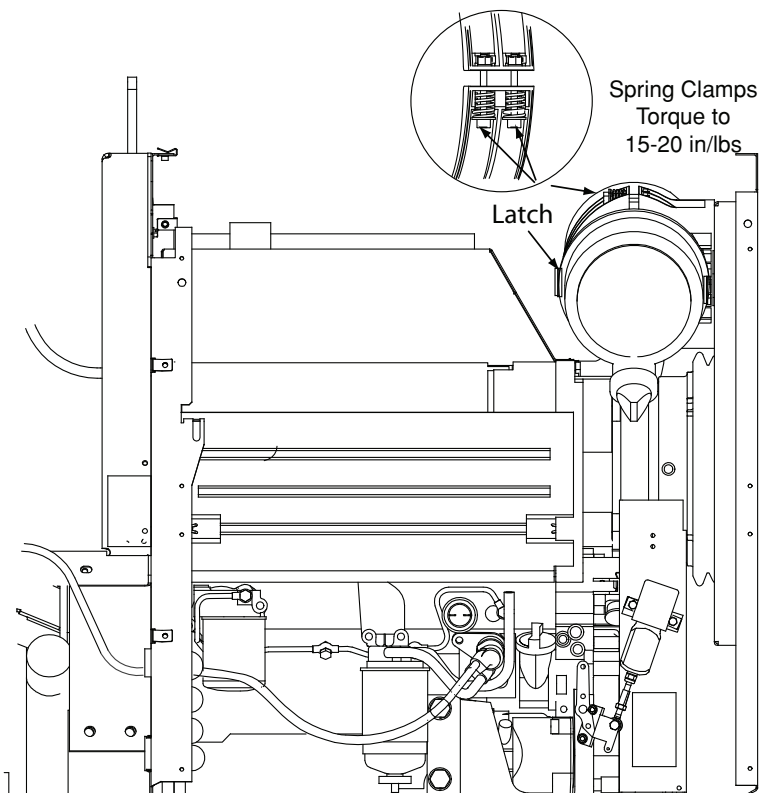

VANTAGE® 500

**LINCOLN®
ELECTRIC**

MAINTENANCE INSTRUCTIONS

Service Instructions

Single- and Two-Stage Engine Air Cleaners

1 Remove the Filter

Rotate the filter while pulling straight out.

Unfasten or unlatch the service cover. Because the filter fits tightly over the outlet tube to create the critical seal, there will be some initial resistance, similar to breaking the seal on a jar. Gently move the end of the filter back and forth to break the seal then rotate while pulling straight out. Avoid knocking the filter against the housing.

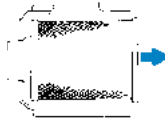

If your air cleaner has a safety filter, replace it every third primary filter change. Remove the safety filter as you would the primary filter. Make sure you cover the air cleaner outlet tube to avoid any unfiltered contaminant dropping into the engine.

2 Clean Both Surfaces of the Outlet Tube and Check the Vacuator™ Valve

Use a clean cloth to wipe the filter sealing surface and the inside of the outlet tube. Contaminant on the sealing surface could hinder an effective seal and cause leakage. Make sure that all contaminant is removed before the new filter is inserted. Dirt accidentally transferred to the inside of the outlet tube will reach the engine and cause wear. Engine manufacturers say that it takes only a few grams of dirt to "dust" an engine! Be careful not to damage the sealing area on the tube.

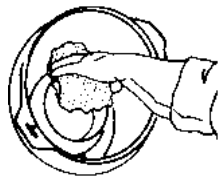

Outer edge of the outlet tube

Wipe both sides of the outlet tube clean.

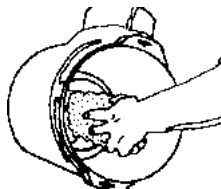

Inner edge of the outlet tube

If your air cleaner is equipped with a Vacuator Valve
Visually check and physically squeeze to make sure the valve is flexible and not inverted, damaged or plugged.

**3 Inspect the Old Filter for Leak Clues**

Visually inspect the old filter for any signs of leaks. A streak of dust on the clean side of the filter is a telltale sign. Remove any cause of leaks before installing new filter.

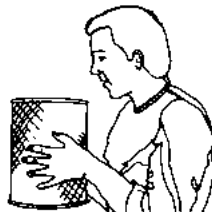
**4 Inspect the New Filter for Damage**

Inspect the new filter carefully, paying attention to the inside of the open end, which is the sealing area. NEVER install a damaged filter. A new Donaldson radial seal filter may have a dry lubricant on the seal to aid installation.

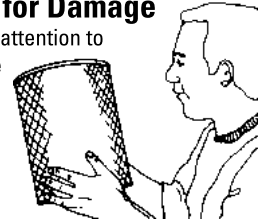
**5 Insert the New Radial Seal Filter Properly**

If you're servicing the safety filter, this should be seated into position before installing the primary filter.

Insert the new filter carefully. Seat the filter by hand, making certain it is completely into the air cleaner housing before securing the cover in place.

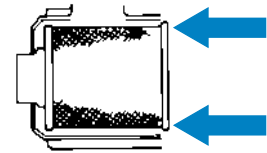

The critical sealing area will stretch slightly, adjust itself and distribute the sealing pressure evenly. To complete a tight seal, apply pressure by hand at the outer rim of the filter, not the flexible center. (Avoid pushing on the center of the urethane end cap.) No cover pressure is required to hold the seal. NEVER use the service cover to push the filter into place! Using the cover to push the filter in could cause damage to the housing, cover fasteners and will void the warranty.

If the service cover hits the filter before it is fully in place, remove the cover and push the filter (by hand) further into the air cleaner and try again. The cover should go on with no extra force.

Once the filter is in place, secure the service cover.

**Caution**

NEVER use the service cover to push the filter into place! Using the cover to push the filter in could cause damage to the housing, cover fasteners and will void the warranty.

**6 Check Connectors for Tight Fit**

Make sure that all mounting bands, clamps, bolts, and connections in the entire air cleaner system are tight. Check for holes in piping and repair if needed. Any leaks in your intake piping will send dust directly to the engine!

COOLING SYSTEM

The cooling system of the Deutz engine needs to be checked and cleaned periodically. Consult the engine Operation Manual for the proper frequency and procedures.

COOLING BLOWER BELT: The following procedure should be followed to replace the cooling blower belt:

1. Allow the machine to cool.
2. Unfasten and slide the battery holder out from the welder.
3. Disconnect the negative battery cable.
4. Remove the engine case side.
5. Loosen the air cleaner hose clamp at the engine and detach the hose.
6. Remove the engine end panel with air box and air cleaner attached for access to the engine.
7. Remove the Idler solenoid from the pulley guard.
8. Remove the pulley gaurd - Note the placement of the flat washer at the upper right mounting bolt of the pulley guard.
9. See Figure D3.5. Loosen the idler pulley mounting bolt and move the pulley toward the engine.
10. Remove the old cooling blower belt and install a new one.
11. Push outward on the idler pulley and adjust the cold belt tension for approximately 10-15 mm (.4-.6 in.) maximum deflection) midway between any two pulleys and tighten the bolt.
12. Reinstall the air cleaner hose, engine case side, and engine end panel. Reattach the negative battery cable. Slide in and refasten the battery holder.
13. Run the engine for 15 minutes and reset the tension per the Engine Operation Manual using a V-belt tension gauge.

FIGURE D2.5 – COOLING BLOWER BELT REPLACEMENT AND ADJUSTING

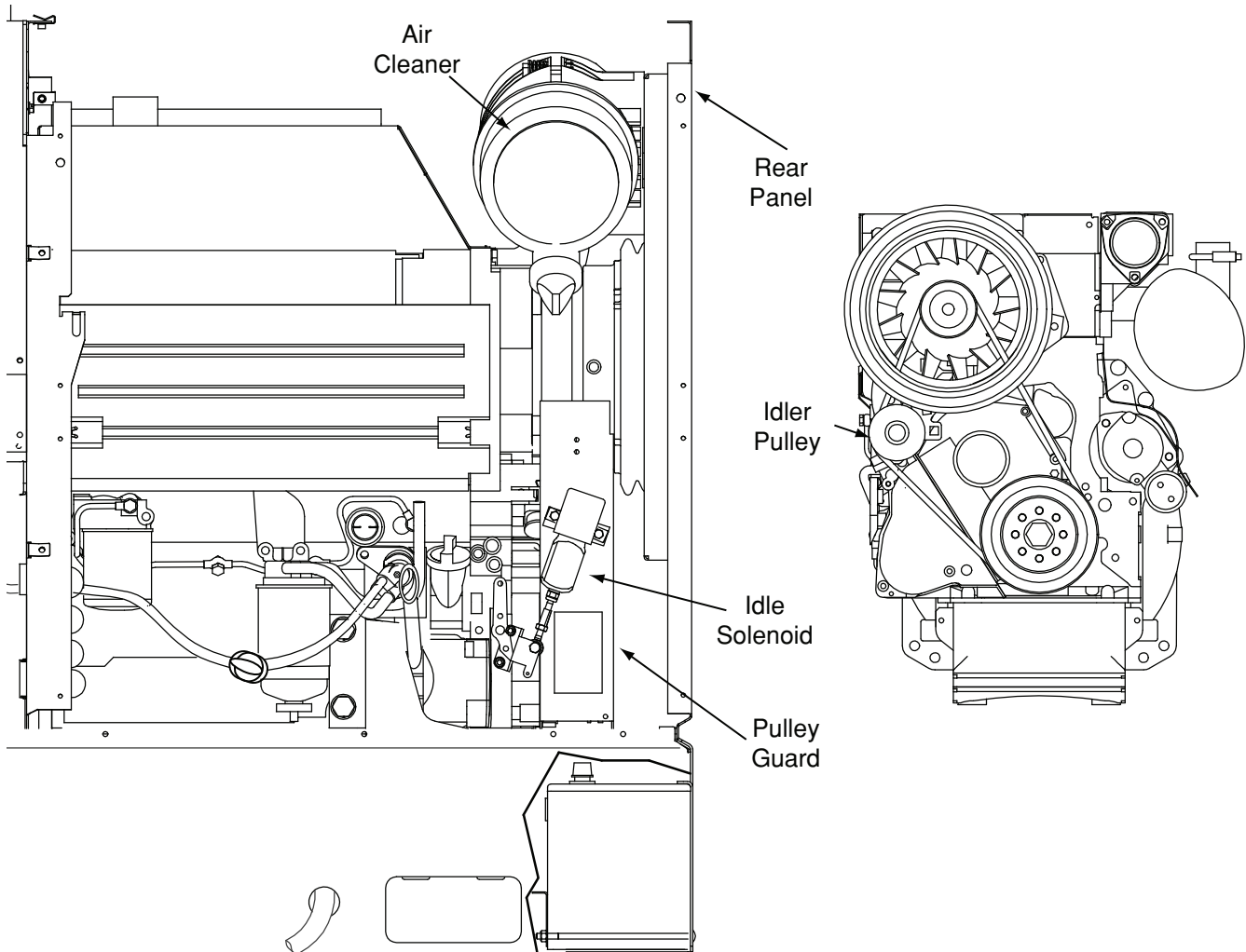

VANTAGE® 500

LINCOLN
ELECTRIC

TABLE D2.1

REPLACEMENT SERVICE ITEMS			
ITEM	MAKE	PART NUMBER	SERVICE INTERVAL
AIR CLEANER ELEMENT	DONALDSON FLEETGUARD	P822768 AF25436	CLEAN AS NEEDED, REPLACE EVERY 200 HOURS.
OIL FILTER ELEMENT	DEUTZ	01174416	SEE DEUTZ MAINTENANCE DECAL
FUEL FILTER/ WATER SEPARATOR ELEMENT	DEUTZ	01174482	
FUEL PUMP STRAINER <small>(NOT ON ALL MACHINES)</small>	DEUTZ	_____	
IN-LINE FUEL PRE-FILTER <small>(NOT ON ALL MACHINES)</small>	DEUTZ	01178753	REPLACE EVERY 500 HOURS.
COOLING BLOWER BELT	DEUTZ	01179564	INSPECT EVERY 500 HOURS
BATTERY	_____	BCI GROUP 34	INSPECT EVERY 500 HOURS

WELDER/GENERATOR MAINTENANCE

STORAGE: Store the Vantage 500 in clean, dry, protected areas.

CLEANING: Blow out the generator and controls periodically with low pressure air. Do this at least once a week in particularly dirty areas.

NAMEPLATES: Whenever routine maintenance is performed on this machine - or at least yearly - inspect all nameplates and labels for legibility. Replace those which are no longer clear. Refer to the parts list for the replacement item number.

BRUSH REMOVAL AND REPLACEMENT: It is normal for the brushes and slip rings to wear and darken slightly. Inspect the brushes when a generator overhaul is necessary.

WARNING

Do not attempt to polish slip rings while the engine is running.

BEARINGS: The Vantage 500 is equipped with double-shielded ball bearings having sufficient grease to last indefinitely under normal service. Where the welder is used constantly or in excessively dirty locations, it may be necessary to add one half ounce of grease per year. A pad of grease one inch wide, one inch long, and one inch high weighs approximately one half ounce. Over-greasing is far worse than insufficient greasing.

When greasing the bearings, keep all dirt out of the area. Wipe the fittings completely clean and use clean equipment. More bearing failures are caused by dirt introduced during greasing than from insufficient grease.

RECEPTACLES: Keep the electrical receptacles in good condition. Remove any dirt, oil, or other debris from their surfaces and holes.

CABLE CONNECTIONS: Check the welding cable connections at the weld output terminals often. Be sure that the connections are always tight.

VANTAGE® 500



BATTERY MAINTENANCE

WARNING



GASES FROM BATTERY can explode.

- Keep sparks, flame, and cigarettes away from battery.



BATTERY ACID can burn eyes and skin.

- Wear gloves and eye protection and be careful when working near a battery. Follow the instructions printed on the battery.

To prevent **EXPLOSION** when:



- **INSTALLING A NEW BATTERY -** Disconnect the negative cable from the old battery first and connect to the new battery last.

- **THE CORRECT POLARITY IS NEGATIVE GROUND -** Damage to the engine alternator and the printed circuit board can result from incorrect connection.
- **CONNECTING A BATTERY CHARGER -** Remove the battery from the welder by disconnecting the negative cable first, then the positive cable and battery clamp. When reinstalling, connect the negative cable last. Keep the area well ventilated.
- **USING A BOOSTER -** Connect the positive lead to the battery first, then connect the negative lead to the engine foot.
- To prevent **BATTERY BUCKLING**, tighten the nuts on the battery clamp until snug.

CLEANING THE BATTERY: Keep the battery clean by wiping it with a damp cloth when dirty. If the terminals appear corroded, disconnect the battery cables and wash the terminals with an ammonia solution or a solution of 1/4 pound (0.113 kg) of baking soda and 1 quart (0.946 l) of water. Be sure the battery vent plugs (if equipped) are tight so that none of the solution enters the cells.

After cleaning, flush the outside of the battery, the battery compartment, and surrounding areas with clear water. Coat the battery terminals lightly with petroleum jelly or a non-conductive grease to retard corrosion.

Keep the battery clean and dry. Moisture accumulation on the battery can lead to more rapid discharge and early battery failure.

CHECKING SPECIFIC GRAVITY: Check each battery cell with a hydrometer. A fully charged battery will have a specific gravity of 1.260. Charge the battery if the reading is below 1.215.

NOTE: Correct the specific gravity reading by adding four gravity points (0.004) for every five degrees the electrolyte temperature is above 80 degrees F (27 degrees C). Subtract four gravity points (.004) for every five degrees the electrolyte temperature is below 80 degrees F (27 degrees C).

CHECKING ELECTROLYTE LEVEL: If battery cells are low, fill them to the neck of the filler hole with distilled water and recharge. If one cell is low, check for leaks.

CHARGING THE BATTERY: The Vantage 500 is equipped with a wet charged battery. The charging current is automatically regulated when the battery is low (after starting the engine) to a trickle current when the battery is fully charged.

When you charge, jump, replace, or otherwise connect battery cables to the battery, be sure the polarity is correct. Improper polarity can damage the charging circuit. **The Vantage 500 charging system is NEGATIVE GROUND.** The positive (+) battery terminal has a red terminal cover.

If you need to charge the battery with an external charger, disconnect the negative cable first, then the positive cable before you attach the charger leads. After the battery is charged, reconnect the positive battery cable first and the negative cable last. Failure to do so can result in damage to the internal charger components.

Follow the instructions of the battery charger manufacturer for proper charger settings and charging time.

FIGURE D2.6 – MAJOR COMPONENT LOCATIONS

- | | |
|----------------------------------|------------------------|
| 1. CONTROL PANEL ASSEMBLY | 6. ENGINE ASSEMBLY |
| 2. CONTROL BOX & OUTPUT ASSEMBLY | 7. GENERATOR |
| 3. POWER MODULE ASSEMBLY | 8. SOLENOID ASSEMBLY |
| 4. BASE & LIFT BAILE ASSEMBLY | 9. CASEBACK |
| 5. FUEL TANK & MOUNTING | 10. CASE TOP AND SIDES |

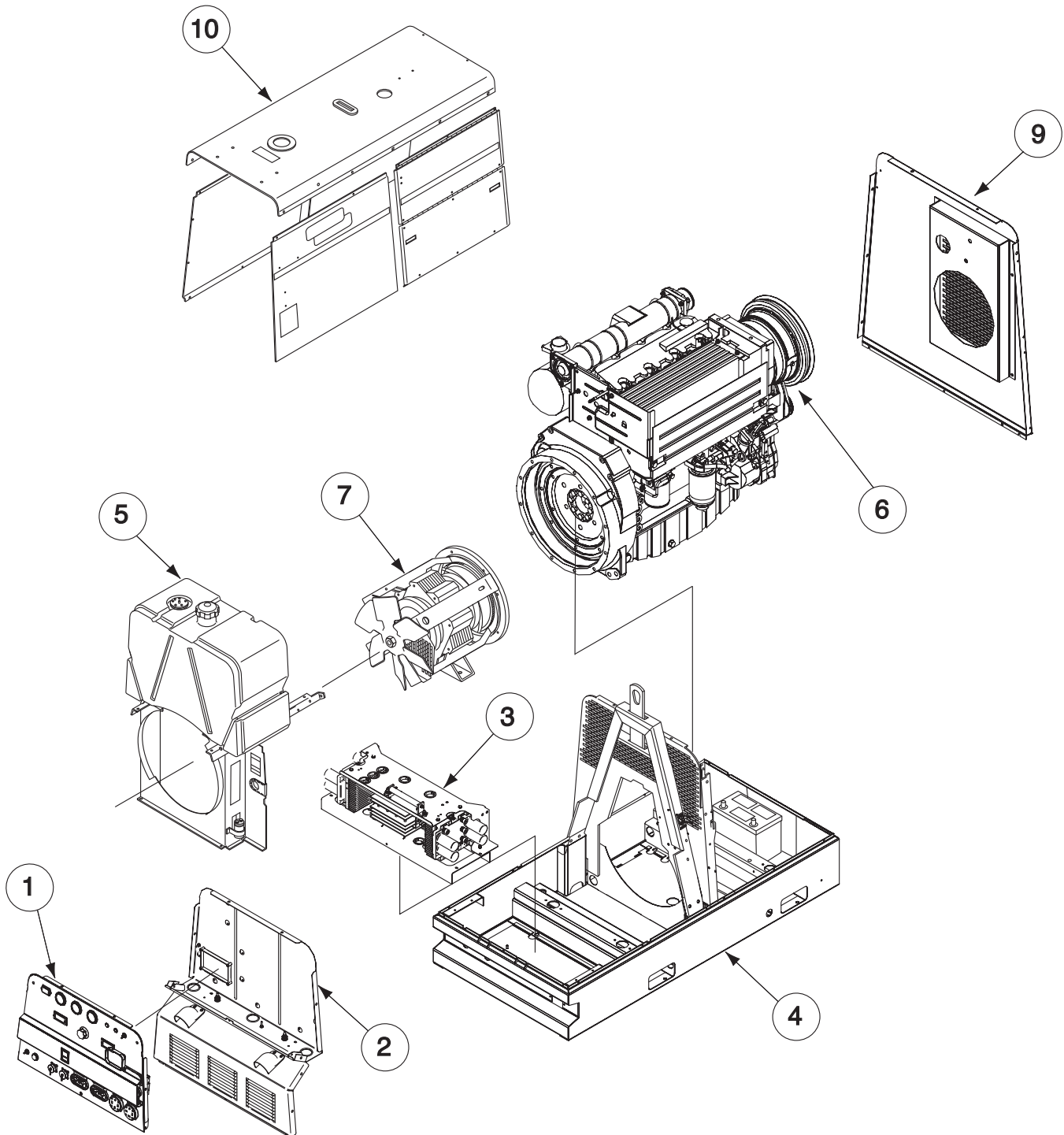

VANTAGE® 500

Installation - VANTAGE® 500 Deutz D2011L4i (Code11468)

Technical Specifications	A3.2
Safety Precautions	A3.3
Location/Ventilation	A3.3
Storing	A3.3
Stacking	A3.3
Angle of Operation	A3.3
Lifting	A3.4
High Altitude Operation	A3.4
High Temperature Operation	A3.4
Towing	A3.4
Vehicle Mounting	A3.4
Pre-Operation Engine Service	A3.5
Oil	A3.5
Fuel	A3.5
Fuel Cap	A3.5
Engine Cooling System	A3.5
Battery Connection	A3.5
Muffler Outlet Pipe	A3.6
Spark Arrester	A3.6
High Frequency Generators for TIG Applications	A3.6
Electrical Connections	A3.6
Remote Control	A3.6
Welding Terminals	A3.6
Welding Output Cables	A3.7
Machine Grounding	A3.7
Auxiliary Power Receptacles	A3.7
Standby Power Connections	A3.7

TECHNICAL SPECIFICATIONS - VANTAGE® 500 DEUTZ (K2405-2)
INPUT - DIESEL ENGINE

Make /Model	Description	Speed (RPM)	Displacement	Starting System	Capacities
DEUTZ D 2011 L4i Diesel Engine EPA Tier 4 interim Compliant	4 cylinder 48HP (36 kw) @ 1800 RPM	High Idle 1890 Low Idle 1425 Full Load 1800	190 cu. in (3.1L) Bore x Stroke 3.70" x 4.41" (94mm x 112mm)	12VDC battery & Starter	Fuel 25 US gal. (94.6L) Oil: 2.5 US gal. (9.5L)

RATED OUTPUT @ 104°F(40°C) - WELDER

Duty Cycle	Welding Output	Volts at Rated Amps
100%	500 Amps (DC multi-purpose)	40 Volts
60%	550 Amps (DC multi-purpose)	36 volts
50%	575 Amps (DC multi-purpose)	35 volts

OUTPUT @ 104°F(40°C) - WELDER AND GENERATOR
Welding Range

30 - 575 Amps CC/CV
20 - 250 Amps TIG

Open Circuit Voltage

60 Max OCV @ 1900 RPM

Auxiliary Power ⁽¹⁾

120/240 VAC
12,000 WATTS, 60 Hz., Single Phase
20,000 WATTS, 60 Hz., Three Phase

PHYSICAL DIMENSIONS

Height ⁽²⁾	Width	Depth	Weight
42.0 in (1066.8 mm)	31.5 in. (800.1mm)	63.1 in. (1603mm)	1532lbs. (695kg) (Approx)

- Output rating in watts is equivalent to volt-amperes at unity power factor.
Output voltage is within +/- 10% at all loads up to rated capacity. When welding, available auxiliary power will be reduced.
- Top of Enclosure. Add 8.9" (226mm) for exhaust.

VANTAGE® 500

Read this entire installation section before you start installation.

SAFETY PRECAUTIONS



WARNING

Do not attempt to use this equipment until you have thoroughly read all operating and maintenance manuals supplied with your machine. They include important safety precautions, detailed engine starting, operating and maintenance instructions and parts lists.

ELECTRIC SHOCK can kill.



- Do not touch electrically live parts such as output terminals or internal wiring.
- Insulate yourself from the work and ground.
- Always wear dry insulating gloves.

ENGINE EXHAUST can kill.



- Use in open, well ventilated areas or vent exhaust outside
- Do not stack anything near the engine.

MOVING PARTS can injure.



- Do not operate with doors open or guards off.
- Stop engine before servicing.
- Keep away from moving parts

Only qualified personnel should install, use or service this equipment

LOCATION / VENTILATION

The welder should be located to provide an unrestricted flow of clean, cool air to the cooling air inlets and to avoid restricting the cooling air outlets. Also, locate the welder so that the engine exhaust fumes are properly vented to an outside area.



CAUTION

DO NOT MOUNT OVER COMBUSTIBLE SURFACES

Where there is a combustible surface directly under stationary or fixed electrical equipment, that surface should be covered with a steel plate at least .06”(1.6mm) thick, which should extend not less than 5.90”(150mm) beyond the equipment on all sides.

STORING

1. Store the machine in a cool, dry place when it is not in use. Protect it from dust and dirt. Keep it where it can't be accidentally damaged from construction activities, moving vehicles, and other hazards.
2. Drain the engine oil and refill with fresh 10W30 oil. Run the engine for about five minutes to circulate oil to all the parts. See the **MAINTENANCE** section of this manual for details on changing oil.
3. Remove the battery, recharge it, and adjust the electrolyte level. Store the battery in a dry, dark place.

STACKING

Vantage 500 machines cannot be stacked.

ANGLE OF OPERATION

To achieve optimum engine performance the Vantage should be run in a level position. The maximum angle of operation for the Cummins engine is 35 degrees in all directions. If the engine is to be operated at an angle, provisions must be made for checking and maintaining the oil level at the normal (FULL) oil capacity in the crankcase. When operating the welder at an angle, the effective fuel capacity will be slightly less than the specified 25 gallons.

LIFTING

The Vantage lift bale should be used to lift the machine. The Vantage is shipped with the lift bale retracted. Before attempting to lift the Vantage, secure the lift bale in a raised position. Secure the lift bale as follows:

- Open the engine compartment door.
- Locate the two access holes on the upper middle region of the compartment wall just below the lift bale.
- Use the lifting strap to raise the lift bale to the full upright position. This will align the mounting holes on the lift bale with the access holes.
- Secure the lift bale with 2 thread forming screws. The screws are provided in the loose parts bag shipped with the machine.

WARNING



FALLING EQUIPMENT can cause injury.

- Do not lift this machine using lift bale if it is equipped with a heavy accessory such as a trailer or gas cylinder.
- Lift only with equipment of adequate lifting capacity.
- Be sure machine is stable when lifting.

HIGH ALTITUDE OPERATION

At higher altitude, output derating may be necessary. For maximum rating, derate the welder output 5% for every 300 meters (984 ft.) above 1500 meters (4920 ft.). For output of 500A and below, derate the welder output 5% for every 300 meters (984 ft.) above 2100 meters (6888 ft.)

Contact a Deutz Service Representative for any engine adjustments that may be required.

HIGH TEMPERATURE OPERATION

At temperatures above 40°C (104°F), output voltage derating may be necessary. For maximum output current ratings, derate the welder voltage rating two volts for every 10°C (21°F) above 40°C (104°F).

TOWING

The recommended trailer for use with this equipment for road, in-plant and yard towing by a vehicle¹ is Lincoln's K2636-1. If the user adapts a non-Lincoln trailer, he must assume responsibility that the method of attachment and usage does not result in a safety hazard nor damage the welding equipment. Some of the factors to be considered are as follows:

- Design capacity of the trailer vs. weight of the Lincoln equipment and likely additional attachments.
- Proper support of, and attachment to, the base of the welding equipment so that there will be no undue stress to the trailer's framework.
- Proper placement of the equipment on the trailer to insure stability side to side and front to back when being moved and when standing by itself.
- Typical conditions of use, such as travel speed, roughness of surface on which the trailer will be operated, and environmental conditions.
- Proper preventative maintenance of the trailer.
- Conformance with federal, state and local laws.¹

¹Consult applicable federal, state and local laws regarding specific requirements for use on public highways.

VEHICLE MOUNTING

WARNING

Improperly mounted concentrated loads may cause unstable vehicle handling and tires or other components to fail.

- Only transport this Equipment on serviceable vehicles which are rated and designed for such loads.
- Distribute, balance and secure loads so vehicle is stable under conditions of use.
- Do not exceed maximum rated loads for components such as suspension, axles and tires.
- Mount equipment base to metal bed or frame of vehicle.
- Follow vehicle manufacturer's instructions.

PRE-OPERATION ENGINE SERVICE

READ the engine operating and maintenance instructions supplied with this machine.

WARNING



- Keep hands away from the engine muffler or HOT engine parts.
- Stop engine and allow to cool before fueling.

- Do not smoke when fueling.
- Fill fuel tank at a moderate rate and do not over-fill.
- Wipe up spilled fuel and allow fumes to clear before starting engine.
- Keep sparks and flame away from tank.

OIL

The Vantage is shipped with the engine crankcase filled with high quality SAE 10W-30 oil (API class CD or better). Check the oil level before starting the engine. If it is not up to the full mark on the dip stick, add oil as required. Check the oil level every four hours of running time during the first 35 running hours. Refer to the engine Operator's Manual for specific oil recommendations and break-in information. The oil change interval is dependent on the quality of the oil and the operating environment. Refer to the engine Operator's Manual for the proper service and maintenance intervals.

FUEL

NOTE: USE DIESEL FUEL ONLY.



Fill the fuel tank with clean, fresh diesel fuel. The capacity of the fuel tank is approx 95 liters. See engine Operator's Manual for specific fuel recommendations. **Running out of fuel may require bleeding the fuel injection pump.** **NOTE:** Before starting the engine, open the fuel shutoff valve (pointer to be in line with hose).

NOTE: Before starting the engine, open the fuel shutoff valve (pointer to be in line with hose).

FUEL CAP

Remove the plastic cap covering from the fuel tank filler neck and install the fuel cap.

ENGINE COOLING SYSTEM

The Deutz engine is air cooled by a belt-driven axial blower. The oil cooler and engine cooling fins should be blown out with compressed air or steam to maintain proper cooling. (See the engine Operator's Manual for procedures and frequency.)

BATTERY CONNECTION

WARNING



GASES FROM BATTERY can explode.

- Keep sparks, flame and cigarettes away from battery.

To prevent EXPLOSION when:

- **INSTALLING A NEW BATTERY** — disconnect negative cable from old battery first and connect to new battery last.
- **CONNECTING A BATTERY CHARGER** — remove battery from welder by disconnecting negative cable first, then positive cable and battery clamp. When reinstalling, connect negative cable last. Keep well ventilated.
- **USING A BOOSTER** — connect positive lead to battery first then connect negative lead to negative battery lead at engine foot.



BATTERY ACID can burn eyes and skin.

- Wear gloves and eye protection and be careful when working near battery.
- Follow instructions printed on battery.

IMPORTANT: To prevent ELECTRICAL DAMAGE WHEN:

- a) Installing new batteries
- b) Using a booster

Use correct polarity — **Negative Ground.**

The Vantage is shipped with the negative battery cable disconnected. Before you operate the machine, make sure the Engine Switch is in the OFF position and attach the disconnected cable securely to the negative (-) battery terminal.

Remove the insulating cap from the negative battery terminal. Replace and tighten the negative battery cable terminal.

NOTE: This machine is furnished with a wet charged battery; if unused for several months, the battery may require a booster charge. Be sure to use the correct polarity when charging the battery.

MUFFLER OUTLET PIPE

Remove the plastic plug covering the muffler outlet tube. Using the clamp provided, secure the outlet pipe to the outlet tube with the pipe positioned to direct the exhaust in the desired direction.

SPARK ARRESTER

Some federal, state or local laws may require that gasoline or diesel engines be equipped with exhaust spark arresters when they are operated in certain locations where unarrested sparks may present a fire hazard. The standard muffler included with this welder does not qualify as a spark arrester. When required by local regulations, a suitable spark arrester must be installed and properly maintained.



CAUTION

An incorrect arrester may lead to damage to the engine or adversely affect performance.

HIGH FREQUENCY GENERATORS FOR TIG APPLICATIONS

The K799 Hi-Freq Unit (obsolete) and the K930-1 or-2 TIG Module are suitable for use with the Vantage 500. The Vantage 500 is equipped with the required R.F. bypass circuitry for the connection of high frequency generating equipment. The high frequency bypass network supplied with the K799 Hi-Freq Unit does NOT need to be installed into the Vantage 500.

The Vantage 500 and any high frequency generating equipment must be properly grounded. See the K799 Hi-Freq Unit and the K930-1 or-2 TIG Module operating manuals for complete instructions on installation, operation, and maintenance.

ELECTRICAL CONNECTIONS

REMOTE CONTROL

The Vantage 500 is equipped with a 6-pin and a 14-pin connector. The 6-pin connector is for connecting the K857 or K857-1 Remote Control (optional) or, in the case of TIG welding applications, with the foot or hand Amptrol (K870 or K963-1 respectively).

The 14-pin connector is used to directly connect a wire feeder or TIG Module (K930-1 or-2) control cable.

NOTE: When using the 14-pin connector, if the wire feeder has a built-in power source output control, do not connect anything to the 6-pin connector.

WELDING TERMINALS

The Vantage is equipped with a toggle switch for selecting "hot" welding terminals when in the "WELD TERMINALS ON" position or "cold" welding terminals when in the "WELDING TERMINALS REMOTELY CONTROLLED" position.

WELDING OUTPUT CABLES

With the engine off, route the electrode and work cables through the strain relief bracket provided on the front of the base and connect to the terminals provided. These connections should be checked periodically and tightened if necessary.

Listed in Table A3.1 are copper cable sizes recommended for the rated current and duty cycle. Lengths stipulated are the distance from the welder to work and back to the welder again. Cable sizes are increased for greater lengths primarily for the purpose of minimizing cable voltage drop.

TABLE A3.1 – COMBINED LENGTH OF ELECTRODE AND WORK CABLES

Amps @ 100% Duty Cycle	Total Combined Length of Electrode and Work Cables		
	Up to 150 ft.	150-200 ft.	200-250 ft.
500	3/0 AWG	3/0 AWG	4/0 AWG

MACHINE GROUNDING

Because this portable engine driven welder creates its own power, it is not necessary to connect its frame to an earth ground, unless the machine is connected to premises wiring (home, shop, etc.).

To prevent dangerous electric shock, other equipment powered by this engine driven welder must:

- a) be grounded to the frame of the welder using a grounded type plug,

or

- b) be double insulated.

When this welder is mounted on a truck or trailer, its frame must be securely connected to the metal frame of the vehicle. When this engine driven welder is connected to premises wiring such as that in a home or shop, its frame must be connected to the system earth ground. See further connection instructions in the section entitled **Standby Power Connections** as well as the article on grounding in the latest U.S. National Electrical Code and the local code.

In general, if the machine is to be grounded, it should be connected with a #8 or larger copper wire to a solid earth ground such as a metal water pipe going into the ground for at least ten feet and having no insulated joints, or to the metal framework of a building which has been effectively grounded. The U.S. National Electrical Code lists a number of alternate means of grounding electrical equipment. A machine grounding stud marked with the \oplus symbol is provided on the front of the welder.

AUXILIARY POWER RECEPTACLES

The auxiliary power capacity of the Vantage 500 is 12,000 watts of 60 Hz, single-phase power. The auxiliary power capacity rating in watts is equivalent to volt-amperes at unity power factor. The maximum permissible current of the 240 VAC output is 50 A. The 240 VAC output can be split to provide two separate 120 VAC outputs with a maximum permissible current of 50 A per output to two separate 120 VAC branch circuits. The output voltage is within $\pm 10\%$ at all loads up to rated capacity.

NOTE: The 120/240V receptacle has two 120V outlets of different phases and cannot be paralleled.

The Vantage has two 20A-120VAC (5-20R) duplex receptacles and one 50A-120/240 VAC (14-50R) receptacle. The 120/240 VAC receptacle can be split for single-phase 120 VAC operation. The auxiliary power receptacles should only be used with three-wire grounded type plugs or approved double insulated tools with two-wire plugs. The current rating of any plug used with the system must be at least equal to the current capacity of the associated receptacle.

STANDBY POWER CONNECTIONS

The Vantage 500 is suitable for temporary, standby or emergency power using the engine manufacturer's recommended maintenance schedule.

The Vantage 500 can be permanently installed as a standby power unit for 240 volt, three-wire, 50 amp service. Connections must be made by a licensed electrician who can determine how the 120/240 VAC power can be adapted to the particular installation and comply with all applicable electrical codes. The following information can be used as a guide by the electrician for most applications. Refer to the connection diagram shown in **Figure A3.1**.

1. Install the double-pole, double-throw switch between the power company meter and the premises disconnect.
- Switch rating must be the same or greater than the customer's premises disconnect and service over current protection.
2. Take necessary steps to assure load is limited to the capacity of the Vantage by installing a 50 amp, 240 VAC double-pole circuit breaker. Maximum rated load for each leg of the 240 VAC auxiliary is 50 amperes. Loading above the rated output will reduce output voltage below the allow-

able -10% of rated voltage, which may damage appliances or other motor-driven equipment and may result in overheating of the Vantage 500 engine.

3. Install a 50 amp 120/240 VAC plug (NEMA Type 14-50) to the double-pole circuit breaker using four-conductor cable of the proper size and desired length. (The 50 amp, 120/240 VAC plug is available in the optional K802R plug kit.)
4. Plug this cable into the 50 amp 120/240 volt receptacle on the Vantage 500 case front.

Figure A3.1 Connection of the Vantage to Premises Wiring

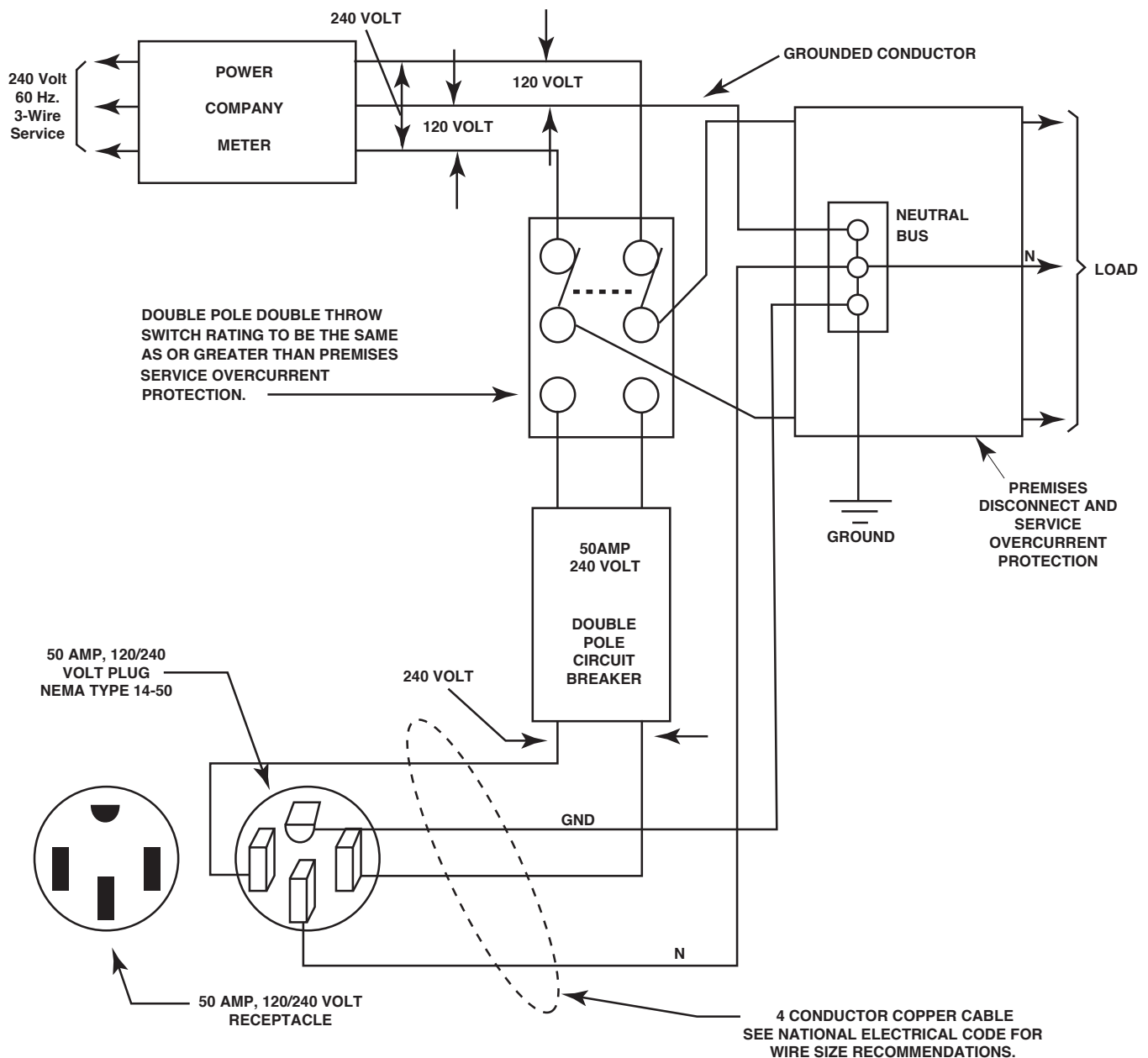

Operation - VANTAGE® 500 Deutz D2011L4i (Code 11468)

Operating Instructions	B3.2
Safety Instructions	B3.2
General Description	B3.2
Recommended Applications	B3.3
Design Features and Advantages	B3.3
Controls and Settings	B3.4
Engine Controls	B3.4
Welding Controls	B3.6
Auxiliary Power Controls	B3.6
Engine Operation	B3.7
Starting the Engine	B3.7
Stopping the Engine	B3.7
Break-In Period	B3.7
Typical Fuel Consumption	B3.7
Welder Operation	B3.8
Stick Welding	B3.8
Constant Current (CC) Welding	B3.8
Pipe Welding	B3.8
TIG Welding	B3.8
Wire Feed (Constant Voltage) Welding	B3.10
Auxiliary Power Operation	B3.10
Arc Gouging	B3.10
Paralleling	B3.10
Simultaneous Welding and Auxiliary Power Loads	B3.11
Extension Cord Recommendations	B3.11

Return to Master TOC

Return to Master TOC

Return to Master TOC

Return to Master TOC

OPERATING INSTRUCTIONS

Read and understand this entire section before operating your Vantage 500.

SAFETY INSTRUCTIONS

WARNING

Do not attempt to use this equipment until you have thoroughly read all operating and maintenance manuals supplied with your machine. They include important safety precautions: detailed engine starting, operating, and maintenance instructions and parts lists.

ELECTRIC SHOCK can kill.



- Do not touch electrically live parts or electrodes with your skin or wet clothing.
- Insulate yourself from the work and ground.
- Always wear dry insulating gloves.

FUMES AND GASES CAN BE DANGEROUS.



- Keep your head out of fumes.
- Use ventilation or exhaust to remove fumes from breathing zone.

WELDING SPARKS CAN CAUSE FIRE OR EXPLOSION.



- Keep flammable material away.
- Do not weld on containers that have held combustibles.

ARC RAYS CAN BURN.



- Wear eye, ear, and body protection.



ENGINE EXHAUST can kill.

- Use in open, well ventilated areas or vent exhaust outside
- Do not stack anything near the engine.



MOVING PARTS can injure.

- Do not operate with doors open or guards off.
- Stop engine before servicing.
- Keep away from moving parts

Only qualified personnel should operate this equipment.

ADDITIONAL SAFETY PRECAUTIONS

Always operate the welder with the hinged door closed and the side panels in place, as these provide maximum protection from moving parts and insure proper cooling air flow.

GENERAL DESCRIPTION

The Vantage 500 is a diesel engine-driven welding power source. The machine uses a brush type alternating current generator for DC multi-purpose welding and for 120/240VAC single phase and 240VAC three phase auxiliary standby power. The welding control system uses state of the art **Chopper Technology**.

The generator has a single sealed bearing for maintenance free service. The rotor is a copper wound design with two slip rings and brushes. The stator is wound entirely with heavy gauge copper wire and insulated with NEMA class F insulation material. The stator is then impregnated with three layers of high quality varnish. After the stator is assembled using tie bars, the entire assembly is covered with an environmentally protective coating. These measures insure trouble-free operation in the harshest environments.

The fuel tank is made from high density polyethylene and holds 25 gallons (94.6 liters) of diesel fuel. This will provide enough fuel to run for more than 12 hours at full load.

The Deutz F3L-912 engine is equipped with a standard, heavy duty, combination fuel filter/water separator element.

RECOMMENDED APPLICATIONS

WELDER

The Vantage 500 provides excellent constant current DC welding output for stick (SMAW) and TIG welding. The Vantage 500 also provides excellent constant voltage DC welding output for MIG (GMAW) and Innershield (FCAW) welding.

GENERATOR

The Vantage 500 provides smooth 120/240 VAC output for auxiliary power and emergency standby power.

DESIGN FEATURES AND ADVANTAGES

K1639-2 VANTAGE 500 DELUXE MODEL FEATURES

FOR WELDING

- Excellent DC multi-purpose welding for stick, MIG, TIG, cored wire and arc gouging applications.
- 30 to 500 amps output in five slope-controlled ranges for out-of position and pipe electrodes, one constant current output range for general purpose welding, one constant voltage range for MIG wire and cored wire welding and one 20-250 amp range for "Touch Start" TIG welding.
- 100% duty cycle at 500 amps output and 50% duty cycle at 575 amps output.
- Dual 3-digit output meters are provided (optional on K1639-1) for presetting the weld amperage or voltage and displaying the actual amperage and voltage during welding. The meters use superbrite L.E.D.'s for improved readability in full sunlight.

LOOK-BACK FEATURE: After welding has stopped, both displays will remain on for 7 seconds with the last current and voltage value displayed. During this time, the left-most decimal point in each display will be FLASHING.

- Standard remote control capability with 14-pin and 6-pin connectors for easy connection of Lincoln remote control accessories.
- An internal "Solid State" contactor allows for the selection of "hot" or "cold" output terminals with a toggle switch on the control panel.
- "Arc Control" potentiometer in Wire and Stick modes for precise adjustment of arc characteristics.
- Advanced circuitry to prevent pop-outs in the five slope modes.

FOR AUXILIARY POWER

- 12,000 watts of 120/240 VAC, 60Hz auxiliary power.
- Power for tools, 120/240 VAC lights, electric pumps and for standby emergency power.
- Drive a 5 HP motor (provided it is started under no load).
- Two 20 amp 120 VAC duplex receptacles for up to 40 amps of 120 VAC power.
- One 50 amp, 120/240 VAC dual voltage receptacle for up to 50 amps of 240 VAC, and up to 50 amps per side to separate branch circuits (not in parallel) of 120 VAC single-phase auxiliary power. Allows easy connection to premises wiring.
- Weld and AC auxiliary power at the same time (within machine total capacity).

OTHER FEATURES

- Deutz 3-cylinder, air/oil cooled diesel engine. Designed for long life, easy maintenance, and excellent fuel economy.
- Engine protection system shuts the engine down for low oil pressure, high oil temperature, or a broken fan/engine alternator belt.
- Gauges for oil pressure, oil temperature, engine alternator output, and fuel level.
- Indicator lights for Engine Protection, and Battery (engine alternator low output/broken belt).
- Engine hour meter standard on all models.
- Extended range 25 gallon (94.6 l) fuel tank.
- Automatic idler reduces engine speed when not welding or drawing auxiliary power. This feature reduces fuel consumption and extends engine life.
- Compact size fits crosswise in full size pickup truck.
- Single-side engine service.
- Copper alternator windings and high temperature insulation for dependability and long life.
- New paint system on case and base for outstanding corrosion protection.

VANTAGE® 500



CONTROLS AND SETTINGS

All welder and engine controls are located on the case front panel. Refer to Figure B.1 and the explanations that follow.

Figure B3.1 Case Front Panel Controls

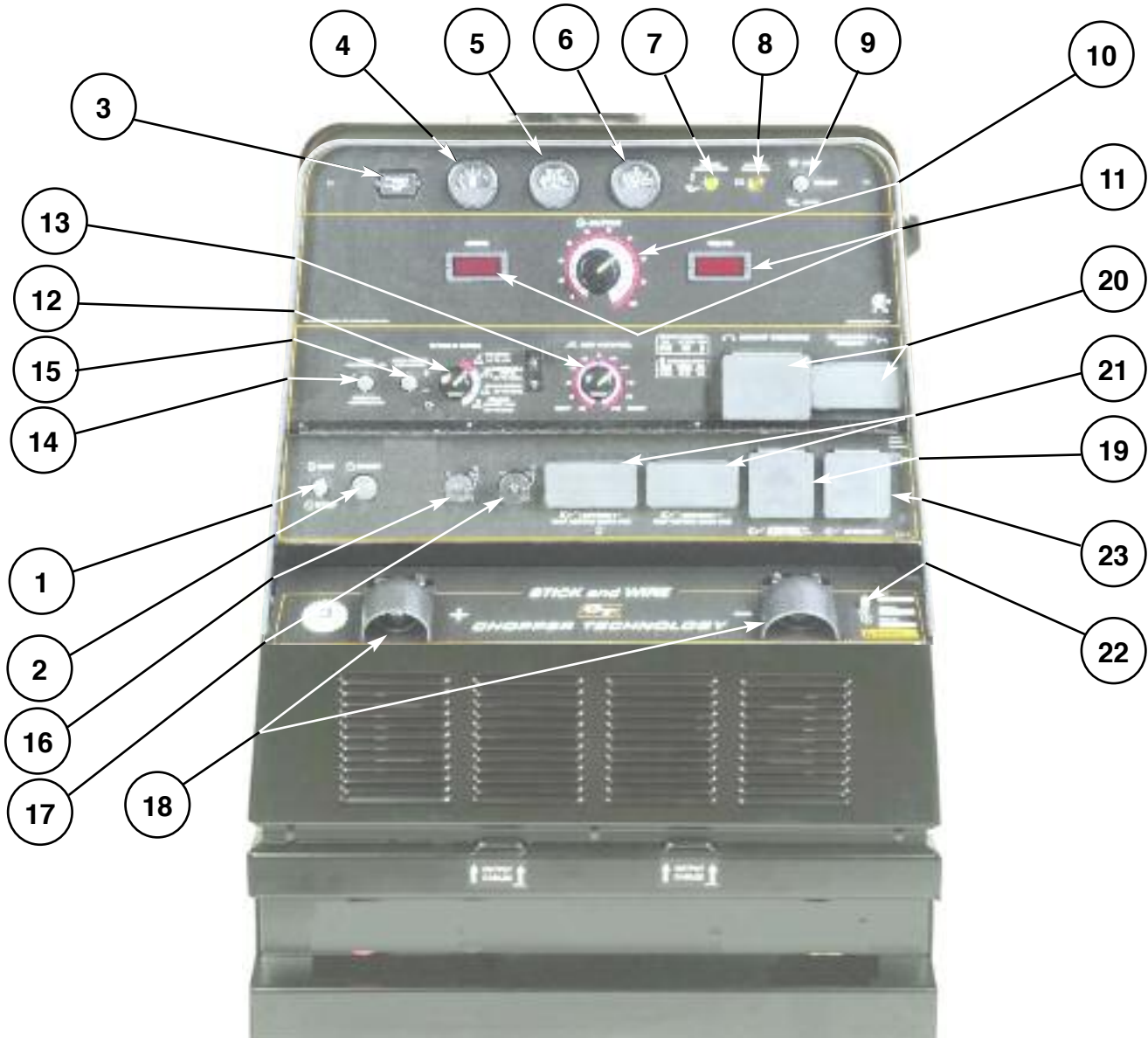

ENGINE CONTROLS (Items 1 through 9)

1. RUN STOP SWITCH

Toggling the switch to the RUN position energizes the fuel solenoid for approximately 30 seconds. The engine must be started within that time or the fuel solenoid will deenergize, and the switch must be toggled to reset the timer.

2. START PUSHBUTTON

Energizes the starter motor to crank the engine. With the engine "Run / Stop" switch in the "Run" position, push and hold the Start button to crank the engine; release as the engine starts. Do not press while engine is running since this can cause damage to the ring gear and/or starter motor

3. HOUR METER

The hour meter displays the total time that the engine has been running. This meter is a useful indicator for scheduling preventive maintenance.

4. FUEL LEVEL GAUGE

Displays the level of diesel fuel in the fuel tank.

The operator must watch the fuel level closely to prevent running out of fuel and possibly having to bleed the system.

5. ENGINE TEMPERATURE GAUGE

The gauge displays the engine coolant temperature.

VANTAGE® 500

LINCOLN
ELECTRIC

6. OIL PRESSURE GAUGE



The gauge displays the engine oil pressure when the engine is running.

7. ENGINE PROTECTION

The yellow engine protection light remains off with proper oil pressure and under normal operating temperatures. If the light turns on, the engine protection system will stop the engine. Check for proper oil and coolant levels and add oil and/or coolant if necessary. Check for loose or disconnected leads at the oil pressure sender located on the engine. The light will remain on when the engine has been shut down due to low oil pressure or over-temperature condition.

NOTE: This engine is equipped with an electronic governor system. The engine speed ramps up during a warm up period. The complete cycle takes approximately 3 minutes. This allows the engine cylinder temperature to build up slowly before going to full speed. This feature is bypassed if the engine is already warm. The Engine may produce "White Smoke" for a few minutes at low temperatures. Do not apply a load to the machine during the warm up period.



8. BATTERY CHARGING LIGHT



The yellow engine alternator light is off when battery charging system is functioning normally. If light turns on the alternator or the voltage regulator may not be operating correctly. The light will remain on when the engine is stopped and the run/stop switch is in the run position.

9. IDLER SWITCH

Has two positions as follows:

- A) In the "High" position,  the engine runs at the high idle speed controlled by the governor.
- B) In the "Auto"  /  position, the idler operates as follows:
- When switched from "High" to "Auto" or after starting the engine, the engine will operate at full speed for approximately 12 seconds and then go to low idle speed.
 - When the electrode touches the work or power is drawn for lights or tools (approximately 100 Watts minimum) the engine accelerates and operates at full speed.
 - When welding ceases and the AC power load is turned off, a fixed time delay of approximately 12 seconds starts.

- If the welding or AC power load is not restarted before the end of the time delay, the idler reduces the engine speed to low idle speed.
- The engine will automatically return to high idle speed when the welding load or A.C. power load is reapplied.

Idler Operational exceptions

When the WELDING TERMINALS switch is in the "Remotely Controlled" position the idler will operate as follows:

- When the triggering device (Amptrol, Arc Start Switch, etc.) is pressed the engine will accelerate and operate at full speed provided a welding load is applied within approximately 12 seconds.
 - If the triggering device remains pressed but no welding load is applied within approximately 12 seconds the engine may return to low idle speed.
 - If the triggering device is released or welding ceases the engine will return to low idle speed after approximately 12 seconds.

WELDING CONTROLS (Items 10 through 19)

10. OUTPUT CONTROL: The OUTPUT dial is used to preset the output voltage or current as displayed on the digital meters for the four welding modes. When in the CC-STICK, DOWNHILL PIPE or CV-WIRE modes and when a remote control is connected to the 6-Pin or 14-Pin Connector, the auto-sensing circuit automatically switches the OUTPUT CONTROL from control at the welder to the remote control. In the CV-WIRE mode, when the wire feeder control cable is connected to the 14-Pin Connector, the auto-sensing circuit automatically makes OUTPUT CONTROL inactive and the wire feeder voltage control active.

When in the TOUCH START TIG mode and when an Amptrol is connected to the 6-Pin Connector, the OUTPUT dial is used to set the maximum current range of the CURRENT CONTROL of the Amptrol.

11. DIGITAL OUTPUT METERS:

The digital meters allow the output voltage (CV-WIRE mode) or current (CC-STICK, DOWNHILL PIPE and TIG modes) to be set prior to welding using the OUTPUT control knob. During welding, the meters display the actual output voltage (VOLTS) and current (AMPS). A memory feature holds the display of both meters on the seven seconds after welding is stopped. This allows the operator to read the actual current and voltage just prior to when welding was ceased. While the display is being held the left-most decimal point in each display will be flashing. The accuracy of the meters is $\pm 3\%$.

12. WELD MODE SELECTOR SWITCH:

(Provides four selectable welding modes)

CV-WIRE
DOWNHILL PIPE
CC-STICK
TOUCH START TIG

13. ARC CONTROL:

The ARC CONTROL WIRE/STICK knob is active in the WIRE and STICK modes, and has different functions in these modes. This control is not active in the TIG mode.

CC-STICK mode: In this mode, the ARC CONTROL knob sets the short circuit current (arc-force) during stick welding. Increasing the number from -10(Soft) to +10(Crisp) increases the short circuit current and prevents sticking of the electrode to the plate while welding. This can also increase spatter. It is recommended that the ARC CONTROL be set to the minimum number without electrode sticking. Start with a setting at 0.

DOWNHILL PIPE mode: In this mode, the ARC CONTROL knob sets the short circuit current (arc-force) during stick welding to adjust for a soft or a more forceful digging arc (Crisp). Increasing the number from -10(Soft) to +10(Crisp) increases the short circuit current which results in a more forceful digging arc. Typically a forceful digging arc is preferred for root and hot passes. A softer arc is preferred for fill and cap passes where weld puddle control and deposition ("stacking" of iron) are key to fast travel speeds. It is recommended that the ARC CONTROL be set initially at 0.

CV-WIRE mode: In this mode, turning the ARC CONTROL knob from -10(soft) to +10(crisp) changes the arc from soft and washed-in to crisp and narrow. It acts as an inductance/pinch control. The proper setting depends on the procedure and operator preference. Start with a setting of 0.

14. WELDING TERMINALS SWITCH

In the WELD TERMINALS ON position, the output is electrically hot all the time. In the REMOTELY CONTROLLED position, the output is controlled by a wire feeder or amptrol device, and is electrically off until a remote switch is depressed.

15. WIRE FEEDER VOLTMETER SWITCH:

Matches the polarity of the wire feeder voltmeter to the polarity of the electrode.

16. 6 - PIN CONNECTOR

For attaching optional remote control equipment. Includes auto-sensing remote control circuit.

17. 14 - PIN CONNECTOR

For attaching wire feeder control cables. Includes contactor closure circuit, auto-sensing remote control circuit, and 120VAC and 42VAC power.

NOTE: When a wire feeder with a built in welding voltage control is connected to the 14-pin connector, do not connect anything to the 6-pin connector.

18. WELD OUTPUT TERMINALS + AND -

These 1/2" - 13 studs with flange nuts provide welding connection points for the electrode and work cables. For positive polarity welding the electrode cable connects to the "+" terminal and the work cable connects to this "-" terminal. For negative polarity welding the work cable connects to the "+" terminal and the electrode cable connects to this "-" terminal.

AUXILIARY POWER CONTROLS

(Items 19-23)

19. 120/240 VAC SINGLE PHASE RECEPTACLE

This is a 120/240VAC (14-50R) receptacle that provides 240VAC or can be split for 120VAC single phase auxiliary power. This receptacle has a 50 amp rating. Refer to the AUXILIARY POWER RECEPTACLES section in the installation chapter for further information about this receptacle. Also refer to the AUXILIARY POWER OPERATION section later in this chapter.

20. CIRCUIT BREAKERS

These circuit breakers provide separate overload current protection for each 120V circuit at the 240V single phase receptacle, each 120V single phase receptacle, the 240V three phase receptacle, the 120VAC in the 14-Pin connector, the 42VAC in the 14-Pin connector and battery circuit overload protection.

21. 120VAC SINGLE PHASE RECEPTACLES

These two 120VAC (5-20R) receptacles with GFCI protection provide 120VAC single phase for auxiliary power. Each receptacle has a 20 amp total rating. They are designed to protect the user from the hazards of ground faults. When the GFCI has tripped there will be no voltage available from the receptacle. Refer to the AUXILIARY POWER RECEPTACLES section in the installation chapter for further information about these receptacles. Also refer to the AUXILIARY POWER OPERATION section later in this chapter.

22. GROUND STUD

Provides a connection point for connecting the machine case to earth ground. Refer to "MACHINE GROUNDING" in the Installation chapter for proper machine grounding information.

23. 240VAC THREE PHASE RECEPTACLE

This is a 240VAC (15-50R) receptacle that provides 240VAC three phase auxiliary power. This receptacle has a 50 amp rating. **This receptacle is not present on the models covered by this manual.**

ENGINE OPERATION

STARTING THE ENGINE

1. Open the engine compartment door and check that the fuel shutoff valve is in the open position (lever to be in line with the hose).
2. Check for proper oil level and coolant level. Close engine compartment door.
3. Remove all plugs connected to the AC power receptacles.
4. Set IDLER switch to "AUTO".
5. Set the RUN/STOP switch to "RUN". Observe that the engine protection and battery charging lights are on. The engine protection light may turn off after 5 seconds or remain on until the engine is started.

6. Within 30 seconds, press and hold the engine START button until the engine starts. If the engine does not start within 30 seconds the RUN/STOP switch must be returned to the STOP position, then return to step 5.
7. Release the engine START button when the engine starts.
8. Check that the engine protection and battery charging lights are off. Investigate any indicated problem.

NOTE: The engine will go through a 3 minute warm-up cycle if cold. If the engine coolant is still warm from recent operation, the engine will go immediately to high idle and then to low idle if the idle switch is in the "AUTO" position.

COLD WEATHER STARTING

With a fully charged battery and the proper weight oil, the engine should start satisfactorily even down to about 0°F(-18°C). If the engine must be frequently started below 10°(-12°C), it may be desirable to install the optional ether start kit (K887-1). Installation and operating instructions are included in the kits.

STOPPING THE ENGINE

1. Switch the RUN/STOP switch to "STOP". This turns off the voltage supplied to the shutdown solenoid. A backup shutdown can be accomplished by shutting off the fuel valve located on the fuel line.

BREAK-IN PERIOD

The engine used to supply power for your welder is a heavy duty, industrial engine. It is designed and built for rugged use. It is very normal for any engine to use small quantities of oil until the break-in is accomplished. Check the oil level twice a day during the break-in period. In general this takes 50 to 100 hours of operation.

IMPORTANT

IN ORDER TO ACCOMPLISH THIS BREAK-IN, THE UNIT SHOULD BE SUBJECTED TO HEAVY LOADS, WITHIN THE RATING OF THE MACHINE. AVOID LONG IDLE RUNNING PERIODS.

TYPICAL FUEL CONSUMPTION

Refer to **Table B3.1** for typical fuel consumption of the VANTAGE 500 Engine for various operating scenarios.

**Table B3.1 – DEUTZ F4L2011
ENGINE FUEL CONSUMPTION**

	Deutz D1022L4i 48 HP(36kw) @1800 rpm	Running Time 25 Gal.(94.6L) (Hours)
Low Idle No Load 1475 rpm	.47 gallons/ hour (1.77 liters/hour)	53
High Idle No Load 1900 rpm	.66 gallons/hour (2.50 liters/hour)	40
DC-CC Welding 500A @40V	1.99 gallons/hour (7.53 liters/hour)	12.6
Auxiliary Power 12,000 VA	1.25 gallons/hour (4.73 liters/hour)	20.0
Auxiliary Power 20,000VA	1.76 Gal./hour (6.66L/hour)	14.2

WELDER OPERATION

DUTY CYCLE

Duty Cycle is the ratio of the uninterrupted on-load duration to 10 minutes. The total time period of one complete on-load and no-load cycle is 10 minutes. For example, in the case of a 60% duty cycle, load is applied continuously for 6 minutes followed by a no-load period of 4 minutes.

STICK WELDING MODE

The Vantage can be used with a broad range of DC stick electrodes.

The MODE switch provides two stick welding settings as follows:

CC-STICK MODE

The CC-STICK position of the MODE switch is designed for horizontal, vertical-up and overhead welding with all types of electrodes, especially low hydrogen. The OUTPUT CONTROL knob adjusts the full output range for stick welding.

The ARC CONTROL knob sets the short circuit (arc-force) current during stick welding. Increasing the number from -10 (Soft) to +10 (Crisp) increases the short circuit current and prevents sticking of the electrode to the plate while welding. This can also increase spatter. It is recommended that the ARC CONTROL be set to the minimum number without electrode sticking. Start with the knob set at 0.

DOWNHILL PIPE MODE

This slope controlled setting is intended for “out-of-position” and “down hill” pipe welding where the operator would like to control the current level by changing the arc length. The OUTPUT CONTROL knob adjusts the full output range for pipe welding.

The ARC CONTROL knob sets the short circuit current (arc-force) during stick welding to adjust for a soft or a more forceful digging arc (Crisp). Increasing the number from -10 (Soft) to +10 (Crisp) increases the short circuit current which results in a more forceful digging arc. Typically a forceful digging arc is preferred for root and hot passes. A softer arc is preferred for fill and cap passes where weld puddle control and deposition (“stacking” of iron) are key to fast travel speeds. It is recommended that the ARC CONTROL be set initially at 0.

TOUCH START TIG MODE

The Vantage can be used in a wide variety of DC TIG welding applications.

The TOUCH START TIG setting of the MODE switch is for DC TIG (Tungsten Inert Gas) welding. To initiate a weld, the OUTPUT CONTROL knob is first set to the desired current and the tungsten is touched to the work. During the time the tungsten is touching the work there is very little voltage or current and, in general, avoids tungsten contamination. Then, the tungsten is gently lifted off the work in a rocking motion, which establishes the arc.

To stop the arc, simply lift the TIG torch away from the work piece. When the arc voltage reaches approximately 30 volts, the arc will go out and the machine will automatically reset to the touch start current level. The tungsten may then be retouched to the work piece to restrike the arc. The arc may also be started and stopped with an Amptrol or Arc Start Switch.

The ARC CONTROL is not active in the TIG mode.

In general the ‘Touch Start’ feature avoids tungsten contamination without the use of a Hi-frequency unit. If the use of a high frequency generator is desired, the K930-2 TIG Module can be used with the Vantage. The settings are for reference.

The Vantage is equipped with the required R.F. bypass circuitry for the connection of high frequency generating equipment.

The Vantage and any high frequency generating equipment must be properly grounded. See the K930-2 TIG Module operating manuals for complete instructions on installation, operation, and maintenance.

When using the TIG Module, the OUTPUT control on the Vantage is used to set the maximum range of the CURRENT CONTROL on the TIG Module or an Amptrol if connected to the TIG Module.

VANTAGE® 500



TABLE B3.2 – TYPICAL CURRENT RANGES¹ FOR TUNGSTEN ELECTRODES²

Tungsten Electrode Diameter in. (mm)	DCEN (-)	DCEP (+)	Approximate Argon Gas Flow Rate C.F.H. (l/min.)		TIG TORCH Nozzle Size ^{4,5}
	1%, 2% Thoriated Tungsten	1%, 2% Thoriated Tungsten	Aluminum	Stainless Steel	
0.010 (.25)	2-15	³	3-8 (2-4)	3-8 (2-4)	#4, #5, #6
0.020 (.50)	5-20	³	5-10 (3-5)	5-10 (3-5)	
0.40 (1.0)	15-80	³	5-10 (3-5)	5-10 (3-5)	
1/16 (1.6)	70-150	10-20	5-10 (3-5)	9-13 (4-6)	#5, #6
3/32 (2.4)	150-250	15-30	13-17 (6-8)	11-15 (5-7)	#6, #7, #8
1/8 (3.2)	250-400	25-40	15-23 (7-11)	11-15 (5-7)	
5/32 (4.0)	400-500	40-55	21-25 (10-12)	13-17 (6-8)	#8, #10
3/16 (4.8)	500-750	55-80	23-27 (11-13)	18-22 (8-10)	
1/4 (6.4)	750-1000	80-125	28-32 (13-15)	23-27 (11-13)	

¹When used with argon gas. The current ranges shown must be reduced when using argon/helium or pure helium shielding gases.

²Tungsten electrodes are classified as follows by the American Welding Society (AWS):

Pure	EWP
1% Thoriated	EWTh-1
2% Thoriated	EWTh-2

Though not yet recognized by the AWS, Ceriated Tungsten is now widely accepted as a substitute for 2% Thoriated Tungsten in AC and DC applications.

³DCEP is not commonly used in these sizes.

⁴TIG torch nozzle “sizes” are in multiples of 1/16ths of an inch:

# 4 = 1/4 in. (6 mm)	# 7 = 7/16 in. (11 mm)
# 5 = 5/16 in. (8 mm)	# 8 = 1/2 in. (12.5 mm)
# 6 = 3/8 in. (10 mm)	#10 = 5/8 in. (16 mm)

⁵TIG torch nozzles are typically made from alumina ceramic. Special applications may require lava nozzles, which are less prone to breakage, but cannot withstand high temperatures and high duty cycles.

VANTAGE 500 SETTINGS WHEN USING THE K799 HI-FREQ UNIT

- Set the WELD MODE switch to the 20-250 setting (TIG).
- Set the IDLER switch to the HIGH position.
- Set the WELDING TERMINALS switch to the WELD TERMINALS ON position. This will close the solid state contactor and provide an always “hot” electrode.

NOTE: This is necessary because the K799 circuitry with respect to the #2 and #4 leads does not provide the proper signal to open and close the solid state contactor in the Vantage 500.

VANTAGE 500 SETTINGS WHEN USING A K930-[] TIG MODULE

- Set the WELD MODE switch to the 20-250 setting (TIG).
- Set the IDLER switch to the AUTO position.
- Set the WELDING TERMINALS switch to the REMOTELY CONTROLLED position. This will keep the solid state contactor open and provide a “cold” electrode until the triggering device (Amptrol or Arc Start Switch) is pressed.

VANTAGE® 500



WIRE FEED (CONSTANT VOLTAGE) WELDING

Connect a wire feeder to the Vantage 500 and set welder controls according to the instructions listed earlier in this section. See the operator's manual for the wire feeder or the "*Diagrams*" section of this manual for connecting instructions of various Lincoln wire feeders.

The Vantage 500 in the CV-WIRE position can be used with a broad range of flux cored wire (Innershield and Outershield) electrodes and solid wires for MIG welding (GMAW). Welding can be finely tuned using the ARC CONTROL.

Some recommended Innershield electrodes are: NR-311, NS-3M, NR-207, NR-203 Ni 1%, NR-204-H.

Recommended Outershield electrodes are: 0S-70, 0S-71M.

Some recommended solid wires for MIG welding are: .035 (0.9 mm), .045 (1.1 mm) and .052 (1.3 mm), L-50 and L-56, .035 (0.9 mm) and .045 (1.1 mm) Blue Max MIG 308 LS.

For any electrodes, including the above recommendations, the procedures should be kept within the rating of the machine. For additional electrode information, see Lincoln publications N-675, GS-100 and GS-210.

AUXILIARY POWER OPERATION

Start the engine and set the IDLER control switch to the desired operating mode. Full power is available regardless of the welding control settings, if no welding current is being drawn.

The auxiliary power of the Vantage consists of two 20 Amp-120VAC (5-20R) duplex receptacles and one 50 Amp-120/240 VAC (14-50R) receptacle. The 120/240VAC receptacle can be split for single phase 120 VAC operation.

The auxiliary power capacity is 12,000 watts of 60 Hz, single phase power. The auxiliary power capacity rating in watts is equivalent to volt-amperes at unity power factor. The maximum permissible current of the 240 VAC output is 50 A. The 240 VAC output can be split to provide two separate 120 VAC outputs with a maximum permissible current of 50 A per output to two separate 120 VAC branch circuits. Output voltage is within $\pm 10\%$ at all loads up to rated capacity.

NOTE: The 120/240V receptacle has two 120V outputs of different phases and cannot be paralleled.

The auxiliary power receptacles should only be used with three-wire grounded type plugs or approved double insulated tools with two wire plugs.

The current rating of any plug used with the system must be at least equal to the current capacity of the associated receptacle.

SIMULTANEOUS WELDING AND AUXILIARY POWER LOADS

It must be noted that the above auxiliary power ratings are with no welding load. Simultaneous welding and power loads are specified in **Table B3.3 or B3.4**. The permissible currents shown assume that current is being drawn from either the 120 VAC or 240 VAC supply (not both at the same time).

ARC GOUGING

For optimal performance when arc gouging, set the Vantage 500 WELD MODE switch to the CC - STICK position, and the ARC CONTROL to 10.

Set the OUTPUT knob to adjust output current to the desired level for the gouging electrode being used according to the ratings in the following table:

Electrode Diameter	Current Range (DC, electrode positive)
1/8"	30-60 Amps
5/32"	90-150 Amps
3/16"	150-200 Amps
1/4"	200-400 Amps
5/16"	250-400 Amps
3/8"	350-575 Amps*

* Maximum current setting is limited to the Vantage 500 maximum of 575 Amps.

PARALLELING

When paralleling machines in order to combine their outputs, all units must be operated in the CC - STICK mode only. To achieve this, turn the WELD MODE switch to the CC - STICK position. Operation in other modes may produce erratic outputs and large output imbalances between the units.

TABLE B3.3 Vantage 500 Duetz Simultaneous Welding and Power Loads

Welding Output at NEMA Voltage ($V = .04I + 20$)	Permissible Power Watts (Unity Power Factor)	Permissible Auxiliary Current in Amperes	
		@ 120VAC * +/- 10%	@ 240 VAC +/- 10%
0-250A/30V	12,000	100**	50
350A/34V	8,100	68**	34
400A/36V	5,600	46	23
450A/38V	2,900	24	12
500A/40V	0	0	0

* Each duplex receptacle is limited to 20 amps.

** Not to exceed 50A per 120 VAC branch circuit when splitting the 240 VAC output.

EXTENSION CORD RECOMMENDATIONS

An extension cord can be used with the auxiliary power outputs as long as it is of ample size. Table B.5 lists permissible extension cord lengths based on conductor size and auxiliary power output.

TABLE B3.4 – VANTAGE 500 EXTENSION CORD LENGTH RECOMMENDATIONS

Current (Amps)	Voltage (Volts)	Load (Watts)	Maximum Allowable Cord Length in ft. (m) for Conductor Size											
			14 AWG		12 AWG		10 AWG		8 AWG		6 AWG		4 AWG	
15	120	1800	30	(9)	40	(12)	75	(23)	125	(38)	175	(53)	300	(91)
15	240	3600	60	(18)	75	(23)	150	(46)	225	(69)	350	(107)	600	(183)
20	120	2400			30	(9)	50	(15)	88	(27)	138	(42)	225	(69)
20	240	48010			60	(18)	100	(30)	175	(53)	275	(84)	450	(137)
25	240	6000					90	(27)	150	(46)	225	(69)	250	(76)
30	240	7200					75	(23)	120	(37)	175	(53)	300	(91)
38	240	9000							100	(30)	150	(46)	250	(76)
50	240	12000									125	(38)	200	(61)

Conductor size is based on maximum 2.0% voltage drop.

Return to Section TOC

Return to Section TOC

Return to Section TOC

Return to Section TOC

Return to Master TOC

Return to Master TOC

Return to Master TOC

Return to Master TOC

VANTAGE® 500



Accessories - VANTAGE® 500 Deutz F4L2011 (Codes 11180, 11415)

Options/AccessoriesC3.2

 Optional Field Installed AccessoriesC3.2

 Plasma Cutting OptionC3.2

 TIG Welding OptionsC3.3

 High Frequency Generators for TIG ApplicationsC3.3

 Wire Feeder OptionsC3.3

Return to Master TOC

Return to Master TOC

Return to Master TOC

Return to Master TOC

OPTIONAL FIELD INSTALLED ACCESSORIES

K802N POWER PLUG KIT - Provides four 120V plugs rated at **20 amps** each and one dual voltage, full KVA plug rated at 120/240V, 50 amps. 120V plug may not be compatible with NEMA common household receptacles.

K802R POWER PLUG KIT - Provides four 120V plugs rated **15 amps** each and one dual voltage, full KVA plug rated at 120/240V, 50 amps, 120V plug is compatible with NEMA common household receptacles.

K857 25 ft. (7.5 m) or K857-1 100 ft. (30.4 m) REMOTE CONTROL - Portable control provides same dial range as the output control on the welder from a location up to the specified length from the welder. Has convenient plug for easy connection to the welder. The VANTAGE 500 CUMMINS is equipped with a 6-pin connector for connecting the remote control.

K704 ACCESSORY SET - Includes 35 feet (10 m) of electrode cable and 30 feet (9 m) of work cable, head-shield, Filter plate, work clamp and electrode holder. Cable is rated at 500 amps, 60% duty cycle.

K2641-2 FOUR WHEELED STEERABLE YARD TRAILER

For in plant and yard towing. Comes standard with a Duo-Hitch™, a 2" Ball and Lunette Eye combination hitch.

K2636-1 TRAILER - Two-wheeled trailer with optional fender and light package. For highway use, consult applicable federal, state, and local laws regarding possible additional requirements. Comes standard with a Duo-Hitch™, a 2" Ball and Lunette Eye combination hitch, a fender & a light package. **Order:**

K2636-1 Trailer

K958-1 Ball Hitch

K958-2 Lunette Eye Hitch

K2639-1 Fender & Light Kit

K2640-1 Cable Rack

K887-1 ETHER START KIT - Provides maximum cold weather starting assistance for frequent starting below 10°(-12°C). Required Ether tank is not provided with kit.

K899-1 SPARK ARRESTOR KIT - Easily mounts to standard muffler.

K1816-1 Full KVA Adapter Kit - Plugs into the 120/240V NEMA 14-50R receptacle on the case front (which accepts 4-prong plugs) and converts it to a NEMA 6-50R receptacle (which accepts 3-prong plugs) for connection to Lincoln Equipment with a NEMA 6-50P plug,

T12153-9 Full-KVA Power Plug-One dual voltage plug rated at 120/240V, 50 amps, single phase.

K2356-1 Control Panel Cover Kit-Clear plexiglass cover to protect control panel from dirt and debris, and to visually monitor machine operation. Lockable to deter vandalism.

K2340-1 Lockable Fuel Cap / Flash Arrester Kit-For use in locations where flash arrester safety is required. Lockable fuel cap prevents tampering with fuel. Green cap color provides a visual reminder to use diesel when refueling.

PLASMA CUTTING

K1581-1 Pro-cut 80 - Cuts mild steel using the 3-phase AC generator power from the engine driven welder.

NOTE: Other Linclon plasma cutters, both single phase and 3 phase can be used as long as the rating of the receptacle is not exceeded

WARNING

Pipe Thawing with an arc welder can cause fire, explosion, damage to electric wiring or to the arc welder if done improperly. The use of an arc welder for pipe thawing is not approved by the CSA, nor is it recommended or supported by Lincoln Electric.

TIG OPTIONS

K1783-9 PTA-26V TIG Torch

Air Cooled 200 amp torch (2 piece) equipped with valve for gas flow control. 25 ft. (7.6m) length.

KP509 Magnum Parts Kit for PTA-26V TIG Torch

Magnum Parts Kit provides all the torch accessories you need to start welding. Parts kit provides collets, collet bodies, a black cap, alumina nozzles and tungstens in a variety of sizes, all packaged in an easy to carry reclosable sack.

K870 Foot Amptrol®-Varies current while welding for making critical TIG welds and crater filling. Depress pedal to increase current. Depressing pedal fully achieves maximum set current. Fully raising the pedal finishes the weld and starts the after flow cycle on systems so equipped. Includes 25 ft. (7.6m) control cable.

K963-3 Hand Amptrol®-Varies current for making critical TIG welds. Fastens to the torch for convenient thumb control. Comes with a 25 ft. (7.6m) cable. (One size fits all Pro-Torch TIG Torches.)

K2347-1 Precision TIG 185 Ready-Pak

For AC TIG Welding with square wave performance use the AC generator of the Engine-Driven Welder to supply the power. Easy setup. Includes torch, foot amptrol, gas regulator and hose. Requires the K1816-1 Full KVA adapter kit.

K2350-1 Invertec® V205-T AC/DC One-Pak™ Package

For AC TIG welding with square wave performance, use the AC generator of the engine-driven welder to supply the power. Easy setup. Includes torch, parts kit, regulator and hose kit, Twist-Mate™ torch adapter, work cable with Twist-Mate end and foot Amptrol®.

HIGH FREQUENCY GENERATORS FOR TIG APPLICATIONS

The K799 Hi-Freq Unit and the K930- [] TIG Modules are suitable for use with the Vantage 500. The Vantage 500 is equipped with the required RF bypass circuitry for the connection of high frequency generating equipment. The high frequency bypass network supplied with the K799 Hi-Freq Unit does NOT need to be installed into the Vantage 500.

The Vantage 500 and any high frequency-generating equipment must be properly grounded. See the K799 Hi-Freq Unit and the K930-All TIG Module operating manuals for complete instructions on installation, operation, and maintenance.

WIRE FEEDER OPTIONS

K449 LN-25 Wire Feeder

Portable CC/CV unit for flux-cored and MIG welding. Includes Gas Solenoid & Internal Contactor.

KP653-3/32 Drive Roll and Guide Tube Kit (for LN-25)

For .068-3/32" (1.8-2.4mm) cored or solid steel wire.

K126-2 Magnum® 350 Innershield Gun (for LN-25)

For self-shielded wire with 15 ft. (4.5m) cable. For .062-3/32" (1.6-2.4mm) wire.

K1802-1 Magnum® 300 MIG Gun

For .035-.045 (0.9-1.2mm) gas shielded wire. Includes 15 ft. gun and cable assembly and connector kit.

KP653-035S Drive Roll and Guide Tube Kit (for LN-25)

For .035-.040" (0.9-1.0mm) solid steel wire.

K2613-1 LN-25 PRO PORTABLE WIRE FEEDER-The MAXTRAC® wire drive enhances performance, while the replacement case, and many other upgrade options that can be installed in less than five minutes aid in the serviceability.

KP1697-5/64 Drive Roll Kit- Includes: 2 polished U groove drive rolls, outer wire guide and inner wire guide for solid core wire. (Used on LN-25 Pro)

KP1697-068 Drive Roll Kit- Includes: 2 polished U groove drive rolls, outer wire guide and inner wire guide for solid core wire. (Used on LN-25 Pro)

KP1696-1 Drive Roll Kit- Includes: 2 V groove drive rolls and inner wire guide for Steel Wires. (Used on LN-25 Pro)

K487-25 Magnum SG Spool Gun

Hand held semiautomatic wire feeder. Requires SG Control Module and Input Cable.

K488 SG Control Module

The Interface between the power source and the spool gun. Provides control of the wire speed and gas flow. For use with a spool gun.

K691-10 Input Cable (For SG Control Module)

For Lincoln engine power sources with 14-pin MS-type connection, separate 115V NEMA receptacles and output stud connections.

OTHER WIRE FEEDERS USABLE WITH THE VANTAGE 500

- NA-3 or LT-7 Automatic Wire Feeder
- LN-742 Semi-automatic Wire Feeder
- LF-72/74 Semi-automatic Wire feeder
- LN-7 Semi-automatic Wire Feeder
- LN-8 Semi-automatic Wire Feeder
- LN-23P Semi-automatic Wire Feeder
- LN-15 Semi-automatic Wire Feeder

See the Wire Feeder Manual or the Diagrams section of this manual for connection information of the various feeders to the Vantage 500.

VANTAGE® 500



Return to Section TOC

Return to Section TOC

Return to Section TOC

Return to Section TOC

Return to Master TOC

Return to Master TOC

Return to Master TOC

Return to Master TOC

VANTAGE® 500



Maintenance - VANTAGE® 500 Deutz D2011L4i (Codes 11468)

Safety Precautions D3.2

Routine and Periodic Maintenance D3.2

 Engine Maintenance D3.2

 Change the Oil and Oil Filter D3.2

 Fuel D3.3

 Fuel Filters D3.4

 Air Filter D3.6

 Cooling System D3.7

 Cooling Blower Belt D3.7

Engine Maintenance Schedules and Parts D3.8

Welder/Generator Maintenance D3.8

 Storage D3.8

 Cleaning D3.8

 Nameplates D3.8

 Brush Removal and Replacement D3.8

 Bearings D3.8

 Receptacles D3.8

Cable Connections D3.8

Battery Maintenance D3.9

 Cleaning the Battery D3.9

 Checking Specific Gravity D3.9

 Checking Electrolyte Level D3.9

 Charging the Battery D3.9

Major Component Locations D3.10

Return to Master TOC

Return to Master TOC

Return to Master TOC

Return to Master TOC

SAFETY PRECAUTIONS

WARNING

- Have qualified personnel do all maintenance and troubleshooting work.
- Turn the engine off before working inside the machine.
- Remove covers or guards only when necessary to perform maintenance and replace them when the maintenance requiring their removal is complete.
- If covers or guards are missing from the machine, get replacements from a Lincoln Distributor.

Read the Safety Precautions in the front of this manual and in the instruction manual for the diesel engine used with your machine before working on the Vantage 500.

Keep all equipment safety guards, covers, and devices in position and in good repair. Keep your hands, hair, clothing, and tools away from the fans, and all other moving parts when starting, operating, or repairing this machine.

ROUTINE AND PERIODIC MAINTENANCE

ENGINE MAINTENANCE

DAILY

- Check the crankcase oil level.
- Refill the fuel tank to minimize moisture condensation in the tank.
- Open the water drain valve located on the bottom of the water separator element one or two turns and allow to drain into a container suitable for diesel fuel for two to three seconds. Repeat the above drainage procedure until diesel fuel is detected in the container.

WEEKLY

Blow out the machine with low pressure air periodically. In particularly dirty locations, this may be required once a week.

CAUTION

To prevent the engine from accidentally starting, disconnect the negative battery cable before servicing the engine.

See the Service Plan section of the Engine Operation Manual for a summary of maintenance intervals for the items listed below. Follow either the hourly or the calendar intervals, whichever come first. More frequent service may be required, depending on your specific application and operating conditions.

OIL: Check the oil level after every 8 hours of operation or daily. BE SURE TO MAINTAIN THE OIL LEVEL.

Change the oil the first time between 25 and 50 hours of operation. Then, under normal operating conditions, change the oil as specified in Service Plan section of the Engine Operation Manual. If the engine is operated under heavy load or in high ambient temperatures, change the oil more frequently.

CHANGE THE OIL AND FILTER

CHANGE THE OIL

Change the oil, while the engine is still warm, as follows:

1. Route the Oil Drain hose through the access hole in the frame. Drain the oil using the ball valve on the lower right side of the engine. See **Figure D3.1**.
2. When the oil is drained, close the ball valve.
3. Remove the oil fill cap and pour in approximately 9 quarts (8.5 L) of oil. Check the dipstick and add oil until the level reaches the "MAX" mark. See **Figure D3.1**. Use high quality oil viscosity grade 10W40. Consult the engine manual for oil specifications for various ambient temperatures. Always check the level with the dipstick before adding more oil. Do not overfill.
4. Reinstall the oil fill cap and the dipstick.

FIGURE D3.1 – ENGINE ASSEMBLY

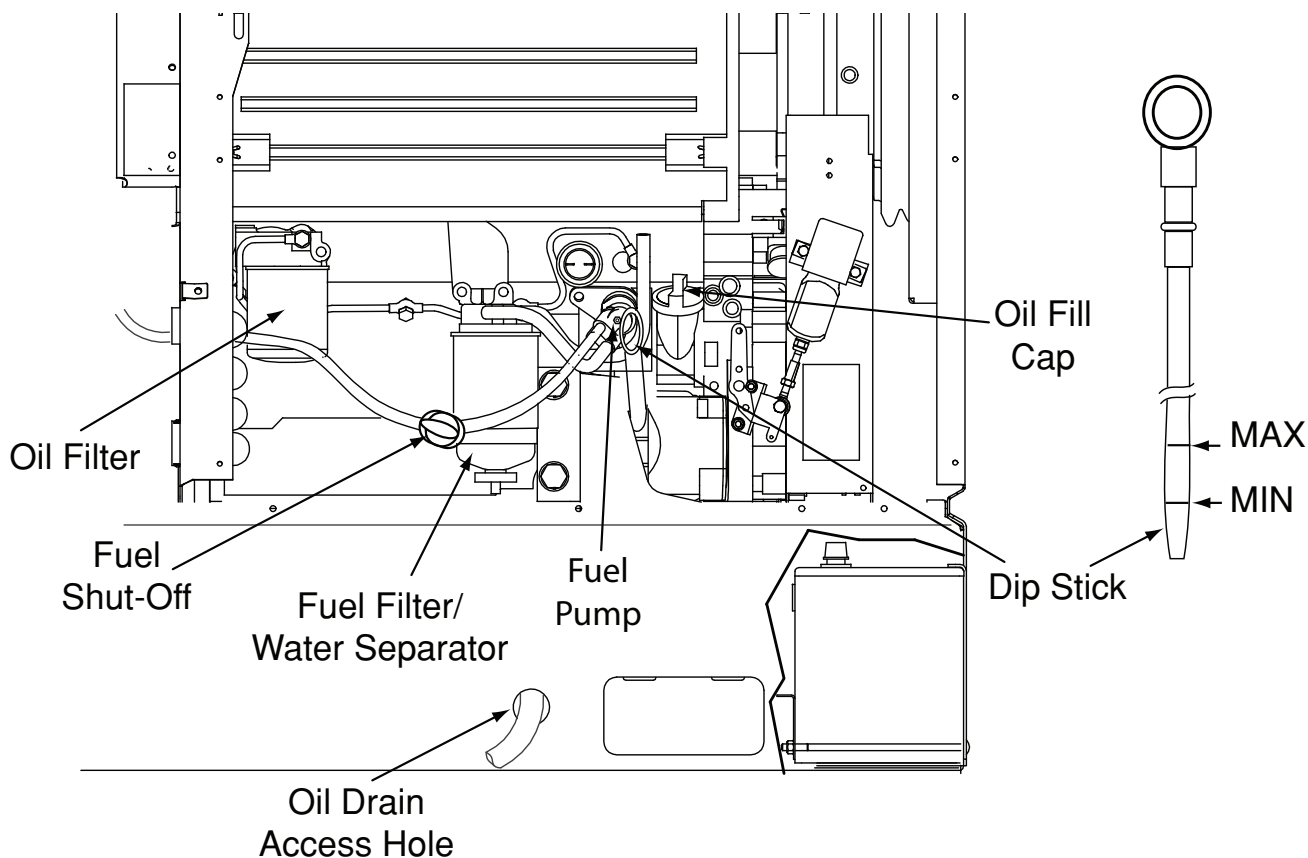

CHANGE THE OIL FILTER

Change the oil filter the first time between 25 and 50 hours of operation. Then, under normal operating conditions, change the oil filter after every 250 hours of operation. If the engine is operated under heavy load or in high ambient temperatures, change the oil filter more frequently. See Service Plan section of the Engine Operation Manual for recommended maintenance intervals. See **Table D3.1** for replacement oil filters.

Change the oil filter as follows:

1. Drain the oil from the engine and allow the oil filter to drain. See Figure D3.1.
2. Remove the old filter (spin it off) and discard it. Wipe off the filter mounting surface and adapter. See Figure D3.1.
3. Fill the new filter with fresh engine oil. Apply a thin coat of new oil to the rubber gasket on the new oil filter.
4. Spin the new filter onto the mounting adapter finger tight until the gasket is evenly seated. Then turn it down another 1/2 turn. Do not overtighten the new filter.

5. Refill the engine with the proper amount and type of oil as described in the **Change the Oil** section. Start the engine and check for leaks around the filter element. Correct any leaks (usually by retightening the filter, but only enough to stop leaks) before placing the Vantage 500 back in service.
6. If there are no leaks, stop the engine and recheck the oil level. If necessary, add oil to bring the level up to the "MAX" mark, but do not overfill. See Figure D3.1.

FUEL

At the end of each day's use, refill the fuel tank to minimize moisture condensation and dirt contamination in the fuel line. Do not overfill; leave room for the fuel to expand.

Refer to your engine operation manual for recommended grade of fuel.

FUEL FILTERS

WARNING



When working on the fuel system

- Keep naked lights away, do not smoke !
- Do not spill fuel !

The VANTAGE 500 DEUTZ is equipped with a **Fuel Filter/Water Separator** located after the lift pump and before fuel injectors. The procedure for changing the filter is as follows. See Figure D3.2

1. Close the fuel shutoff valve.
2. Clean the area around the fuel filter head. Remove the filter. Clean the gasket surface of the filter head and replace the o-ring.
3. Fill the clean filter with clean fuel, and lubricate the o-ring seal with clean lubricating oil.
4. Install the filter as specified by the filter manufacturer.

WARNING

Mechanical overtightening will distort the threads, filter element seal or filter can.

There is also a filter screen in the fuel pump that should be checked whenever the Fuel Filter/Water Separator maintenance is performed. See Figure D3.3

- Close the fuel Shut-off valve.
- Remove the hex screw (1) on the top of the fuel pump.
- Remove the cover and strainer (2) and clean the strainer with diesel fuel (replace if necessary).
- Make sure the seal (3) is in place. Replace the strainer and tighten the hex screw.
- Open the fuel valve and check for leaks.

FIGURE D3.3 - FUEL PUMP

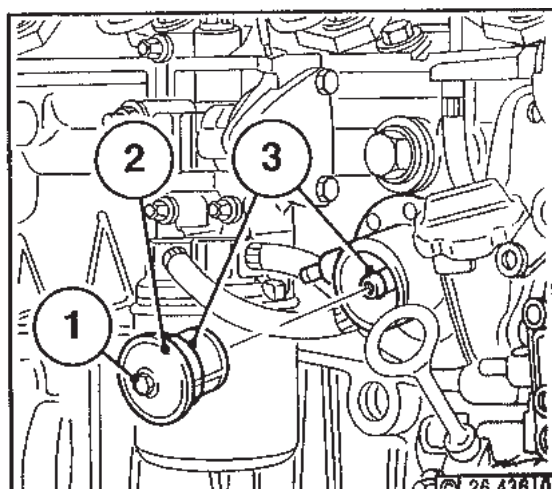
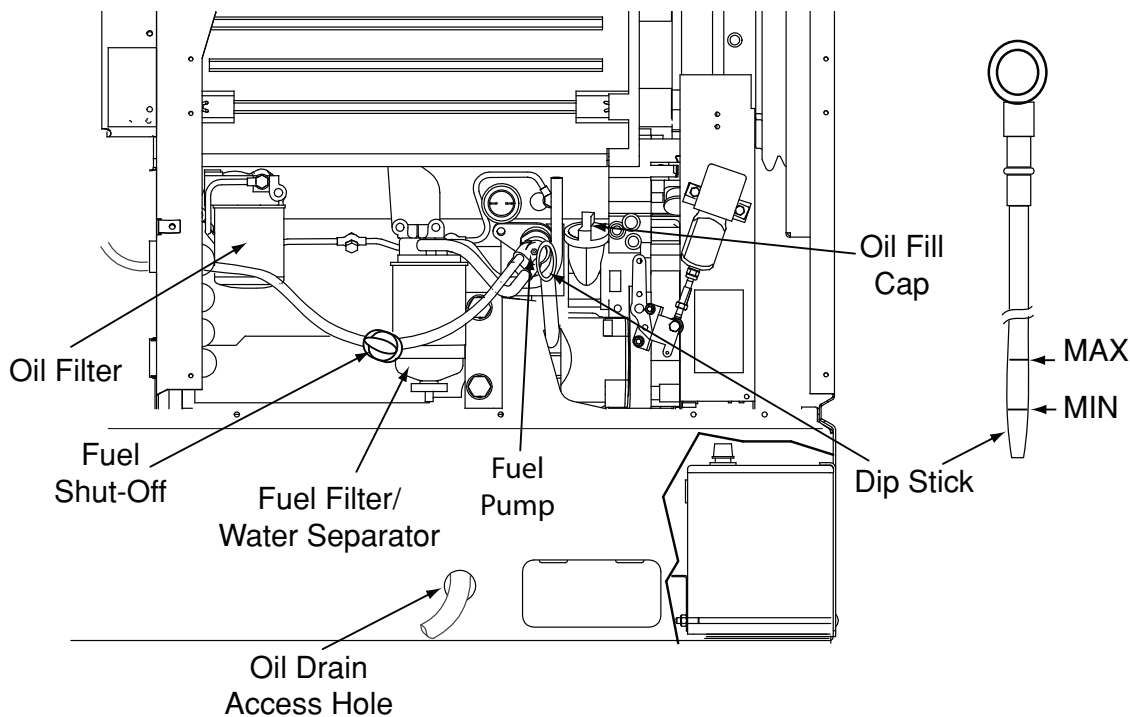

FIGURE D3.2 - ENGINE ASSEMBLY



AIR FILTER:

CAUTION

Excessive air filter restriction will result in reduced engine life.

The air filter element is a dry cartridge type. It can be cleaned and reused. However, damaged elements should not be reused. Stop engine after 100 hours of running time and clean filter element. Replace the filter if necessary. Service the air cleaner regularly according to your engine operation manual.

1. Locate the air filter canister located behind the engine door and mounted to the rear panel .
2. Remove the air filter element per the instructions on the **Maintenance Instructions** located on the door. (Also in this manual and the Operator's Manual

3. Remove loose dirt from the element with compressed air or a water hose directed from inside out.

Compressed Air: 100 psi maximum with nozzles at least one inch away from the element.

Water Hose: 40 psi maximum without nozzle.

4. Soak the element in a mild detergent solution for 15 minutes. Do not soak more than 24 hours. Swish the element around in the solution to help remove dirt.
5. Rinse elements from inside out with a gentle stream of water (less than 40 psi) to remove all suds and dirt.
6. Dry the element before reuse with warm air at less than 160°F (71°C). Do not use a light bulb to dry the element.
7. Inspect for holes and tears by looking through the element toward a bright light. Check for damaged gaskets or dented metal parts. Do not reuse damaged elements. Protect the element from dust and damage during drying and storage.
8. Reinstall the air filter element per the Maintenance Decal.

After six cleanings, replace the air filter. See the **Maintenance Instructions**. A cleaned filter will have approximately 70% of the life of a new filter element. A restricted filter element may not appear excessively dirty.

NOTE: If the entire cannister is removed or replaced, the spring clamps should be tightened to 15-20 in/lbs. See Figure D3.4

FIGURE D3.4 - AIR CLEANER

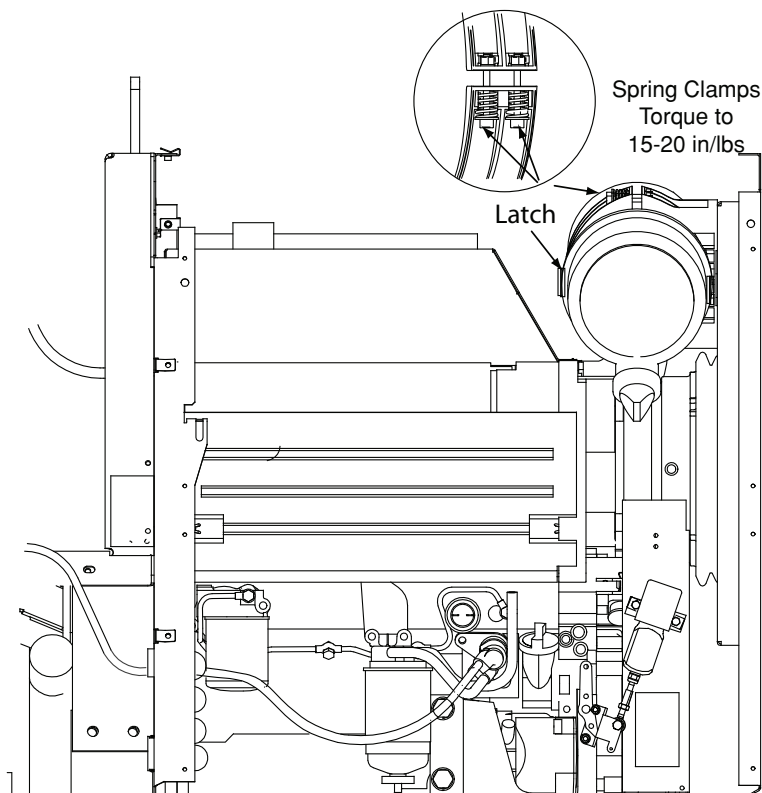

VANTAGE® 500

LINCOLN
ELECTRIC

MAINTENANCE INSTRUCTIONS

Service Instructions

Single- and Two-Stage Engine Air Cleaners

1 Remove the Filter

Rotate the filter while pulling straight out.

Unfasten or unlatch the service cover. Because the filter fits tightly over the outlet tube to create the critical seal, there will be some initial resistance, similar to breaking the seal on a jar. Gently move the end of the filter back and forth to break the seal then rotate while pulling straight out. Avoid knocking the filter against the housing.

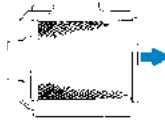

If your air cleaner has a safety filter, replace it every third primary filter change. Remove the safety filter as you would the primary filter. Make sure you cover the air cleaner outlet tube to avoid any unfiltered contaminant dropping into the engine.

2 Clean Both Surfaces of the Outlet Tube and Check the Vacuator™ Valve

Use a clean cloth to wipe the filter sealing surface and the inside of the outlet tube. Contaminant on the sealing surface could hinder an effective seal and cause leakage. Make sure that all contaminant is removed before the new filter is inserted. Dirt accidentally transferred to the inside of the outlet tube will reach the engine and cause wear. Engine manufacturers say that it takes only a few grams of dirt to "dust" an engine! Be careful not to damage the sealing area on the tube.

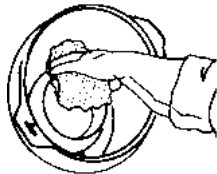

Outer edge of the outlet tube

Wipe both sides of the outlet tube clean.

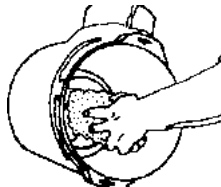

Inner edge of the outlet tube

If your air cleaner is equipped with a Vacuator Valve
Visually check and physically squeeze to make sure the valve is flexible and not inverted, damaged or plugged.

**3 Inspect the Old Filter for Leak Clues**

Visually inspect the old filter for any signs of leaks. A streak of dust on the clean side of the filter is a telltale sign. Remove any cause of leaks before installing new filter.

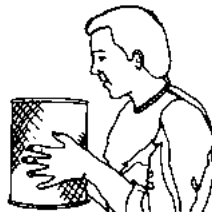
**4 Inspect the New Filter for Damage**

Inspect the new filter carefully, paying attention to the inside of the open end, which is the sealing area. NEVER install a damaged filter. A new Donaldson radial seal filter may have a dry lubricant on the seal to aid installation.

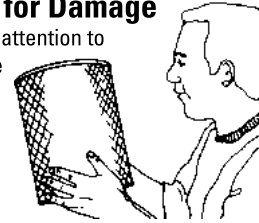
**5 Insert the New Radial Seal Filter Properly**

If you're servicing the safety filter, this should be seated into position before installing the primary filter.

Insert the new filter carefully. Seat the filter by hand, making certain it is completely into the air cleaner housing before securing the cover in place.

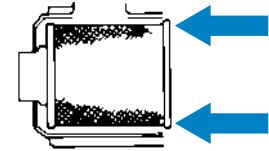

The critical sealing area will stretch slightly, adjust itself and distribute the sealing pressure evenly. To complete a tight seal, apply pressure by hand at the outer rim of the filter, not the flexible center. (Avoid pushing on the center of the urethane end cap.) No cover pressure is required to hold the seal. NEVER use the service cover to push the filter into place! Using the cover to push the filter in could cause damage to the housing, cover fasteners and will void the warranty.

If the service cover hits the filter before it is fully in place, remove the cover and push the filter (by hand) further into the air cleaner and try again. The cover should go on with no extra force.

Once the filter is in place, secure the service cover.

**Caution**

NEVER use the service cover to push the filter into place! Using the cover to push the filter in could cause damage to the housing, cover fasteners and will void the warranty.

**6 Check Connectors for Tight Fit**

Make sure that all mounting bands, clamps, bolts, and connections in the entire air cleaner system are tight. Check for holes in piping and repair if needed. Any leaks in your intake piping will send dust directly to the engine!

COOLING SYSTEM

The cooling system of the Deutz engine needs to be checked and cleaned periodically. Consult the engine Operation Manual for the proper frequency and procedures.

COOLING BLOWER BELT: The following procedure should be followed to replace the cooling blower belt:

1. Allow the machine to cool.
2. Unfasten and slide the battery holder out from the welder.
3. Disconnect the negative battery cable.
4. Remove the engine case side.
5. Loosen the air cleaner hose clamp at the engine and detach the hose.
6. Remove the engine end panel with air box and air cleaner attached for access to the engine.
7. Remove the Idler solenoid and the pulley guard.

Note the placement of the flat washer at the upper right mounting bolt of the pulley guard.

8. See Figure D3.5. Loosen the idler pulley mounting bolt and move the pulley toward the engine.
9. Remove the old cooling blower belt and install a new one.
10. Push outward on the idler pulley and adjust the cold belt tension for approximately 10-15 mm (.4-.6 in.) maximum deflection) midway between any two pulleys and tighten the bolt.
11. Reinstall the air cleaner hose, engine case side, and engine end panel. Reattach the negative battery cable. Slide in and refasten the battery holder.
12. Run the engine for 15 minutes and reset the tension per the Engine Operation Manual using a V-belt tension gauge.

FIGURE D3.5 – COOLING BLOWER BELT REPLACEMENT AND ADJUSTING

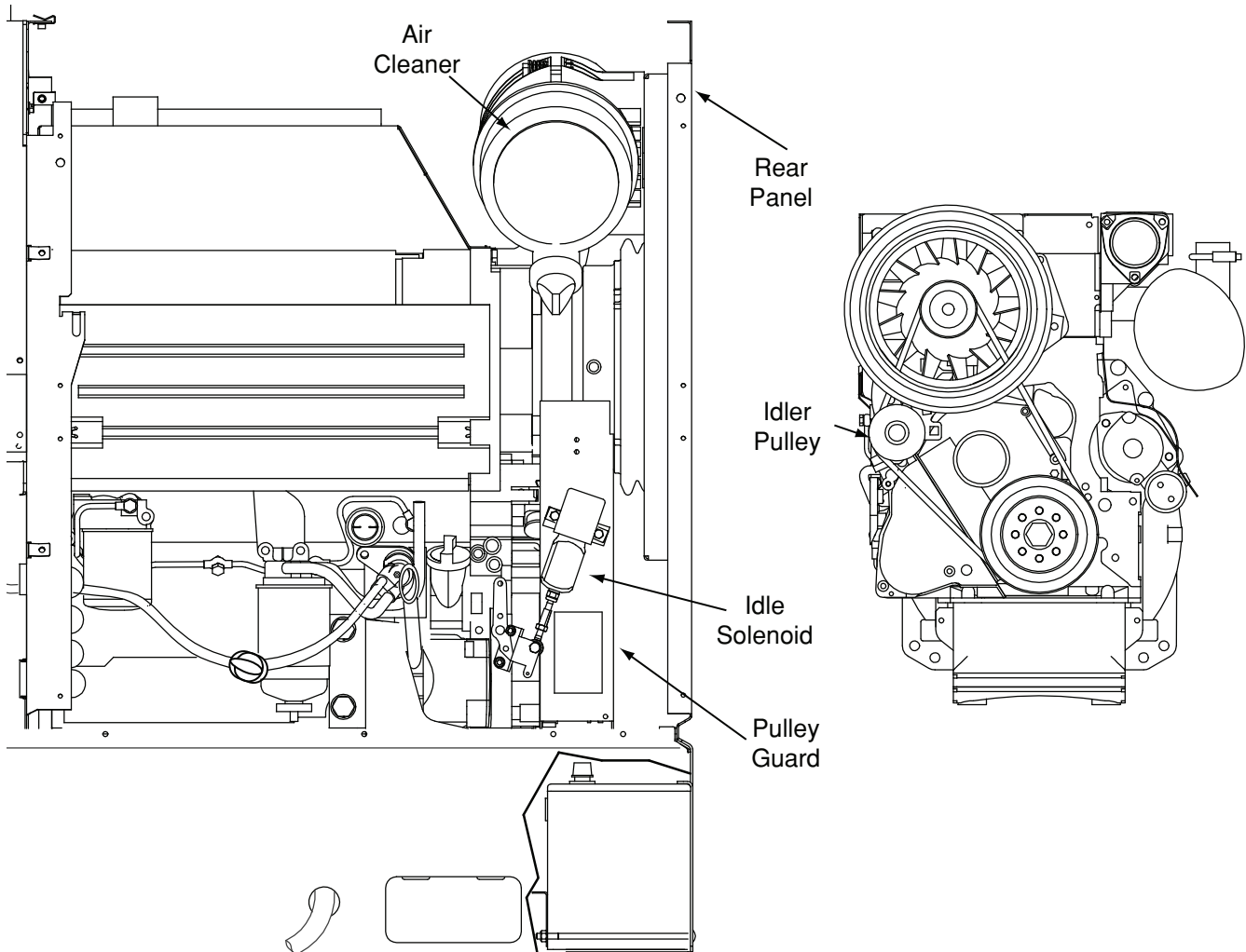

VANTAGE® 500

LINCOLN
ELECTRIC

TABLE D3.1

REPLACEMENT SERVICE ITEMS			
ITEM	MAKE	PART NUMBER	SERVICE INTERVAL
AIR CLEANER ELEMENT	DONALDSON FLEETGUARD	P822768 AF25436	CLEAN AS NEEDED, REPLACE EVERY 200 HOURS.
OIL FILTER ELEMENT	DEUTZ	01174416	SEE DEUTZ MAINTENANCE DECAL
FUEL FILTER/ WATER SEPARATOR ELEMENT	DEUTZ	01174482	
FUEL PUMP STRAINER <small>(NOT ON ALL MACHINES)</small>	DEUTZ	_____	
IN-LINE FUEL PRE-FILTER <small>(NOT ON ALL MACHINES)</small>	DEUTZ	01178753	REPLACE EVERY 500 HOURS.
COOLING BLOWER BELT	DEUTZ	01179564	INSPECT EVERY 500 HOURS
BATTERY	_____	BCI GROUP 34	INSPECT EVERY 500 HOURS

WELDER/GENERATOR MAINTENANCE

STORAGE: Store the Vantage 500 in clean, dry, protected areas.

CLEANING: Blow out the generator and controls periodically with low pressure air. Do this at least once a week in particularly dirty areas.

NAMEPLATES: Whenever routine maintenance is performed on this machine - or at least yearly - inspect all nameplates and labels for legibility. Replace those which are no longer clear. Refer to the parts list for the replacement item number.

BRUSH REMOVAL AND REPLACEMENT: It is normal for the brushes and slip rings to wear and darken slightly. Inspect the brushes when a generator overhaul is necessary.

WARNING

Do not attempt to polish slip rings while the engine is running.

BEARINGS: The Vantage 500 is equipped with double-shielded ball bearings having sufficient grease to last indefinitely under normal service. Where the welder is used constantly or in excessively dirty locations, it may be necessary to add one half ounce of grease per year. A pad of grease one inch wide, one inch long, and one inch high weighs approximately one half ounce. Overgreasing is far worse than insufficient greasing.

When greasing the bearings, keep all dirt out of the area. Wipe the fittings completely clean and use clean equipment. More bearing failures are caused by dirt introduced during greasing than from insufficient grease.

RECEPTACLES: Keep the electrical receptacles in good condition. Remove any dirt, oil, or other debris from their surfaces and holes.

CABLE CONNECTIONS: Check the welding cable connections at the weld output terminals often. Be sure that the connections are always tight.

VANTAGE® 500



BATTERY MAINTENANCE

WARNING



GASES FROM BATTERY can explode.

- Keep sparks, flame, and cigarettes away from battery.



BATTERY ACID can burn eyes and skin.

- Wear gloves and eye protection and be careful when working near a battery. Follow the instructions printed on the battery.

To prevent **EXPLOSION** when:



- **INSTALLING A NEW BATTERY** - Disconnect the negative cable from the old battery first and connect to the new battery last.

- **THE CORRECT POLARITY IS NEGATIVE GROUND** - Damage to the engine alternator and the printed circuit board can result from incorrect connection.
- **CONNECTING A BATTERY CHARGER** - Remove the battery from the welder by disconnecting the negative cable first, then the positive cable and battery clamp. When reinstalling, connect the negative cable last. Keep the area well ventilated.
- **USING A BOOSTER** - Connect the positive lead to the battery first, then connect the negative lead to the engine foot.
- To prevent **BATTERY BUCKLING**, tighten the nuts on the battery clamp until snug.

CLEANING THE BATTERY: Keep the battery clean by wiping it with a damp cloth when dirty. If the terminals appear corroded, disconnect the battery cables and wash the terminals with an ammonia solution or a solution of 1/4 pound (0.113 kg) of baking soda and 1 quart (0.946 l) of water. Be sure the battery vent plugs (if equipped) are tight so that none of the solution enters the cells.

After cleaning, flush the outside of the battery, the battery compartment, and surrounding areas with clear water. Coat the battery terminals lightly with petroleum jelly or a non-conductive grease to retard corrosion.

Keep the battery clean and dry. Moisture accumulation on the battery can lead to more rapid discharge and early battery failure.

CHECKING SPECIFIC GRAVITY: Check each battery cell with a hydrometer. A fully charged battery will have a specific gravity of 1.260. Charge the battery if the reading is below 1.215.

NOTE: Correct the specific gravity reading by adding four gravity points (0.004) for every five degrees the electrolyte temperature is above 80 degrees F (27 degrees C). Subtract four gravity points (.004) for every five degrees the electrolyte temperature is below 80 degrees F (27 degrees C).

CHECKING ELECTROLYTE LEVEL: If battery cells are low, fill them to the neck of the filler hole with distilled water and recharge. If one cell is low, check for leaks.

CHARGING THE BATTERY: The Vantage 500 is equipped with a wet charged battery. The charging current is automatically regulated when the battery is low (after starting the engine) to a trickle current when the battery is fully charged.

When you charge, jump, replace, or otherwise connect battery cables to the battery, be sure the polarity is correct. Improper polarity can damage the charging circuit. **The Vantage 500 charging system is NEGATIVE GROUND.** The positive (+) battery terminal has a red terminal cover.

If you need to charge the battery with an external charger, disconnect the negative cable first, then the positive cable before you attach the charger leads. After the battery is charged, reconnect the positive battery cable first and the negative cable last. Failure to do so can result in damage to the internal charger components.

Follow the instructions of the battery charger manufacturer for proper charger settings and charging time.

FIGURE D2.6 – MAJOR COMPONENT LOCATIONS

- | | |
|----------------------------------|------------------------|
| 1. CONTROL PANEL ASSEMBLY | 6. ENGINE ASSEMBLY |
| 2. CONTROL BOX & OUTPUT ASSEMBLY | 7. GENERATOR |
| 3. POWER MODULE ASSEMBLY | 8. SOLENOID ASSEMBLY |
| 4. BASE & LIFT BALE ASSEMBLY | 9. CASEBACK |
| 5. FUEL TANK & MOUNTING | 10. CASE TOP AND SIDES |

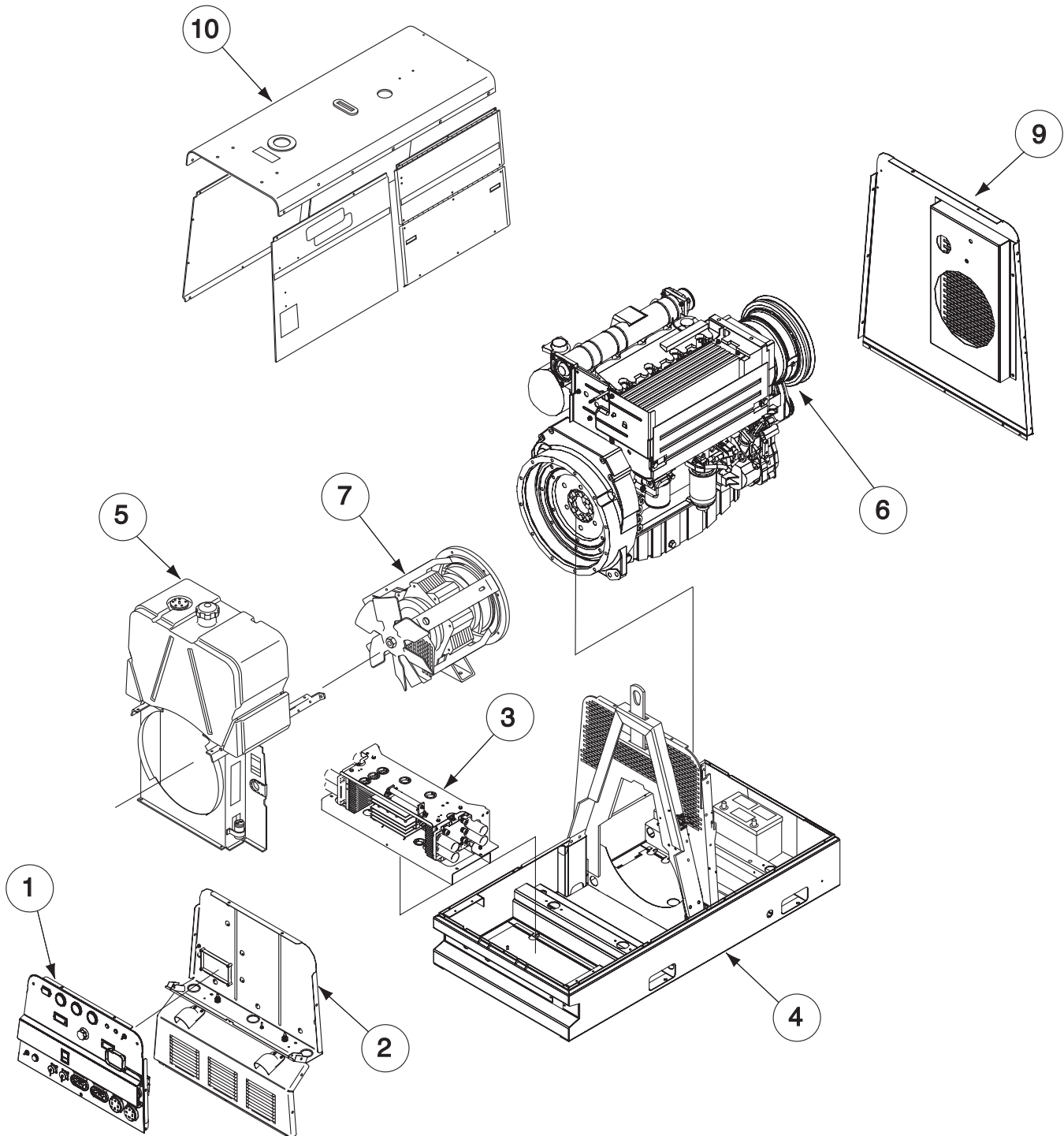

VANTAGE® 500

Installation - VANTAGE® 500 Cummins B3.3 (Code 10996)

Technical Specifications	A4.2
Safety Precautions	A4.3
Location/Ventilation	A4.3
Storing	A4.3
Stacking	A4.3
Angle of Operation	A4.3
Lifting	A4.4
High Altitude Operation	A4.4
High Temperature Operation	A4.4
Towing	A4.4
Vehicle Towing	A4.4
Pre-Operation Engine Service	A4.5
Oil	A4.5
Fuel	A4.5
Fuel Cap	A4.5
Engine Cooling System	A4.5
Battery Connection	A4.5
Muffler Outlet Pipe	A4.6
Spark Arrester	A4.6
High Frequency Generators for TIG Applications	A4.6
Electrical Connections	A4.6
Remote Control	A4.6
Welding Terminals	A4.6
Welding Output Cables	A4.7
Machine Grounding	A4.7
Auxiliary Power Receptacles	A4.7
Standby Power Connections	A4.7

TECHNICAL SPECIFICATIONS - Vantage 500 CUMMINS (K2272-1)
INPUT - DIESEL ENGINE

Make /Model	Description	Speed (RPM)	Displacement	Starting System	Capacities
Cummins B3.3 Diesel Engine	4 cylinder 56HP (42 kw) @ 1800 RPM	High Idle 1900 Low Idle 1425 Full Load 1800	199 cu. in (3.3L) Bore x Stroke 3.74" x 4.53" (95mm x 115mm)	12VDC battery & Starter	Fuel (25 US gal) 94.6L Oil: (2 US gal) 7.5L Coolant: (2.6 US gal) 11.8L

RATED OUTPUT @ 104°F(40°C) - WELDER

Duty Cycle	Welding Output	Volts at Rated Amps
100%	500 Amps (DC multi-purpose)	40 Volts
60%	550 Amps (DC multi-purpose)	36 volts
50%	575 Amps (DC multi-purpose)	35 volts

OUTPUT @ 104°F(40°C) - WELDER AND GENERATOR
Welding Range

30 - 575 Amps CC/CV
20 - 250 Amps TIG

Open Circuit Voltage

60 Max OCV @ 1900 RPM

Auxiliary Power ⁽¹⁾

120/240 VAC
12,000 WATTS, 60 Hz.

PHYSICAL DIMENSIONS

Height ⁽²⁾	Width	Depth	Weight
42.0 in (1066.8 mm)	31.5 in. (800.1mm)	63.1 in. (1603mm)	1605 lbs. (728kg) (Approx)

- Output rating in watts is equivalent to volt-amperes at unity power factor.
Output voltage is within +/- 10% at all loads up to rated capacity. When welding, available auxiliary power will be reduced.
- Top of Enclosure. Add 8.8" (223.5mm) for exhaust.

VANTAGE® 500

Read this entire installation section before you start installation.

SAFETY PRECAUTIONS



WARNING

Do not attempt to use this equipment until you have thoroughly read all operating and maintenance manuals supplied with your machine. They include important safety precautions, \detailed engine starting, operating and maintenance instructions and parts lists.

ELECTRIC SHOCK can kill.



- Do not touch electrically live parts such as output terminals or internal wiring.
- Insulate yourself from the work and ground.
- Always wear dry insulating gloves.

ENGINE EXHAUST can kill.



- Use in open, well ventilated areas or vent exhaust outside
- Do not stack anything near the engine.

MOVING PARTS can injure.



- Do not operate with doors open or guards off.
- Stop engine before servicing.
- Keep away from moving parts

Only qualified personnel should install, use or service this equipment

LOCATION / VENTILATION

The welder should be located to provide an unrestricted flow of clean, cool air to the cooling air inlets and to avoid restricting the cooling air outlets. Also, locate the welder so that the engine exhaust fumes are properly vented to an outside area.



CAUTION

DO NOT MOUNT OVER COMBUSTIBLE SURFACES

Where there is a combustible surface directly under stationary or fixed electrical equipment, that surface should be covered with a steel plate at least .06”(1.6mm) thick, which should extend not less than 5.90”(150mm) beyond the equipment on all sides.

STORING

1. Store the machine in a cool, dry place when it is not in use. Protect it from dust and dirt. Keep it where it can't be accidentally damaged from construction activities, moving vehicles, and other hazards.
2. Drain the engine oil and refill with fresh 10W30 oil. Run the engine for about five minutes to circulate oil to all the parts. See the **MAINTENANCE** section of this manual for details on changing oil.
3. Remove the battery, recharge it, and adjust the electrolyte level. Store the battery in a dry, dark place.

STACKING

Vantage 500 machines cannot be stacked.

ANGLE OF OPERATION

To achieve optimum engine performance the Vantage should be run in a level position. The maximum angle of operation for the Cummins engine is 35 degrees in all directions. If the engine is to be operated at an angle, provisions must be made for checking and maintaining the oil level at the normal (FULL) oil capacity in the crankcase. When operating the welder at an angle, the effective fuel capacity will be slightly less than the specified 25 gallons.

LIFTING

The Vantage lift bale should be used to lift the machine. The Vantage is shipped with the lift bale retracted. Before attempting to lift the Vantage, secure the lift bale in a raised position. Secure the lift bale as follows:

- Open the engine compartment door.
- Locate the two access holes on the upper middle region of the compartment wall just below the lift bale.
- Use the lifting strap to raise the lift bale to the full upright position. This will align the mounting holes on the lift bale with the access holes.
- Secure the lift bale with 2 thread forming screws. The screws are provided in the loose parts bag shipped with the machine.

WARNING

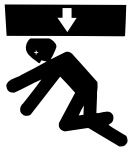

FALLING EQUIPMENT can cause injury.

- Do not lift this machine using lift bale if it is equipped with a heavy accessory such as a trailer or gas cylinder.
- Lift only with equipment of adequate lifting capacity.
- Be sure machine is stable when lifting.

HIGH ALTITUDE OPERATION

At higher altitudes, output derating may be necessary. For maximum rating, derate the welder output 4% for every 300 meters (984 ft.) above 1500 meters (4920 ft.). For output of 500A and below, derate the welder output 4% for every 300 meters (984 ft.) above 2100 meters (6888 ft.).

Contact a Cummins Service Representative for any engine adjustments that may be required.

HIGH TEMPERATURE OPERATION

At temperatures above 40°C (104°F), output voltage derating may be necessary. For maximum output current ratings, derate the welder voltage rating two volts for every 10°C (21°F) above 40°C (104°F).

TOWING

The recommended trailer for use with this equipment for road, in-plant and yard towing by a vehicle¹ is Lincoln's K953-1. If the user adapts a non-Lincoln trailer, he must assume responsibility that the method of attachment and usage does not result in a safety hazard nor damage the welding equipment. Some of the factors to be considered are as follows:

- Design capacity of the trailer vs. weight of the Lincoln equipment and likely additional attachments.
- Proper support of, and attachment to, the base of the welding equipment so that there will be no undue stress to the trailer's framework.
- Proper placement of the equipment on the trailer to insure stability side to side and front to back when being moved and when standing by itself.
- Typical conditions of use, such as travel speed, roughness of surface on which the trailer will be operated, and environmental conditions.
- Proper preventative maintenance of the trailer.
- Conformance with federal, state and local laws.¹

¹Consult applicable federal, state and local laws regarding specific requirements for use on public highways.

VEHICLE MOUNTING

WARNING

Improperly mounted concentrated loads may cause unstable vehicle handling and tires or other components to fail.

- Only transport this Equipment on serviceable vehicles which are rated and designed for such loads.
- Distribute, balance and secure loads so vehicle is stable under conditions of use.
- Do not exceed maximum rated loads for components such as suspension, axles and tires.
- Mount equipment base to metal bed or frame of vehicle.
- Follow vehicle manufacturer's instructions.

PRE-OPERATION ENGINE SERVICE

READ the engine operating and maintenance instructions supplied with this machine.

WARNING



- Keep hands away from the engine muffler or HOT engine parts.
- Stop engine and allow to cool before fueling.
- Do not smoke when fueling.
- Fill fuel tank at a moderate rate and do not over-fill.
- Wipe up spilled fuel and allow fumes to clear before starting engine.
- Keep sparks and flame away from tank.

OIL

The Vantage is shipped with the engine crankcase filled with high quality SAE 10W-30 oil (API class CD or better). Check the oil level before starting the engine. If it is not up to the full mark on the dip stick, add oil as required. Check the oil level every four hours of running time during the first 35 running hours. Refer to the engine Operator's Manual for specific oil recommendations and break-in information. The oil change interval is dependent on the quality of the oil and the operating environment. Refer to the engine Operator's Manual for the proper service and maintenance intervals.



FUEL

NOTE: USE DIESEL FUEL ONLY.

Fill the fuel tank with clean, fresh diesel fuel. The capacity of the fuel tank is approx 95 liters. See engine Operator's Manual for specific fuel recommendations. **Running out of fuel may require bleeding the fuel injection pump.** NOTE: Before starting the engine, open the fuel shutoff valve (pointer to be in line with hose).

NOTE: Before starting the engine, open the fuel shutoff valve (pointer to be in line with hose).

FUEL CAP

Remove the plastic cap covering from the fuel tank filler neck and install the fuel cap.

ENGINE COOLING SYSTEM

WARNING



- HOT COOLANT can burn skin.
- Do not remove cap if radiator is hot.

The welder is shipped with the engine and radiator filled with a 50% mixture of ethylene glycol and water. See the MAINTENANCE section and the engine Operator's Manual for more information on coolant.

WARNING

BATTERY CONNECTION



GASES FROM BATTERY can explode.

- Keep sparks, flame and cigarettes away from battery.

To prevent EXPLOSION when:

- **INSTALLING A NEW BATTERY** — disconnect negative cable from old battery first and connect to new battery last.
- **CONNECTING A BATTERY CHARGER** — remove battery from welder by disconnecting negative cable first, then positive cable and battery clamp. When reinstalling, connect negative cable last. Keep well ventilated.
- **USING A BOOSTER** — connect positive lead to battery first then connect negative lead to negative battery lead at engine foot.

WARNING



BATTERY ACID can burn eyes and skin.

- Wear gloves and eye protection and be careful when working near battery.
- Follow instructions printed on battery.

IMPORTANT: To prevent ELECTRICAL DAMAGE WHEN:

- a) Installing new batteries
- b) Using a booster

Use correct polarity — **Negative Ground.**

The Vantage is shipped with the negative battery cable disconnected. Before you operate the machine, make sure the Engine Switch is in the OFF position and attach the disconnected cable securely to the negative (-) battery terminal.

Remove the insulating cap from the negative battery terminal. Replace and tighten the negative battery cable terminal.

NOTE: This machine is furnished with a wet charged battery; if unused for several months, the battery may require a booster charge. Be sure to use the correct polarity when charging the battery.

MUFFLER OUTLET PIPE

Remove the plastic plug covering the muffler outlet tube. Using the clamp provided, secure the outlet pipe to the outlet tube with the pipe positioned to direct the exhaust in the desired direction.

SPARK ARRESTER

Some federal, state or local laws may require that gasoline or diesel engines be equipped with exhaust spark arresters when they are operated in certain locations where unarrested sparks may present a fire hazard. The standard muffler included with this welder does not qualify as a spark arrester. When required by local regulations, a suitable spark arrester must be installed and properly maintained.



CAUTION

An incorrect arrester may lead to damage to the engine or adversely affect performance.

HIGH FREQUENCY GENERATORS FOR TIG APPLICATIONS

The K799 Hi-Freq Unit (obsolete) and the K930-1 or-2 TIG Module are suitable for use with the Vantage 500. The Vantage 500 is equipped with the required R.F. bypass circuitry for the connection of high frequency generating equipment. The high frequency bypass network supplied with the K799 Hi-Freq Unit does NOT need to be installed into the Vantage 500.

The Vantage 500 and any high frequency generating equipment must be properly grounded. See the K799 Hi-Freq Unit and the K930-1 or-2 TIG Module operating manuals for complete instructions on installation, operation, and maintenance.

ELECTRICAL CONNECTIONS

REMOTE CONTROL

The Vantage 500 is equipped with a 6-pin and a 14-pin connector. The 6-pin connector is for connecting the K857 or K857-1 Remote Control (optional) or, in the case of TIG welding applications, with the foot or hand Amptrol (K870 or K963-1 respectively).

The 14-pin connector is used to directly connect a wire feeder or TIG Module (K930-1 or-2) control cable.

NOTE: When using the 14-pin connector, if the wire feeder has a built-in power source output control, do not connect anything to the 6-pin connector.

WELDING TERMINALS

The Vantage is equipped with a toggle switch for selecting "hot" welding terminals when in the "WELD TERMINALS ON" position or "cold" welding terminals when in the "WELDING TERMINALS REMOTELY CONTROLLED" position.

WELDING OUTPUT CABLES

With the engine off, route the electrode and work cables through the strain relief bracket provided on the front of the base and connect to the terminals provided. These connections should be checked periodically and tightened if necessary.

Listed in Table A4.1 are copper cable sizes recommended for the rated current and duty cycle. Lengths stipulated are the distance from the welder to work and back to the welder again. Cable sizes are increased for greater lengths primarily for the purpose of minimizing cable voltage drop.

TABLE A4.1 – COMBINED LENGTH OF ELECTRODE AND WORK CABLES

Amps @ 100% Duty Cycle	Total Combined Length of Electrode and Work Cables		
	Up to 150 ft.	150-200 ft.	200-250 ft.
500	3/0 AWG	3/0 AWG	4/0 AWG

MACHINE GROUNDING

Because this portable engine driven welder creates its own power, it is not necessary to connect its frame to an earth ground, unless the machine is connected to premises wiring (home, shop, etc.).

To prevent dangerous electric shock, other equipment powered by this engine driven welder must:

- a) be grounded to the frame of the welder using a grounded type plug,

or

- b) be double insulated.

When this welder is mounted on a truck or trailer, its frame must be securely connected to the metal frame of the vehicle. When this engine driven welder is connected to premises wiring such as that in a home or shop, its frame must be connected to the system earth ground. See further connection instructions in the section entitled **Standby Power Connections** as well as the article on grounding in the latest U.S. National Electrical Code and the local code.

In general, if the machine is to be grounded, it should be connected with a #8 or larger copper wire to a solid earth ground such as a metal water pipe going into the ground for at least ten feet and having no insulated joints, or to the metal framework of a building which has been effectively grounded. The U.S. National Electrical Code lists a number of alternate means of grounding electrical equipment. A machine grounding stud marked with the \oplus symbol is provided on the front of the welder.

AUXILIARY POWER RECEPTACLES

The auxiliary power capacity of the Vantage 500 is 12,000 watts of 60 Hz, single-phase power. The auxiliary power capacity rating in watts is equivalent to volt-amperes at unity power factor. The maximum permissible current of the 240 VAC output is 50 A. The 240 VAC output can be split to provide two separate 120 VAC outputs with a maximum permissible current of 50 A per output to two separate 120 VAC branch circuits. The output voltage is within $\pm 10\%$ at all loads up to rated capacity.

NOTE: The 120/240V receptacle has two 120V outlets of different phases and cannot be paralleled.

The Vantage has two 20A-120VAC (5-20R) duplex receptacles and one 50A-120/240 VAC (14-50R) receptacle. The 120/240 VAC receptacle can be split for single-phase 120 VAC operation. The auxiliary power receptacles should only be used with three-wire grounded type plugs or approved double insulated tools with two-wire plugs. The current rating of any plug used with the system must be at least equal to the current capacity of the associated receptacle.

STANDBY POWER CONNECTIONS

The Vantage 500 is suitable for temporary, standby or emergency power using the engine manufacturer's recommended maintenance schedule.

The Vantage 500 can be permanently installed as a standby power unit for 240 volt, three-wire, 50 amp service. Connections must be made by a licensed electrician who can determine how the 120/240 VAC power can be adapted to the particular installation and comply with all applicable electrical codes. The following information can be used as a guide by the electrician for most applications. Refer to the connection diagram shown in **Figure A4.1**.

1. Install the double-pole, double-throw switch between the power company meter and the premises disconnect.

Switch rating must be the same or greater than the customer's premises disconnect and service over current protection.

2. Take necessary steps to assure load is limited to the capacity of the Vantage by installing a 50 amp, 240 VAC double-pole circuit breaker. Maximum rated load for each leg of the 240 VAC auxiliary is 50 amperes. Loading above the rated output will reduce output voltage below the allow-

able -10% of rated voltage, which may damage appliances or other motor-driven equipment and may result in overheating of the Vantage 500 engine.

3. Install a 50 amp 120/240 VAC plug (NEMA Type 14-50) to the double-pole circuit breaker using four-conductor cable of the proper size and desired length. (The 50 amp, 120/240 VAC plug is available in the optional K802R plug kit.)
4. Plug this cable into the 50 amp 120/240 volt receptacle on the Vantage 500 case front.

Figure A4.1 Connection of the Vantage to Premises Wiring

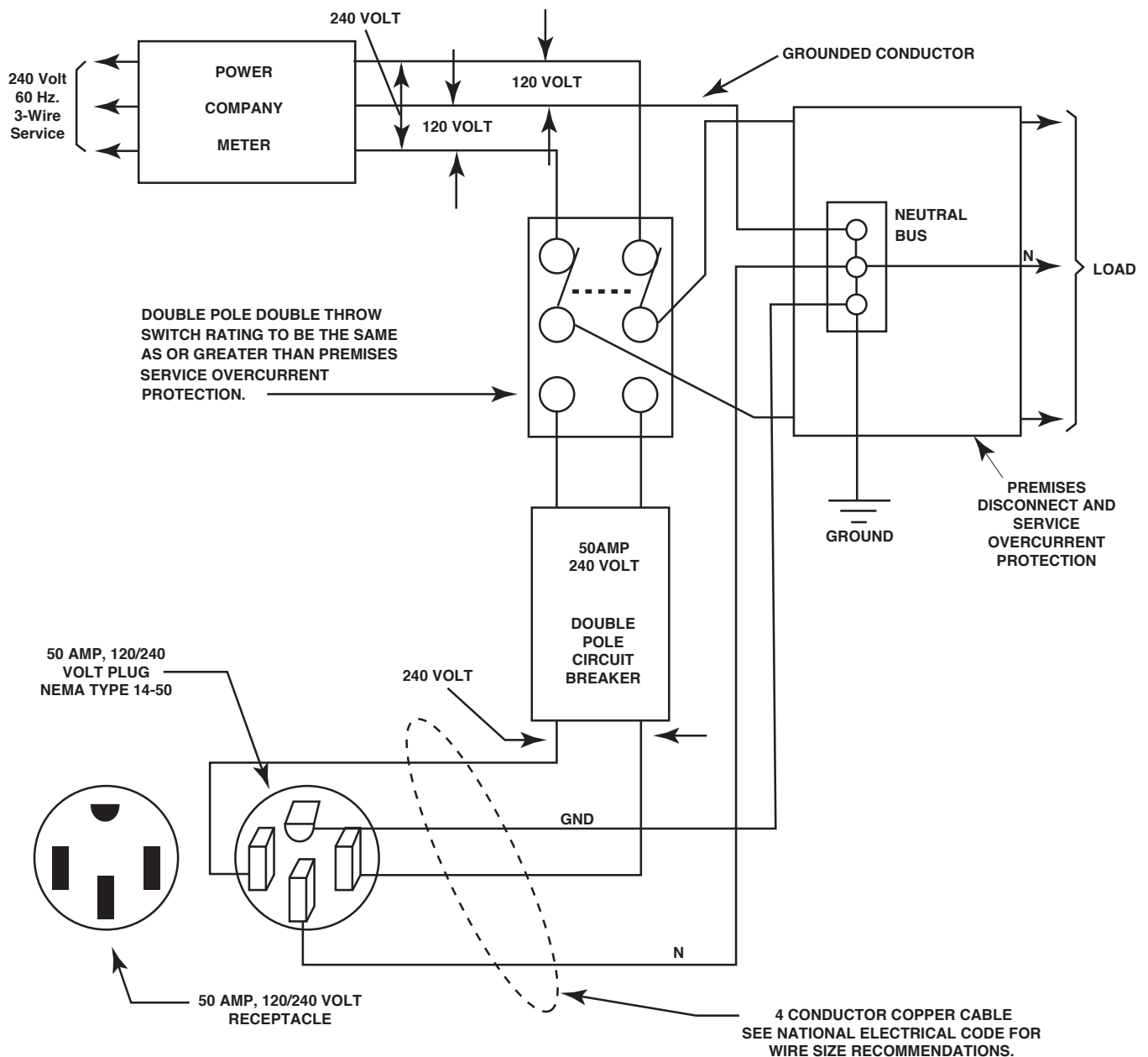

Operation - VANTAGE® 500 Cummins B3.3 (Code 10996)

Operating Instructions	B4.2
Safety Instructions	B4.2
General Description	B4.2
Recommended Applications	B4.3
Design Features and Advantages	B4.3
Controls and Settings	B4.4
Engine Controls	B4.4
Welding Controls	B4.6
Auxiliary Power Controls	B4.6
Engine Operation	B4.7
Starting the Engine	B4.7
Stopping the Engine	B4.7
Typical Fuel Consumption	B4.7
Welder Operation	B4.8
Stick Welding	B4.8
Constant Current (CC) Welding	B4.8
Pipe Welding	B4.8
TIG Welding	B4.8
Wire Feed (Constant Voltage) Welding	B4.10
Auxiliary Power Operation	B4.10
Arc Gouging	B4.10
Paralleling	B4.10
Simultaneous Welding and Auxiliary Power Loads	B4.11
Extension Cord Recommendations	B4.11

Return to Master TOC

Return to Master TOC

Return to Master TOC

Return to Master TOC

OPERATING INSTRUCTIONS

Read and understand this entire section before operating your Vantage 500.

SAFETY INSTRUCTIONS

WARNING

Do not attempt to use this equipment until you have thoroughly read all operating and maintenance manuals supplied with your machine. They include important safety precautions: detailed engine starting, operating, and maintenance instructions and parts lists.



ELECTRIC SHOCK can kill.

- Do not touch electrically live parts or electrodes with your skin or wet clothing.
- Insulate yourself from the work and ground.

- Always wear dry insulating gloves.



FUMES AND GASES CAN BE DANGEROUS.

- Keep your head out of fumes.
- Use ventilation or exhaust to remove fumes from breathing zone.

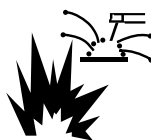

WELDING SPARKS CAN CAUSE FIRE OR EXPLOSION.

- Keep flammable material away.
- Do not weld on containers that have held combustibles.



ARC RAYS CAN BURN.

- Wear eye, ear, and body protection.



ENGINE EXHAUST can kill.

- Use in open, well ventilated areas or vent exhaust outside
- Do not stack anything near the engine.



MOVING PARTS can injure.

- Do not operate with doors open or guards off.
- Stop engine before servicing.
- Keep away from moving parts

Only qualified personnel should operate this equipment.

ADDITIONAL SAFETY PRECAUTIONS

Always operate the welder with the hinged door closed and the side panels in place, as these provide maximum protection from moving parts and insure proper cooling air flow.

GENERAL DESCRIPTION

The Vantage 500 is a diesel engine-driven welding power source. The machine uses a brush type alternating current generator for DC multi-purpose welding and for 120/240 VAC auxiliary standby power. The welding control system uses state of the art **Chopper Technology**.

The generator has a single sealed bearing for maintenance free service. The rotor is a copper wound design with two slip rings and brushes. The stator is wound entirely with heavy gauge copper wire and insulated with NEMA class F insulation material. The stator is then impregnated with three layers of high quality varnish. After the stator is assembled using tie bars, the entire assembly is covered with an environmentally protective coating. These measures insure trouble-free operation in the harshest environments.

The fuel tank is made from high density polyethylene and holds 25 gallons (94.6 liters) of diesel fuel. This will provide enough fuel to run for more than 12 hours at full load.

RECOMMENDED APPLICATIONS

WELDER

The Vantage 500 provides excellent constant current DC welding output for stick (SMAW) and TIG welding. The Vantage 500 also provides excellent constant voltage DC welding output for MIG (GMAW) and Innershield (FCAW) welding.

GENERATOR

The Vantage 500 provides smooth 120/240 VAC output for auxiliary power and emergency standby power.

DESIGN FEATURES AND ADVANTAGES

K2406-1 VANTAGE 500 DELUXE MODEL FEATURES

FOR WELDING

- Excellent DC multi-purpose welding for stick, MIG, TIG, cored wire and arc gouging applications.
- 30 to 500 amps output in five slope-controlled ranges for out-of position and pipe electrodes, one constant current output range for general purpose welding, one constant voltage range for MIG wire and cored wire welding and one 20-250 amp range for "Touch Start" TIG welding.
- 100% duty cycle at 500 amps output and 50% duty cycle at 575 amps output.
- Dual 3-digit output meters are provided (optional on K1639-1) for presetting the weld amperage or voltage and displaying the actual amperage and voltage during welding. The meters use superbrite L.E.D.'s for improved readability in full sunlight.

LOOK-BACK FEATURE: After welding has stopped, both displays will remain on for 7 seconds with the last current and voltage value displayed. During this time, the left-most decimal point in each display will be FLASHING.

- Standard remote control capability with 14-pin and 6-pin connectors for easy connection of Lincoln remote control accessories.
- An internal "Solid State" contactor allows for the selection of "hot" or "cold" output terminals with a toggle switch on the control panel.
- "Arc Control" potentiometer in Wire and Stick modes for precise adjustment of arc characteristics.
- Advanced circuitry to prevent pop-outs in the five slope modes.

FOR AUXILIARY POWER

- 12,000 watts of 120/240 VAC, 60Hz auxiliary power.
- Power for tools, 120/240 VAC lights, electric pumps and for standby emergency power.
- Drive a 5 HP motor (provided it is started under no load).
- Two 20 amp 120 VAC duplex receptacles for up to 40 amps of 120 VAC power.
- One 50 amp, 120/240 VAC dual voltage receptacle for up to 50 amps of 240 VAC, and up to 50 amps per side to separate branch circuits (not in parallel) of 120 VAC single-phase auxiliary power. Allows easy connection to premises wiring.
- Weld and AC auxiliary power at the same time (within machine total capacity).

OTHER FEATURES

- Cummins 4 cylinder/4 cycle engine. Designed for long life, easy maintenance, and excellent fuel economy.
- Engine protection system shuts the engine down for low oil pressure, high oil temperature, or a broken fan/engine alternator belt.
- Gauges for oil pressure, oil temperature, engine alternator output, and fuel level.
- Indicator lights for Engine Protection, and Battery (engine alternator low output/broken belt).
- Engine hour meter standard on all models.
- Extended range 25 gallon (94.6 l) fuel tank.
- Automatic idler reduces engine speed when not welding or drawing auxiliary power. This feature reduces fuel consumption and extends engine life.
- Compact size fits crosswise in full size pickup truck.
- Single-side engine service.
- Copper alternator windings and high temperature insulation for dependability and long life.
- New paint system on case and base for outstanding corrosion protection.

VANTAGE® 500



CONTROLS AND SETTINGS

All welder and engine controls are located on the case front. Refer to Figure B4.1 and the explanations that follow.

Figure B4.1 Case Front Panel Controls

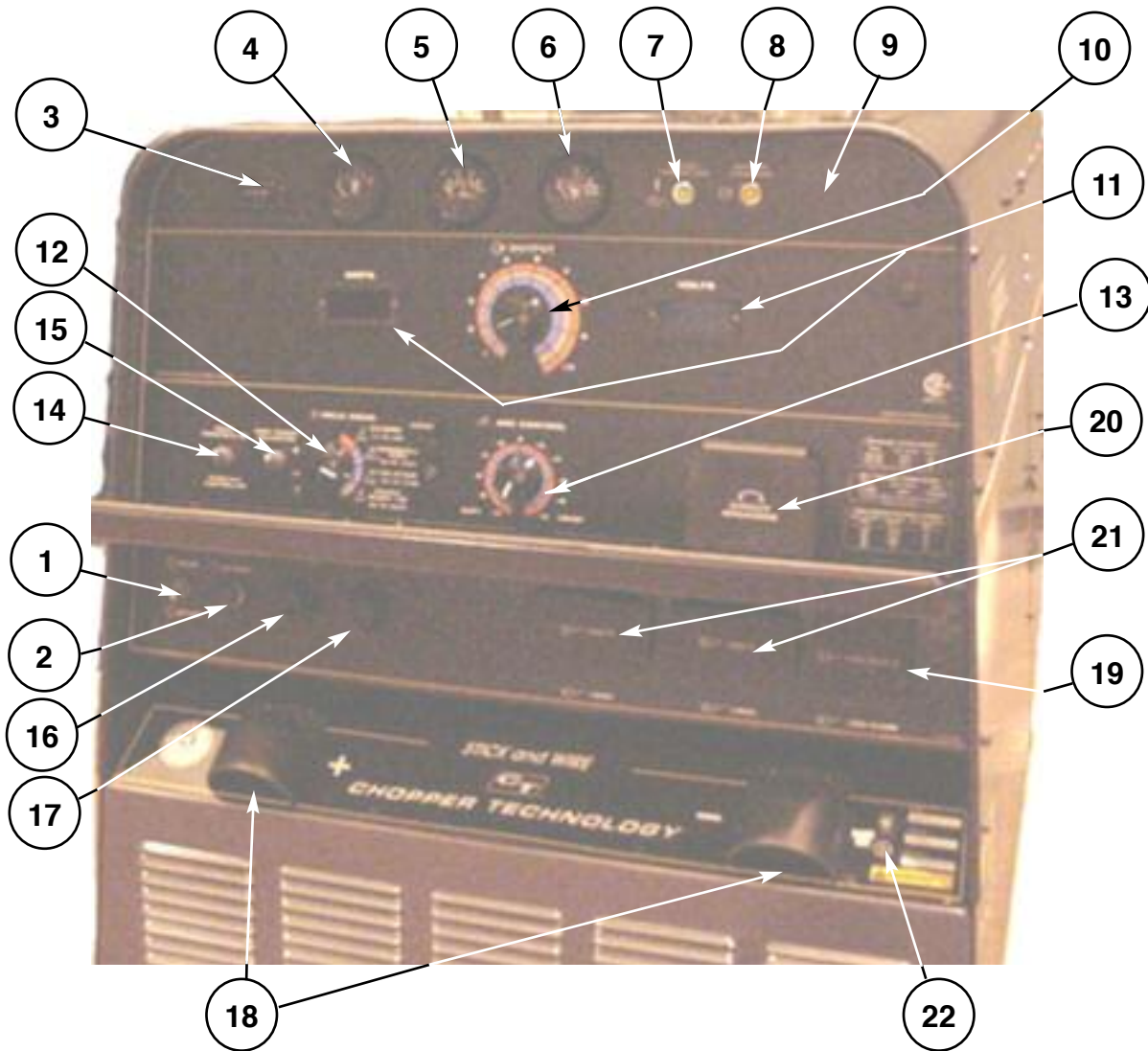

ENGINE CONTROLS (Items 1 through 9)

1. RUN STOP SWITCH

Toggling the switch to the RUN position energizes the fuel solenoid for approximately 30 seconds. The engine must be started within that time or the fuel solenoid will deenergize, and the switch must be toggled to reset the timer.

2. START PUSHBUTTON

Energizes the starter motor to crank the engine. With the engine "Run / Stop" switch in the "Run" position, push and hold the Start button to crank the engine; release as the engine starts. Do not press while engine is running since this can cause damage to the ring gear and/or starter motor

3. HOUR METER

The hour meter displays the total time that the engine has been running. This meter is a useful indicator for scheduling preventive maintenance.

4. FUEL LEVEL GAUGE

Displays the level of diesel fuel in the fuel tank.

The operator must watch the fuel level closely to prevent running out of fuel and possibly having to bleed the system.

5. ENGINE TEMPERATURE GAUGE

The gauge displays the engine coolant temperature.

VANTAGE® 500

LINCOLN
ELECTRIC

6. OIL PRESSURE GAUGE



The gauge displays the engine oil pressure when the engine is running.

7. ENGINE PROTECTION

The yellow engine protection light remains off with proper oil pressure and under normal operating temperatures. If the light turns on, the engine protection system will stop the engine. Check for proper oil and coolant levels and add oil and/or coolant if necessary. Check for loose or disconnected leads at the oil pressure sender located on the engine. The light will remain on when the engine has been shut down due to low oil pressure or over-temperature condition.

8. BATTERY CHARGING LIGHT





The yellow engine alternator light is off when battery charging system is functioning normally. If light turns on the alternator or the voltage regulator may not be operating correctly. The light will remain on when the engine is stopped and the run/stop switch is in the run position.

9. IDLER SWITCH

Has two positions as follows:

A) In the “High” position,  the engine runs at the high idle speed controlled by the governor.

B) In the “Auto”  /  position, the idler operates as follows:

- a. When switched from “High” to “Auto” or after starting the engine, the engine will operate at full speed for approximately 12 seconds and then go to low idle speed.
- b. When the electrode touches the work or power is drawn for lights or tools (approximately 100 Watts minimum) the engine accelerates and operates at full speed.
- c. When welding ceases and the AC power load is turned off, a fixed time delay of approximately 12 seconds starts.
- d. If the welding or AC power load is not restarted before the end of the time delay, the idler reduces the engine speed to low idle speed.
- e. The engine will automatically return to high idle speed when the welding load or A.C. power load is reapplied.

Idler Operational exceptions

When the WELDING TERMINALS switch is in the “Remotely Controlled” position the idler will operate as follows:

- a. When the triggering device (Amptrol, Arc Start Switch, etc.) is pressed the engine will accelerate and operate at full speed provided a welding load is applied within approximately 12 seconds.
- If the triggering device remains pressed but no welding load is applied within approximately 12 seconds the engine may return to low idle speed.
- If the triggering device is released or welding ceases the engine will return to low idle speed after approximately 12 seconds.

WELDING CONTROLS (Items 10 through 19)

10. OUTPUT CONTROL: The OUTPUT dial is used to preset the output voltage or current as displayed on the digital meters for the four welding modes. When in the CC-STICK, DOWNHILL PIPE or CV-WIRE modes and when a remote control is connected to the 6-Pin or 14-Pin Connector, the auto-sensing circuit automatically switches the OUTPUT CONTROL from control at the welder to the remote control. In the CV-WIRE mode, when the wire feeder control cable is connected to the 14-Pin Connector, the auto-sensing circuit automatically makes OUTPUT CONTROL inactive and the wire feeder voltage control active.

When in the TOUCH START TIG mode and when a Amptrol is connected to the 6-Pin Connector, the OUTPUT dial is used to set the maximum current range of the CURRENT CONTROL of the Amptrol.

11. DIGITAL OUTPUT METERS:

The digital meters allow the output voltage (CV-WIRE mode) or current (CC-STICK, DOWNHILL PIPE and TIG modes) to be set prior to welding using the OUTPUT control knob. During welding, the meters display the actual output voltage (VOLTS) and current (AMPS). A memory feature holds the display of both meters on the seven seconds after welding is stopped. This allows the operator to read the actual current and voltage just prior to when welding was ceased. While the display is being held the left-most decimal point in each display will be flashing. The accuracy of the meters is $\pm 3\%$.

12. WELD MODE SELECTOR SWITCH:

(Provides four selectable welding modes)

CV-WIRE
DOWNHILL PIPE
CC-STICK
TOUCH START TIG

13. ARC CONTROL:

The ARC CONTROL WIRE/STICK knob is active in the WIRE and STICK modes, and has different functions in these modes. This control is not active in the TIG mode.

CC-STICK mode: In this mode, the ARC CONTROL knob sets the short circuit current (arc-force) during stick welding. Increasing the number from -10(Soft) to +10(Crisp) increases the short circuit current and prevents sticking of the electrode to the plate while welding. This can also increase spatter. It is recommended that the ARC CONTROL be set to the minimum number without electrode sticking. Start with a setting at 0.

DOWNHILL PIPE mode: In this mode, the ARC CONTROL knob sets the short circuit current (arc-force) during stick welding to adjust for a soft or a more forceful digging arc (Crisp). Increasing the number from -10(Soft) to +10(Crisp) increases the short circuit current which results in a more forceful digging arc. Typically a forceful digging arc is preferred for root and hot passes. A softer arc is preferred for fill and cap passes where weld puddle control and deposition ("stacking" of iron) are key to fast travel speeds. It is recommended that the ARC CONTROL be set initially at 0.

CV-WIRE mode: In this mode, turning the ARC CONTROL knob from -10(soft) to +10(crisp) changes the arc from soft and washed-in to crisp and narrow. It acts as an inductance/pinch control. The proper setting depends on the procedure and operator preference. Start with a setting of 0.

14. WELDING TERMINALS SWITCH

In the WELD TERMINALS ON position, the output is electrically hot all the time. In the REMOTELY CONTROLLED position, the output is controlled by a wire feeder or amptrol device, and is electrically off until a remote switch is depressed.

15. WIRE FEEDER VOLTMETER SWITCH:

Matches the polarity of the wire feeder voltmeter to the polarity of the electrode.

16. 6 - PIN CONNECTOR

For attaching optional remote control equipment. Includes auto-sensing remote control circuit.

17. 14 - PIN CONNECTOR

For attaching wire feeder control cables. Includes contactor closure circuit, auto-sensing remote control circuit, and 120VAC and 42VAC power.

NOTE: When a wire feeder with a built in welding voltage control is connected to the 14-pin connector, do not connect anything to the 6-pin connector.

18. WELD OUTPUT TERMINALS + AND -

These 1/2" - 13 studs with flange nuts provide welding connection points for the electrode and work cables. For positive polarity welding the electrode cable connects to the "+" terminal and the work cable connects to this "-" terminal. For negative polarity welding the work cable connects to the "+" terminal and the electrode cable connects to this "-" terminal.

AUXILIARY POWER CONTROLS

(Items 19-22)

19. 120/240 VAC SINGLE PHASE RECEPTACLE

This is a 120/240VAC (14-50R) receptacle that provides 240VAC or can be split for 120VAC single phase auxiliary power. This receptacle has a 50 amp rating. Refer to the AUXILIARY POWER RECEPTACLES section in the installation chapter for further information about this receptacle. Also refer to the AUXILIARY POWER OPERATION section later in this chapter.

20. CIRCUIT BREAKERS

These circuit breakers provide separate overload current protection for each 120V circuit at the 240V single phase receptacle, each 120V single phase receptacle, the 240V three phase receptacle, the 120VAC in the 14-Pin connector, the 42VAC in the 14-Pin connector and battery circuit overload protection.

21. 120VAC SINGLE PHASE RECEPTACLES

These two 120VAC (5-20R) receptacles with GFCI protection provide 120VAC single phase for auxiliary power. Each receptacle has a 20 amp total rating. They are designed to protect the user from the hazards of ground faults. When the GFCI has tripped there will be no voltage available from the receptacle. Refer to the AUXILIARY POWER RECEPTACLES section in the installation chapter for further information about these receptacles. Also refer to the AUXILIARY POWER OPERATION section later in this chapter.

22. GROUND STUD

Provides a connection point for connecting the machine case to earth ground. Refer to "MACHINE GROUNDING" in the Installation chapter for proper machine grounding information.

ENGINE OPERATION

STARTING THE ENGINE

1. Open the engine compartment door and check that the fuel shutoff valve is in the open position (lever to be in line with the hose).
2. Check for proper oil level and coolant level. Close engine compartment door.
3. Remove all plugs connected to the AC power receptacles.
4. Set IDLER switch to "AUTO".
5. Set the RUN/STOP switch to "RUN". Observe that the engine protection and battery charging lights are on. The engine protection light may turn off after 5 seconds or remain on until the engine is started.
6. Within 30 seconds, press and hold the engine START button until the engine starts. If the engine does not start within 30 seconds the RUN/STOP switch must be returned to the STOP position, then return to step 5.
7. Release the engine START button when the engine starts.
8. Check that the engine protection and battery charging lights are off. Investigate any indicated problem.

NOTE: The engine will go through a 3 minute warm-up cycle if cold. If the engine coolant is still warm from recent operation, the engine will go immediately to high idle and then to low idle if the idle switch is in the "AUTO" position.

COLD WEATHER STARTING

With a fully charged battery and the proper weight oil, the engine should start satisfactorily even down to about 0°F(-18°C). If the engine must be frequently started below 10°(-12°C), it may be desirable to install the optional ether start kit (K887-1). Installation and operating instructions are included in the kits.

STOPPING THE ENGINE

1. Switch the RUN/STOP switch to "STOP". This turns off the voltage supplied to the shutdown solenoid. A backup shutdown can be accomplished by shutting off the fuel valve located on the fuel line.

TYPICAL FUEL CONSUMPTION

Refer to **Table B4.2** for typical fuel consumption of the VANTAGE 500 Engine for various operating scenarios.

Table B4.2
Cummins B3.3 Engine Fuel Consumption

	Cummins B3.3 56HP(42Kw) @1800 RPM	Running Time for 25GAL.(94.6L) (Hours)
Low Idle - no load 1425 RPM	.45 Gal./hour (1.7 Lts./hour)	55.6
High Idle - no load 1900 RPM	.81 Gal./hour (3.1 Lts./hour)	30.9
DC CC Weld Output 500 Amps @ 40 Volts	1.88 Gal./hour (7.1 Lts./hour)	13.3
Auxiliary Power 12,000 VA	1.23 Gal./hour (4.7 Lts./hour)	20.3

WELDER OPERATION

DUTY CYCLE

Duty Cycle is the ratio of the uninterrupted on-load duration to 10 minutes. The total time period of one complete on-load and no-load cycle is 10 minutes. For example, in the case of a 60% duty cycle, load is applied continuously for 6 minutes followed by a no-load period of 4 minutes.

STICK WELDING MODE

The Vantage can be used with a broad range of DC stick electrodes.

The MODE switch provides two stick welding settings as follows:

CC-STICK MODE

The CC-STICK position of the MODE switch is designed for horizontal, vertical-up and overhead welding with all types of electrodes, especially low hydrogen. The OUTPUT CONTROL knob adjusts the full output range for stick welding.

The ARC CONTROL knob sets the short circuit (arc-force) current during stick welding. Increasing the number from -10 (Soft) to +10 (Crisp) increases the short circuit current and prevents sticking of the electrode to the plate while welding. This can also increase spatter. It is recommended that the ARC CONTROL be set to the minimum number without electrode sticking. Start with the knob set at 0.

DOWNHILL PIPE MODE

This slope controlled setting is intended for “out-of-position” and “down hill” pipe welding where the operator would like to control the current level by changing the arc length. The OUTPUT CONTROL knob adjusts the full output range for pipe welding.

The ARC CONTROL knob sets the short circuit current (arc-force) during stick welding to adjust for a soft or a more forceful digging arc (Crisp). Increasing the number from -10 (Soft) to +10 (Crisp) increases the short circuit current which results in a more forceful digging arc. Typically a forceful digging arc is preferred for root and hot passes. A softer arc is preferred for fill and cap passes where weld puddle control and deposition (“stacking” of iron) are key to fast travel speeds. It is recommended that the ARC CONTROL be set initially at 0.

TOUCH START TIG MODE

The Vantage can be used in a wide variety of DC TIG welding applications.

The TOUCH START TIG setting of the MODE switch is for DC TIG (Tungsten Inert Gas) welding. To initiate a weld, the OUTPUT CONTROL knob is first set to the desired current and the tungsten is touched to the work. During the time the tungsten is touching the work there is very little voltage or current and, in general, avoids tungsten contamination. Then, the tungsten is gently lifted off the work in a rocking motion, which establishes the arc.

To stop the arc, simply lift the TIG torch away from the work piece. When the arc voltage reaches approximately 30 volts, the arc will go out and the machine will automatically reset to the touch start current level. The tungsten may then be retouched to the work piece to restrike the arc. The arc may also be started and stopped with an Amptrol or Arc Start Switch.

The ARC CONTROL is not active in the TIG mode.

In general the ‘Touch Start’ feature avoids tungsten contamination without the use of a Hi-frequency unit. If the use of a high frequency generator is desired, the K930-2 TIG Module can be used with the Vantage. The settings are for reference.

The Vantage is equipped with the required R.F. bypass circuitry for the connection of high frequency generating equipment.

The Vantage and any high frequency generating equipment must be properly grounded. See the K930-2 TIG Module operating manuals for complete instructions on installation, operation, and maintenance.

When using the TIG Module, the OUTPUT control on the Vantage is used to set the maximum range of the CURRENT CONTROL on the TIG Module or an Amptrol if connected to the TIG Module.

TABLE B4.2 – TYPICAL CURRENT RANGES¹ FOR TUNGSTEN ELECTRODES²

Tungsten Electrode Diameter in. (mm)	DCEN (-)	DCEP (+)	Approximate Argon Gas Flow Rate C.F.H. (l/min.)		TIG TORCH Nozzle Size ^{4,5}
	1%, 2% Thoriated Tungsten	1%, 2% Thoriated Tungsten	Aluminum	Stainless Steel	
0.010 (.25)	2-15	³	3-8 (2-4)	3-8 (2-4)	#4, #5, #6
0.020 (.50)	5-20	³	5-10 (3-5)	5-10 (3-5)	
0.40 (1.0)	15-80	³	5-10 (3-5)	5-10 (3-5)	
1/16 (1.6)	70-150	10-20	5-10 (3-5)	9-13 (4-6)	#5, #6
3/32 (2.4)	150-250	15-30	13-17 (6-8)	11-15 (5-7)	#6, #7, #8
1/8 (3.2)	250-400	25-40	15-23 (7-11)	11-15 (5-7)	
5/32 (4.0)	400-500	40-55	21-25 (10-12)	13-17 (6-8)	#8, #10
3/16 (4.8)	500-750	55-80	23-27 (11-13)	18-22 (8-10)	
1/4 (6.4)	750-1000	80-125	28-32 (13-15)	23-27 (11-13)	

¹When used with argon gas. The current ranges shown must be reduced when using argon/helium or pure helium shielding gases.

²Tungsten electrodes are classified as follows by the American Welding Society (AWS):

Pure	EWP
1% Thoriated	EWTh-1
2% Thoriated	EWTh-2

Though not yet recognized by the AWS, Ceriated Tungsten is now widely accepted as a substitute for 2% Thoriated Tungsten in AC and DC applications.

³DCEP is not commonly used in these sizes.

⁴TIG torch nozzle “sizes” are in multiples of 1/16ths of an inch:

# 4 = 1/4 in.	(6 mm)	# 7 = 7/16 in.	(11 mm)
# 5 = 5/16 in.	(8 mm)	# 8 = 1/2 in.	(12.5 mm)
# 6 = 3/8 in.	(10 mm)	#10 = 5/8 in.	(16 mm)

⁵TIG torch nozzles are typically made from alumina ceramic. Special applications may require lava nozzles, which are less prone to breakage, but cannot withstand high temperatures and high duty cycles.

VANTAGE 500 SETTINGS WHEN USING THE K799 HI-FREQ UNIT

- Set the WELD MODE switch to the 20-250 setting (TIG).
- Set the IDLER switch to the HIGH position.
- Set the WELDING TERMINALS switch to the WELD TERMINALS ON position. This will close the solid state contactor and provide an always “hot” electrode.

NOTE: This is necessary because the K799 circuitry with respect to the #2 and #4 leads does not provide the proper signal to open and close the solid state contactor in the Vantage 500.

VANTAGE 500 SETTINGS WHEN USING A K930-[] TIG MODULE

- Set the WELD MODE switch to the 20-250 setting (TIG).
- Set the IDLER switch to the AUTO position.
- Set the WELDING TERMINALS switch to the REMOTELY CONTROLLED position. This will keep the solid state contactor open and provide a “cold” electrode until the triggering device (Amptrol or Arc Start Switch) is pressed.

VANTAGE® 500



WIRE FEED (CONSTANT VOLTAGE) WELDING

Connect a wire feeder to the Vantage 500 and set welder controls according to the instructions listed earlier in this section. See the operator's manual for the wire feeder or the "**Diagrams**" section of this manual for connecting instructions of various Lincoln wire feeders.

The Vantage 500 in the CV-WIRE position can be used with a broad range of flux cored wire (Innershield and Outershield) electrodes and solid wires for MIG welding (GMAW). Welding can be finely tuned using the ARC CONTROL.

Some recommended Innershield electrodes are: NR-311, NS-3M, NR-207, NR-203 Ni 1%, NR-204-H.

Recommended Outershield electrodes are: 0S-70, 0S-71M.

Some recommended solid wires for MIG welding are: .035 (0.9 mm), .045 (1.1 mm) and .052 (1.3 mm), L-50 and L-56, .035 (0.9 mm) and .045 (1.1 mm) Blue Max MIG 308 LS.

For any electrodes, including the above recommendations, the procedures should be kept within the rating of the machine. For additional electrode information, see Lincoln publications N-675, GS-100 and GS-210.

AUXILIARY POWER OPERATION

Start the engine and set the IDLER control switch to the desired operating mode. Full power is available regardless of the welding control settings, if no welding current is being drawn.

The auxiliary power of the Vantage consists of two 20 Amp-120VAC (5-20R) duplex receptacles and one 50 Amp-120/240 VAC (14-50R) receptacle. The 120/240VAC receptacle can be split for single phase 120 VAC operation.

The auxiliary power capacity is 12,000 watts of 60 Hz, single phase power. The auxiliary power capacity rating in watts is equivalent to volt-amperes at unity power factor. The maximum permissible current of the 240 VAC output is 50 A. The 240 VAC output can be split to provide two separate 120 VAC outputs with a maximum permissible current of 50 A per output to two separate 120 VAC branch circuits. Output voltage is within $\pm 10\%$ at all loads up to rated capacity.

NOTE: The 120/240V receptacle has two 120V outputs of different phases and cannot be paralleled.

The auxiliary power receptacles should only be used with three-wire grounded type plugs or approved double insulated tools with two wire plugs.

The current rating of any plug used with the system must be at least equal to the current capacity of the associated receptacle.

SIMULTANEOUS WELDING AND AUXILIARY POWER LOADS

It must be noted that the above auxiliary power ratings are with no welding load. Simultaneous welding and power loads are specified in **Table B3.3 or B3.4**. The permissible currents shown assume that current is being drawn from either the 120 VAC or 240 VAC supply (not both at the same time).

ARC GOUGING

For optimal performance when arc gouging, set the Vantage 500 WELD MODE switch to the CC - STICK position, and the ARC CONTROL to 10.

Set the OUTPUT knob to adjust output current to the desired level for the gouging electrode being used according to the ratings in the following table:

Electrode Diameter	Current Range (DC, electrode positive)
1/8"	30-60 Amps
5/32"	90-150 Amps
3/16"	150-200 Amps
1/4"	200-400 Amps
5/16"	250-400 Amps
3/8"	350-575 Amps*

* Maximum current setting is limited to the Vantage 500 maximum of 575 Amps.

PARALLELING

When paralleling machines in order to combine their outputs, all units must be operated in the CC - STICK mode only. To achieve this, turn the WELD MODE switch to the CC - STICK position. Operation in other modes may produce erratic outputs and large output imbalances between the units.

TABLE B3.3 Vantage 500 Duetz Simultaneous Welding and Power Loads

Welding Output at NEMA Voltage ($V = .04I + 20$)	Permissible Power Watts (Unity Power Factor)	Permissible Auxiliary Current in Amperes	
		@ 120VAC * +/- 10%	@ 240 VAC +/- 10%
0-250A/30V	12,000	100**	50
350A/34V	8,100	68**	34
400A/36V	5,600	46	23
450A/38V	2,900	24	12
500A/40V	0	0	0

* Each duplex receptacle is limited to 20 amps.

** Not to exceed 50A per 120 VAC branch circuit when splitting the 240 VAC output.

EXTENSION CORD RECOMMENDATIONS

An extension cord can be used with the auxiliary power outputs as long as it is of ample size. Table B.5 lists permissible extension cord lengths based on conductor size and auxiliary power output.

TABLE B3.4 – VANTAGE 500 EXTENSION CORD LENGTH RECOMMENDATIONS

Current (Amps)	Voltage (Volts)	Load (Watts)	Maximum Allowable Cord Length in ft. (m) for Conductor Size											
			14 AWG		12 AWG		10 AWG		8 AWG		6 AWG		4 AWG	
15	120	1800	30	(9)	40	(12)	75	(23)	125	(38)	175	(53)	300	(91)
15	240	3600	60	(18)	75	(23)	150	(46)	225	(69)	350	(107)	600	(183)
20	120	2400			30	(9)	50	(15)	88	(27)	138	(42)	225	(69)
20	240	48010			60	(18)	100	(30)	175	(53)	275	(84)	450	(137)
25	240	6000					90	(27)	150	(46)	225	(69)	250	(76)
30	240	7200					75	(23)	120	(37)	175	(53)	300	(91)
38	240	9000							100	(30)	150	(46)	250	(76)
50	240	12000									125	(38)	200	(61)

Conductor size is based on maximum 2.0% voltage drop.

Return to Section TOC

Return to Section TOC

Return to Section TOC

Return to Section TOC

Return to Master TOC

Return to Master TOC

Return to Master TOC

Return to Master TOC

VANTAGE® 500



Accessories - VANTAGE® 500 Cummins B3.3 (Code 10996)

Options/AccessoriesC4.1

 Optional Field Installed AccessoriesC4.2

 Plasma Cutting OptionC4.2

 TIG Welding OptionsC4.3

 High Frequency Generators for TIG ApplicationsC4.3

 Wire Feeder OptionsC4.3

Return to Master TOC

Return to Master TOC

Return to Master TOC

Return to Master TOC

OPTIONAL FIELD INSTALLED ACCESSORIES

K802N POWER PLUG KIT - Provides four 120V plugs rated at **20 amps** each and one dual voltage, full KVA plug rated at 120/240V, 50 amps. 120V plug may not be compatible with NEMA common household receptacles.

K802R POWER PLUG KIT - Provides four 120V plugs rated **15 amps** each and one dual voltage, full KVA plug rated at 120/240V, 50 amps, 120V plug is compatible with NEMA common household receptacles.

K857 25 ft. (7.5 m) or K857-1 100 ft. (30.4 m) REMOTE CONTROL - Portable control provides same dial range as the output control on the welder from a location up to the specified length from the welder. Has convenient plug for easy connection to the welder. The VANTAGE 500 CUMMINS is equipped with a 6-pin connector for connecting the remote control.

K704 ACCESSORY SET - Includes 35 feet (10 m) of electrode cable and 30 feet (9 m) of work cable, head-shield, Filter plate, work clamp and electrode holder. Cable is rated at 500 amps, 60% duty cycle.

K2641-2 FOUR WHEELED STEERABLE YARD TRAILER

For in plant and yard towing. Comes standard with a Duo-Hitch™, a 2" Ball and Lunette Eye combination hitch.

K2636-1 TRAILER - Two-wheeled trailer with optional fender and light package. For highway use, consult applicable federal, state, and local laws regarding possible additional requirements. Comes standard with a Duo-Hitch™, a 2" Ball and Lunette Eye combination hitch, a fender & a light package. **Order:**

K2636-1 Trailer

K958-1 Ball Hitch

K958-2 Lunette Eye Hitch

K2639-1 Fender & Light Kit

K2640-1 Cable Rack

K887-1 ETHER START KIT - Provides maximum cold weather starting assistance for frequent starting below 10°(-12°C). Required Ether tank is not provided with kit.

K899-1 SPARK ARRESTOR KIT - Easily mounts to standard muffler.

K949-1 Oil Drain Kit - includes ball valve, hose and clamp.

K1816-1 Full KVA Adapter Kit - Plugs into the 120/240V NEMA 14-50R receptacle on the case front (which accepts 4-prong plugs) and converts it to a NEMA 6-50R receptacle (which accepts 3-prong plugs) for connection to Lincoln Equipment with a NEMA 6-50P plug,

K1858-1 Service Indicator Kit - Provides a GO / NO-GO visual indication of air cleaner element useful service life. Filter service based on restriction readings allows the longest life possible from the filter and best engine protection. (Cannot be used with K887-1 Ether Start Kit at the same time.)

T12153-9 Full-KVA Power Plug-One dual voltage plug rated at 120/240V, 50 amps, single phase.

K2356-1 Control Panel Cover Kit-Clear plexiglass cover to protect control panel from dirt and debris, and to visually monitor machine operation. Lockable to deter vandalism.

K2340-1 Lockable Fuel Cap / Flash Arrester Kit-For use in locations where flash arrester safety is required. Lockable fuel cap prevents tampering with fuel. Green cap color provides a visual reminder to use diesel when refueling.

PLASMA CUTTING

K1581-1 Pro-cut 80 - Cuts mild steel using the 3-phase AC generator power from the engine driven welder.

NOTE: Other Linclon plasma cutters, both single phase and 3 phase can be used as long as the rating of the receptacle is not exceeded

WARNING

Pipe Thawing with an arc welder can cause fire, explosion, damage to electric wiring or to the arc welder if done improperly. The use of an arc welder for pipe thawing is not approved by the CSA, nor is it recommended or supported by Lincoln Electric.

VANTAGE® 500



TIG OPTIONS

K1783-9 PTA-26V TIG Torch

Air Cooled 200 amp torch (2 piece) equipped with valve for gas flow control. 25 ft. (7.6m) length.

KP509 Magnum Parts Kit for PTA-26V TIG Torch

Magnum Parts Kit provides all the torch accessories you need to start welding. Parts kit provides collets, collet bodies, a black cap, alumina nozzles and tungstens in a variety of sizes, all packaged in an easy to carry reclosable sack.

K870 Foot Amptrol®-Varies current while welding for making critical TIG welds and crater filling. Depress pedal to increase current. Depressing pedal fully achieves maximum set current. Fully raising the pedal finishes the weld and starts the after flow cycle on systems so equipped. Includes 25 ft. (7.6m) control cable.

K963-3 Hand Amptrol®-Varies current for making critical TIG welds. Fastens to the torch for convenient thumb control. Comes with a 25 ft. (7.6m) cable. (One size fits all Pro-Torch TIG Torches.)

K2347-1 Precision TIG 185 Ready-Pak

For AC TIG Welding with square wave performance use the AC generator of the Engine-Driven Welder to supply the power. Easy setup. Includes torch, foot amptrol, gas regulator and hose. Requires the K1816-1 Full KVA adapter kit.

K2350-1 Invertec® V205-T AC/DC One-Pak™ Package

For AC TIG welding with square wave performance, use the AC generator of the engine-driven welder to supply the power. Easy setup. Includes torch, parts kit, regulator and hose kit, Twist-Mate™ torch adapter, work cable with Twist-Mate end and foot Amptrol®.

HIGH FREQUENCY GENERATORS FOR TIG APPLICATIONS

The K799 Hi-Freq Unit and the K930- [] TIG Modules are suitable for use with the Vantage 500. The Vantage 500 is equipped with the required RF bypass circuitry for the connection of high frequency generating equipment. The high frequency bypass network supplied with the K799 Hi-Freq Unit does NOT need to be installed into the Vantage 500.

The Vantage 500 and any high frequency-generating equipment must be properly grounded. See the K799 Hi-Freq Unit and the K930-All TIG Module operating manuals for complete instructions on installation, operation, and maintenance.

WIRE FEEDER OPTIONS

K449 LN-25 Wire Feeder

Portable CC/CV unit for flux-cored and MIG welding. Includes Gas Solenoid & Internal Contactor.

K126-2 Magnum® 350 Innershield Gun (for LN-25)

For self-shielded wire with 15 ft. (4.5m) cable. For .062-3/32" (1.6-2.4mm) wire.

KP653-3/32 Drive Roll and Guide Tube Kit (for LN-25)
For .068-3/32" (1.8-2.4mm) cored or solid steel wire.

K1802-1 Magnum® 300 MIG Gun

For .035-.045 (0.9-1.2mm) gas shielded wire. Includes 15 ft. gun and cable assembly and connector kit.

KP653-035S Drive Roll and Guide Tube Kit (for LN-25)

For .035-.040" (0.9-1.0mm) solid steel wire.

K2613-1 LN-25 PRO PORTABLE WIRE FEEDER-The MAXTRAC® wire drive enhances performance, while the replacement case, and many other upgrade options that can be installed in less than five minutes aid in the serviceability.

KP1697-5/64 Drive Roll Kit- Includes: 2 polished U groove drive rolls, outer wire guide and inner wire guide for solid core wire. (Used on LN-25 Pro)

KP1697-068 Drive Roll Kit- Includes: 2 polished U groove drive rolls, outer wire guide and inner wire guide for solid core wire. (Used on LN-25 Pro)

KP1696-1 Drive Roll Kit- Includes: 2 V groove drive rolls and inner wire guide for Steel Wires. (Used on LN-25 Pro)

K487-25 Magnum SG Spool Gun

Hand held semiautomatic wire feeder. Requires SG Control Module and Input Cable.

K488 SG Control Module

The Interface between the power source and the spool gun. Provides control of the wire speed and gas flow. For use with a spool gun.

K691-10 Input Cable (For SG Control Module)

For Lincoln engine power sources with 14-pin MS-type connection, separate 115V NEMA receptacles and output stud connections.

OTHER WIRE FEEDERS USABLE WITH THE VANTAGE 500

- NA-3 or LT-7 Automatic Wire Feeder
- LN-742 Semi-automatic Wire Feeder
- LF-72/74 Semi-automatic Wire feeder
- LN-7 Semi-automatic Wire Feeder
- LN-8 Semi-automatic Wire Feeder
- LN-23P Semi-automatic Wire Feeder
- LN-15 Semi-automatic Wire Feeder

See the Wire Feeder Manual or the Diagrams section of this manual for connection information of the various feeders to the Vantage 500.

VANTAGE® 500



Return to Section TOC

Return to Section TOC

Return to Section TOC

Return to Section TOC

Return to Master TOC

Return to Master TOC

Return to Master TOC

Return to Master TOC

VANTAGE® 500



Maintenance - VANTAGE® 500 Cummins B3.3 (Code 10996)

Safety PrecautionsD4.2

Routine and Periodic MaintenanceD4.2

 Engine MaintenanceD4.2

 Change the Oil and Oil FilterD4.2

 FuelD4.3

 Cooling SystemD4.3

 Fuel FiltersD4.4

 Air FilterD4.5

Engine Maintenance Schedules and PartsD4.7

Welder/Generator MaintenanceD4.7

 StorageD4.7

 CleaningD4.7

 NameplatesD4.7

 Brush Removal and ReplacementD4.7

 BearingsD4.7

 ReceptaclesD4.7

 Cable ConnectionsD4.7

Battery MaintenanceD4.8

 Cleaning the BatteryD4.8

 Checking Specific GravityD4.8

 Checking Electrolyte LevelD4.8

 Charging the BatteryD4.8

Major Component LocationsD4.9

Return to Master TOC

Return to Master TOC

Return to Master TOC

Return to Master TOC

SAFETY PRECAUTIONS

WARNING

- Have qualified personnel do all maintenance and troubleshooting work.
- Turn the engine off before working inside the machine.
- Remove covers or guards only when necessary to perform maintenance and replace them when the maintenance requiring their removal is complete.
- If covers or guards are missing from the machine, get replacements from a Lincoln Distributor.

Read the Safety Precautions in the front of this manual and in the instruction manual for the diesel engine used with your machine before working on the Vantage 500.

Keep all equipment safety guards, covers, and devices in position and in good repair. Keep your hands, hair, clothing, and tools away from the fans, and all other moving parts when starting, operating, or repairing this machine.

ROUTINE AND PERIODIC MAINTENANCE

ENGINE MAINTENANCE

DAILY

- Check the crankcase oil level.
- Refill the fuel tank to minimize moisture condensation in the tank.
- Open the water drain valve located on the bottom of the water separator element one or two turns and allow to drain into a container suitable for diesel fuel for two to three seconds. Repeat the above drainage procedure until diesel fuel is detected in the container.
- Check the coolant level.

WEEKLY

Blow out the machine with low pressure air periodically. In particularly dirty locations, this may be required once a week.



CAUTION

To prevent the engine from accidentally starting, disconnect the negative battery cable before servicing the engine.

See the Service Plan section of the Engine Operation Manual for a summary of maintenance intervals for the items listed below. Follow either the hourly or the calendar intervals, whichever come first. More frequent service may be required, depending on your specific application and operating conditions.

OIL: Check the oil level after every 8 hours of operation or daily. BE SURE TO MAINTAIN THE OIL LEVEL.

Change the oil the first time between 25 and 50 hours of operation. Then, under normal operating conditions, change the oil as specified in Service Plan section of the Engine Operation Manual. If the engine is operated under heavy load or in high ambient temperatures, change the oil more frequently.

CHANGE THE OIL AND FILTER

CHANGE THE OIL: Change the oil, while the engine is still warm, as follows:

- Route the Oil Drain hose through the access hole in the frame. Drain the oil using the ball valve on the lower right side of the engine. See **Figure D4.1**.
- When the oil is drained, close the ball valve.
- Remove the oil fill cap and pour in approximately 7.5 quarts (8 L) of oil. Check the dipstick and add oil until the level reaches the “H” mark. See **Figure D4.1**. Use high quality oil viscosity grade 10W40. Consult the engine manual for oil specifications for various ambient temperatures. Always check the level with the dipstick before adding more oil. Do not overfill.
- Reinstall the oil fill cap and the dipstick.

CHANGE THE OIL FILTER: Change the oil filter the first time between 25 and 50 hours of operation. Then, under normal operating conditions, change the oil filter after every 250 hours of operation. If the engine is operated under heavy load or in high ambient temperatures, change the oil filter more frequently. See Service Plan section of the Engine Operation Manual for recommended maintenance intervals. See **Table D4.1** for replacement oil filters.

Change the oil filter as follows:

- Drain the oil from the engine and allow the oil filter to drain. See **Figure D4.1**.
- Remove the old filter (spin it off) and discard it. Wipe off the filter mounting surface and adapter. See **Figure D4.1**.

FIGURE D4.1 – ENGINE ASSEMBLY

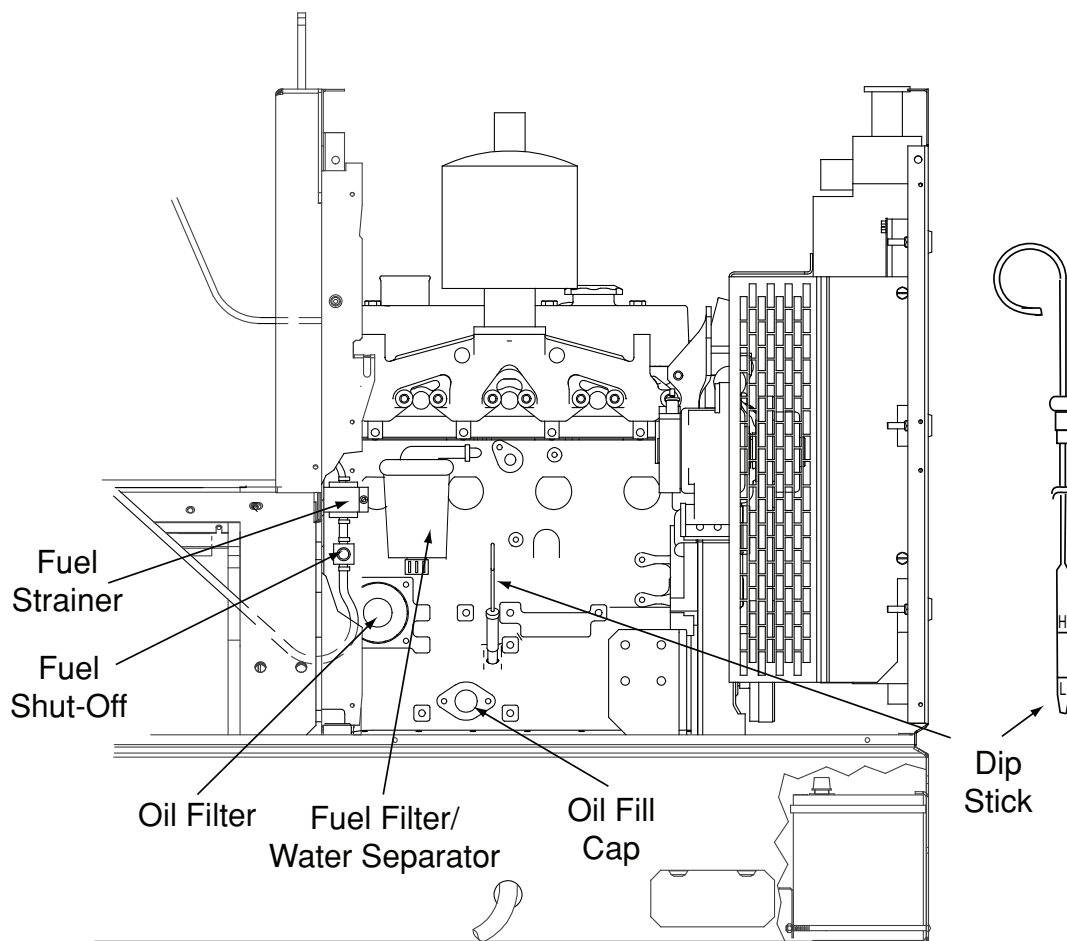

3. Apply a thin coat of new oil to the rubber gasket on the new oil filter.
4. Spin the new filter onto the mounting adapter finger tight until the gasket is evenly seated. Then turn it down another 1/2 turn. Do not overtighten the new filter.
5. Refill the engine with the proper amount and type of oil as described in the **Change the Oil** section. Start the engine and check for leaks around the filter element. Correct any leaks (usually by retightening the filter, but only enough to stop leaks) before placing the Vantage 500 back in service.
6. If there are no leaks, stop the engine and recheck the oil level. If necessary, add oil to bring the level up to the "MAX" mark, but do not overfill. See Figure D4.1.

FUEL: At the end of each day's use, refill the fuel tank to minimize moisture condensation and dirt contamination in the fuel line. Do not overfill; leave room for the fuel to expand.

Refer to your engine operation manual for recommended grade of fuel.

COOLING SYSTEM

WARNING

To avoid scalding, do not loosen or remove the radiator cap while the engine is hot.

The VANTAGE 500 Cummins is equipped with a pressurized radiator. Keep the radiator cap tight to avoid loss of coolant. Clean and flush the coolant system periodically to prevent clogging the passages and overheating the engine. See the Engine Manual for maintenance schedule.

If the coolant level is low, refill with a mixture of 50% water and 50% ethylene-glycol based antifreeze. See the Engine Manual for more information.

DRIVE BELT

Periodically check the Drive Belt tension and inspect the belt for cracks or other damage. See the Engine Manual for tension adjustment and/or belt replacement.

VANTAGE® 500



FUEL FILTERS

⚠ WARNING**When working on the fuel system**

- **Keep naked lights away, do not smoke !**
- **Do not spill fuel !**

The VANTAGE 500 Cummins is equipped with a **Fuel Filter/Water Separator** located after the lift pump and before fuel injectors. The procedure for changing the filter is as follows. See Figure D4.2

1. Close the fuel shutoff valve.
2. Clean the area around the fuel filter head. Remove the filter. Clean the gasket surface of the filter head and replace the o-ring.
3. Fill the clean filter with clean fuel, and lubricate the o-ring seal with clean lubricating oil.
4. Install the filter as specified by the filter manufacturer.
5. Open the fuel valve and check for leaks.

⚠ WARNING

Mechanical overtightening will distort the threads, filter element seal or filter can.

There is also a Fuel Strainer mounted just above the shut-off valve. See Figure D4.2. It is designed to prevent larger particle from entering the fuel system. There is no maintenance possible. If fuel flow seems restricted, replace the fuel strainer.

FIGURE D4.2 - ENGINE ASSEMBLY

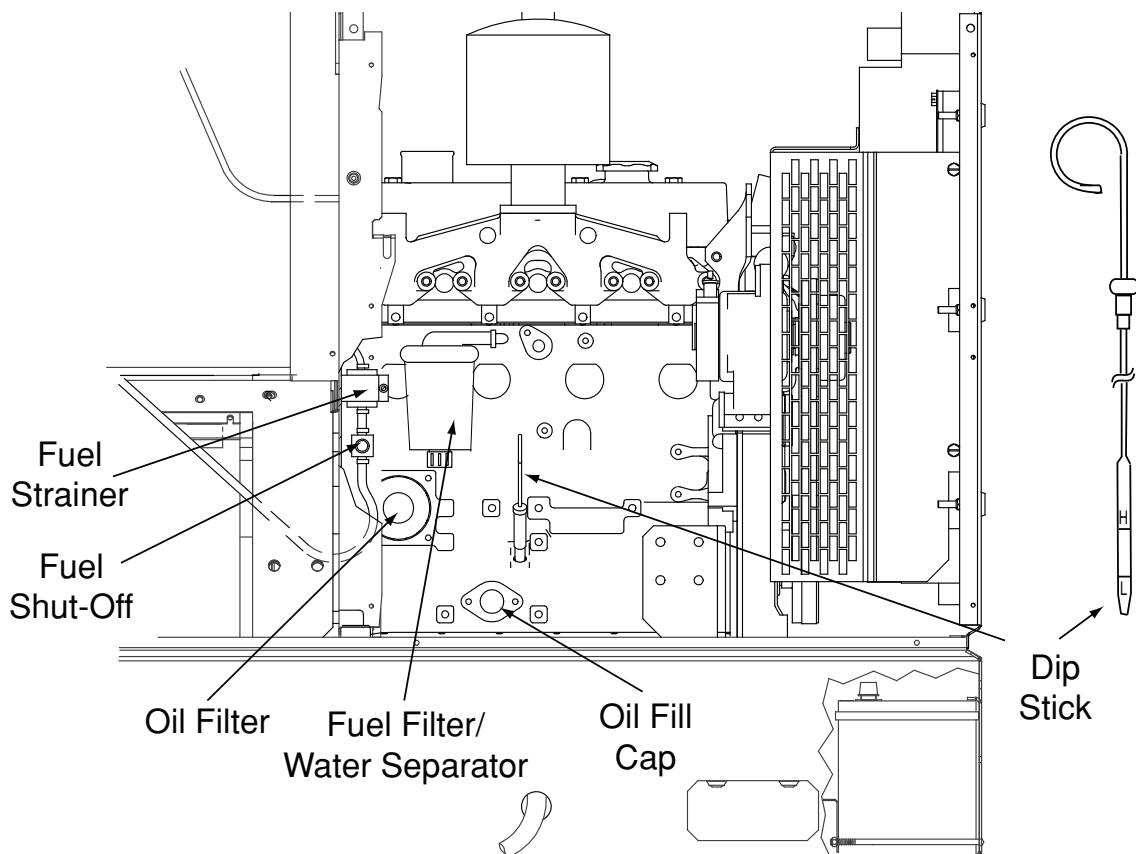

VANTAGE® 500

LINCOLN
ELECTRIC

AIR FILTER

CAUTION

Excessive air filter restriction will result in reduced engine life.

The air filter element is a dry cartridge type. It can be cleaned and reused. However, damaged elements should not be reused. Stop engine after 100 hours of running time and clean filter element. Replace the filter if necessary. Service the air cleaner regularly according to your engine operation manual.

1. Locate the air filter canister located behind the engine door and mounted to the roof .
2. Remove the air filter element per the instructions on the **Maintenance Instructions** located on the door. (Also in this manual and the Operator's Manual
3. Remove loose dirt from the element with compressed air or a water hose directed from inside out.

Compressed Air: 100 psi maximum with nozzles at least one inch away from the element.

Water Hose: 40 psi maximum without nozzle.

4. Soak the element in a mild detergent solution for 15 minutes. Do not soak more than 24 hours. Swish the element around in the solution to help remove dirt.
5. Rinse elements from inside out with a gentle stream of water (less than 40 psi) to remove all suds and dirt.
6. Dry the element before reuse with warm air at less than 160°F (71°C). Do not use a light bulb to dry the element.
7. Inspect for holes and tears by looking through the element toward a bright light. Check for damaged gaskets or dented metal parts. Do not reuse damaged elements. Protect the element from dust and damage during drying and storage.
8. Reinstall the air filter element per the Maintenance Decal.

After six cleanings, replace the air filter. See the **Maintenance Instructions**. A cleaned filter will have approximately 70% of the life of a new filter element. A restricted filter element may not appear excessively dirty.

NOTE: If the entire canister is removed or replaced, the spring clamps should be tightened to 15-20 in/lbs. See Figure D4.3

FIGURE D4.3 - AIR CLEANER

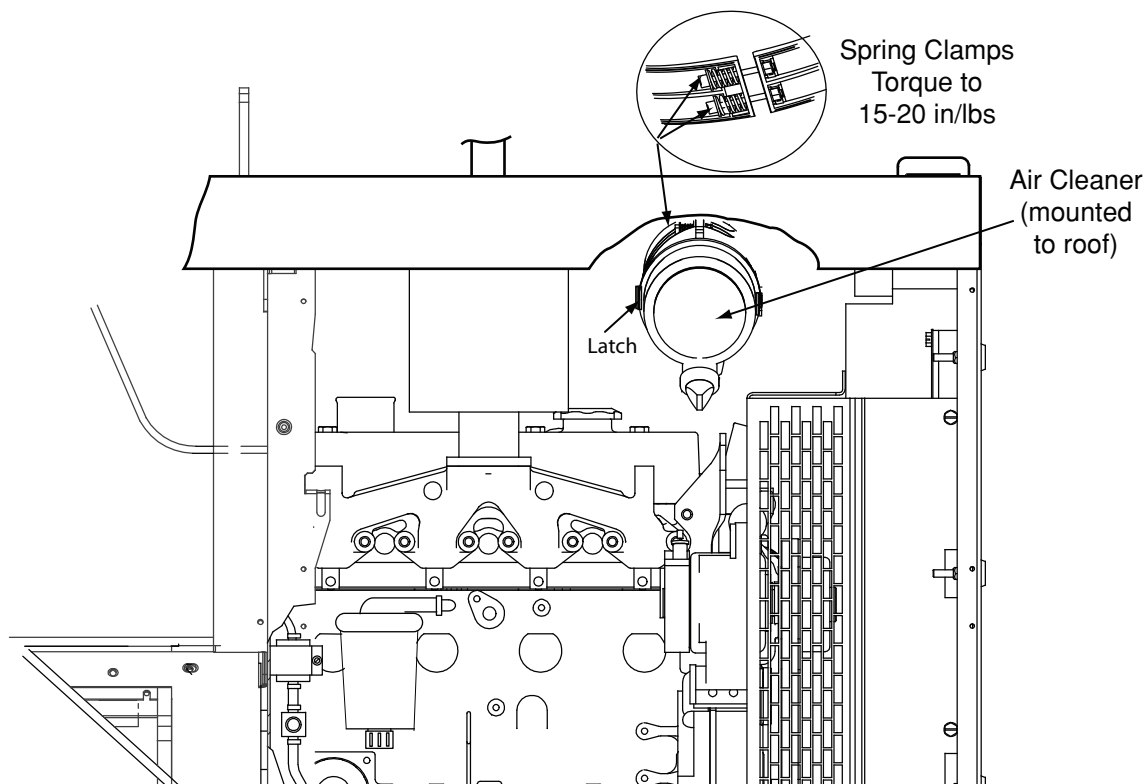

VANTAGE® 500

LINCOLN
ELECTRIC

MAINTENANCE INSTRUCTIONS

Service Instructions

Single- and Two-Stage Engine Air Cleaners

1 Remove the Filter



Rotate the filter while pulling straight out.

Unfasten or unlatch the service cover. Because the filter fits tightly over the outlet tube to create the critical seal, there will be some initial resistance, similar to breaking the seal on a jar. Gently move the end of the filter back and forth to break the seal then rotate while pulling straight out. Avoid knocking the filter against the housing.

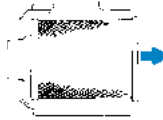

If your air cleaner has a safety filter, replace it every third primary filter change. Remove the safety filter as you would the primary filter. Make sure you cover the air cleaner outlet tube to avoid any unfiltered contaminant dropping into the engine.

2 Clean Both Surfaces of the Outlet Tube and Check the Vacuator™ Valve

Use a clean cloth to wipe the filter sealing surface and the inside of the outlet tube. Contaminant on the sealing surface could hinder an effective seal and cause leakage. Make sure that all contaminant is removed before the new filter is inserted. Dirt accidentally transferred to the inside of the outlet tube will reach the engine and cause wear. Engine manufacturers say that it takes only a few grams of dirt to "dust" an engine! Be careful not to damage the sealing area on the tube.

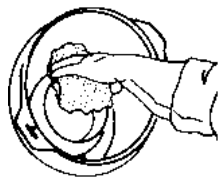

Outer edge of the outlet tube

Wipe both sides of the outlet tube clean.

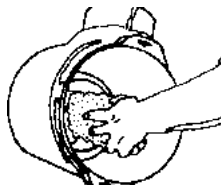

Inner edge of the outlet tube

If your air cleaner is equipped with a Vacuator Valve
Visually check and physically squeeze to make sure the valve is flexible and not inverted, damaged or plugged.



3 Inspect the Old Filter for Leak Clues

Visually inspect the old filter for any signs of leaks. A streak of dust on the clean side of the filter is a telltale sign. Remove any cause of leaks before installing new filter.

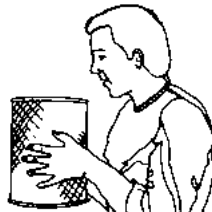

4 Inspect the New Filter for Damage

Inspect the new filter carefully, paying attention to the inside of the open end, which is the sealing area. NEVER install a damaged filter. A new Donaldson radial seal filter may have a dry lubricant on the seal to aid installation.

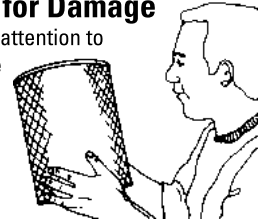

5 Insert the New Radial Seal Filter Properly

If you're servicing the safety filter, this should be seated into position before installing the primary filter.

Insert the new filter carefully. Seat the filter by hand, making certain it is completely into the air cleaner housing before securing the cover in place.

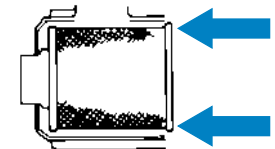

The critical sealing area will stretch slightly, adjust itself and distribute the sealing pressure evenly. To complete a tight seal, apply pressure by hand at the outer rim of the filter, not the flexible center. (Avoid pushing on the center of the urethane end cap.) No cover pressure is required to hold the seal. NEVER use the service cover to push the filter into place! Using the cover to push the filter in could cause damage to the housing, cover fasteners and will void the warranty.

If the service cover hits the filter before it is fully in place, remove the cover and push the filter (by hand) further into the air cleaner and try again. The cover should go on with no extra force.

Once the filter is in place, secure the service cover.



Caution

NEVER use the service cover to push the filter into place! Using the cover to push the filter in could cause damage to the housing, cover fasteners and will void the warranty.



6 Check Connectors for Tight Fit

Make sure that all mounting bands, clamps, bolts, and connections in the entire air cleaner system are tight. Check for holes in piping and repair if needed. Any leaks in your intake piping will send dust directly to the engine!

TABLE D4.1

Cummins B3.3 Engine Maintenance Components

ITEM	MAKE	PART NUMBER	SERVICE INTERVAL
Air Cleaner Element	Donaldson AC Fleetguard	P181052 A302C AF437K	Replace every 200 hours. (Replace more often when used in dusty and / or high ambient temperature conditions)
Oil Filer	Cummins Fleetguard	C6002112110 LF3855	Replace every 750 hours or 12 months, whichever is less.
Fan Belt	Cummins	C0412021748	Inspect every 1000 hours or 12 months, whichever is less.
Fuel Strainer	Cummins Fleetguard	3826094 FF5079	Inspect and replace monthly, as required. Replace annually.
Fuel Filter / Water Separator	Cummins Fleetguard	C6003112130 FS19594	Replace every 500 hours or 6 months, whichever is less.
Battery	-----	BCI GROUP 34	Inspect every 500 hours
Engine Oil Change	See Manual	-----	Change every 750 hours or 3 months, whichever is less. Check daily.

WELDER/GENERATOR MAINTENANCE

STORAGE: Store the Vantage 500 in clean, dry, protected areas.

CLEANING: Blow out the generator and controls periodically with low pressure air. Do this at least once a week in particularly dirty areas.

NAMEPLATES: Whenever routine maintenance is performed on this machine - or at least yearly - inspect all nameplates and labels for legibility. Replace those which are no longer clear. Refer to the parts list for the replacement item number.

BRUSH REMOVAL AND REPLACEMENT: It is normal for the brushes and slip rings to wear and darken slightly. Inspect the brushes when a generator overhaul is necessary.

WARNING

Do not attempt to polish slip rings while the engine is running.

BEARINGS: The Vantage 500 is equipped with double-shielded ball bearings having sufficient grease to last indefinitely under normal service. Where the welder is used constantly or in excessively dirty locations, it may be necessary to add one half ounce of grease per year. A pad of grease one inch wide, one inch long, and one inch high weighs approximately one half ounce. Over-greasing is far worse than insufficient greasing.

When greasing the bearings, keep all dirt out of the area. Wipe the fittings completely clean and use clean equipment. More bearing failures are caused by dirt introduced during greasing than from insufficient grease.

RECEPTACLES: Keep the electrical receptacles in good condition. Remove any dirt, oil, or other debris from their surfaces and holes.

CABLE CONNECTIONS: Check the welding cable connections at the weld output terminals often. Be sure that the connections are always tight.

VANTAGE® 500



BATTERY MAINTENANCE

WARNING



GASES FROM BATTERY can explode.

- Keep sparks, flame, and cigarettes away from battery.



BATTERY ACID can burn eyes and skin.

- Wear gloves and eye protection and be careful when working near a battery. Follow the instructions printed on the battery.

To prevent EXPLOSION when:

- **INSTALLING A NEW BATTERY** - Disconnect the negative cable from the old battery first and connect to the new battery last.
- **THE CORRECT POLARITY IS NEGATIVE GROUND** - Damage to the engine alternator and the printed circuit board can result from incorrect connection.



- **CONNECTING A BATTERY CHARGER** - Remove the battery from the welder by disconnecting the negative cable first, then the positive cable and battery clamp. When reinstalling, connect the negative cable last. Keep the area well ventilated.

- **USING A BOOSTER** - Connect the positive lead to the battery first, then connect the negative lead to the engine foot.
- To prevent BATTERY BUCKLING, tighten the nuts on the battery clamp until snug.

CLEANING THE BATTERY: Keep the battery clean by wiping it with a damp cloth when dirty. If the terminals appear corroded, disconnect the battery cables and wash the terminals with an ammonia solution or a solution of 1/4 pound (0.113 kg) of baking soda and 1 quart (0.946 l) of water. Be sure the battery vent plugs (if equipped) are tight so that none of the solution enters the cells.

After cleaning, flush the outside of the battery, the battery compartment, and surrounding areas with clear water. Coat the battery terminals lightly with petroleum jelly or a non-conductive grease to retard corrosion.

Keep the battery clean and dry. Moisture accumulation on the battery can lead to more rapid discharge and early battery failure.

CHECKING SPECIFIC GRAVITY: Check each battery cell with a hydrometer. A fully charged battery will have a specific gravity of 1.260. Charge the battery if the reading is below 1.215.

NOTE: Correct the specific gravity reading by adding four gravity points (0.004) for every five degrees the electrolyte temperature is above 80 degrees F (27 degrees C). Subtract four gravity points (.004) for every five degrees the electrolyte temperature is below 80 degrees F (27 degrees C).

CHECKING ELECTROLYTE LEVEL: If battery cells are low, fill them to the neck of the filler hole with distilled water and recharge. If one cell is low, check for leaks.

CHARGING THE BATTERY: The Vantage 500 is equipped with a wet charged battery. The charging current is automatically regulated when the battery is low (after starting the engine) to a trickle current when the battery is fully charged.

When you charge, jump, replace, or otherwise connect battery cables to the battery, be sure the polarity is correct. Improper polarity can damage the charging circuit. **The Vantage 500 charging system is NEGATIVE GROUND.** The positive (+) battery terminal has a red terminal cover.

If you need to charge the battery with an external charger, disconnect the negative cable first, then the positive cable before you attach the charger leads. After the battery is charged, reconnect the positive battery cable first and the negative cable last. Failure to do so can result in damage to the internal charger components.

Follow the instructions of the battery charger manufacturer for proper charger settings and charging time.

FIGURE D.5 – MAJOR COMPONENT LOCATIONS

- | | |
|----------------------------------|------------------------|
| 1. CONTROL PANEL ASSEMBLY | 6A. ENGINE ASSEMBLY |
| 2. CONTROL BOX & OUTPUT ASSEMBLY | 7. GENERATOR FRAME |
| 3. POWER MODULE ASSEMBLY | 8. SOLENOID ASSEMBLY |
| 4. BASE & LIFT BAILE ASSEMBLY | 9. CASEBACK |
| 5. FUEL TANK & MOUNTING | 10. CASE TOP AND SIDES |

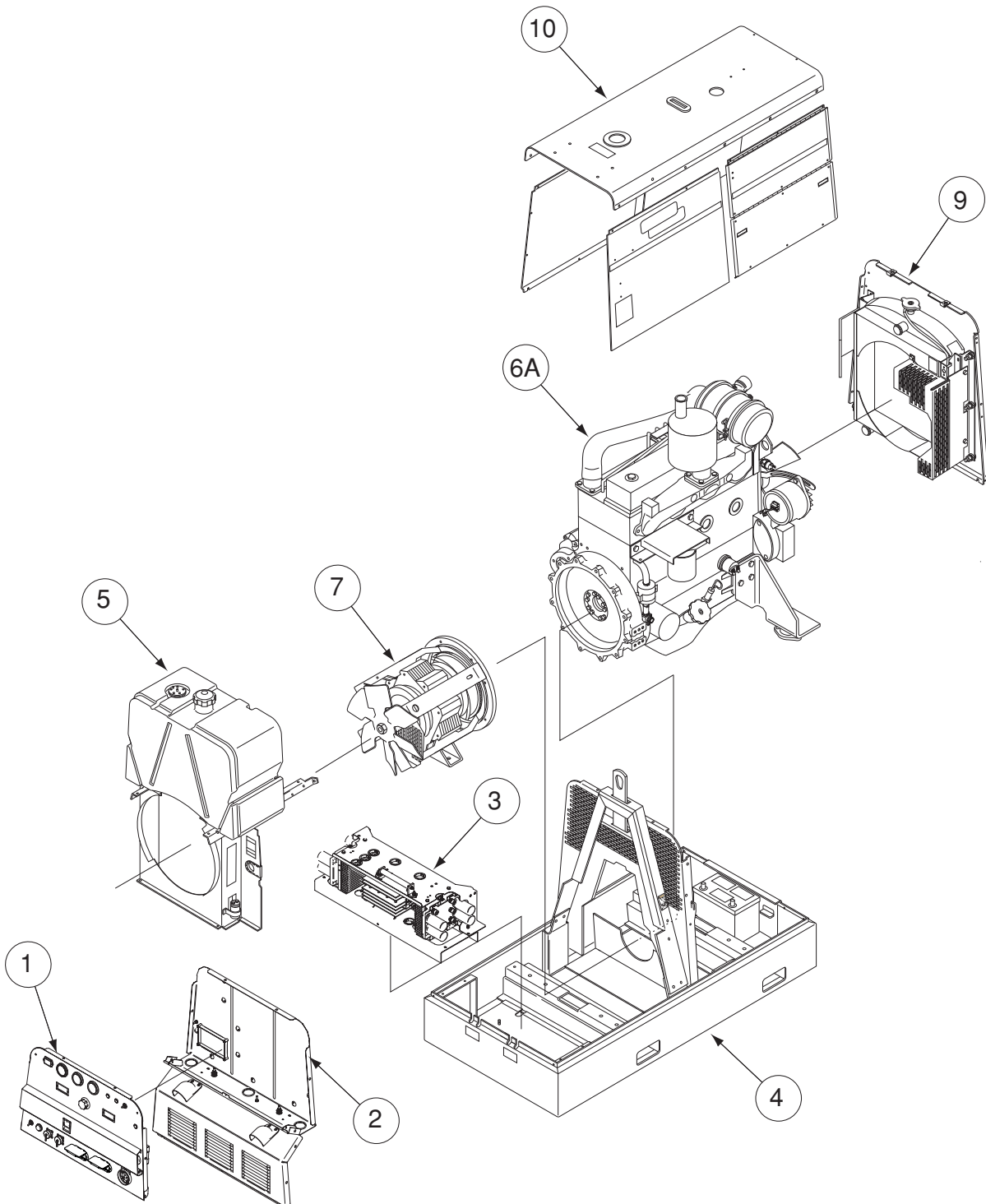

VANTAGE® 500

Return to Section TOC

Return to Section TOC

Return to Section TOC

Return to Section TOC

Return to Master TOC

Return to Master TOC

Return to Master TOC

Return to Master TOC

VANTAGE® 500



Installation - VANTAGE® 500 Cummins B3.3 (Code 11181, 11416)

Technical Specifications	A5.2
Safety Precautions	A5.3
Location/Ventilation	A5.3
Storing	A5.3
Stacking	A5.3
Angle of Operation	A5.3
Lifting	A5.4
High Altitude Operation	A5.4
High Temperature Operation	A5.4
Towing	A5.4
Vehicle Mounting	A5.4
Pre-Operation Engine Service	A5.5
Oil	A5.5
Fuel	A5.5
Fuel Cap	A5.5
Engine Cooling System	A5.5
Battery Connection	A5.5
Muffler Outlet Pipe	A5.6
Spark Arrester	A5.6
High Frequency Generators for TIG Applications	A5.6
Electrical Connections	A5.6
Remote Control	A5.6
Welding Terminals	A5.6
Welding Output Cables	A5.7
Machine Grounding	A5.7
Auxiliary Power Receptacles	A5.7
Standby Power Connections	A5.7

TECHNICAL SPECIFICATIONS - VANTAGE 500 CUMMINS (K2406-1)

INPUT - DIESEL ENGINE					
Make /Model	Description	Speed (RPM)	Displacement	Starting System	Capacities
CUMMINS B3.3 Diesel Engine	4 cylinder 53HP (40 kw) @ 1800 RPM	High Idle 1890 Low Idle 1400 Full Load 1890	199 cu. in (3.3L) Bore x Stroke 3.74" x 4.53" (95mm x 115mm)	12VDC battery & Starter	Fuel 25 US gal. (94.6L) Oil: 2 US gal. (7.6L) Coolant 2 US gal. (7.6L)
RATED OUTPUT @ 104°F(40°C) - WELDER					
Duty Cycle	Welding Output		Volts at Rated Amps		
100%	500 Amps (DC multi-purpose)		40 Volts		
60%	550 Amps (DC multi-purpose)		36 volts		
50%	575 Amps (DC multi-purpose)		35 volts		
OUTPUT @ 104°F(40°C) - WELDER AND GENERATOR					
Welding Range 30 - 575 Amps CC/CV 20 - 250 Amps TIG					
Open Circuit Voltage 60 Max OCV @ 1900 RPM					
Auxiliary Power ⁽¹⁾ 120/240 VAC 12,000 WATTS, 60 Hz., Single Phase 20,000 WATTS, 60 Hz., Three Phase					
PHYSICAL DIMENSIONS					
Height ⁽²⁾	Width	Depth	Weight		
42.0 in (1066.8 mm)	31.5 in. (800.1mm)	63.1 in. (1603mm)	1443lbs. (655kg) (Approx)		

- Output rating in watts is equivalent to volt-amperes at unity power factor.
Output voltage is within +/- 10% at all loads up to rated capacity. When welding, available auxiliary power will be reduced.
- Top of Enclosure. Add 7.0" (177.8mm) for exhaust.

VANTAGE® 500

Read this entire installation section before you start installation.

SAFETY PRECAUTIONS



WARNING

Do not attempt to use this equipment until you have thoroughly read all operating and maintenance manuals supplied with your machine. They include important safety precautions, \detailed engine starting, operating and maintenance instructions and parts lists.

ELECTRIC SHOCK can kill.



- Do not touch electrically live parts such as output terminals or internal wiring.
- Insulate yourself from the work and ground.
- Always wear dry insulating gloves.

ENGINE EXHAUST can kill.



- Use in open, well ventilated areas or vent exhaust outside
- Do not stack anything near the engine.

MOVING PARTS can injure.



- Do not operate with doors open or guards off.
- Stop engine before servicing.
- Keep away from moving parts

Only qualified personnel should install, use or service this equipment

LOCATION / VENTILATION

The welder should be located to provide an unrestricted flow of clean, cool air to the cooling air inlets and to avoid restricting the cooling air outlets. Also, locate the welder so that the engine exhaust fumes are properly vented to an outside area.



CAUTION

DO NOT MOUNT OVER COMBUSTIBLE SURFACES

Where there is a combustible surface directly under stationary or fixed electrical equipment, that surface should be covered with a steel plate at least .06”(1.6mm) thick, which should extend not less than 5.90”(150mm) beyond the equipment on all sides.

STORING

1. Store the machine in a cool, dry place when it is not in use. Protect it from dust and dirt. Keep it where it can't be accidentally damaged from construction activities, moving vehicles, and other hazards.
2. Drain the engine oil and refill with fresh 10W30 oil. Run the engine for about five minutes to circulate oil to all the parts. See the **MAINTENANCE** section of this manual for details on changing oil.
3. Remove the battery, recharge it, and adjust the electrolyte level. Store the battery in a dry, dark place.

STACKING

Vantage 500 machines cannot be stacked.

ANGLE OF OPERATION

To achieve optimum engine performance the Vantage should be run in a level position. The maximum angle of operation for the Cummins engine is 35 degrees in all directions. If the engine is to be operated at an angle, provisions must be made for checking and maintaining the oil level at the normal (FULL) oil capacity in the crankcase. When operating the welder at an angle, the effective fuel capacity will be slightly less than the specified 25 gallons.

LIFTING

The Vantage lift bale should be used to lift the machine. The Vantage is shipped with the lift bale retracted. Before attempting to lift the Vantage, secure the lift bale in a raised position. Secure the lift bale as follows:

- Open the engine compartment door.
- Locate the two access holes on the upper middle region of the compartment wall just below the lift bale.
- Use the lifting strap to raise the lift bale to the full upright position. This will align the mounting holes on the lift bale with the access holes.
- Secure the lift bale with 2 thread forming screws. The screws are provided in the loose parts bag shipped with the machine.

WARNING

FALLING EQUIPMENT can cause injury.



- Do not lift this machine using lift bale if it is equipped with a heavy accessory such as a trailer or gas cylinder.
- Lift only with equipment of adequate lifting capacity.
- Be sure machine is stable when lifting.

HIGH ALTITUDE OPERATION

At higher altitudes, output derating may be necessary. For maximum rating, derate the welder output 5% for every 300 meters (984 ft.) above 1500 meters (4920 ft.). For output of 500A and below, derate the welder output 5% for every 300 meters (984 ft.) above 2100 meters (6888 ft.).

Contact a Cummins Service Representative for any engine adjustments that may be required.

HIGH TEMPERATURE OPERATION

At temperatures above 40°C (104°F), output voltage derating may be necessary. For maximum output current ratings, derate the welder voltage rating two volts for every 10°C (21°F) above 40°C (104°F).

TOWING

The recommended trailer for use with this equipment for road, in-plant and yard towing by a vehicle¹ is Lincoln's K953-1. If the user adapts a non-Lincoln trailer, he must assume responsibility that the method of attachment and usage does not result in a safety hazard nor damage the welding equipment. Some of the factors to be considered are as follows:

- Design capacity of the trailer vs. weight of the Lincoln equipment and likely additional attachments.
- Proper support of, and attachment to, the base of the welding equipment so that there will be no undue stress to the trailer's framework.
- Proper placement of the equipment on the trailer to insure stability side to side and front to back when being moved and when standing by itself.
- Typical conditions of use, such as travel speed, roughness of surface on which the trailer will be operated, and environmental conditions.
- Proper preventative maintenance of the trailer.
- Conformance with federal, state and local laws.¹

¹Consult applicable federal, state and local laws regarding specific requirements for use on public highways.

VEHICLE MOUNTING

WARNING

Improperly mounted concentrated loads may cause unstable vehicle handling and tires or other components to fail.

- **Only transport this Equipment on serviceable vehicles which are rated and designed for such loads.**
- **Distribute, balance and secure loads so vehicle is stable under conditions of use.**
- **Do not exceed maximum rated loads for components such as suspension, axles and tires.**
- **Mount equipment base to metal bed or frame of vehicle.**
- **Follow vehicle manufacturer's instructions.**

PRE-OPERATION ENGINE SERVICE

READ the engine operating and maintenance instructions supplied with this machine.

WARNING



- Keep hands away from the engine muffler or HOT engine parts.
- Stop engine and allow to cool before fueling.
- Do not smoke when fueling.
- Fill fuel tank at a moderate rate and do not overfill.
- Wipe up spilled fuel and allow fumes to clear before starting engine.
- Keep sparks and flame away from tank.

OIL

The Vantage is shipped with the engine crankcase filled with high quality SAE 10W-30 oil (API class CD or better). Check the oil level before starting the engine. If it is not up to the full mark on the dip stick, add oil as required. Check the oil level every four hours of running time during the first 35 running hours. Refer to the engine Operator's Manual for specific oil recommendations and break-in information. The oil change interval is dependent on the quality of the oil and the operating environment. Refer to the engine Operator's Manual for the proper service and maintenance intervals.

FUEL

NOTE: USE DIESEL FUEL ONLY.



Fill the fuel tank with clean, fresh diesel fuel. The capacity of the fuel tank is approx 95 liters. See engine Operator's Manual for specific fuel recommendations. **Running out of fuel may require bleeding the fuel injection pump.** **NOTE:** Before starting the engine, open the fuel shutoff valve (pointer to be in line with hose).

NOTE: Before starting the engine, open the fuel shut-off valve (pointer to be in line with hose).

FUEL CAP

Remove the plastic cap covering from the fuel tank filler neck and install the fuel cap.

ENGINE COOLING SYSTEM

WARNING



HOT COOLANT can burn skin.

- Do not remove cap if radiator is hot.

The welder is shipped with the engine and radiator filled with a 50% mixture of ethylene glycol and water. See the MAINTENANCE section and the engine Operator's Manual for more information on coolant.

WARNING

BATTERY CONNECTION

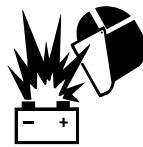

GASES FROM BATTERY can explode.

- Keep sparks, flame and cigarettes away from battery.

To prevent EXPLOSION when:

- **INSTALLING A NEW BATTERY** — disconnect negative cable from old battery first and connect to new battery last.
- **CONNECTING A BATTERY CHARGER** — remove battery from welder by disconnecting negative cable first, then positive cable and battery clamp. When reinstalling, connect negative cable last. Keep well ventilated.
- **USING A BOOSTER** — connect positive lead to battery first then connect negative lead to negative battery lead at engine foot.

WARNING



BATTERY ACID can burn eyes and skin.

- Wear gloves and eye protection and be careful when working near battery.
- Follow instructions printed on battery.

IMPORTANT: To prevent ELECTRICAL DAMAGE WHEN:

- a) Installing new batteries
- b) Using a booster

Use correct polarity — **Negative Ground.**

The Vantage is shipped with the negative battery cable disconnected. Before you operate the machine, make sure the Engine Switch is in the OFF position and attach the disconnected cable securely to the negative (-) battery terminal.

Remove the insulating cap from the negative battery terminal. Replace and tighten the negative battery cable terminal.

NOTE: This machine is furnished with a wet charged battery; if unused for several months, the battery may require a booster charge. Be sure to use the correct polarity when charging the battery.

MUFFLER OUTLET PIPE

Remove the plastic plug covering the muffler outlet tube. Using the clamp provided, secure the outlet pipe to the outlet tube with the pipe positioned to direct the exhaust in the desired direction.

SPARK ARRESTER

Some federal, state or local laws may require that gasoline or diesel engines be equipped with exhaust spark arresters when they are operated in certain locations where unarrested sparks may present a fire hazard. The standard muffler included with this welder does not qualify as a spark arrester. When required by local regulations, a suitable spark arrester must be installed and properly maintained.

CAUTION

An incorrect arrester may lead to damage to the engine or adversely affect performance.

HIGH FREQUENCY GENERATORS FOR TIG APPLICATIONS

The K799 Hi-Freq Unit (obsolete) and the K930-1 or-2 TIG Module are suitable for use with the Vantage 500. The Vantage 500 is equipped with the required R.F. bypass circuitry for the connection of high frequency generating equipment. The high frequency bypass network supplied with the K799 Hi-Freq Unit does NOT need to be installed into the Vantage 500.

The Vantage 500 and any high frequency generating equipment must be properly grounded. See the K799 Hi-Freq Unit and the K930-1 or-2 TIG Module operating manuals for complete instructions on installation, operation, and maintenance.

ELECTRICAL CONNECTIONS

REMOTE CONTROL

The Vantage 500 is equipped with a 6-pin and a 14-pin connector. The 6-pin connector is for connecting the K857 or K857-1 Remote Control (optional) or, in the case of TIG welding applications, with the foot or hand Amptrol (K870 or K963-1 respectively).

The 14-pin connector is used to directly connect a wire feeder or TIG Module (K930-1 or-2) control cable.

NOTE: When using the 14-pin connector, if the wire feeder has a built-in power source output control, do not connect anything to the 6-pin connector.

WELDING TERMINALS

The Vantage is equipped with a toggle switch for selecting "hot" welding terminals when in the "WELD TERMINALS ON" position or "cold" welding terminals when in the "WELDING TERMINALS REMOTELY CONTROLLED" position.

WELDING OUTPUT CABLES

With the engine off, route the electrode and work cables through the strain relief bracket provided on the front of the base and connect to the terminals provided. These connections should be checked periodically and tightened if necessary.

Listed in Table A5.1 are copper cable sizes recommended for the rated current and duty cycle. Lengths stipulated are the distance from the welder to work and back to the welder again. Cable sizes are increased for greater lengths primarily for the purpose of minimizing cable voltage drop.

TABLE A5.1 – COMBINED LENGTH OF ELECTRODE AND WORK CABLES

Amps @ 100% Duty Cycle	Total Combined Length of Electrode and Work Cables		
	Up to 150 ft.	150-200 ft.	200-250 ft.
500	3/0 AWG	3/0 AWG	4/0 AWG

MACHINE GROUNDING

Because this portable engine driven welder creates its own power, it is not necessary to connect its frame to an earth ground, unless the machine is connected to premises wiring (home, shop, etc.).

To prevent dangerous electric shock, other equipment powered by this engine driven welder must:

- a) be grounded to the frame of the welder using a grounded type plug,

or

- b) be double insulated.

When this welder is mounted on a truck or trailer, its frame must be securely connected to the metal frame of the vehicle. When this engine driven welder is connected to premises wiring such as that in a home or shop, its frame must be connected to the system earth ground. See further connection instructions in the section entitled **Standby Power Connections** as well as the article on grounding in the latest U.S. National Electrical Code and the local code.

In general, if the machine is to be grounded, it should be connected with a #8 or larger copper wire to a solid earth ground such as a metal water pipe going into the ground for at least ten feet and having no insulated joints, or to the metal framework of a building which has been effectively grounded. The U.S. National Electrical Code lists a number of alternate means of grounding electrical equipment. A machine grounding stud marked with the \oplus symbol is provided on the front of the welder.

AUXILIARY POWER RECEPTACLES

The auxiliary power capacity of the Vantage 500 is 12,000 watts of 60 Hz, single-phase power. The auxiliary power capacity rating in watts is equivalent to volt-amperes at unity power factor. The maximum permissible current of the 240 VAC output is 50 A. The 240 VAC output can be split to provide two separate 120 VAC outputs with a maximum permissible current of 50 A per output to two separate 120 VAC branch circuits. The output voltage is within $\pm 10\%$ at all loads up to rated capacity.

NOTE: The 120/240V receptacle has two 120V outlets of different phases and cannot be paralleled.

The Vantage has two 20A-120VAC (5-20R) duplex receptacles and one 50A-120/240 VAC (14-50R) receptacle. The 120/240 VAC receptacle can be split for single-phase 120 VAC operation. The auxiliary power receptacles should only be used with three-wire grounded type plugs or approved double insulated tools with two-wire plugs. The current rating of any plug used with the system must be at least equal to the current capacity of the associated receptacle.

STANDBY POWER CONNECTIONS

The Vantage 500 is suitable for temporary, standby or emergency power using the engine manufacturer's recommended maintenance schedule.

The Vantage 500 can be permanently installed as a standby power unit for 240 volt, three-wire, 50 amp service. Connections must be made by a licensed electrician who can determine how the 120/240 VAC power can be adapted to the particular installation and comply with all applicable electrical codes. The following information can be used as a guide by the electrician for most applications. Refer to the connection diagram shown in **Figure A5.1**.

1. Install the double-pole, double-throw switch between the power company meter and the premises disconnect.
- Switch rating must be the same or greater than the customer's premises disconnect and service over current protection.
2. Take necessary steps to assure load is limited to the capacity of the Vantage by installing a 50 amp, 240 VAC double-pole circuit breaker. Maximum rated load for each leg of the 240 VAC auxiliary is 50 amperes. Loading above the rated output will reduce output voltage below the allow-

- able -10% of rated voltage, which may damage appliances or other motor-driven equipment and may result in overheating of the Vantage 500 engine.
3. Install a 50 amp 120/240 VAC plug (NEMA Type 14-50) to the double-pole circuit breaker using four-conductor cable of the proper size and desired length. (The 50 amp, 120/240 VAC plug is available in the optional K802R plug kit.)
 4. Plug this cable into the 50 amp 120/240 volt receptacle on the Vantage 500 case front.

Figure A5.1 Connection of the Vantage to Premises Wiring

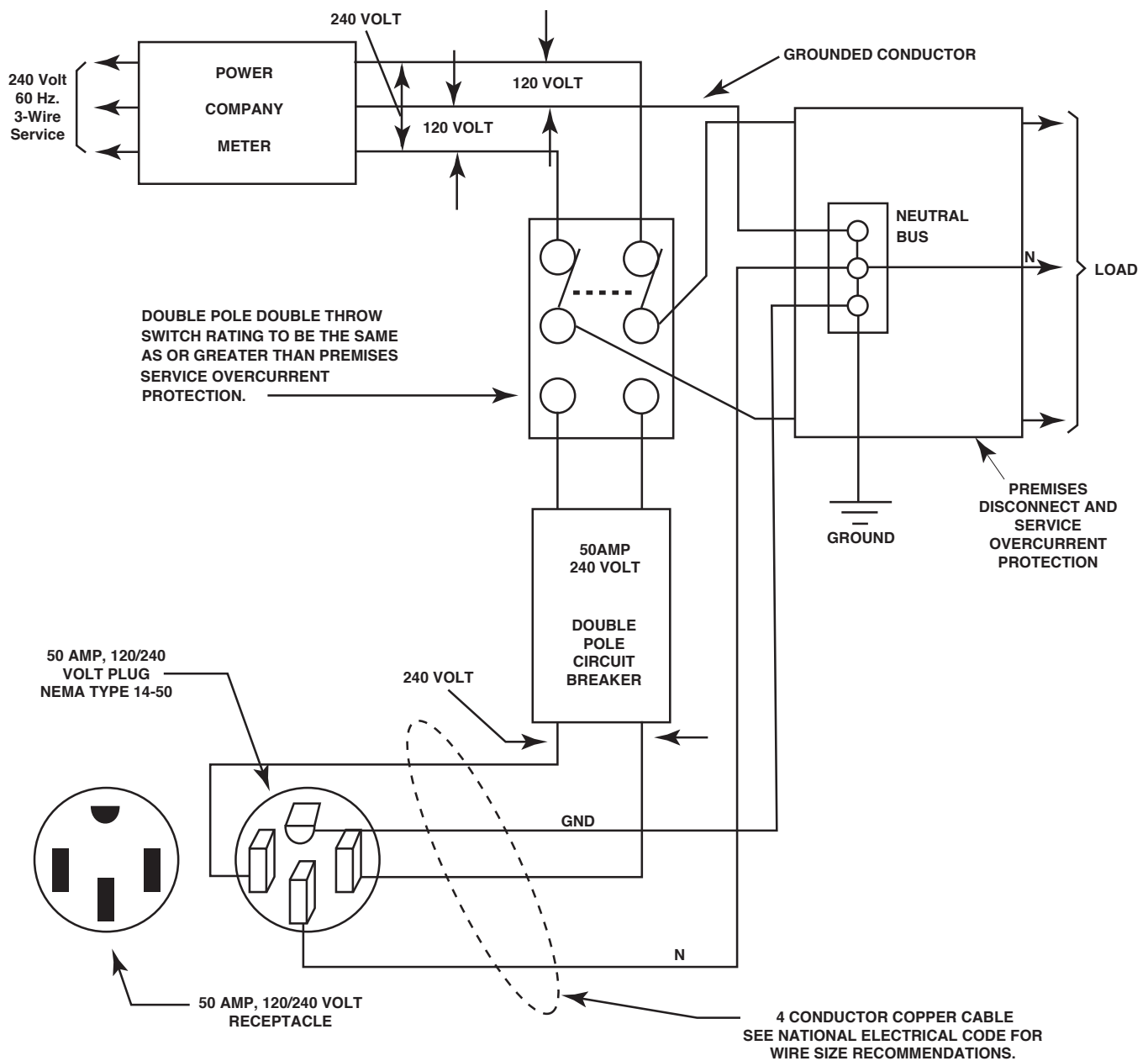

Operation - VANTAGE® 500 Cummins B3.3 (Codes 11181 & 11416)

Operating InstructionsB5.2

Safety InstructionsB5.2

General DescriptionB5.2

 Recommended ApplicationsB5.3

 Design Features and AdvantagesB5.3

Controls and SettingsB5.4

 Engine ControlsB5.4

 Welding ControlsB5.6

 Auxiliary Power ControlsB5.6

Engine OperationB5.7

 Starting the EngineB5.7

 Stopping the EngineB5.7

 Typical Fuel ConsumptionB5.7

Welder OperationB5.8

 Stick WeldingB5.8

 Constant Current (CC) WeldingB5.8

 Pipe WeldingB5.8

 TIG WeldingB5.8

 Wire Feed (Constant Voltage) WeldingB5.10

Auxiliary Power OperationB5.10

 Arc GougingB5.10

 ParallelingB5.10

Simultaneous Welding and Auxiliary Power LoadsB5.11

Extension Cord RecommendationsB5.11

Return to Master TOC

Return to Master TOC

Return to Master TOC

Return to Master TOC

OPERATING INSTRUCTIONS

Read and understand this entire section before operating your Vantage 500.

SAFETY INSTRUCTIONS

WARNING

Do not attempt to use this equipment until you have thoroughly read all operating and maintenance manuals supplied with your machine. They include important safety precautions: detailed engine starting, operating, and maintenance instructions and parts lists.

ELECTRIC SHOCK can kill.



- Do not touch electrically live parts or electrodes with your skin or wet clothing.
- Insulate yourself from the work and ground.
- Always wear dry insulating gloves.

FUMES AND GASES CAN BE DANGEROUS.



- Keep your head out of fumes.
- Use ventilation or exhaust to remove fumes from breathing zone.

WELDING SPARKS CAN CAUSE FIRE OR EXPLOSION.



- Keep flammable material away.
- Do not weld on containers that have held combustibles.

ARC RAYS CAN BURN.



- Wear eye, ear, and body protection.



ENGINE EXHAUST can kill.

- Use in open, well ventilated areas or vent exhaust outside
- Do not stack anything near the engine.



MOVING PARTS can injure.

- Do not operate with doors open or guards off.
- Stop engine before servicing.
- Keep away from moving parts

Only qualified personnel should operate this equipment.

ADDITIONAL SAFETY PRECAUTIONS

Always operate the welder with the hinged door closed and the side panels in place, as these provide maximum protection from moving parts and insure proper cooling air flow.

GENERAL DESCRIPTION

The Vantage 500 is a diesel engine-driven welding power source. The machine uses a brush type alternating current generator for DC multi-purpose welding and for 120/240 VAC auxiliary standby power. The welding control system uses state of the art **Chopper Technology**.

The generator has a single sealed bearing for maintenance free service. The rotor is a copper wound design with two slip rings and brushes. The stator is wound entirely with heavy gauge copper wire and insulated with NEMA class F insulation material. The stator is then impregnated with three layers of high quality varnish. After the stator is assembled using tie bars, the entire assembly is covered with an environmentally protective coating. These measures insure trouble-free operation in the harshest environments.

The fuel tank is made from high density polyethylene and holds 25 gallons (94.6 liters) of diesel fuel. This will provide enough fuel to run for more than 12 hours at full load.

RECOMMENDED APPLICATIONS

WELDER

The Vantage 500 provides excellent constant current DC welding output for stick (SMAW) and TIG welding. The Vantage 500 also provides excellent constant voltage DC welding output for MIG (GMAW) and Innershield (FCAW) welding.

GENERATOR

The Vantage 500 provides smooth 120/240 VAC output for auxiliary power and emergency standby power.

DESIGN FEATURES AND ADVANTAGES

K1639-2 VANTAGE 500 DELUXE MODEL FEATURES

FOR WELDING

- Excellent DC multi-purpose welding for stick, MIG, TIG, cored wire and arc gouging applications.
- 30 to 500 amps output in five slope-controlled ranges for out-of position and pipe electrodes, one constant current output range for general purpose welding, one constant voltage range for MIG wire and cored wire welding and one 20-250 amp range for "Touch Start" TIG welding.
- 100% duty cycle at 500 amps output and 50% duty cycle at 575 amps output.
- Dual 3-digit output meters are provided (optional on K1639-1) for presetting the weld amperage or voltage and displaying the actual amperage and voltage during welding. The meters use superbrite L.E.D.'s for improved readability in full sunlight.

LOOK-BACK FEATURE: After welding has stopped, both displays will remain on for 7 seconds with the last current and voltage value displayed. During this time, the left-most decimal point in each display will be FLASHING.

- Standard remote control capability with 14-pin and 6-pin connectors for easy connection of Lincoln remote control accessories.
- An internal "Solid State" contactor allows for the selection of "hot" or "cold" output terminals with a toggle switch on the control panel.
- "Arc Control" potentiometer in Wire and Stick modes for precise adjustment of arc characteristics.
- Advanced circuitry to prevent pop-outs in the five slope modes.

FOR AUXILIARY POWER

- 12,000 watts of 120/240 VAC, 60Hz auxiliary power.
- 20,000 watts of 240VAC, 60Hz. 3 phase power.
- Power for tools, 120/240 VAC lights, electric pumps and for standby emergency power.
- Drive a 5 HP motor (provided it is started under no load).
- Two 20 amp 120 VAC duplex receptacles for up to 40 amps of 120 VAC power.
- One 50 amp, 120/240 VAC dual voltage receptacle for up to 50 amps of 240 VAC, and up to 50 amps per side to separate branch circuits (not in parallel) of 120 VAC single-phase auxiliary power. Allows easy connection to premises wiring.
- Weld and AC auxiliary power at the same time (within machine total capacity).

OTHER FEATURES

- Cummins 4 cylinder/4 cycle engine. Designed for long life, easy maintenance, and excellent fuel economy.
- Engine protection system shuts the engine down for low oil pressure, high oil temperature, or a broken fan/engine alternator belt.
- Gauges for oil pressure, oil temperature, engine alternator output, and fuel level.
- Indicator lights for Engine Protection, and Battery (engine alternator low output/broken belt).
- Engine hour meter standard on all models.
- Extended range 25 gallon (94.6 l) fuel tank.
- Automatic idler reduces engine speed when not welding or drawing auxiliary power. This feature reduces fuel consumption and extends engine life.
- Compact size fits crosswise in full size pickup truck.
- Single-side engine service.
- Copper alternator windings and high temperature insulation for dependability and long life.
- New paint system on case and base for outstanding corrosion protection.

CONTROLS AND SETTINGS

All welder and engine controls are located on the case front. Refer to Figure B5.1 and the explanations that follow.

Figure B5.1 Case Front Panel Controls

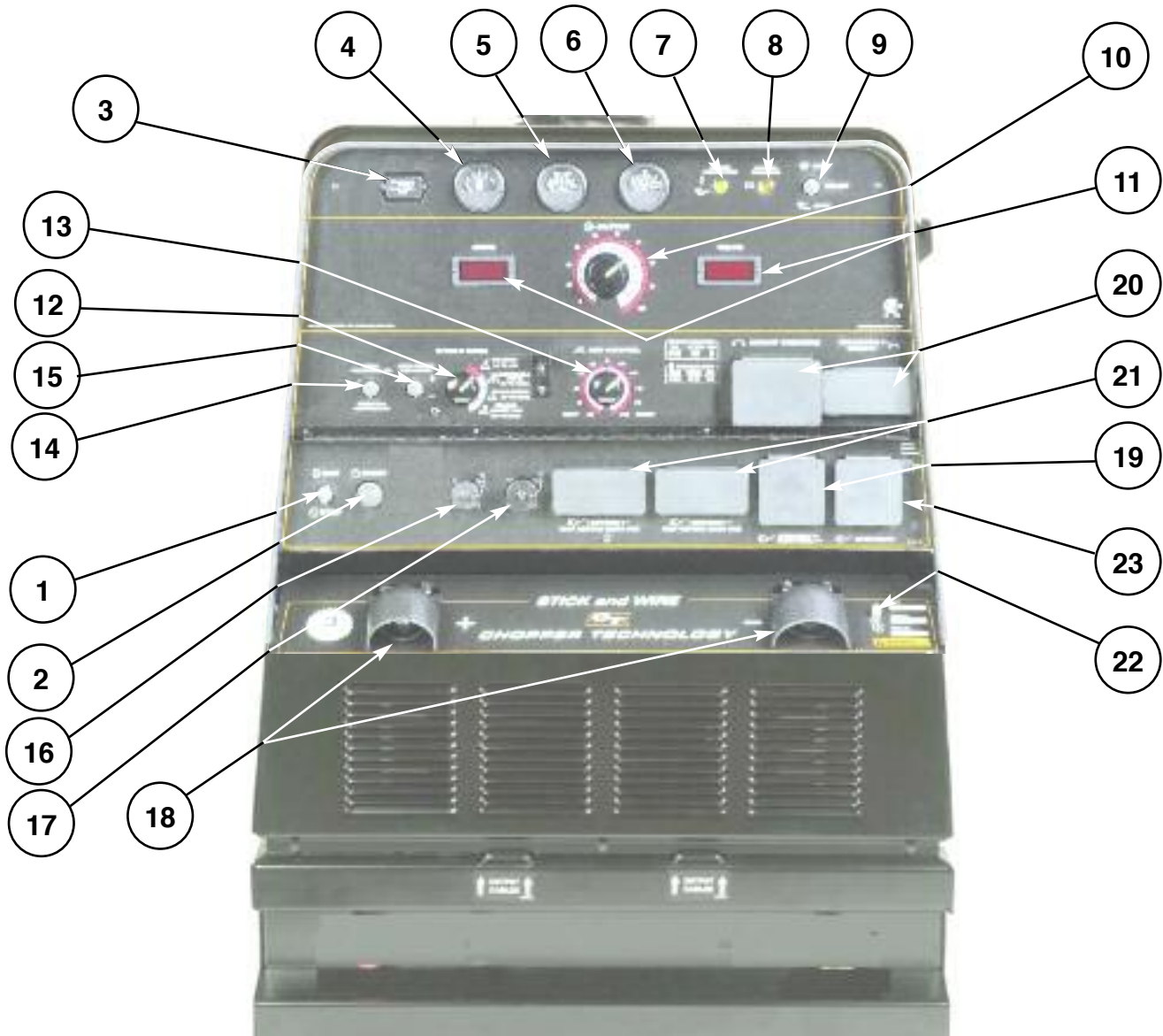

ENGINE CONTROLS (Items 1 through 9)

1. RUN STOP SWITCH

Toggleing the switch to the RUN position energizes the fuel solenoid for approximately 30 seconds. The engine must be started within that time or the fuel solenoid will deenergize, and the switch must be toggled to reset the timer.

2. START PUSHBUTTON

Energizes the starter motor to crank the engine. With the engine "Run / Stop" switch in the "Run" position, push and hold the Start button to crank the engine; release as the engine starts. Do not press while engine is running since this can cause damage to the ring gear and/or starter motor

3. HOUR METER

The hour meter displays the total time that the engine has been running. This meter is a useful indicator for scheduling preventive maintenance.

4. FUEL LEVEL GAUGE

Displays the level of diesel fuel in the fuel tank.

The operator must watch the fuel level closely to prevent running out of fuel and possibly having to bleed the system.

5. ENGINE TEMPERATURE GAUGE

The gauge displays the engine coolant temperature.

VANTAGE® 500

LINCOLN
ELECTRIC

6. OIL PRESSURE GAUGE



The gauge displays the engine oil pressure when the engine is running.

7. ENGINE PROTECTION

The yellow engine protection light remains off with proper oil pressure and under normal operating temperatures. If the light turns on, the engine protection system will stop the engine. Check for proper oil and coolant levels and add oil and/or coolant if necessary. Check for loose or disconnected leads at the oil pressure sender located on the engine. The light will remain on when the engine has been shut down due to low oil pressure or over-temperature condition.

NOTE: This engine is equipped with an electronic governor system. The engine speed ramps up during a warm up period. The complete cycle takes approximately 3 minutes. This allows the engine cylinder temperature to build up slowly before going to full speed. This feature is bypassed if the engine is already warm. The Engine may produce “White Smoke” for a few minutes at low temperatures. Do not apply a load to the machine during the warm up period.



8. BATTERY CHARGING LIGHT



The yellow engine alternator light is off when battery charging system is functioning normally. If light turns on the alternator or the voltage regulator may not be operating correctly. The light will remain on when the engine is stopped and the run/stop switch is in the run position.

9. IDLER SWITCH

Has two positions as follows:

- A) In the “High” position,  the engine runs at the high idle speed controlled by the governor.
- B) In the “Auto”  /  position, the idler operates as follows:
- When switched from “High” to “Auto” or after starting the engine, the engine will operate at full speed for approximately 12 seconds and then go to low idle speed.
 - When the electrode touches the work or power is drawn for lights or tools (approximately 100 Watts minimum) the engine accelerates and operates at full speed.
 - When welding ceases and the AC power load is turned off, a fixed time delay of approximately 12 seconds starts.

- If the welding or AC power load is not restarted before the end of the time delay, the idler reduces the engine speed to low idle speed.
- The engine will automatically return to high idle speed when the welding load or A.C. power load is reapplied.

Idler Operational exceptions

When the WELDING TERMINALS switch is in the “Remotely Controlled” position the idler will operate as follows:

- When the triggering device (Amptrol, Arc Start Switch, etc.) is pressed the engine will accelerate and operate at full speed provided a welding load is applied within approximately 12 seconds.
- If the triggering device remains pressed but no welding load is applied within approximately 12 seconds the engine may return to low idle speed.
- If the triggering device is released or welding ceases the engine will return to low idle speed after approximately 12 seconds.

WELDING CONTROLS (Items 10 through 19)

10. OUTPUT CONTROL: The OUTPUT dial is used to preset the output voltage or current as displayed on the digital meters for the four welding modes. When in the CC-STICK, DOWNHILL PIPE or CV-WIRE modes and when a remote control is connected to the 6-Pin or 14-Pin Connector, the auto-sensing circuit automatically switches the OUTPUT CONTROL from control at the welder to the remote control. In the CV-WIRE mode, when the wire feeder control cable is connected to the 14-Pin Connector, the auto-sensing circuit automatically makes OUTPUT CONTROL inactive and the wire feeder voltage control active.

When in the TOUCH START TIG mode and when a Amptrol is connected to the 6-Pin Connector, the OUTPUT dial is used to set the maximum current range of the CURRENT CONTROL of the Amptrol.

11. DIGITAL OUTPUT METERS:

The digital meters allow the output voltage (CV-WIRE mode) or current (CC-STICK, DOWNHILL PIPE and TIG modes) to be set prior to welding using the OUTPUT control knob. During welding, the meters display the actual output voltage (VOLTS) and current (AMPS). A memory feature holds the display of both meters on the seven seconds after welding is stopped. This allows the operator to read the actual current and voltage just prior to when welding was ceased. While the display is being held the left-most decimal point in each display will be flashing. The accuracy of the meters is $\pm 3\%$.

12. WELD MODE SELECTOR SWITCH:

(Provides four selectable welding modes)

CV-WIRE
DOWNHILL PIPE
CC-STICK
TOUCH START TIG

13. ARC CONTROL:

The ARC CONTROL WIRE/STICK knob is active in the WIRE and STICK modes, and has different functions in these modes. This control is not active in the TIG mode.

CC-STICK mode: In this mode, the ARC CONTROL knob sets the short circuit current (arc-force) during stick welding. Increasing the number from -10(Soft) to +10(Crisp) increases the short circuit current and prevents sticking of the electrode to the plate while welding. This can also increase spatter. It is recommended that the ARC CONTROL be set to the minimum number without electrode sticking. Start with a setting at 0.

DOWNHILL PIPE mode: In this mode, the ARC CONTROL knob sets the short circuit current (arc-force) during stick welding to adjust for a soft or a more forceful digging arc (Crisp). Increasing the number from -10(Soft) to +10(Crisp) increases the short circuit current which results in a more forceful digging arc. Typically a forceful digging arc is preferred for root and hot passes. A softer arc is preferred for fill and cap passes where weld puddle control and deposition ("stacking" of iron) are key to fast travel speeds. It is recommended that the ARC CONTROL be set initially at 0.

CV-WIRE mode: In this mode, turning the ARC CONTROL knob from -10(soft) to +10(crisp) changes the arc from soft and washed-in to crisp and narrow. It acts as an inductance/pinch control. The proper setting depends on the procedure and operator preference. Start with a setting of 0.

14. WELDING TERMINALS SWITCH

In the WELD TERMINALS ON position, the output is electrically hot all the time. In the REMOTELY CONTROLLED position, the output is controlled by a wire feeder or amptrol device, and is electrically off until a remote switch is depressed.

15. WIRE FEEDER VOLTMETER SWITCH:

Matches the polarity of the wire feeder voltmeter to the polarity of the electrode.

16. 6 - PIN CONNECTOR

For attaching optional remote control equipment. Includes auto-sensing remote control circuit.

17. 14 - PIN CONNECTOR

For attaching wire feeder control cables. Includes contactor closure circuit, auto-sensing remote control circuit, and 120VAC and 42VAC power.

NOTE: When a wire feeder with a built in welding voltage control is connected to the 14-pin connector, do not connect anything to the 6-pin connector.

18. WELD OUTPUT TERMINALS + AND -

These 1/2" - 13 studs with flange nuts provide welding connection points for the electrode and work cables. For positive polarity welding the electrode cable connects to the "+" terminal and the work cable connects to this "-" terminal. For negative polarity welding the work cable connects to the "+" terminal and the electrode cable connects to this "-" terminal.

AUXILIARY POWER CONTROLS

(Items 19-23)

19. 120/240 VAC SINGLE PHASE RECEPTACLE

This is a 120/240VAC (14-50R) receptacle that provides 240VAC or can be split for 120VAC single phase auxiliary power. This receptacle has a 50 amp rating. Refer to the AUXILIARY POWER RECEPTACLES section in the installation chapter for further information about this receptacle. Also refer to the AUXILIARY POWER OPERATION section later in this chapter.

20. CIRCUIT BREAKERS

These circuit breakers provide separate overload current protection for each 120V circuit at the 240V single phase receptacle, each 120V single phase receptacle, the 240V three phase receptacle, the 120VAC in the 14-Pin connector, the 42VAC in the 14-Pin connector and battery circuit overload protection.

21. 120VAC SINGLE PHASE RECEPTACLES

These two 120VAC (5-20R) receptacles with GFCI protection provide 120VAC single phase for auxiliary power. Each receptacle has a 20 amp total rating. They are designed to protect the user from the hazards of ground faults. When the GFCI has tripped there will be no voltage available from the receptacle. Refer to the AUXILIARY POWER RECEPTACLES section in the installation chapter for further information about these receptacles. Also refer to the AUXILIARY POWER OPERATION section later in this chapter.

22. GROUND STUD

Provides a connection point for connecting the machine case to earth ground. Refer to "MACHINE GROUNDING" in the Installation chapter for proper machine grounding information.

23. 240VAC THREE PHASE RECEPTACLE

This is a 240VAC (15-50R) receptacle that provides 240VAC three phase auxiliary power. This receptacle has a 50 amp rating.

ENGINE OPERATION

STARTING THE ENGINE

1. Open the engine compartment door and check that the fuel shutoff valve is in the open position (lever to be in line with the hose).
2. Check for proper oil level and coolant level. Close engine compartment door.
3. Remove all plugs connected to the AC power receptacles.
4. Set IDLER switch to "AUTO".
5. Set the RUN/STOP switch to "RUN". Observe that the engine protection and battery charging lights are on. The engine protection light may turn off after 5 seconds or remain on until the engine is started.
6. Within 30 seconds, press and hold the engine START button until the engine starts. If the engine does not start within 30 seconds the RUN/STOP switch must be returned to the STOP position, then return to step 5.

7. Release the engine START button when the engine starts.
8. Check that the engine protection and battery charging lights are off. Investigate any indicated problem.

NOTE: The engine will go through a 3 minute warm-up cycle if cold. If the engine coolant is still warm from recent operation, the engine will go immediately to high idle and then to low idle if the idle switch is in the "AUTO" position.

COLD WEATHER STARTING

With a fully charged battery and the proper weight oil, the engine should start satisfactorily even down to about 0°F(-18°C). If the engine must be frequently started below 10°(-12°C), it may be desirable to install the optional ether start kit (K887-1). Installation and operating instructions are included in the kits.

STOPPING THE ENGINE

1. Switch the RUN/STOP switch to "STOP". This turns off the voltage supplied to the shutdown solenoid. A backup shutdown can be accomplished by shutting off the fuel valve located on the fuel line.

TYPICAL FUEL CONSUMPTION

Refer to **Table B5.1** for typical fuel consumption of the VANTAGE 500 Engine for various operating scenarios.

Table B5.1
Cummins B3.3 Engine Fuel Consumption

	Cummins B3.3 56HP(42Kw) @1800 RPM	Running Time for 25GAL.(94.6L) (Hours)
Low Idle - no load 1425 RPM	.45 Gal./hour (1.7 Lts./hour)	55.6
High Idle - no load 1900 RPM	.81 Gal./hour (3.1 Lts./hour)	30.9
DC CC Weld Output 500 Amps @ 40 Volts	1.88 Gal./hour (7.1 Lts./hour)	13.3
Auxiliary Power 12,000 VA	1.23 Gal./hour (4.7 Lts./hour)	20.3

WELDER OPERATION

DUTY CYCLE

Duty Cycle is the ratio of the uninterrupted on-load duration to 10 minutes. The total time period of one complete on-load and no-load cycle is 10 minutes. For example, in the case of a 60% duty cycle, load is applied continuously for 6 minutes followed by a no-load period of 4 minutes.

STICK WELDING MODE

The Vantage can be used with a broad range of DC stick electrodes.

The MODE switch provides two stick welding settings as follows:

CC-STICK MODE

The CC-STICK position of the MODE switch is designed for horizontal, vertical-up and overhead welding with all types of electrodes, especially low hydrogen. The OUTPUT CONTROL knob adjusts the full output range for stick welding.

The ARC CONTROL knob sets the short circuit (arc-force) current during stick welding. Increasing the number from -10 (Soft) to +10 (Crisp) increases the short circuit current and prevents sticking of the electrode to the plate while welding. This can also increase spatter. It is recommended that the ARC CONTROL be set to the minimum number without electrode sticking. Start with the knob set at 0.

DOWNHILL PIPE MODE

This slope controlled setting is intended for “out-of-position” and “down hill” pipe welding where the operator would like to control the current level by changing the arc length. The OUTPUT CONTROL knob adjusts the full output range for pipe welding.

The ARC CONTROL knob sets the short circuit current (arc-force) during stick welding to adjust for a soft or a more forceful digging arc (Crisp). Increasing the number from -10 (Soft) to +10 (Crisp) increases the short circuit current which results in a more forceful digging arc. Typically a forceful digging arc is preferred for root and hot passes. A softer arc is preferred for fill and cap passes where weld puddle control and deposition (“stacking” of iron) are key to fast travel speeds. It is recommended that the ARC CONTROL be set initially at 0.

TOUCH START TIG MODE

The Vantage can be used in a wide variety of DC TIG welding applications.

The TOUCH START TIG setting of the MODE switch is for DC TIG (Tungsten Inert Gas) welding. To initiate a weld, the OUTPUT CONTROL knob is first set to the desired current and the tungsten is touched to the work. During the time the tungsten is touching the work there is very little voltage or current and, in general, avoids tungsten contamination. Then, the tungsten is gently lifted off the work in a rocking motion, which establishes the arc.

To stop the arc, simply lift the TIG torch away from the work piece. When the arc voltage reaches approximately 30 volts, the arc will go out and the machine will automatically reset to the touch start current level. The tungsten may then be retouched to the work piece to restrike the arc. The arc may also be started and stopped with an Amptrol or Arc Start Switch.

The ARC CONTROL is not active in the TIG mode.

In general the ‘Touch Start’ feature avoids tungsten contamination without the use of a Hi-frequency unit. If the use of a high frequency generator is desired, the K930-2 TIG Module can be used with the Vantage. The settings are for reference.

The Vantage is equipped with the required R.F. bypass circuitry for the connection of high frequency generating equipment.

The Vantage and any high frequency generating equipment must be properly grounded. See the K930-2 TIG Module operating manuals for complete instructions on installation, operation, and maintenance.

When using the TIG Module, the OUTPUT control on the Vantage is used to set the maximum range of the CURRENT CONTROL on the TIG Module or an Amptrol if connected to the TIG Module.

TABLE B5.2 – TYPICAL CURRENT RANGES¹ FOR TUNGSTEN ELECTRODES²

Tungsten Electrode Diameter in. (mm)	DCEN (-)	DCEP (+)	Approximate Argon Gas Flow Rate C.F.H. (l/min.)		TIG TORCH Nozzle Size ^{4,5}
	1%, 2% Thoriated Tungsten	1%, 2% Thoriated Tungsten	Aluminum	Stainless Steel	
0.010 (.25)	2-15	³	3-8 (2-4)	3-8 (2-4)	#4, #5, #6
0.020 (.50)	5-20	³	5-10 (3-5)	5-10 (3-5)	
0.40 (1.0)	15-80	³	5-10 (3-5)	5-10 (3-5)	
1/16 (1.6)	70-150	10-20	5-10 (3-5)	9-13 (4-6)	#5, #6
3/32 (2.4)	150-250	15-30	13-17 (6-8)	11-15 (5-7)	#6, #7, #8
1/8 (3.2)	250-400	25-40	15-23 (7-11)	11-15 (5-7)	
5/32 (4.0)	400-500	40-55	21-25 (10-12)	13-17 (6-8)	#8, #10
3/16 (4.8)	500-750	55-80	23-27 (11-13)	18-22 (8-10)	
1/4 (6.4)	750-1000	80-125	28-32 (13-15)	23-27 (11-13)	

¹When used with argon gas. The current ranges shown must be reduced when using argon/helium or pure helium shielding gases.

²Tungsten electrodes are classified as follows by the American Welding Society (AWS):

- Pure EWP
- 1% Thoriated EWTh-1
- 2% Thoriated EWTh-2

Though not yet recognized by the AWS, Ceriated Tungsten is now widely accepted as a substitute for 2% Thoriated Tungsten in AC and DC applications.

³DCEP is not commonly used in these sizes.

⁴TIG torch nozzle “sizes” are in multiples of 1/16ths of an inch:

- # 4 = 1/4 in. (6 mm)
- # 5 = 5/16 in. (8 mm)
- # 6 = 3/8 in. (10 mm)
- # 7 = 7/16 in. (11 mm)
- # 8 = 1/2 in. (12.5 mm)
- #10 = 5/8 in. (16 mm)

⁵TIG torch nozzles are typically made from alumina ceramic. Special applications may require lava nozzles, which are less prone to breakage, but cannot withstand high temperatures and high duty cycles.

VANTAGE 500 SETTINGS WHEN USING THE K799 HI-FREQ UNIT

- Set the WELD MODE switch to the 20-250 setting (TIG).
- Set the IDLER switch to the HIGH position.
- Set the WELDING TERMINALS switch to the WELD TERMINALS ON position. This will close the solid state contactor and provide an always “hot” electrode.

NOTE: This is necessary because the K799 circuitry with respect to the #2 and #4 leads does not provide the proper signal to open and close the solid state contactor in the Vantage 500.

VANTAGE 500 SETTINGS WHEN USING A K930-[] TIG MODULE

- Set the WELD MODE switch to the 20-250 setting (TIG).
- Set the IDLER switch to the AUTO position.
- Set the WELDING TERMINALS switch to the REMOTELY CONTROLLED position. This will keep the solid state contactor open and provide a “cold” electrode until the triggering device (Amptrol or Arc Start Switch) is pressed.

Return to Section TOC | Return to Master TOC

WIRE FEED (CONSTANT VOLTAGE) WELDING

Connect a wire feeder to the Vantage 500 and set welder controls according to the instructions listed earlier in this section. See the operator's manual for the wire feeder or the "**Diagrams**" section of this manual for connecting instructions of various Lincoln wire feeders.

The Vantage 500 in the CV-WIRE position can be used with a broad range of flux cored wire (Innershield and Outershield) electrodes and solid wires for MIG welding (GMAW). Welding can be finely tuned using the ARC CONTROL.

Some recommended Innershield electrodes are: NR-311, NS-3M, NR-207, NR-203 Ni 1%, NR-204-H.

Recommended Outershield electrodes are: 0S-70, 0S-71M.

Some recommended solid wires for MIG welding are: .035 (0.9 mm), .045 (1.1 mm) and .052 (1.3 mm), L-50 and L-56, .035 (0.9 mm) and .045 (1.1 mm) Blue Max MIG 308 LS.

For any electrodes, including the above recommendations, the procedures should be kept within the rating of the machine. For additional electrode information, see Lincoln publications N-675, GS-100 and GS-210.

ARC GOUGING

For optimal performance when arc gouging, set the Vantage 500 WELD MODE switch to the CC - STICK position, and the ARC CONTROL to 10.

Set the OUTPUT knob to adjust output current to the desired level for the gouging electrode being used according to the ratings in the following table:

TABLE B5.3

Electrode Diameter	Current Range (DC, electrode positive)
1/8"	30-60 Amps
5/32"	90-150 Amps
3/16"	150-200 Amps
1/4"	200-400 Amps
5/16"	250-400 Amps
3/8"	350-575 Amps*

* Maximum current setting is limited to the Vantage 500 maximum of 575 Amps.

PARALLELING

When paralleling machines in order to combine their outputs, all units must be operated in the CC - STICK mode only. To achieve this, turn the WELD MODE switch to the CC - STICK position. Operation in other modes may produce erratic outputs and large output imbalances between the units.

AUXILIARY POWER OPERATION

If a GFCI receptacle is tripped, See the MAINTENANCE section for detailed information on testing and resetting the GFCI receptacle.

Start the engine and set the IDLER control switch to the desired operating mode. Full power is available regardless of the welding control settings, if no welding current is being drawn.

The auxiliary power of the VANTAGE 500 CUMMINS consists of two 20 Amp-120VAC single phase (5-20R) GFCI duplex receptacles, one 50 Amp-120/240VAC single phase (14-50R) receptacle and one 50 Amp 240VAC three phase (15-50R) receptacle. The 120/240VAC receptacle can be split for single phase 120 VAC operation.

The auxiliary power capacity is 12,000 watts of 60 Hz, single phase power or 20,000 watts of 60Hz, three phase power. The auxiliary power capacity rating in watts is equivalent to volt-amperes at unity power factor. The maximum permissible current of the 240 VAC output is 50 A. The 240 VAC single phase output can be split to provide two separate 120 VAC outputs with a maximum permissible current of 50 A per output to two separate 120 VAC branch circuits. Output voltage is within $\pm 10\%$ at all loads up to rated capacity.

NOTE: The two 120V GFCI receptacles and the two 120V circuits of the 120/240V receptacle are connected to different phases and cannot be paralleled.

The auxiliary power receptacles should only be used with three wire grounded type plugs or approved double insulated tools with two wire plugs.

The current rating of any plug used with the system must be at least equal to the current capacity of the associated receptacle.

SIMULTANEOUS WELDING AND AUXILIARY POWER LOADS

It must be noted that the auxiliary power ratings are with no welding load.

Simultaneous welding and power loads are specified in table B5.4. The permissible currents shown assume that current is being drawn from either the 120 VAC or 240 VAC supply (not both at the same time).

**TABLE B.4 VANTAGE 500 CUMMINS
SIMULTANEOUS WELDING AND POWER LOADS**

WELD AMPS	PLUS	1 PHASE		OR	3 PHASE		OR	BOTH 1 AND 3 PHASE	
		WATTS	AMPS		WATTS	AMPS		WATTS	AMPS
0		12,000	50		20,000	50		-----	50
100		12,000	50		17,800	43		-----	50
200		12,000	50		14,000	34		-----	50
250		12,000	50		12,000	29		12,000	-----
300		10,000	42		10,000	24		10,000	-----
400		5,600	23		5,600	13		5,600	-----
500		0	0		0	0		0	0

**TABLE B5.5 VANTAGE 500 CUMMINS
Extension Cord Length Recommendations**

Current (Amps)	Voltage (Volts)	Load (Watts)	Maximum Allowable Cord Length in ft. (m) for Conductor Size											
			14 AWG		12 AWG		10 AWG		8 AWG		6 AWG		4 AWG	
	120	1800	30	(9)	40	(12)	75	(23)	125	(38)	175	(53)	300	(91)
15	240	3600	60	(18)	75	(23)	150	(46)	225	(69)	350	(107)	600	(183)
15	120	2400			30	(9)	50	(15)	88	(27)	138	(42)	225	(69)
20	240	4800			60	(18)	100	(30)	175	(53)	275	(84)	450	(137)
20	240	6000					90	(27)	150	(46)	225	(69)	250	(76)
25	240	7200					75	(23)	120	(37)	175	(53)	300	(91)
30	240	9000							100	(30)	150	(46)	250	(76)
38	240	12000									125	(38)	200	(61)
50														

Conductor size is based on maximum 2.0% voltage drop.

[Return to Section TOC](#) | [Return to Section TOC](#) | [Return to Section TOC](#) | [Return to Master TOC](#) | [Return to Master TOC](#) | [Return to Master TOC](#)

Return to Section TOC

Return to Section TOC

Return to Section TOC

Return to Section TOC

Return to Master TOC

Return to Master TOC

Return to Master TOC

Return to Master TOC

VANTAGE® 500



Accessories - VANTAGE® 500 Cummins B3.3 (Codes 11181 &11416)

Options/AccessoriesC5.1

 Optional Field Installed AccessoriesC5.2

 Plasma Cutting OptionC5.2

 TIG Welding OptionsC5.3

 High Frequency Generators for TIG ApplicationsC5.3

 Wire Feeder OptionsC5.3

Return to Master TOC

Return to Master TOC

Return to Master TOC

Return to Master TOC

OPTIONAL FIELD INSTALLED ACCESSORIES

K802N POWER PLUG KIT - Provides four 120V plugs rated at **20 amps** each and one dual voltage, full KVA plug rated at 120/240V, 50 amps. 120V plug may not be compatible with NEMA common household receptacles.

K802R POWER PLUG KIT - Provides four 120V plugs rated **15 amps** each and one dual voltage, full KVA plug rated at 120/240V, 50 amps, 120V plug is compatible with NEMA common household receptacles.

K857 25 ft. (7.5 m) or K857-1 100 ft. (30.4 m) REMOTE CONTROL - Portable control provides same dial range as the output control on the welder from a location up to the specified length from the welder. Has convenient plug for easy connection to the welder. The VANTAGE 500 CUMMINS is equipped with a 6-pin connector for connecting the remote control.

K704 ACCESSORY SET - Includes 35 feet (10 m) of electrode cable and 30 feet (9 m) of work cable, head-shield, Filter plate, work clamp and electrode holder. Cable is rated at 500 amps, 60% duty cycle.

K2641-2 FOUR WHEELED STEERABLE YARD TRAILER

For in plant and yard towing. Comes standard with a Duo-Hitch™, a 2" Ball and Lunette Eye combination hitch.

K2636-1 TRAILER - Two-wheeled trailer with optional fender and light package. For highway use, consult applicable federal, state, and local laws regarding possible additional requirements. Comes standard with a Duo-Hitch™, a 2" Ball and Lunette Eye combination hitch, a fender & a light package. **Order:**

K2636-1 Trailer

K958-1 Ball Hitch

K958-2 Lunette Eye Hitch

K2639-1 Fender & Light Kit

K2640-1 Cable Rack

K887-1 ETHER START KIT - Provides maximum cold weather starting assistance for frequent starting below 10°(-12°C). Required Ether tank is not provided with kit.

K899-1 SPARK ARRESTOR KIT - Easily mounts to standard muffler.

K949-1 Oil Drain Kit - includes ball valve, hose and clamp.

K1816-1 Full KVA Adapter Kit - Plugs into the 120/240V NEMA 14-50R receptacle on the case front (which accepts 4-prong plugs) and converts it to a NEMA 6-50R receptacle (which accepts 3-prong plugs) for connection to Lincoln Equipment with a NEMA 6-50P plug,

K1858-1 Service Indicator Kit - Provides a GO / NO-GO visual indication of air cleaner element useful service life. Filter service based on restriction readings allows the longest life possible from the filter and best engine protection. (Cannot be used with K887-1 Ether Start Kit at the same time.)

T12153-9 Full-KVA Power Plug-One dual voltage plug rated at 120/240V, 50 amps, single phase.

K2356-1 Control Panel Cover Kit-Clear plexiglass cover to protect control panel from dirt and debris, and to visually monitor machine operation. Lockable to deter vandalism.

K2340-1 Lockable Fuel Cap / Flash Arrester Kit-For use in locations where flash arrester safety is required. Lockable fuel cap prevents tampering with fuel. Green cap color provides a visual reminder to use diesel when refueling.

PLASMA CUTTING

K1581-1 Pro-cut 80 - Cuts mild steel using the 3-phase AC generator power from the engine driven welder.

NOTE: Other Linclon plasma cutters, both single phase and 3 phase can be used as long as the rating of the receptacle is not exceeded

⚠ WARNING

Pipe Thawing with an arc welder can cause fire, explosion, damage to electric wiring or to the arc welder if done improperly. The use of an arc welder for pipe thawing is not approved by the CSA, nor is it recommended or supported by Lincoln Electric.

TIG OPTIONS

K1783-9 PTA-26V TIG Torch

Air Cooled 200 amp torch (2 piece) equipped with valve for gas flow control. 25 ft. (7.6m) length.

KP509 Magnum Parts Kit for PTA-26V TIG Torch

Magnum Parts Kit provides all the torch accessories you need to start welding. Parts kit provides collets, collet bodies, a black cap, alumina nozzles and tungstens in a variety of sizes, all packaged in an easy to carry reclosable sack.

K870 Foot Amptrol®-Varies current while welding for making critical TIG welds and crater filling. Depress pedal to increase current. Depressing pedal fully achieves maximum set current. Fully raising the pedal finishes the weld and starts the after flow cycle on systems so equipped. Includes 25 ft. (7.6m) control cable.

K963-3 Hand Amptrol®-Varies current for making critical TIG welds. Fastens to the torch for convenient thumb control. Comes with a 25 ft. (7.6m) cable. (One size fits all Pro-Torch TIG Torches.)

K2347-1 Precision TIG 185 Ready-Pak

For AC TIG Welding with square wave performance use the AC generator of the Engine-Driven Welder to supply the power. Easy setup. Includes torch, foot amptrol, gas regulator and hose. Requires the K1816-1 Full KVA adapter kit.

K2350-1 Invertec® V205-T AC/DC One-Pak™ Package

For AC TIG welding with square wave performance, use the AC generator of the engine-driven welder to supply the power. Easy setup. Includes torch, parts kit, regulator and hose kit, Twist-Mate™ torch adapter, work cable with Twist-Mate end and foot Amptrol®.

HIGH FREQUENCY GENERATORS FOR TIG APPLICATIONS

The K799 Hi-Freq Unit and the K930- [] TIG Modules are suitable for use with the Vantage 500. The Vantage 500 is equipped with the required RF bypass circuitry for the connection of high frequency generating equipment. The high frequency bypass network supplied with the K799 Hi-Freq Unit does NOT need to be installed into the Vantage 500.

The Vantage 500 and any high frequency-generating equipment must be properly grounded. See the K799 Hi-Freq Unit and the K930-All TIG Module operating manuals for complete instructions on installation, operation, and maintenance.

WIRE FEEDER OPTIONS

K449 LN-25 Wire Feeder

Portable CC/CV unit for flux-cored and MIG welding. Includes Gas Solenoid & Internal Contactor.

K126-2 Magnum® 350 Innershield Gun (for LN-25)

For self-shielded wire with 15 ft. (4.5m) cable. For .062-3/32" (1.6-2.4mm) wire.

KP653-3/32 Drive Roll and Guide Tube Kit (for LN-25)
For .068-3/32" (1.8-2.4mm) cored or solid steel wire.

K1802-1 Magnum® 300 MIG Gun

For .035-.045 (0.9-1.2mm) gas shielded wire. Includes 15 ft. gun and cable assembly and connector kit.

KP653-035S Drive Roll and Guide Tube Kit (for LN-25)

For .035-.040" (0.9-1.0mm) solid steel wire.

K2613-1 LN-25 PRO PORTABLE WIRE FEEDER-The MAXTRAC® wire drive enhances performance, while the replacement case, and many other upgrade options that can be installed in less than five minutes aid in the serviceability.

KP1697-5/64 Drive Roll Kit- Includes: 2 polished U groove drive rolls, outer wire guide and inner wire guide for solid core wire. (Used on LN-25 Pro)

KP1697-068 Drive Roll Kit- Includes: 2 polished U groove drive rolls, outer wire guide and inner wire guide for solid core wire. (Used on LN-25 Pro)

KP1696-1 Drive Roll Kit- Includes: 2 V groove drive rolls and inner wire guide for Steel Wires. (Used on LN-25 Pro)

K487-25 Magnum SG Spool Gun

Hand held semiautomatic wire feeder. Requires SG Control Module and Input Cable.

K488 SG Control Module

The Interface between the power source and the spool gun. Provides control of the wire speed and gas flow. For use with a spool gun.

K691-10 Input Cable (For SG Control Module)

For Lincoln engine power sources with 14-pin MS-type connection, separate 115V NEMA receptacles and output stud connections.

OTHER WIRE FEEDERS USABLE WITH THE VANTAGE 500

- NA-3 or LT-7 Automatic Wire Feeder
- LN-742 Semi-automatic Wire Feeder
- LF-72/74 Semi-automatic Wire feeder
- LN-7 Semi-automatic Wire Feeder
- LN-8 Semi-automatic Wire Feeder
- LN-23P Semi-automatic Wire Feeder
- LN-15 Semi-automatic Wire Feeder

See the Wire Feeder Manual or the Diagrams section of this manual for connection information of the various feeders to the Vantage 500.

VANTAGE® 500



Return to Section TOC

Return to Section TOC

Return to Section TOC

Return to Section TOC

Return to Master TOC

Return to Master TOC

Return to Master TOC

Return to Master TOC

VANTAGE® 500



Return to Master TOC

Return to Master TOC

Return to Master TOC

Return to Master TOC

MAINTENANCE - VANTAGE 500 CUMMINS (CODE 11181 & 11416)

Safety Precautions D5.2

Routine Maintenance D5.2

Periodic Maintenance D5.2

 Change Oil D5.2

 Change Oil Filter D5.2

 Cooling System D5.3

 Drive Belt D5.3

 Fuel Filters D5.4

 Air Filter D5.5

Engine Maintenance Schedules and Parts D5.7

Welder/Generator Maintenance D5.7

 Storage D5.7

 Cleaning D5.7

 Nameplates D5.7

 Brush Removal and Replacement D5.7

 Bearings D5.7

 Receptacles D5.7

 Cable Connections D5.7

Battery Maintenance D5.8

 Cleaning the Battery D5.8

 Checking Specific Gravity D5.8

 Checking Electrolyte Level D5.8

 Charging the Battery D5.8

Major Component Locations D5.9

SAFETY PRECAUTIONS

WARNING

- Have qualified personnel do all maintenance and troubleshooting work.
- Turn the engine off before working inside the machine.
- Remove covers or guards only when necessary to perform maintenance and replace them when the maintenance requiring their removal is complete.
- If covers or guards are missing from the machine, get replacements from a Lincoln Distributor.

Read the Safety Precautions in the front of this manual and in the instruction manual for the diesel engine used with your machine before working on the Vantage 500.

Keep all equipment safety guards, covers, and devices in position and in good repair. Keep your hands, hair, clothing, and tools away from the fans, and all other moving parts when starting, operating, or repairing this machine.

ROUTINE AND PERIODIC MAINTENANCE

ENGINE MAINTENANCE

DAILY

- Check the crankcase oil level.
- Refill the fuel tank to minimize moisture condensation in the tank.
- Open the water drain valve located on the bottom of the water separator element one or two turns and allow to drain into a container suitable for diesel fuel for two to three seconds. Repeat the above drainage procedure until diesel fuel is detected in the container.
- Check the coolant level.

WEEKLY

Blow out the machine with low pressure air periodically. In particularly dirty locations, this may be required once a week.



CAUTION

To prevent the engine from accidentally starting, disconnect the negative battery cable before servicing the engine.

See the Service Plan section of the Engine Operation Manual for a summary of maintenance intervals for the items listed below. Follow either the hourly or the calendar intervals, whichever come first. More frequent service may be required, depending on your specific application and operating conditions.

OIL: Check the oil level after every 8 hours of operation or daily. **BE SURE TO MAINTAIN THE OIL LEVEL.**

Change the oil the first time between 25 and 50 hours of operation. Then, under normal operating conditions, change the oil as specified in Service Plan section of the Engine Operation Manual. If the engine is operated under heavy load or in high ambient temperatures, change the oil more frequently.

CHANGE THE OIL AND FILTER

CHANGE THE OIL: Change the oil, while the engine is still warm, as follows:

1. Route the Oil Drain hose through the access hole in the frame. Drain the oil using the ball valve on the lower right side of the engine. See **Figure D5.1**.
2. When the oil is drained, close the ball valve.
3. Remove the oil fill cap and pour in approximately 7.5 quarts (8 L) of oil. Check the dipstick and add oil until the level reaches the “H” mark. See **Figure D5.1**. Use high quality oil viscosity grade 10W40. Consult the engine manual for oil specifications for various ambient temperatures. Always check the level with the dipstick before adding more oil. Do not overfill.
4. Reinstall the oil fill cap and the dipstick.

CHANGE THE OIL FILTER: Change the oil filter the first time between 25 and 50 hours of operation. Then, under normal operating conditions, change the oil filter after every 250 hours of operation. If the engine is operated under heavy load or in high ambient temperatures, change the oil filter more frequently. See Service Plan section of the Engine Operation Manual for recommended maintenance intervals. See **Table D5.1** for replacement oil filters.

Change the oil filter as follows:

1. Drain the oil from the engine and allow the oil filter to drain. See **Figure D5.1**.
2. Remove the old filter (spin it off) and discard it. Wipe off the filter mounting surface and adapter. See **Figure D5.1**.

FIGURE D5.1 – ENGINE ASSEMBLY

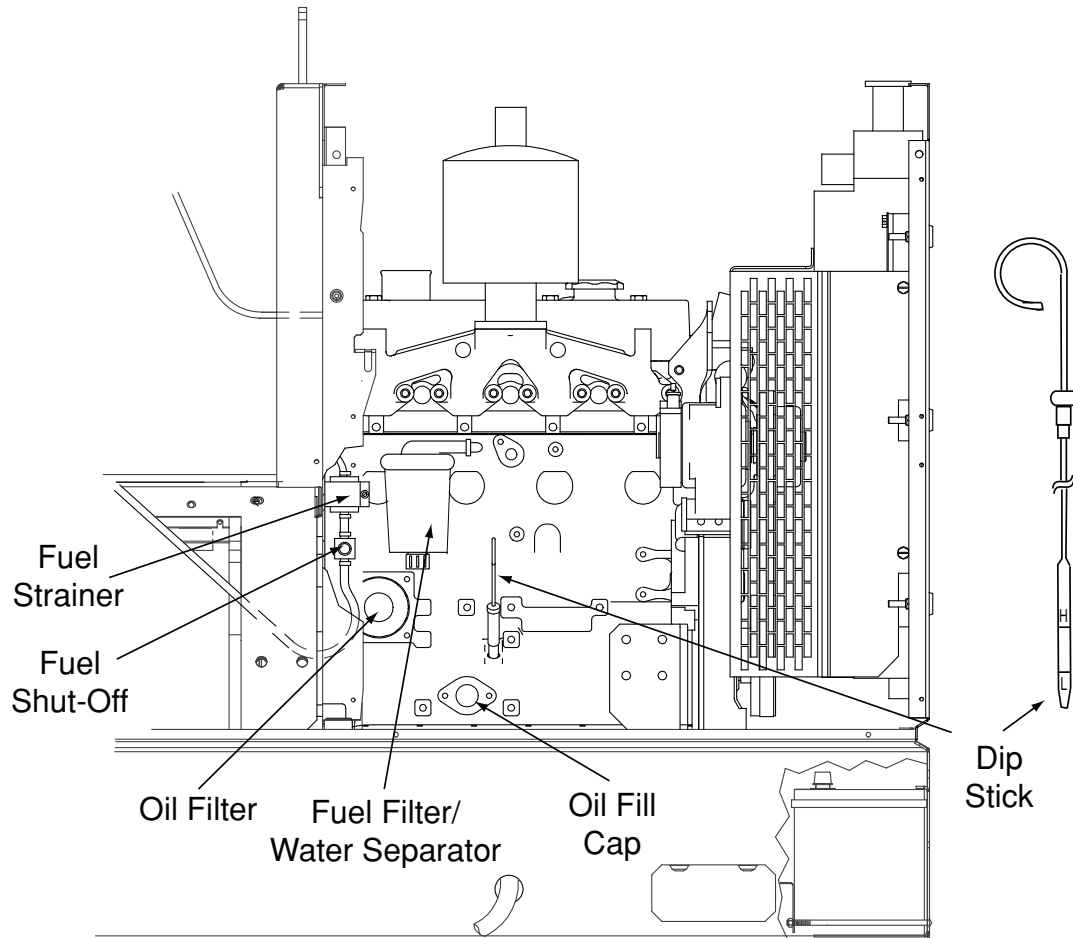

3. Apply a thin coat of new oil to the rubber gasket on the new oil filter.
4. Spin the new filter onto the mounting adapter finger tight until the gasket is evenly seated. Then turn it down another 1/2 turn. Do not overtighten the new filter.
5. Refill the engine with the proper amount and type of oil as described in the **Change the Oil** section. Start the engine and check for leaks around the filter element. Correct any leaks (usually by retightening the filter, but only enough to stop leaks) before placing the Vantage 500 back in service.
6. If there are no leaks, stop the engine and recheck the oil level. If necessary, add oil to bring the level up to the "MAX" mark, but do not overfill. See Figure D5.1.

FUEL: At the end of each day's use, refill the fuel tank to minimize moisture condensation and dirt contamination in the fuel line. Do not overfill; leave room for the fuel to expand.

Refer to your engine operation manual for recommended grade of fuel.

COOLING SYSTEM



WARNING

To avoid scalding, do not loosen or remove the radiator cap while the engine is hot.

The VANTAGE 500 Cummins is equipped with a pressurized radiator. Keep the radiator cap tight to avoid loss of coolant. Clean and flush the coolant system periodically to prevent clogging the passages and overheating the engine. See the Engine Manual for maintenance schedule.

If the coolant level is low, refill with a mixture of 50% water and 50% ethylene-glycol based antifreeze. See the Engine Manual for more information.

DRIVE BELT

Periodically check the Drive Belt tension and inspect the belt for cracks or other damage. See the Engine Manual for tension adjustment and/or belt replacement.

VANTAGE® 500



FUEL FILTERS

WARNING

When working on the fuel system



- Keep naked lights away, do not smoke !
- Do not spill fuel !

WARNING

Mechanical overtightening will distort the threads, filter element seal or filter can.

There is also a Fuel Strainer mounted just above the shut-off valve. See Figure D5.2. It is designed to prevent larger particle from entering the fuel system. There is no maintenance possible. If fuel flow seems restricted, replace the fuel strainer.

The VANTAGE 500 Cummins is equipped with a **Fuel Filter/Water Separator** located after the lift pump and before fuel injectors. The procedure for changing the filter is as follows. See Figure D4.2

1. Close the fuel shutoff valve.
2. Clean the area around the fuel filter head. Remove the filter. Clean the gasket surface of the filter head and replace the o-ring.
3. Fill the clean filter with clean fuel, and lubricate the o-ring seal with clean lubricating oil.
4. Install the filter as specified by the filter manufacturer.
5. Open the fuel valve and check for leaks.

FIGURE D5.2 - ENGINE ASSEMBLY

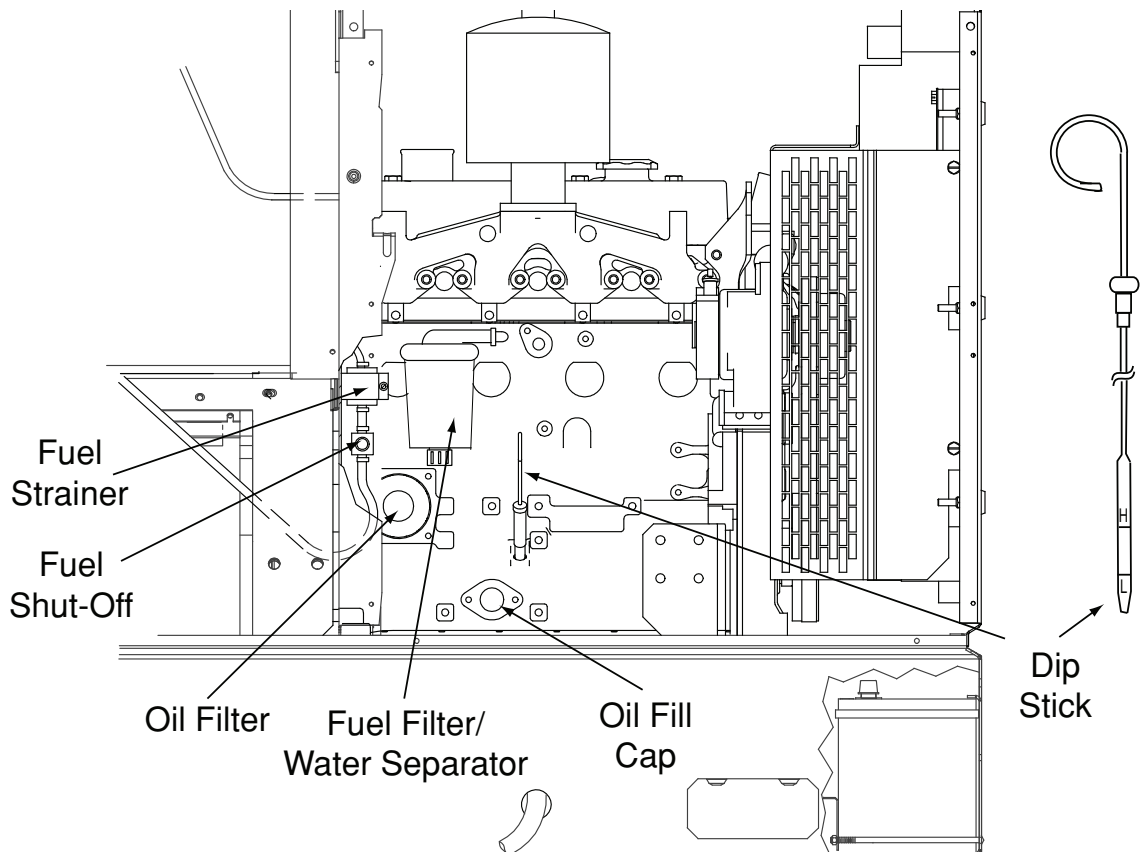

VANTAGE® 500

LINCOLN
ELECTRIC

AIR FILTER:

CAUTION

Excessive air filter restriction will result in reduced engine life.

The air filter element is a dry cartridge type. It can be cleaned and reused. However, damaged elements should not be reused. Stop engine after 100 hours of running time and clean filter element. Replace the filter if necessary. Service the air cleaner regularly according to your engine operation manual.

1. Locate the air filter canister located behind the engine door and mounted to the roof .
2. Remove the air filter element per the instructions on the **Maintenance Instructions** located on the door. (Also in this manual and the Operator's Manual
3. Remove loose dirt from the element with compressed air or a water hose directed from inside out.

Compressed Air: 100 psi maximum with nozzles at least one inch away from the element.

Water Hose: 40 psi maximum without nozzle.

4. Soak the element in a mild detergent solution for 15 minutes. Do not soak more than 24 hours. Swish the element around in the solution to help remove dirt.
5. Rinse elements from inside out with a gentle stream of water (less than 40 psi) to remove all suds and dirt.
6. Dry the element before reuse with warm air at less than 160°F (71°C). Do not use a light bulb to dry the element.
7. Inspect for holes and tears by looking through the element toward a bright light. Check for damaged gaskets or dented metal parts. Do not reuse damaged elements. Protect the element from dust and damage during drying and storage.
8. Reinstall the air filter element per the Maintenance Decal.

After six cleanings, replace the air filter. See the **Maintenance Instructions**. A cleaned filter will have approximately 70% of the life of a new filter element. A restricted filter element may not appear excessively dirty.

NOTE: If the entire cannister is removed or replaced, the spring clamps should be tightened to 15-20 in/lbs. See Figure D5.3

FIGURE D5.3 - AIR CLEANER

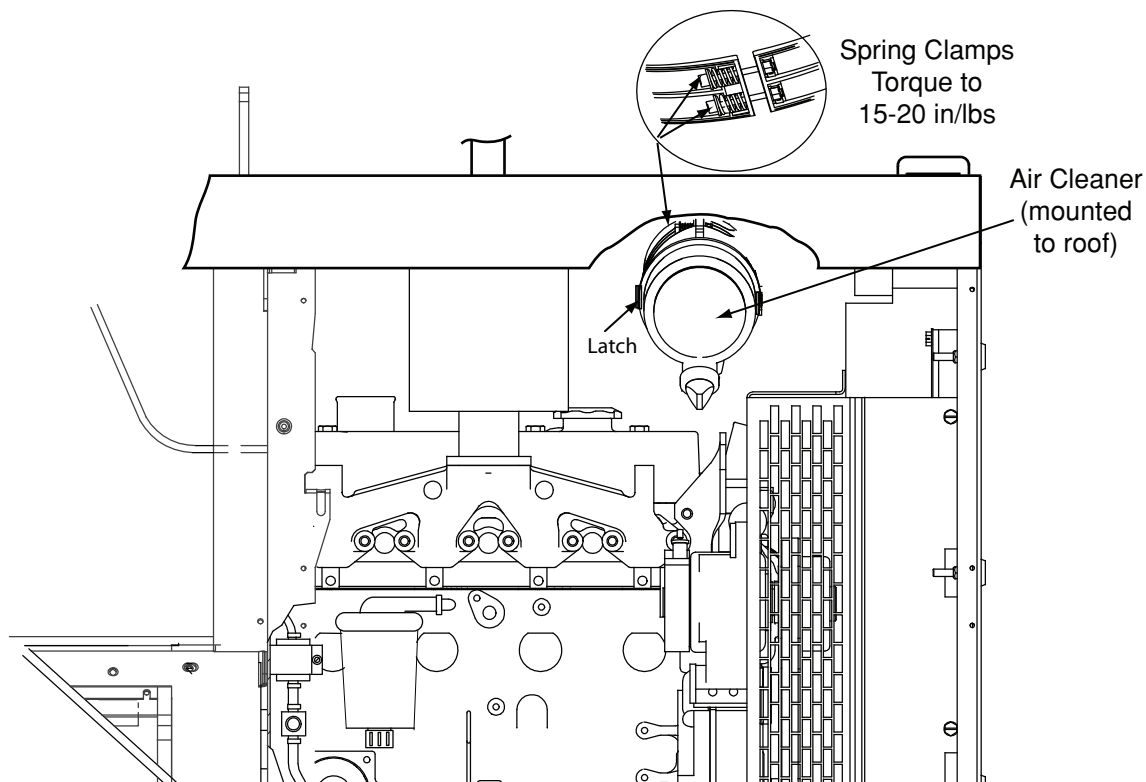

VANTAGE® 500

**LINCOLN®
ELECTRIC**

MAINTENANCE INSTRUCTIONS

Service Instructions

Single- and Two-Stage Engine Air Cleaners

1 Remove the Filter



Rotate the filter while pulling straight out.

Unfasten or unlatch the service cover. Because the filter fits tightly over the outlet tube to create the critical seal, there will be some initial resistance, similar to breaking the seal on a jar. Gently move the end of the filter back and forth to break the seal then rotate while pulling straight out. Avoid knocking the filter against the housing.

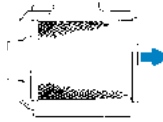

If your air cleaner has a safety filter, replace it every third primary filter change. Remove the safety filter as you would the primary filter. Make sure you cover the air cleaner outlet tube to avoid any unfiltered contaminant dropping into the engine.

2 Clean Both Surfaces of the Outlet Tube and Check the Vacuator™ Valve

Use a clean cloth to wipe the filter sealing surface and the inside of the outlet tube. Contaminant on the sealing surface could hinder an effective seal and cause leakage. Make sure that all contaminant is removed before the new filter is inserted. Dirt accidentally transferred to the inside of the outlet tube will reach the engine and cause wear. Engine manufacturers say that it takes only a few grams of dirt to "dust" an engine! Be careful not to damage the sealing area on the tube.

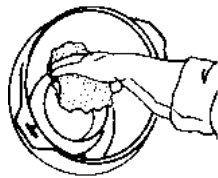

Outer edge of the outlet tube

Wipe both sides of the outlet tube clean.

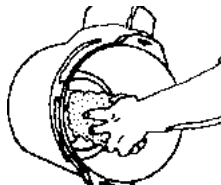

Inner edge of the outlet tube

If your air cleaner is equipped with a Vacuator Valve
Visually check and physically squeeze to make sure the valve is flexible and not inverted, damaged or plugged.



3 Inspect the Old Filter for Leak Clues

Visually inspect the old filter for any signs of leaks. A streak of dust on the clean side of the filter is a telltale sign. Remove any cause of leaks before installing new filter.

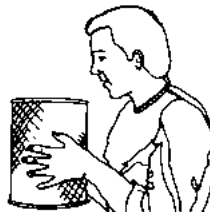

4 Inspect the New Filter for Damage

Inspect the new filter carefully, paying attention to the inside of the open end, which is the sealing area. NEVER install a damaged filter. A new Donaldson radial seal filter may have a dry lubricant on the seal to aid installation.

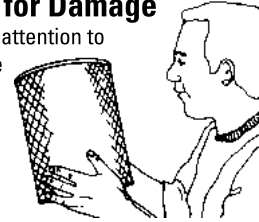

5 Insert the New Radial Seal Filter Properly

If you're servicing the safety filter, this should be seated into position before installing the primary filter.

Insert the new filter carefully. Seat the filter by hand, making certain it is completely into the air cleaner housing before securing the cover in place.



The critical sealing area will stretch slightly, adjust itself and distribute the sealing pressure evenly. To complete a tight seal, apply pressure by hand at the outer rim of the filter, not the flexible center. (Avoid pushing on the center of the urethane end cap.) No cover pressure is required to hold the seal. NEVER use the service cover to push the filter into place! Using the cover to push the filter in could cause damage to the housing, cover fasteners and will void the warranty.

If the service cover hits the filter before it is fully in place, remove the cover and push the filter (by hand) further into the air cleaner and try again. The cover should go on with no extra force.

Once the filter is in place, secure the service cover.



Caution

NEVER use the service cover to push the filter into place! Using the cover to push the filter in could cause damage to the housing, cover fasteners and will void the warranty.



6 Check Connectors for Tight Fit

Make sure that all mounting bands, clamps, bolts, and connections in the entire air cleaner system are tight. Check for holes in piping and repair if needed. Any leaks in your intake piping will send dust directly to the engine!

TABLE D5.1

Cummins B3.3 Engine Maintenance Components

ITEM	MAKE	PART NUMBER	SERVICE INTERVAL
Air Cleaner Element	Donaldson AC Fleetguard	P181052 A302C AF437K	Replace every 200 hours. (Replace more often when used in dusty and / or high ambient temperature conditions)
Oil Filer	Cummins Fleetguard	C6002112110 LF3855	Replace every 750 hours or 12 months, whichever is less.
Fan Belt	Cummins	C0412021748	Inspect every 1000 hours or 12 months, whichever is less.
Fuel Strainer	Cummins Fleetguard	3826094 FF5079	Inspect and replace monthly, as required. Replace annually.
Fuel Filter / Water Separator	Cummins Fleetguard	C6003112130 FS19594	Replace every 500 hours or 6 months, whichever is less.
Battery	-----	BCI GROUP 34	Inspect every 500 hours
Engine Oil Change	See Manual	-----	Change every 750 hours or 3 months, whichever is less. Check daily.

WELDER/GENERATOR MAINTENANCE

STORAGE: Store the Vantage 500 in clean, dry, protected areas.

CLEANING: Blow out the generator and controls periodically with low pressure air. Do this at least once a week in particularly dirty areas.

NAMEPLATES: Whenever routine maintenance is performed on this machine - or at least yearly - inspect all nameplates and labels for legibility. Replace those which are no longer clear. Refer to the parts list for the replacement item number.

BRUSH REMOVAL AND REPLACEMENT: It is normal for the brushes and slip rings to wear and darken slightly. Inspect the brushes when a generator overhaul is necessary.

WARNING

Do not attempt to polish slip rings while the engine is running.

BEARINGS: The Vantage 500 is equipped with double-shielded ball bearings having sufficient grease to last indefinitely under normal service. Where the welder is used constantly or in excessively dirty locations, it may be necessary to add one half ounce of grease per year. A pad of grease one inch wide, one inch long, and one inch high weighs approximately one half ounce. Over-greasing is far worse than insufficient greasing.

When greasing the bearings, keep all dirt out of the area. Wipe the fittings completely clean and use clean equipment. More bearing failures are caused by dirt introduced during greasing than from insufficient grease.

RECEPTACLES: Keep the electrical receptacles in good condition. Remove any dirt, oil, or other debris from their surfaces and holes.

CABLE CONNECTIONS: Check the welding cable connections at the weld output terminals often. Be sure that the connections are always tight.

VANTAGE® 500



BATTERY MAINTENANCE

WARNING



GASES FROM BATTERY can explode.

- Keep sparks, flame, and cigarettes away from battery.



BATTERY ACID can burn eyes and skin.

- Wear gloves and eye protection and be careful when working near a battery. Follow the instructions printed on the battery.

To prevent EXPLOSION when:

- **INSTALLING A NEW BATTERY** - Disconnect the negative cable from the old battery first and connect to the new battery last.
- **THE CORRECT POLARITY IS NEGATIVE GROUND** - Damage to the engine alternator and the printed circuit board can result from incorrect connection.



• **CONNECTING A BATTERY CHARGER**

- Remove the battery from the welder by disconnecting the negative cable first, then the positive cable and battery clamp. When reinstalling, connect the negative cable last. Keep the area well ventilated.

- **USING A BOOSTER** - Connect the positive lead to the battery first, then connect the negative lead to the engine foot.
- To prevent BATTERY BUCKLING, tighten the nuts on the battery clamp until snug.

CLEANING THE BATTERY: Keep the battery clean by wiping it with a damp cloth when dirty. If the terminals appear corroded, disconnect the battery cables and wash the terminals with an ammonia solution or a solution of 1/4 pound (0.113 kg) of baking soda and 1 quart (0.946 l) of water. Be sure the battery vent plugs (if equipped) are tight so that none of the solution enters the cells.

After cleaning, flush the outside of the battery, the battery compartment, and surrounding areas with clear water. Coat the battery terminals lightly with petroleum jelly or a non-conductive grease to retard corrosion.

Keep the battery clean and dry. Moisture accumulation on the battery can lead to more rapid discharge and early battery failure.

CHECKING SPECIFIC GRAVITY: Check each battery cell with a hydrometer. A fully charged battery will have a specific gravity of 1.260. Charge the battery if the reading is below 1.215.

NOTE: Correct the specific gravity reading by adding four gravity points (0.004) for every five degrees the electrolyte temperature is above 80 degrees F (27 degrees C). Subtract four gravity points (.004) for every five degrees the electrolyte temperature is below 80 degrees F (27 degrees C).

CHECKING ELECTROLYTE LEVEL: If battery cells are low, fill them to the neck of the filler hole with distilled water and recharge. If one cell is low, check for leaks.

CHARGING THE BATTERY: The Vantage 500 is equipped with a wet charged battery. The charging current is automatically regulated when the battery is low (after starting the engine) to a trickle current when the battery is fully charged.

When you charge, jump, replace, or otherwise connect battery cables to the battery, be sure the polarity is correct. Improper polarity can damage the charging circuit. **The Vantage 500 charging system is NEGATIVE GROUND.** The positive (+) battery terminal has a red terminal cover.

If you need to charge the battery with an external charger, disconnect the negative cable first, then the positive cable before you attach the charger leads. After the battery is charged, reconnect the positive battery cable first and the negative cable last. Failure to do so can result in damage to the internal charger components.

Follow the instructions of the battery charger manufacturer for proper charger settings and charging time.

FIGURE D5.4 – MAJOR COMPONENT LOCATIONS

- | | |
|----------------------------------|------------------------|
| 1. CONTROL PANEL ASSEMBLY | 6A. ENGINE ASSEMBLY |
| 2. CONTROL BOX & OUTPUT ASSEMBLY | 7. GENERATOR FRAME |
| 3. POWER MODULE ASSEMBLY | 8. SOLENOID ASSEMBLY |
| 4. BASE & LIFT BALE ASSEMBLY | 9. CASEBACK |
| 5. FUEL TANK & MOUNTING | 10. CASE TOP AND SIDES |

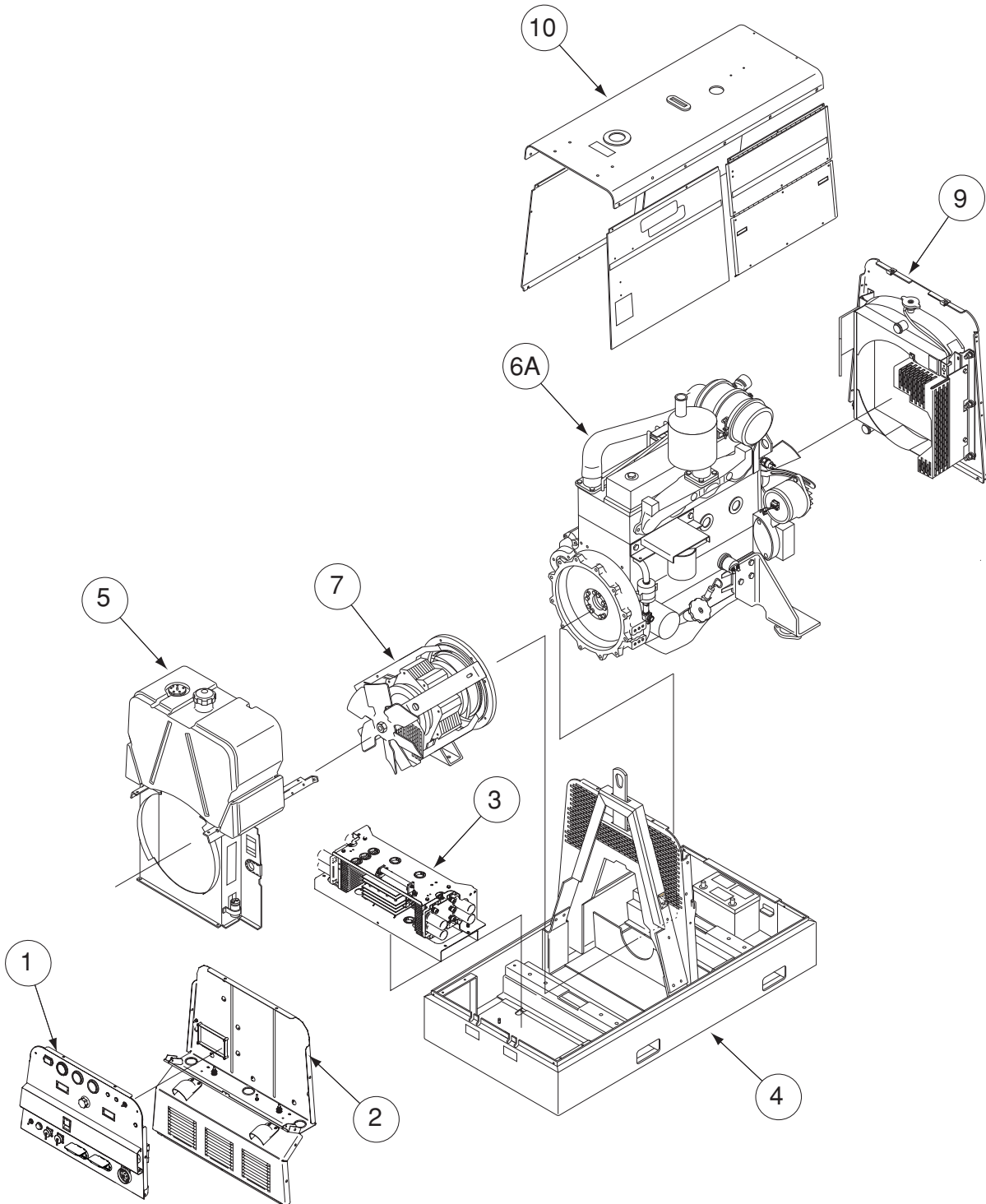

VANTAGE® 500

Return to Section TOC

Return to Section TOC

Return to Section TOC

Return to Section TOC

Return to Master TOC

Return to Master TOC

Return to Master TOC

Return to Master TOC

VANTAGE® 500



Return to Master TOC

Return to Master TOC

Return to Master TOC

Return to Master TOC

Theory of OperationE-1

General DescriptionE-2

Battery, Starter, Engine, Rotor, Stator, Pull Coil Board and Peripheral Board – Engine ProtectionE-2

Weld Windings, Rectifier, Power Modules and FeedbackE-3

Weld Control BoardE-4

Insulated Gate Bipolar Transistor (IGBT) OperationE-5

Pulse Width ModulationE-6

Chopper Technology FundamentalsE-7

FIGURE E.1 BLOCK LOGIC DIAGRAM

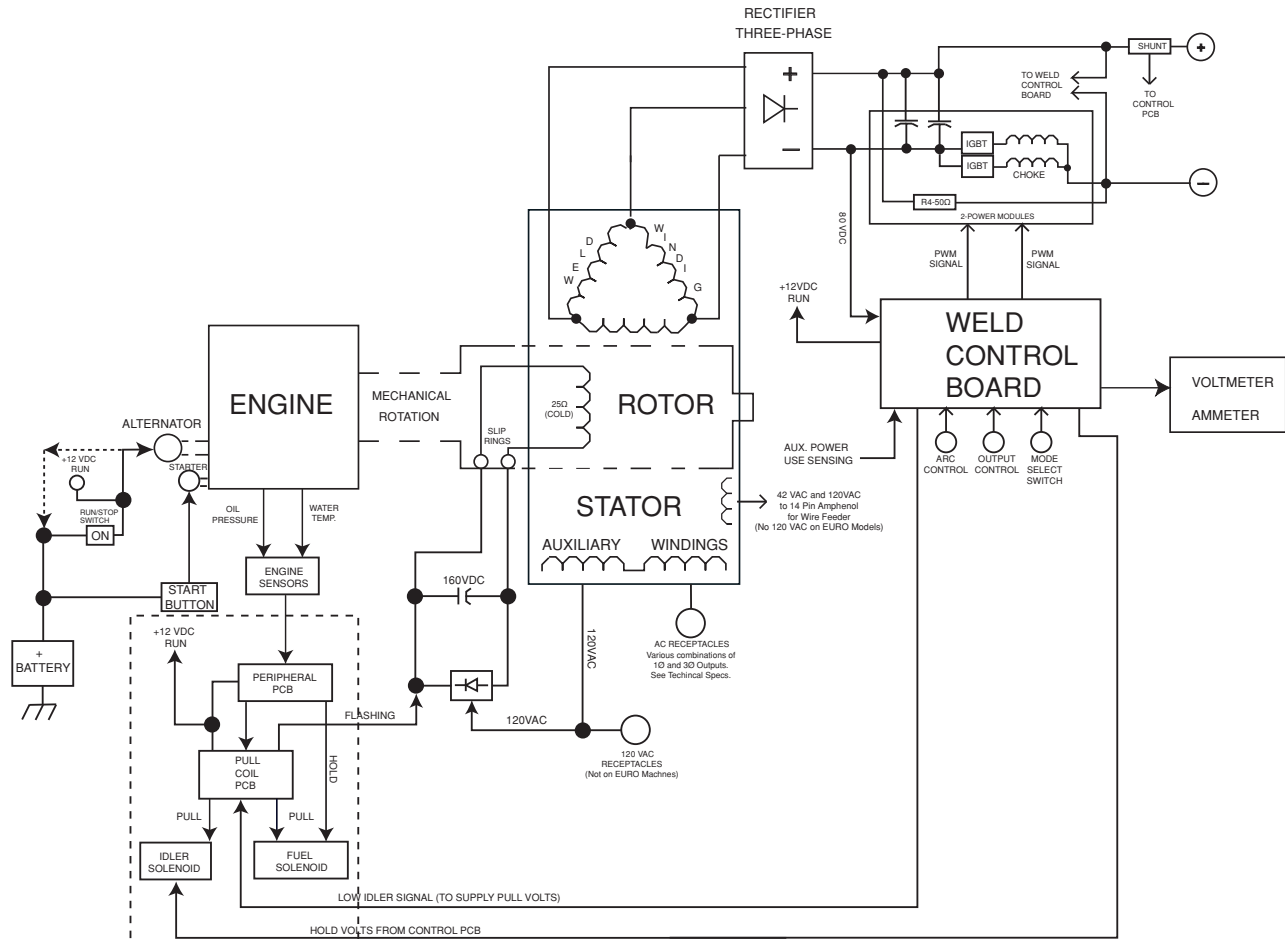

* On some codes the Peripheral Board, Pull Coil Board, Idler Solenoid & Fuel Solenoid are replaced by an Electronic Governor Control module and components. See Wiring Diagram.

FIGURE E.2 - BATTERY, ENGINE, ROTOR, PULL COIL BOARD AND PERIPHERAL BOARD (ENGINE PROTECTION

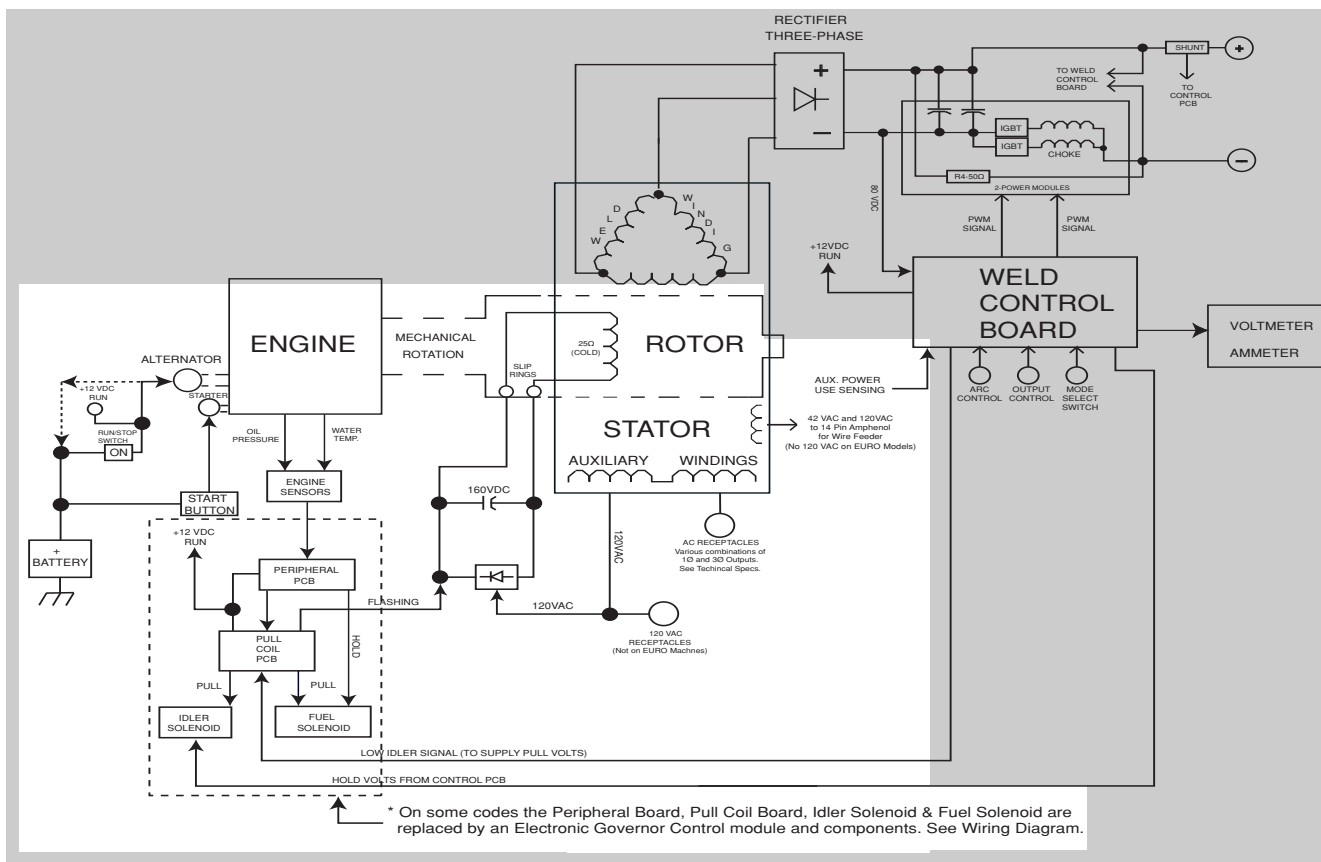

GENERAL DESCRIPTION

The Vantage 500 is a diesel engine-driven welding power source capable of producing 500 amps at 40VDC at a 100% duty cycle. The engine is coupled to a brush-type alternating current generator. This AC output is rectified and controlled by **Chopper Technology** to produce DC current for multi-purpose welding applications. The Vantage 500 also provides auxiliary power of various voltage and wattage levels depending on the Code number. See the appropriate Wiring Diagram or Technical Specifications.

BATTERY, ENGINE, ROTOR, STATOR, PULL COIL BOARD AND PERIPHERAL BOARD – ENGINE PROTECTION

The 12VDC battery powers the engine starter motor and also supplies power to the Pull Coil PC board, Peripheral PC board and associated circuitry. When the engine, which is mechanically coupled to the rotor, is started and running, the 12 VDC battery voltage is fed momentarily through the pull coil PC board to the rotor field coil via a brush and slip ring configuration.

This excitation or "flashing" voltage magnetizes the rotor lamination. This rotating magnet induces a voltage in the stationary windings of the main alternator stator. A 120VAC supply from the stator is fed through a rectifier and filter to supply the rotor with a steady DC voltage. The stator also houses a three-phase weld winding, a 120/240VAC single-phase auxiliary winding. In some codes, there is also a 3 phase auxiliary and a separate 120VAC and/or a 42VAC wire feeder power supply that is routed to the 14 pin MS type Connector.

The engine alternator supplies charging current for the battery circuit. The Peripheral board monitors the engine sensors and will shut the engine off in the event of low oil pressure, engine over temperature, malfunction of the engine's alternator system or a low fuel condition. The idler solenoid, if present, is mechanically connected to the engine's throttle linkage. If no welding or auxiliary current is being drawn from the Vantage 500, the Pull Coil board activates the idler solenoid, which then brings the engine to a low idle state. When output current is sensed (either weld or auxiliary), the Weld Control PC board deactivates the idler solenoid, and the engine goes to high RPM.

NOTE: Unshaded areas of Block Logic Diagram are the subject of discussion

VANTAGE® 500

LINCOLN
ELECTRIC

FIGURE E.3 - WELD WINDINGS, RECTIFIER, POWER MODULES AND FEEDBACK

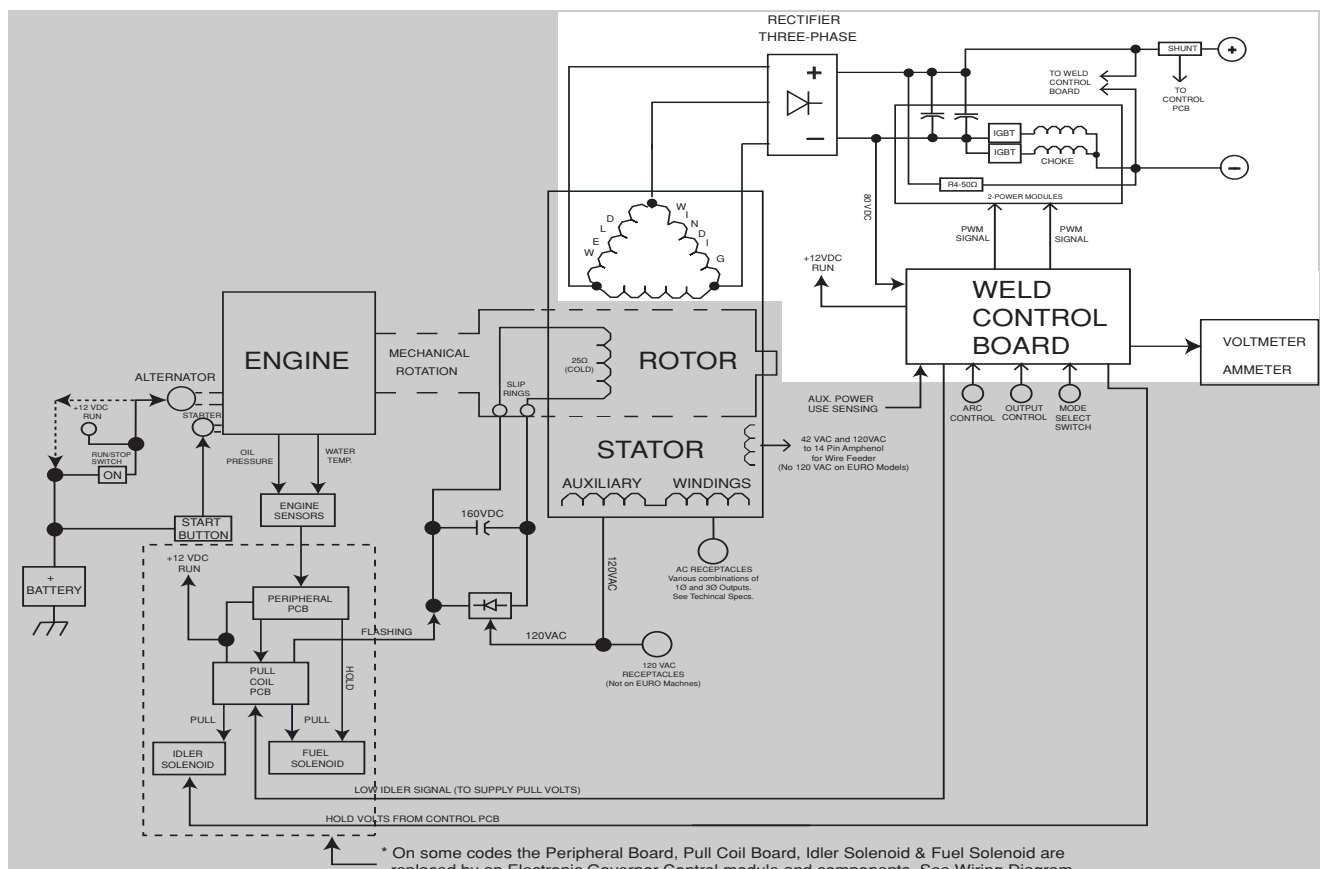

WELD WINDINGS, RECTIFIER, POWER MODULES AND FEEDBACK

The three-phase stator weld windings are connected to a three-phase rectifier bridge. The resultant DC voltage is applied to four paralleled capacitors incorporated within each of the two power modules. There are two capacitors in each module. These capacitors function as filters and also as power supplies for the IGBTs. See **IGBT Operation** in this section. The IGBTs act as high-speed switches operating at 20KHZ. These devices are switched on and off by the Weld Control PC board through pulse width modulation circuitry. See **Pulse Width Modulation** discussion in this section.

This chopped" DC output is applied through choke coils and a shunt to the welding output terminals. The choke functions as a current filter, and it helps to balance the outputs of the two power modules. Free-wheeling diodes are incorporated in the power modules to provide a current path for the stored energy in the choke when the IGBTs are turned off. See the **Chopper Technology** discussion in this section.

Output voltage feedback from the output terminals and current feedback from the shunt is fed to the Weld Control PC board as a means of controlling the output.

NOTE: Unshaded areas of Block Logic Diagram are the subject of discussion

VANTAGE® 500

LINCOLN®
ELECTRIC

FIGURE E.4 - POWER MODULES AND WELD CONTROL BOARD

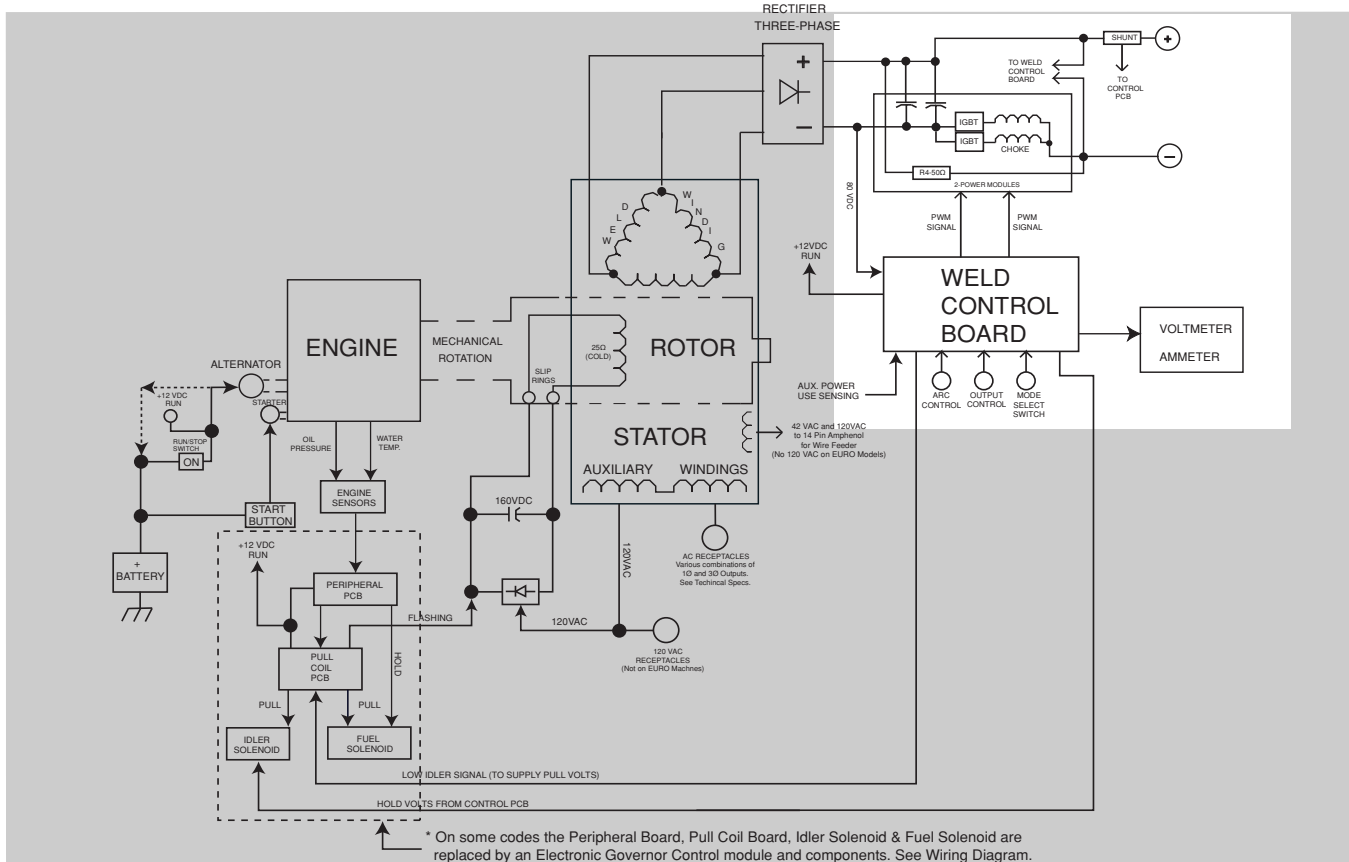

WELD CONTROL BOARD

The 80 VDC derived from the filter capacitors on the Power Modules, supplies various regulated DC voltages to operate the Weld Control PC board circuitry. It also supplies two regulated DC voltages to operate the IGBT driver circuitry on the two Power Modules.

The Weld Control PC board monitors the operator controls (arc control, output, and process/range selector). It compares these commands to the current and voltage feedback information it receives from the shunt and output terminal circuits.

The circuitry on the Weld Control PC board determines how the output should be controlled to optimize welding results, and it sends the correct PWM signals to the IGBT driver circuits. The Weld Control PC board also commands the thermal light and the voltmeter and ammeter (some items may be optional).

NOTE: Unshaded areas of Block Logic Diagram are the subject of discussion

VANTAGE® 500

LINCOLN
ELECTRIC

FIGURE E.5 – IGBT OPERATION

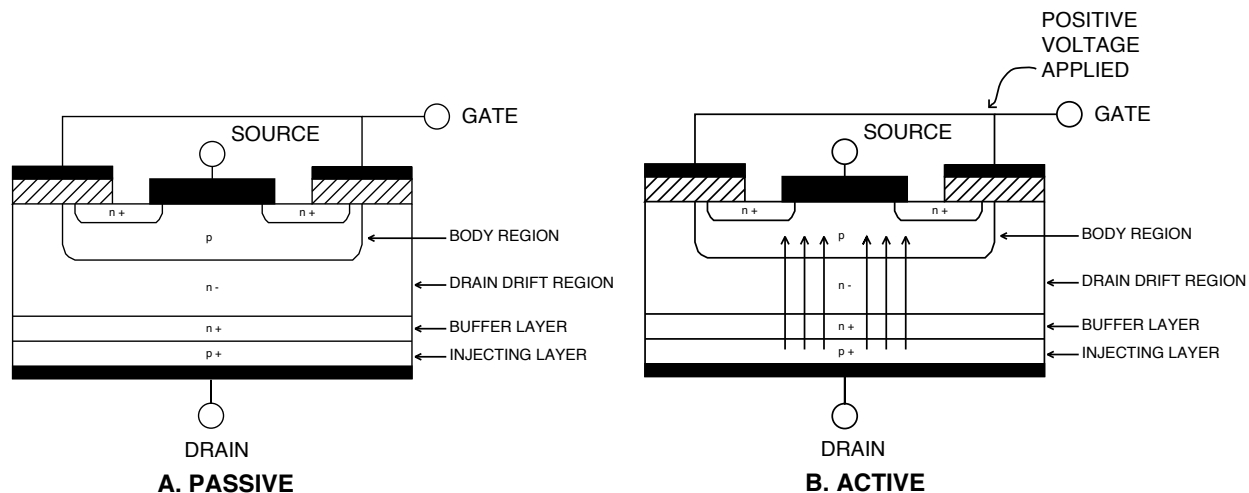

INSULATED GATE BIPOLAR TRANSISTOR (IGBT) OPERATION

An IGBT is a type of transistor. IGBTs are semiconductors well suited for high frequency switching and high current applications.

Drawing A in Figure E.5 shows an IGBT in a passive mode. There is no gate signal, zero volts relative to the source, and therefore, no current flow. The drain terminal of the IGBT may be connected to a voltage supply; but since there is no conduction the circuit will not supply current to components connected to the source. The circuit is turned off like a light switch in the OFF position.

Drawing B shows the IGBT in an active mode. When the gate signal, a positive DC voltage relative to the source, is applied to the gate terminal of the IGBT, the device is capable of conducting current. A voltage supply connected to the drain terminal will allow the IGBT to conduct and supply current to circuit components coupled to the source. Current will flow through the conducting IGBT to downstream components as long as the positive gate signal is present. This is similar to turning ON a light switch.

FIGURE E.6 – TYPICAL IGBT OUTPUTS

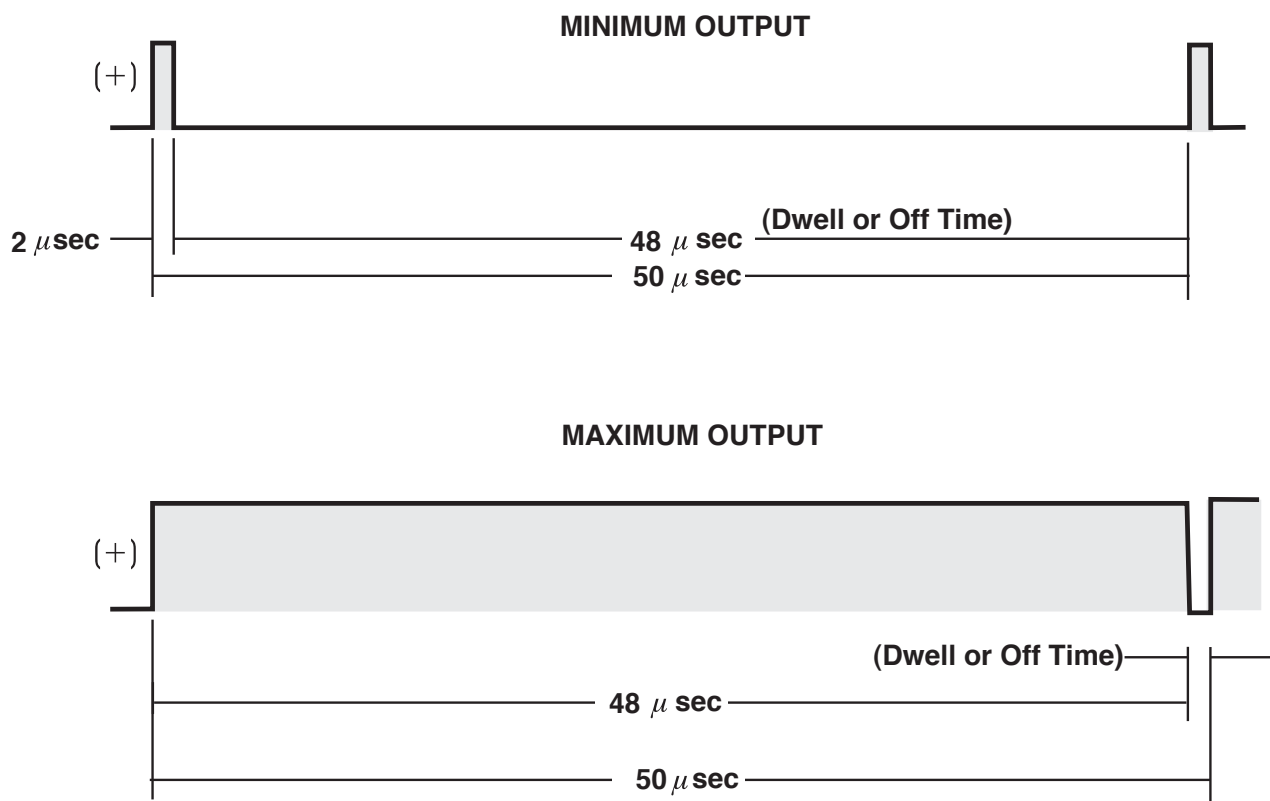

PULSE WIDTH MODULATION

The term PULSE WIDTH MODULATION is used to describe how much time is devoted to conduction in the cycle. Changing the pulse width is known as MODULATION. Pulse Width Modulation (PWM) is the varying of the pulse width over the allowed range of a cycle to affect the output of the machine.

MINIMUM OUTPUT

By controlling the duration of the gate signal, the IGBT is turned on and off for different durations during a cycle. The top drawing shows the minimum output signal possible over a 50-microsecond time period.

The positive portion of the signal represents one IGBT group conducting for 2 microsecond. The dwell time (off time) is 48 microseconds. Since only 2 microseconds of the 50-microsecond time period is devoted to conducting, the output power is minimized.

MAXIMUM OUTPUT

By holding the gate signals on for 48 microseconds and allowing only 2 microseconds of dwell time (off time) during the 50-microsecond cycle, the output is maximized. The darkened area under the top curve can be compared to the area under the bottom curve. The more darkened area under the curve, the more power is present.

CHOPPER TECHNOLOGY FUNDAMENTALS

The new era of welding machines such as the Vantage 500, employ a technology whereby a DC source is turned on and off (chopped up) at high speed, then smoothed through an inductor to control an arc.

Hence the name “Chopper.” The biggest advantage of chopper technology is the high-speed control of the arc, similar to the inverter machines. A block diagram for this is as follows:

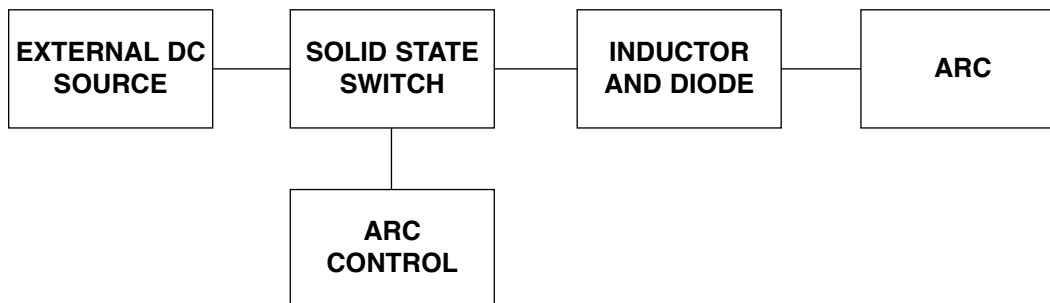

In this system, the engine drives a three-phase alternator, which generates power that is rectified and filtered to produce about 80VDC. The current is applied through a solid state switch (IGBT) to an inductor. By

turning the switch on and off, current in the inductor and the arc can be controlled. The following diagram depicts the current flow in the system when the switch is open and closed.

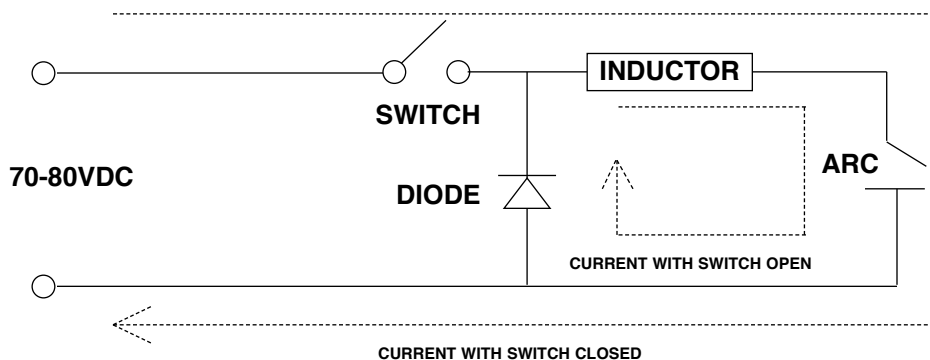

When the switch is closed, current is applied through the inductor to the arc. When the switch opens, current stored in the inductor sustains flow in the arc and through the diode. The repetition rate of switch closure is 20Khz, which allows ultra-fast control of the arc. By

varying the ratio of on time versus off time of the switch (Duty Cycle), the current applied to the arc is controlled. This is the basis for Chopper Technology: Controlling the switch in such a way as to produce superior welding.

Return to Section TOC

Return to Section TOC

Return to Section TOC

Return to Section TOC

Return to Master TOC

Return to Master TOC

Return to Master TOC

Return to Master TOC

VANTAGE® 500



Return to Master TOC

Return to Master TOC

Return to Master TOC

Return to Master TOC

Troubleshooting and RepairF-1

 How to Use Troubleshooting GuideF-2

 PC Board Troubleshooting ProceduresF-3

 Troubleshooting GuideF-4

 Test ProceduresF-13

 Case Cover Removal and Replacement ProcedureF-13

 Chopper Module Capacitor Discharge ProcedureF-15

 Chopper Module Resistance Test ProcedureF-17

 Idler Solenoid TestF-21

 Shutdown Solenoid TestF-23

 Engine Throttle Adjustment TestF-25

 Rotor Resistance TestF-29

 Flashing and Rotor Voltage TestF-31

 Stator Voltage TestF-33

 Output Rectifier Bridge TestF-37

 Electronic Governor TestF-43

 Charging Circuit TestF-45

 Oscilloscope WaveformsF-47

 Normal Open Circuit Voltage Waveform (115VAC Supply)F-47

 Normal Open Circuit Voltage Waveform (Stick)F-48

 Normal Weld Voltage Waveform (Stick CC)F-49

 Normal Weld Voltage Waveform (Wire CV)F-50

 Normal TIG Mode Voltage WaveformF-51

 Normal Open Circuit Voltage Waveform (Wire CV Tap)F-52

 Replacement ProceduresF-53

 Shutdown Solenoid Removal and ReplacementF-53

 Output Rectifier Bridge Removal and ReplacementF-57

 Stator/Rotor Removal and ReplacementF-59

 Retest After RepairF-68

HOW TO USE TROUBLESHOOTING GUIDE

⚠ WARNING

Service and Repair should only be performed by Lincoln Electric Factory Trained Personnel. Unauthorized repairs performed on this equipment may result in danger to the technician and machine operator and will invalidate your factory warranty. For your safety and to avoid Electrical Shock, please observe all safety notes and precautions detailed throughout this manual.

This Troubleshooting Guide is provided to help you locate and repair possible machine malfunctions. Simply follow the three-step procedure listed below.

Step 1. LOCATE PROBLEM (SYMPTOM).

Look under the column labeled "PROBLEM (SYMPTOMS)". This column describes possible symptoms that the machine may exhibit. Find the listing that best describes the symptom that the machine is exhibiting. Symptoms are grouped into the following categories: output problems, function problems, wire feeding problems, and welding problems.

Step 2. PERFORM EXTERNAL TESTS.

The second column labeled "POSSIBLE AREAS OF MISADJUSTMENT(S)" lists the obvious external possibilities that may contribute to the machine symptom. Perform these tests/checks in the order listed. In general, these tests can be conducted without removing the case wrap-around cover.

Step 3. RECOMMENDED COURSE OF ACTION

The last column labeled "Recommended Course of Action" lists the most likely components that may have failed in your machine. It also specifies the appropriate test procedure to verify that the subject component is either good or bad. If there are a number of possible components, check the components in the order listed to eliminate one possibility at a time until you locate the cause of your problem.

All of the referenced test procedures referred to in the Troubleshooting Guide are described in detail at the end of this chapter. Refer to the Troubleshooting and Repair Table of Contents to locate each specific Test Procedure. All of the specified test points, components, terminal strips, etc. can be found on the referenced electrical wiring diagrams and schematics. Refer to the Electrical Diagrams Section Table of Contents to locate the appropriate diagram.

⚠ CAUTION

If for any reason you do not understand the test procedures or are unable to perform the tests/repairs safely, contact the Lincoln Electric Service Department for technical troubleshooting assistance before you proceed. Call 1-888-935-3877.

PC BOARD TROUBLESHOOTING PROCEDURES

⚠ WARNING**ELECTRIC SHOCK
can kill.**

- Have an electrician install and service this equipment. Turn the input power OFF at the fuse box before working on equipment. Do not touch electrically hot parts.

⚠ CAUTION

Sometimes machine failures appear to be due to PC board failures. These problems can sometimes be traced to poor electrical connections. To avoid problems when troubleshooting and replacing PC boards, please use the following procedure:

1. Determine to the best of your technical ability that the PC board is the most likely component causing the failure symptom.
2. Check for loose connections at the PC board to assure that the PC board is properly connected.
3. If the problem persists, replace the suspect PC board using standard practices to avoid static electrical damage and electrical shock. Read the warning inside the static resistant bag and perform the following procedures:

PC board can be damaged by static electricity.

**ATTENTION
Static-Sensitive
Devices
Handle only at
Static-Safe
Workstations**

- Remove your body's static charge before opening the static-shielding bag. Wear an anti-static wrist strap. For safety, use a 1 Meg ohm resistive cord connected to a grounded part of the equipment frame.

- If you don't have a wrist strap, touch an un-painted, grounded, part of the equipment frame. Keep touching the frame to prevent static build-up. Be sure not to touch any electrically live parts at the same time.

- Tools which come in contact with the PC board must be either conductive, anti-static or static-dissipative.

- Remove the PC board from the static-shielding bag and place it directly into the equipment. Don't set the PC board on or near paper, plastic or cloth which could have a static charge. If the PC board can't be installed immediately, put it back in the static-shielding bag.

- If the PC board uses protective shorting jumpers, don't remove them until installation is complete.

- If you return a PC board to The Lincoln Electric Company for credit, it must be in the static-shielding bag. This will prevent further damage and allow proper failure analysis.

4. Test the machine to determine if the failure symptom has been corrected by the replacement PC board.

NOTE: It is desirable to have a spare (known good) PC board available for PC board troubleshooting.

NOTE: Allow the machine to heat up so that all electrical components can reach their operating temperature.

5. Remove the replacement PC board and substitute it with the original PC board to recreate the original problem.

- a. If the original problem does not reappear by substituting the original board, then the PC board was not the problem. Continue to look for bad connections in the control wiring harness, junction blocks, and terminal strips.

- b. If the original problem is recreated by the substitution of the original board, then the PC board was the problem. Reinstall the replacement PC board and test the machine.

6. Always indicate that this procedure was followed when warranty reports are to be submitted.

NOTE: Following this procedure and writing on the warranty report, "INSTALLED AND SWITCHED PC BOARDS TO VERIFY PROBLEM," will help avoid denial of legitimate PC board warranty claims.

Observe Safety Guidelines detailed in the beginning of this manual.

PROBLEMS (SYMPTOMS)	POSSIBLE AREAS OF MISADJUSTMENT(S)	RECOMMENDED COURSE OF ACTION
OUTPUT PROBLEMS		
Major physical or electrical damage is evident.	1. Contact your local Lincoln Authorized Field Service Facility.	1. Contact the Lincoln Electric Service Department at 1-888-935-3877.
No welding output in neither Stick or CV modes. The engine operates normally. The auxiliary output is normal	<ol style="list-style-type: none"> 1. Place the Welding Terminals Switch in the "ALWAYS ON" position. If the problem is solved, the fault may be in the external control cable (if used), leads #2 and #4. See the Wiring Diagram. 2. With the engine at high idle (1900RPM), the machine in the Stick mode and the OUTPUT CONTROL at maximum, check for the presence of approximately 87VDC (open circuit voltage) at the output terminals. 3. If the correct OCV is present at the welding output terminals check the welding cables, clamps and electrode holder for loose or faulty connections. 	<ol style="list-style-type: none"> 1. Check for loose or faulty connections on the heavy current carrying leads between the output bridge, the power modules, the choke and the output terminals. 2. Check the Welding Terminals Switch and associated leads. See the Wiring Diagram. 3. Check gate leads #23, #23A, #25 and #25A for loose or faulty connections. See the Wiring Diagram. 4. Perform the Stator Voltage Test. 5. Perform the Output Rectifier Bridge Test. 6. Perform the Chopper Module Test. 7. The Weld Control PC Board may be faulty.

⚠ CAUTION

If for any reason you do not understand the test procedures or are unable to perform the tests/repairs safely, contact the Lincoln Electric Service Department for technical troubleshooting assistance before you proceed. Call 1-888-935-3877.

Return to Section TOC

Return to Section TOC

Return to Section TOC

Return to Section TOC

Return to Master TOC

Return to Master TOC

Return to Master TOC

Return to Master TOC

Observe Safety Guidelines detailed in the beginning of this manual.

PROBLEMS (SYMPTOMS)	POSSIBLE AREAS OF MISADJUSTMENT(S)	RECOMMENDED COURSE OF ACTION
OUTPUT PROBLEMS		
<p>No welding output in either Stick or CV modes. Also no auxiliary power. The engine operates normally.</p>	<ol style="list-style-type: none"> 1. Check the brushes for wear and proper contact to the rotor slip rings. 2. Make sure the engine is operating at the correct high idle speed (1900RPM). 3. Check for loose or faulty connections or leads on the auxiliary power studs in the control box. See the Wiring Diagram. 	<ol style="list-style-type: none"> 1. Perform the Rotor Resistance Test. 2. Perform the Flashing and Rotor Voltage Test. If the "flashing" voltage is not present the leads 6,5H,200B, #201 or #200 may be faulty. See the Wiring Diagram. Also make sure that lead #5P has continuity (zero ohms) to ground. 3. Check the field diode bridge and capacitor. Replace if necessary. 4. Perform the Stator Voltage Test.
<p>No auxiliary power at the receptacles. The welding output is normal and the engine operates normally.</p>	<ol style="list-style-type: none"> 1. The circuit breakers may be tripped. Reset if necessary. 2. Check for loose or faulty connections at the auxiliary receptacles. 	<ol style="list-style-type: none"> 1. Check the wiring between the auxiliary receptacles, the connection studs in the control box, and the main stator. See the Wiring Diagram. 2. Perform the Stator Voltage Test. 3. Check GFCI receptacles. <p>NOTE: The machine must be at high idle to reset the GFCI receptacles</p>

⚠ CAUTION

If for any reason you do not understand the test procedures or are unable to perform the tests/repairs safely, contact the Lincoln Electric Service Department for technical troubleshooting assistance before you proceed. Call 1-888-935-3877.

VANTAGE® 500



Observe Safety Guidelines detailed in the beginning of this manual.

PROBLEMS (SYMPTOMS)	POSSIBLE AREAS OF MISADJUSTMENT(S)	RECOMMENDED COURSE OF ACTION
OUTPUT PROBLEMS		
<p>The machine has welding output but no control of output. The auxiliary power is normal.</p>	<ol style="list-style-type: none"> 1. If a remote control unit is connected to the machine, check the remote control and related cable. 2. Check the welding and work cables for loose or faulty connections. 	<ol style="list-style-type: none"> 1. Check the OUTPUT control potentiometer and related leads. See the Wiring Diagram. 2. Check the shunt and associated feedback leads. See the Wiring Diagram. 3. Check the voltage feedback leads for loose or faulty connections. See the Wiring Diagram. 4. Perform the Chopper Module Test. 5. The Weld Control PC board may be faulty. 6. Pull coil board may be faulty. Except tier II Cummins code 11181.
<p>The machine has low welding output and low auxiliary output</p>	<ol style="list-style-type: none"> 1. Check the brushes for wear and proper contact to the slip rings. 2. The engine RPM may be low. 	<ol style="list-style-type: none"> 1. If the engine high idle speed is low, perform the Throttle Adjustment Test. 2. Perform the Rotor Resistance Test. 3. Perform the Flashing and Rotor Voltage Test. If the rotor voltage is low, the field capacitor or field bridge may be faulty. Test and replace if necessary. See the Wiring Diagram. 4. If the engine high idle RPM is OK, then the engine may have lost horsepower and be in need of major repair. 5. Tier II Cummins - See EGC test and adjustment.

⚠ CAUTION

If for any reason you do not understand the test procedures or are unable to perform the tests/repairs safely, contact the Lincoln Electric Service Department for technical troubleshooting assistance before you proceed. Call 1-888-935-3877.

VANTAGE® 500



Observe Safety Guidelines detailed in the beginning of this manual.

PROBLEMS (SYMPTOMS)	POSSIBLE AREAS OF MISADJUSTMENT(S)	RECOMMENDED COURSE OF ACTION
FUNCTION PROBLEMS		
<p>The machine control is still active when the remote control unit is attached.</p>	<ol style="list-style-type: none"> 1. This is normal in TIG mode. 2. The remote control unit may be defective. 3. Check the Amphenol connections and associated wiring. 	<ol style="list-style-type: none"> 1. Check Plug J11 on the Weld Control PC board for loose or faulty connections. 2. The Weld Control PC board may be faulty.
<p>The machine seems locked into the CC mode of operation (Stick mode).</p>	<ol style="list-style-type: none"> 1. Check the position of the MODE SELECTOR switch. It must be in the correct position for the process being used. 	<ol style="list-style-type: none"> 1. Check the MODE SELECTOR switch and associated leads. See the Wiring Diagram. 2. The Weld Control PC board may be faulty.

⚠ CAUTION

If for any reason you do not understand the test procedures or are unable to perform the tests/repairs safely, contact the Lincoln Electric Service Department for technical troubleshooting assistance before you proceed. Call 1-888-935-3877.

VANTAGE® 500



Observe Safety Guidelines detailed in the beginning of this manual.

PROBLEMS (SYMPTOMS)	POSSIBLE AREAS OF MISADJUSTMENT(S)	RECOMMENDED COURSE OF ACTION
FUNCTION PROBLEMS		
<p>The wire feeder does not work when connected to the welder amphenol.</p>	<ol style="list-style-type: none"> 1. Check the appropriate circuit breaker (CB1 or CB6). Reset if tripped. 2. The wire feeder control cable may be faulty. 3. The wire feeder may be faulty. 	<ol style="list-style-type: none"> 1. Check for the presence of appropriate source voltage at the 14-pin amphenol. 2. If the appropriate voltage (42 VAC or 115 VAC) is NOT present at the 14-pin amphenol, check for loose or faulty connections. See the Wiring Diagram. 3. Perform the Stator Voltage Test.
<p>The battery does not stay charged.</p>	<ol style="list-style-type: none"> 1. Check for loose or faulty connections at the battery and engine charging system. 2. The battery may be faulty. Check or replace. 3. Loosen fan belt 	<ol style="list-style-type: none"> 1. The battery charging circuit may be faulty. Perform the Charging Circuit Test.

⚠ CAUTION

If for any reason you do not understand the test procedures or are unable to perform the tests/repairs safely, contact the Lincoln Electric Service Department for technical troubleshooting assistance before you proceed. Call 1-888-935-3877.

VANTAGE® 500



Observe Safety Guidelines detailed in the beginning of this manual.

PROBLEMS (SYMPTOMS)	POSSIBLE AREAS OF MISADJUSTMENT(S)	RECOMMENDED COURSE OF ACTION
ENGINE PROBLEMS		
<p>The engine will not crank when the start button is push</p>	<ol style="list-style-type: none"> 1. Check for loose or faulty battery cable connections. 2. The battery may be low or faulty. 3. The START button may be faulty. 	<ol style="list-style-type: none"> 1. The starter motor or starter solenoid may be faulty. 2. The engine may be hard to crank due to a mechanical failure in the engine.
<p>The engine cranks but will not start.</p>	<ol style="list-style-type: none"> 1. Check for adequate fuel supply (Check fuel filters). 2. Make sure the fuel shut off valve is in the open position. 3. The engine oil temperature may be too high. Check cooling system. 4. The battery voltage may be too low. 5. ON/OFF switch has been on for more than 30 seconds before starting (cycle switch OFF then ON.) 	<ol style="list-style-type: none"> 1. The shutdown solenoid may be faulty. Perform the Shutdown Solenoid Test. 2. The Peripheral PC board may be faulty. With the RUN/STOP switch in the "RUN" position, the Peripheral PC board should normally supply 10VDC to the shutdown solenoid via leads #232 and #262. See the Wiring Diagram. 3. The Pull Coil PC board may be faulty. Pull Coil Board supplies 12VDC for 3/4 second after Run Stop switch is activated. (Except tier II Cummins code 11181) 4. The engine may be in need of mechanical repair. 5. Tier II Cummins - check code 11181 governor control linkage for proper adjustment See EGC test and adjustment 6. Tier II Cummins electronic governor control board may be faulty.

⚠ CAUTION

If for any reason you do not understand the test procedures or are unable to perform the tests/repairs safely, contact the Lincoln Electric Service Department for technical troubleshooting assistance before you proceed. Call 1-888-935-3877.

Return to Section TOC

Return to Master TOC

Observe Safety Guidelines detailed in the beginning of this manual.

PROBLEMS (SYMPTOMS)	POSSIBLE AREAS OF MISADJUSTMENT(S)	RECOMMENDED COURSE OF ACTION
ENGINE PROBLEMS		
<p>The engine shuts down shortly after starting.</p>	<ol style="list-style-type: none"> 1. Check for adequate fuel supply. 2. If any indicator light is lit when the engine shuts down, that particular system has faulted. Check system. 3. Check the battery cables for loose or faulty connections. 	<ol style="list-style-type: none"> 1. Check the RUN/STOP switch and associated leads for loose or faulty connections. 2. Perform the Shutdown Solenoid Test. (except tier II Cummins) 3. The Peripheral PC board may be faulty. With the RUN/STOP switch in the "RUN" position, the Peripheral PC board should normally supply 10VDC to the shutdown solenoid via leads #252 and #262. See the Wiring Diagram. (except tier II Cummins code 11181. 4. Tier II Cummins electronic governor control board may be faulty misadjusted governor linkage see EGC test + adjustments.
<p>The engine will not idle down to low speed. The machine has normal weld output and auxiliary power.</p>	<ol style="list-style-type: none"> 1. Make sure the IDLER switch is in the "AUTO" position. 2. Make sure there is NOT an external load on the weld terminals nor the auxiliary power receptacles. 3. Check for mechanical restrictions in the solenoid linkage. 	<ol style="list-style-type: none"> 1. Perform the Idler Solenoid Test. 2. Check leads #227, #232L, #232M and #226A for loose or faulty connections. See the Wiring Diagram. 3. The Pull Coil PC board may be faulty. (Except tier II Cummins). 4. Tier II Cummins electronic control board may be faulty - misadjusted governor linkage see EGC test & adjustment.

⚠ CAUTION

If for any reason you do not understand the test procedures or are unable to perform the tests/repairs safely, contact the Lincoln Electric Service Department for technical troubleshooting assistance before you proceed. Call 1-888-935-3877.

Return to Section TOC

Return to Section TOC

Return to Section TOC

Return to Section TOC

Return to Master TOC

Return to Master TOC

Return to Master TOC

Return to Master TOC

Observe Safety Guidelines detailed in the beginning of this manual.

PROBLEMS (SYMPTOMS)	POSSIBLE AREAS OF MISADJUSTMENT(S)	RECOMMENDED COURSE OF ACTION
ENGINE PROBLEMS		
<p>The engine will not go to high idle when using the auxiliary power. Auxiliary power is normal when the IDLER switch is in the "HIGH" position. Automatic idle function works properly when the welding terminals are loaded</p>	<ol style="list-style-type: none"> 1. Make sure the auxiliary power leads are tight. 2. The automatic idler may not function if the auxiliary power is loaded to less than 150 watts. 	<ol style="list-style-type: none"> 1. Check the current sensing toroid for loose or faulty connections. See the Wiring Diagram. 2. Make sure leads #3 and #6A pass through the toroid twice in opposite directions. 3. The current sensing toroid may be faulty. 4. Pull coil board may be faulty 5. The Weld Control PC board may be faulty. 6. Tier II Cummins governor control board may be faulty- mis-adjusted governor linkage see EGC test & adjustment
<p>The engine will not go to high idle when attempting to weld or when the auxiliary power is loaded. Welding output and auxiliary power outputs are normal when IDLER switch is in the " HIGH" position</p>	<ol style="list-style-type: none"> 1. Make sure the welding cables and auxiliary power lead connections are tight. 	<ol style="list-style-type: none"> 1. The Weld Control PC board may be faulty. 2. Pull coil board may be faulty 3. Tier II Cummins Governor Control may be faulty.

⚠ CAUTION

If for any reason you do not understand the test procedures or are unable to perform the tests/repairs safely, contact the Lincoln Electric Service Department for technical troubleshooting assistance before you proceed. Call 1-888-935-3877.

Return to Section TOC

Return to Section TOC

Return to Section TOC

Return to Section TOC

Return to Master TOC

Return to Master TOC

Return to Master TOC

Return to Master TOC

Observe Safety Guidelines detailed in the beginning of this manual.

PROBLEMS (SYMPTOMS)	POSSIBLE AREAS OF MISADJUSTMENT(S)	RECOMMENDED COURSE OF ACTION
ENGINE PROBLEMS		
<p>The machine goes to low idle but does not stay at low idle.</p>	<p>1. Make sure there is NOT an external load (auxiliary or weld) connected to the Vantage 500.</p>	<ol style="list-style-type: none"> 1. The idler solenoid linkage may be misadjusted or damaged. 2. The idler solenoid lead connections may be loose or damaged. See the Wiring Diagram. 3. Perform the Idler Solenoid Test. 4. Pull coil board may be faulty except tier II Cummins code 11181. 5. The Weld Control PC board may be faulty. 6. Tier II Cummins governor control board may be faulty see EGC test & adjustment.
WELDING PROBLEMS		
<p>The welding arc is "cold." The engine runs normally. The auxiliary power is normal.</p>	<ol style="list-style-type: none"> 1. Check for loose or faulty connections at the weld output terminals and welding cable connections. 2. The welding cables may be too long or coiled, causing an excessive voltage drop. 3. Make sure the electrode (wire, gas, voltage, current etc.) is correct for the process being used. 	<ol style="list-style-type: none"> 1. Check for the correct OCV at the welding output terminals. If the correct voltage is present at the output terminals, check for loose connection on the heavy current carrying leads inside the Vantage 500. See the Wiring Diagram. 2. If the OCV is low at the welder output terminals, perform the Engine Throttle Adjustment Test. 3. Perform the Output Rectifier Bridge Test. 4. Perform the Stator Voltage Test. 5. Perform the Chopper Module Test. 6. The Weld Control PC board may be faulty.

⚠ CAUTION

If for any reason you do not understand the test procedures or are unable to perform the tests/repairs safely, contact the Lincoln Electric Service Department for technical troubleshooting assistance before you proceed. Call 1-888-935-3877.

VANTAGE® 500



CASE COVER REMOVAL AND REPLACEMENT PROCEDURE**⚠ WARNING**

Service and repair should be performed by only Lincoln Electric factory trained personnel. Unauthorized repairs performed on this equipment may result in danger to the technician or machine operator and will invalidate your factory warranty. For your safety and to avoid electrical shock, please observe all safety notes and precautions detailed throughout this manual.

If for any reason you do not understand the test procedures or are unable to perform the test/repairs safely, contact the Lincoln Electric Service Department for electrical troubleshooting assistance before you proceed. Call 1-888-935-3877.

TEST DESCRIPTION

This procedure will aid the technician in the removal and replacement of the case sheet metal covers.

MATERIALS NEEDED

- 3/8" wrench
- 7/16" wrench
- 1/2" wrench
- 3/4" wrench

NOTE: Because the Vantage® 500 uses several different models of both Cummins and Deutz engines, the removal and replacement procedures may vary from the descriptions in this manual. Refer to the engine manufacturer's manuals for more specific information.

CASE COVER REMOVAL AND REPLACEMENT PROCEDURE (continued)

FIGURE F.1 – DOOR REMOVAL

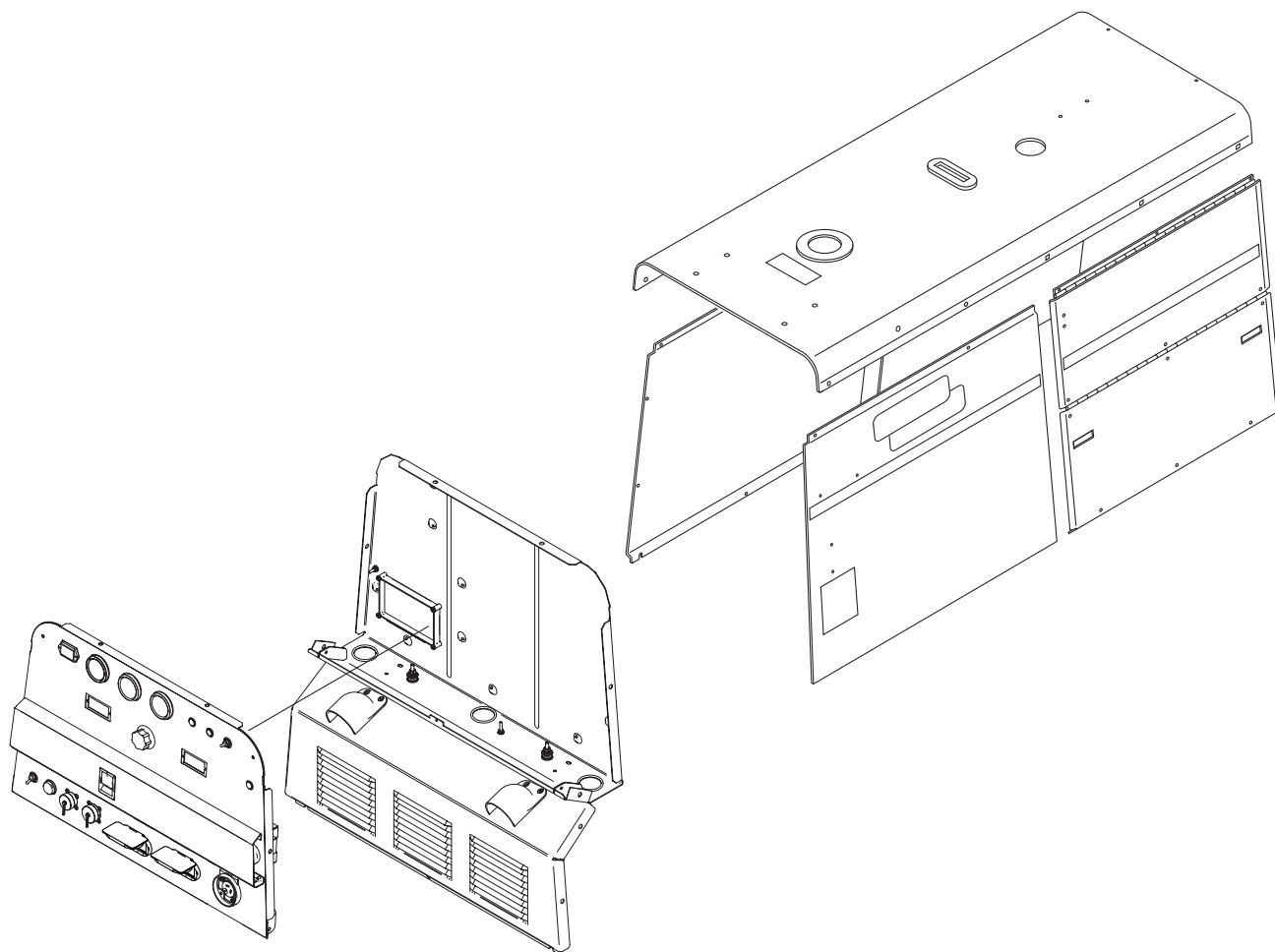

PROCEDURE

1. Turn the engine off.
2. Using the 3/8" wrench, remove the battery cover. Slide the battery out and disconnect the negative battery cable.
3. Unlatch and open the engine service access door.
4. Support the door assembly. Using the 3/8" wrench, remove the #10-24 round head screw, lock washer, flat washer, and nut from the top corner of the door hinge assembly where it attaches to the roof. Remove the support rod.
5. Using the 3/8" wrench, remove the screws from the top front of the roof assembly and the screws from the sides of the control box. Carefully lower the front control panel.
6. With the 9/16" wrench, remove the exhaust pipe rain cap.
7. Remove the fuel tank cap, gasket, and the lift bail cover seal.
8. With the help of an assistant, carefully remove the roof. The door assembly remains attached to the roof. Replace the fuel cap.
9. With 3/8" wrench, remove the left rear panel and the right and left front panels.

CHOPPER MODULE CAPACITOR DISCHARGE PROCEDURE**⚠ WARNING**

Service and repair should be performed by only Lincoln Electric factory trained personnel. Unauthorized repairs performed on this equipment may result in danger to the technician or machine operator and will invalidate your factory warranty. For your safety and to avoid electrical shock, please observe all safety notes and precautions detailed throughout this manual.

If for any reason you do not understand the test procedures or are unable to perform the test/repairs safely, contact the Lincoln Electric Service Department for electrical troubleshooting assistance before you proceed. Call 1-888-935-3877.

TEST DESCRIPTION

This procedure will insure that the large capacitors in the chopper modules have been discharged. This procedure should be performed whenever work is to be attempted on or near the chopper modules.

MATERIALS NEEDED

- Miscellaneous Hand Tools
- Volt/Ohmmeter
- Resistor (25-1000 ohms and 25 watts minimum)
- Jumper leads
- Wiring diagram

CHOPPER MODULE CAPACITOR DISCHARGE PROCEDURE (CONTINUED)

FIGURE F.2 – CHOPPER MODULE CAPACITOR TERMINAL DISCHARGE

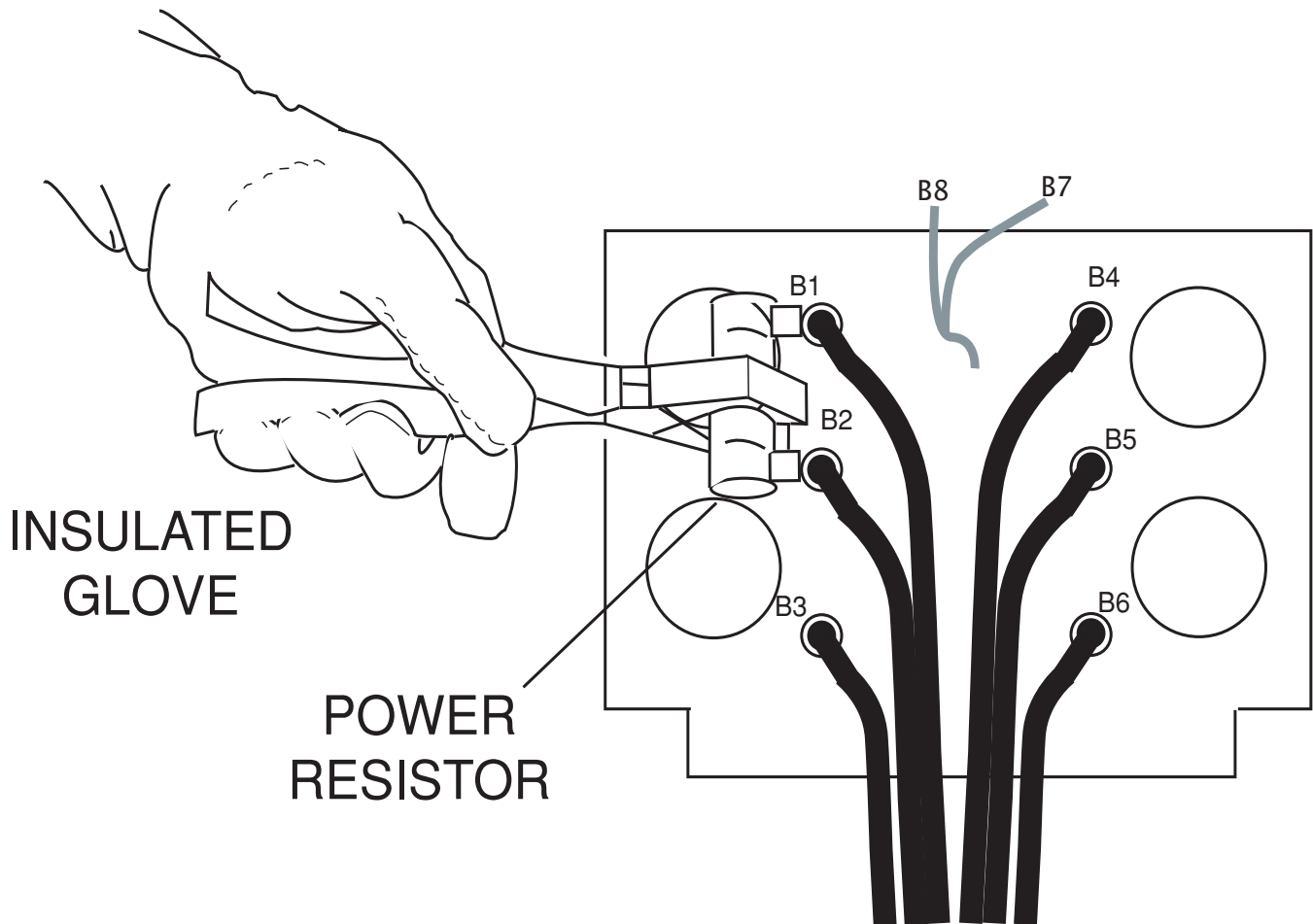

PROCEDURE

1. Turn engine off.
2. Perform the **Case Cover Removal Procedure**.

Note: It is necessary to remove the fuel cap in order to take the case cover off the machine. Be sure the fuel cap is ON when discharging the chopper module capacitors.

3. Locate the chopper module on the inner machine baffle. See Figure F.2 and the Wiring Diagram.

4. Discharge Capacitors.

If the Lincoln recommended resistor, or an equivalent resistor is used, the capacitors can be discharged by holding the resistor with insulated pliers and using the resistor terminals to bridge chopper module terminals B1 to B2, and B4 to B5. **DO NOT TOUCH THE TERMINALS OR METAL PARTS OF THE PLIERS WITH YOUR BARE HANDS.** Hold the resistor in place for about 10 seconds.

If another type of resistor is used, jumper leads may need to be attached to the resistor. The leads can then be used to connect terminals B1 to B2, and B4 to B5.

5. Using the volt/ohmmeter, check the voltage across B1 and B2 then B4 and B5. It should be zero volts in both cases. See Figure F.2.

CHOPPER MODULE RESISTANCE TEST PROCEDURE**⚠ WARNING**

Service and repair should be performed by only Lincoln Electric factory trained personnel. Unauthorized repairs performed on this equipment may result in danger to the technician or machine operator and will invalidate your factory warranty. For your safety and to avoid electrical shock, please observe all safety notes and precautions detailed throughout this manual.

If for any reason you do not understand the test procedures or are unable to perform the test/repairs safely, contact the Lincoln Electric Service Department for electrical troubleshooting assistance before you proceed. Call 1-888-935-3877.

TEST DESCRIPTION

This test will help determine if the chopper module is shorted. This test can only detect some problems in the "Power" section of the module. Problems in some other PC board components may not be detected.

MATERIALS NEEDED

- Miscellaneous hand tools
- Digital Ohmmeter
- Wiring Diagram

CHOPPER MODULE RESISTANCE TEST (CONTINUED)

FIGURE F.3 – LEADS & TERMINALS

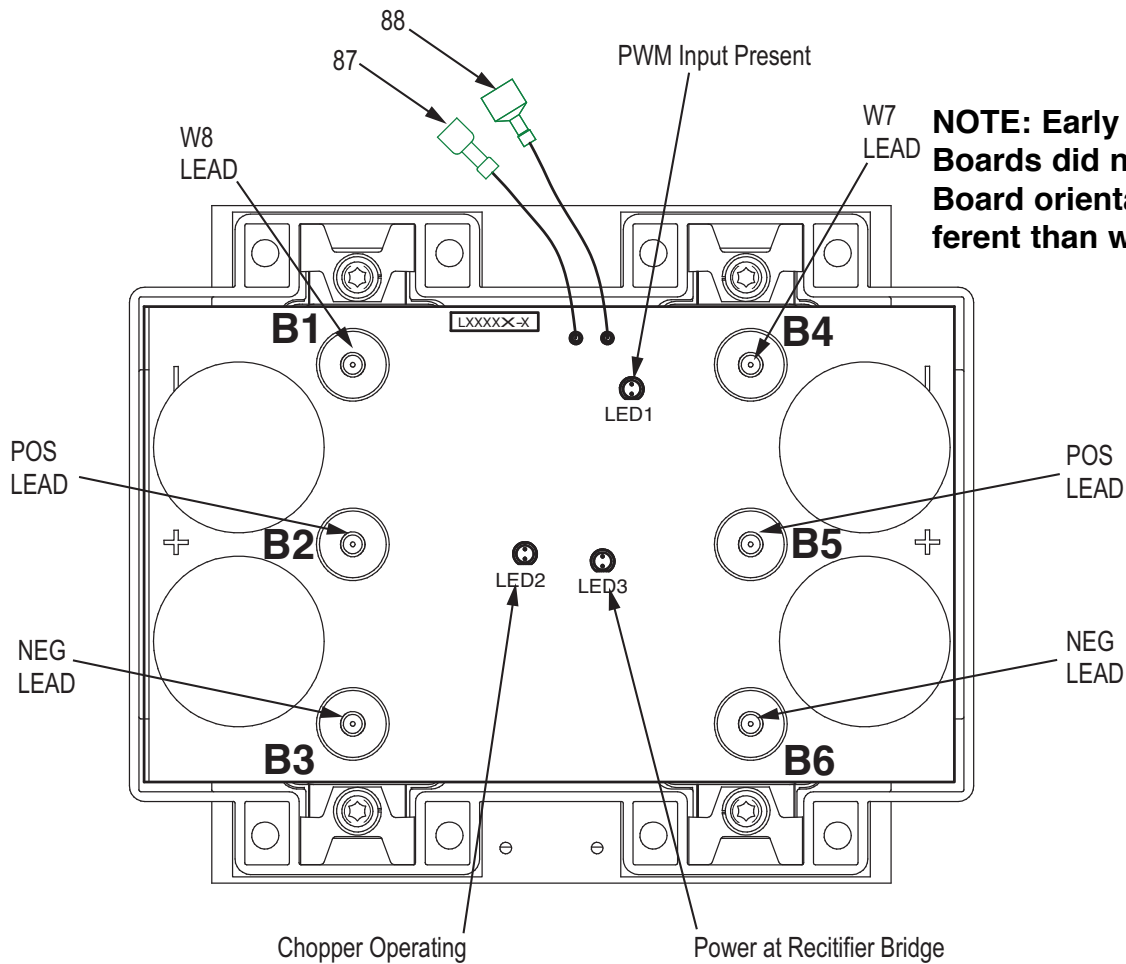

NOTE: Early design P C Boards did not have LED's. Board orientation may be different than what is shown.

PROCEDURE

1. Turn the engine off.
2. Perform the **Case Cover Removal procedure**.
3. Perform the **Capacitor Discharge procedure**.
4. Use a 7/16" wrench, label and disconnect the six heavy black flex leads W8, positive, negative W7, positive, negative from the Power Module PC Board.
5. Using the 7/16' wrench, remove the negative jumper strap attaching the power capacitors to the Power Module PC Board.
6. Check resistance with analog ohmmeter per the "Chopper Test" **Table F.1**.
Note: Make sure the bolts do not fall back against the heat sink.
7. Reconnect all leads.
Note: The chopper module screw connections should be tightened to 50-60 inch-pounds.
8. Perform the **Case Cover Replacement Procedure**.

CHOPPER MODULE RESISTANCE TEST (CONTINUED)

TABLE F.1 – CHOPPER TEST TABLE

CHOPPER TERMINAL CONNECTIONS	CHOPPER TEST		
	OHMMETER		OHMMETER READING
	(+) Lead	(-) Lead	
	B5	B6	6k to 9k
	B6	B5	6k to 9k
	B4	B5	200k or higher
	B5	B4	400k or higher
	B4	B6	200k or higher
	B6	B4	400k or higher
	B2	B3	6k to 9k
	B3	B2	6k to 9k
	B4	B2	200k or higher
	B2	B4	400k or higher
	B4	B3	200k or higher
	B3	B4	400k or higher

Return to Section TOC

Return to Section TOC

Return to Section TOC

Return to Section TOC

Return to Master TOC

Return to Master TOC

Return to Master TOC

Return to Master TOC

Return to Section TOC

Return to Section TOC

Return to Section TOC

Return to Section TOC

Return to Master TOC

Return to Master TOC

Return to Master TOC

Return to Master TOC

VANTAGE® 500



IDLER SOLENOID TEST PROCEDURE (CUMMINS ENGINE ONLY)

WARNING

Service and repair should be performed by only Lincoln Electric factory trained personnel. Unauthorized repairs performed on this equipment may result in danger to the technician or machine operator and will invalidate your factory warranty. For your safety and to avoid electrical shock, please observe all safety notes and precautions detailed throughout this manual.

If for any reason you do not understand the test procedures or are unable to perform the test/repairs safely, contact the Lincoln Electric Service Department for electrical troubleshooting assistance before you proceed. Call 1-888-935-3877.

TEST DESCRIPTION

This test will determine if the idler solenoid is capable of functioning when it is energized with 12VDC.

MATERIALS NEEDED

- External 12VDC supply (30 amps required)
- Wiring Diagram
- Volt/Ohmmeter

NOTE: Because the Vantage® 500 uses several different models of both Cummins and Deutz engines, the removal and replacement procedures may vary from the descriptions in this manual. Refer to the engine manufacturer's manuals for more specific information.

IDLER SOLENOID TEST PROCEDURE (CONTINUED)

FIGURE F.4 – IDLER SOLENOID LEAD TERMINALS

Cummins Engine

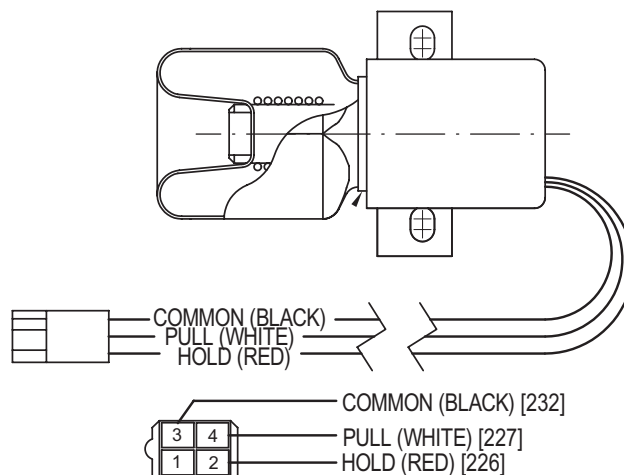
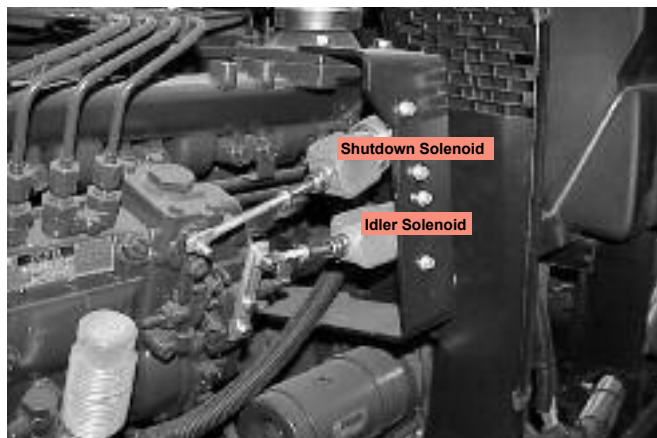

TEST PROCEDURE

1. Turn the engine off.
2. Unlatch, lift, and secure the right side engine service access door.
3. Locate and separate J55/P55 connector that attaches the idler solenoid leads to the wiring harness leads (#226, #227 and #232L). See Figure F.4 and the Wiring Diagram. Remove and replace necessary wire wraps.
4. Check the pull-in coil resistance (White to Black #227 to #232L). The normal resistance is approximately 0.2 ohms.

Check the hold-in coil resistance (Red to Black #226A to #232S). Normal coil resistance is approximately 11 ohms.

If either coil resistance is not correct, the solenoid may be faulty. Replace.

5. Using the external 12VDC supply, apply 12VDC to the pull coil terminals (#227 to #232L +). The solenoid should activate.

⚠ CAUTION

When the solenoid activates, remove the voltage supply immediately. Leaving the external supply connected to terminals #232M and #265 for longer than three seconds will damage the coil.

- The solenoid should deactivate when the 12VDC is removed.
6. If the solenoid does not operate properly, check for a mechanical restriction in the linkage.
 7. Using the external 12VDC supply, apply 12VDC to the hold idler solenoid terminals for the hold-in coil (#226 to #232 +). Push in the solenoid plunger. With 12 VDC applied to the hold-in coil, the plunger should stay in until the 12 VDC is removed.
 8. If the linkage is intact and the solenoid does not operate correctly when the 12VDC is applied, the solenoid may be faulty. Replace.
 9. Replace harness connectors. See Figure F.4 and the Wiring Diagram. Replace any previously removed wire wraps.
 10. Close and secure the right side engine service access door.

TROUBLESHOOTING AND REPAIR

SHUTDOWN SOLENOID TEST PROCEDURE

WARNING

Service and repair should be performed by only Lincoln Electric factory trained personnel. Unauthorized repairs performed on this equipment may result in danger to the technician or machine operator and will invalidate your factory warranty. For your safety and to avoid electrical shock, please observe all safety notes and precautions detailed throughout this manual.

If for any reason you do not understand the test procedures or are unable to perform the test/repairs safely, contact the Lincoln Electric Service Department for electrical troubleshooting assistance before you proceed. Call 1-888-935-3877.

TEST DESCRIPTION

This test will determine if the shutdown solenoid is capable of functioning when it is energized with 12VDC.

MATERIALS NEEDED

- External 12VDC supply (30 amps required)
- Wiring Diagram
- Volt/Ohmmeter

NOTE: Because the Vantage® 500 uses several different models of both Cummins and Deutz engines, the removal and replacement procedures may vary from the descriptions in this manual. Refer to the engine manufacturer's manuals for more specific information.

FIGURE F.5 – SHUTDOWN SOLENOID

Cummins Engine

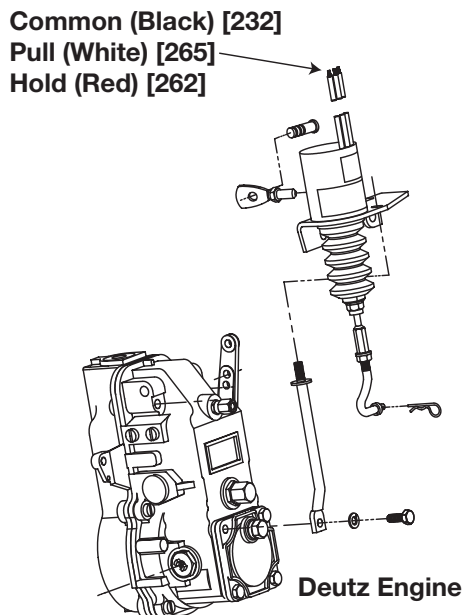
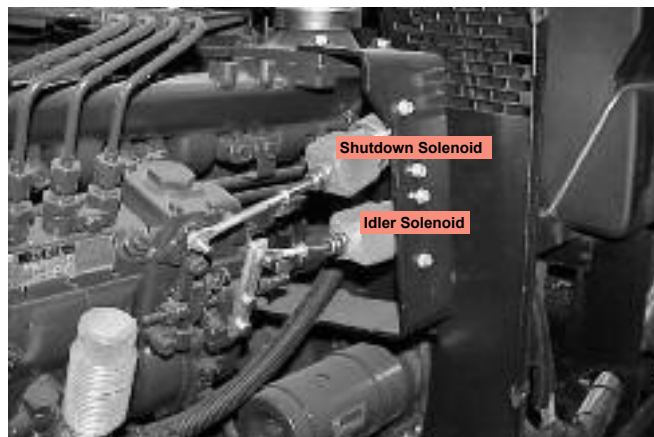

TEST PROCEDURE

1. Turn the engine off.
2. Unlatch, lift, and secure the right side engine service access door.
3. Locate and separate J54 / P54 connector that attaches the shutdown solenoid leads to the wiring harness leads (#262, #232 and #265). See Figure F.5 and the Wiring Diagram. Remove any necessary wire wraps.
4. Check the pull-in coil resistance (Black to White #232 to #265). The normal resistance is approximately 0.2 ohms.

Check the hold-in coil resistance (Black to Red #232 to #262). Normal coil resistance is approximately 11 ohms.

If either coil resistance is not correct, the solenoid may be faulty. Replace.

5. Using the external 12VDC supply, apply 12VDC to the pull coil shutdown solenoid terminals (#232M+ to #265-). The solenoid should activate.

⚠ CAUTION

When the solenoid activates, remove the voltage supply immediately. Leaving the external supply connected to terminals #232M and #265 for longer than three seconds will damage the coil.

- The solenoid should deactivate when the 12VDC is removed.
6. If the solenoid does not operate properly, check for a mechanical restriction in the linkage.
 7. Using the external 12VDC supply, apply 12VDC to the hold coil solenoid terminals for the hold-in coil (#262- to #232+). Push in the solenoid plunger. With 12 VDC applied to the hold-in coil, the plunger should stay in until the 12 VDC is removed.
 8. If the linkage is intact and the solenoid does not operate correctly when the 12VDC is applied, the solenoid may be faulty. Replace.
 9. Replace harness connector. See Figure F.5 and the Wiring Diagram. Replace any previously removed wire wraps.
 10. Close and secure the right side engine service access door.

ENGINE THROTTLE ADJUSTMENT TEST PROCEDURE (CUMMINS ENGINE ONLY)

WARNING

Service and repair should be performed by only Lincoln Electric factory trained personnel. Unauthorized repairs performed on this equipment may result in danger to the technician or machine operator and will invalidate your factory warranty. For your safety and to avoid electrical shock, please observe all safety notes and precautions detailed throughout this manual.

If for any reason you do not understand the test procedures or are unable to perform the test/repairs safely, contact the Lincoln Electric Service Department for electrical troubleshooting assistance before you proceed. Call 1-888-935-3877.

TEST DESCRIPTION

If the machine output is low or high, this test will determine whether the engine is operating at the correct speed (RPM) during both HIGH and LOW idle conditions. Directions for adjusting the throttle to the correct RPM are given.

MATERIALS NEEDED

- Slot head screw driver
- 10mm Wrench
- White or red marking pencil
- Strobe-tach, frequency counter, or oscilloscope

NOTE: Because the Vantage® 500 uses several different models of both Cummins and Deutz engines, the removal and replacement procedures may vary from the descriptions in this manual. Refer to the engine manufacturer's manuals for more specific information.

ENGINE THROTTLE ADJUSTMENT TEST PROCEDURE (*CONTINUED*)

FIGURE F.6 – STROBE MARK LOCATION

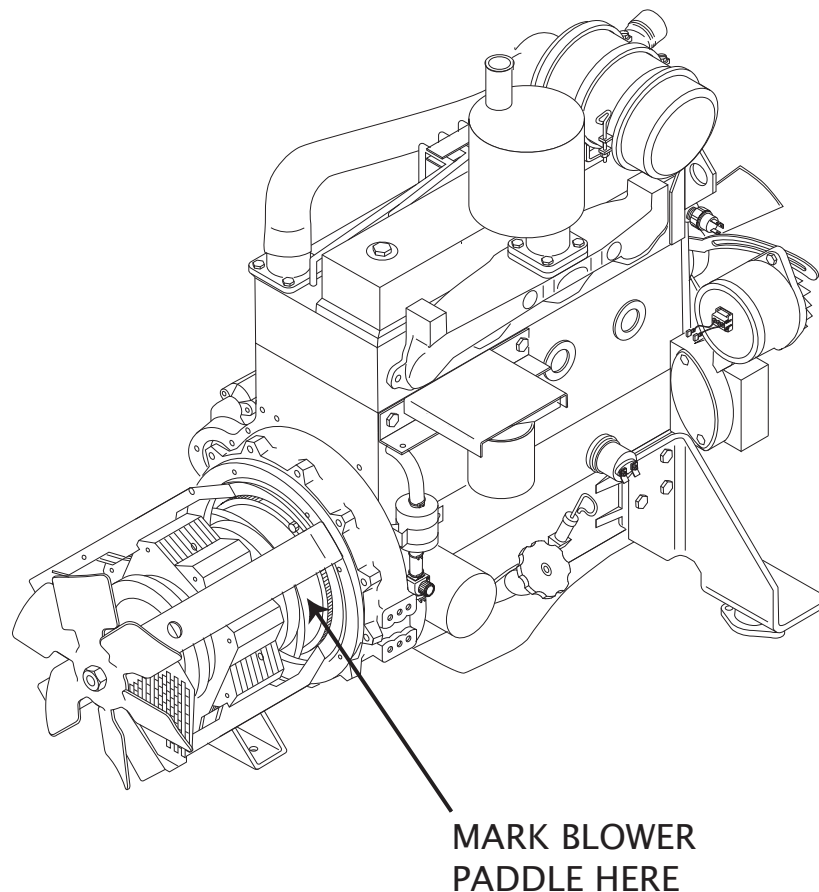
**PROCEDURE****Strobe-tach Method**

1. Conduct this procedure with the engine OFF.
2. Unlatch, lift and secure the right side engine service access door. Perform the **Case Cover Removal and Replacement Procedure**. (For Strobe-Tach method only.)
3. With a white or red marking pencil, place a mark on one of the blower paddles. See Figure F.6 for location.
4. Connect the strobe-tach according to the manufacturer's instructions.
5. Start the engine and direct the strobe-tach light on the blower. Synchronize it to the rotating mark.
6. If either of the readings is incorrect, adjust the throttle as follows:

Adjust HIGH IDLE: Use the 10mm wrench to loosen the locking nut. See Figure F.7 for location of the adjusting screw and locking nut. Turn the threaded screw counter-clockwise to increase the HIGH IDLE speed. Adjust the speed until the tach reads between 1890 and 1910 RPM. Retighten the locking nut.

Adjust LOW IDLE: First make sure there is no load on the machine. Set the IDLE switch to AUTO and wait for the engine to change to low idle speed. Use the 10mm wrench to loosen the solenoid lever arm locking nut. See Figure F.7. Adjust the collar, to change the amount of throw in the lever arm, until the tach reads between 1450 and 1500 RPM. Retighten the locking nut.

With the machine at HIGH IDLE the tach should read between 1890 and 1910 RPM.

With the machine at LOW IDLE the tach should read between 1450 and 1500 RPM. (Cummins 1425).

ENGINE THROTTLE ADJUSTMENT TEST PROCEDURE (CONTINUED)

FIGURE F.7 – HIGH AND LOW IDLE ADJUSTMENTS - CUMMINS ENGINE ONLY

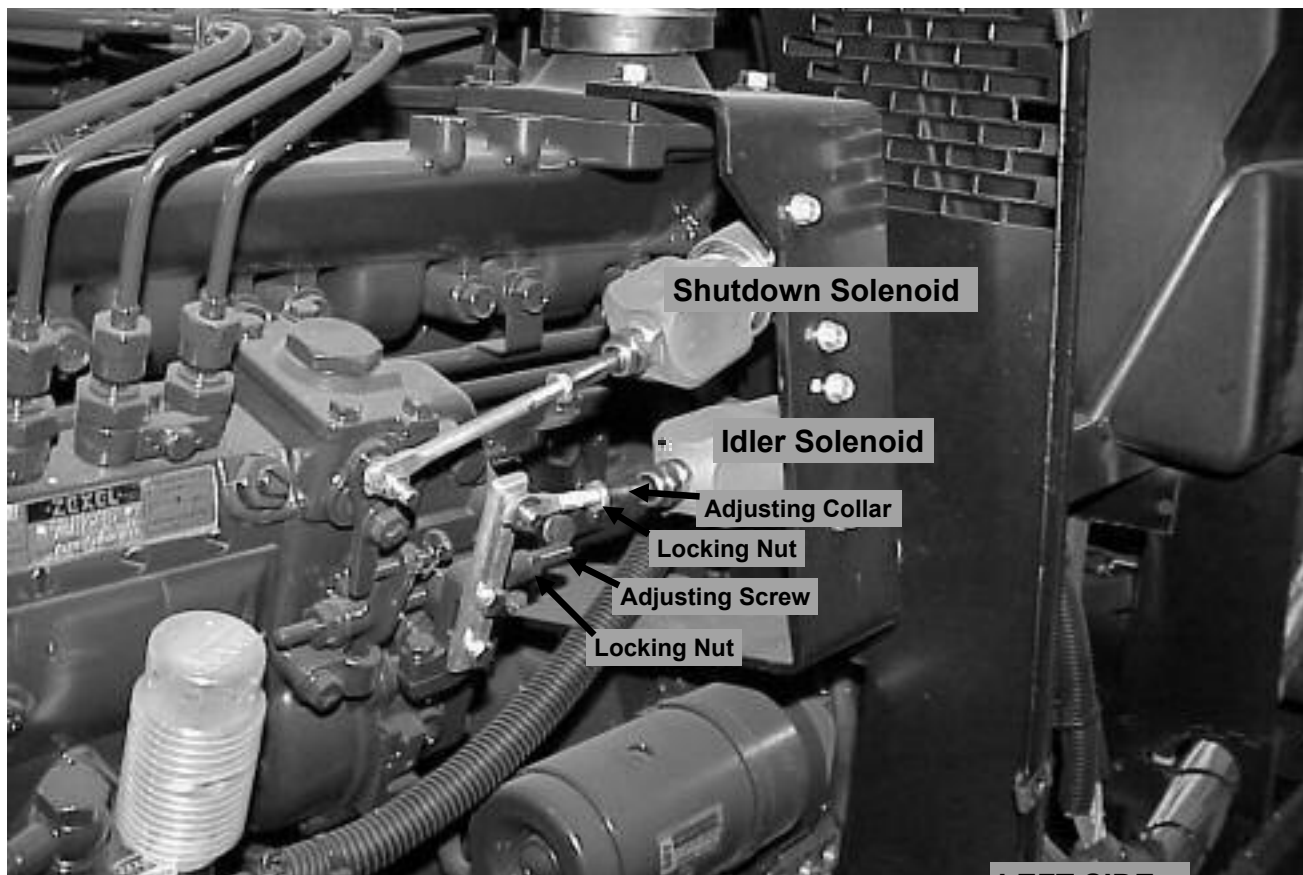

PROCEDURE

Frequency Counter Method

1. Plug the frequency counter into one of the 115 VAC auxiliary receptacles.
2. Start the engine and check the frequency counter. At HIGH IDLE (1900 RPM), the counter should read 63 Hz. At LOW IDLE (1475 RPM), the counter should read 49 Hz. Note that these are median measurements; hertz readings may vary slightly above or below.
3. If either of the readings is incorrect, adjust the throttle as follows:

Adjust HIGH IDLE: Use the 10mm wrench to loosen the locking nut. See Figure F.7 for location of the adjusting screw and locking nut. Turn the threaded screw counter-clockwise to increase the HIGH IDLE speed. Adjust the speed until the frequency reads 63 Hz. Retighten the locking nut.

Adjust LOW IDLE: First make sure there is no load on the machine. Set the IDLE switch to AUTO and wait for the engine to change to low idle speed. Use the 10mm wrench to loosen the solenoid lever arm locking nut. See Figure F.7. Adjust the collar, to change the amount of throw in the lever arm, until the frequency reads 49 Hz. Retighten the locking nut.

ENGINE THROTTLE ADJUSTMENT TEST PROCEDURE (CONTINUED)

PROCEDURE

Oscilloscope Method

1. Connect the oscilloscope to the 115 VAC receptacle, according to the manufacturer's instructions. At HIGH IDLE (1900 RPM), the waveform should exhibit a period of 15.8 milliseconds. At LOW IDLE (1475 RPM), the waveform should exhibit a period of 20.3 milliseconds. Refer to the **NORMAL OPEN CIRCUIT VOLTAGE WAVEFORM (115 VAC SUPPLY) HIGH IDLE - NO LOAD** below.
2. If either of these waveform periods is incorrect, adjust the throttle as follows:

Adjust HIGH IDLE: Use the 10mm wrench to loosen the locking nut. See **Figure F.7** for location of the adjusting screw and locking nut. Turn the threaded screw counter-clockwise to increase the HIGH IDLE speed. Adjust the speed until the period is 15.8 milliseconds. Retighten the locking nut.

Adjust LOW IDLE: First make sure there is no load on the machine. Set the IDLE switch to AUTO and wait for the engine to change to low idle speed. Use the 10mm wrench to loosen the solenoid lever arm locking nut. See **Figure F.7** Adjust the collar, to change the amount of throw in the lever arm, until the period is 20.3 milliseconds. Retighten the locking nut.

NORMAL OPEN CIRCUIT VOLTAGE WAVEFORM (115VAC SUPPLY) HIGH IDLE – NO LOAD

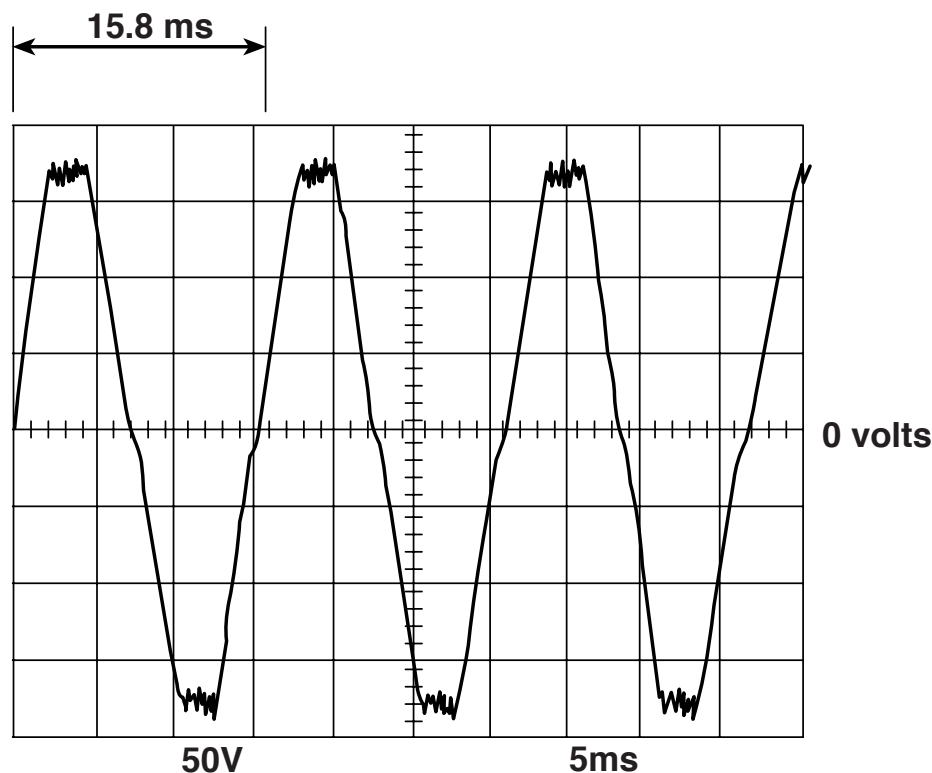

This is the typical auxiliary output voltage generated from a properly operating machine.

Note that each vertical division represents 50 volts and that each horizontal division represents 5 milliseconds in time.

Note: Scope probes are connected at machine 115VAC receptacle.

ROTOR RESISTANCE TEST**⚠ WARNING**

Service and repair should be performed by only Lincoln Electric factory trained personnel. Unauthorized repairs performed on this equipment may result in danger to the technician or machine operator and will invalidate your factory warranty. For your safety and to avoid electrical shock, please observe all safety notes and precautions detailed throughout this manual.

If for any reason you do not understand the test procedures or are unable to perform the test/repairs safely, contact the Lincoln Electric Service Department for electrical troubleshooting assistance before you proceed. Call 1-888-935-3877.

TEST DESCRIPTION

This test will determine if there is a shorted winding in the rotor or if the rotor is grounded.

MATERIALS NEEDED

Ohmmeter
3/8" Wrench or socket wrench

FIGURE F.8 – ROTOR BRUSH LEADS

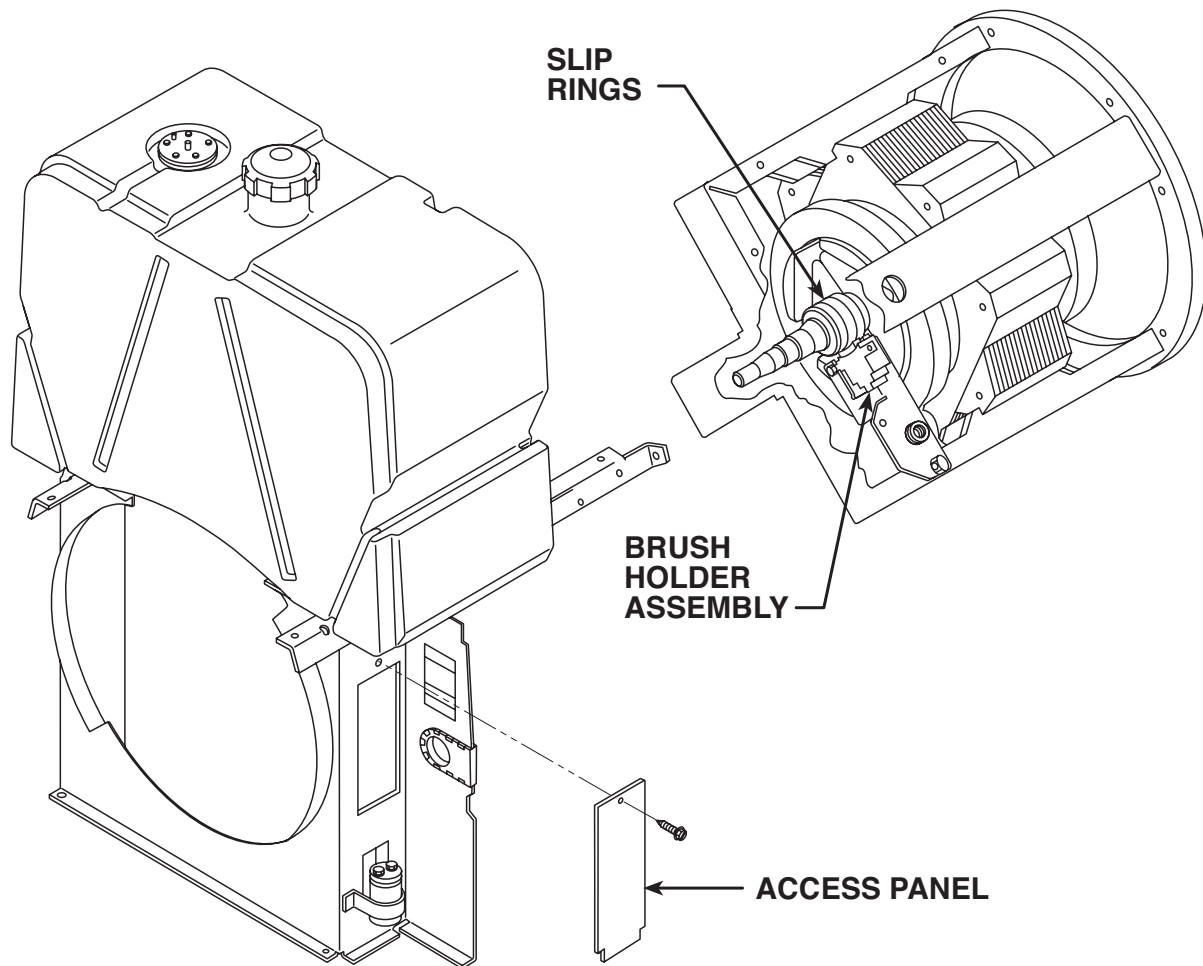

PROCEDURE

1. Conduct this test with the engine off.
2. Using the 3/8" wrench, remove the right front case side.
3. Using the 3/8" wrench, remove the brush holder access panel. See Figure F.10.
4. Using the 3/8" wrench, remove the brush holder assembly. See Figure F.10.
5. Using the ohmmeter, check the rotor winding resistance across the slip rings. Normal resistance is approximately 27.0 ohms.
6. Measure the resistance to ground. Place one meter probe on either of the slip rings. Place the other probe on any good unpainted ground. The resistance should be very high, at least 500,000 ohms.
7. If the test does not meet the resistance specifications, then the rotor may be faulty. Replace.
8. Position the brush holder assembly and attach it with two screws previously removed. Make certain the brushes are centered and seated properly on the slip rings. Adjust if necessary.
9. Replace the brush holder access panel.
10. Replace the right front case cover.

TROUBLESHOOTING AND REPAIR

FLASHING AND ROTOR VOLTAGE TEST

WARNING

Service and repair should be performed by only Lincoln Electric factory trained personnel. Unauthorized repairs performed on this equipment may result in danger to the technician or machine operator and will invalidate your factory warranty. For your safety and to avoid electrical shock, please observe all safety notes and precautions detailed throughout this manual.

If for any reason you do not understand the test procedures or are unable to perform the test/repairs safely, contact the Lincoln Electric Service Department for electrical troubleshooting assistance before you proceed. Call 1-888-935-3877.

TEST DESCRIPTION

This test will determine if the correct DC voltage is being applied to the rotor at the maximum engine speed (1900 RPM). This information will aid the technician in determining if the generator field is operating properly.

MATERIALS NEEDED

- Volt/Ohmmeter
- 3/8" Wrench
- Wiring Diagram

FLASHING AND ROTOR VOLTAGE TEST (CONTINUED)

FIGURE F.9 – ROTOR BRUSH LOCATION

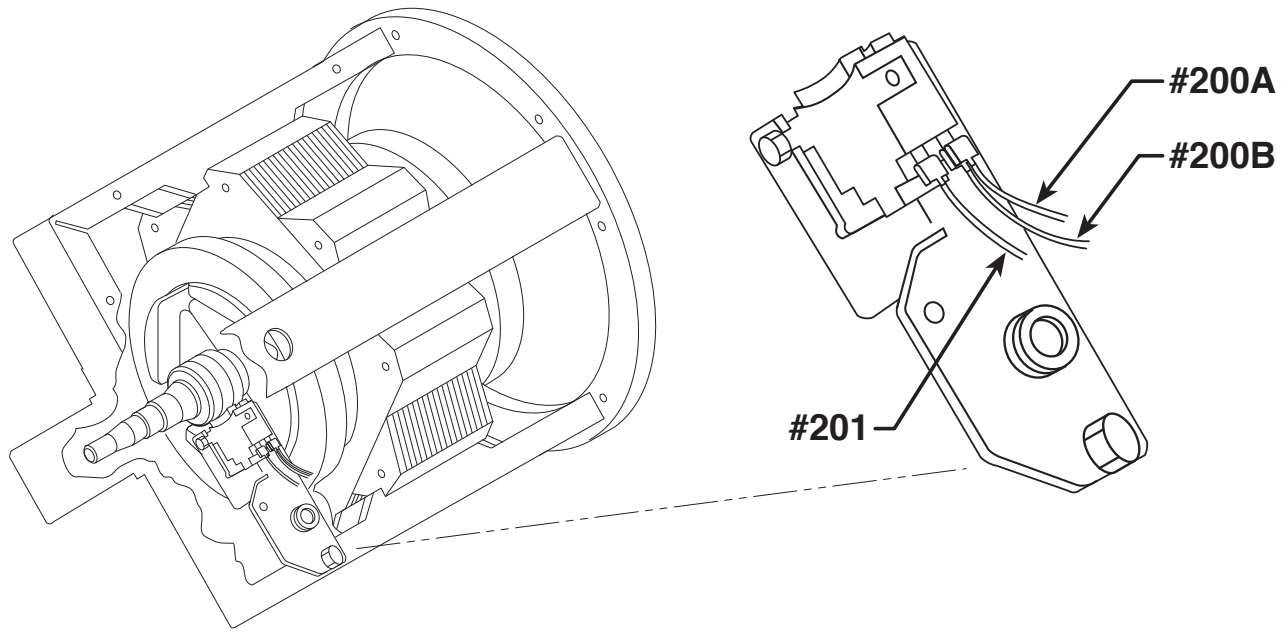

PROCEDURE

1. Using the 3/8" wrench, remove the sheet metal screws from the right front case side.
2. Carefully remove the right case side.
3. Set the volt/ohmmeter to the DC volts position.
4. Locate leads #200A and #201A at the rotor brushes.

NOTE: Cut any cable ties necessary to perform the test.

5. Connect the positive meter probe to lead #200B and the negative meter probe to lead #201.
6. Start the engine and run it at high idle speed (1900 RPM). Check the voltage reading on the meter. It should read approximately 120 VDC.

7. If the voltage reading is low or not present, the generator field is not functioning properly. Perform the **Rotor Resistance Test**. Also check the field diode rectifier bridge, filter capacitor, and associated leads and connections. See the Wiring Diagram.

NOTE: The normal flashing voltage is approximately 9VDC. This is battery voltage, which is processed through the Pull Coil PC Board. This voltage must be present during start-up to "flash" the rotor field.

8. If the rotor voltage readings are normal, the field circuit is functioning properly. Replace any cable ties cut during the test. Install the right case side.

STATOR VOLTAGE TEST**⚠ WARNING**

Service and repair should be performed by only Lincoln Electric factory trained personnel. Unauthorized repairs performed on this equipment may result in danger to the technician or machine operator and will invalidate your factory warranty. For your safety and to avoid electrical shock, please observe all safety notes and precautions detailed throughout this manual.

If for any reason you do not understand the test procedures or are unable to perform the test/repairs safely, contact the Lincoln Electric Service Department for electrical troubleshooting assistance before you proceed. Call 1-888-935-3877.

TEST DESCRIPTION

This test will determine if the correct AC voltages are being generated from the stator windings.

MATERIALS NEEDED

Volt/Ohmmeter
3/8" wrench
3/4" Wrench

FIGURE F.10 – FRONT CONTROL PANEL REMOVAL

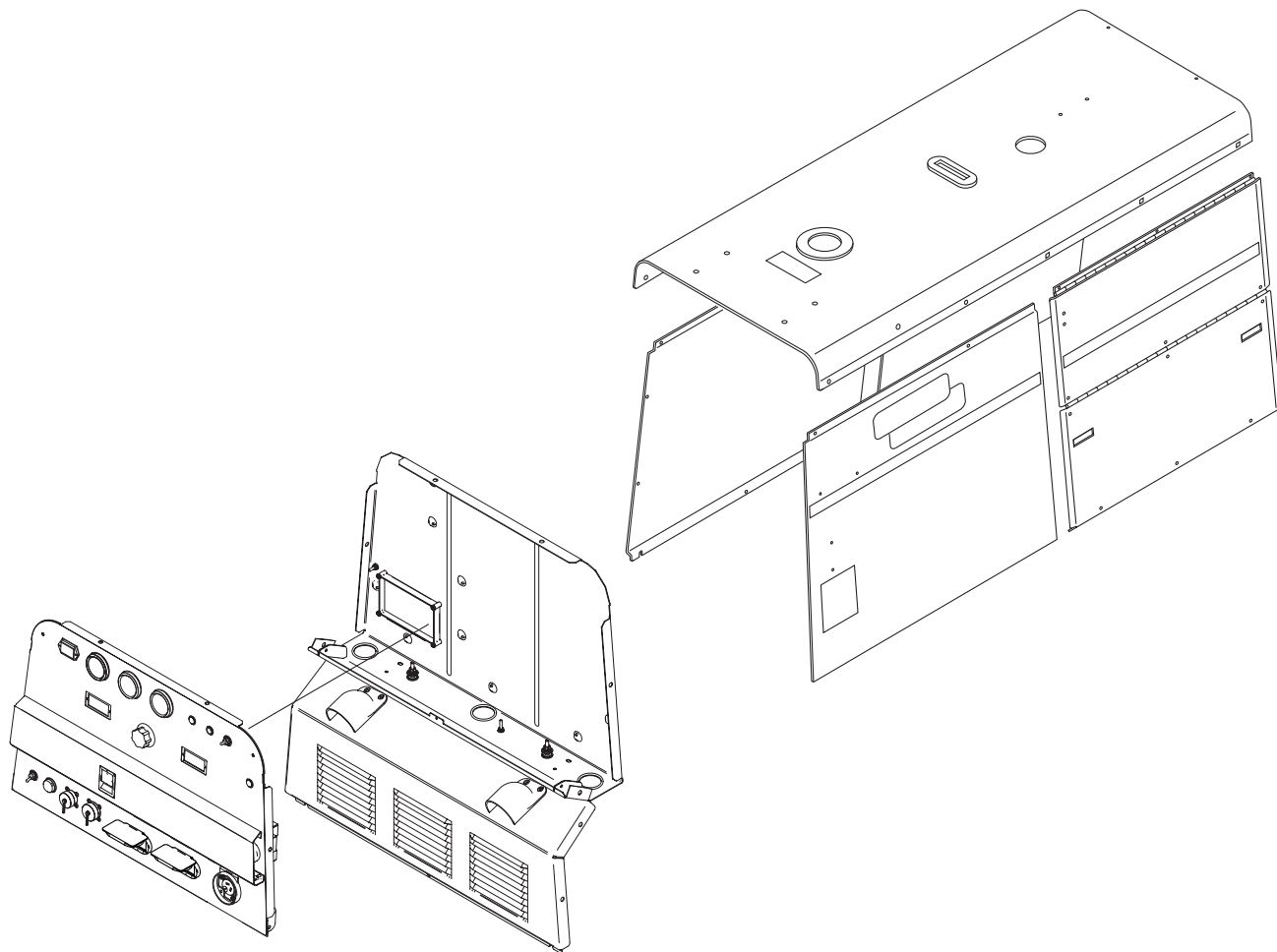

PROCEDURE

1. Turn the engine off.
2. Using the 3/8" wrench, remove the screws holding the front control panel to the case top and sides.
3. Carefully lower the front control panel.
4. Using the 3/8" wrench, remove the front left and right side panels.
5. Using the 3/4" wrench, remove the internal leads from the output terminals. Insulate the leads.
6. Using the 3/8" wrench, remove the screws holding the lower front panel (output panel) to the case front assembly. Then remove the front two screws holding the top of the panel. These are accessed in the control box, on the bottom at each side of the box. See Figure F.10. Carefully move the lower front panel to the right side. Note the green ground lead will still be attached.

AUXILIARY POWER AND WELD WINDINGS TEST

Start the engine and run at high idle (1900 RPM). Do not load welding or auxiliary power. See **Figure F11** and the appropriate Wiring Diagram for test points.

Single Phase Auxiliary Machines

1. Check for 115-132VAC from:
 - Lead 6B on CB4 to lead 5B at Receptacle J12.
 - Leads 3A on CB3 to Lead 5B at Receptacle J12.
2. Check for 230 to 264VAC from lead 3A on CB3 to lead 6B on CB4.

Three Phase Auxiliary Machines

1. Check for 230 to 246VAC from lead 3 to 6 on CB1.
2. Check for 230 to 246VAC from lead 3 to 4 on CB1.
3. Check for 230 to 246VAC from lead 4 to 6 on CB1.
4. Check for 115 to 132C from leads 3, 4, & 6 at CB1 to lead 5B at Receptacle J12.

FIGURE F.12 – OUTPUT RECTIFIER DIODE BRIDGE

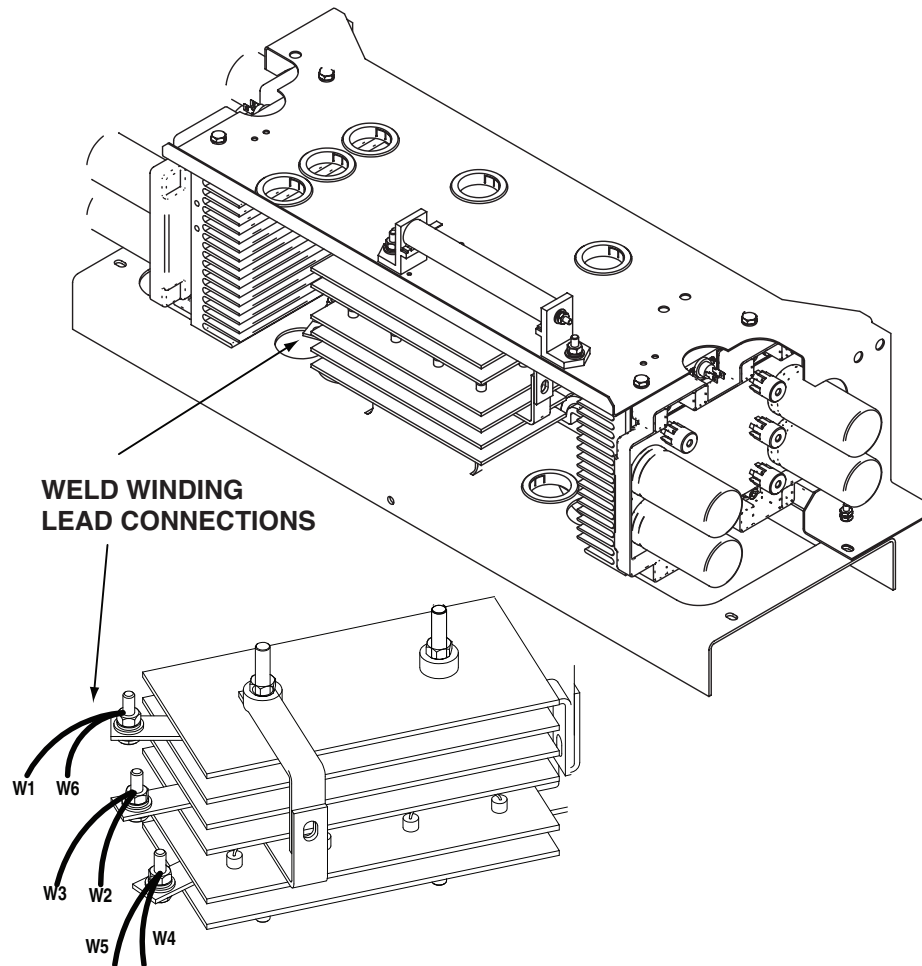

1. Locate the weld winding leads connected to the three-phase output rectifier diode bridge. See Figure F.12.
2. Check for approximately 68VAC from:
 - W1/W6 to W2/W3.
 - W1/W6 to W4/W5
 - W2/W3 to W4/W5
3. If any of these voltages are low or missing perform the **Flashing and Rotor Voltage Test** and also the **Rotor Resistance Test**.
4. Also check leads #6F and #5P for loose or faulty connections to the field bridge. See the Wiring Diagram.
5. If the tests in Steps 6 and 7 are OK and the stator voltages are low or missing, the stator may be faulty.
6. Replace the lower front panel and output leads.
7. Replace the upper control panel and secure.
8. Replace the front left and right case sides.

OUTPUT RECTIFIER BRIDGE TEST**⚠ WARNING**

Service and repair should be performed by only Lincoln Electric factory trained personnel. Unauthorized repairs performed on this equipment may result in danger to the technician or machine operator and will invalidate your factory warranty. For your safety and to avoid electrical shock, please observe all safety notes and precautions detailed throughout this manual.

If for any reason you do not understand the test procedures or are unable to perform the test/repairs safely, contact the Lincoln Electric Service Department for electrical troubleshooting assistance before you proceed. Call 1-888-935-3877.

TEST DESCRIPTION

This test will determine if the rectifier is grounded, or if there are any failed diode groups.

NOTE: This test will not be able to detect individual open diodes within a group.

MATERIALS NEEDED

- Miscellaneous hand tools
- Analog Ohmmeter or diode tester (For testing diodes)
- Ohm meter (any type for ground test)

FIGURE F.13 – DOOR REMOVAL

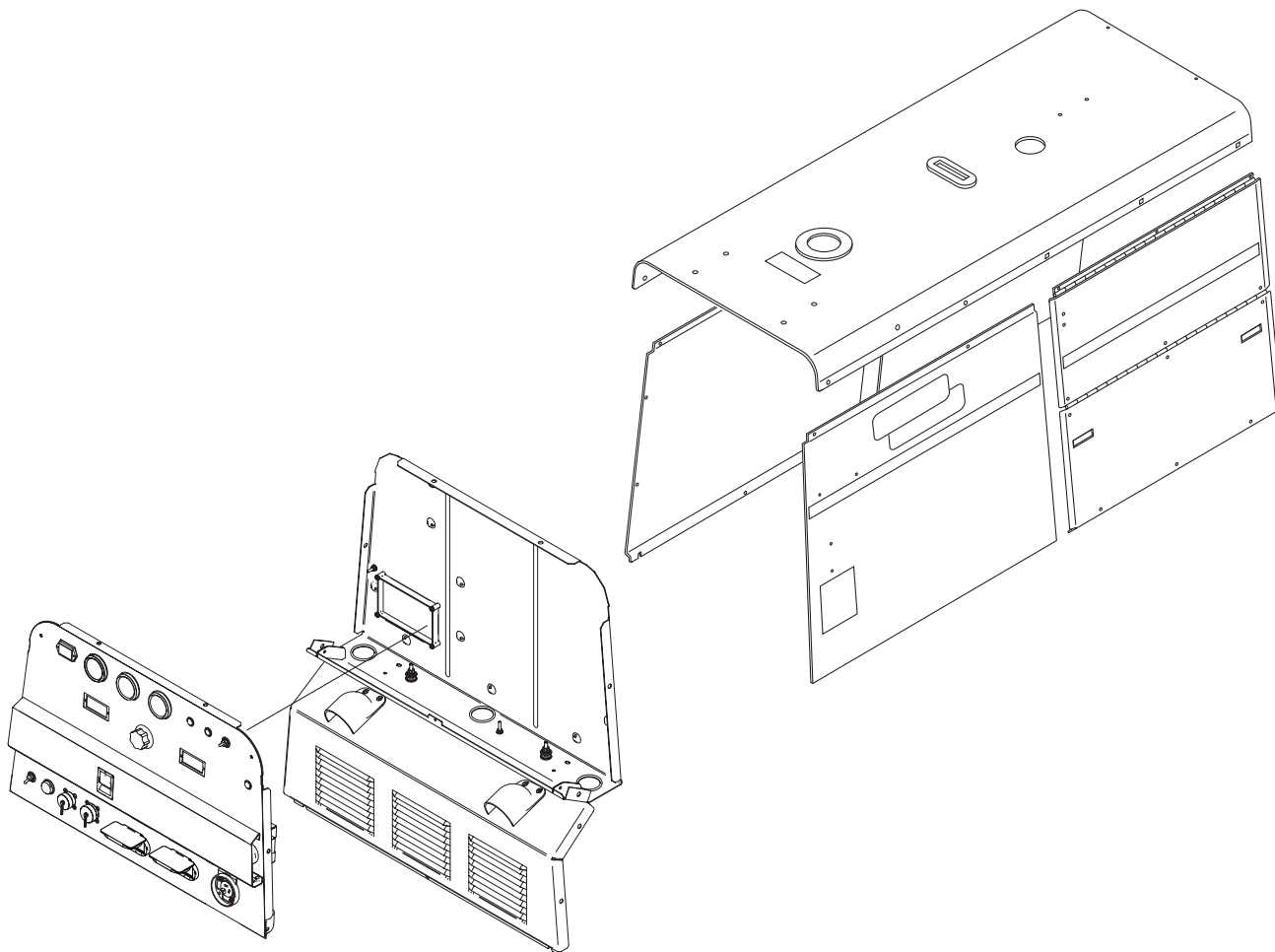

PROCEDURE

1. Turn the engine off.
2. Perform **Case Cover Removal Procedure**.
3. Perform **Chopper Module Capacitor Discharge Procedure**.
4. Using the 3/8" wrench, remove the three screws holding the lower front panel (output panel) to the case front assembly. Then remove the front two screws holding the top of the panel. These are accessed in the control box, on the bottom at each side of the box. Using the 7/16" wrench, disconnect the green ground lead. See Figure F.13. Carefully move the lower front panel to the right side.
5. Disconnect Bypass PC board leads #206B and #208 from their in-line connectors.
6. **Electrically isolate the three-phase input terminals of the output bridge rectifier as follows:**

Mark leads W1, W2, and W3 so they can be properly reconnected after the test is complete. Remove these leads and position them so they do not come in contact with any part of the rectifier. See the wiring diagram.

7. **Electrically isolate the DC output terminals of the rectifier:**

Mark the leads connected to the positive and negative terminals of the output bridge rectifier to assure that they can be reconnected properly. See **Figure F.14**.

8. Remove leads W4, W5, and W10 from the positive terminal of the rectifier, and remove leads W6 and W11 from the negative terminal. Position these leads so they do not come in contact with any part of the rectifier. See the wiring diagram and **Figure F.14**.

FIGURE F.14 – DIODE LEAD REMOVAL

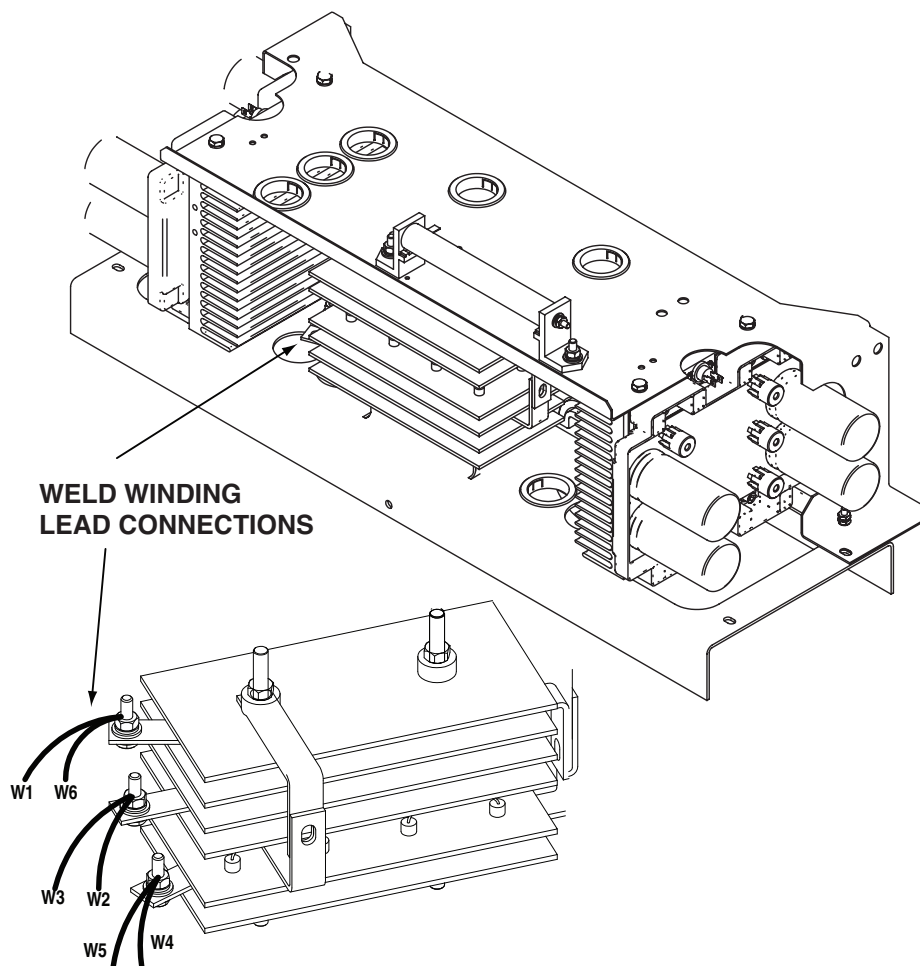

9. Using the 7/16" wrench, remove the stator leads from the three AC terminals. Label leads for reassembly. Note leads and AC terminals placement for reassembly. See **Figure F.15**.
10. Electronically isolate the 3 AC terminals leads by carefully bending them out into "free air"
11. With an ohmmeter or diode tester, check each of the 3 AC terminals to their respective heat sinks.
12. Reverse the tester leads and check the diodes again. Diodes should have a low resistance in one polarity and very high resistance in the opposite polarity. See diode test **Table F.2**.
 - * One open diode will not be detected.
13. Replace rectifier bridge if any "shorted" or "open" diode as tests indicate.
14. Replace the AC terminals and stator leads. Assemble the washers and nuts.
15. Replace the lower front panel and output leads.
16. Replace the upper control panel and secure.
17. Replace the front left and right case sides.
 - * One open diode will not be detected.

TROUBLESHOOTING AND REPAIR

OUTPUT RECTIFIER BRIDGE TEST (CONTINUED)

FIGURE F.15 – DIODE LEAD REMOVAL

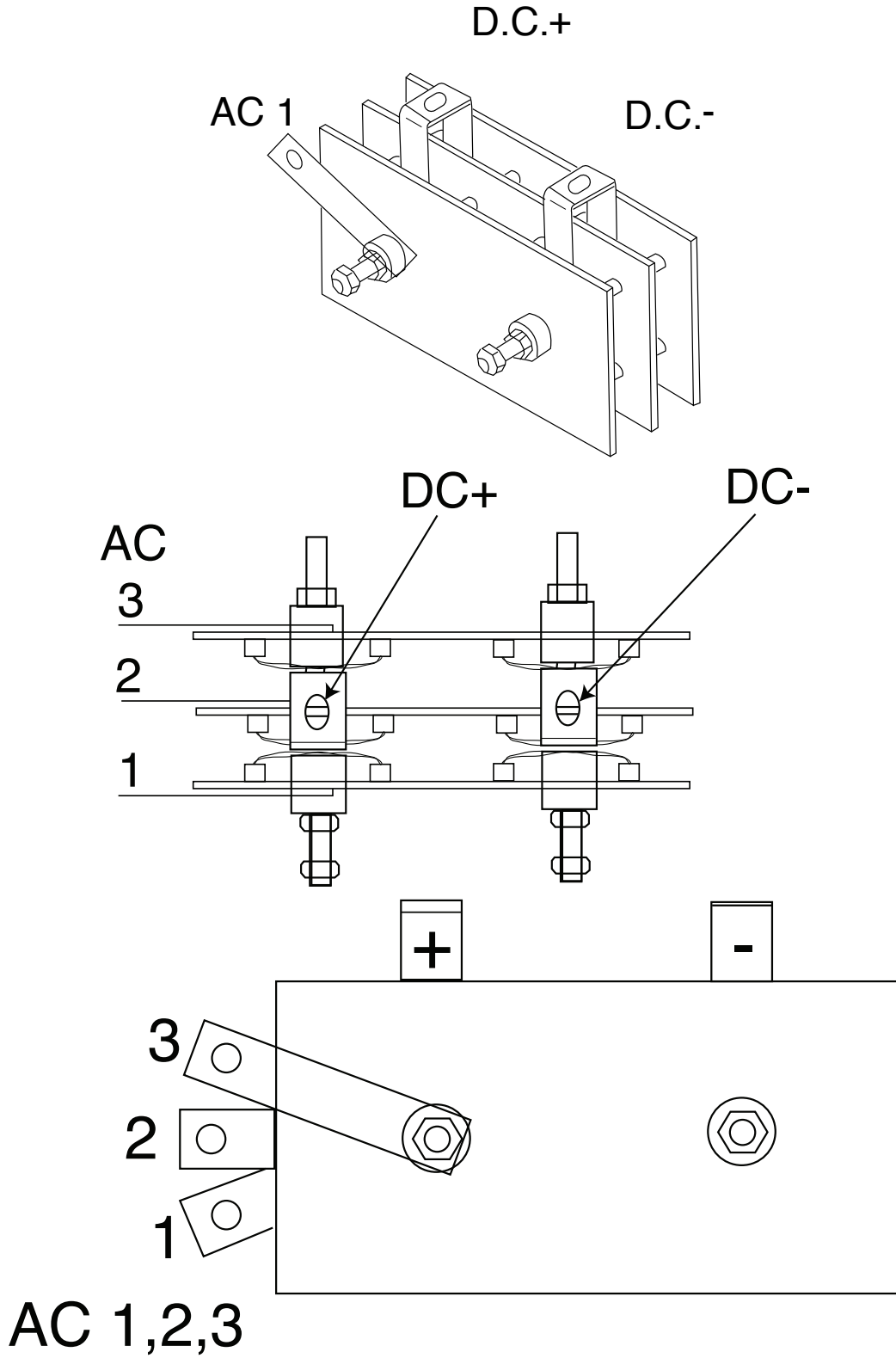

Return to Section TOC

Return to Section TOC

Return to Section TOC

Return to Section TOC

Return to Master TOC

Return to Master TOC

Return to Master TOC

Return to Master TOC

OUTPUT RECTIFIER BRIDGE TEST (CONTINUED)

TABLE F.2 – DIODE TEST TABLE

RECTIFIER TERMINAL CONNECTIONS	DIODE TEST		
	TEST INSTRUMENT		DIODE BIAS & EXPECTED TEST RESULT
	(+) Lead	(-) Lead	
	AC1	DC(+)	Forward Bias (Low Resistance)
	AC2	DC(+)	Forward Bias (Low Resistance)
	AC3	DC(+)	Forward Bias (Low Resistance)
	DC(-)	AC1	Forward Bias (Low Resistance)
	DC(-)	AC2	Forward Bias (Low Resistance)
	DC(-)	AC3	Forward Bias (Low Resistance)
	AC1	DC(-)	Reverse Bias (High Resistance)
	AC2	DC(-)	Reverse Bias (High Resistance)
	AC3	DC(-)	Reverse Bias (High Resistance)
	DC(+)	AC1	Reverse Bias (High Resistance)
	DC(+)	AC2	Reverse Bias (High Resistance)
	DC(+)	AC3	Reverse Bias (High Resistance)

- 18. Reconnect all leads.
- 19. Perform the ***Case Cover Replacement Procedure***.

Return to Section TOC

Return to Master TOC

Return to Section TOC

Return to Section TOC

Return to Section TOC

Return to Section TOC

Return to Master TOC

Return to Master TOC

Return to Master TOC

Return to Master TOC

VANTAGE® 500



ELECTRONIC GOVERNOR TEST**⚠ WARNING**

Service and repair should be performed by only Lincoln Electric factory trained personnel. Unauthorized repairs performed on this equipment may result in danger to the technician or machine operator and will invalidate your factory warranty. For your safety and to avoid electrical shock, please observe all safety notes and precautions detailed throughout this manual.

If for any reason you do not understand the test procedures or are unable to perform the test/repairs safely, contact the Lincoln Electric Service Department for electrical troubleshooting assistance before you proceed. Call 1-888-935-3877.

TEST DESCRIPTION

This test will help determine if the Electronic Governor is operating properly.

MATERIALS NEEDED

Volt/Ohmmeter (Analog)
Miscellaneous Hand Tools

NOTE: Because the Vantage® 500 uses several different models of both Cummins and Deutz engines, the removal and replacement procedures may vary from the descriptions in this manual. Refer to the engine manufacturer's manuals for more specific information.

ELECTRONIC GOVERNOR TEST (CONTINUED)

TEST PROCEDURE

CHECK CONTROLLER

1. Turn the Run/Stop switch to Run. Do not start engine.
2. The engine protection light should be ON for 5 seconds then go out.
3. After 30 additional seconds the light should come back on.
4. If a-c or 1-3 are OK then the controller is probably good.
5. If the engine protection light stays ON, controller may be defective.
6. Turn the Run/Stop switch to Stop.

CHECK FUEL CONTROL LEVER ACTUATOR

1. Disconnect leads 270 and 271 from actuator leads.
2. Measure 2 to 2.5 ohms between actuator leads.
3. Reconnect leads 270 and 271 to the actuator leads.

CHECK MAG PICK-UP

1. Disconnect shielded cable leads from the magnetic pick-up leads.
2. Measure 200-220 Ohms between the mag pick-up leads.
3. Set the voltmeter for VAC with a max scale of 4 volts.
4. Disconnect leads 262 from the fuel solenoid so the engine cannot start.
5. Measure 1 to 2 VAC while engine is cranking.
6. If ohms and volts are OK mag pick-up is working properly.
7. If ohms are OK, but the voltage is less than 1 volt mag pick-up may be defective or need adjustment.
8. Correct adjustment of pick-up is .015 to .020 inch gap from flywheel teeth (approx. 1/2 turn from just touching the teeth).
9. Reconnect shielding cable leads to mag pick-up leads and lead 262 to engine fuel solenoid.

CHECK AND ADJUST FUEL CONTROL LEVER AND ACTUATOR LINKAGE

1. Disconnect actuator linkage rod from fuel control lever at injection pump.
2. Loosen lock nut on fuel lever off stop screw.
3. Adjust fuel lever stop screw clockwise (down) until engine will just start and run slowly while holding fuel lever against stop screw. CAUTION: DO NOT ALLOW FUEL LEVER TO GO FULL ON AS ENGINE OVERSPEED WILL OCCUR.
4. While holding fuel lever against the stop screw slowly turn stop screw counterclockwise (up) until engine just stops. Adjust additional 1/2 turn up and tighten lock nut.
5. Check actuator for freedom of movement and proper return spring operation. Linkage should not bind or rub on anything.
6. Adjust actuator rod length so that at rest the attachment hole lines up with the hole in the fuel control lever when it is against the off stop. Shorten the rod by 1 to 2 turns of the adjustment clevis and reattach to the fuel control lever.
7. At rest the actuator should just hold the fuel control lever against the off stop.
8. If the rod is too long engine speed regulation can be sluggish, overspeeding can occur and engine protection function may not work.
9. If the rod is too short, engine starting may be difficult or impossible.
10. Repeat steps until engine starts and stops properly.
11. For a final check of the linkage while engine is running manually push and hold actuator linkage against fuel lever off stop and verify engine does stop.

CHARGING CIRCUIT TEST**⚠ WARNING**

Service and repair should be performed by only Lincoln Electric factory trained personnel. Unauthorized repairs performed on this equipment may result in danger to the technician or machine operator and will invalidate your factory warranty. For your safety and to avoid electrical shock, please observe all safety notes and precautions detailed throughout this manual.

If for any reason you do not understand the test procedures or are unable to perform the test/repairs safely, contact the Lincoln Electric Service Department for electrical troubleshooting assistance before you proceed. Call 1-888-935-3877.

TEST DESCRIPTION

This test will determine if the engine alternator and associated circuitry are functioning properly.

MATERIALS NEEDED

3/8" Wrench
Volt/Ohmmeter
Wiring Diagram

NOTE: Because the Vantage® 500 uses several different models of both Cummins and Deutz engines, the removal and replacement procedures may vary from the descriptions in this manual. Refer to the engine manufacturer's manuals for more specific information.

FIGURE F.16 – ENGINE ALTERNATOR LOCATION (DEUTZ 10995)

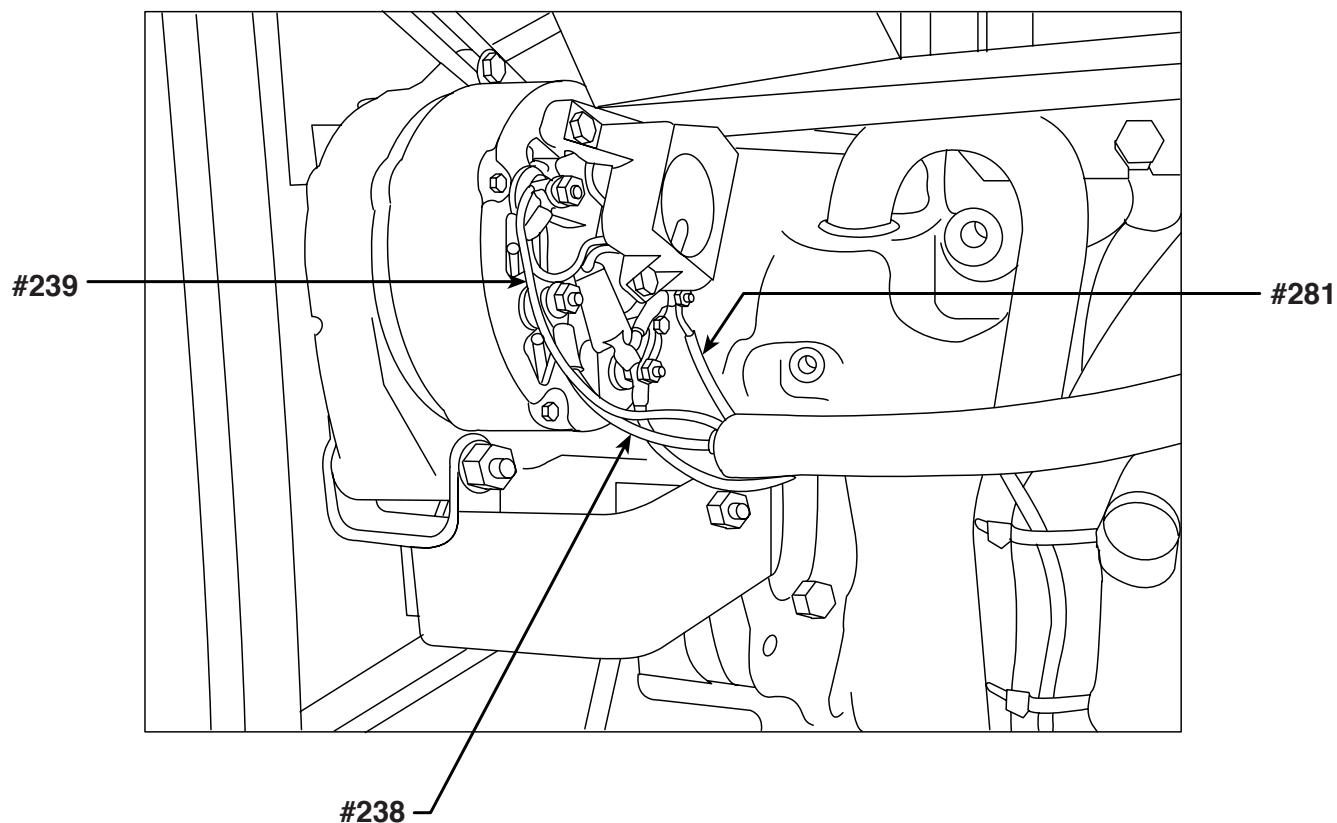

PROCEDURE

1. Turn engine off.
 2. Using the 3/8" wrench, remove the left rear case cover. (remove right rear case cover for Cummins engine 10996)
 3. Locate the engine alternator. See Figure F.16.
 4. Start the engine and run it at high idle (1900 RPM).
 5. Set the voltmeter for DC volts and measure the DC volts at lead #239 (Deutz) to engine ground. See the Wiring Diagram. Normal is 13.2 to 14.5VDC.
 6. Set the voltmeter for DC volts and measure the DC volts at lead #238 to engine ground. See the Wiring Diagram. Normal is 13.2 to 14.5VDC.
 7. Set the voltmeter for DC volts and measure the DC volts at lead #281 (#232 Cummins) to engine ground. See the Wiring Diagram. Normal is 13.2 to 14.5 VDC.
- NOTE:** Lead #281 (#232 Cummins) carries the flashing voltage for the engine alternator. Battery voltage should be present whenever the engine is off. See the Wiring Diagram.
8. If the correct flashing voltage is present and the charging output voltage is low or missing, the engine alternator may be faulty.
 9. Stop the engine and check the alternator V-belt for proper tension. See the engine operation manual.
 10. Replace the left rear case cover.

NORMAL OPEN CIRCUIT VOLTAGE WAVEFORM (STICK)

MAX TAP – MAX CONTROL POT – HIGH IDLE – NO LOAD

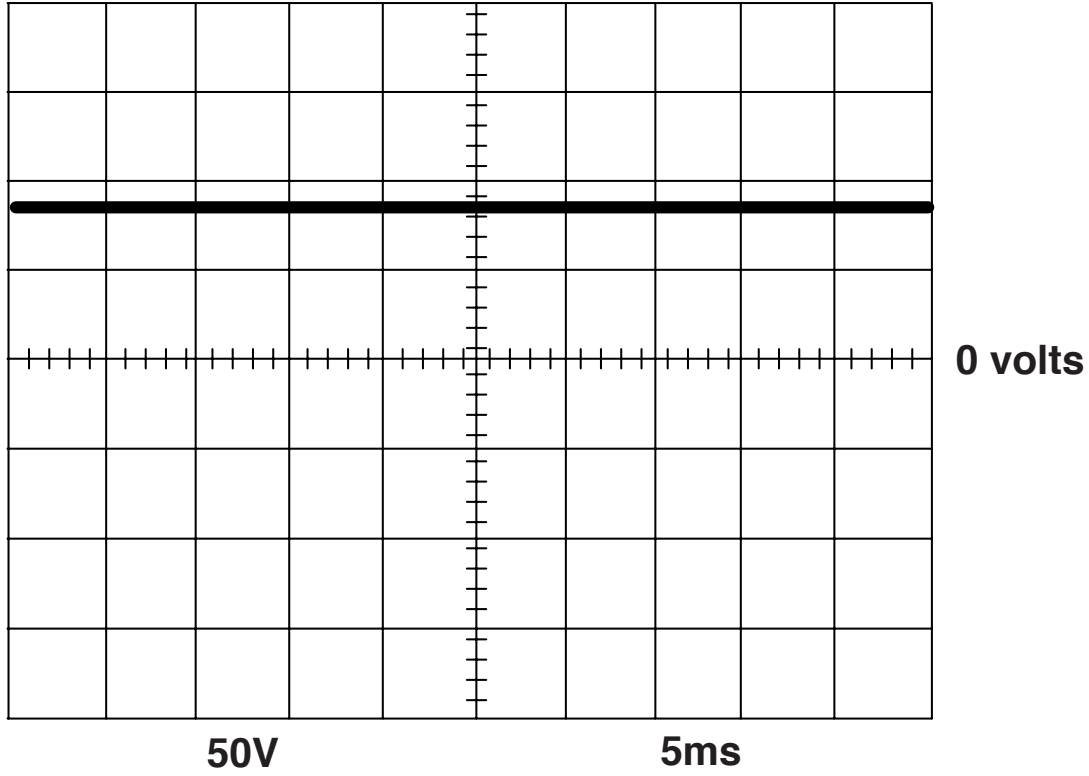

This is the typical DC open circuit output voltage generated from a properly operating machine in the Constant Current (CC) mode.

Note that each vertical division represents 50 volts and that each horizontal division represents 5 milliseconds in time.

SCOPE SETTINGS

Volts/Div	50V/Div.
Horizontal Sweep	5 ms/Div.
Coupling	DC
Trigger	Internal

VANTAGE® 500



Return to Section TOC

Return to Master TOC

Return to Section TOC

Return to Master TOC

Return to Section TOC

Return to Master TOC

Return to Section TOC

Return to Master TOC

NORMAL WELD VOLTAGE WAVEFORM (STICK CC)

MACHINE LOADED TO 500 AMPS AT 40 VOLTS

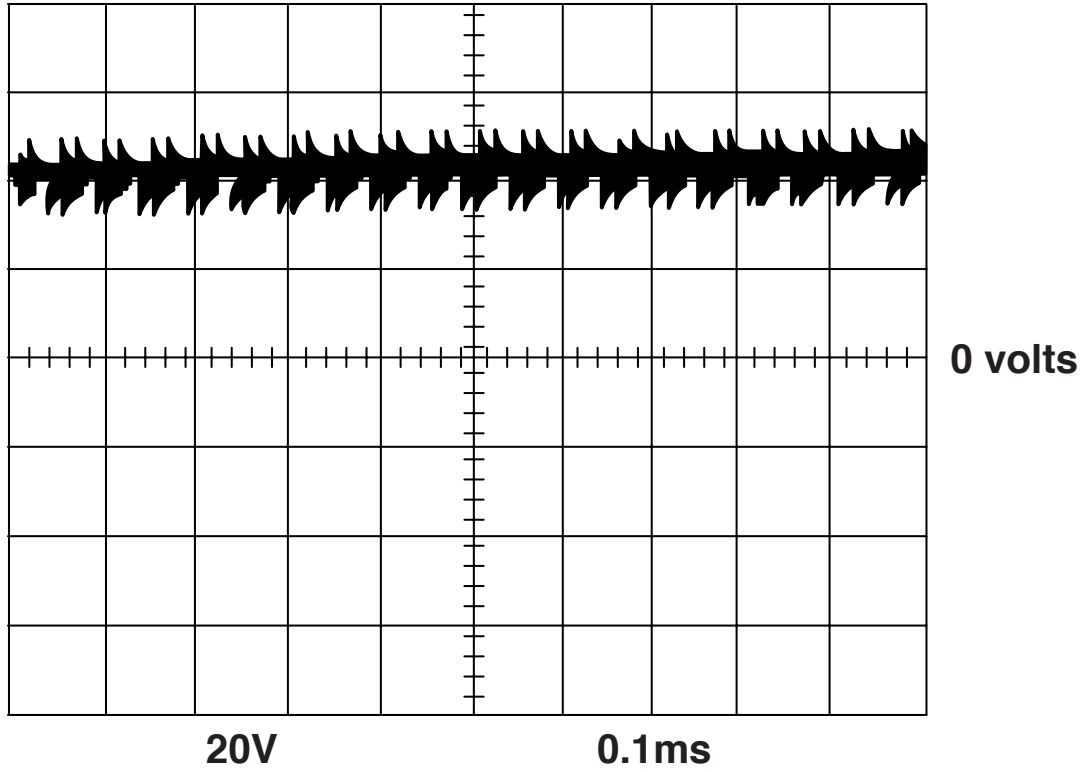

This is the typical DC output voltage generated from a properly operating machine in the Constant Current (CC) mode.

Note that each vertical division represents 20 volts and that each horizontal division represents 0.1 milliseconds in time.

The machine was loaded with a resistance grid bank to 500 amps at 40 volts.

SCOPE SETTINGS

Volts/Div20V/Div.
 Horizontal Sweep...0.1 ms/Div.
 Coupling.....DC
 Trigger.....Internal

VANTAGE® 500



Return to Section TOC
 Return to Section TOC
 Return to Section TOC
 Return to Section TOC
 Return to Master TOC
 Return to Master TOC
 Return to Master TOC
 Return to Master TOC

TROUBLESHOOTING AND REPAIR

NORMAL TIG MODE VOLTAGE WAVEFORM

LOADED TO 200A 16 VOLTS

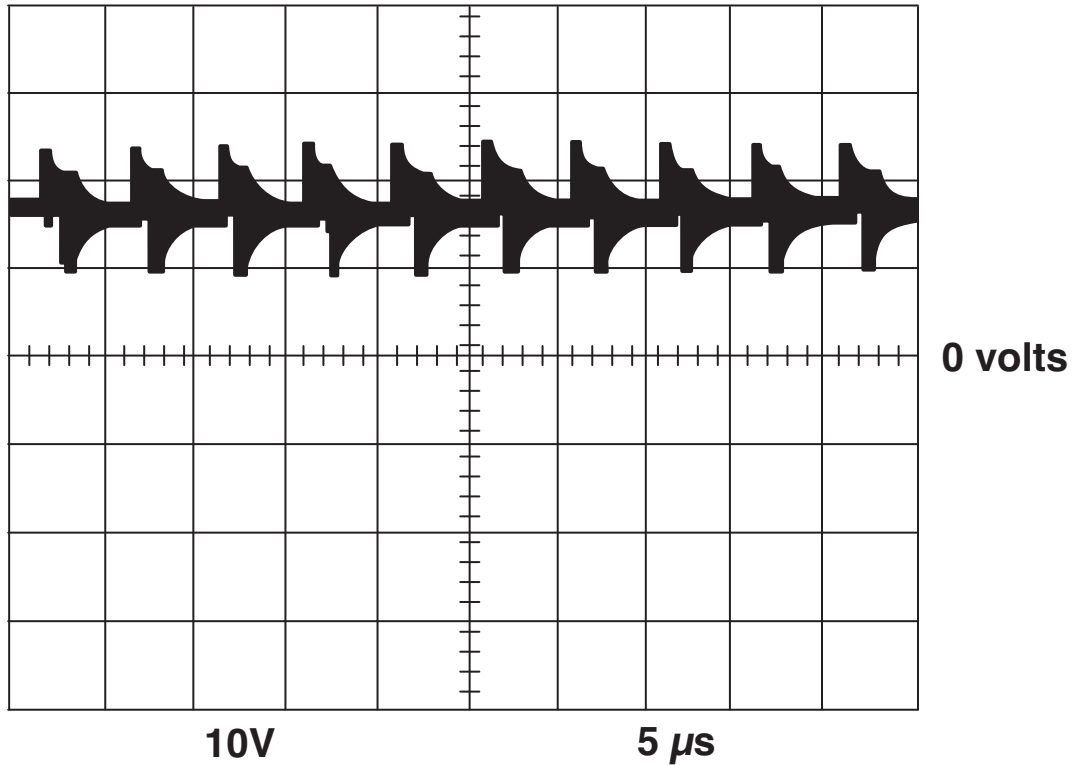

This is the typical output voltage generated from a properly operating machine in the TIG Mode.

Note that each vertical division represents 10 volts and that each horizontal division represents 50 microseconds in time.

The machine was loaded with a resistance grid bank to 200 amps at 16 VDC.

SCOPE SETTINGS

Volts/Div10V/Div.
 Horizontal Sweep....05 ms/Div.
 Coupling.....DC
 Trigger.....Internal

VANTAGE® 500



Return to Section TOC
 Return to Section TOC
 Return to Section TOC
 Return to Section TOC
 Return to Master TOC
 Return to Master TOC
 Return to Master TOC
 Return to Master TOC

NORMAL OPEN CIRCUIT VOLTAGE WAVEFORM (WIRE CV)

HIGH IDLE - NO LOAD

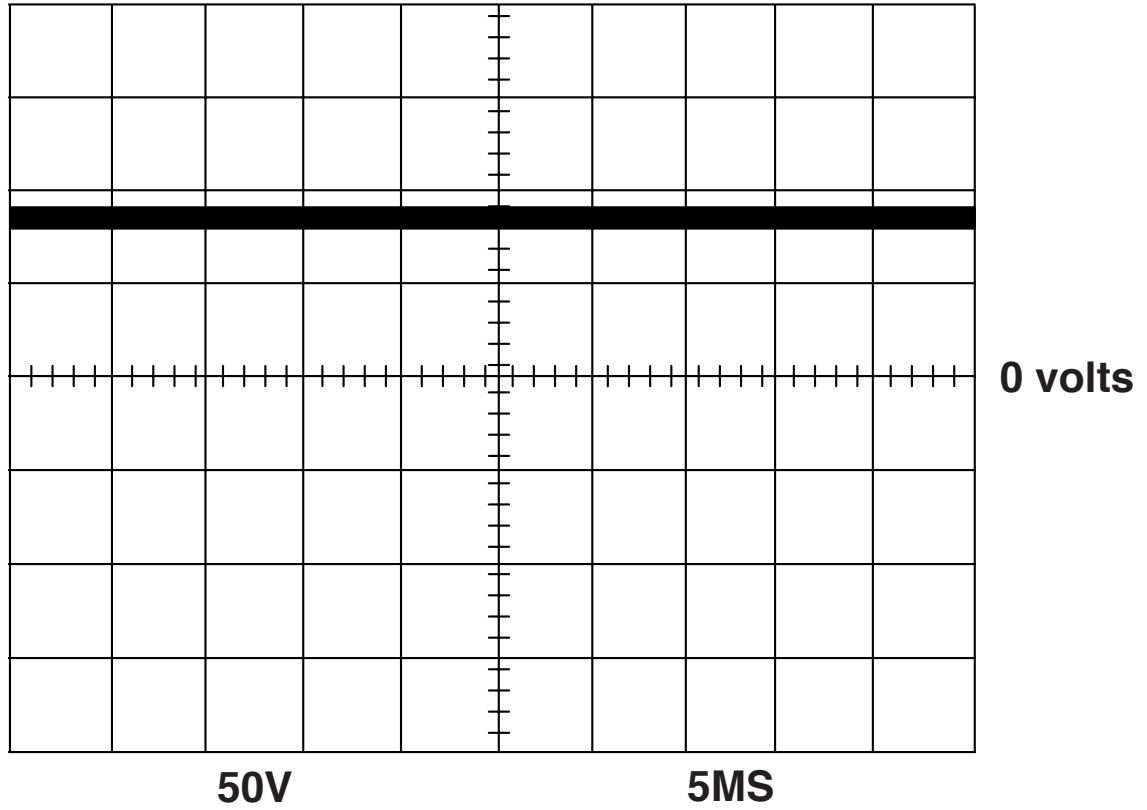

This is the typical auxiliary output voltage generated from a properly operating machine in the CV mode.

Note that each vertical division represents 50 volts and that each horizontal division represents 5 milliseconds in time.

SCOPE SETTINGS

Volts/Div	50V/Div.
Horizontal Sweep	5 ms/Div.
Coupling	DC
Trigger	Internal

Return to Section TOC
Return to Section TOC
Return to Section TOC
Return to Section TOC
Return to Master TOC
Return to Master TOC
Return to Master TOC
Return to Master TOC

NORMAL WELD VOLTAGE WAVEFORM (WIRE CV)

MACHINE LOADED TO 500 AMPS AT 40 VOLTS

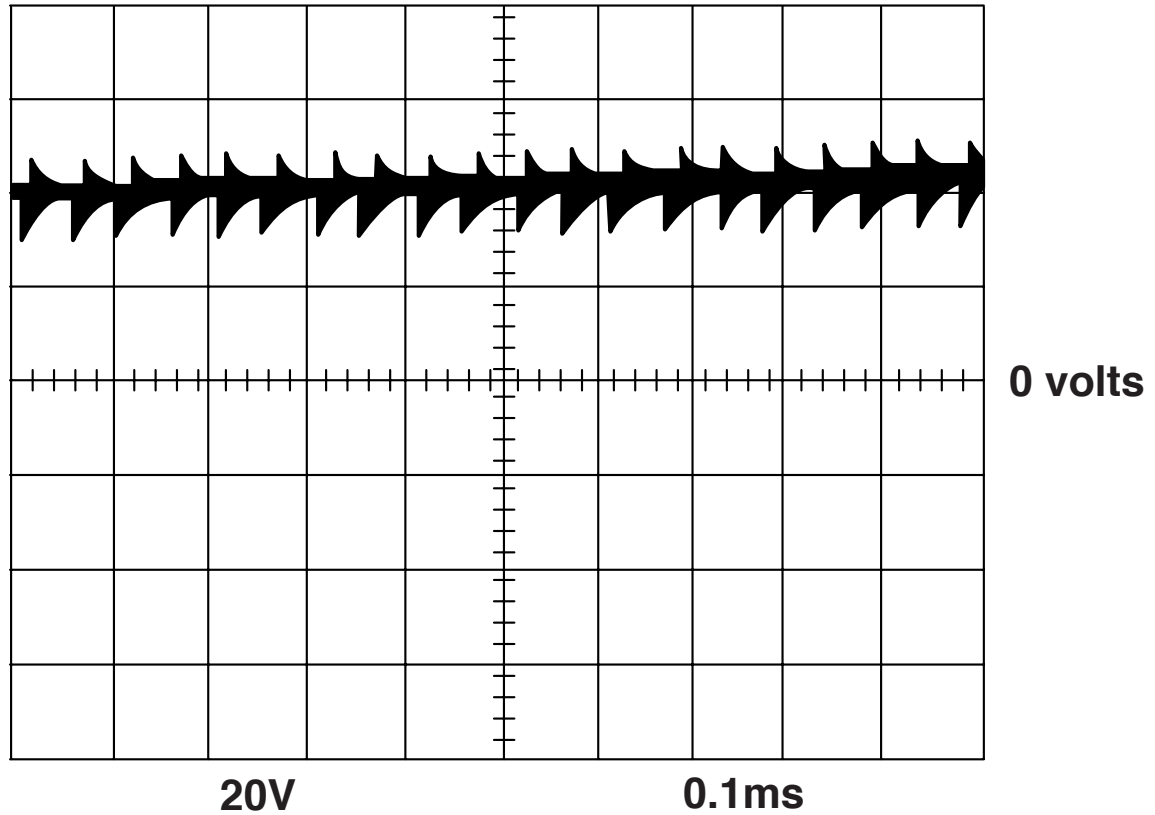

This is the typical DC output voltage generated from a properly operating machine in the Constant Voltage (CV) mode.

Note that each vertical division represents 20 volts and that each horizontal division represents 5 milliseconds in time.

The machine was loaded with a resistance grid bank to 500 amps at 40 volts.

SCOPE SETTINGS

Volts/Div20V/Div.
 Horizontal Sweep...0.1ms/Div.
 Coupling.....DC
 Trigger.....Internal

VANTAGE® 500



Return to Section TOC
 Return to Section TOC
 Return to Section TOC
 Return to Section TOC
 Return to Master TOC
 Return to Master TOC
 Return to Master TOC
 Return to Master TOC

SHUTDOWN SOLENOID REMOVAL AND REPLACEMENT

WARNING

Service and repair should be performed by only Lincoln Electric factory trained personnel. Unauthorized repairs performed on this equipment may result in danger to the technician or machine operator and will invalidate your factory warranty. For your safety and to avoid electrical shock, please observe all safety notes and precautions detailed throughout this manual.

If for any reason you do not understand the test procedures or are unable to perform the test/repairs safely, contact the Lincoln Electric Service Department for electrical troubleshooting assistance before you proceed. Call 1-888-935-3877.

TEST DESCRIPTION

This procedure will aid the technician in the removal and replacement of the shutdown solenoid.

MATERIALS NEEDED

- 7/16" Wrench, 10mm wrench
- Long slot head screwdriver
- Needle nose pliers

NOTE: Because the Vantage® 500 uses several different models of both Cummins and Deutz engines, the removal and replacement procedures may vary from the descriptions in this manual. Refer to the engine manufacturer's manuals for more specific information.

SHUTDOWN SOLENOID REMOVAL AND REPLACEMENT (DEUTZ)

FIGURE F.17 – SHUTDOWN SOLENOID LEAD CONNECTIONS

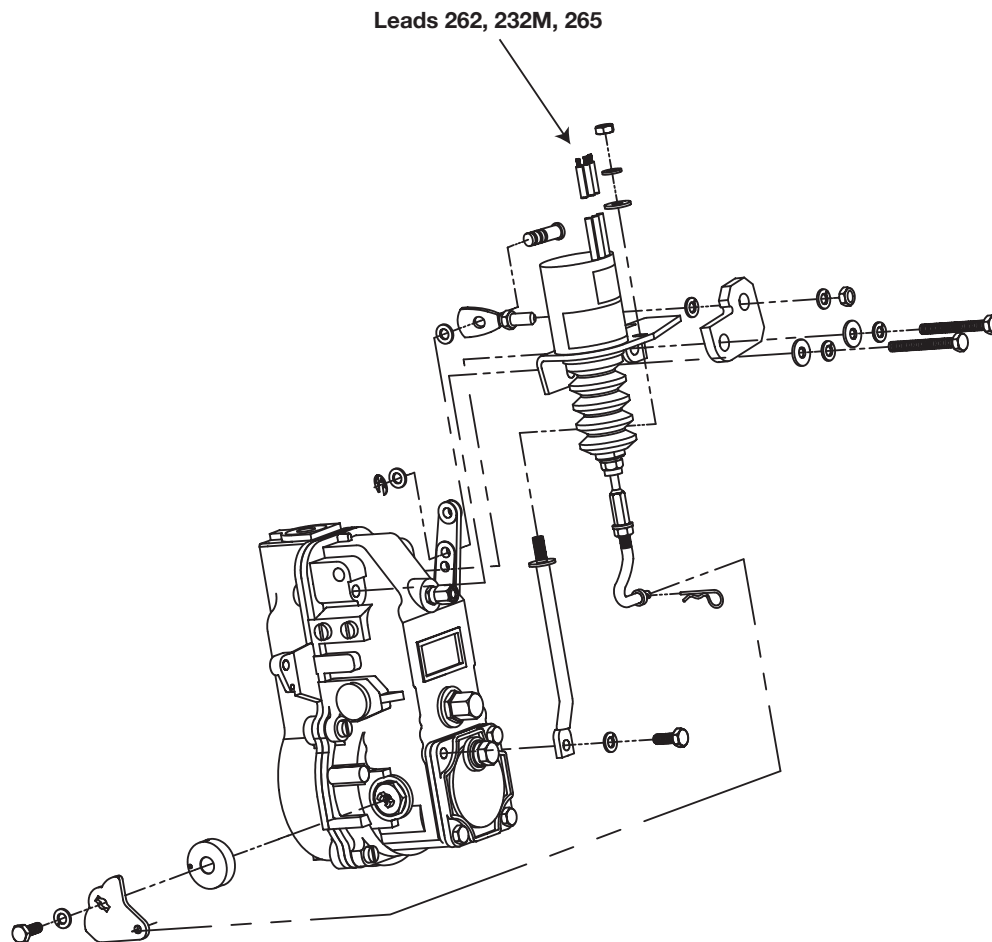
**PROCEDURE**

1. Turn engine off.
2. Unlatch, lift and secure the engine access door.
3. Locate and remove the spade connectors that attach the shutdown solenoid terminals to the wiring harness leads. Cut the cable tie.
4. Remove the bolts that mount shutdown solenoid assembly to engine.
5. Remove the pivot pin retaining ring and pivot pin from the solenoid linkage assembly.
6. Remove the solenoid assembly.
7. Replace any faulty or worn parts and reassemble the solenoid assembly.

REASSEMBLY

1. Reassemble the pivot pin and retaining ring to the linkage assembly
2. Remount the shutdown solenoid assembly to the engine.
3. Reattach the spade connectors from the wiring harness to the shutdown solenoid assembly. Replace the cable tie.
4. Close the engine access door.

SHUTDOWN SOLENOID REMOVAL AND REPLACEMENT (CUMMINS)

FIGURE F.18 – SHUTDOWN SOLENOID LINKAGE ARM ASSEMBLY

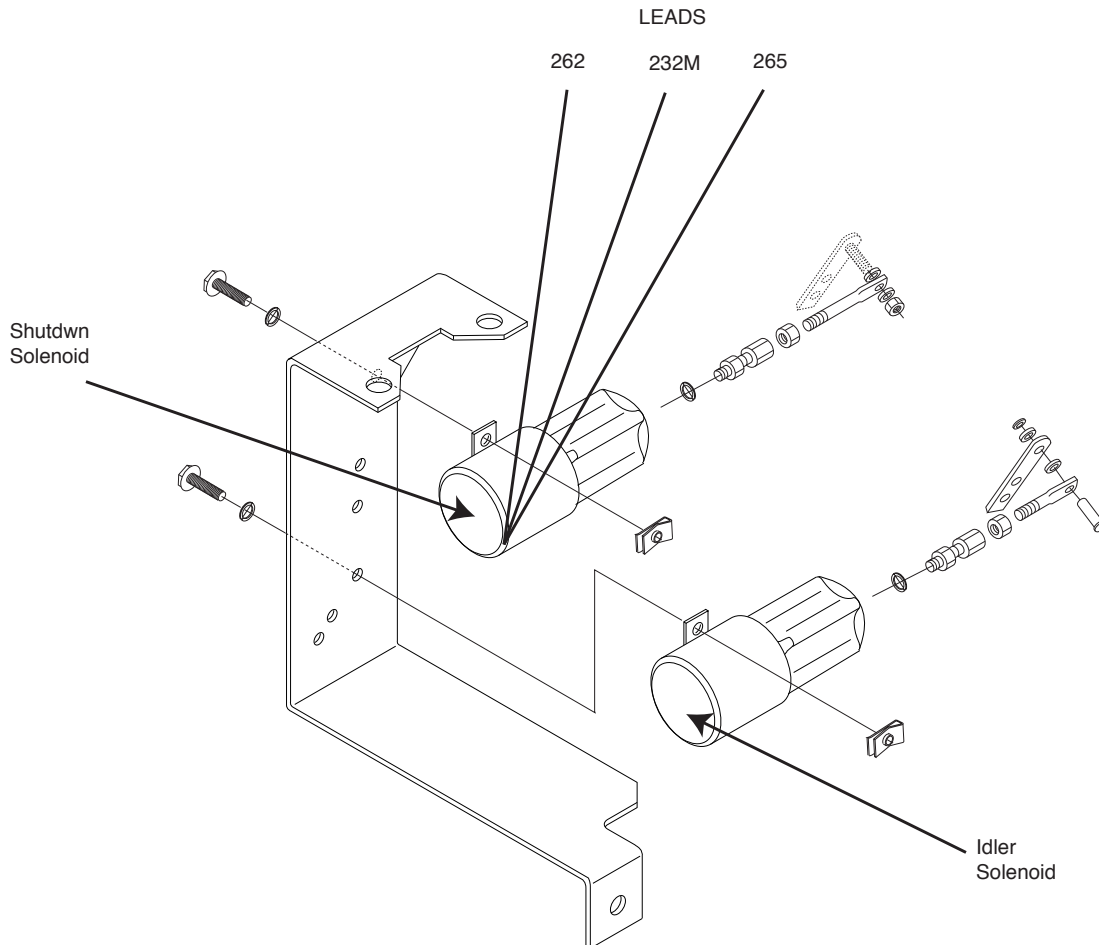
**PROCEDURE**

1. Turn engine off.
2. Unlatch, lift and secure engine access door.
3. Locate and remove the spade connectors that attach the shutdown solenoid terminals to the wiring harness leads. Cut the cable tie.
4. Remove the bolts that mount shutdown solenoid assembly to engine.
5. Remove the pivot pin retaining ring and pivot pin from the solenoid linkage assembly.
6. Remove the solenoid assembly.
7. Replace any faulty or worn parts and reassemble the solenoid assembly.

REASSEMBLY

1. Reassemble the pivot pin and retaining ring to the linkage assembly.
2. Remount the shutdown solenoid assembly to the engine.
3. Reattach the spade connectors from the wiring harness to the shutdown solenoid assembly. Replace the cable tie.
4. Close the engine access door.

Return to Section TOC
Return to Section TOC
Return to Section TOC
Return to Section TOC
Return to Master TOC
Return to Master TOC
Return to Master TOC
Return to Master TOC

VANTAGE® 500



OUTPUT RECTIFIER REMOVAL AND REPLACEMENT PROCEDURE

WARNING

Service and repair should be performed by only Lincoln Electric factory trained personnel. Unauthorized repairs performed on this equipment may result in danger to the technician or machine operator and will invalidate your factory warranty. For your safety and to avoid electrical shock, please observe all safety notes and precautions detailed throughout this manual.

If for any reason you do not understand the test procedures or are unable to perform the test/repairs safely, contact the Lincoln Electric Service Department for electrical troubleshooting assistance before you proceed. Call 1-888-935-3877.

TEST DESCRIPTION

The following procedure will aid the technician in removing and replacing stud type diodes to the aluminum heat sinks on the Vantage 500.

MATERIALS NEEDED

- 7/16" socket & ratchet
- 1/2" socket & ratchet

OUTPUT RECTIFIER REMOVAL AND REPLACEMENT PROCEDURE (continued)

FIGURE F.19 – DOOR REMOVAL

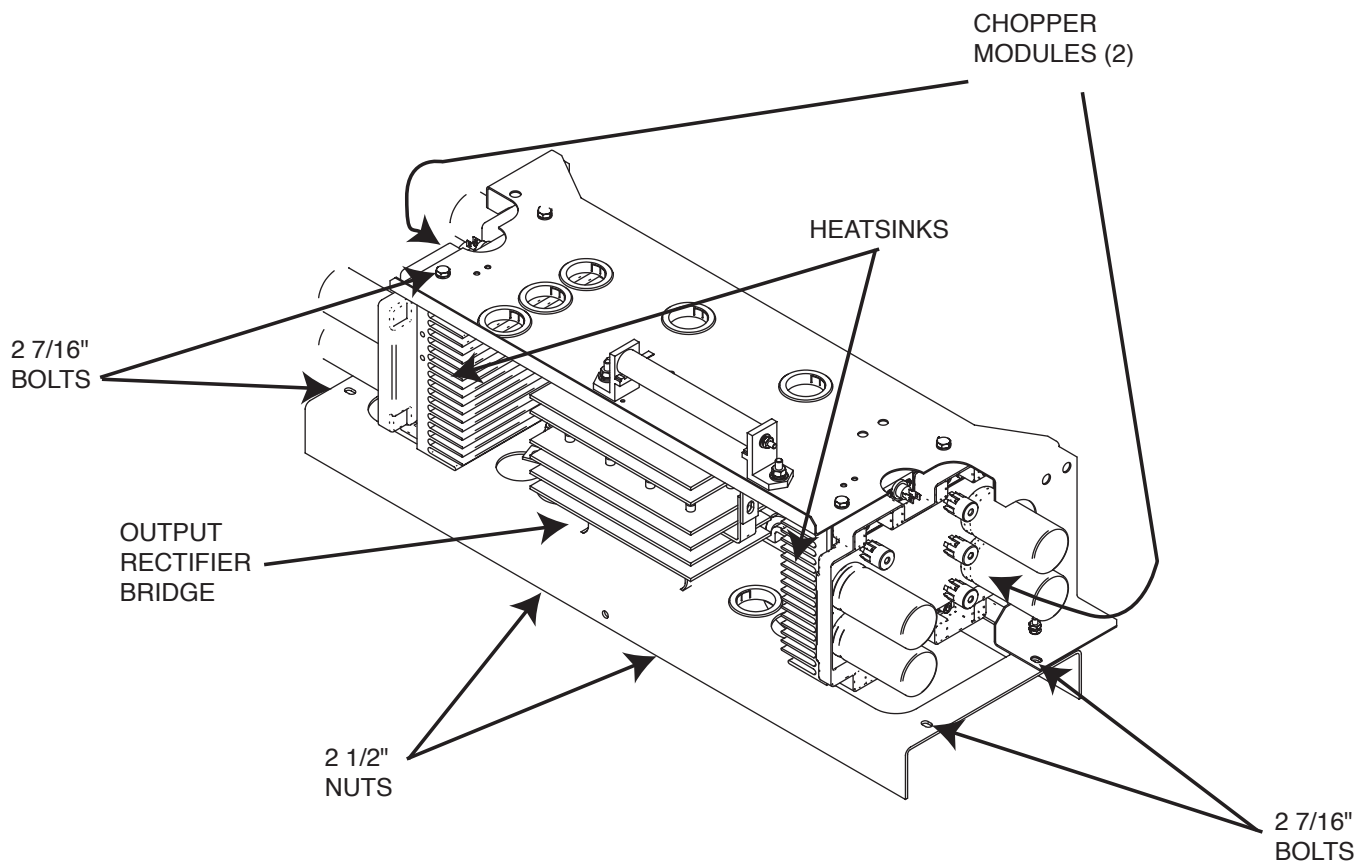

PROCEDURE

1. Turn the engine off.
2. Perform the output panel removal as described in the **Case Cover Removal** procedure.
3. Perform the **Chopper Module Capacitor Discharge** procedure.
4. Using the 7/16" wrench, remove the appropriate stator leads and AC terminals leads. Refer to Figure F.19. Label the leads for reassembly.
5. Using 7/16" socket remove 4 bolts holding power module assembly to base.
6. Remove power module assembly.
7. Using 1/2" socket, remove output rectifier assembly and replace.
8. Reverse procedure for assembly.

TROUBLESHOOTING AND REPAIR

STATOR/ROTOR REMOVAL AND REPLACEMENT

WARNING

Service and repair should be performed by only Lincoln Electric factory trained personnel. Unauthorized repairs performed on this equipment may result in danger to the technician or machine operator and will invalidate your factory warranty. For your safety and to avoid electrical shock, please observe all safety notes and precautions detailed throughout this manual.

If for any reason you do not understand the test procedures or are unable to perform the test/repairs safely, contact the Lincoln Electric Service Department for electrical troubleshooting assistance before you proceed. Call 1-888-935-3877.

TEST DESCRIPTION

The following procedure will aid the technician in removing and replacing the Vantage 500 stator and rotor.

MATERIALS NEEDED

5/16" Wrench	Slot head screw driver
3/8" Wrench	Phillips head screw driver
7/16" Wrench	Gear puller (small)
1/2" Wrench	Hoist
3/4" Wrench	Feeler gauge (for air gap check)
1" Open end wrench	
1 1/8" Wrench	
9/16" Deep socket wrench	
17mm Wrench	

VANTAGE® 500



STATOR/ROTOR REMOVAL AND REPLACEMENT (CONTINUED)

FIGURE F.20 – FUEL TANK REMOVAL DETAILS

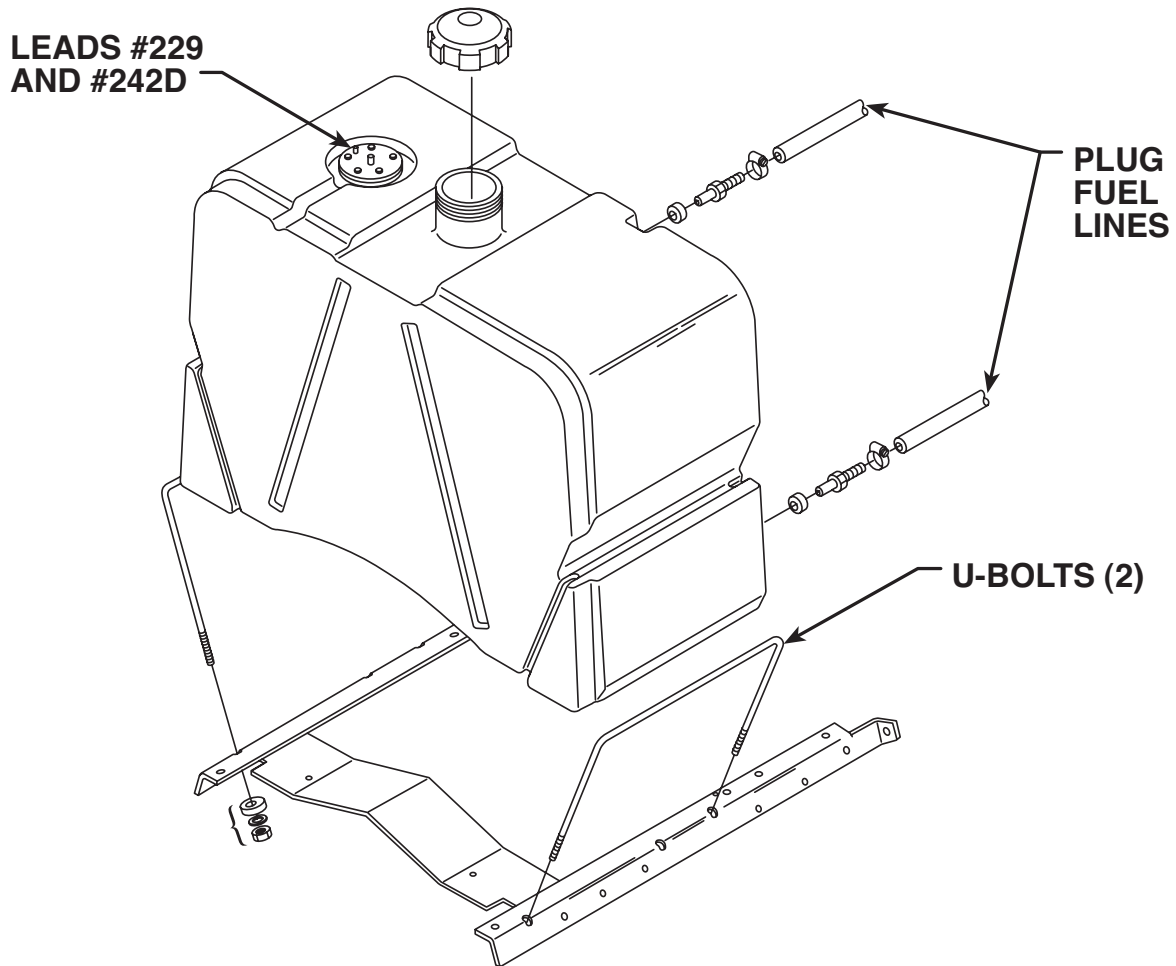

PROCEDURE

Refer to Figure F.20.

1. Turn the engine off and disconnect battery leads and drain fuel.
2. Perform the **Case Cover Removal** procedure, including removing the output panel.
3. Perform the **Chopper Module / Output Rectifier Bridge Assembly Removal Procedure**.
4. Perform the **Chopper Module Capacitor Discharge Procedure**.
5. Disconnect Battery.
6. Using the 3/8" wrench, remove leads #229 (white) and #242D from the fuel level sensor. Label the leads for reassembly.
7. Turn the fuel off at the shutoff valve. Remove and plug the fuel return line.
8. Remove and plug the lower fuel line. Pull it through the firewall.
9. Using the 9/16" deep socket wrench, remove the four lock nuts, washers, and rubber washers from the fuel tank mounting U-bolts.
10. Carefully remove the U-bolts and lift the fuel tank from the machine.

STATOR/ROTOR REMOVAL AND REPLACEMENT (CONTINUED)

FIGURE F.21 – PLUG J52/FILTER CAPACITOR/FIELD RECTIFIER BRIDGE DISCONNECTION

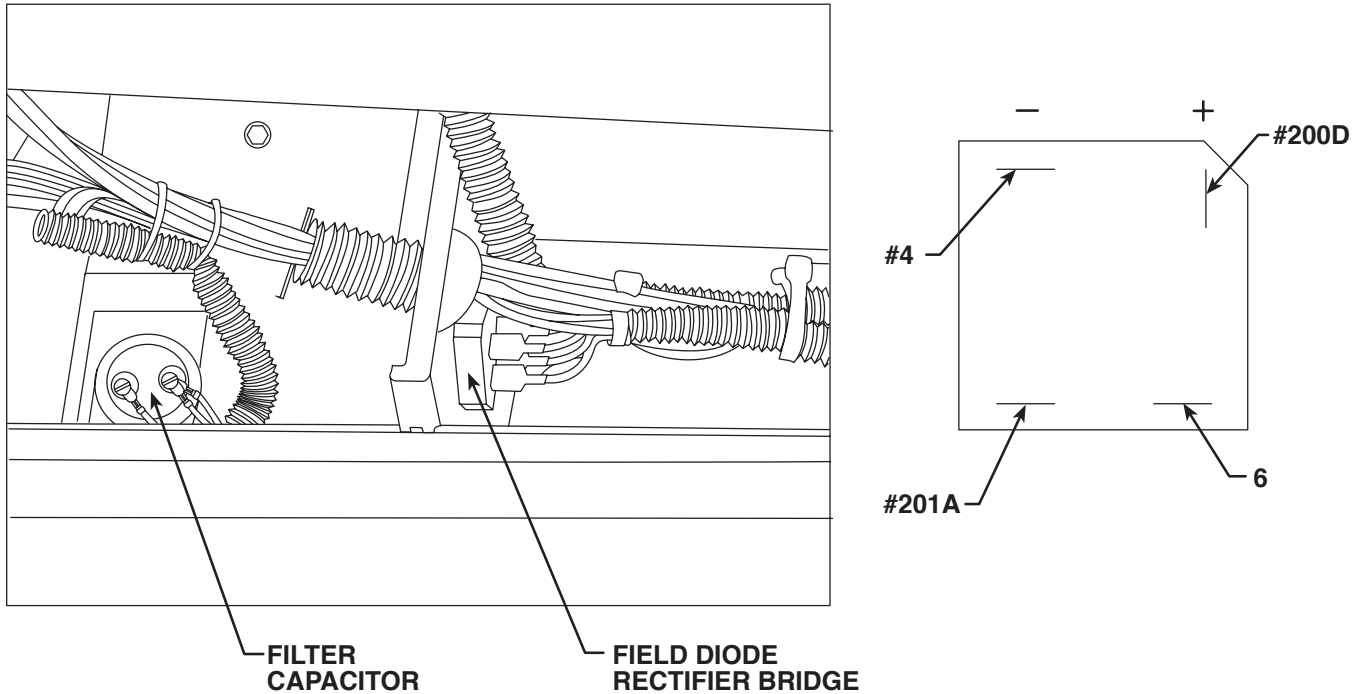

11. See Figure F.21. Using the slot head screw driver, disconnect leads #200A, #200B(+) and #201A(-) or remove screw cap bracket and remove cap from the filter capacitor.
12. Label and remove leads #5H, and #201A, #200A, and #6A from the field diode rectifier bridge.

STATOR/ROTOR REMOVAL AND REPLACEMENT (CONTINUED)

FIGURE F.22 – BRUSH HOLDER AND LEAD REMOVAL

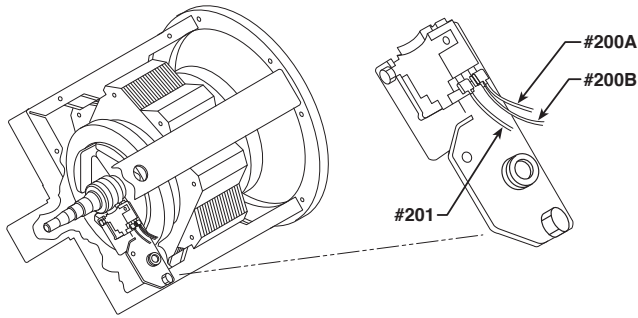

Refer to Figure F.22 for Steps 13-15.

13. Using the 3/8" wrench, remove the brush holder access panel.
14. Using the 3/8" wrench, remove the brush holder assembly.
15. Cut the cable tie and then label and remove brush leads #201(-) and piggy-backed leads #200A(+) and #200B(+) from the brush holder assembly. (The piggy-backed leads connect closest to the stator laminations.)

FIGURE F.23 – CONTROL BOX CONNECTIONS

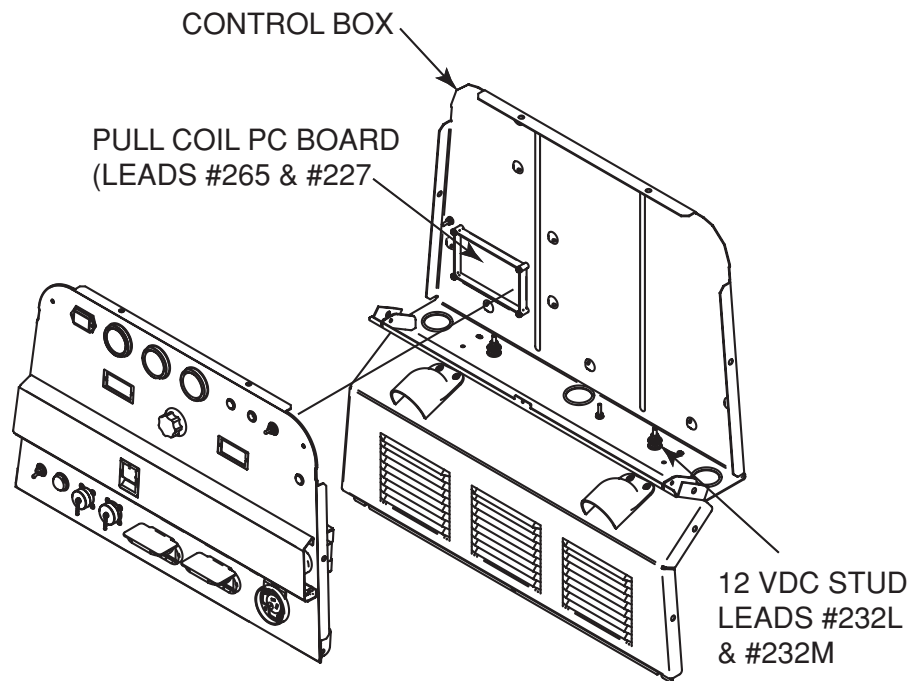

PROCEDURE

1. Turn the engine off.
2. Using the 3/8" wrench, remove the battery cover. Slide the battery out and disconnect the negative battery cable.
3. Unlatch and open the engine service access door. See Figure F.1.
4. Support the door assembly. Using the 3/8" wrench, remove the #10-24 round head screw, lock washer, flat washer, and nut from the top corner of the door hinge assembly, where it attaches to the roof. Remove the support rod.

STATOR/ROTOR REMOVAL AND REPLACEMENT (CONTINUED)

FIGURE F.24 – DOOR REMOVAL

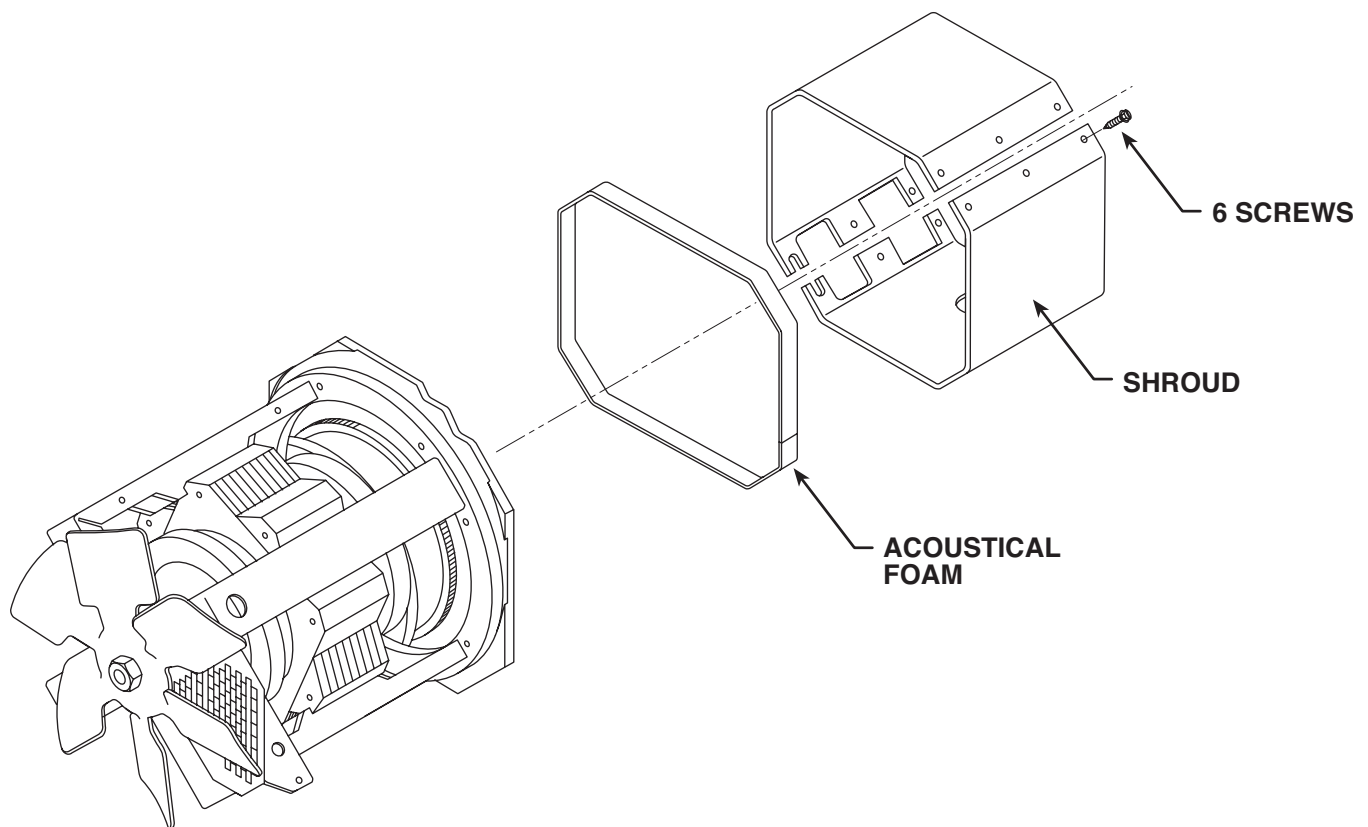

18. See Figure F.24. With the 5/16" wrench, remove the six screws that hold the top and bottom of the alternator shroud together.

19. With the 7/16" wrench, remove the two nuts, lock washers and flat washers that hold the bottom of the shroud to the machine base. Remove the shroud.

STATOR/ROTOR REMOVAL AND REPLACEMENT (CONTINUED)

FIGURE F.25 – LIFT FRAME AND ASSOCIATED COMPONENT REMOVAL

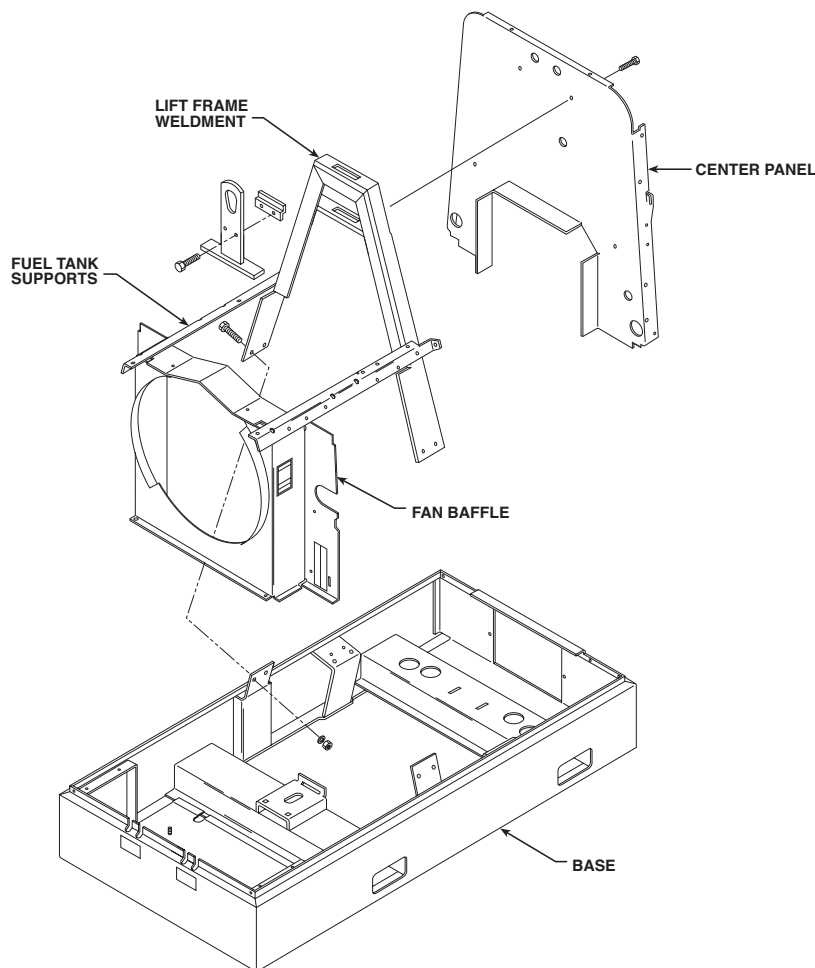

In steps 20 – 24, the lift frame weldment, fuel tank supports, and fan baffle are removed as a unit. See Figure F.25.

20. Using the 3/8" wrench, remove the two bolts (at top) that hold the center panel to the lift frame weldment.

21. Using the 1/2" wrench, remove the two bolts (at bottom) that hold the center panel to the lift frame weldment.

22. With the 3/8" wrench, remove the nuts, lock washers, and flat washers from the two studs that hold the fan baffle to the machine base.

23. Using the 3/4" wrench, remove the four bolts, lock washers, and nuts from the bottom of the lift frame weldment.

24. Carefully remove the lift frame weldment, fuel tank supports, and attached fan baffle. You will need to lift the fan baffle off the two studs on the machine base, then cock it slightly to remove it.

STATOR/ROTOR REMOVAL AND REPLACEMENT (CONTINUED)

FIGURE F.26 – STATOR REMOVAL

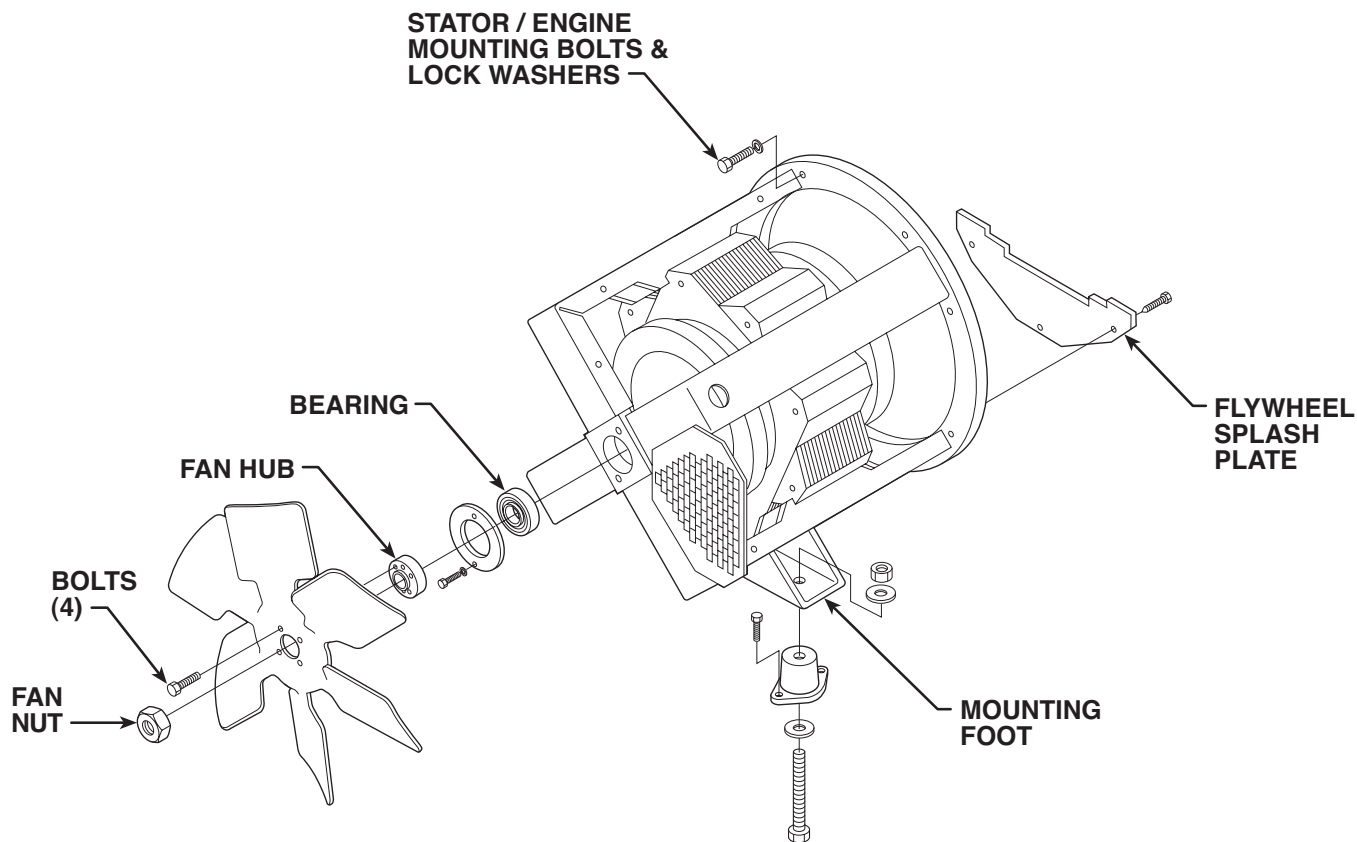

PROCEDURE

First, cut any necessary cable ties in order to free the stator leads from the bundle of leads running to the control box. Refer to Figure F.39 for stator removal.

- Using the 1 1/8" wrench, remove the fan nut. Remove the fan, noting its direction for reassembly.
- Using the gear puller, remove the fan hub.
- Using the 3/8" wrench, remove the two bolts and flat washers holding the bearing in place.
- Using two air impact from bottom wrench on top, remove the nut, lock washer, and carriage bolt holding the alternator mounting foot to the machine base. Do this on each side.
- Using the 3/8" wrench, remove the three bolts from the flywheel splash plate. Remove the plate.
- Support the stator with the hoist. Place wooden blocks under the engine to support it when the stator is removed.
- Using the 17mm" wrench, remove the bolts and lock washers holding the stator to the engine.
- Remove the stator from the engine. It may be necessary to pry and slide it free.

STATOR/ROTOR REMOVAL AND REPLACEMENT (*CONTINUED*)

FIGURE F.27 – ROTOR REMOVAL

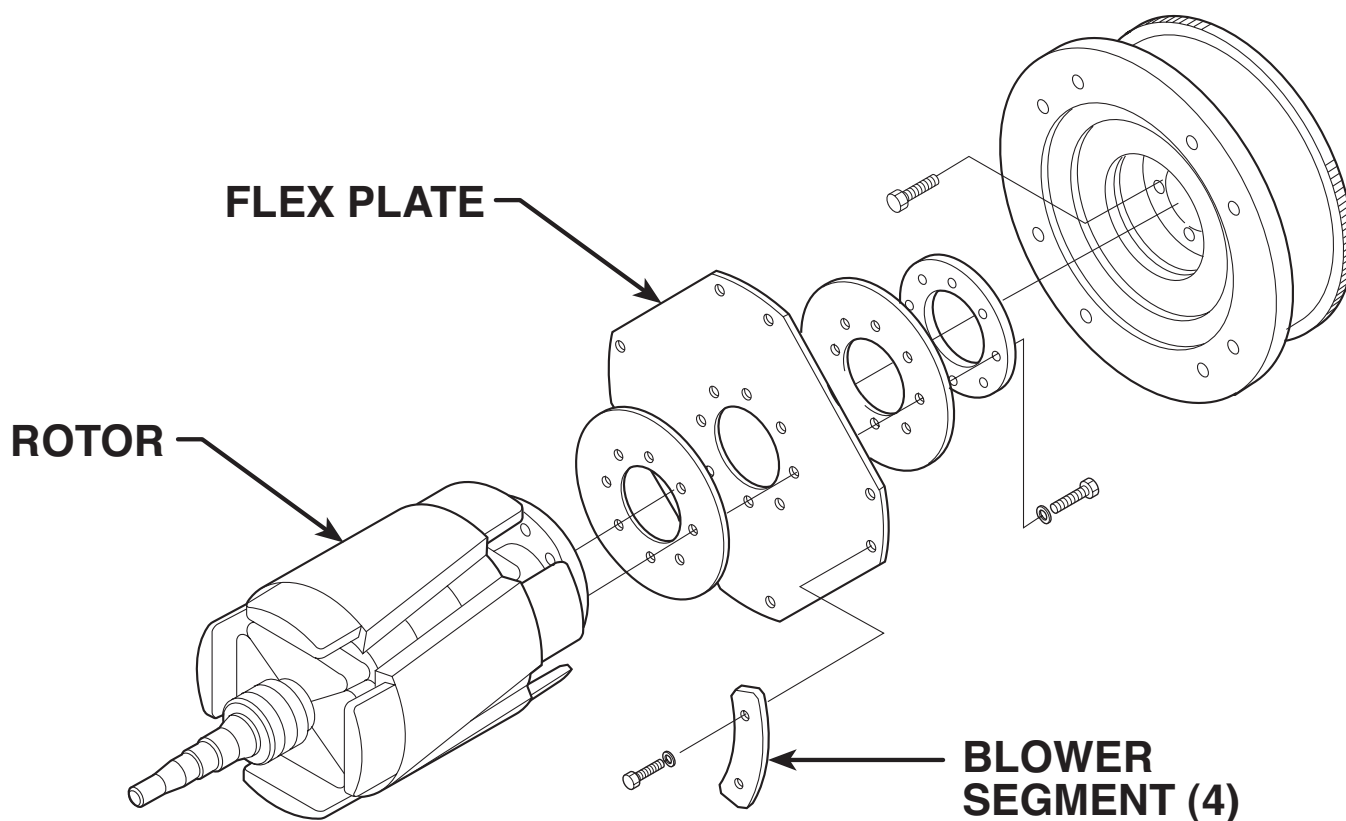
**PROCEDURE**

Refer to Figure F.27 for rotor removal.

1. Support the rotor with the hoist.
2. Using the 5/8" wrench, remove the flex plate bolts, lock washers, and four blower segments.

⚠ WARNING

The rotor will be free to fall when the bolts are removed.

3. Using the hoist, carefully remove the rotor and flex plate assembly.

REASSEMBLY NOTES

Reassemble the rotor and stator to the Vantage 500 by carefully retracing the disassembly procedure steps in reverse order. Keep the following special points in mind as you proceed. Lead Reconnection Checklists are provided here as an aid to reassembly.

INSTALL ROTOR: Support the rotor with the hoist. Install the blower segments and flex plate to the engine flywheel.

INSTALL STATOR: Be sure the engine is blocked securely and the stator is supported with the hoist. Watch bearing housing, install tolerance ring and install bearing cover plate. When stator is bolted to engine inspect ball bearing and make sure it is seated fully in the mount. Using a dead blow hammer or 2X4 and hammer hit the bearing mount to relieve and tension bearing. Install the stator to the engine with the bolts and lock washers. Install the fan blade, making sure that it faces the proper direction, with the fan nut and four cap screws.

Check the air gap for .010" minimum.

Install the brush holder assembly. Be sure the brushes are centered and properly seated on the slip rings.

Install the flywheel splash plate.

STATOR/ROTOR REMOVAL AND REPLACEMENT (CONTINUED)**LEAD RECONNECTION CHECKLIST****ENGINE**

- Leads #5I and #229 to fuel level sensor
- Brush leads #201(-) and #200B(+)
- Leads #5H, and #201A, #200, #200A, and #6A to the field bridge rectifier

OUTPUT PANEL AND CONTROL BOX

- Leads #232N and #227 to Pull Coil PC board
- Leads #232L and #232N to 12 VDC insulated stud
- Leads #200A, #200B(+), and #201(-) and #201A(-) to the field capacitor.

Return to Section TOC

Return to Section TOC

Return to Section TOC

Return to Section TOC

Return to Master TOC

Return to Master TOC

Return to Master TOC

Return to Master TOC

RETEST AFTER REPAIR

Retest a machine:

- If it is rejected under test for any reason that requires you to remove any mechanical part which could affect the machine's electrical characteristics. OR
- If you repair or replace any electrical components.

ENGINE RPM

Mode	No Load RPM	Load RPM
Low Idle	1400 - 1450	NA
High Idle	1890 - 1910	1750 - 1890

WELDER DC (STICK) OUTPUT

Mode Selector Switch	Fine Control	Open Circuit Voltage	Load Volts	Load Amps
30-575 Setting	Maximum	55 - 60	39.5 - 42.0	565 - 585

WELDER CV (WIRE) OUTPUT

Mode Selector Switch	Fine Control	Open Circuit Voltage	Load Volts	Load Amps
CV - Wire	Maximum	55 - 60	39 - 42	520 - 535
CV - Wire	Maximum	NA	48 - 49	20
CV - Wire	Minimum	55 - 60	13 - 14	20

RETEST AFTER REPAIR (*CONTINUED*)

TOUCH START TIG MODE OUTPUT

Mode Selector Switch	Fine Control	Open Circuit Voltage	Short Circuit Current
TIG 20 - 250 A	Maximum	10 - 15	18 - 28
TIG 20 - 250 A	Minimum	10 - 15	18 - 28

AUXILIARY POWER OUTPUT

230 Volt Receptacle			115 Volt Receptacles		
Open Circuit Voltage	Load Volts	Load Amps	Open Circuit Voltage	Load Volts	Load Amps
230 - 264	216 - 252	50	115 - 132	108 - 126	20

Return to Section TOC
Return to Section TOC
Return to Section TOC
Return to Section TOC
Return to Master TOC
Return to Master TOC
Return to Master TOC
Return to Master TOC

VANTAGE® 500



Return to Master TOC

Return to Master TOC

Return to Master TOC

Return to Master TOC

Electrical DiagramsG-1

 Wiring Diagram (G4342 Code 10995 Deutz)G-2

 Wiring Diagram (G4329 Code 10996 Cummins)G-3

 Wiring Diagram (G4847 Codes 11180, 11415,11468, 11931, 11932 &11960 Deutz)G-4

 Wiring Diagram (G4971 Codes 11181 & 11416 Cummins)G-5

 Schematic – Complete Machine (G4363 Code 10995 Deutz)G-6, G-7

 Schematic – Complete Machine (G4442 Code 10996 Cummins)G-8, G-9

 Schematic – Complete Machine (G4848 Codes 11180, 11415,11468, 11931, 11932 & 11960 Deutz) .G-10, G-11

 Schematic – Complete Machine (G4791 Codes 11181 & 1416 Cummins)G-12

 Schematic – Weld Control PC Board* (G4108-1)G-13 thru G-17

 Schematic - Chopper PC Board* (M19792-1)G-18

 Schematic - Peripheral PC Board* (G3663)G-19

 Schematic - Pull Coil / Battery PC Board* (G4117-1)G-20

*** NOTE:** Many PC Board Assemblies are now totally encapsulated, surface mounted and/or multi-layered and are therefore considered to be unserviceable. Assembly drawings of these boards are no longer provided.

Return to Section TOC

Return to Section TOC

Return to Section TOC

Return to Section TOC

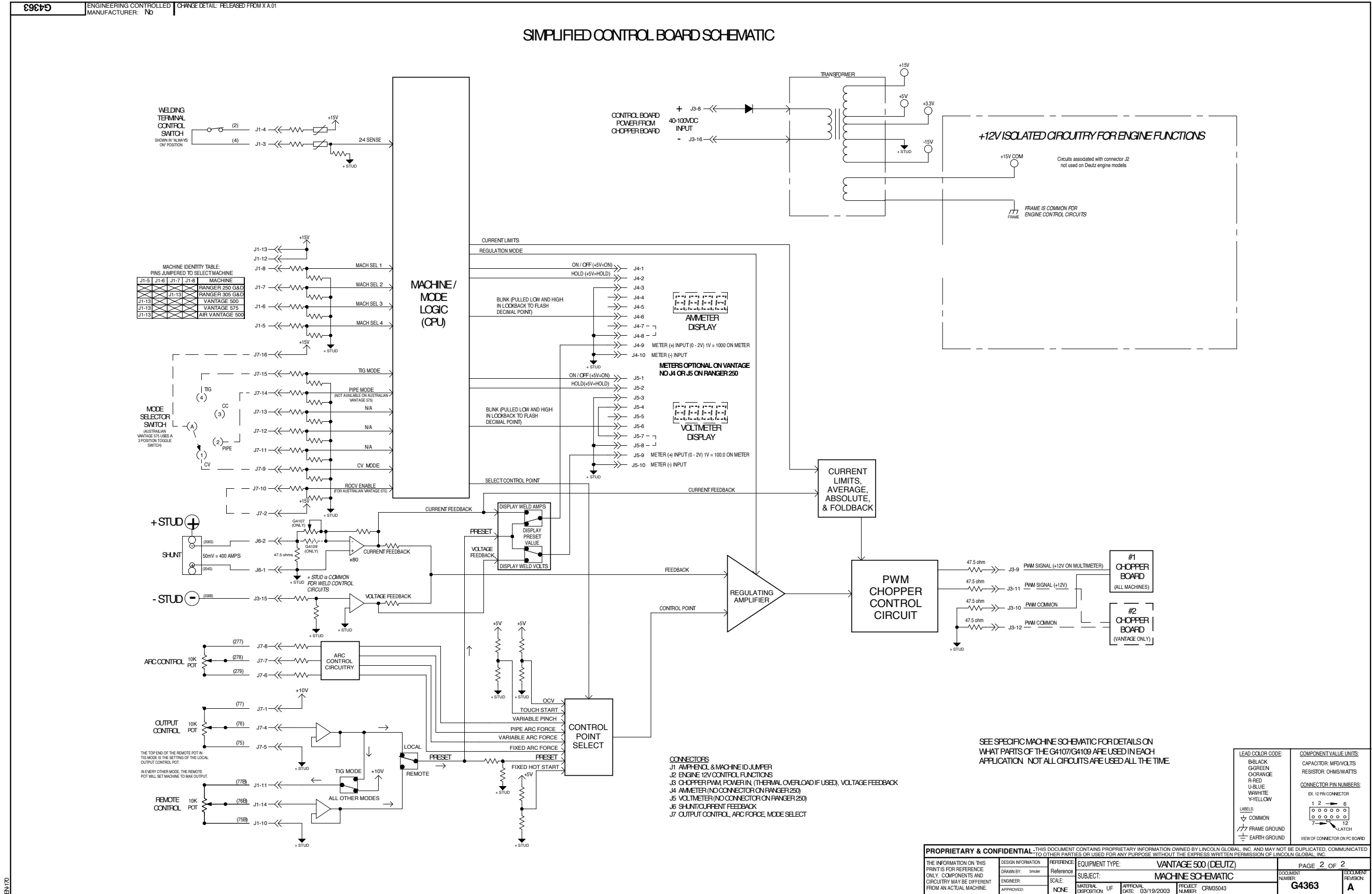

NOTE: This diagram is for reference only. It may not be accurate for all machines covered by this manual.

SCHEMATIC - COMPLETE MACHINE - G4442 (CODE 10996 CUMMINS) PAGE1

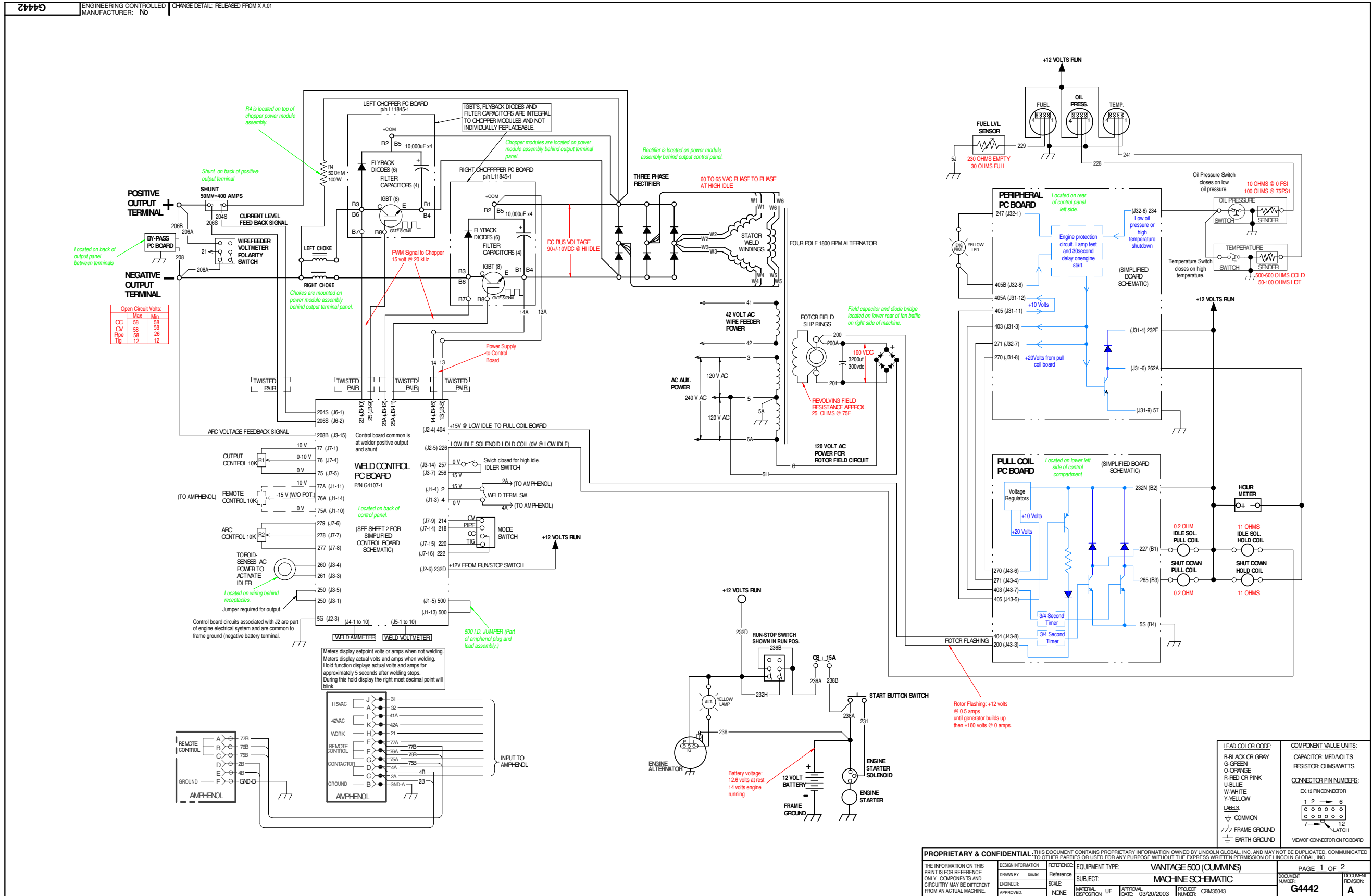

NOTE: This diagram is for reference only. It may not be accurate for all machines covered by this manual.

Return to Section TOC
Return to Master TOC

Return to Section TOC
Return to Master TOC

Return to Section TOC
Return to Master TOC

Return to Section TOC
Return to Master TOC

Return to Section TOC

Return to Section TOC

Return to Section TOC

Return to Section TOC

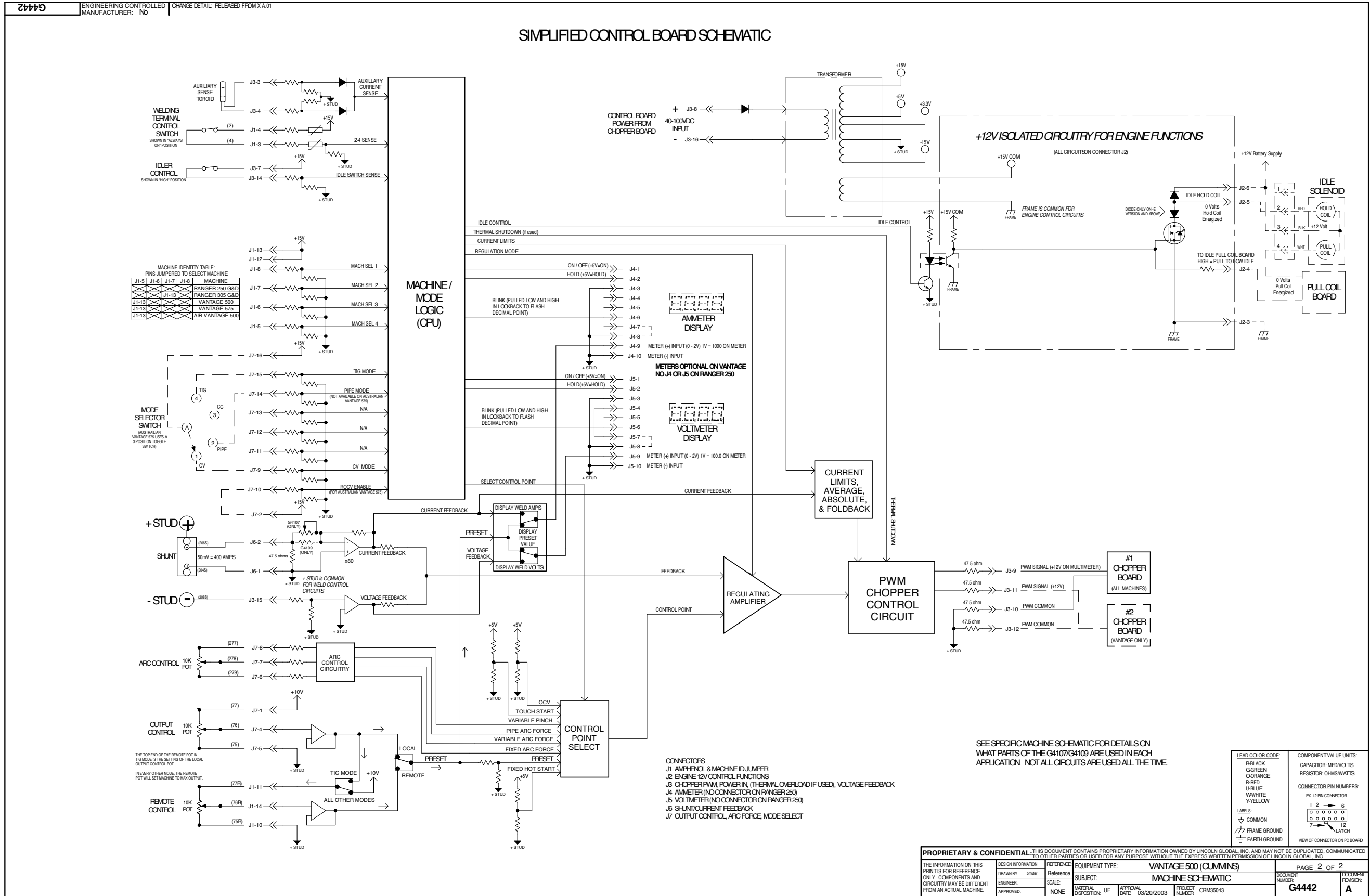

NOTE: This diagram is for reference only. It may not be accurate for all machines covered by this manual.

SCHEMATIC - COMPLETE MACHINE - G4848 (CODES 11180, 11415, 11468, 11931, 11932 & 11960 DEUTZ) PAGE 1

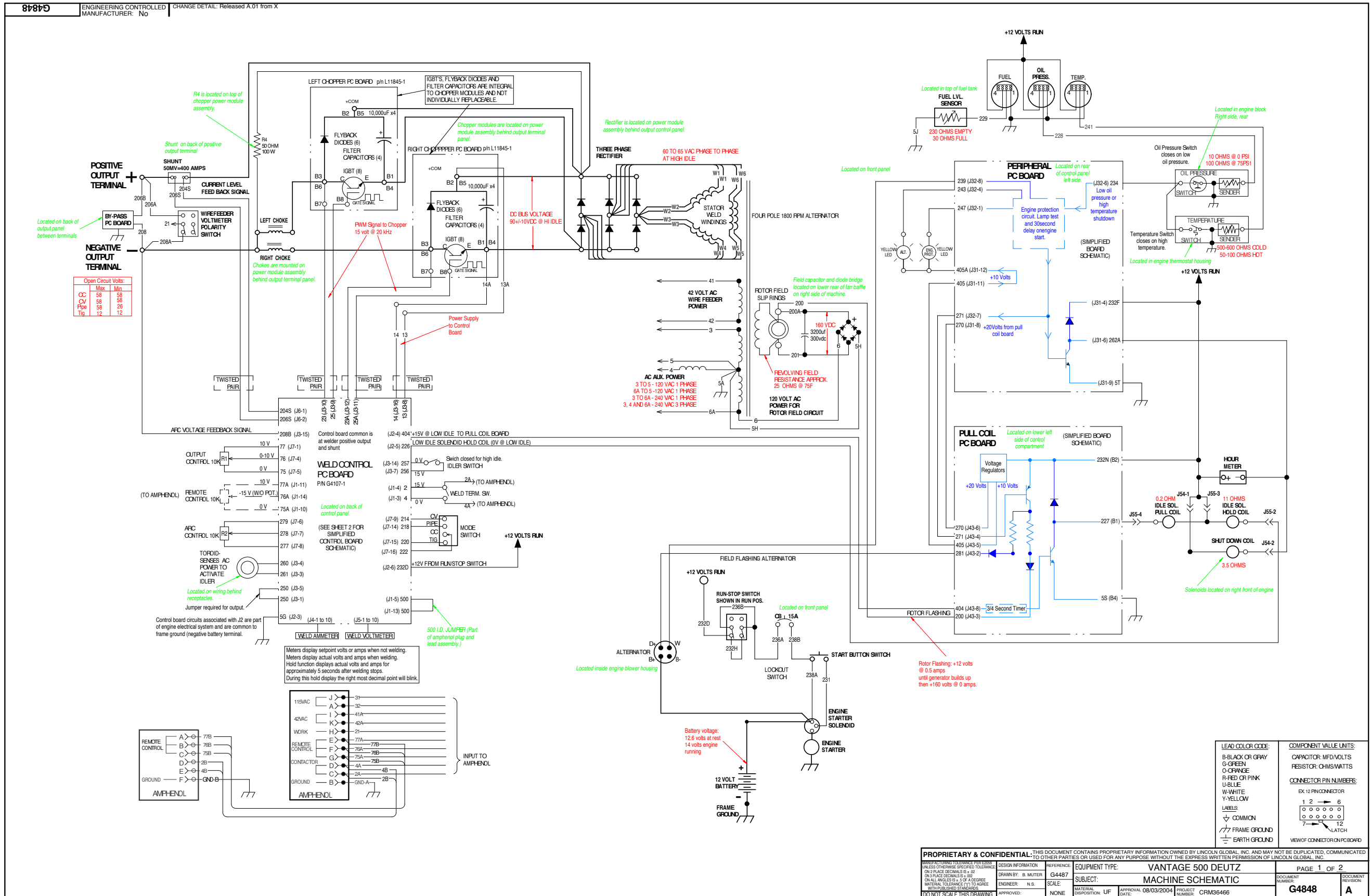

NOTE: This diagram is for reference only. It may not be accurate for all machines covered by this manual.

SCHEMATIC - COMPLETE MACHINE - G4848 (CODES 11180, 11415, 11468, 11931, 11932 & 11960 DEUTZ) PAGE 2

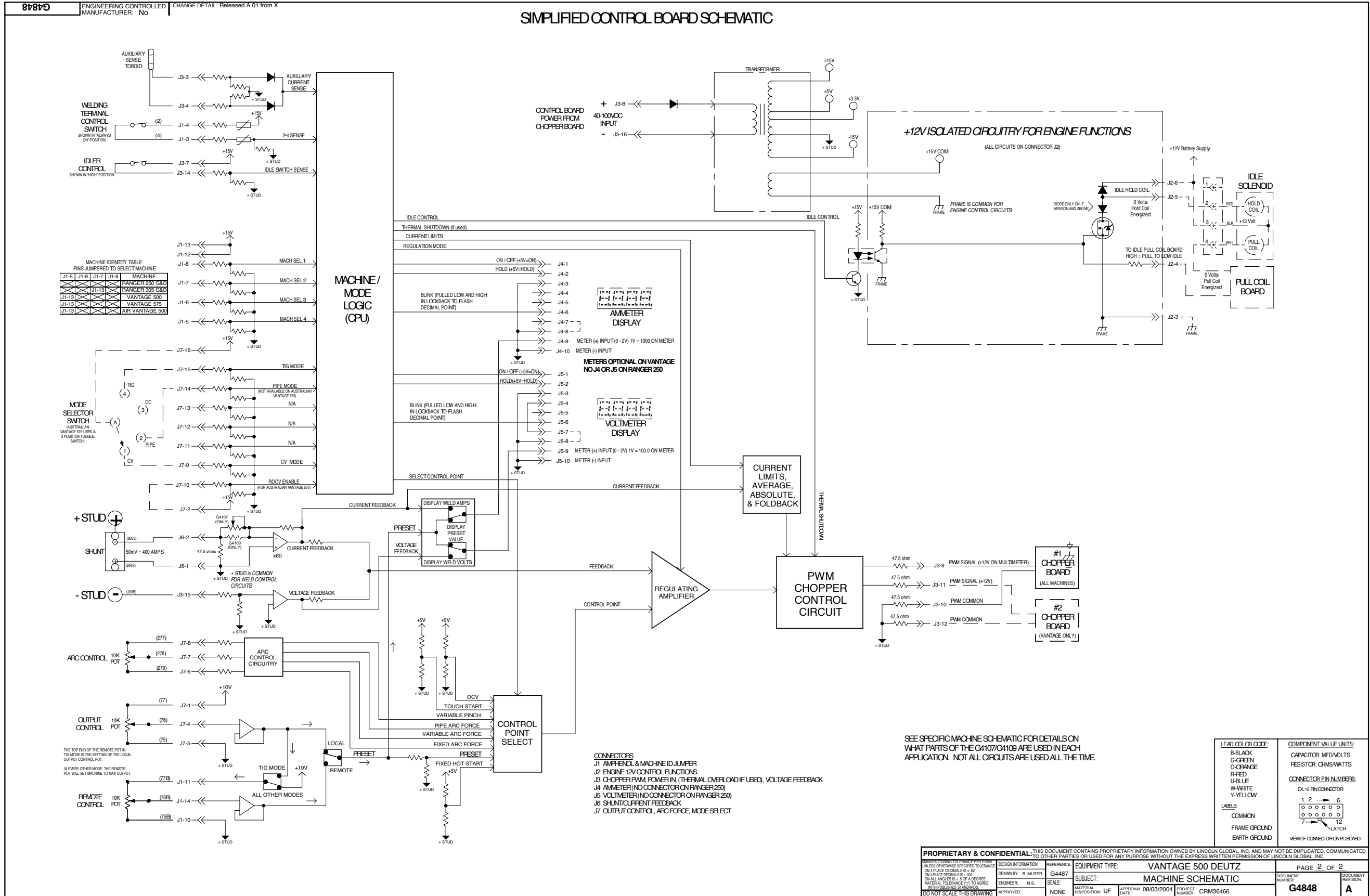

NOTE: This diagram is for reference only. It may not be accurate for all machines covered by this manual.

Return to Section TOC

Return to Section TOC

Return to Section TOC

Return to Section TOC

Return to Master TOC

Return to Master TOC

Return to Master TOC

Return to Master TOC

SCHEMATIC - WELD CONTROL BOARD - G4108 PAGE 1

Return to Section TOC

Return to Section TOC

Return to Section TOC

Return to Section TOC

Return to Master TOC

Return to Master TOC

Return to Master TOC

Return to Master TOC

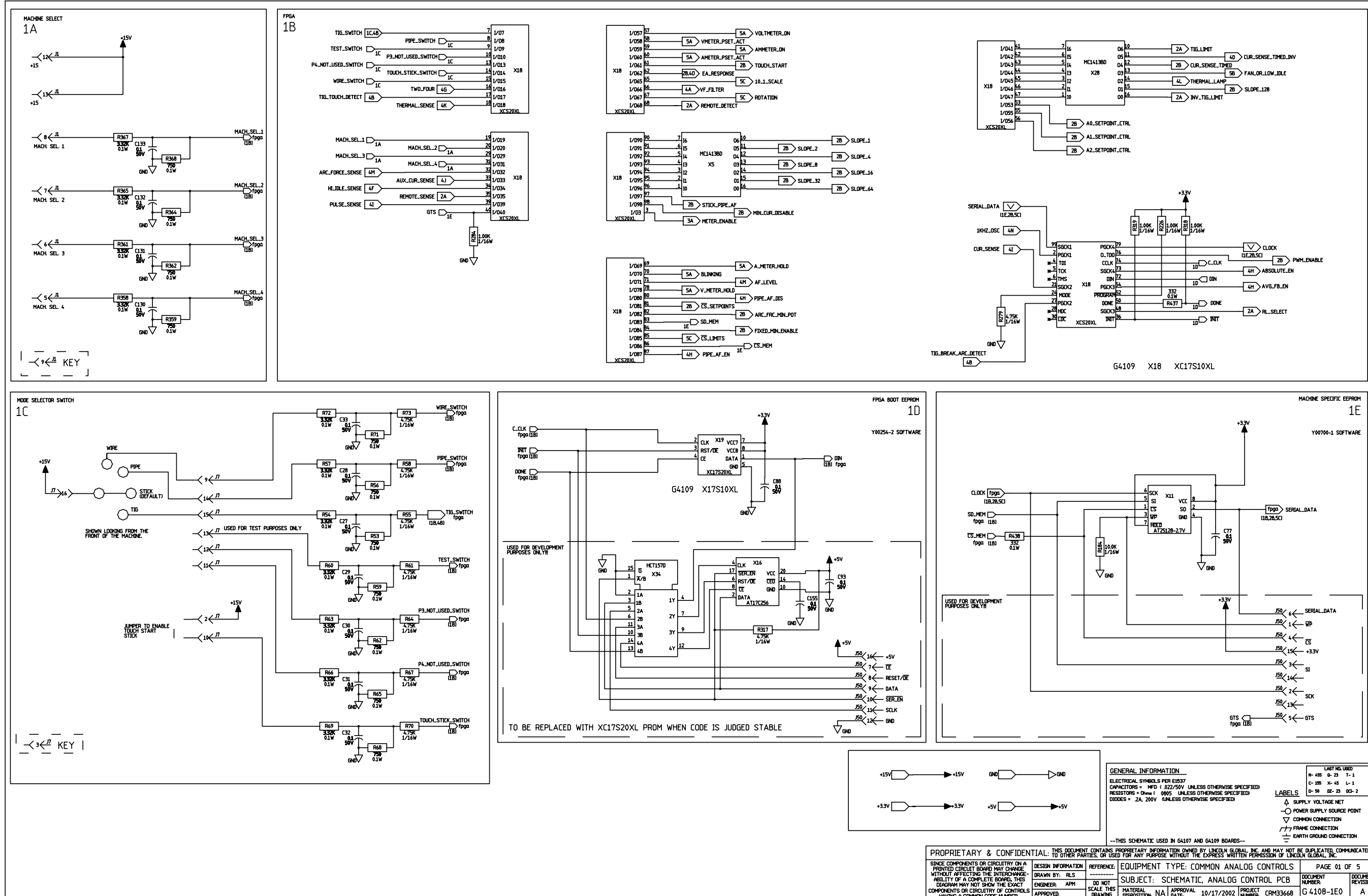

NOTE: This diagram is for reference only. It may not be accurate for all machines covered by this manual.



PROPRIETARY & CONFIDENTIAL: THIS DOCUMENT CONTAINS PROPRIETARY INFORMATION OWNED BY LINCOLN GLOBAL, INC. AND MAY NOT BE DUPLICATED, COMMUNICATED TO OTHER PARTIES, OR USED FOR ANY PURPOSE WITHOUT THE EXPRESS WRITTEN PERMISSION OF LINCOLN GLOBAL, INC.		DESIGN INFORMATION DRAWN BY: RLS ENGINEER: APM APPROVED:		REFERENCE: EQUIPMENT TYPE: COMMON ANALOG CONTROLS SUBJECT: SCHEMATIC, ANALOG CONTROL PCB MATERIAL DISPOSITION: NA APPROVAL DATE: 10/17/2002 PROJECT NUMBER: CRM33668		PAGE 01 OF 5 DOCUMENT NUMBER: G 4108-1E0 REVISION: A	
--	--	--	--	--	--	---	--

GENERAL INFORMATION
 ELECTRICAL SYMBOLS PER E1537
 CAPACITORS = MFD (.022/50V UNLESS OTHERWISE SPECIFIED)
 RESISTORS = OHMS (0005 UNLESS OTHERWISE SPECIFIED)
 DIODES = 2A, 200V UNLESS OTHERWISE SPECIFIED

LAST NO. USED
 R-458 0-23 T-1
 C-135 X-15 L-1
 D-58 BZ-23 OC-2

LEGEND
 Δ SUPPLY VOLTAGE NET
 ○ POWER SUPPLY SOURCE POINT
 ▽ COMMON CONNECTION
 ▽ FRAME CONNECTION
 ⊕ EARTH GROUND CONNECTION

--THIS SCHEMATIC USED IN G4107 AND G4109 BOARDS--

SCHEMATIC - WELD CONTROL BOARD - G4801-1 PAGE 3

Return to Section TOC

Return to Section TOC

Return to Section TOC

Return to Section TOC

Return to Master TOC

Return to Master TOC

Return to Master TOC

Return to Master TOC

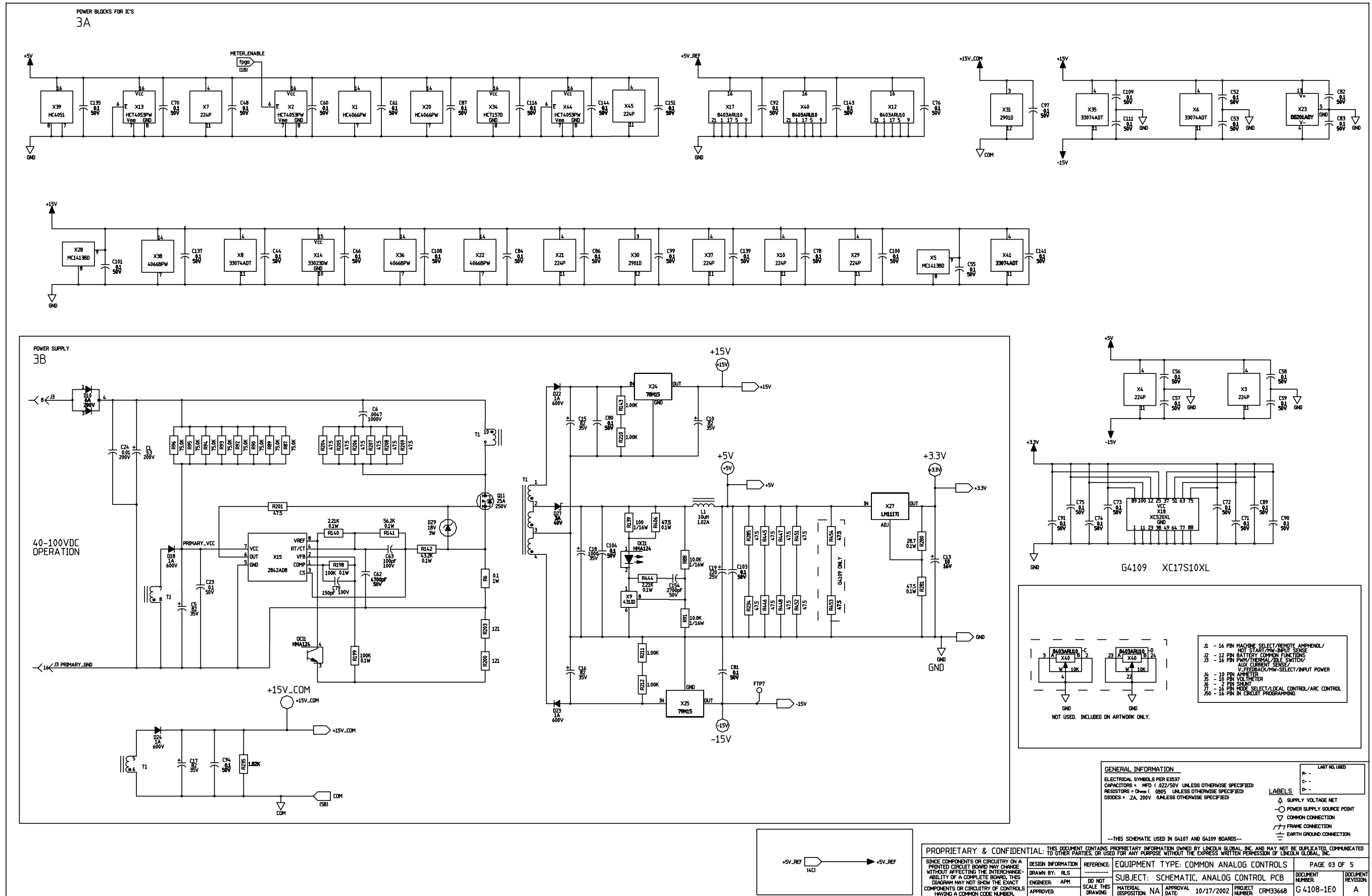

NOTE: This diagram is for reference only. It may not be accurate for all machines covered by this manual.

SCHEMATIC - WELD CONTROL BOARD - G4801-1 PAGE 4

Return to Section TOC

Return to Section TOC

Return to Section TOC

Return to Section TOC

Return to Master TOC

Return to Master TOC

Return to Master TOC

Return to Master TOC

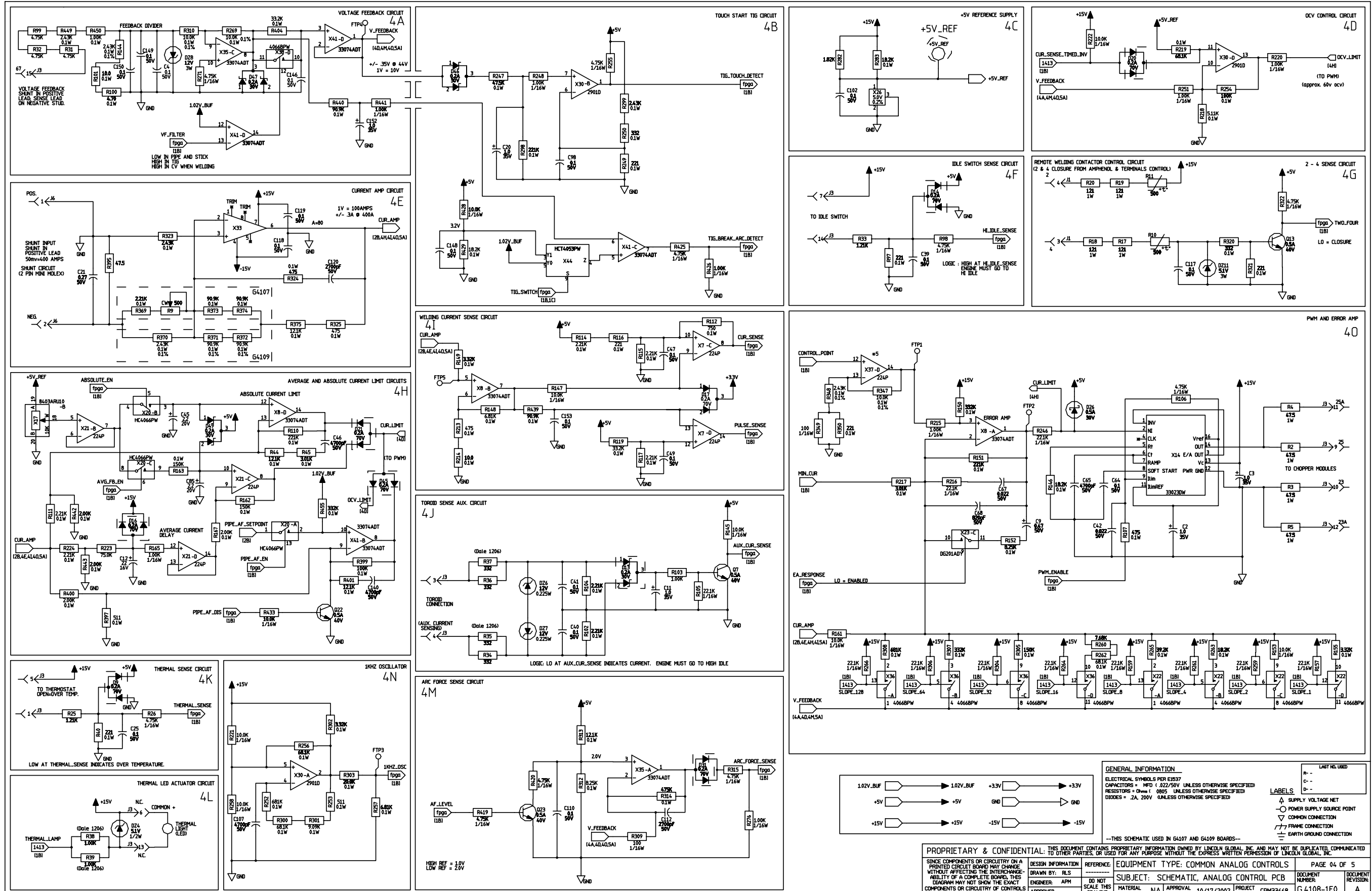

NOTE: This diagram is for reference only. It may not be accurate for all machines covered by this manual.

SCHEMATIC - WELD CONTROL BOARD - PAGE 5

Return to Section TOC
Return to Master TOC

Return to Section TOC
Return to Master TOC

Return to Section TOC
Return to Master TOC

Return to Section TOC
Return to Master TOC

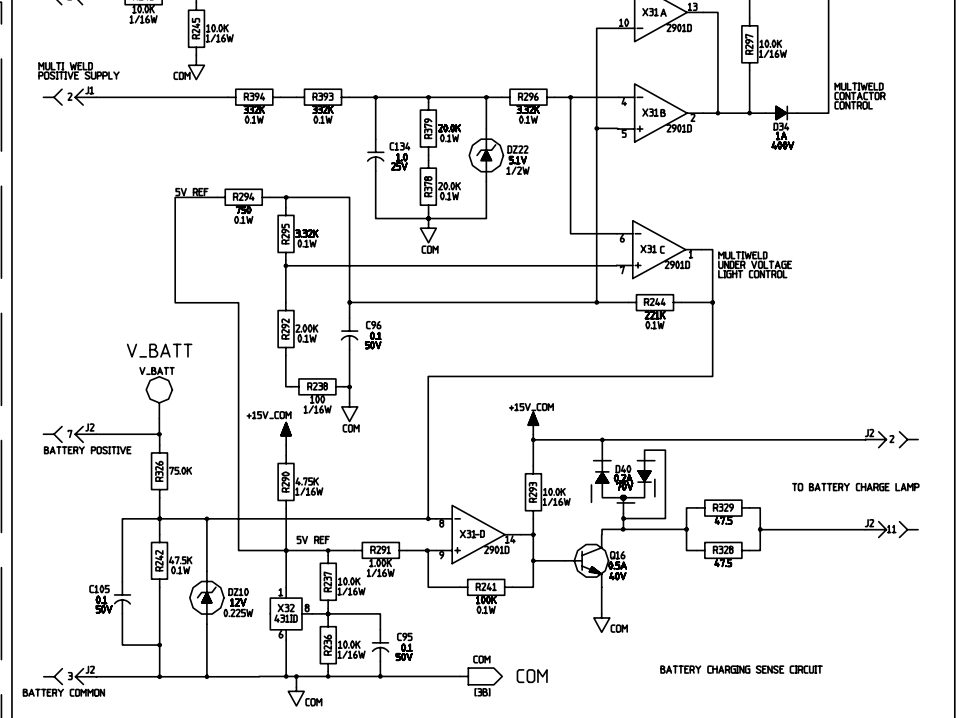
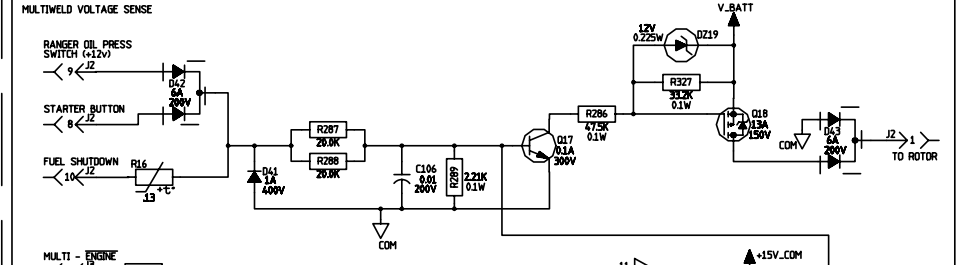
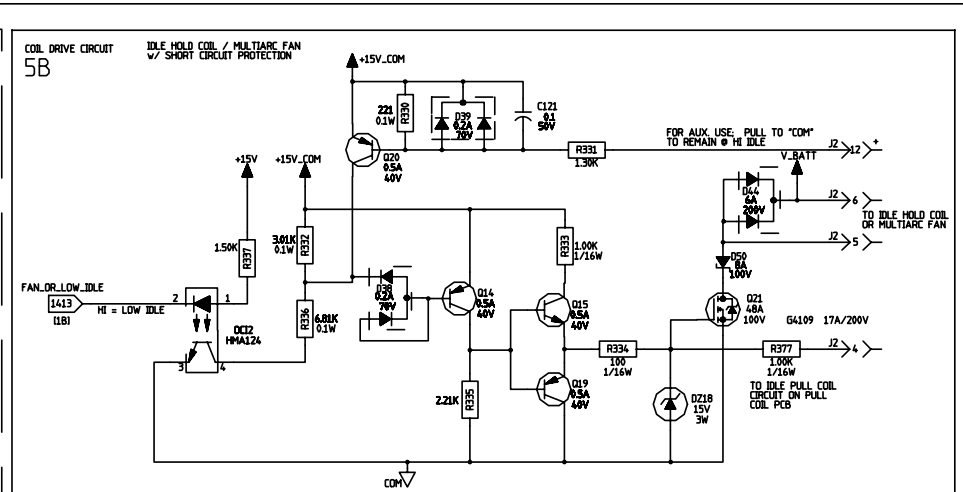
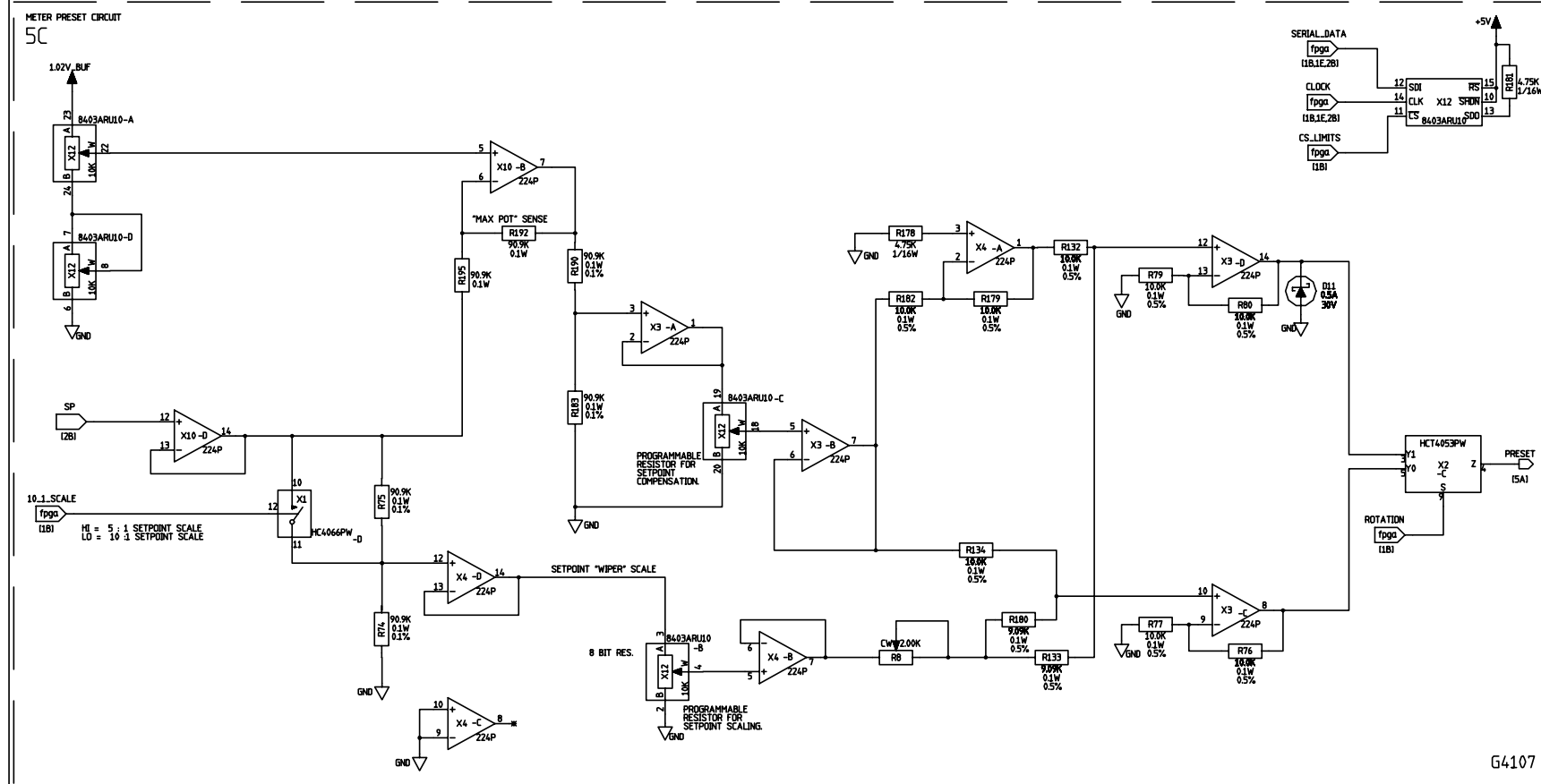
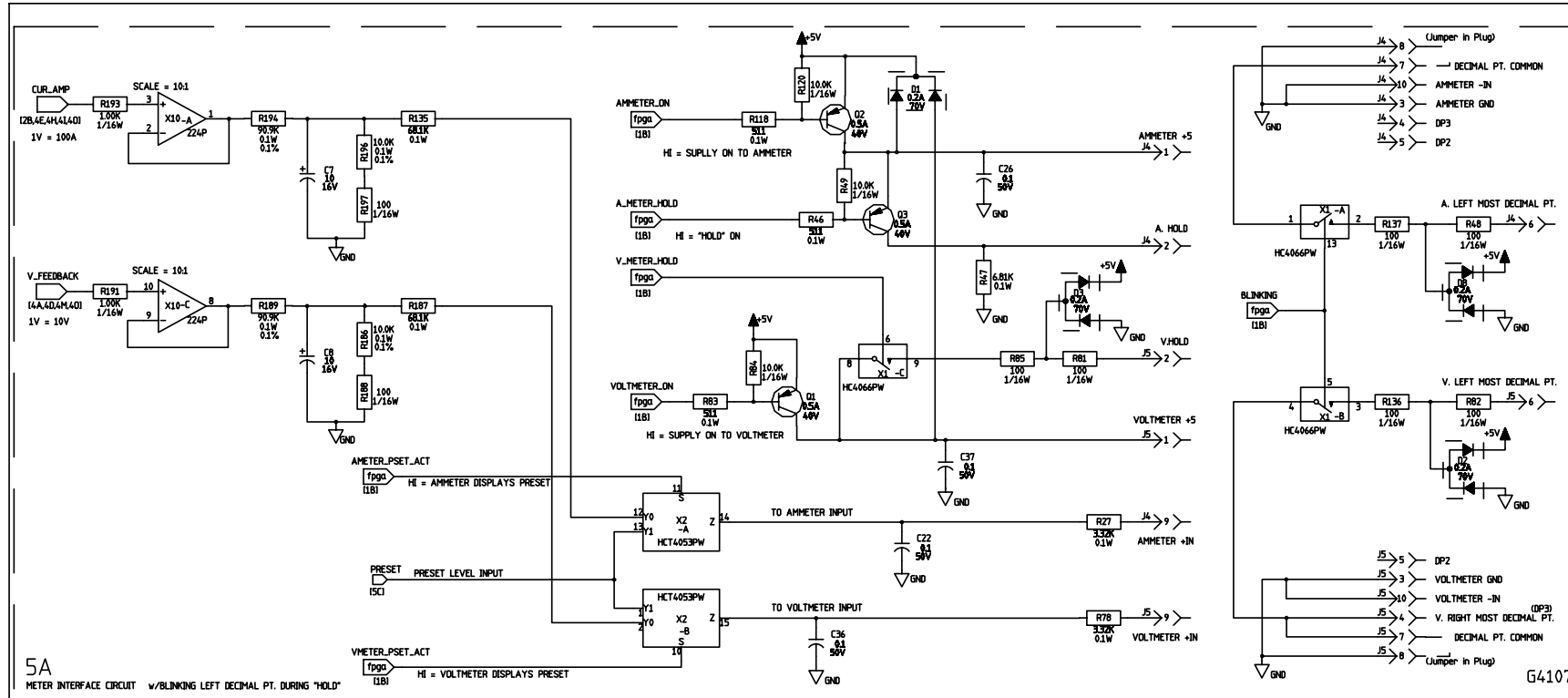

GENERAL INFORMATION

ELECTRICAL SYMBOLS PER E1937
CAPACITORS = MFD (0.22/50V UNLESS OTHERWISE SPECIFIED)
RESISTORS = Ohms (0805 UNLESS OTHERWISE SPECIFIED)
DIODES = 2A, 200V UNLESS OTHERWISE SPECIFIED

LABELS

▲ SUPPLY VOLTAGE NET
○ POWER SUPPLY SOURCE POINT
▽ COMMON CONNECTION
// FRAME CONNECTION
⊥ EARTH GROUND CONNECTION

---THIS SCHEMATIC USED IN G4107 AND G4109 BOARDS---

PROPRIETARY & CONFIDENTIAL: THIS DOCUMENT CONTAINS PROPRIETARY INFORMATION OWNED BY LINCOLN GLOBAL, INC. AND MAY NOT BE DUPLICATED, COMMUNICATED TO OTHER PARTIES, OR USED FOR ANY PURPOSE WITHOUT THE EXPRESS WRITTEN PERMISSION OF LINCOLN GLOBAL, INC.		EQUIPMENT TYPE: COMMON ANALOG CONTROLS		PAGE 05 OF 5	
SINCE COMPONENTS OR CIRCUITRY ON A PRINTED CIRCUIT BOARD MAY CHANGE WITHOUT AFFECTING THE INTERCHANGEABILITY OF A COMPLETE BOARD, THIS DIAGRAM MAY NOT SHOW THE EXACT COMPONENTS OR CIRCUITRY OF CONTROLS HAVING A COMMON CODE NUMBER.		DESIGN INFORMATION DRAWN BY: RLS ENGINEER: APM APPROVED:		REFERENCE: 3D NOT SCALE THIS DRAWING	
		SUBJECT: SCHEMATIC, ANALOG CONTROL PCB		DOCUMENT NUMBER: G4108-1E0	
		MATERIAL DISPOSITION: NA		APPROVAL DATE: 10/17/2002	
		PROJECT NUMBER: CRM33668		REVISION: A	

NOTE: This diagram is for reference only. It may not be accurate for all machines covered by this manual.

SCHEMATIC - PERIPHERAL BOARD - G3663

Return to Section TOC

Return to Section TOC

Return to Section TOC

Return to Section TOC

Return to Master TOC

Return to Master TOC

Return to Master TOC

Return to Master TOC

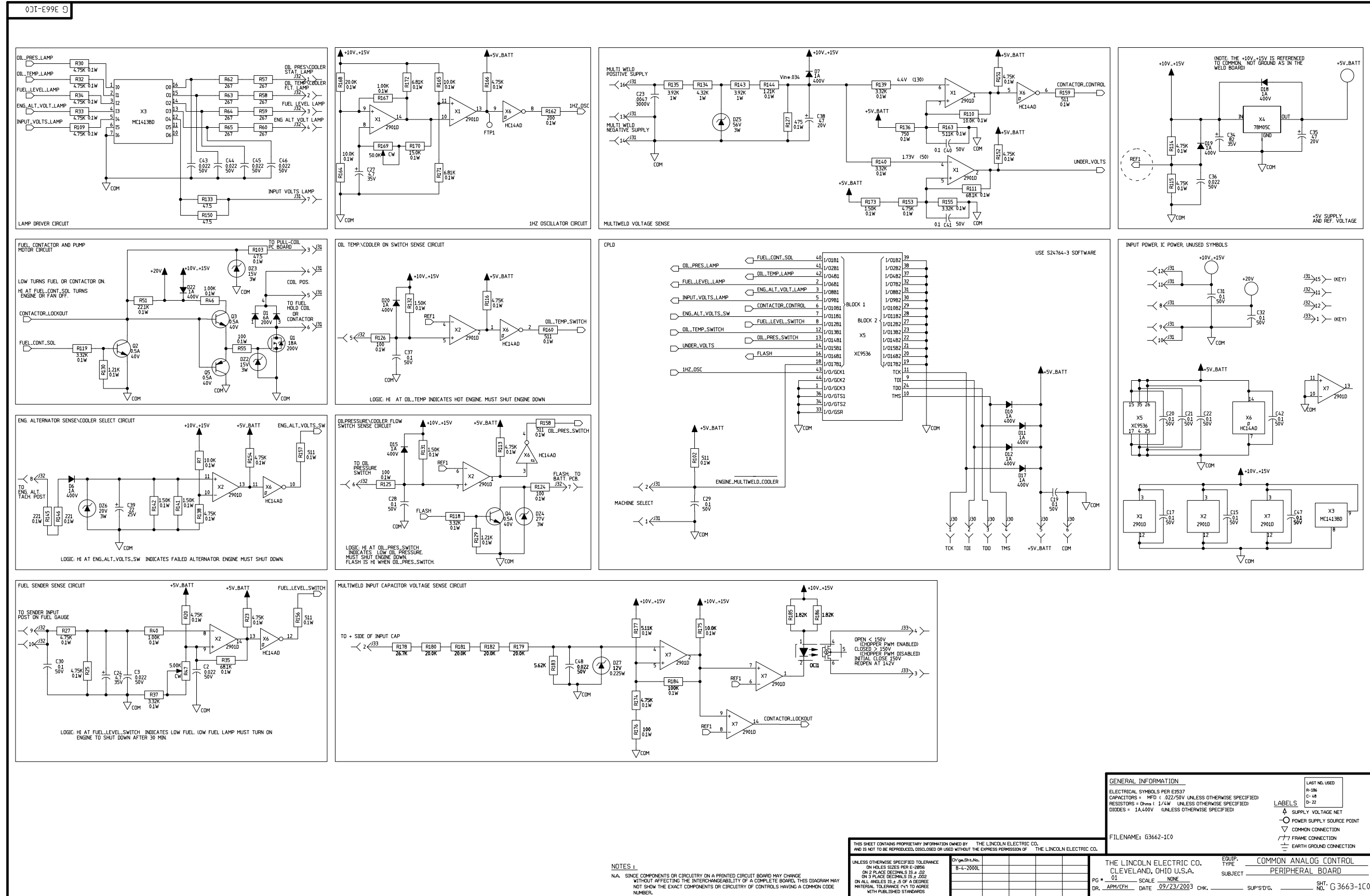

NOTE: This diagram is for reference only. It may not be accurate for all machines covered by this manual.

SCHEMATIC PULL COIL/BATTERY BOARD - G4117-1

Return to Section TOC

Return to Section TOC

Return to Section TOC

Return to Section TOC

Return to Master TOC

Return to Master TOC

Return to Master TOC

Return to Master TOC

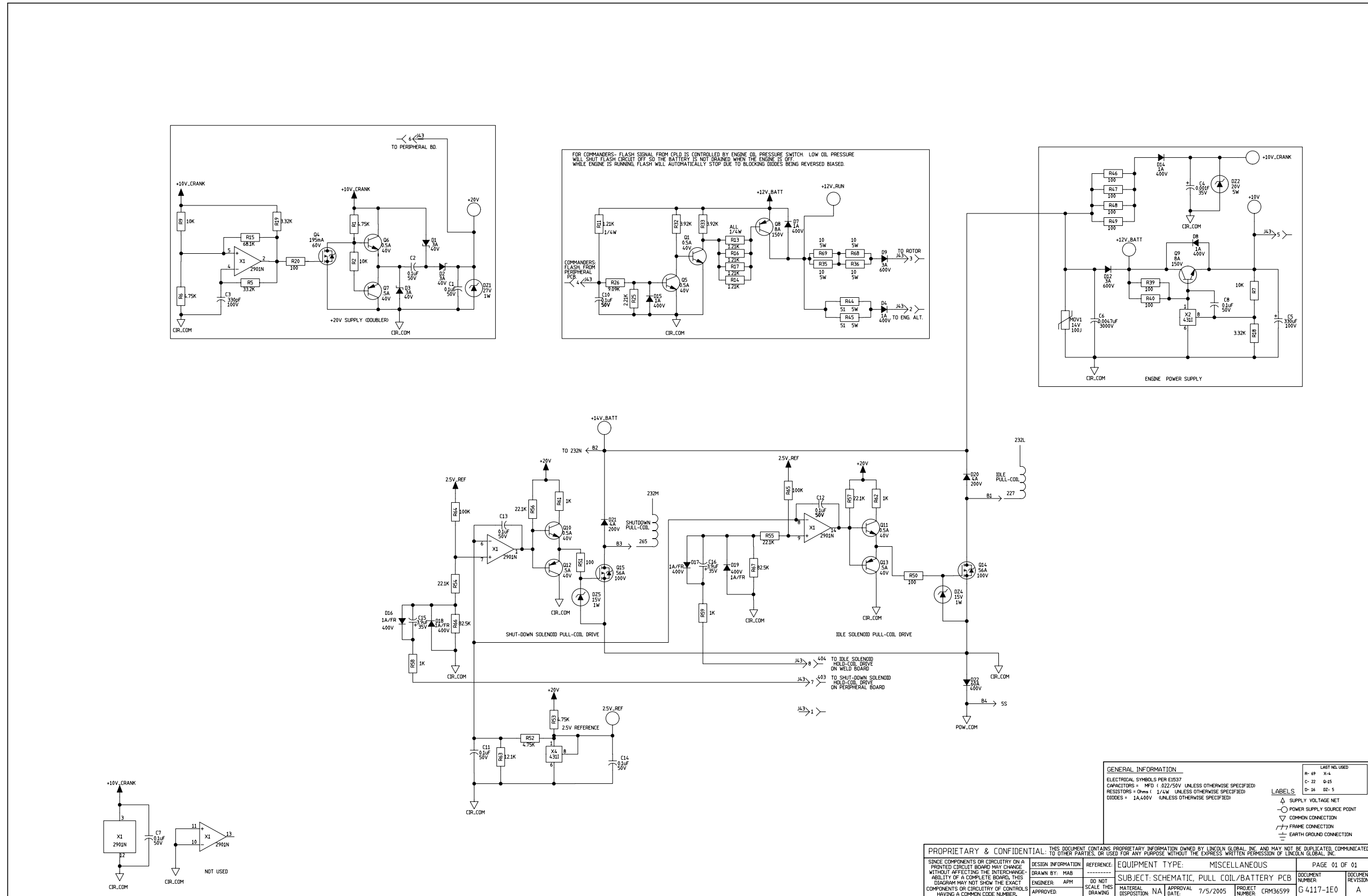

NOTE: This diagram is for reference only. It may not be accurate for all machines covered by this manual.