

## Operator's Manual

# Magnum<sup>®</sup> PRO Barrel HDE 250, 350 & 450

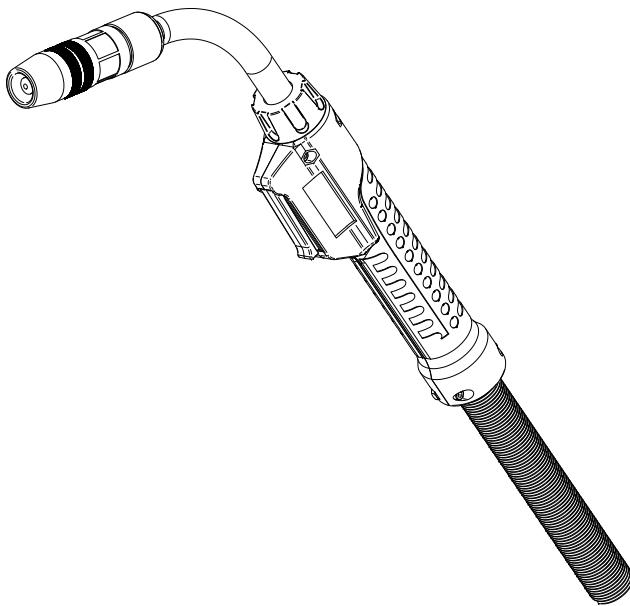

For use with Code Numbers:

**K4856-[ ]**

**K4857-[ ]**

**K4858-[ ]**



**Register your machine:**

[www.lincolnelectric.com/register](http://www.lincolnelectric.com/register)

**Authorized Service and Distributor Locator:**

[www.lincolnelectric.com/locator](http://www.lincolnelectric.com/locator)

**Save for future reference**

Date Purchased

Code: (ex: 10859)

Serial: (ex: U1060512345)

## THANK YOU FOR SELECTING A QUALITY PRODUCT BY LINCOLN ELECTRIC.

### PLEASE EXAMINE CARTON AND EQUIPMENT FOR DAMAGE IMMEDIATELY

When this equipment is shipped, title passes to the purchaser upon receipt by the carrier. Consequently, claims for material damaged in shipment must be made by the purchaser against the transportation company at the time the shipment is received.

### SAFETY DEPENDS ON YOU

Lincoln arc welding and cutting equipment is designed and built with safety in mind. However, your overall safety can be increased by proper installation ... and thoughtful operation on your part. **DO NOT INSTALL, OPERATE OR REPAIR THIS EQUIPMENT WITHOUT READING THIS MANUAL AND THE SAFETY PRECAUTIONS CONTAINED THROUGHOUT.** And, most importantly, think before you act and be careful.

### WARNING

This statement appears where the information must be followed exactly to avoid serious personal injury or loss of life.

### CAUTION

This statement appears where the information must be followed to avoid minor personal injury or damage to this equipment.



### KEEP YOUR HEAD OUT OF THE FUMES.

**DON'T** get too close to the arc. Use corrective lenses if necessary to stay a reasonable distance away from the arc.

**READ** and obey the Safety Data Sheet (SDS) and the warning label that appears on all containers of welding materials.

**USE ENOUGH VENTILATION** or exhaust at the arc, or both, to keep the fumes and gases from your breathing zone and the general area.

**IN A LARGE ROOM OR OUTDOORS**, natural ventilation may be adequate if you keep your head out of the fumes (See below).

**USE NATURAL DRAFTS** or fans to keep the fumes away from your face.

If you develop unusual symptoms, see your supervisor. Perhaps the welding atmosphere and ventilation system should be checked.

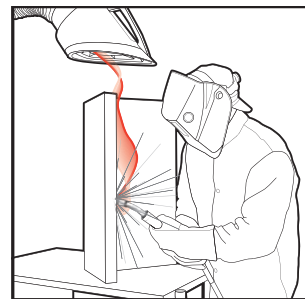

### WEAR CORRECT EYE, EAR & BODY PROTECTION

**PROTECT** your eyes and face with welding helmet properly fitted and with proper grade of filter plate (See ANSI Z49.1).

**PROTECT** your body from welding spatter and arc flash with protective clothing including woolen clothing, flame-proof apron and gloves, leather leggings, and high boots.

**PROTECT** others from splatter, flash, and glare with protective screens or barriers.

**IN SOME AREAS**, protection from noise may be appropriate.

**BE SURE** protective equipment is in good condition.

Also, wear safety glasses in work area **AT ALL TIMES.**



### SPECIAL SITUATIONS

**DO NOT WELD OR CUT** containers or materials which previously had been in contact with hazardous substances unless they are properly cleaned. This is extremely dangerous.

**DO NOT WELD OR CUT** painted or plated parts unless special precautions with ventilation have been taken. They can release highly toxic fumes or gases.

### Additional precautionary measures

**PROTECT** compressed gas cylinders from excessive heat, mechanical shocks, and arcs; fasten cylinders so they cannot fall.

**BE SURE** cylinders are never grounded or part of an electrical circuit.

**REMOVE** all potential fire hazards from welding area.

**ALWAYS HAVE FIRE FIGHTING EQUIPMENT READY FOR IMMEDIATE USE AND KNOW HOW TO USE IT.**



## SECTION A: WARNINGS



### CALIFORNIA PROPOSITION 65 WARNINGS



**WARNING:** Breathing diesel engine exhaust exposes you to chemicals known to the State of California to cause cancer and birth defects, or other reproductive harm.

- Always start and operate the engine in a well-ventilated area.
- If in an exposed area, vent the exhaust to the outside.
- Do not modify or tamper with the exhaust system.
- Do not idle the engine except as necessary.

For more information go to [www.P65warnings.ca.gov/diesel](http://www.P65warnings.ca.gov/diesel)

**WARNING:** This product, when used for welding or cutting, produces fumes or gases which contain chemicals known to the State of California to cause birth defects and, in some cases, cancer. (California Health & Safety Code § 25249.5 *et seq.*)



**WARNING:** Cancer and Reproductive Harm  
[www.P65warnings.ca.gov](http://www.P65warnings.ca.gov)

**ARC WELDING CAN BE HAZARDOUS. PROTECT YOURSELF AND OTHERS FROM POSSIBLE SERIOUS INJURY OR DEATH. KEEP CHILDREN AWAY. PACEMAKER WEARERS SHOULD CONSULT WITH THEIR DOCTOR BEFORE OPERATING.**

Read and understand the following safety highlights. For additional safety information, it is strongly recommended that you purchase a copy of "Safety in Welding & Cutting - ANSI Standard Z49.1" from the American Welding Society, P.O. Box 351040, Miami, Florida 33135 or CSA Standard W117.2. A Free copy of "Arc Welding Safety" booklet E205 is available from the Lincoln Electric Company, 22801 St. Clair Avenue, Cleveland, Ohio 44117-1199.

**BE SURE THAT ALL INSTALLATION, OPERATION, MAINTENANCE AND REPAIR PROCEDURES ARE PERFORMED ONLY BY QUALIFIED INDIVIDUALS.**



### FOR ENGINE POWERED EQUIPMENT.

- Turn the engine off before troubleshooting and maintenance work unless the maintenance work requires it to be running.
- Operate engines in open, well-ventilated areas or vent the engine exhaust fumes outdoors.
- Do not add the fuel near an open flame welding arc or when the engine is running. Stop the engine and allow it to cool before refueling to prevent spilled fuel from vaporizing on contact



with hot engine parts and igniting. Do not spill fuel when filling tank. If fuel is spilled, wipe it up and do not start engine until fumes have been eliminated.

- Keep all equipment safety guards, covers and devices in position and in good repair. Keep hands, hair, clothing and tools away from V-belts, gears, fans and all other moving parts when starting, operating or repairing equipment.
- In some cases it may be necessary to remove safety guards to perform required maintenance. Remove guards only when necessary and replace them when the maintenance requiring their removal is complete. Always use the greatest care when working near moving parts.
- Do not put your hands near the engine fan. Do not attempt to override the governor or idler by pushing on the throttle control rods while the engine is running.
- To prevent accidentally starting gasoline engines while turning the engine or welding generator during maintenance work, disconnect the spark plug wires, distributor cap or magneto wire as appropriate.
- To avoid scalding, do not remove the radiator pressure cap when the engine is hot.



### ELECTRIC AND MAGNETIC FIELDS MAY BE DANGEROUS



- Electric current flowing through any conductor causes localized Electric and Magnetic Fields (EMF). Welding current creates EMF fields around welding cables and welding machines
- EMF fields may interfere with some pacemakers, and welders having a pacemaker should consult their physician before welding.
- Exposure to EMF fields in welding may have other health effects which are now not known.
- All welders should use the following procedures in order to minimize exposure to EMF fields from the welding circuit:
  - Route the electrode and work cables together - Secure them with tape when possible.
  - Never coil the electrode lead around your body.
  - Do not place your body between the electrode and work cables. If the electrode cable is on your right side, the work cable should also be on your right side.
  - Connect the work cable to the workpiece as close as possible to the area being welded.
  - Do not work next to welding power source.



## ELECTRIC SHOCK CAN KILL.



- 3.a. The electrode and work (or ground) circuits are electrically “hot” when the welder is on. Do not touch these “hot” parts with your bare skin or wet clothing. Wear dry, hole-free gloves to insulate hands.
- 3.b. Insulate yourself from work and ground using dry insulation. Make certain the insulation is large enough to cover your full area of physical contact with work and ground.

**In addition to the normal safety precautions, if welding must be performed under electrically hazardous conditions (in damp locations or while wearing wet clothing; on metal structures such as floors, gratings or scaffolds; when in cramped positions such as sitting, kneeling or lying, if there is a high risk of unavoidable or accidental contact with the workpiece or ground) use the following equipment:**

- Semiautomatic DC Constant Voltage (Wire) Welder.
  - DC Manual (Stick) Welder.
  - AC Welder with Reduced Voltage Control.
- 3.c. In semiautomatic or automatic wire welding, the electrode, electrode reel, welding head, nozzle or semiautomatic welding gun are also electrically “hot”.
  - 3.d. Always be sure the work cable makes a good electrical connection with the metal being welded. The connection should be as close as possible to the area being welded.
  - 3.e. Ground the work or metal to be welded to a good electrical (earth) ground.
  - 3.f. Maintain the electrode holder, work clamp, welding cable and welding machine in good, safe operating condition. Replace damaged insulation.
  - 3.g. Never dip the electrode in water for cooling.
  - 3.h. Never simultaneously touch electrically “hot” parts of electrode holders connected to two welders because voltage between the two can be the total of the open circuit voltage of both welders.
  - 3.i. When working above floor level, use a safety belt to protect yourself from a fall should you get a shock.
  - 3.j. Also see Items 6.c. and 8.



## ARC RAYS CAN BURN.



- 4.a. Use a shield with the proper filter and cover plates to protect your eyes from sparks and the rays of the arc when welding or observing open arc welding. Headshield and filter lens should conform to ANSI Z87.1 standards.
- 4.b. Use suitable clothing made from durable flame-resistant material to protect your skin and that of your helpers from the arc rays.
- 4.c. Protect other nearby personnel with suitable, non-flammable screening and/or warn them not to watch the arc nor expose themselves to the arc rays or to hot spatter or metal.



## FUMES AND GASES CAN BE DANGEROUS.



- 5.a. Welding may produce fumes and gases hazardous to health. Avoid breathing these fumes and gases. When welding, keep your head out of the fume. Use enough ventilation and/or exhaust at the arc to keep fumes and gases away from the breathing zone. **When welding hardfacing (see instructions on container or SDS) or on lead or cadmium plated steel and other metals or coatings which produce highly toxic fumes, keep exposure as low as possible and within applicable OSHA PEL and ACGIH TLV limits using local exhaust or mechanical ventilation unless exposure assessments indicate otherwise. In confined spaces or in some circumstances, outdoors, a respirator may also be required. Additional precautions are also required when welding on galvanized steel.**
- 5.b. The operation of welding fume control equipment is affected by various factors including proper use and positioning of the equipment, maintenance of the equipment and the specific welding procedure and application involved. Worker exposure level should be checked upon installation and periodically thereafter to be certain it is within applicable OSHA PEL and ACGIH TLV limits.
- 5.c. Do not weld in locations near chlorinated hydrocarbon vapors coming from degreasing, cleaning or spraying operations. The heat and rays of the arc can react with solvent vapors to form phosgene, a highly toxic gas, and other irritating products.
- 5.d. Shielding gases used for arc welding can displace air and cause injury or death. Always use enough ventilation, especially in confined areas, to insure breathing air is safe.
- 5.e. Read and understand the manufacturer’s instructions for this equipment and the consumables to be used, including the Safety Data Sheet (SDS) and follow your employer’s safety practices. SDS forms are available from your welding distributor or from the manufacturer.
- 5.f. Also see item 1.b.



## WELDING AND CUTTING SPARKS CAN CAUSE FIRE OR EXPLOSION.



- 6.a. Remove fire hazards from the welding area. If this is not possible, cover them to prevent the welding sparks from starting a fire. Remember that welding sparks and hot materials from welding can easily go through small cracks and openings to adjacent areas. Avoid welding near hydraulic lines. Have a fire extinguisher readily available.
- 6.b. Where compressed gases are to be used at the job site, special precautions should be used to prevent hazardous situations. Refer to "Safety in Welding and Cutting" (ANSI Standard Z49.1) and the operating information for the equipment being used.
- 6.c. When not welding, make certain no part of the electrode circuit is touching the work or ground. Accidental contact can cause overheating and create a fire hazard.
- 6.d. Do not heat, cut or weld tanks, drums or containers until the proper steps have been taken to insure that such procedures will not cause flammable or toxic vapors from substances inside. They can cause an explosion even though they have been "cleaned". For information, purchase "Recommended Safe Practices for the Preparation for Welding and Cutting of Containers and Piping That Have Held Hazardous Substances", AWS F4.1 from the American Welding Society (see address above).
- 6.e. Vent hollow castings or containers before heating, cutting or welding. They may explode.
- 6.f. Sparks and spatter are thrown from the welding arc. Wear oil free protective garments such as leather gloves, heavy shirt, cuffless trousers, high shoes and a cap over your hair. Wear ear plugs when welding out of position or in confined places. Always wear safety glasses with side shields when in a welding area.
- 6.g. Connect the work cable to the work as close to the welding area as practical. Work cables connected to the building framework or other locations away from the welding area increase the possibility of the welding current passing through lifting chains, crane cables or other alternate circuits. This can create fire hazards or overheat lifting chains or cables until they fail.
- 6.h. Also see item 1.c.
- 6.i. Read and follow NFPA 51B "Standard for Fire Prevention During Welding, Cutting and Other Hot Work", available from NFPA, 1 Batterymarch Park, PO box 9101, Quincy, MA 022690-9101.
- 6.j. Do not use a welding power source for pipe thawing.



## CYLINDER MAY EXPLODE IF DAMAGED.



- 7.a. Use only compressed gas cylinders containing the correct shielding gas for the process used and properly operating regulators designed for the gas and pressure used. All hoses, fittings, etc. should be suitable for the application and maintained in good condition.
- 7.b. Always keep cylinders in an upright position securely chained to an undercarriage or fixed support.
- 7.c. Cylinders should be located:
  - Away from areas where they may be struck or subjected to physical damage.
  - A safe distance from arc welding or cutting operations and any other source of heat, sparks, or flame.
- 7.d. Never allow the electrode, electrode holder or any other electrically "hot" parts to touch a cylinder.
- 7.e. Keep your head and face away from the cylinder valve outlet when opening the cylinder valve.
- 7.f. Valve protection caps should always be in place and hand tight except when the cylinder is in use or connected for use.
- 7.g. Read and follow the instructions on compressed gas cylinders, associated equipment, and CGA publication P-1, "Precautions for Safe Handling of Compressed Gases in Cylinders," available from the Compressed Gas Association, 14501 George Carter Way Chantilly, VA 20151.



## FOR ELECTRICALLY POWERED EQUIPMENT.



- 8.a. Turn off input power using the disconnect switch at the fuse box before working on the equipment.
- 8.b. Install equipment in accordance with the U.S. National Electrical Code, all local codes and the manufacturer's recommendations.
- 8.c. Ground the equipment in accordance with the U.S. National Electrical Code and the manufacturer's recommendations.

**Refer to**  
**<http://www.lincolnelectric.com/safety>**  
**for additional safety information.**

<b>INSTALLATION .....</b>	<b>SECTION A</b>
GENERAL DESCRIPTION .....	A-1
TECHNICAL SPECIFICATIONS.....	A-2
WHATS INCLUDED .....	A-3
CONNECTOR KIT INSTALLATION TO GUN CABLE.....	A-4
K466-1 AND K466-8 INSTALLATION (FOR LINCOLN FEEDERS).....	A-4
K466-2 INSTALLATION (FOR TWECO ADAPTED FEEDERS).....	A-4
K466-3 INSTALLATION (FOR MILLER FEEDERS).....	A-4
K466-6 AND K466-10 INSTALLATION (WIREMATIC AND LINCOLN 10 SERIES FEEDERS).....	A-4
K613-1 INSTALLATION .....	A-4
K613-3 INSTALLATION .....	A-4
K613-2, K613-7 INSTALLATION.....	A-4
K613-6 INSTALLATION .....	A-4
LINER INSTALLATION AND TRIMMING INSTRUCTIONS.....	A-5
ROTATING THE GUN TUBE.....	A-5
CONTACT TIP AND GAS NOZZLE INSTALLATION.....	A-5
CONNECTION TO FEEDER.....	A-5
CONNECTION TO LINCOLN FEEDERS.....	A-5
CONNECTION TO TWECO ADAPTED FEEDERS.....	A-5
CONNECTION TO MILLER FEEDERS.....	A-6
CONNECTION TO POWERMIG SERIES, POWER WAVE.....	A-6
CONNECTION TO LINCOLN 10 SERIES FEEDERS.....	A-6
<b>OPERATION .....</b>	<b>SECTION B</b>
ELECTRODES AND EQUIPMENT.....	B-1
MAKING A WELD.....	B-1
AVOIDING WIRE FEEDING PROBLEMS .....	B-1
<b>ACCESSORIES .....</b>	<b>SECTION C</b>
<b>MAINTENANCE .....</b>	<b>SECTION D</b>
REMOVAL, INSTALLATION AND TRIMMING GUNLINERS .....	D-1
GUN TUBES AND NOZZLES .....	D-1
GUN CABLES .....	D-1
CABLE REPAIR.....	D-1
GUN TUBE END REPAIR .....	D-1
WIRE FEEDER END REPAIR .....	D-3
WIRE FEEDER END REPAIR .....	D-4
<b>TROUBLESHOOTING.....</b>	<b>SECTION E</b>
<b>PARTS LIST .....</b>	<b>PARTS.LINCOLNELECTRIC.COM</b>
CONTENT/DETAILS MAY BE CHANGED OR UPDATED WITHOUT NOTICE. FOR MOST CURRENT INSTRUCTION MANUALS, GO TO PARTS.LINCOLNELECTRIC.COM.	

**GENERAL DESCRIPTION**

The MAGNUM® PRO BARREL HDE 250, 350 & 450 Amps guns and cable assemblies have been designed to meet IEC 60974-7 specification for welding with steel electrode using the GMAW (gas metal arc welding) and gas-shielded FCAW (flux-cored arc welding) processes. The MAGNUM® PRO BARREL HDE guns are manually guided and air cooled.

MAGNUM® PRO BARREL HDE 250, 350 & 450 guns are not factory equipped with a feeder end connector.

The Magnum PRO Barrel HDE guns can be connected to the following feeders by using the connectors outlined in the table below.

For best Results when welding mild and steels, it is recommended that L-50 or L-56 Lincoln solid wire electrodes be used for the GMAW process and OS70 or OS71 Lincoln UltraCore® or Outershield® electrodes

**⚠ WARNING**

Do not touch electrically live parts such as output terminals or internal wiring



**TABLE A.1 - GUN CONNECTOR KITS**

<b>Manufacturer</b>	<b>Wire Feeder Model</b>	<b>K466 Connector Kits (accept K44-series liners)</b>	<b>K613 Connector Kits (accept K45-series liners)</b>
Lincoln Electric®	LN-7 Series, LN-8, LN-9, LN-25 (Up to .052 in./1.4 mm wire, LN-23P	K466-1	K613-1
	LN-8, LN-9 Series, LN-25 (1/16 in./1.6 mm and larger), LN-23P	K466-8	K613-6
	LF-72, LF-74 Series, Flex Feed 74 HT, Flex Feed 84, LN-25 PRO, LN-25X, Activ8, Activ8x	K466-10	K613-7
	Power Feed™ 10, 10M, 25M, and 84	K466-10	K613-7
	POWER MIG® Series and Power Wave® C300	K466-6	N/A
Tweco® Adapted	No. 2, No. 3, No. 4 Guns	K466-2	K613-2
Miller®	Intellimatic, Sidekick, D-51A, Porto-Mig Millermatic 130, 200, MM-35, S-42GL, S-52A, Swing Arc-Dual, Swing Arc-Single, S- 32S, 52D, 54D, 54E, 60 Series	K466-3	K613-3

**TECHNICAL SPECIFICATIONS**

<b>MAGNUM® PRO BARREL HDE 250 &amp; 350 GUNS</b>									
<b>K4856-□ 100% DUTY CYCLE AT 250 AMPS WITH CO2 &amp; MIXED GAS</b>									
<b>K4857-□ 100% DUTY CYCLE AT 350 AMPS WITH CO2 &amp; MIXED GAS</b>									
Description Product Number	Gun Cable Length (m)	Wire size In (mm)	Contact Tips Standard Duty	Gas Diffuser Assembly	Gas Nozzle	Insulator	Cable Liner	Gun Tube 60°	Gun Tube 45°
K4856-1	10 ft (3.0)	.035-5/64 in (0.9-2.0 mm)	KP2744-035	KP2746-1	KP2742-1-62R	KP2773-2	KP42-3035-15	KP4693-60	KP4693-45
K4856-2	15 ft (4.5)	.035-5/64 in (0.9-2.0 mm)							
K4856-3	20 ft (6.1)	.035-5/64 in (0.9-2.0 mm)							
K4856-4	25 ft (7.6)	.035-5/64 in (0.9-2.0 mm)							
K4857-1	10 ft (3.0)	.035-5/64 in (0.9-2.0 mm)	KP2745-045	KP2747-1	KP2743-1-62R	KP2773-1	KP44-3545-15	KP4694-60	KP4694-45
K4857-2	15 ft (4.5)	.035-5/64 in (0.9-2.0 mm)							
K4857-3	20 ft (6.1)	.035-5/64 in (0.9-2.0 mm)							
K4857-4	25 ft (7.6)	.035-5/64 in (0.9-2.0 mm)							

<b>MAGNUM® PRO CURVE HDE 450 GUNS</b>									
<b>K4858-□ 100% DUTY CYCLE AT 450 AMPS WITH CO2 &amp; MIXED GAS</b>									
Description Product Number	Gun Cable Length (m)	Wire size In (mm)	Contact Tips Standard Duty	Gas Diffuser Assembly	Gas Nozzle	Insulator	Cable Liner	Gun Tube 60°	Gun Tube 45°
K4858-1	10 ft (3.0)	.035-5/64 in (0.9-2.0 mm)	KP2744-045	KP2747-1	KP2743-1-62R	KP2773-1	KP44-3545-15	KP4695-60	KP4695-45
K4858-2	15 ft (4.5)	.035-5/64 in (0.9-2.0 mm)							
K4858-3	20 ft (6.1)	.035-5/64 in (0.9-2.0 mm)							
K4858-4	25 ft (7.6)	.035-5/64 in (0.9-2.0 mm)							



<b>MAGNUM® PRO BARREL HDE READY PAK 250 , 350 &amp; 450 GUNS</b> <b>K4856-□ 100% DUTY CYCLE AT 250 AMPS WITH CO2 &amp; MIXED GAS</b> <b>K4857-□ 100% DUTY CYCLE AT 350 AMPS WITH CO2 &amp; MIXED GAS</b> <b>K4858-□ 100% DUTY CYCLE AT 450 AMPS WITH CO2 &amp; MIXED GAS</b>								
Description	Gun Cable Length	Wire size In	Contact Tips	Gas				Gun Tube
Product Number	(m)	(mm)	Standard Duty	Diffuser Assembly	Gas Nozzle	Insulator	Cable Liner	60°
K4856-2-1-45	15 ft (4.5)	.035-5/64 in	KP2744-045	KP2746-1	KP2742-1-62R	KP2773-2	KP42-4045-15	KP4693-60
K4856-2-10-45	15 ft (4.5)	.035-5/64 in (0.9-2.0 mm)						
K4856-2-3-45	15 ft (4.5)	.035-5/64 in (0.9-2.0 mm)						
K4857-2-1-116	15 ft (4.5)	.035-5/64 in (0.9-2.0 mm)	KP2745-116	KP2747-1	KP2743-1-62R	KP2773-1	KP44-116-15	KP4694-60
K4857-2-10-116	15 ft (4.5)	.035-5/64 in (0.9-2.0 mm)						
K4857-2-3-116	15 ft (4.5)	.035-5/64 in (0.9-2.0 mm)						
K4857-4-1-116	25 ft (7.6)	.035-5/64 in (0.9-2.0 mm)						
K4857-4-10-116	25 ft (7.6)	.035-5/64 in (0.9-2.0 mm)						
K4857-4-3-116	25 ft (7.6)	.035-5/64 in (0.9-2.0 mm)						
K4858-2-1-564	15 ft (4.5)	.035-5/64 in (0.9-2.0 mm)	KP2745-564				KP44-564-15	KP4695-60
K4858-2-10-564	15 ft (4.5)	.035-5/64 in (0.9-2.0 mm)						
K4858-2-3-564	15 ft (4.5)	.035-5/64 in (0.9-2.0 mm)						

# INSTALLATION

Read this entire installation section before you start installation.

## WARNING

**SAFETY PRECAUTIONS**  
ELECTRIC SHOCK can kill.

- Do not touch electrically live parts such as output terminals or internal wiring.
- Insulate yourself from the work and ground.
- Always wear dry insulating gloves.



Only qualified personnel should install, use or service this equipment.

## WHAT'S INCLUDED

1. Coarse thread nozzle
2. Contact Tip
3. Diffuser
4. Coarse thread insulator
5. Gun Tube
6. Insulation Tube
7. Brass Cable Connector Set Screw
8. Brass hose nipple
9. Connector Cover
10. Molded gas plug fitting
11. Trigger Lead Connector
12. Trigger - 9SS21002

FIGURE 1

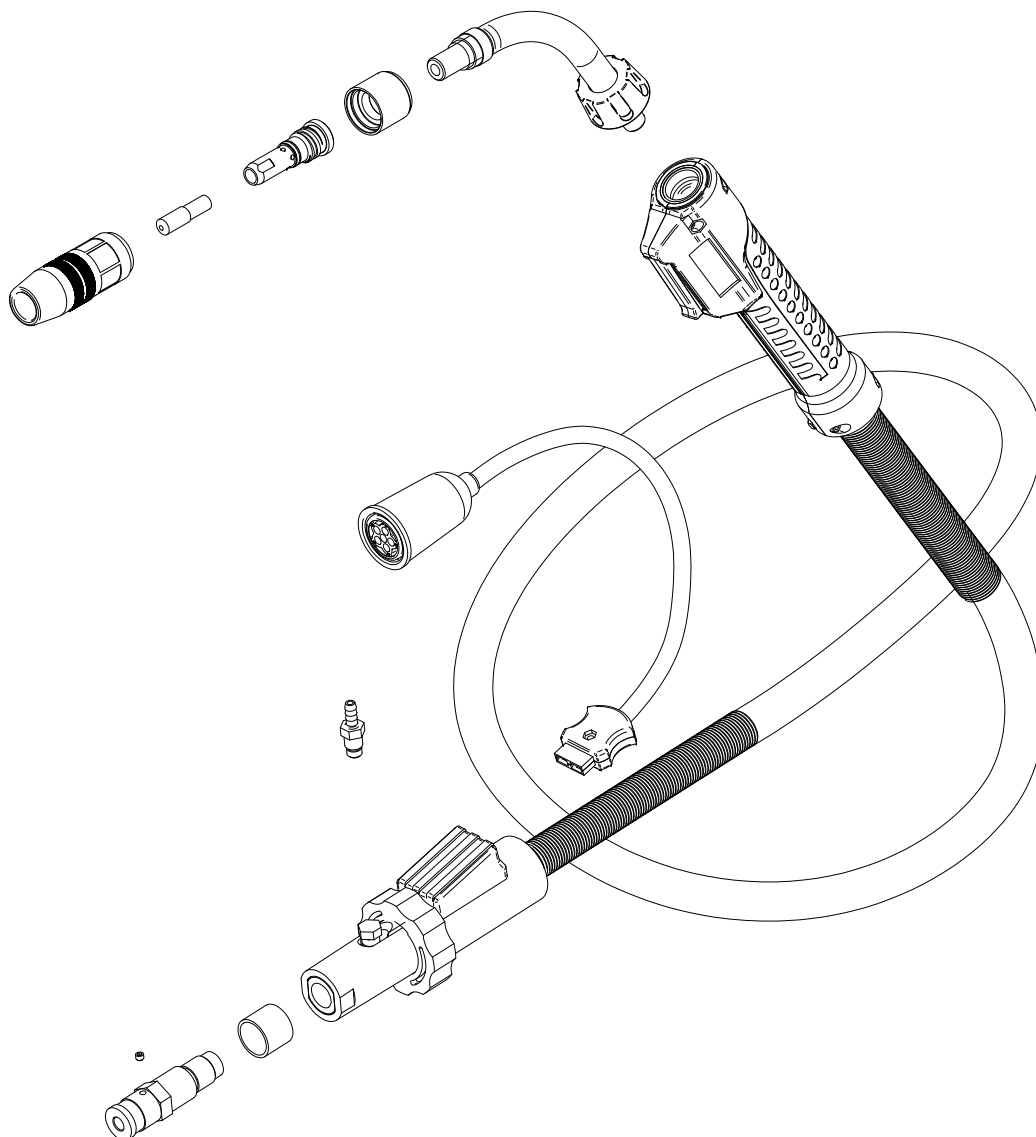

**CONNECTOR KIT INSTALLATION TO GUN CABLE**

The Magnum Pro Barrel HDE 250, 350 & 450 Guns are shipped as generic assemblies and must be assembled to a Magnum Connector Kit before they can be connected to a wire feeder. See Connector Kit Table on page A-1 for appropriate connector kit. **K466-1 and K466-8 Installation (for Lincoln Feeders)**

- a) Remove brass cable connector and insulation tube (see Figure 1) from the kit. Slide the insulation tube onto the connector from the threaded end and screw it onto the feeder end of the gun cable. Tighten the connection.
- b) Remove the molded gas plug fitting on the side of the feeder end handle and replace it with the barbed brass fitting provided in the kit.
- c) Attach the round connector of the gun control cable provided to the trigger connector on the front of the Lincoln feeder.

**NOTE:** Both the plug and socket are keyed must be properly oriented.

- d) Place one tubing clamp onto each end of the flexible tubing provided, approximately 2" (51 mm) in from each end. Slide one end of the tubing onto the barbed connector on the feeder end cable handle (step b) and move the clamp down near the end of the tube to assure a good gas seal.

**K466-2 Installation (For Tweco Adapted Feeders)**

- a) Remove brass cable connector (see Figure 1) from the K466-2 kit and screw it onto the feeder end of the gun cable. Tighten the connection.
- b) Check that the molded gas plug fitting is sealing the gas fitting hole in the side of the feeder end handle.

**K466-3 Installation (For Miller feeders)**

- a) Remove brass cable connector (see Figure 1) from the K466-3 kit and screw it on to the feeder end of the gun cable. Tighten the connection.
- b) Check that the molded gas plug fitting is sealing the gas fitting hole in the side of the feeder end handle.
- c) Attach the round connector of the gun control cable provided to the trigger connector on the front of the Miller feeder.

**K466-6 and K466-10 Installation (Wirematic and Lincoln 10 Series Feeders)**

- a) Remove brass cable connector (see Figure 1) from the connector kit and screw it onto the feeder end of the gun cable. Tighten the connection with the wrench provided.
- b) Check that the molded gas plug fitting is sealing the gas fitting hole in the side of the feeder end handle.
- c) Attach the gun control cable provided to the trigger connector on the front of the wire feeder.

**K613-1 Installation**

- a) Remove brass cable connector and insulation tube from the K613-1 Kit. Slide the insulation tube onto the connector from threaded end and screw it onto the feeder end of the gun cable. Tighten the connection.
- b) Remove the molded gas plug fitting on the side of the feeder end handle and replace it with the barbed brass fitting provided in the kit.
- c) Attach the round connector of the gun control cable provided to the trigger connector on the front of the Lincoln Feeder.

**Note:** Both the plug and socket are keyed and must be properly oriented.

- d) Place one tubing clamp onto each end of the flexible tubing provided, approximately 2" (51 mm) in from each end. Slide one end of the tubing onto the barbed connector on the feeder end cable handle (step b) and move the clamp down near the end of the tube to assure a good gas seal.

**K613-3 Installation**

- a) Remove brass cable connector from the K613-3 kit and screw it on to the feeder end of the gun cable. Tighten the connection.
- b) Check that the molded gas plug fitting is sealing the gas fitting hole in the side of the feeder end handle.
- c) Attach the round connector of the gun control cable provided to the trigger connector on the front of the Miller feeder.

**K613-2, K613-7 Installation**

- a) Remove brass cable connector from the kit and screw it onto the feeder end of the gun tube, Tighten the connection with wrench provided.
- b) For K613-7, attach the round connector of the gun control cable provided to the trigger connector on the front of the Lincoln feeder.

**K613-6 Installation**

- a) Remove brass connector and insulation tube from the kit. Slide the insulation tube onto the connector from the threaded end and screw it onto the feeder end of the gun cable. Tighten the connection with the wrench provided.
- b) Attach the round connector of the gun control cable provided to the trigger connector on the front of the Lincoln Feeder.

## LINER INSTALLATION AND TRIMMING INSTRUCTIONS

Installation of (KP42, KP44 and KP45 series liners)

- Lay the gun and cable straight on a flat surface.
- Make sure that the set screw in the connector end is backed out so as not to damage liner or liner bushing. Note: Magnum Pro diffusers don't have set screws. Remove and save the gas nozzle, nozzle insulator, and gas diffuser from the end of the gun tube assembly.
- Insert a new untrimmed liner into the connector end of the cable. Be sure the liner bushing is stenciled appropriately for the wire size being used.
- Be sure the cable is straight and then insert a new untrimmed liner into the connector end of the cable.
- Back out the set screw in the connector end and tighten manually.
- Trim the liner 0.75 in from the top of the gun tube. Remove any burrs from the end of the liner.

If needed replace the insulator and gas diffuser and place them on the end of the gun tube and tighten. Replace the gas nozzle.

### CAUTION

This screw should only be gently tightened. Overtightening will split or collapse the liner and cause poor wire feeding.

## ROTATING THE GUN TUBE

The gun tube can be rotated to any position desired by the operator. Loosen the front insert molded gun tube piece, rotate the gun tube to the desired position and retighten the nut with hands.

## CONTACT TIP AND GAS NOZZLE INSTALLATION

- Choose the correct size contact tip for the electrode being used (wire size is stenciled on the side of the contact tip) and screw it snugly into the gas diffuser.
- Be sure the nozzle insulator is fully screwed onto the gun tube and does not block the gas holes in the diffuser.
- Slip the appropriate gas nozzle onto the nozzle insulator. Adjustable gas nozzles are available with a .62" (15.9 mm) or .50" (12.7 mm) I.D., and in both standard (flush) and recessed design. The proper nozzle should be selected based on the welding application. Different length fixed nozzles are also available to allow either spray or short-circuiting transfer welding. Choose the gas nozzle as appropriate for the GMAW process to be used. Typically, the contact tip end should be flush to .12" (3.1 mm) extended for the short-circuiting transfer process and .12" (3.1 mm) recessed for spray transfer. For the Outershield (FCAW) process, 1/8" (3 mm) recess is recommended.

## CONNECTION TO FEEDER

### Connection to Lincoln Feeders

Gun cable assemblies which were assembled with a K466-1 or -8 Connection Kit will connect easily to any Lincoln LN-7, LN-8, LN-9, SP-200 or LN-25 feeder.

- Check that the drive roll(s) and feeder guide tubes are appropriate for the electrode size being used.
- Fully push the brass connector end of the gun cable into the conductor block on the outgoing side of the feeder wire drive. Secure the cable using the hand screw or set screw in the conductor block.
- Insert the control cable plug from the feeder trigger circuit into the mating socket on the feeder end cable handle (See K466-1 Installation Section).
- Slide the free end of the flexible hose onto the barbed gas fitting on the front of the Lincoln feeder (See K466-1 or -8 Installation Section.) Move the corresponding tubing clamp down near the end of the tube to assure a good gas seal.

### Connection to Tweco Adapted Feeders

Gun cable assemblies which were assembled with a K466-2 Connection Kit will connect easily to any properly adapted feeder.

- Check that the adapter and feeder outgoing guide, as well as the drive roll, are appropriate for the electrode size being used.
- Fully push the brass connector end of the gun cable into the brass adapter on the outgoing side of the feeder wire drive. Secure the cable using the hand screw or set screw in the adapter.
- Insert the control cable plug from the feeder trigger circuit into the mating socket on the gun cable connector handle.

### Connection to Miller Feeders

Gun and cable assemblies which were assembled with a K466-3 connection kit will connect easily to a variety of popular Miller wire feeders.

- a. Check that the gun liner, connector cap liner, driverolls and guide tubes are appropriate for the electrode size being used.
- b. Fully push the brass connector end of the gun and cable into the connector receptacle on the outgoing side of the feeder wire drive. Tighten the hand screw to clamp down on the connector.
- c. Insert the control cable plug from the feeder trigger circuit into the mating socket on the gun cable connector hand

---

### Connection To Power MIG® Series, Power Wave®

Gun cable assemblies which were assembled with a K466-6, Connection Kit will connect easily to a feeder.

- a. Check that the adapter and feeder outgoing guide, as well as the drive roll, are appropriate for the electrode size being used.
- b. Fully push the brass connector end of the gun cable into the outgoing side of the feeder wire drive. Secure the cable using the hand screw on the wire feeder.
- c. Insert the control cable plug from the feeder trigger circuit into the mating socket on the gun cable connector handle.

---

### Connection To Lincoln 10 Series Feeders

Gun cable assemblies which were assembled with a K466-10 Connection Kit gun and cable assemblies will connect easily to a 10 Series feeder.

- a. Check that the K1500-2 gun adapter is in place on the wire feeder. Check that the feeder guide tubes, as well as the drive roll(s), are appropriate for the electrode size being used.
- b. Fully push the brass connector end of the gun cable into the gun adapter on the outgoing side of the feeder wire drive and secure the cable using the hand screw.
- c. Insert the control cable plug from the feeder trigger circuit into the mating socket on the gun cable connector handle.

# OPERATION

Do not attempt to use this equipment until you have thoroughly read all operating and maintenance manuals supplied with your machine. They include important safety precautions, detailed engine starting, operating and maintenance instructions and parts lists.

## WARNING

### ELECTRIC SHOCK can kill.

- Do not touch electrically live parts such as output terminals or internal wiring.
- Insulate yourself from the work and ground.
- Always wear dry insulating gloves.

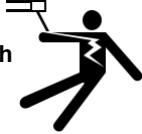

### FUMES AND GASES can be dangerous.

- Keep your head out of fumes.
- Use ventilation or exhaust to remove fumes from breathing zone.



### WELDING SPARKS can cause fire or explosion.

- Keep flammable material away.



### ARC RAYS can burn.

- Wear eye, ear and body protection.



Only qualified personnel should operate this equipment.

## ELECTRODES AND EQUIPMENT

The MAGNUM® PRO CURVE HDE 250-350-450 & 550 guns and cables have been designed for use with Lincoln L-50 and L-56, solid steel wire, Lincoln Outershield cored electrodes for the gas-shielded FCAW process. Refer to the appropriate Lincoln Process and Procedure Guidelines for the electrode used for information on recommended electrical and visible stickouts.

## MAKING A WELD

### WARNING

WHEN USING AN OPEN ARC PROCESS, IT IS NECESSARY TO USE CORRECT EYE, HEAD, AND BODY PROTECTION.

- Check that the welding power source is on and that the shielding gas supply is set for the proper flow rate.
- Position electrode over joint. End of the electrode should be slightly off the work.
- Lower welding helmet, close gun trigger, and begin welding. Hold the gun so the contact tip to work distance gives the correct electrical stickout as required for the procedure being used.
- To stop welding, release the gun trigger and then pull the gun away from the work after the arc goes out.
- If the optional interlocking trigger is installed, the trigger operates as follows:
  - Pull the trigger in to engage the feeder.
  - With the trigger pulled in all the way, the trigger can be slid forward into the interlock position.
  - To release interlock, squeeze trigger and pull back.

## AVOIDING WIRE FEEDING PROBLEMS

Wire feeding problems can be avoided by observing the following gun handling procedures:

- Do not kink or pull cable around sharp corners.
- Keep the electrode cable as straight as possible when welding or loading electrode through cable.
- Avoid wrapping excess cable around handle or front of wire feeder especially on 25 foot (7.5 m) length guns.
- Do not allow dolly wheels or trucks to run over cables.
- Keep cable clean by following maintenance instructions.
- Use only clean, rust-free electrode. The Lincoln electrodes have proper surface lubrication.
- Replace contact tip when the arc starts to become unstable or the contact tip end is fused or deformed.

MAGNUM® PRO BARREL 250 & 350 GUNS

CONTACT TIP 350 A				
Wire Diameter In (mm)	Standard	Standard	Tapered Tip	Tapered Tip
	Pkg. Qty. -10	Pkg. Qty. -100	Pkg. Qty. -10	Pkg. Qty. -100
0.025 (0.6)	KP2744-025	KP2744-025-B100	KP2744-025T	KP2744-025T-B100
0.030 (0.8)	KP2744-030	KP2744-030-B100	KP2744-030T	KP2744-030T-B100
0.035 (0.9)	KP2744-035	KP2744-035-B100	KP2744-035T	KP2744-035T-B100
0.040 (1.0)	KP2744-040	KP2744-040-B100	KP2744-040T	KP2744-040T-B100
0.045 (1.2)	KP2744-045	KP2744-045-B100	KP2744-045T	KP2744-045T-B100
0.052 (1.3)	KP2744-052	KP2744-052-B100	KP2744-052T	KP2744-052T-B100
1/16 (1.6)	KP2744-116	KP2744-116-B100	KP2744-116T	KP2744-116T-B100
5/64 (2.0)	KP2744-564	KP2744-564-B100	KP2744-564T	KP2744-564T-B100

GAS DIFFUSER 350 A			
Pkg. Qty	Thread-on Standard duty	Thread-on Extended Reach	Slip-On
1	KP2746-1	KP3360-1	KP2746-2
25	KP2746-1-B25	KP3360-1	KP2746-2

GUN TUBE INSULATOR 350 A	
Pkg. Qty	Part Number
1	KP2746-1
25	KP2746-1-B25

GAS NOZZLE 350 A							
Gas Nozzle Diameter In. (mm)							
	Nozzle	Pkg. Qty.	Standard 0.375 (9.5)	Standard 0.5 (12.7)	Extended Reach 0.5 (12.7)	Bottleneck 0.5 (12.7)	Standard 0.625 (15.9)
On	1/8 (3.2) Recess	1	KP2742-1-38R	KP2742-1-50R	KP3359-1-50R	KP3160-1-50R	KP2742-1-62R
		25	KP2742-1-38R-B25	KP2742-1-50R-B25	KP3359-1-50R-B25	KP3160-1-50R-B25	KP2742-1-62R-B25
	Flush	1	KP2742-1-38F	KP2742-1-50F	---	KP3160-1-50F	KP2742-1-62F
		25	KP2742-1-38F-B25	KP2742-1-50F-B25	---	KP3160-1-50F-B25	KP2742-1-62F-B25
	1/8 (3.2) Stickout	1	KP2742-1-38S	KP2742-1-50S	---	KP3160-1-50S	KP2742-1-62S
		25	KP2742-1-38S-B25	KP2742-1-50S-B25	---	KP3160-1-50S-B25	KP2742-1-62S-B25
Slip-On	1/8 (3.2) Recess	1	---	KP2742-2-50R	---	---	KP2742-2-62R
		25	---	KP2742-2-50R-B25	---	---	KP2742-2-62R-B25
	Flush	1	---	KP2742-2-50F	---	---	KP2742-2-62F
		25	---	KP2742-2-50F-B25	---	---	KP2742-2-62F-B25
	1/8 (3.2) Stickout	1	---	KP2742-2-50S	---	---	KP2742-2-62S
		25	---	KP2742-2-50S-B25	---	---	KP2742-2-62S-B25

**MAGNUM® PRO BARREL 450 & 550 GUNS**

<b>CONTACT TIP 550 A</b>						
Wire Diameter In (mm)	Standard	Standard	Extended Life	Extended Life	Magnum PRO Tapered	Magnum PRO Tapered
	Pkg. Qty. -10	Pkg. Qty. -100	Pkg. Qty. -10	Pkg. Qty. -100	Pkg. Qty. -10	Pkg. Qty. -100
0.035 (0.9)	KP2745-035	KP2745-035-B 100	KP2745-03 5R	KP2745-035R-B100	KP2745-035T	KP2745-035T-B100
0.040 (1.0)	KP2745-040	KP2745-040-B 100	NA	NA	KP2745-040T	KP2745-040T-B 100
0.045 (1.2)	KP2745-045	KP2745-045-B 100	KP2745-04 5R	KP2745-045R-B100	KP2745-045T	KP2745-045T-B 100
0.052 (1.3)	KP2745-052	KP2745-052-B 100	KP2745-05 2R	KP2745-052R-B100	KP2745-052T	KP2745-052T-B 100
1/16 (1.6)	KP2745-116	KP2745-116-B 100	KP2745-116R	KP2745-116R-B100	KP2745-116T	KP2745-116T-B 100
0.068-0.072 (1.7-1.8)	KP2745-072	KP2745-072-B100	KP2745-072R	KP2745-072R-B100	---	---
5/64 (2.0)	KP2745-564	KP2745-564-B 100	KP2745-56 4R	KP2745-564R-B100	---	---
3/32 (2.4)	KP2745-332	KP2745-332-B 100	KP2745-33 2R	KP2745-332R-B100	---	---
7/64 (2.8)	KP2745-764	KP2745-764-B 100	KP2745-76 4R	KP2745-764R-B100	---	---
1/8 (3.2)	KP2745-18	KP2745-18-B 100	NA	NA	---	---

<b>GAS DIFFUSER 550 A</b>			
Pkg. Qty	Thread-on Standard duty	Thread-on 1/4 In Recess	Slip-On
1	KP2747-1	KP3155-1	KP2747-2
25	KP2747-1-B25	KP3155-1-B25	KP2747-2-B25

<b>GUN TUBE INSULATOR 550 A</b>	
Pkg. Qty	Part Number
1	KP2773-1
25	KP2773-1-B25

<b>GUN TUBE</b>	
GUN TUBE	60° Gun Tube
Magnum® Pro 250	KP4695-1
Magnum® Pro 350	KP4695-2

<b>GAS NOZZLE 550 A</b>							
	Nozzle	Pkg. Qty.	Standard 0.625 (15.9)	Bottleneck 0.625 (15.9)	Standard 0.750 (19)	Gas Nozzle Diameter In. (mm) Magnum Pro Nozzle, 550A 0.375 (9.5)	Gas Nozzle Diameter In. (mm) Magnum Pro Nozzle, 550A 0.500 (12.7)
⊘	1/8 (3.2) Recess	1	KP2743-1-62R	KP3161-1-62R	KP2743-1-75R	KP2743-1-38R	KP2743-1-50R
		25	KP2743-1-62R-B25	KP3161-1-62R-B25	KP2743-1-75R-B25	KP2743-1-38R-B25	KP2743-1-50R-B25
	Flush	1	KP2743-1-62F	KP3161-1-62F	KP2743-1-75F	KP2743-1-38F	KP2743-1-50F
		25	KP2743-1-62F-B25	KP3161-1-62F-B25	KP2743-1-75F-B25	KP2743-1-38F-B25	KP2743-1-50F-B25
	1/8 (3.2) Stickout	1	KP2743-1-62S	KP3161-1-62S	KP2743-1-75S	KP2743-1-38S	KP2743-1-50S
		25	KP2743-1-62S-B25	KP3161-1-62S-B25	KP2743-1-75S-B25	KP2743-1-38S-B25	KP2743-1-50S-B25
Slip-On	1/8 (3.2) Recess	1	KP2743-2-62R	---	KP2743-2-75R	---	---
		25	KP2743-2-62R-B25	---	KP2743-2-75R-B25	---	---
	Flush	1	KP2743-2-62F	---	KP2743-2-75F	---	---
		25	KP2743-2-62F-B25	---	KP2743-2-75F-B25	---	---
	1/8 (3.2) Stickout	1	KP2743-2-62S	---	KP2743-2-75S	---	---
		25	KP2743-2-62S-B25	---	KP2743-2-75S-B25	---	---

	Nozzle	Magnum PRO Heavy Duty Nozzle Front End 0.625 (15.8)	Magnum PRO Heavy Duty Nozzle Front End 0.750 (19)	Pkg. Qty.	Magnum PRO Heavy Duty Nozzle Body
⊘	Flush	KP3583-1-62F	KP3583-1-75F	1	KP3582-1 KP3582-1-B25 (25 pc)
		KP3583-1-62F-B25	KP3583-1-75F-B25	25	
	1/8 (3.2) Recess	KP3583-1-62R	KP3583-1-75R	1	
		KP3583-1-62R-B25	KP3583-1-75R-B25	25	
	1/8 (3.2) Stickout	KP3583-1-62S	KP3583-1-75S	1	
		KP3583-1-62S-B25	KP3583-1-75S-B25	25	



# MAINTENANCE

## REMOVAL, INSTALLATION AND TRIMMING GUN LINERS

**NOTICE:** The variation in cable lengths prevents the interchange-ability of liners. Once a liner has been cut for a particular gun, it should not be installed in another gun, unless it can meet the liner cut off length requirement. Liners are shipped with the jacket of the liner extended the proper amount.

- Remove the gas nozzle and nozzle insulator. Loosen the set screw located in the side of the diffuser with 5/64" (2.0 mm) Allen wrench (provided with the gun or connector kit).
- Remove the gas diffuser from gun.
- Lay gun and cable out straight on a flat surface. For all K466 except K466-3 and K466-4 Connections:  
Loosen set screw located in the brass cable connector at the wire feeder end of the cable using the same 5/64" (2.0 mm) Allen wrench. Pull liner out of cable.

<OR>

For K466-3 CONNECTIONS:

Remove the connector cap with the wrench provided. Pull liner out of cable. If the liner is going to be replaced with a different size liner, loosen set screw on the connector cap and remove piece of liner material.

- For installation and trimming instructions for liners see "LINER INSTALLATION" in INSTALLATION section.

## GUN TUBES AND NOZZLES

- Replace worn contact tips as required.
- Remove spatter from inside of gas nozzle and from tip after each 10 minutes of arc time or as required.
- Unscrew the guntube using the gooseneck nut.  
Pull gun tube out from gun handle. To reinstall, insert the gun tube, push in as far as possible, and re-tighten the gooseneck nut.

## GUN CABLES

### Cable Cleaning

Clean cable liner after using approximately 300 (136 kg) pounds of electrode.

Remove the cable from the wire feeder and lay it out straight on the floor. Remove the contact tip from the gun. Using an air hose and only partial pressure, gently blow out the cable liner from the gas diffuser end.

Flex the cable over its entire length and again blow out the cable. Repeat this procedure until no further dirt comes out.



**CAUTION**

Excessive pressure at the start may cause the dirt to form a plug.

## CABLE REPAIR

The MAGNUM® PRO BARREL HDE 250-350 & 450 guns feature the use of repairable cable connectors. If the cable ever gets severely damaged, it may be cut shorter and repaired by the user. Repair cables as follows:

### Gun Tube End Repair

(Requires 2 S19492-2 Terminals)

- Remove the cable liner per Removal, Installation and Trimming Instructions.
- Remove the gun tube per Gun Tubes and Nozzles Section.
- Remove four #6 screws from the gun handle, separate the two halves, and remove the cable from the handle along with the trigger assembly.
- Remove gun tube connector from cable by unscrewing connector nut from gun tube connector. If the cable inner tube is difficult to remove from the connector assembly, carefully slit it lengthwise with a knife up to the brass connector.
- Uncouple the strain relief by pushing its outer housing toward the middle of the cable. Move the strain relief and the cable boot toward the middle of the cable, past the damaged section.
- Cut off the damaged section of cable and strip off the outer jacket as shown in Figure 2. Be careful not to cut the insulation on the control wires while stripping jacket. Strip the red and white control leads 1/4 inch (6.4 mm) from the end and crimp a new S19492-2 terminal to each lead.

**NOTE:** The cable contains control leads. Any two control leads can be used, provided the two colors used are the same at both ends. The extra leads are a spare that can be used if one of the other leads breaks.

- Check that the cable boot and both halves of the strain relief are on the cable. Slip the connector nut over the copper strands with the thread end out. Orient gun tube connector so machined flat is on the same side of the cable as the red and white control leads.

Assemble gun tube connector to cable by forcing the steel tube of the connector into the inside diameter of the cable inner tube until the copper strands are butted against the gun tube connector shoulder. Keeping the copper strands against the shoulder, pull the connector nut over the copper strands, engage the gun tube connector threads, and tighten in place. Refer to Figure 3.

NOTE: For best results, insert a .219"/.240" (5.6/6.1 mm) diameter rod through the connector and into core of cable approximately 5.00 (127 mm) when pushing the connector tube into the cable core tube. To tighten, hold the connector in place while turning the nut, then remove the rod from the core. This procedure ensures the inner core does not kink while assembling or tightening.

- h. Pull the cut-off lead terminals off the trigger assembly and connect the replacement control lead terminals.
- i. Position the cable boot and strain relief on the cable so it fits in cable handle cavity and lock the strain relief in place by pushing the two halves together.
- j. Assemble cable in left side of gun handle. Assemble trigger into the proper handle cavity. Assemble right side of gun handle and tighten the three screws that hold the handle together. Refer to Figure 4.
- k. Install gun tube per Gun Tubes and Nozzles Section.
- l. Install and trim liner per Liner Installation Section.

FIGURE 2 – 250 & 350 AMPS

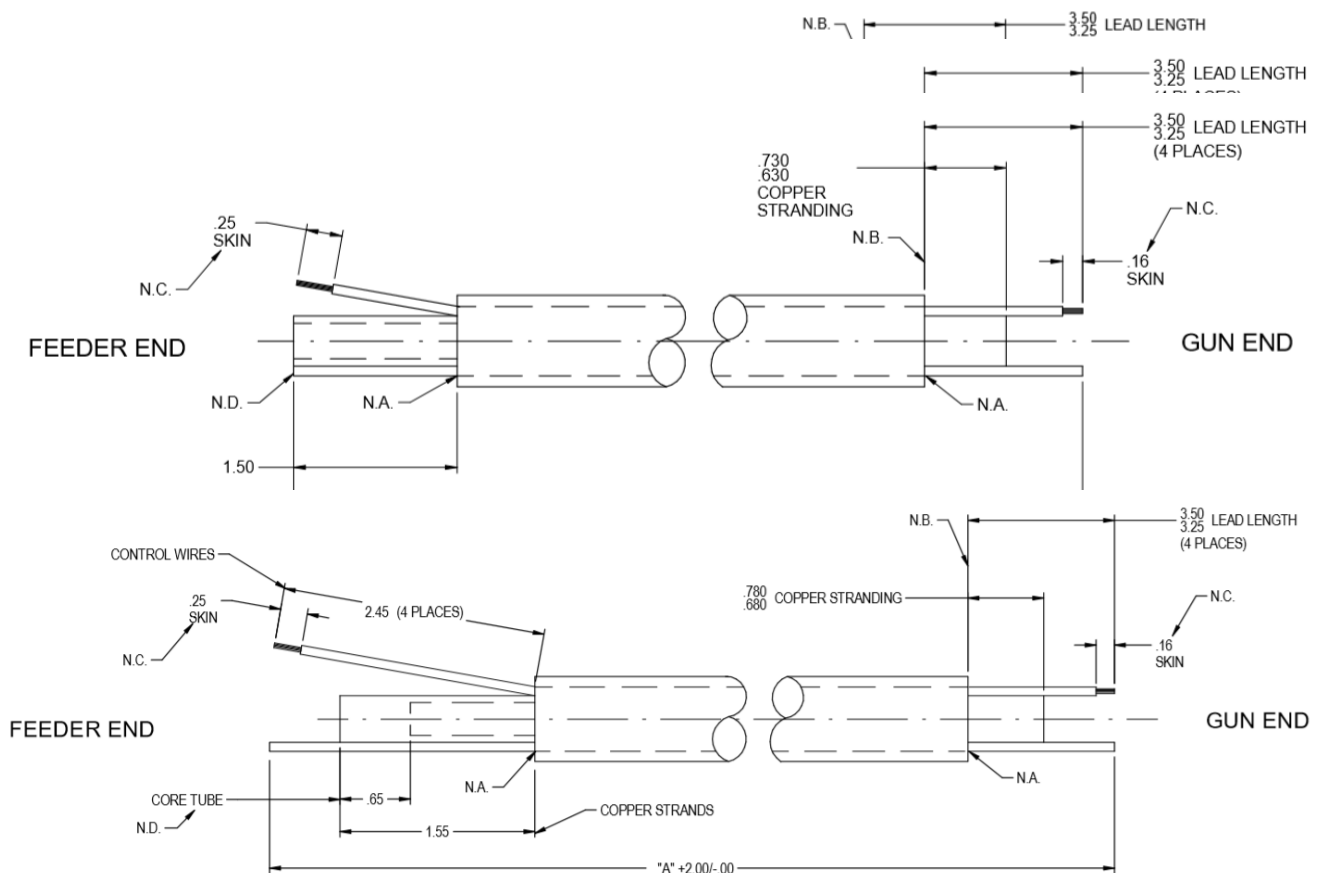

FIGURE 2 - 550

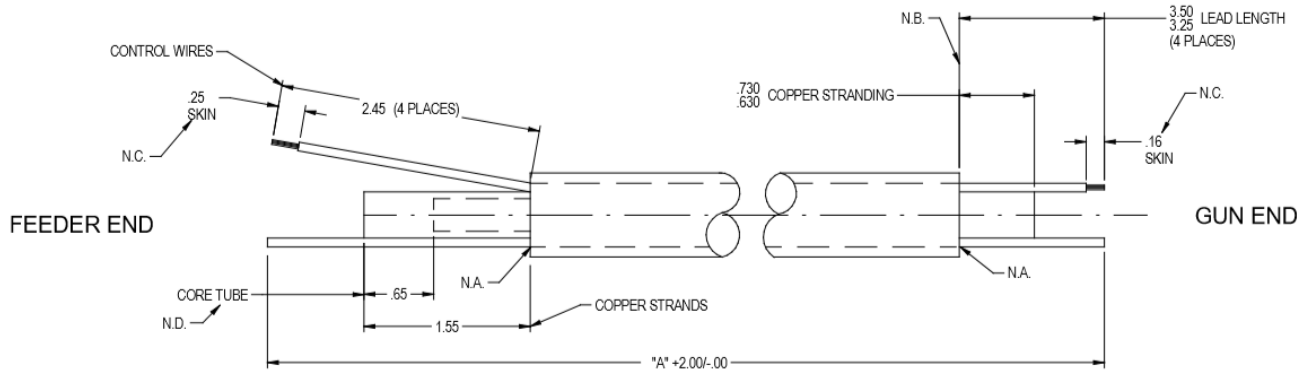
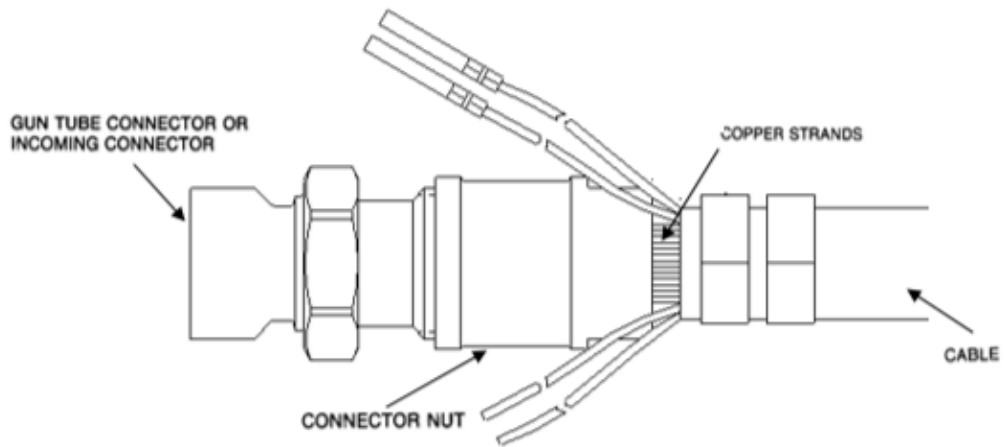

FIGURE 3



**Wire Feeder End Repair**

(REQUIRES 2 #S19492-1 TERMINALS)

- a. Remove the cable liner per Removal, Installation, and Trimming Instruction.
- b. Remove the feeder end connector, molded gas plug (or barbed fitting), cable handle nut, plastic tailpiece and connector cover (see Figure 5).

**NOTE:** In order to remove the cable handle nut, the tail of the connector cover must be depressed and the cable handle nut rotated 1/4 turn counterclockwise as viewed from the feeder end.

- c. Remove incoming connector from cable by unscrewing connector nut from incoming connector.  
If the cable inner tube is difficult to remove from the connector assembly, carefully slit it lengthwise with a knife up to the brass connector.
- d. Move the cable boot and cable handle toward the middle of the cable past the damaged section.
- e. Cut off the damaged section of cable and strip off the outer jacket as shown in Figure 2. Be careful not to cut the insulation on the control wiring while stripping jacket. Strip the red and white control leads 1/4 inch (6.4 mm) from the end and crimp a new S19492-1 terminal to each lead.

**NOTE:** The cable contains three control leads. Any two control leads can be used, provided the two colors used are the same at both ends. The extra lead is a spare that can be used if one of the other leads breaks.

- f. Check that the cable boot and cable handle are on the cable. Slip the connector nut over the copper strands with the threaded end out. Assemble incoming connector to cable by forcing the steel tube of the connector into the inside diameter of the cable inner tube until the copper strands are butted against the incoming connector shoulder. Keeping the copper strands against the shoulder, pull the connector nut over the copper strands, engage the incoming connector threads, and tighten in place. Refer to Figure 3.

**NOTE:** For best results, insert a .219"/.240" (5.6/6.1 mm) diameter rod through the connector and into core of cable approximately 5.00" (127 mm) when pushing the connector tube into the cable core tube. To tighten, hold the connector in place while turning the nut. Then remove the rod from the core. This procedure ensures the inner core does not kink while assembling or tightening.

- Position the plastic strain relief such that the tapered end is 4.68 (119 mm) from the incoming connector (see Figure 5). Lock into place with steel housing. Plastic strain relief may overhang cable jacket a maximum of .43" (11 mm).
- g. Position cable boot and cable handle on cable and assemble replacement control wire terminals in place on the cable handle. Insert connector cover in place. Install tailpiece and fasten to cable handle with cable handle nut. Refer to Figure 5.
  - h. Replace the molded gas plug (or barbed fitting) and feeder end connector.
  - i. Install and trim liner per Liner Installation Section.

FIGURE 4

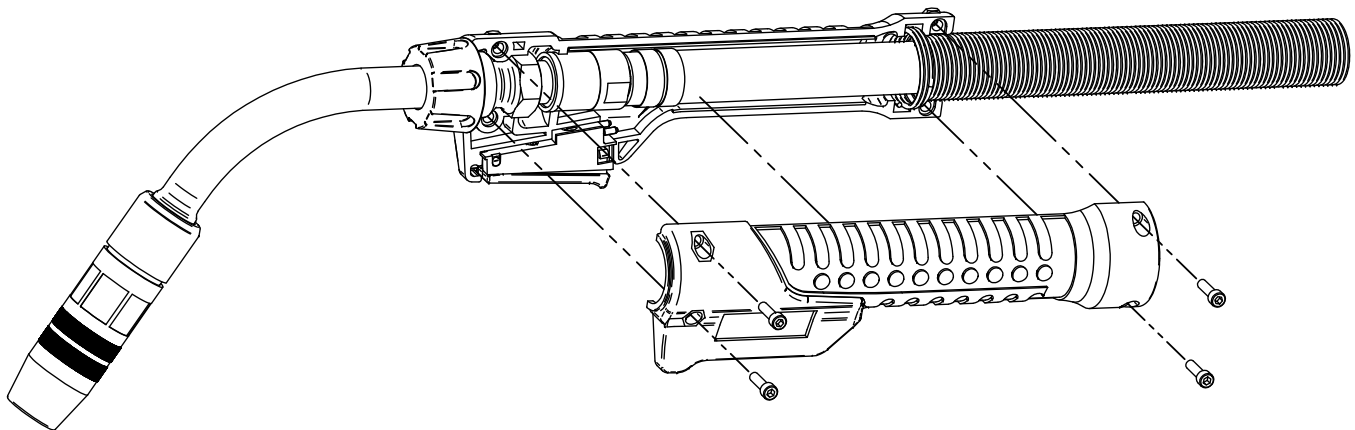
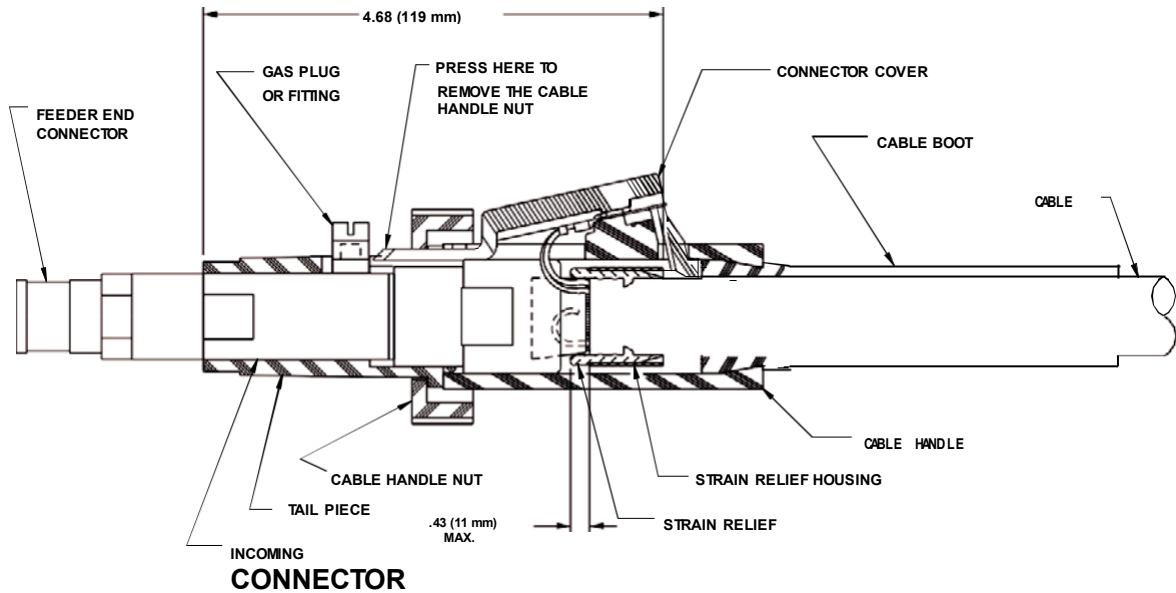

FIGURE 5



### Wire Feeder End Repair

- Remove the cable liner per "Removal, Installation and Trimming Instructions for Magnum® Liners".
  - Loosen the boot nut. Slide the boot nut and boot toward the middle of the cable past the damaged section.
  - Rotate the collar nut until the screw anchoring the cable handle is visible. Remove the screw and save it.
  - Slide the cable handle, collar nut and strain relief housing toward the middle of the cable past the damaged section. On older cables remove and save the cable clamp that was used in place of the strain relief.
- NOTE:** If sliding the cable handle becomes difficult, try rotating it 180°.
- Remove the incoming connector from the cable by unscrewing the connector nut from the incoming connector. If the cable inner tube is difficult to remove from the connector assembly, carefully slit it lengthwise with a knife up to the brass connector.
  - Cut the cable control wires where they meet the cable jacket or else unsolder the connection where they connect to the terminal lead assembly. If you cut the wires, strip the cut end 3/8 inch (9.5 mm) from the end.
  - Cut off the damaged section of cable and strip off the outer jacket as shown in Figure 2. Be careful not to cut the insulation on the control wires while stripping the jacket. Strip the red and white control leads 3/8 inch (9.5 mm) from the end.

**NOTE:** The cable contains four control leads. Any two control leads can be used, provided the two colors used are the same at both ends. The extra lead is a spare that can be used if one of the other leads breaks.

- Check that the cable boot, boot nut, cable handle, strain relief housing and collar nut are on the cable. Slip the connector nut over the copper strands with the threaded end out. Orient the connector assembly so the red and white control leads will have the straightest possible routings to the sockets on the back side of the connector. Assemble the incoming connector to the cable by forcing the steel tube of the connector into the inside diameter of the cable inner tube until the copper strands are butted against the incoming connector shoulder. Keeping the copper strands against the shoulder, pull the connector nut over the copper strands, engage the incoming connector threads, and tighten in place.

Refer to Figure 3.

**NOTE:** For best results, insert a rod through the connector and into the core of the cable approximately 5.00" (127 mm) when pushing the connector tube into the cable core tube. A .219"/.240"

- (5.6-6.1 mm) diameter rod is required for 300 and 400 amp cables. To tighten, hold the connector in place while turning the nut, then remove the rod from the core. This procedure assures the inner core does not kink while assembling or tightening.

- j) Fully insert the two control lead pins into the sockets on the incoming connector. Tape the leads in place in the necked down area of the connector. Keeping the leads as close to the connector and nut as possible, tape the insulated, soldered connections and the spare lead to the cable in the area between the cable jacket and connector nut. This must be done neatly and kept as low as possible or the cable handle will not slide over this area.
- k) Position the strain relief to the dimension shown in Figure 6 and secure with the strain relief housing. On older cables install the cable clamp on the cable jacket within 1/8" (3.2 mm) from the end of the jacket and tighten.
- l) Slide the collar nut and cable handle over the connection and into place. Anchor the cable handle with the screw removed in step (c). Slide the boot and boot nut into place and tighten.

**NOTE:** If the cable handle becomes difficult to slide over connection, try rotating it.

# TROUBLESHOOTING

## HOW TO USE TROUBLESHOOTING GUIDE

### WARNING

Service and Repair should only be performed by Lincoln Electric Factory Trained Personnel. Unauthorized repairs performed on this equipment may result in danger to the technician and machine operator and will invalidate your factory warranty. For your safety and to avoid Electrical Shock, please observe all safety notes and precautions detailed throughout this manual.

This Troubleshooting Guide is provided to help you locate and repair possible machine malfunctions. Simply follow the three-step procedure listed below.

#### Step 1. LOCATE PROBLEM (SYMPTOM).

Look under the column labeled "PROBLEM (SYMPTOMS)." This column describes possible symptoms that the machine may exhibit. Find the listing that best describes the symptom that the machine is exhibiting.

#### Step 2. POSSIBLE CAUSE.

The second column labeled "POSSIBLE CAUSE" lists the obvious external possibilities that may contribute to the machine symptom.

#### Step 3. RECOMMENDED COURSE OF ACTION

This column provides a course of action for the Possible Cause, generally it states to contact your local Lincoln Authorized Field Service Facility.

If you do not understand or are unable to perform the Recommended Course of Action safely, contact your local Lincoln Authorized Field Service Facility.

### WARNING

#### ELECTRIC SHOCK can kill.

- Turn off machine at the disconnect switch on the rear of the machine and remove main power supply connections before doing any troubleshooting.



If for any reason you do not understand the test procedures or are unable to perform the tests/repairs safely, contact your Lincoln Authorized Service Facility for technical troubleshooting assistance before you proceed.

**WWW.LINCOLNELECTRIC.COM/LOCATOR**

Observe all Safety Guidelines detailed throughout this manual

PROBLEM (SYMPTOMS)	POSSIBLE AREAS OF MISADJUSTMENT(S)	RECOMMENDED COURSE OF ACTION
Drive rolls turn, but wire will not feed or wire feeding is rough.	Gun cable kinked and/or twisted.	Keep as straight as possible. Inspect cable and replace if necessary.
	Wire jammed in gun and cable.	Remove wire from gun and cable - feed in new wire. Note any obstruction. Replace liner if necessary.
	Incorrect drive rolls and guide tubes.	Be sure the wire diameter being used is stamped on drive rolls and guide tubes. Replace if necessary.
	Gun cable liner dirty.	Clean liner or replace.
	Worn drive rolls.	Replace or reverse split drive roll type.
	Electrode rusty and/or dirty.	Replace the electrode if it is rusty.
	Worn or improper size cable liner.	Replace cable liner.
Variable or "hunting" arc.	Contact tip worn or incorrect size.	Replace contact tip.
	Worn or undersize ground cables or poor ground connections.	Inspect - repair or replace as necessary.
	Loose electrode connections.	Be sure the following connections are tight: electrode cable to wire feeder and power source, work cable to power source and work, gun cable to wire feeder contact block, gun nozzle to body, and contact tip to nozzle.
Poor arc striking with sticking or "Blast-offs", weld porosity, narrow and ropy looking bead, or electrode stubbing into plate while welding.	Improper procedures or techniques.	See "Gas Metal Arc Welding Guide" (GS-100).
	Improper gas shielding.	Clean gas nozzle. Make certain that gas diffuser is not restricted. Make certain that gas cylinder is not empty or turned off. Make certain gas solenoid valve is operating and gas flow rate is proper. Remove gun liner and check rubber seal for any sign of deterioration or damage. Be sure set screw in brass connector is in place and tightened against the liner bushing.
Tip seizes in diffuser.	Tip overheating due to prolonged or excessive high current and/or duty cycle welding.	Do not exceed current and duty cycling of gun. A light application of high temperature antiseize lubricant (such as Lincoln E2067 Graphite Grease) may be applied to tip threads.



If for any reason you do not understand the test procedures or are unable to perform the tests/repairs safely, contact your Lincoln Authorized Service Facility for technical troubleshooting assistance before you proceed.

[WWW.LINCOLNELECTRIC.COM/LOCATOR](http://WWW.LINCOLNELECTRIC.COM/LOCATOR)



			
<b>WARNING</b>	<ul style="list-style-type: none"> <li>● Do not touch electrically live parts or electrode with skin or wet clothing.</li> <li>● Insulate yourself from work and ground.</li> </ul>	<ul style="list-style-type: none"> <li>● Keep flammable materials away.</li> </ul>	<ul style="list-style-type: none"> <li>● Wear eye, ear and body protection.</li> </ul>
Spanish <b>AVISO DE PRECAUCION</b>	<ul style="list-style-type: none"> <li>● No toque las partes o los electrodos bajo carga con la piel o ropa mojada.</li> <li>● Aíslese del trabajo y de la tierra.</li> </ul>	<ul style="list-style-type: none"> <li>● Mantenga el material combustible fuera del área de trabajo.</li> </ul>	<ul style="list-style-type: none"> <li>● Protéjase los ojos, los oídos y el cuerpo.</li> </ul>
French <b>ATTENTION</b>	<ul style="list-style-type: none"> <li>● Ne laissez ni la peau ni des vêtements mouillés entrer en contact avec des pièces sous tension.</li> <li>● Isolez-vous du travail et de la terre.</li> </ul>	<ul style="list-style-type: none"> <li>● Gardez à l'écart de tout matériel inflammable.</li> </ul>	<ul style="list-style-type: none"> <li>● Protégez vos yeux, vos oreilles et votre corps.</li> </ul>
German <b>WARNUNG</b>	<ul style="list-style-type: none"> <li>● Berühren Sie keine stromführenden Teile oder Elektroden mit Ihrem Körper oder feuchter Kleidung!</li> <li>● Isolieren Sie sich von den Elektroden und dem Erdboden!</li> </ul>	<ul style="list-style-type: none"> <li>● Entfernen Sie brennbares Material!</li> </ul>	<ul style="list-style-type: none"> <li>● Tragen Sie Augen-, Ohren- und Körperschutz!</li> </ul>
Portuguese <b>ATENÇÃO</b>	<ul style="list-style-type: none"> <li>● Não toque partes elétricas e electrodos com a pele ou roupa molhada.</li> <li>● Isole-se da peça e terra.</li> </ul>	<ul style="list-style-type: none"> <li>● Mantenha inflamáveis bem guardados.</li> </ul>	<ul style="list-style-type: none"> <li>● Use proteção para a vista, ouvido e corpo.</li> </ul>
Japanese <b>注意事項</b>	<ul style="list-style-type: none"> <li>● 通電中の電気部品、又は溶材にヒフやぬれた布で触れないこと。</li> <li>● 施工物やアースから身体が絶縁されている様にして下さい。</li> </ul>	<ul style="list-style-type: none"> <li>● 燃えやすいものの側での溶接作業は絶対にしてはなりません。</li> </ul>	<ul style="list-style-type: none"> <li>● 目、耳及び身体に保護具をして下さい。</li> </ul>
Chinese <b>警告</b>	<ul style="list-style-type: none"> <li>● 皮肤或湿衣物切勿接触带电部件及焊条。</li> <li>● 使你自已与地面和工件绝缘。</li> </ul>	<ul style="list-style-type: none"> <li>● 把一切易燃物品移离工作场所。</li> </ul>	<ul style="list-style-type: none"> <li>● 佩戴眼、耳及身体劳动保护用具。</li> </ul>
Korean <b>위험</b>	<ul style="list-style-type: none"> <li>● 전도체나 용접봉을 젖은 형갑 또는 피부로 절대 접촉치 마십시오.</li> <li>● 모재와 접지를 접촉치 마십시오.</li> </ul>	<ul style="list-style-type: none"> <li>● 인화성 물질을 접근시키지 마십시오.</li> </ul>	<ul style="list-style-type: none"> <li>● 눈, 귀와 몸에 보호장구를 착용하십시오.</li> </ul>
Arabic <b>تحذير</b>	<ul style="list-style-type: none"> <li>● لا تلمس الاجزاء التي يسري فيها التيار الكهربائي أو الالكترود بجسدك أو بالملابس المبللة بالماء.</li> <li>● ضع عازلا على جسمك خلال العمل.</li> </ul>	<ul style="list-style-type: none"> <li>● ضع المواد القابلة للاشتعال في مكان بعيد.</li> </ul>	<ul style="list-style-type: none"> <li>● ضع أدوات وملابس واقية على عينيك وأذنيك وجسمك.</li> </ul>

**READ AND UNDERSTAND THE MANUFACTURER'S INSTRUCTION FOR THIS EQUIPMENT AND THE CONSUMABLES TO BE USED AND FOLLOW YOUR EMPLOYER'S SAFETY PRACTICES.**

**SE RECOMIENDA LEER Y ENTENDER LAS INSTRUCCIONES DEL FABRICANTE PARA EL USO DE ESTE EQUIPO Y LOS CONSUMIBLES QUE VA A UTILIZAR, SIGA LAS MEDIDAS DE SEGURIDAD DE SU SUPERVISOR.**

**LISEZ ET COMPRENEZ LES INSTRUCTIONS DU FABRICANT EN CE QUI REGARDE CET EQUIPMENT ET LES PRODUITS A ETRE EMPLOYES ET SUIVEZ LES PROCEDURES DE SECURITE DE VOTRE EMPLOYEUR.**

**LESEN SIE UND BEFOLGEN SIE DIE BETRIEBSANLEITUNG DER ANLAGE UND DEN ELEKTRODENEINSATZ DES HERSTELLERS. DIE UNFALLVERHÜTUNGSVORSCHRIFTEN DES ARBEITGEBERS SIND EBENFALLS ZU BEACHTEN.**

			
<ul style="list-style-type: none"> <li>● Keep your head out of fumes.</li> <li>● Use ventilation or exhaust to remove fumes from breathing zone.</li> </ul>	<ul style="list-style-type: none"> <li>● Turn power off before servicing.</li> </ul>	<ul style="list-style-type: none"> <li>● Do not operate with panel open or guards off.</li> </ul>	<b>WARNING</b>
<ul style="list-style-type: none"> <li>● Los humos fuera de la zona de respiración.</li> <li>● Mantenga la cabeza fuera de los humos. Utilice ventilación o aspiración para gases.</li> </ul>	<ul style="list-style-type: none"> <li>● Desconectar el cable de alimentación de poder de la máquina antes de iniciar cualquier servicio.</li> </ul>	<ul style="list-style-type: none"> <li>● No operar con panel abierto o guardas quitadas.</li> </ul>	Spanish <b>AVISO DE PRECAUCION</b>
<ul style="list-style-type: none"> <li>● Gardez la tête à l'écart des fumées.</li> <li>● Utilisez un ventilateur ou un aspirateur pour ôter les fumées des zones de travail.</li> </ul>	<ul style="list-style-type: none"> <li>● Débranchez le courant avant l'entretien.</li> </ul>	<ul style="list-style-type: none"> <li>● N'opérez pas avec les panneaux ouverts ou avec les dispositifs de protection enlevés.</li> </ul>	French <b>ATTENTION</b>
<ul style="list-style-type: none"> <li>● Vermeiden Sie das Einatmen von Schweißrauch!</li> <li>● Sorgen Sie für gute Be- und Entlüftung des Arbeitsplatzes!</li> </ul>	<ul style="list-style-type: none"> <li>● Strom vor Wartungsarbeiten abschalten! (Netzstrom völlig öffnen; Maschine anhalten!)</li> </ul>	<ul style="list-style-type: none"> <li>● Anlage nie ohne Schutzgehäuse oder Innenschutzverkleidung in Betrieb setzen!</li> </ul>	German <b>WARNUNG</b>
<ul style="list-style-type: none"> <li>● Mantenha seu rosto da fumaça.</li> <li>● Use ventilação e exaustão para remover fumo da zona respiratória.</li> </ul>	<ul style="list-style-type: none"> <li>● Não opere com as tampas removidas.</li> <li>● Desligue a corrente antes de fazer serviço.</li> <li>● Não toque as partes elétricas nuas.</li> </ul>	<ul style="list-style-type: none"> <li>● Mantenha-se afastado das partes moventes.</li> <li>● Não opere com os painéis abertos ou guardas removidas.</li> </ul>	Portuguese <b>ATENÇÃO</b>
<ul style="list-style-type: none"> <li>● ヒュームから頭を離すようにして下さい。</li> <li>● 換気や排煙に十分留意して下さい。</li> </ul>	<ul style="list-style-type: none"> <li>● メンテナンス・サービスに取りかかる際には、まず電源スイッチを必ず切して下さい。</li> </ul>	<ul style="list-style-type: none"> <li>● パネルやカバーを取り外したまま機械操作をしないで下さい。</li> </ul>	Japanese <b>注意事項</b>
<ul style="list-style-type: none"> <li>● 頭部遠離煙霧。</li> <li>● 在呼吸區使用通風或排風器除煙。</li> </ul>	<ul style="list-style-type: none"> <li>● 維修前切斷電源。</li> </ul>	<ul style="list-style-type: none"> <li>● 儀表板打開或沒有安全罩時不準作業。</li> </ul>	Chinese <b>警告</b>
<ul style="list-style-type: none"> <li>● 얼굴로부터 용접가스를 멀리하십시오.</li> <li>● 호흡지역으로부터 용접가스를 제거하기 위해 가스제거기나 통풍기를 사용하십시오.</li> </ul>	<ul style="list-style-type: none"> <li>● 보수전에 전원을 차단하십시오.</li> </ul>	<ul style="list-style-type: none"> <li>● 판넬이 열린 상태로 작동치 마십시오.</li> </ul>	Korean <b>위험</b>
<ul style="list-style-type: none"> <li>● ابعد رأسك بعيداً عن الدخان.</li> <li>● استعمل التهوية أو جهاز ضغط الدخان للخارج لكي تبعد الدخان عن المنطقة التي تتنفس فيها.</li> </ul>	<ul style="list-style-type: none"> <li>● اقطع التيار الكهربائي قبل القيام بأية صيانة.</li> </ul>	<ul style="list-style-type: none"> <li>● لا تشغيل هذا الجهاز اذا كانت الاغطية الحديدية الواقية ليست عليه.</li> </ul>	Arabic <b>تحذير</b>

**LEIA E COMPREENDA AS INSTRUÇÕES DO FABRICANTE PARA ESTE EQUIPAMENTO E AS PARTES DE USO, E SIGA AS PRÁTICAS DE SEGURANÇA DO EMPREGADOR.**

使う機械や溶材のメーカーの指示書をよく読み、まず理解して下さい。そして貴社の安全規定に従って下さい。

請詳細閱讀並理解製造廠提供的說明以及應該使用的銀焊材料，並請遵守貴方的有關勞動保護規定。

이 제품에 동봉된 작업지침서를 숙지하시고 귀사의 작업자 안전수칙을 준수하시기 바랍니다.

اقرأ بتمعن وافهم تعليمات المصنع المنتج لهذه المعدات والمواد قبل استعمالها واتبع تعليمات الوقاية لصاحب العمل.

## **CUSTOMER ASSISTANCE POLICY**

The business of The Lincoln Electric Company is manufacturing and selling high quality welding equipment, consumables, and cutting equipment. Our challenge is to meet the needs of our customers and to exceed their expectations. On occasion, purchasers may ask Lincoln Electric for advice or information about their use of our products. We respond to our customers based on the best information in our possession at that time. Lincoln Electric is not in a position to warrant or guarantee such advice, and assumes no liability, with respect to such information or advice. We expressly disclaim any warranty of any kind, including any warranty of fitness for any customer's particular purpose, with respect to such information or advice. As a matter of practical consideration, we also cannot assume any responsibility for updating or correcting any such information or advice once it has been given, nor does the provision of information or advice create, expand or alter any warranty with respect to the sale of our products.

Lincoln Electric is a responsive manufacturer, but the selection and use of specific products sold by Lincoln Electric is solely within the control of, and remains the sole responsibility of the customer. Many variables beyond the control of Lincoln Electric affect the results obtained in applying these types of fabrication methods and service requirements.

Subject to Change – This information is accurate to the best of our knowledge at the time of printing. Please refer to [www.lincolnelectric.com](http://www.lincolnelectric.com) for any updated information.



**THE LINCOLN ELECTRIC COMPANY**

22801 St. Clair Avenue • Cleveland, OH • 44117-1199 • U.S.A.  
Phone: +1.216.481.8100 • [www.lincolnelectric.com](http://www.lincolnelectric.com)