

PRESTOMIG 185MP & 210MP

OPERATOR'S MANUAL



ENGLISH



Lincoln Electric Bester Sp. z o.o.
ul. Jana III Sobieskiego 19A, 58-260 Bielawa, Poland

THANKS! For having chosen the QUALITY of the Lincoln Electric products.

- Please Examine Package and Equipment for Damage. Claims for material damaged in shipment must be notified immediately to the dealer.
- For future reference record in the table below your equipment identification information. Model Name, Code & Serial Number can be found on the machine rating plate.

Model Name:
Code & Serial number:
Date & Where Purchased:

ENGLISH INDEX

Technical Specifications	1
ECO design information	3
Electromagnetic Compatibility (EMC)	5
Safety	6
Introduction	8
Installation and Operator Instructions	8
WEEE	18
Spare Parts	18
REACH	18
Authorized Service Shops Location	18
Electrical Schematic	18
Accessories	19

Technical Specifications

NAME		INDEX				
PRESTOMIG 185MP		W000403577				
PRESTOMIG 210MP		W000403576				
INPUT						
	185MP	210MP				
Input Voltage U ₁	230 Vac ± 10%, 1-phase	115 Vac ± 10%, 1-phase	230 Vac ± 10%, 1-phase			
Frequency	50/60 Hz					
Input Amperes I _{1max}	27A	23A	27A			
Input Power at Rated Cycle (40°C)	6,2kVA @ 25% Duty Cycle	2,6kVA @ 40% Duty Cycle	6,2kVA @ 25% Duty Cycle			
cos φ	0,99					
EMC Group / Class	II / A					
RATED OUTPUT						
185MP		Open Circuit Voltage	Duty Cycle 40°C (based on a 10 min. period)	Output Current	Output Voltage	
185MP	GMAW	51 Vdc	100	110A	19,5 Vdc	
			60	160A	22 Vdc	
			25	200A	24 Vdc	
	FCAW-SS		100	110A	19,5 Vdc	
			60	160A	22 Vdc	
			25	200A	24 Vdc	
	SMAW		100	100A	24 Vdc	
			60	140A	25,6 Vdc	
			30	160A	26,4 Vdc	
210MP	230Vac	51 Vdc	100	110A	19,5 Vdc	
			60	160A	22 Vdc	
			25	200A	24 Vdc	
			100	110A	19,5 Vdc	
			60	160A	22 Vdc	
			25	200A	24 Vdc	
			100	100A	24 Vdc	
			60	140A	25,6 Vdc	
			30	160A	26,4 Vdc	
	115Vac	GMAW	51 Vdc	100	100A	14 Vdc
				60	140A	15,6 Vdc
				40	160A	16,4 Vdc
		FCAW-SS		100	75A	17,7 Vdc
				60	87A	18,3 Vdc
				40	100A	19 Vdc
		SMAW		100	75A	17,7 Vdc
				60	87A	18,3 Vdc
				40	100A	19 Vdc
SMAW	100	60A	22,4 Vdc			
	60	70A	22,8 Vdc			
	40	80A	23,2 Vdc			

210MP	115Vac	GTAW	51 Vdc	100	90A	13,6 Vdc
				60	110A	14,4 Vdc
				40	125A	15 Vdc
WELDING CURRENT RANGE						
	GMAW		FCAW-SS	SMAW	GTAW	
185MP	20A – 200A		20A –200A	20 – 160A	-	
210MP	230Vac	20A – 200A	20A – 200A	20 – 160A	20A – 160A	
	115Vac	20A – 100A	20A – 100A	20 – 80A	20A – 125A	
RECOMMENDED INPUT CABLE AND FUSE SIZES						
	Fuse or Circuit Breaker Size			Power Lead		
185MP	B 16A (B 25A)**			3 Conductor, 2,5mm ²		
210MP						
DIMENSION						
	Weight		Height	Width	Length	
185MP	17,3 kg		396 mm	246 mm	527 mm	
210MP						
WIRE DIAMETER / WIRE FEED SPEED RANGE						
	WFS RANGE		Solid wires	Aluminum wires	Cored wires	
185MP	1.5 ÷ 15 m/min		0.6 ÷ 1.0	-	0.9 ÷ 1.1	
210MP	1.5 ÷ 15 m/min		0.6 ÷ 1.0	1.0	0.9 ÷ 1.1	
OTHERS						
Protection Rating		Operating Humidity (t=20°C)		Operating Temperature		Storage Temperature
IP23		≤ 95%		from -10°C to +40°C		from -25°C to 55°C

** When welding with maximum current $I_2 > 160A$ replace input plug with one $> 16A$.

ECO design information

The equipment has been designed in order to be compliant with the Directive 2009/125/EC and the Regulation 2019/1784/EU.

Efficiency and idle power consumption:

Index	Name	Efficiency when max power consumption / Idle power consumption	Equivalent model
W000403577	PRESTOMIG 185MP	81,6% / 42W	No equivalent model
W000403576	PRESTOMIG 210MP	80,7% / 47W	No equivalent model

Idle state occurs under the condition specified in below table

IDLE STATE	
Condition	Presence
MIG mode	X
TIG mode	
STICK mode	
After 30 minutes of non-working	
Fan off	

The value of efficiency and consumption in idle state have been measured by method and conditions defined in the product standard EN 60974-1:20XX.

Manufacturer's name, product name, code number, product number, serial number and date of production can be read from rating plate.

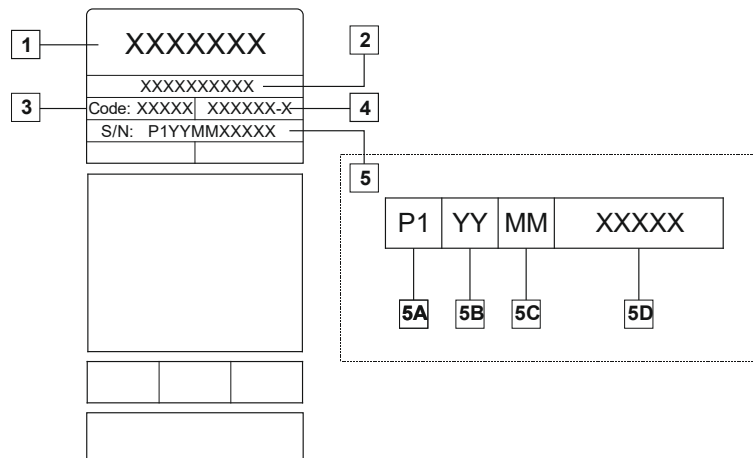

Where:

- 1- Manufacturer name and address
- 2- Product name
- 3- Code number
- 4- Product number
- 5- Serial number
 - 5A- country of production
 - 5B- year of production
 - 5C- month of production
 - 5D- progressive number different for each machine

Typical gas usage for **MIG/MAG** equipment:

Material type	Wire diameter [mm]	DC electrode positive		Wire Feeding [m/min]	Shielding Gas	Gas flow [l/min]
		Current [A]	Voltage [V]			
Carbon, low alloy steel	0,9 ÷ 1,1	95 ÷ 200	18 ÷ 22	3,5 – 6,5	Ar 75%, CO ₂ 25%	12
Aluminium	0,8 ÷ 1,6	90 ÷ 240	18 ÷ 26	5,5 – 9,5	Argon	14 ÷ 19
Austenitic stainless steel	0,8 ÷ 1,6	85 ÷ 300	21 ÷ 28	3 - 7	Ar 98%, O ₂ 2% / He 90%, Ar 7,5% CO ₂ 2,5%	14 ÷ 16
Copper alloy	0,9 ÷ 1,6	175 ÷ 385	23 ÷ 26	6 - 11	Argon	12 ÷ 16
Magnesium	1,6 ÷ 2,4	70 ÷ 335	16 ÷ 26	4 - 15	Argon	24 ÷ 28

Tig Process:

In TIG welding process, gas usage depends on cross-sectional area of the nozzle. For commonly used torches:

Helium: 14-24 l/min.

Argon: 7-16 l/min.

Notice: Excessive flow rates causes turbulence in the gas stream which may aspirate atmospheric contamination into the welding pool.

Notice: A cross wind or draft moving can disrupt the shielding gas coverage, in the interest of saving of protective gas use screen to block air flow.



End of life

At end of life of product, it has to be disposal for recycling in accordance with Directive 2012/19/EU (WEEE), information about the dismantling of product and Critical Raw Material (CRM) present in the product, can be found at <https://www.lincolnelectric.com/en-gb/support/Pages/operator-manuals-eu.aspx>.

Electromagnetic Compatibility (EMC)

11/04

This machine has been designed in accordance with all relevant directives and standards. However, it may still generate electromagnetic disturbances that can affect other systems like telecommunications (telephone, radio, and television) or other safety systems. These disturbances can cause safety problems in the affected systems. Read and understand this section to eliminate or reduce the amount of electromagnetic disturbance generated by this machine.



This machine has been designed to operate in an industrial area. To operate in a domestic area it is necessary to observe particular precautions to eliminate possible electromagnetic disturbances. The operator must install and operate this equipment as described in this manual. If any electromagnetic disturbances are detected the operator must put in place corrective actions to eliminate these disturbances with, if necessary, assistance from

Lincoln Electric.

Before installing the machine, the operator must check the work area for any devices that may malfunction because of electromagnetic disturbances. Consider the following.

- Input and output cables, control cables, and telephone cables that are in or adjacent to the work area and the machine.
- Radio and/or television transmitters and receivers. Computers or computer controlled equipment.
- Safety and control equipment for industrial processes. Equipment for calibration and measurement.
- Personal medical devices like pacemakers and hearing aids.
- Check the electromagnetic immunity for equipment operating in or near the work area. The operator must be sure that all equipment in the area is compatible. This may require additional protection measures.
- The dimensions of the work area to consider will depend on the construction of the area and other activities that are taking place.

Consider the following guidelines to reduce electromagnetic emissions from the machine.

- Connect the machine to the input supply according to this manual. If disturbances occur it may be necessary to take additional precautions such as filtering the input supply.
- The output cables should be kept as short as possible and should be positioned together. If possible connect the work piece to ground in order to reduce the electromagnetic emissions. The operator must check that connecting the work piece to ground does not cause problems or unsafe operating conditions for personnel and equipment.
- Shielding of cables in the work area can reduce electromagnetic emissions. This may be necessary for special applications.

WARNING

The Class A equipment is not intended for use in residential locations where the electrical power is provided by the public low-voltage supply system. There may be potential difficulties in ensuring electromagnetic compatibility in those locations, due to conducted as well as radiated disturbances.



WARNING

While a high electromagnetic field occurs, a welding current can fluctuate.







WARNING





This equipment complies with IEC 61000-3-12.



WARNING

This equipment must be used by qualified personnel. Be sure that all installation, operation, maintenance and repair procedures are performed only by qualified person. Read and understand this manual before operating this equipment. Failure to follow the instructions in this manual could cause serious personal injury, loss of life, or damage to this equipment. Read and understand the following explanations of the warning symbols. Lincoln Electric is not responsible for damages caused by improper installation, improper care or abnormal operation.

	<p>WARNING: This symbol indicates that instructions must be followed to avoid serious personal injury, loss of life, or damage to this equipment. Protect yourself and others from possible serious injury or death.</p>
	<p>READ AND UNDERSTAND INSTRUCTIONS: Read and understand this manual before operating this equipment. Arc welding can be hazardous. Failure to follow the instructions in this manual could cause serious personal injury, loss of life, or damage to this equipment.</p>
	<p>ELECTRIC SHOCK CAN KILL: Welding equipment generates high voltages. Do not touch the electrode, work clamp, or connected work pieces when this equipment is on. Insulate yourself from the electrode, work clamp and connected work pieces.</p>
	<p>ELECTRICALLY POWERED EQUIPMENT: Turn off input power using the disconnect switch at the fuse box before working on this equipment. Ground this equipment in accordance with local electrical regulations.</p>
	<p>ELECTRICALLY POWERED EQUIPMENT: Regularly inspect the input, electrode, and work clamp cables. If any insulation damage exists replace the cable immediately. Do not place the electrode holder directly on the welding table or any other surface in contact with the work clamp to avoid the risk of accidental arc ignition.</p>
	<p>ELECTRIC AND MAGNETIC FIELDS MAY BE DANGEROUS: Electric current flowing through any conductor creates electric and magnetic fields (EMF). EMF fields may interfere with some pacemakers and welders having a pacemaker shall consult their physician before operating this equipment.</p>
	<p>CE COMPLIANCE: This equipment complies with the European Community Directives.</p>
	<p>ARTIFICIAL OPTICAL RADIATION: According with the requirements in 2006/25/EC Directive and EN 12198 Standard, the equipment is a category 2. It makes mandatory the adoption of Personal Protective Equipment (PPE) having filter with a protection degree up to a maximum of 15, as required by EN169 Standard.</p>
	<p>FUMES AND GASES CAN BE DANGEROUS: Welding may produce fumes and gases hazardous to health. Avoid breathing these fumes and gases. To avoid these dangers the operator must use enough ventilation or exhaust to keep fumes and gases away from the breathing zone.</p>
	<p>ARC RAYS CAN BURN: Use a shield with the proper filter and cover plates to protect your eyes from sparks and the rays of the arc when welding or observing. Use suitable clothing made from durable flame-resistant material to protect you skin and that of your helpers. Protect other nearby personnel with suitable, non-flammable screening and warn them not to watch the arc nor expose themselves to the arc.</p>

	<p>WELDING SPARKS CAN CAUSE FIRE OR EXPLOSION: Remove fire hazards from the welding area and have a fire extinguisher readily available. Welding sparks and hot materials from the welding process can easily go through small cracks and openings to adjacent areas. Do not weld on any tanks, drums, containers, or material until the proper steps have been taken to insure that no flammable or toxic vapors will be present. Never operate this equipment when flammable gases, vapors or liquid combustibles are present.</p>
	<p>WELDED MATERIALS CAN BURN: Welding generates a large amount of heat. Hot surfaces and materials in work area can cause serious burns. Use gloves and pliers when touching or moving materials in the work area.</p>
	<p>CYLINDER MAY EXPLODE IF DAMAGED: Use only compressed gas cylinders containing the correct shielding gas for the process used and properly operating regulators designed for the gas and pressure used. Always keep cylinders in an upright position securely chained to a fixed support. Do not move or transport gas cylinders with the protection cap removed. Do not allow the electrode, electrode holder, work clamp or any other electrically live part to touch a gas cylinder. Gas cylinders must be located away from areas where they may be subjected to physical damage or the welding process including sparks and heat sources.</p>
	<p>SAFETY MARK: This equipment is suitable for supplying power for welding operations carried out in an environment with increased hazard of electric shock.</p>

The manufacturer reserves the right to make changes and/or improvements in design without upgrade at the same time the operator's manual.

Introduction

The welding machines **PRESTOMIG 185MP** enables welding:

- GMAW (MIG/MAG)
- FCAW-SS
- SMAW (MMA).

The welding machines **PRESTOMIG 210MP** enables welding:

- GMAW (MIG/MAG)
- FCAW-SS
- SMAW (MMA)
- GTAW (arc ignition using lift TIG).

The following equipment has been added to **PRESTOMIG 185MP** and **PRESTOMIG 210MP**:

- Work lead – 3m
- Gas hose – 2m
- Driving roll V0.8/V1.0 for solid wire (mounted in the wire feeder).

For GMAW and FCAW-SS process, the technical specification describes:

- Type of welding wire
- Wire diameter

Recommended equipment, which can be bought by user, was mentioned in the chapter "Accessories".

Installation and Operator Instructions

Read this entire section before installation or operation of the machine.

Location and Environment

This machine will operate in harsh environments. However, it is important that simple preventative measures are followed to assure long life and reliable operation:

- Do not place or operate this machine on a surface with an incline greater than 15° from horizontal.
- Do not use this machine for pipe thawing.
- This machine must be located where there is free circulation of clean air without restrictions for air movement to and from the air vents. Do not cover the machine with paper, cloth or rags when switched on.
- Dirt and dust that can be drawn into the machine should be kept to a minimum.
- This machine has a protection rating of IP23. Keep it dry when possible and do not place it on wet ground or in puddles.
- Locate the machine away from radio controlled machinery. Normal operation may adversely affect the operation of nearby radio controlled machinery, which may result in injury or equipment damage. Read the section on electromagnetic compatibility in this manual.
- Do not operate in areas with an ambient temperature greater than 40°C.

Duty cycle and Overheating

The duty cycle of a welding machine is the percentage of time in a 10 minute cycle at which the welder can operate the machine at rated welding current.

Example: 60% duty cycle

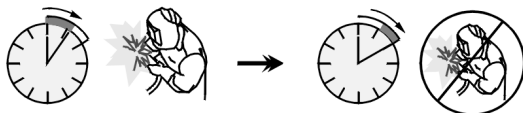

Welding for 6 minutes.

Break for 4 minutes.

Excessive extension of the duty cycle will cause the thermal protection circuit to activate.

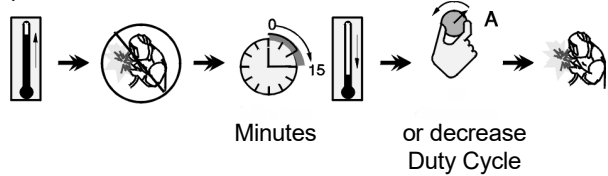

The machine is protected from overheating by a temperature sensor.

Input Supply Connection



WARNING

Only a qualified electrician can connect the welding machine to the supply network. Installation had to be made in accordance with the appropriate National Electrical Code and local regulations.

Check the input voltage, phase and frequency supplied to this machine before turning it on. Verify the connection of ground wires from the machine to the input source. The welding machine **PRESTOMIG 185MP**, **PRESTOMIG 210MP** must be connected to a correctly installed plug-in socket with an earth pin.

Input voltage is 230V, 50/60Hz. For more information about input supply refer to the technical specification section of this manual and to the rating plate of the machine.

Make sure that the amount of mains power available from the input supply is adequate for normal operation of the machine. The necessary delayed fuse (or circuit breaker with "B" characteristic) and cable sizes are indicated in the technical specification section of this manual.



WARNING

The welding machine can be supplied from a power generator of output power at least 30% larger than input power of the welding machine.



WARNING

When powering welder from a generator be sure to turn off welder first, before generator is shut down, in order to prevent damage to welder!

Output Connections

Refer to points [7], [8] and [9] of the Figures below.

Controls and Operational Features

1. LED Indicator Power switch (only PRESTOMIG 185MP): This LED lights up when the welding machine is ON and is ready to work. 

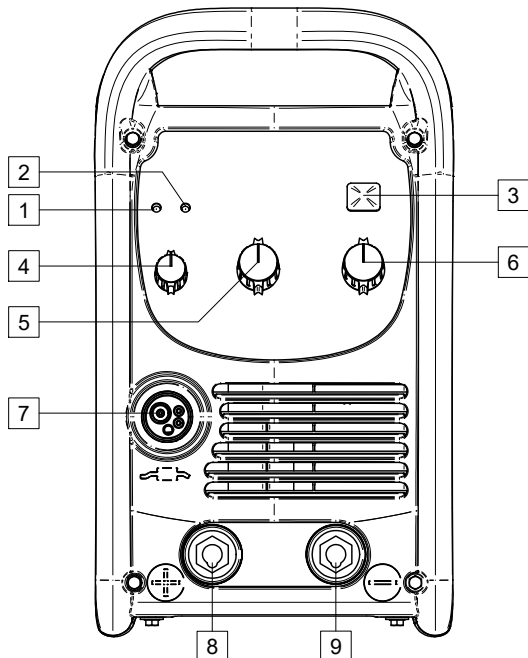
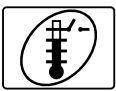





Figure 1

2. Thermal Overload Indicator: It indicates that the machine is overloaded or that the cooling is not sufficient. Depending on:

	PRESTOMIG 185MP: Overload or insufficient is shown by lighting LED under the symbol.
	PRESTOMIG 210MP: The message as image is shown by the display [13].

3. Process Welding's Switch:

	GMAW (MIG/MAG) process Warning: Can be used to FCAW-SS process.
	SMAW (MMA) process

WARNING

When the machine is switched again on, last welding process will be recalled.



WARNING

If the push-button is pushed in GMAW process in, the output terminals will lived.



WARNING

During SMAW process, the output terminals are still lived.

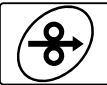

4. Knob Control: Depending on welding process, this knob controls:

GMAW process		Inductance: Arc control is controlled by this knob. If the value is higher, the arc will be softer and during welding is less spatters.
SMAW process		ARC FORCE: The output current is temporarily increased to clear short circuit connections between the electrode and the workpiece.

5. WFS/Hot Start Control: Depending on welding process, this knob controls:

GMAW process		Wire feed speed WFS: Value in percentage of nominal value wire feed speed.
SMAW process		HOT START: Value in percentage of nominal value welding current during arc start current. The control is used to set the level of the increased current and arc start current is made easy.

6. Welding Load Voltage / Current Knob Control: Depending on welding process, this knob controls:

GMAW process		The welding load voltage and set by this knob [6] (also during welding).
SMAW process		The welding current is set by this knob [6] (also during welding).

7. EURO Socket: For connecting a welding gun (for GMAW / FCAW-SS process).

8. Positive Output Socket for the Welding Circuit: For connecting an electrode holder with lead / work lead. 

9. Negative Output Socket for the Welding Circuit: For connecting an electrode holder with lead / work lead. 

10. Left Knob: The value of parameter in the upper left side of display [13] is adjusted.

11. Right Knob: The value of parameter in the upper right side of display [13] is adjusted.

12. Set Knob: Type of welding procedure and welding settings is changed by this knob.

13. Display: Parameters of welding process are shown.

14. User Button (left): Button function could be set:

- Advanced menu:
 - Recalls advanced menu (default)
 - Recalls user memory.
 - Inductance.
 - Run-in WFS.
 - Burnback.
- Basic menu – changes basic menu for advanced menu.

15. Escape Button (right):

- Cancels an action / exit menu.
- Locks and unlocks knobs and buttons on the panel (press and hold button for 4 seconds).

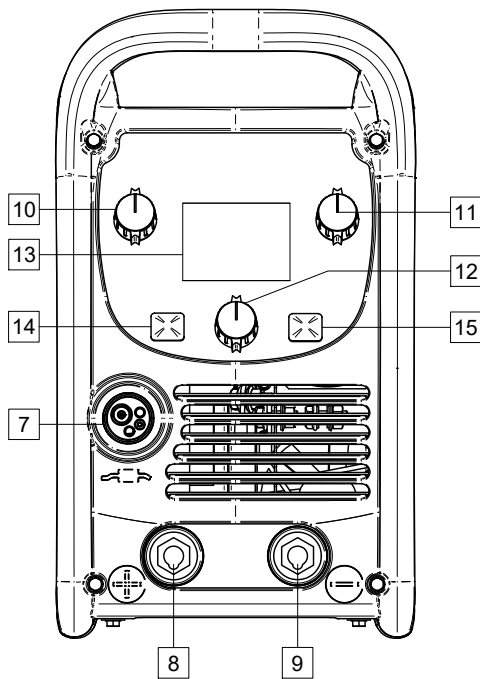

Figure 2

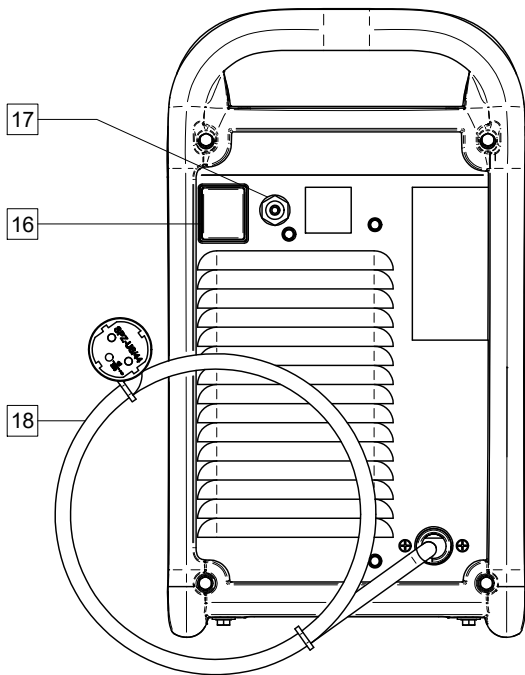

Figure 3

16. Power Switch ON/OFF (I/O): Controls the input power to the machine. Be sure the power source is connected to the mains supply before turning power on ("I"). After input power is connected and the power switch is turned on, the indicator will light up to indicate the machine is ready to weld.

17. Gas Connector: Connection for gas line.



18. Power Lead with Plug (2m): Power lead with plug is a standard equipment. Connect the power lead with plug to the main supply before turning power on.

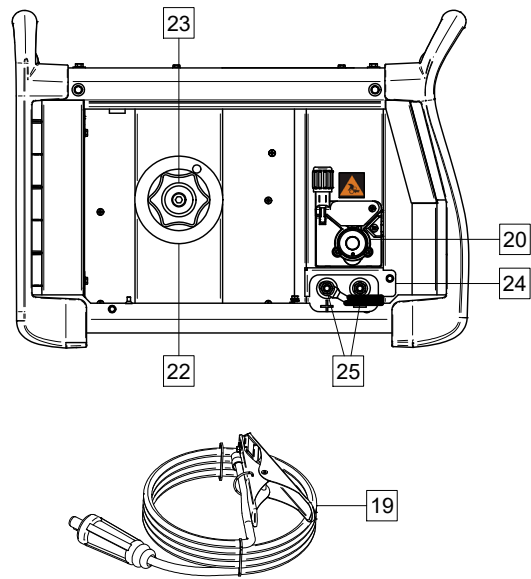

Figure 4

19. Work Lead.

20. Wire Drive (for GMAW, FCAW-SS process): 2-Roll wire drive.

21. Welding Wire (for GMAW / FCAW-SS).

22. Spooled Wire (for GMAW / FCAW-SS): The machine does not include a spooled wire.

23. Wire Spool Support: Maximum 5kg spools. Accepts plastic, steel and fiber spools onto 51mm spindle.

24. Shield of Changing Polarity.

25. Terminal Block of Changing Polarity (for GMAW / FCAW-SS process): This terminal block enables to set the welding polarity (+ ; -), which will be given at the welding holder.

! WARNING

Positive (+) polarity is set at the factory.

! WARNING

Before welding check the polarity for using electrodes and wires.

If the welding polarity has to be changed, user should:

- Switch off the machine.
- Determine the wire polarity for the wire to be used. Consult the electrode data for this information.
- Take off the terminal block's shield [24].
- The tip of the wire on the terminal block [25] and work lead fix as is shown in the Table 1 or the Table 2.
- Put on the terminal block's shield.

! WARNING

The machine must be used with the door completely closed during welding.

! WARNING

Not use handle to move the machine during work.

Table 1

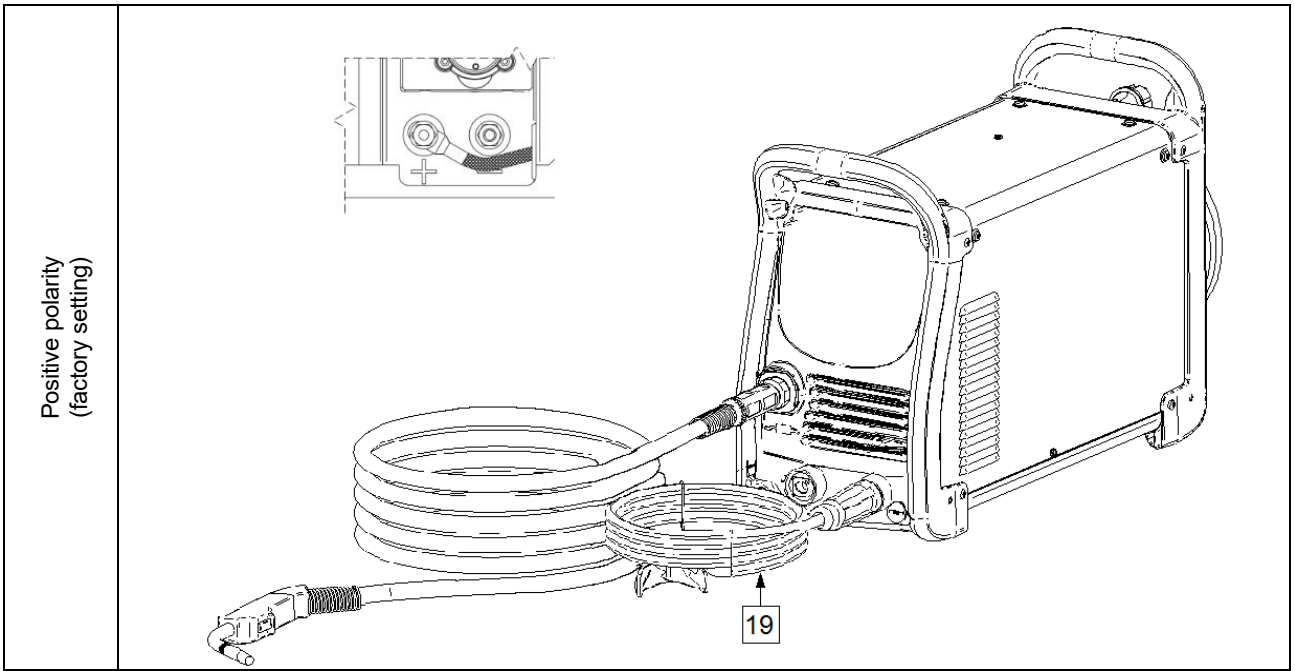
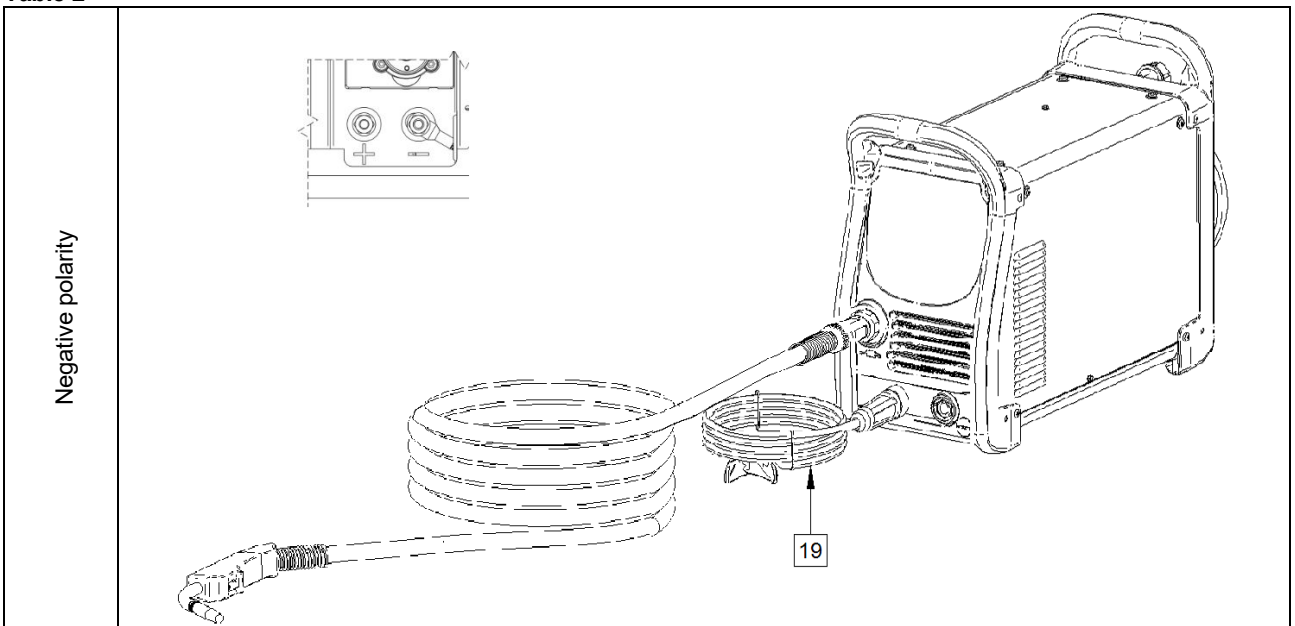

Table 2



Loading the Electrode Wire

- Turn the machine off.
- Open the side cover of the machine.
- Unscrew the locking nut of the sleeve.
- Load the spool with the wire [22] on the sleeve such that the spool turns anticlockwise when the wire [21] is fed into the wire feeder.
- Make sure that the spool locating pin goes into the fitting hole on the spool.
- Screw in the fastening cap of the sleeve.
- Put on the wire roll using the correct groove corresponding to the wire diameter.
- Free the end of the wire and cut off the bent end making sure it has no burr.

WARNING

Sharp end of the wire can hurt.

- Rotate the wire spool anticlockwise and thread the end of the wire into the wire feeder as far as the Euro socket.
- Adjust force of pressure roll of the wire feeder properly.

Adjustments of Brake Torque of Sleeve

To avoid spontaneous unrolling of the welding wire the sleeve is fitted with a brake.

Adjustment is carried by rotation of its Allen screw M8, which is placed inside of the sleeve frame after unscrewing the fastening cap of the sleeve.

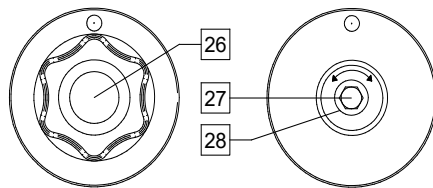

Figure 5

- 26. Fastening cap.
- 27. Adjusting Allen screw M8.
- 28. Pressing spring.

Turning the Allen screw M8 clockwise increases the spring tension and you can increase the brake torque.

Turning the Allen screw M8 anticlockwise decreases the spring tension and you can decrease the brake torque.

After finishing of adjustment, you should screw in the fastening cap again.

Adjusting of Force of Pressure Roll Force

The pressure arm controls the amount of force the drive rolls exert on the wire.

Pressure force is adjusted by turning the adjustment nut clockwise to increase force, counterclockwise to decrease force. Proper adjustment of pressure arm gives the best welding performance.

WARNING

If the roll pressure is too low the roll will slide on the wire. If the roll pressure is set too high the wire may be deformed, which will cause feeding problems in the welding gun. The pressure force should be set properly. Decrease the pressure force slowly until the wire just begins to slide on the drive roll and then increase the force slightly by turning of the adjustment nut by one turn.

Inserting Electrode Wire into Welding Torch

- Turn the welding machine off.
- Depending on welding process, connect the proper gun to the euro socket, the rated parameters of the gun and of the welding machine should be matched.
- Remote the nozzle from the gun and contact tip or protection cap and contact tip. Next, straighten the gun out flat.
- Turn the welding machine on.
- Depress the gun trigger to feed the wire through the gun liner until the wire comes out of the threaded end.
- When trigger is released spool of wire should not unwind.
- Adjust wire spool brake accordingly.
- Turn the welding machine off.
- Install a proper contact tip.
- Depending on the welding process and the type of the gun, install the nozzle (GMAW process) or protection cap (FCAW-SS process).

WARNING

Take precaution to keep eyes and hands away from the end of the gun while the wire is being come out of the threaded end.

Changing Driving Rolls

WARNING

Turn the input power off of the welding power source before installation or changing drive rolls.

PRESTOMIG 185MP and **PRESTOMIG 210MP** is equipped with drive roll V0.8/V1.0 for steel wire. For others wire sizes, is available the proper drive rolls kit (see "Accessories" chapter) and follow instructions:

- Turn the welding machine off.
- Release the pressure roll lever [30].
- Unscrew the fastening cap [29].
- Change the drive rolls [31] with the compatible ones corresponding to the used wire.

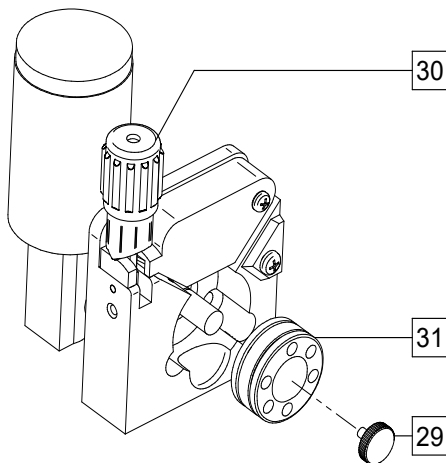

Figure 6

- Screw fastening cap [29].

Gas Connection

A gas cylinder must be installed with a proper flow regulator. Once a gas cylinder with a flow regulator has been securely installed, connect the gas hose from the regulator to the machine gas inlet connector. Refer to point [17] of the Figure 3.

WARNING

The welding machine supports all suitable shielding gases including carbon dioxide, argon and helium at a maximum pressure of 5,0 bars.

Welding GMAW, FCAW-SS Process

PRESTOMIG 185MP and **PRESTOMIG 210MP** can be used to welding GMAW and FCAW-SS process.

PRESTOMIG 210MP has been provided with synergic GMAW process.

PRESTOMIG 185MP and **PRESTOMIG 210MP** does not include the gun necessary for GMAW or FCAW-SS welding. Depending on the welding process can be purchased separately (see "Accessories" chapter).

Preparation the Machine for Welding GMAW and FCAW-SS Process

Procedure of begin welding of GMAW or FCAW-SS process:

- Determine the wire polarity for the wire to be used. Consult the wire data for this information.
- Connect output the gas-cooled gun to GMAW / FCAW-SS process to Euro Socket [7].
- Depending on the using wire, connect the work lead [19] to output socket [8] or [9]. See [25] point – terminal block of changing polarity.
- Connect the work lead to the welding piece with the work clamp.
- Install the proper wire.
- Install the proper drive roll.
- Make a sure, if it is needed (GMAW process), that the gas shield has been connected.
- Turn the machine on.
- Push the gun trigger to feed the wire through the gun liner until the wire comes out of the threaded end.
- Install a proper contact tip.
- Depending on the welding process and the type of the gun, install the nozzle (GMAW process) or protection cap (FCAW-SS process).
- Close the left side panel.
- The welding machine is now ready to weld.
- By applying the principle of occupational health and safety at welding, welding can be begun.

Welding GMAW, FCAW-SS Process in Manual Mode

Depending on welding machine, in manual mode can be set:

PRESTOMIG 185MP	
<ul style="list-style-type: none"> • The welding load voltage • WFS • Inductance 	
PRESTOMIG 210MP	
Basic menu	Advanced menu
<ul style="list-style-type: none"> • The welding load voltage • WFS • 2-Step / 4-Step 	<ul style="list-style-type: none"> • The welding load voltage • WFS • Burnback • Run-in WFS • Spot Time • Preflow Time/ Pastflow Time • 2-Step/4-Step • Inductance

The 2-Step - 4-Step changes the function of the gun's trigger.

- 2 Step trigger operation turns welding on and off in direct response to the trigger. Welding process is performed when the gun's trigger is pulled.
- 4-Step mode allows to continue welding, when the gun's trigger is released. To stop welding, the gun's trigger is pulled again. 4-step mode facilitates to making long welds.

WARNING

4-Step does not work during Spot Welding.

The Burnback Time is the amount of time that the weld output continues after the wire stops feeding. It prevents the wire from sticking in the puddle and prepares the end of the wire for the next arc start.

Run-in WFS sets the wire feed speed from the time the trigger is pulled until an arc is established.

Spot Timer adjusts the time welding will continue even if the trigger is still pulled. This option has no effect in 4-Step Trigger Mode.

 **WARNING**

Spot Timer has no effect in 4-Step Trigger Mode.

Preflow Time adjusts the time that shielding gas flows after the trigger is pulled and prior to feeding.

Postflow Time adjusts the time that shielding gas flows after the welding output turns off.

Welding GMAW in Synergic Mode (PRESTOMIG 210MP only)

In synergic mode, the welding load voltage is not set by user. The correct welding load voltage will set by the machine's software. This value was recalled on the basis of data (input data) had been loaded:

PRESTOMIG 210MP	
Basic menu	Advanced menu
<ul style="list-style-type: none"> Wire type (material) Wire diameter Gas 	<ul style="list-style-type: none"> Wire type (material) Wire diameter Gas

The welding load voltage can be changed depend on the value of parameters are set by operators:

PRESTOMIG 210MP	
Basic menu	Advanced menu
<ul style="list-style-type: none"> WFS Welding current Material thickness 	<ul style="list-style-type: none"> WFS Welding current Material thickness

If it is needed, the welding load voltage can be adjusted $\pm 2V$ by the right knob [11].
Additionally, user can manually set:

PRESTOMIG 210MP	
Basic menu	Advanced menu
No possibilities	<ul style="list-style-type: none"> Burnback Run-in WFS Spot Timer Preflow Time / Postflow Time 2-STEP/4-STEP Inductance

The 2-Step - 4-Step changes the function of the gun's trigger.

- 2 Step trigger operation turns welding on and off in direct response to the trigger. Welding process is performed when the gun's trigger is pulled.
- 4-Step mode allows to continue welding, when the gun's trigger is released. To stop welding, the gun's trigger is pulled again. 4-step mode facilitates to making long welds.

 **WARNING**

4-Step does not work during Spot Welding.

The Burnback Time is the amount of time that the weld output continues after the wire stops feeding. It prevents the wire from sticking in the puddle and prepares the end of the wire for the next arc start.

Run-in WFS sets the wire feed speed from the time the trigger is pulled until an arc is established.

Spot Timer adjusts the time welding will continue even if the trigger is still pulled. This option has no effect in 4-Step Trigger Mode. Adjusting range:

 **WARNING**

Spot Timer has no effect in 4-Step Trigger Mode.

Preflow Time adjusts the time that shielding gas flows after the trigger is pulled and prior to feeding.

Postflow Time adjusts the time that shielding gas flows after the welding output turns off.

Welding SMAW (MMA) Process

PRESTOMIG 185MP and **PRESTOMIG 210MP** does not include the electrode holder with lead necessary for SMAW welding, but the one can be purchased separately.

Procedure of begin welding of SMAW process:

- First turn the machine off.
- Determine the electrode polarity for the electrode to be used. Consult the electrode data for this information.
- Depending on the polarity of using electrode, connect the work lead [19] and the electrode holder with lead to output socket [8] or [9] and lock them. See the Table 3.

Table 3

		Output socket		
POLARITY	DC (+)	The electrode holder with lead to SMAW	[8]	+
		Work lead	[9]	-
	DC (-)	The electrode holder with lead to SMAW	[9]	-
		Work lead	[8]	+

- Connect the work lead to the welding piece with the work clamp.
- Install the proper electrode in the electrode holder.
- Turn the welding machine on.
- Set the welding parameters.
- The welding machine is now ready to weld.
- By applying the principle of occupational health and safety at welding, welding can be begun.

Depending on welding machine, the user can set functions:

PRESTOMIG 185MP	
<ul style="list-style-type: none"> • The welding current • HOT START • ARC FORCE 	
PRESTOMIG 210MP	
Basic menu	Advanced menu
<ul style="list-style-type: none"> • The welding current • Switch on / switch off the output voltage on the output lead 	<ul style="list-style-type: none"> • The welding current • Switch on / switch off the output voltage on the output lead • HOT START • ARC FORCE

Welding GTAW Process (PRESTOMIG 210MP only)

PRESTOMIG 210MP can be used to GTAW process with DC (-). Arc ignition can be achieved only by lift TIG method (contact ignition and lift ignition).

PRESTOMIG 210MP does not include the torch to GTAW welding, but the one can be purchased separately. See "Accessories" chapter.

Procedure of begin welding of GTAW process:

- First turn the machine off.
- Connect GTAW torch to [9] output socket.
- Connect the work lead to [8] output socket.
- Connect the work lead to the welding piece with the work clamp.
- Install the proper tungsten electrode in the GTAW torch.
- Turn the machine on.
- Set the welding parameters.
- The welding machine is now ready to weld.
- By applying the principle of occupational health and safety at welding, welding can be begun.

During welding GTAW process, the user can set function:

PRESTOMIG 210MP	
Basic menu	Advanced menu
<ul style="list-style-type: none"> • The welding current • Switch on / switch off the output voltage on the output lead 	<ul style="list-style-type: none"> • The welding current • Switch on / switch off the output voltage on the output lead

Memory – Save, Recall, Delete (PRESTOMIG 210MP only)

PRESTOMIG 210MP enables saving, recalling and deleting the parameter's settings. 9 memories can be used by user.

Saving, recalling and deleting process settings is accessible in advanced menu of **PRESTOMIG 210MP**.

Error's Message (PRESTOMIG 210MP only)

Contact with the Technical Service Center or Lincoln Electric, when a machine's display of **PRESTOMIG 210MP** will show a message of the Figure 7 or similar.

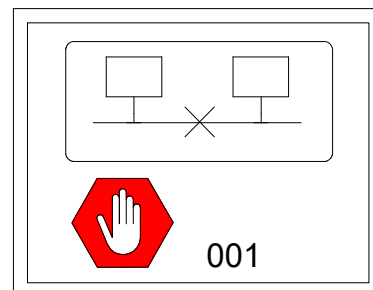

Figure 7

Guide's Marking Interface PRESTOMIG 210MP

Description of the user interface in "Quick Guide" chapter

	Select Welding Process		SMAW (MMA) Welding		Basic menu
	Burnback		GMAW (MIG/MAG) Manual Welding		Brightness Level
	Run-in WFS		FCAW- Self shielded Manual Welding		View Software and Hardware Version Information
	Prewflow Time		GMAW (MIG/MAG) Synergic Welding		User Button
	Postflow Time		Select Process by Number		Cancel an Action
	Inductance		Select Gas		Switch On Output Voltage (TIG/MMA only)
	Spot Welding Setting		Select Wire Type (material)		Switch Off Output Voltage (TIG/MMA only)
	Spot Timer		Select Wire Size (diameter)		Unlock panel
	Switch off Spot Welding		Select Function of Gun Trigger (2-Step / 4-Step)		Unlock Panel by Code
	2-Step		Configuration and Set-up		Hot Start
	4-Step		Lock / Unlock Panel		Arc Force
	Memory		Lock Panel		Adjust Voltage
	Save a Memory		Lock Panel by Code		Welding Thickness Material
	Recall a Memory (user memory)		Recall Factory Setting		Welding current
	Clear a Memory		Select Menu (basic / advanced)		Wire Feeder Speed (WFS)
	GTAW (TIG) Welding		Advanced Menu		

Maintenance

WARNING

For any repair operations, modifications or maintenances, it is recommended to contact the nearest Technical Service Center or Lincoln Electric. Repairs and modifications performed by unauthorized service or personnel will cause, that the manufacturer's warranty will become null and void.

Any noticeable damage should be reported immediately and repaired.

Routine maintenance (everyday)

- Check condition of insulation and connections of the work leads and insulation of power lead. If any insulation damage exists replace the lead immediately.
- Remove the spatters from the welding gun nozzle. Spatters could interfere with the shielding gas flow to the arc.
- Check the welding gun condition: replace it, if necessary.
- Check condition and operation of the cooling fan. Keep clean its airflow slots.

Periodic maintenance (every 200 working hours but at list once every year)

Perform the routine maintenance and, in addition:

- Keep the machine clean. Using a dry (and low pressure) airflow, remove the dust from the external case and from the cabinet inside.
- If it is required, clean and tighten all weld terminals.

The frequency of the maintenance operations may vary in accordance with the working environment where the machine is placed.

WARNING

Do not touch electrically live parts.

WARNING

Before the case of welding machine will be removed, the welding machine had to be turned off and the power lead had to be disconnected from mains socket.

WARNING

Mains supply network must be disconnected from the machine before each maintenance and service. After each repair, perform proper tests to ensure safety.

Customer Assistance Policy

The business of The Lincoln Electric Company is manufacturing and selling high quality welding equipment, consumables, and cutting equipment. Our challenge is to meet the needs of our customers and to exceed their expectations. On occasion, purchasers may ask Lincoln Electric for advice or information about their use of our products. We respond to our customers based on the best information in our possession at that time. Lincoln Electric is not in a position to warrant or guarantee such advice, and assumes no liability, with respect to such information or advice. We expressly disclaim any warranty of any kind, including any warranty of fitness for any customer's particular purpose, with respect to such information or advice. As a matter of practical consideration, we also cannot assume any responsibility for updating or correcting any such information or advice once it has been given, nor does the provision of information or advice create, expand or alter any warranty with respect to the sale of our products.

Lincoln Electric is a responsive manufacturer, but the selection and use of specific products sold by Lincoln Electric is solely within the control of, and remains the sole responsibility of the customer. Many variables beyond the control of Lincoln Electric affect the results obtained in applying these types of fabrication methods and service requirements.

Subject to Change – This information is accurate to the best of our knowledge at the time of printing. Please refer to www.saf-fro.com for any updated information.

WEEE

07/06



Do not dispose of electrical equipment together with normal waste!

In observance of European Directive 2012/19/EC on Waste Electrical and Electronic Equipment (WEEE) and its implementation in accordance with national law, electrical equipment that has reached the end of its life must be collected separately and returned to an environmentally compatible recycling facility. As the owner of the equipment, you should get information on approved collection systems from our local representative.

By applying this European Directive you will protect the environment and human health!

Spare Parts

12/05

Part list reading instructions

- Do not use this part list for a machine if its code number is not listed. Contact the Lincoln Electric Service Department for any code number not listed.
- Use the illustration of assembly page and the table below to determine where the part is located for your particular code machine.
- Use only the parts marked "X" in the column under the heading number called for in the assembly page (# indicate a change in this printing).

First, read the Part List reading instructions above then refer to the "Spare Part" manual supplied with the machine, which contains a picture-descriptive part number cross-reference).

REACH

11/19

Communication in accordance with Article 33.1 of Regulation (EC) No 1907/2006 – REACH.

Some parts inside this product contain:

Bisphenol A, BPA,	EC 201-245-8, CAS 80-05-7
Cadmium,	EC 231-152-8, CAS 7440-43-9
Lead,	EC 231-100-4, CAS 7439-92-1
Phenol, 4-nonyl-, branched,	EC 284-325-5, CAS 84852-15-3

in more than 0,1% w/w in homogeneous material. These substances are included in the "Candidate List of Substances of Very High Concern for Authorisation" of REACH.

Your particular product may contain one or more of the listed substances.

Instructions for safe use:

- use according to Manufacturer instructions, wash hands after use;
- keep out of reach of children, do not put in mouth,
- dispose in accordance with local regulations.

Authorized Service Shops Location





09/16

- The purchaser must contact Lincoln Electric or Authorized Service Facility about any defect claimed under warranty period.
- Contact your local Sales Representative for assistance in locating the nearest Authorized Service Facility.

Electrical Schematic

Refer to the "Spare Parts" manual supplied with the machine.

Accessories

	W10429-15-3M	The gas-cooled gun LGS2 150 G-3.0M to GMAW process - 3m
	W10429-24-3M	The gas-cooled gun LGS2 240 G-3.0M to GMAW process - 3m
	W10429-25-3M	The gas-cooled gun LGS2 250 G-3.0M to GMAW process - 3m
	W10529-17-4V	WTT2 17V 4M 1/4G 35-50
	E/H-200A-25-3M	Welding cable with electrode holder to SMAW process - 3m.
	W000260684	WELDLINE lead's KIT to SMAW process: <ul style="list-style-type: none"> • The electrode holder with lead to SMAW process - 3m. • Work lead - 3m.
	KIT-200A-25-3M	Lead's KIT to SMAW process: <ul style="list-style-type: none"> • The electrode holder with lead to SMAW process - 3m. • Work lead - 3m.
	KIT-200A-35-5M	Lead's KIT to SMAW process: <ul style="list-style-type: none"> • The electrode holder with lead to SMAW process - 5m. • Work lead - 5m.

Drive rolls to 2 driven rolls	
KP14016-0.8 KP14016-1.0	Solid wires: V0.6 / V0.8 V0.8 / V1.0
KP14016-1.2A	Aluminum wires: U1.0 / U1.2
KP14016-1.1R	Cored wires: VK0.9 / VK1.1