

MACHINE SCHEMATIC G6378 REV: A

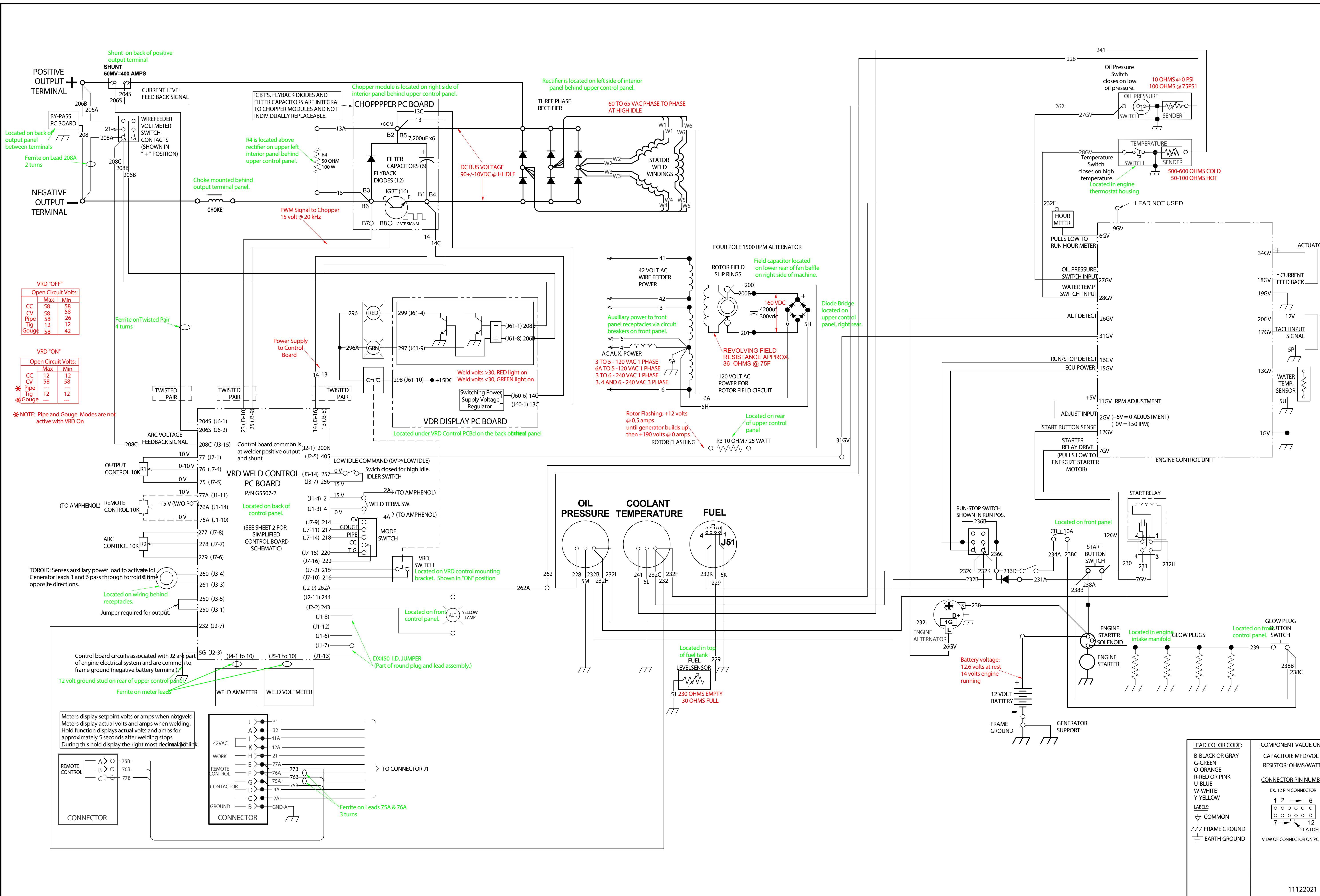

SIMPLIFIED CONTROL BOARD SCHEMATIC

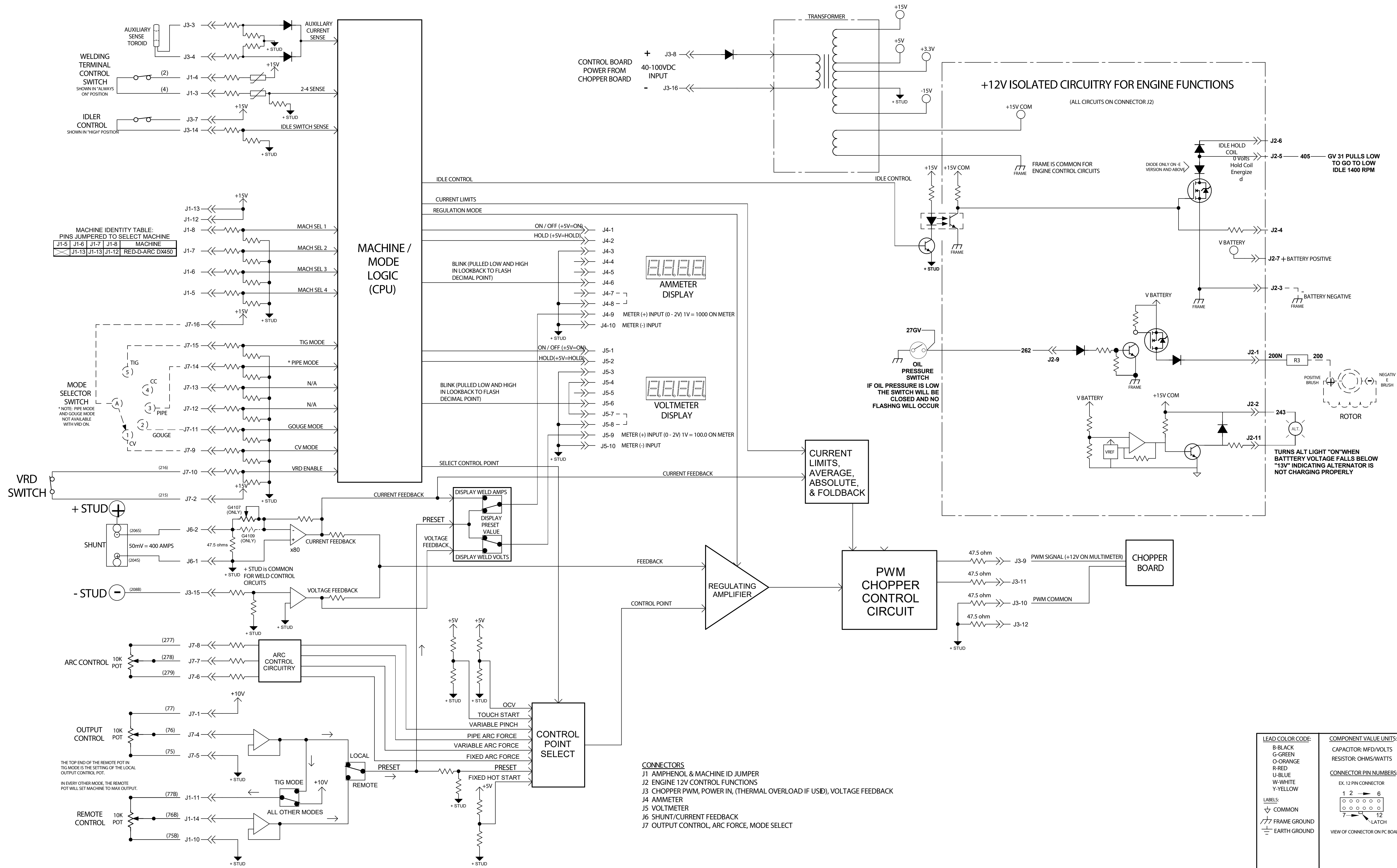

MACHINE IDENTITY TABLE:
PINS JUMPERED TO SELECT MACHINE

J1-5	J1-6	J1-7	J1-8	MACHINE
×	×	×	×	RED-D-ARC DX450

MODE SELECTOR SWITCH
*NOTE: PIPE MODE AND GOUGE MODE NOT AVAILABLE WITH VRD ON.

- CONNECTORS**
- J1 AMPHENOL & MACHINE ID JUMPER
 - J2 ENGINE 12V CONTROL FUNCTIONS
 - J3 CHOPPER PWM, POWER IN, (THERMAL OVERLOAD IF USED), VOLTAGE FEEDBACK
 - J4 AMMETER
 - J5 VOLTMETER
 - J6 SHUNT/CURRENT FEEDBACK
 - J7 OUTPUT CONTROL, ARC FORCE, MODE SELECT

LEAD COLOR CODE:

- B-BLACK
- G-GREEN
- O-ORANGE
- R-RED
- U-BLUE
- W-WHITE
- Y-YELLOW

COMPONENT VALUE UNITS:

- CAPACITOR: MFD/VOLTS
- RESISTOR: OHMS/WATTS

CONNECTOR PIN NUMBERS:

EX: 12 PIN CONNECTOR

1	2	3	4	5	6
7	8	9	10	11	12

VIEW OF CONNECTOR ON PCB BOARD