

VANTAGE 580 AU MACHINE SCHEMATIC G6924-1 REV: B

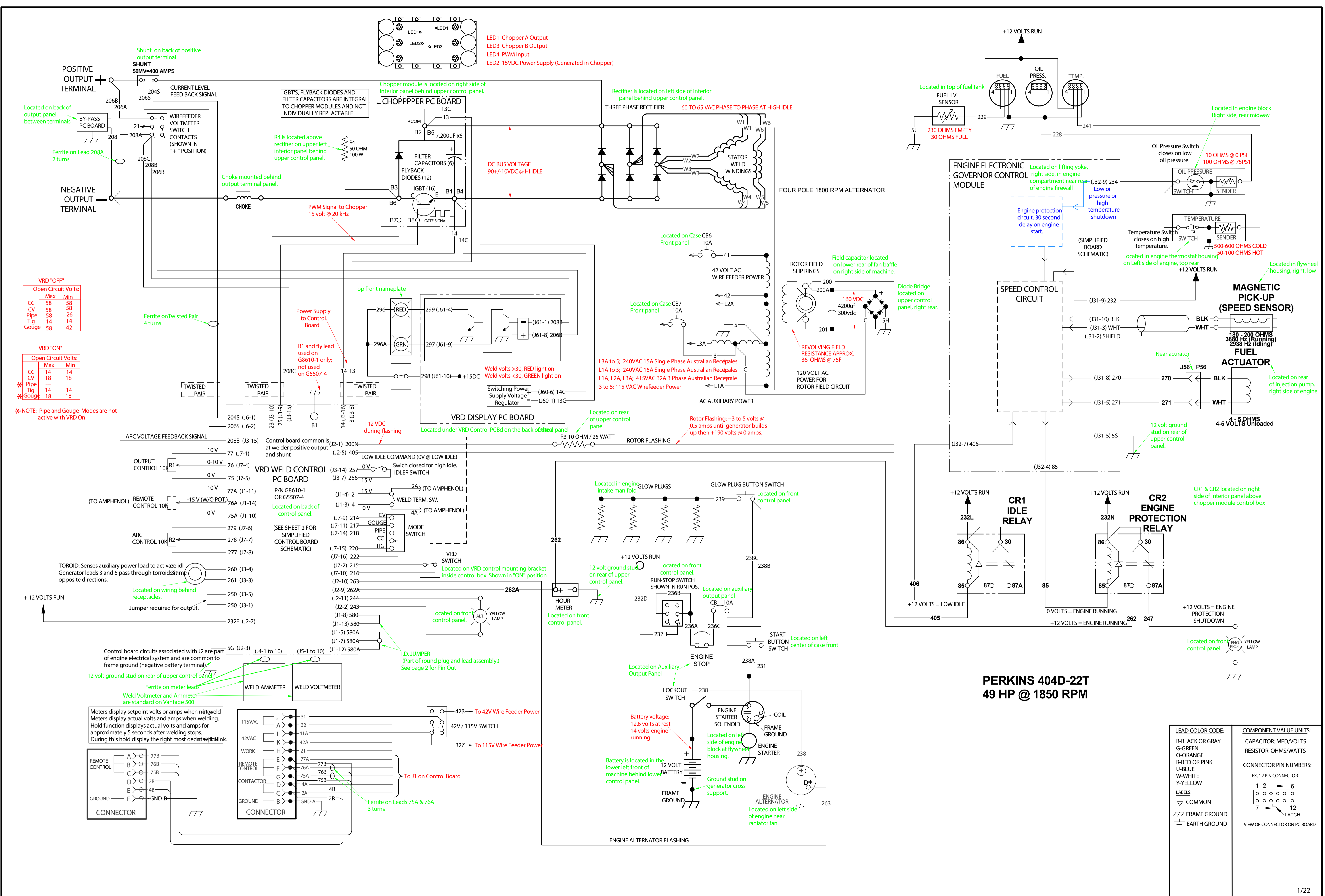

VRD "OFF"

Open Circuit Volts:	Max	Min
CC	58	58
CV	58	58
Pipe	58	26
Tig	14	14
Gouge	58	42

VRD "ON"

Open Circuit Volts:	Max	Min
CC	14	14
CV	18	18
Pipe	---	---
Tig	14	14
Gouge	18	18

* NOTE: Pipe and Gouge Modes are not active with VRD On

SIMPLIFIED CONTROL BOARD SCHEMATIC

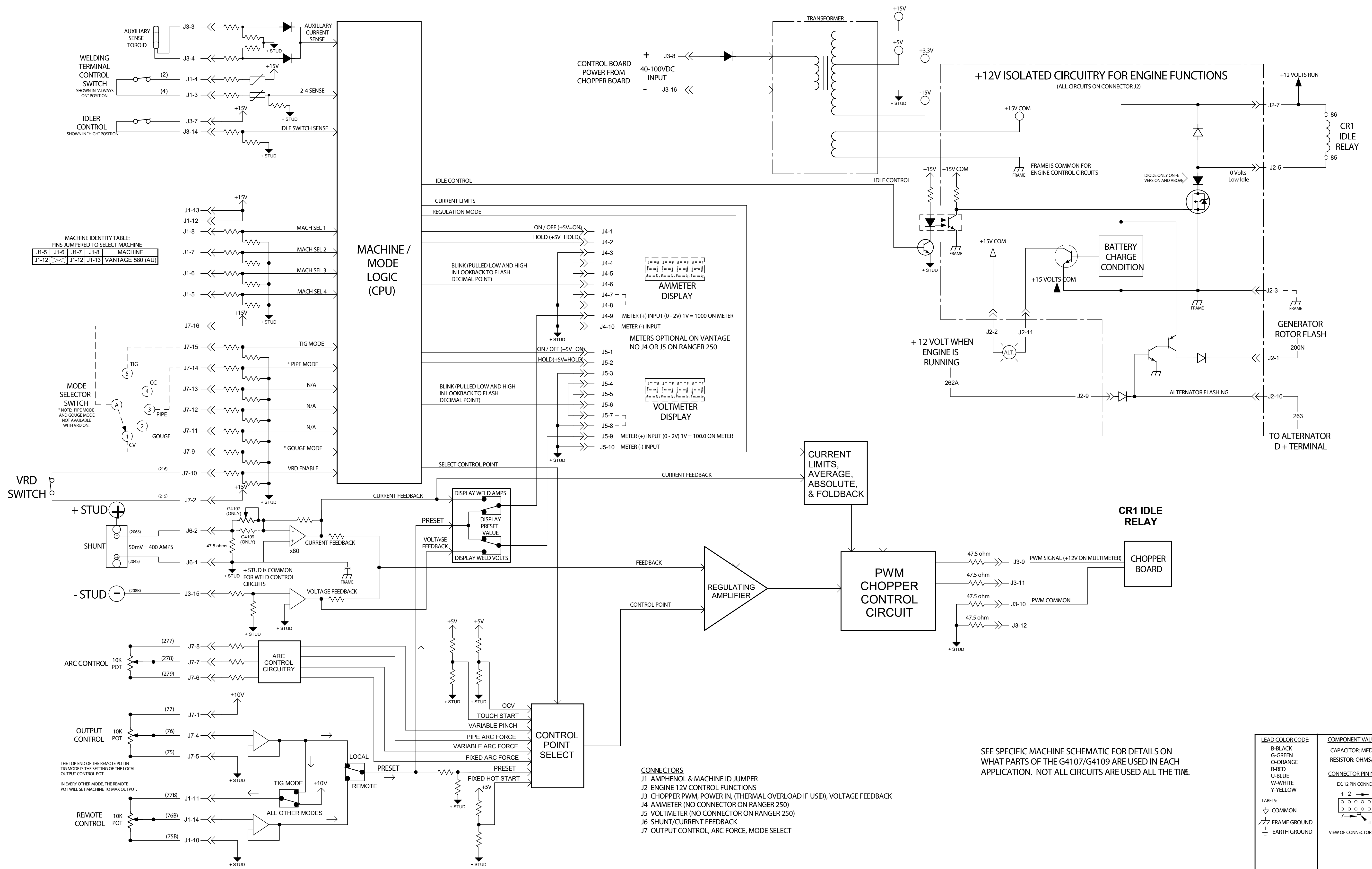

SEE SPECIFIC MACHINE SCHEMATIC FOR DETAILS ON WHAT PARTS OF THE G4107/G4109 ARE USED IN EACH APPLICATION. NOT ALL CIRCUITS ARE USED ALL THE TIME.