

141-272, 87116

**REPLACEMENT PARTS LIST
15/2/100 AMP FULLY AUTO CHARGER
MODEL 141-272**

ITEM	DESCRIPTION	PART NUMBER	ITEM	DESCRIPTION	PART NUMBER
1	AMMETER	247-130-666	6	POWER CORD	248-283-666
2	BASE	440-444-***	7	HANDLE W/ STRAIN RELIEF	412-260-666
3	RECTIFIER ASSEMBLY W/ CIRCUIT BOARD	865-775-666	8	COVER	440-247-***
4	CIRCUIT BREAKER ONLY	246-175-666	9	TRANSFORMER ASSEMBLY	865-776-888
5	DC LEAD ASSEMBLY W/ CLAMPS & STRAIN RELIEF	865-798-666	10	8-POSITION ROTARY SWITCH	246-314-666
	POSITIVE & NEGATIVE CLAMPS ONLY	249-064-666	11	CONTROL KNOB	246-041-666

NOTE: ** MUST SPECIFY COLOR
NOTE: *** MUST SPECIFY BRAND

SERVICING SHOULD BE PERFORMED BY QUALIFIED SERVICE PERSONNEL.

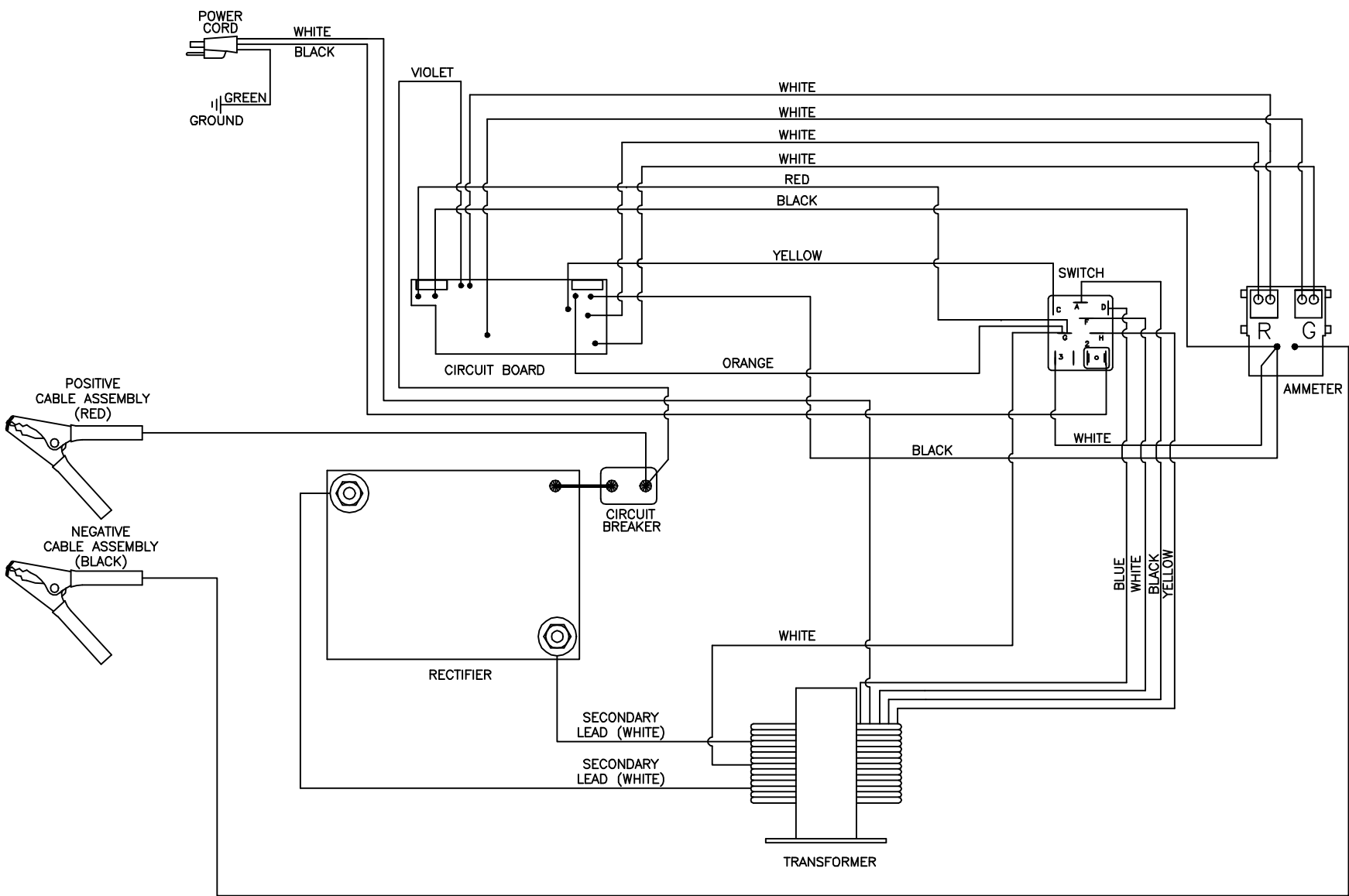

Model 141-272

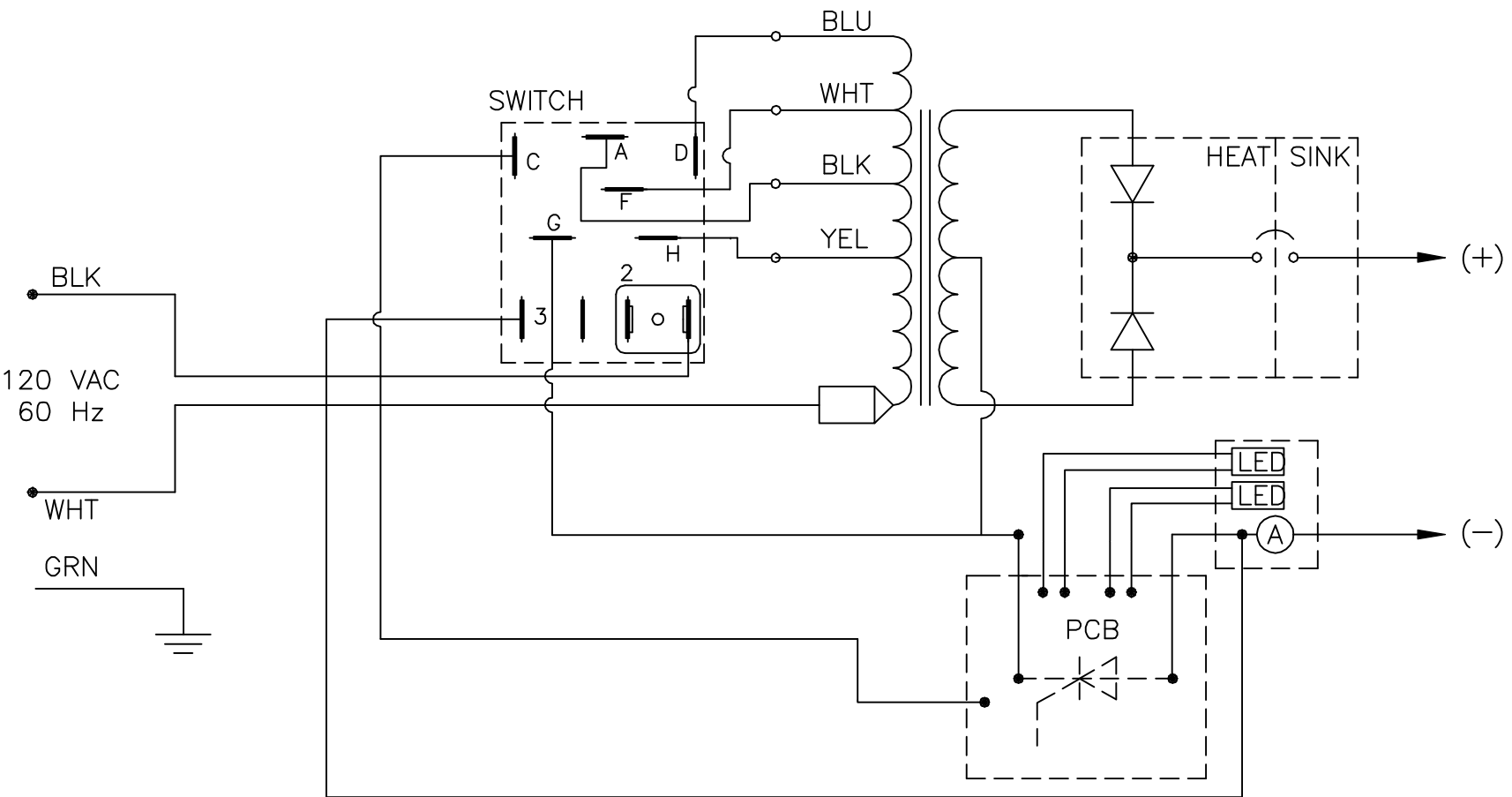

Model 141-272