

SP WELDERS WIRING DIAGRAM M20143 REV: B

CUSTOMER VOLTAGE RECONNECTION FOR DUAL VOLTAGE MACHINE

MACHINES ARE SHIPPED FROM FACTORY CONNECTED FOR 230V AS SHOWN. TO CONNECT WELDER FOR 208V INPUT, DISCONNECT WELDER FROM INPUT POWER, REMOVE CASE SIDE, REMOVE LEAD MARKED "H1" FROM CR1. REMOVE TAPE SECURING H3 TO LEAD SLEEVING AND CONNECT H3 TO CR1. INSULATE UNUSED H1 LEAD FOR 300V WITH ELECTRICAL TAPE AND SECURE TO LEAD SLEEVING. REINSTALL CASE SIDE BEFORE CONNECTING INPUT POWER. RECONNECTION TO 230V IS REVERSE OF ABOVE PROCEDURE. SEE INSTRUCTION MANUAL FOR DETAILS.

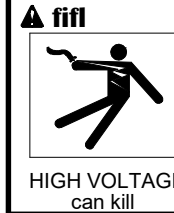

- Do not operate with covers removed.
- Disconnect input power by unplugging power cord before servicing.
- Do not touch electrically live parts
- Only qualified persons should install, use or service this machine.

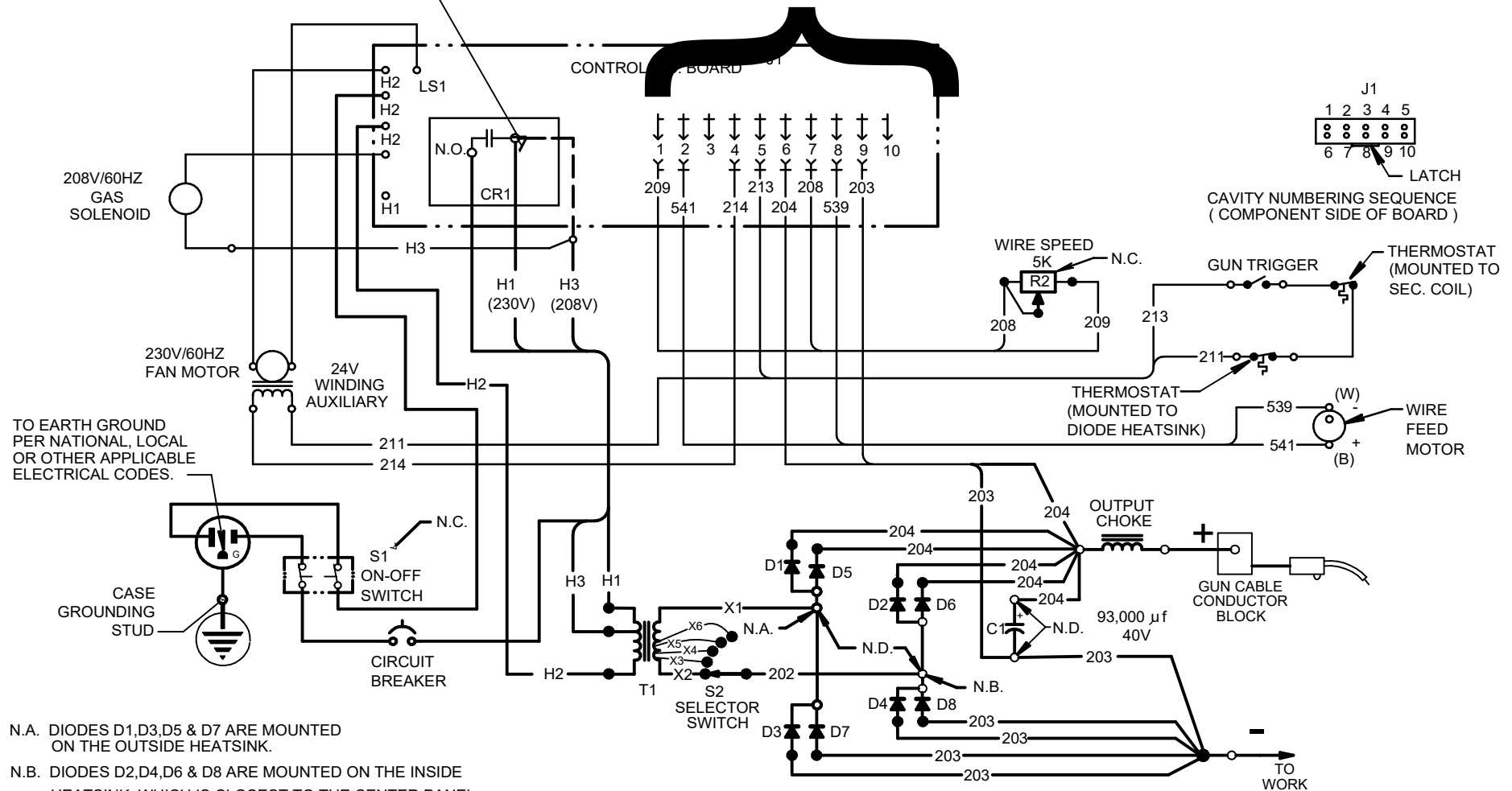

- N.A. DIODES D1,D3,D5 & D7 ARE MOUNTED ON THE OUTSIDE HEATSINK.
- N.B. DIODES D2,D4,D6 & D8 ARE MOUNTED ON THE INSIDE HEATSINK, WHICH IS CLOSEST TO THE CENTER PANEL.
- N.C. COMPONENT VIEWED FROM REAR.
- N.D. BOLTED ALUMINUM CONNECTIONS REQUIRE T12837 JOINT COMPOUND (DOW CORNING 340) WHEN REATTACHING.

LEAD COLOR CODE:
B-BLACK
W-WHITE



CLEVELAND, OHIO U.S.A.