

Operator's Manual

***Flextec[®] 350XP & Flextec[®] 350X
Construction***

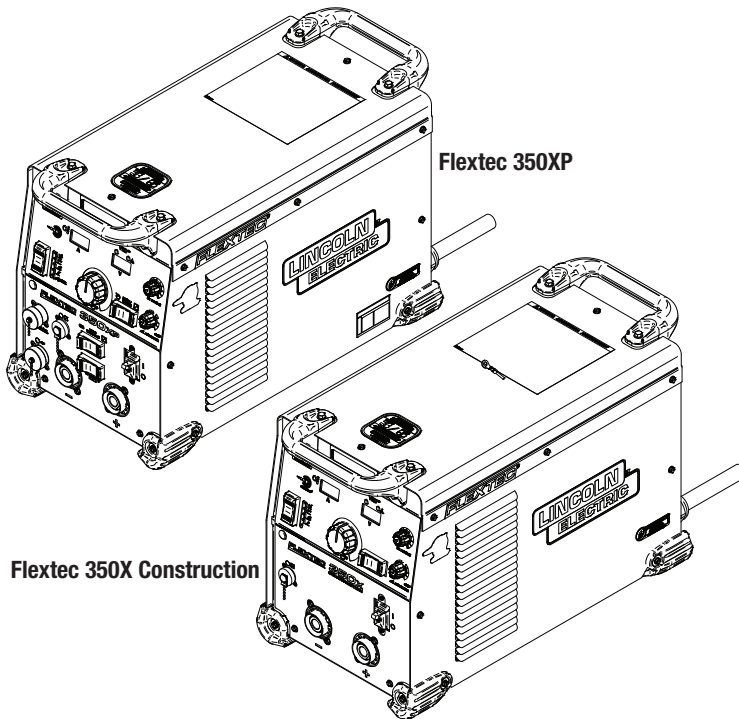

For use with machines having Code Numbers:

Flextec[®] 350XP: 13067, 13071, 13578, 13579

Flextec[®] 350X Construction: 13066, 13070, 13073, 13532, 13581, 13582

Flextec[®] 350XP CE: 13461



Register your machine:
www.lincolnelectric.com/register

Authorized Service and Distributor Locator:
www.lincolnelectric.com/locator

Need Help? Call 1.888.935.3877
to talk to a Service Representative

Hours of Operation:
8:00 AM to 6:00 PM (ET) Mon. thru Fri.

After hours?
Use "Ask the Experts" at lincolnelectric.com
A Lincoln Service Representative will contact you
no later than the following business day.

For Service outside the USA:
Email: globalservice@lincolnelectric.com

Save for future reference

Date Purchased

Code: (ex: 10859)

Serial: (ex: U1060512345)



THANK YOU FOR SELECTING A QUALITY PRODUCT BY LINCOLN ELECTRIC.

PLEASE EXAMINE CARTON AND EQUIPMENT FOR DAMAGE IMMEDIATELY

When this equipment is shipped, title passes to the purchaser upon receipt by the carrier. Consequently, claims for material damaged in shipment must be made by the purchaser against the transportation company at the time the shipment is received.

SAFETY DEPENDS ON YOU

Lincoln arc welding and cutting equipment is designed and built with safety in mind. However, your overall safety can be increased by proper installation ... and thoughtful operation on your part. **DO NOT INSTALL, OPERATE OR REPAIR THIS EQUIPMENT WITHOUT READING THIS MANUAL AND THE SAFETY PRECAUTIONS CONTAINED THROUGHOUT.** And, most importantly, think before you act and be careful.

WARNING

This statement appears where the information must be followed exactly to avoid serious personal injury or loss of life.

CAUTION

This statement appears where the information must be followed to avoid minor personal injury or damage to this equipment.



KEEP YOUR HEAD OUT OF THE FUMES.

DON'T get too close to the arc. Use corrective lenses if necessary to stay a reasonable distance away from the arc.

READ and obey the Safety Data Sheet (SDS) and the warning label that appears on all containers of welding materials.

USE ENOUGH VENTILATION or exhaust at the arc, or both, to keep the fumes and gases from your breathing zone and the general area.

IN A LARGE ROOM OR OUTDOORS, natural ventilation may be adequate if you keep your head out of the fumes (See below).

USE NATURAL DRAFTS or fans to keep the fumes away from your face.

If you develop unusual symptoms, see your supervisor. Perhaps the welding atmosphere and ventilation system should be checked.

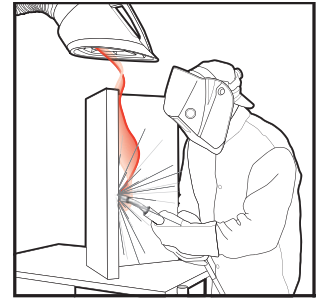

WEAR CORRECT EYE, EAR & BODY PROTECTION

PROTECT your eyes and face with welding helmet properly fitted and with proper grade of filter plate (See ANSI Z49.1).

PROTECT your body from welding spatter and arc flash with protective clothing including woolen clothing, flame-proof apron and gloves, leather leggings, and high boots.

PROTECT others from splatter, flash, and glare with protective screens or barriers.

IN SOME AREAS, protection from noise may be appropriate.

BE SURE protective equipment is in good condition.

Also, wear safety glasses in work area **AT ALL TIMES.**



SPECIAL SITUATIONS

DO NOT WELD OR CUT containers or materials which previously had been in contact with hazardous substances unless they are properly cleaned. This is extremely dangerous.

DO NOT WELD OR CUT painted or plated parts unless special precautions with ventilation have been taken. They can release highly toxic fumes or gases.

Additional precautionary measures

PROTECT compressed gas cylinders from excessive heat, mechanical shocks, and arcs; fasten cylinders so they cannot fall.

BE SURE cylinders are never grounded or part of an electrical circuit.

REMOVE all potential fire hazards from welding area.

ALWAYS HAVE FIRE FIGHTING EQUIPMENT READY FOR IMMEDIATE USE AND KNOW HOW TO USE IT.



SECTION A: WARNINGS



CALIFORNIA PROPOSITION 65 WARNINGS



WARNING: Breathing diesel engine exhaust exposes you to chemicals known to the State of California to cause cancer and birth defects, or other reproductive harm.

- Always start and operate the engine in a well-ventilated area.
- If in an exposed area, vent the exhaust to the outside.
- Do not modify or tamper with the exhaust system.
- Do not idle the engine except as necessary.

For more information go to www.P65warnings.ca.gov/diesel

WARNING: This product, when used for welding or cutting, produces fumes or gases which contain chemicals known to the State of California to cause birth defects and, in some cases, cancer. (California Health & Safety Code § 25249.5 *et seq.*)



WARNING: Cancer and Reproductive Harm
www.P65warnings.ca.gov

ARC WELDING CAN BE HAZARDOUS. PROTECT YOURSELF AND OTHERS FROM POSSIBLE SERIOUS INJURY OR DEATH. KEEP CHILDREN AWAY. PACEMAKER WEARERS SHOULD CONSULT WITH THEIR DOCTOR BEFORE OPERATING.

Read and understand the following safety highlights. For additional safety information, it is strongly recommended that you purchase a copy of "Safety in Welding & Cutting - ANSI Standard Z49.1" from the American Welding Society, P.O. Box 351040, Miami, Florida 33135 or CSA Standard W117.2. A Free copy of "Arc Welding Safety" booklet E205 is available from the Lincoln Electric Company, 22801 St. Clair Avenue, Cleveland, Ohio 44117-1199.

BE SURE THAT ALL INSTALLATION, OPERATION, MAINTENANCE AND REPAIR PROCEDURES ARE PERFORMED ONLY BY QUALIFIED INDIVIDUALS.



FOR ENGINE POWERED EQUIPMENT.

- Turn the engine off before troubleshooting and maintenance work unless the maintenance work requires it to be running.
- Operate engines in open, well-ventilated areas or vent the engine exhaust fumes outdoors.
- Do not add the fuel near an open flame welding arc or when the engine is running. Stop the engine and allow it to cool before refueling to prevent spilled fuel from vaporizing on contact



with hot engine parts and igniting. Do not spill fuel when filling tank. If fuel is spilled, wipe it up and do not start engine until fumes have been eliminated.

- Keep all equipment safety guards, covers and devices in position and in good repair. Keep hands, hair, clothing and tools away from V-belts, gears, fans and all other moving parts when starting, operating or repairing equipment.
- In some cases it may be necessary to remove safety guards to perform required maintenance. Remove guards only when necessary and replace them when the maintenance requiring their removal is complete. Always use the greatest care when working near moving parts.
- Do not put your hands near the engine fan. Do not attempt to override the governor or idler by pushing on the throttle control rods while the engine is running.
- To prevent accidentally starting gasoline engines while turning the engine or welding generator during maintenance work, disconnect the spark plug wires, distributor cap or magneto wire as appropriate.
- To avoid scalding, do not remove the radiator pressure cap when the engine is hot.
- Using a generator indoors CAN KILL YOU IN MINUTES.
- Generator exhaust contains carbon monoxide. This is a poison you cannot see or smell.
- NEVER use inside a home or garage, EVEN IF doors and windows are open.
- Only use OUTSIDE and far away from windows, doors and vents.
- Avoid other generator hazards. READ MANUAL BEFORE USE.



ELECTRIC AND MAGNETIC FIELDS MAY BE DANGEROUS



- Electric current flowing through any conductor causes localized Electric and Magnetic Fields (EMF). Welding current creates EMF fields around welding cables and welding machines
- EMF fields may interfere with some pacemakers, and welders having a pacemaker should consult their physician before welding.
- Exposure to EMF fields in welding may have other health effects which are now not known.
- All welders should use the following procedures in order to minimize exposure to EMF fields from the welding circuit:
 - Route the electrode and work cables together - Secure them with tape when possible.
 - Never coil the electrode lead around your body.
 - Do not place your body between the electrode and work cables. If the electrode cable is on your right side, the work cable should also be on your right side.
 - Connect the work cable to the workpiece as close as possible to the area being welded.
 - Do not work next to welding power source.



ELECTRIC SHOCK CAN KILL.



- 3.a. The electrode and work (or ground) circuits are electrically “hot” when the welder is on. Do not touch these “hot” parts with your bare skin or wet clothing. Wear dry, hole-free gloves to insulate hands.
- 3.b. Insulate yourself from work and ground using dry insulation. Make certain the insulation is large enough to cover your full area of physical contact with work and ground.

In addition to the normal safety precautions, if welding must be performed under electrically hazardous conditions (in damp locations or while wearing wet clothing; on metal structures such as floors, gratings or scaffolds; when in cramped positions such as sitting, kneeling or lying, if there is a high risk of unavoidable or accidental contact with the workpiece or ground) use the following equipment:

- Semiautomatic DC Constant Voltage (Wire) Welder.
 - DC Manual (Stick) Welder.
 - AC Welder with Reduced Voltage Control.
- 3.c. In semiautomatic or automatic wire welding, the electrode, electrode reel, welding head, nozzle or semiautomatic welding gun are also electrically “hot”.
 - 3.d. Always be sure the work cable makes a good electrical connection with the metal being welded. The connection should be as close as possible to the area being welded.
 - 3.e. Ground the work or metal to be welded to a good electrical (earth) ground.
 - 3.f. Maintain the electrode holder, work clamp, welding cable and welding machine in good, safe operating condition. Replace damaged insulation.
 - 3.g. Never dip the electrode in water for cooling.
 - 3.h. Never simultaneously touch electrically “hot” parts of electrode holders connected to two welders because voltage between the two can be the total of the open circuit voltage of both welders.
 - 3.i. When working above floor level, use a safety belt to protect yourself from a fall should you get a shock.
 - 3.j. Also see Items 6.c. and 8.



ARC RAYS CAN BURN.



- 4.a. Use a shield with the proper filter and cover plates to protect your eyes from sparks and the rays of the arc when welding or observing open arc welding. Headshield and filter lens should conform to ANSI Z87.1 standards.
- 4.b. Use suitable clothing made from durable flame-resistant material to protect your skin and that of your helpers from the arc rays.
- 4.c. Protect other nearby personnel with suitable, non-flammable screening and/or warn them not to watch the arc nor expose themselves to the arc rays or to hot spatter or metal.



FUMES AND GASES CAN BE DANGEROUS.



- 5.a. Welding may produce fumes and gases hazardous to health. Avoid breathing these fumes and gases. When welding, keep your head out of the fume. Use enough ventilation and/or exhaust at the arc to keep fumes and gases away from the breathing zone. **When welding hardfacing (see instructions on container or SDS) or on lead or cadmium plated steel and other metals or coatings which produce highly toxic fumes, keep exposure as low as possible and within applicable OSHA PEL and ACGIH TLV limits using local exhaust or mechanical ventilation unless exposure assessments indicate otherwise. In confined spaces or in some circumstances, outdoors, a respirator may also be required. Additional precautions are also required when welding on galvanized steel.**
- 5.b. The operation of welding fume control equipment is affected by various factors including proper use and positioning of the equipment, maintenance of the equipment and the specific welding procedure and application involved. Worker exposure level should be checked upon installation and periodically thereafter to be certain it is within applicable OSHA PEL and ACGIH TLV limits.
- 5.c. Do not weld in locations near chlorinated hydrocarbon vapors coming from degreasing, cleaning or spraying operations. The heat and rays of the arc can react with solvent vapors to form phosgene, a highly toxic gas, and other irritating products.
- 5.d. Shielding gases used for arc welding can displace air and cause injury or death. Always use enough ventilation, especially in confined areas, to insure breathing air is safe.
- 5.e. Read and understand the manufacturer’s instructions for this equipment and the consumables to be used, including the Safety Data Sheet (SDS) and follow your employer’s safety practices. SDS forms are available from your welding distributor or from the manufacturer.
- 5.f. Also see item 1.b.



WELDING AND CUTTING SPARKS CAN CAUSE FIRE OR EXPLOSION.

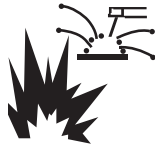

- 6.a. Remove fire hazards from the welding area. If this is not possible, cover them to prevent the welding sparks from starting a fire. Remember that welding sparks and hot materials from welding can easily go through small cracks and openings to adjacent areas. Avoid welding near hydraulic lines. Have a fire extinguisher readily available.
- 6.b. Where compressed gases are to be used at the job site, special precautions should be used to prevent hazardous situations. Refer to "Safety in Welding and Cutting" (ANSI Standard Z49.1) and the operating information for the equipment being used.
- 6.c. When not welding, make certain no part of the electrode circuit is touching the work or ground. Accidental contact can cause overheating and create a fire hazard.
- 6.d. Do not heat, cut or weld tanks, drums or containers until the proper steps have been taken to insure that such procedures will not cause flammable or toxic vapors from substances inside. They can cause an explosion even though they have been "cleaned". For information, purchase "Recommended Safe Practices for the Preparation for Welding and Cutting of Containers and Piping That Have Held Hazardous Substances", AWS F4.1 from the American Welding Society (see address above).
- 6.e. Vent hollow castings or containers before heating, cutting or welding. They may explode.
- 6.f. Sparks and spatter are thrown from the welding arc. Wear oil free protective garments such as leather gloves, heavy shirt, cuffless trousers, high shoes and a cap over your hair. Wear ear plugs when welding out of position or in confined places. Always wear safety glasses with side shields when in a welding area.
- 6.g. Connect the work cable to the work as close to the welding area as practical. Work cables connected to the building framework or other locations away from the welding area increase the possibility of the welding current passing through lifting chains, crane cables or other alternate circuits. This can create fire hazards or overheat lifting chains or cables until they fail.
- 6.h. Also see item 1.c.
- 6.i. Read and follow NFPA 51B "Standard for Fire Prevention During Welding, Cutting and Other Hot Work", available from NFPA, 1 Batterymarch Park, PO box 9101, Quincy, MA 022690-9101.
- 6.j. Do not use a welding power source for pipe thawing.



CYLINDER MAY EXPLODE IF DAMAGED.

- 7.a. Use only compressed gas cylinders containing the correct shielding gas for the process used and properly operating regulators designed for the gas and pressure used. All hoses, fittings, etc. should be suitable for the application and maintained in good condition. 
- 7.b. Always keep cylinders in an upright position securely chained to an undercarriage or fixed support.
- 7.c. Cylinders should be located:
 - Away from areas where they may be struck or subjected to physical damage.
 - A safe distance from arc welding or cutting operations and any other source of heat, sparks, or flame.
- 7.d. Never allow the electrode, electrode holder or any other electrically "hot" parts to touch a cylinder.
- 7.e. Keep your head and face away from the cylinder valve outlet when opening the cylinder valve.
- 7.f. Valve protection caps should always be in place and hand tight except when the cylinder is in use or connected for use.
- 7.g. Read and follow the instructions on compressed gas cylinders, associated equipment, and CGA publication P-1, "Precautions for Safe Handling of Compressed Gases in Cylinders," available from the Compressed Gas Association, 14501 George Carter Way Chantilly, VA 20151.



FOR ELECTRICALLY POWERED EQUIPMENT.



- 8.a. Turn off input power using the disconnect switch at the fuse box before working on the equipment.
- 8.b. Install equipment in accordance with the U.S. National Electrical Code, all local codes and the manufacturer's recommendations.
- 8.c. Ground the equipment in accordance with the U.S. National Electrical Code and the manufacturer's recommendations.

Refer to
<http://www.lincolnelectric.com/safety>
for additional safety information.

ELECTROMAGNETIC COMPATIBILITY (EMC)

CONFORMANCE

Products displaying the CE mark are in conformity with European Community Council Directive of 15 Dec 2004 on the approximation of the laws of the Member States relating to electromagnetic compatibility, 2014/30/EU. It was manufactured in conformity with a national standard that implements a harmonized standard: EN 60974-10 Electromagnetic Compatibility (EMC) Product Standard for Arc Welding Equipment. It is for use with other Lincoln Electric equipment. It is designed for industrial and professional use.

INTRODUCTION

All electrical equipment generates small amounts of electromagnetic emission. Electrical emission may be transmitted through power lines or radiated through space, similar to a radio transmitter. When emissions are received by other equipment, electrical interference may result. Electrical emissions may affect many kinds of electrical equipment; other nearby welding equipment, radio and TV reception, numerical controlled machines, telephone systems, computers, etc.

Warning: This Class A equipment is not intended for use in residential locations where the electrical power is provided by the public low-voltage supply system. There may be potential difficulties in ensuring electro-magnetic compatibility in those locations, due to conducted as well as radiated disturbances.

This machine has been designed to operate in an industrial area. The operator must install and operate this equipment as described in this manual. If any electromagnetic disturbances are detected the operator must put in place corrective actions to eliminate these disturbances with, if necessary, assistance from Lincoln Electric. This equipment does not comply with IEC 61000-3-12. If it is connected to a public low-voltage system, it is responsibility of the installer or user of the equipment to ensure, by consultation with the distribution network operator if necessary, that the equipment may be connected.

INSTALLATION AND USE

The user is responsible for installing and using the welding equipment according to the manufacturer's instructions.

If electromagnetic disturbances are detected then it shall be the responsibility of the user of the welding equipment to resolve the situation with the technical assistance of the manufacturer. In some cases this remedial action may be as simple as earthing (grounding) the welding circuit, see Note. In other cases it could involve constructing an electromagnetic screen enclosing the power source and the work complete with associated input filters. In all cases electromagnetic disturbances must be reduced to the point where they are no longer troublesome.

Note: The welding circuit may or may not be earthed for safety reasons. Follow your local and national standards for installation and use. Changing the earthing arrangements should only be authorized by a person who is competent to assess whether the changes will increase the risk of injury, e.g., by allowing parallel welding current return paths which may damage the earth circuits of other equipment.

ASSESSMENT OF AREA

Before installing welding equipment the user shall make an assessment of potential electromagnetic problems in the surrounding area. The following shall be taken into account:

- a) other supply cables, control cables, signaling and telephone cables; above, below and adjacent to the welding equipment;
- b) radio and television transmitters and receivers;
- c) computer and other control equipment;
- d) safety critical equipment, e.g., guarding of industrial equipment;
- e) the health of the people around, e.g., the use of pacemakers and hearing aids;
- f) equipment used for calibration or measurement;
- g) the immunity of other equipment in the environment. The user shall ensure that other equipment being used in the environment is compatible. This may require additional protection measures;
- h) the time of day that welding or other activities are to be carried out.

The size of the surrounding area to be considered will depend on the structure of the building and other activities that are taking place. The surrounding area may extend beyond the boundaries of the premises.

METHODS OF REDUCING EMISSIONS

Public Supply System

Welding equipment should be connected to the public supply system according to the manufacturer's recommendations. If interference occurs, it may be necessary to take additional precautions such as filtering of the system. Consideration should be given to shielding the supply cable of permanently installed welding equipment, in metallic conduit or equivalent. Shielding should be electrically continuous throughout its length. The shielding should be connected to the welding power source so that good electrical contact is maintained between the conduit and the welding power source enclosure.

Maintenance of the Welding Equipment

The welding equipment should be routinely maintained according to the manufacturer's recommendations. All access and service doors and covers should be closed and properly fastened when the welding equipment is in operation. The welding equipment should not be modified in any way except for those changes and adjustments covered in the manufacturer's instructions. In particular, the spark gaps of arc striking and stabilizing devices should be adjusted and maintained according to the manufacturer's recommendations.

Welding Cables

The welding cables should be kept as short as possible and should be positioned close together, running at or close to the floor level.

Equipotential Bonding

Bonding of all metallic components in the welding installation and adjacent to it should be considered. However, metallic components bonded to the work piece will increase the risk that the operator could receive a shock by touching these metallic components and the electrode at the same time. The operator should be insulated from all such bonded metallic components.

Earthing of the Workpiece

Where the workpiece is not bonded to earth for electrical safety, nor connected to earth because of its size and position, e.g., ship's hull or building steelwork, a connection bonding the workpiece to earth may reduce emissions in some, but not all instances. Care should be taken to prevent the earthing of the workpiece increasing the risk of injury to users, or damage to other electrical equipment. Where necessary, the connection of the workpiece to earth should be made by a direct connection to the workpiece, but in some countries where direct connection is not permitted, the bonding should be achieved by suitable capacitance, selected according to national regulations.

Screening and Shielding

Selective screening and shielding of other cables and equipment in the surrounding area may alleviate problems of interference. Screening of the entire welding installation may be considered for special applications.

ECO Design Information

The equipment has been designed in order to be compliant with the Directive 2009/125/EC and the Regulation 2019/1784/EU.

Efficiency and idle power consumption:

Name	Efficiency when max power consumption / Idle power consumption
Flextec 350XP CE	87.00% / 39W

idle state, set the Weld Terminals to off and Local/Remote to remote and wait until the fan is off. The fan will be off when the units are powered up, or will turn off after a delay of (up to) 5 minutes if the welding output was just disabled.

ECO Mode will be enabled after 1 hour of inactivity on the machine. ECO will be displayed on the left display and the machine's weld terminal voltage, fans, and power to feeders will be disabled. This mode allows the power source to reduce its idle power consumption. The machine will exit ECO Mode when a user presses the process select rocker switch.

The value of efficiency and consumption in idle state have been measured by method and conditions defined in the product standard EN 60974-1

Manufacturer's name, product name, code number, product number, serial number and date of production can be read from rating plate and serial number label.

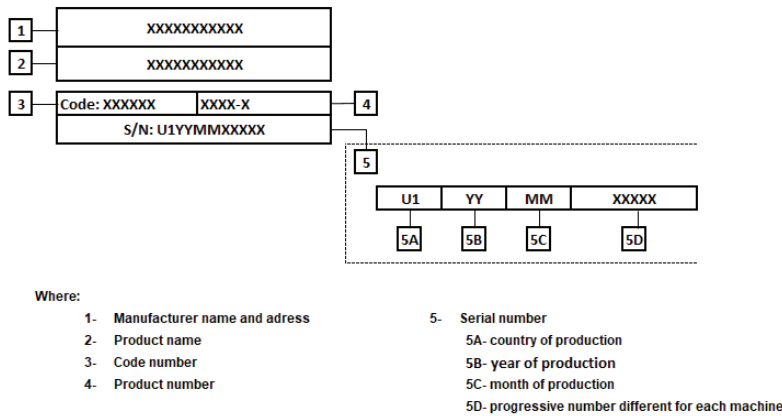

Typical gas usage for **MIG/MAG** equipment:

Material type	Wire diameter [mm]	DC electrode positive		Wire Feeding [m/min]	Shielding Gas	Gas flow [l/min]
		Current [A]	Voltage [V]			
Carbon, low alloy steel	0,9 - 1,1	95 - 200	18 - 22	3,5 – 6,5	Ar 75%, CO ₂ 25%	12
Aluminum	0,8 - 1,6	90 - 240	18 - 26	5,5 – 9,5	Argon	14 - 19
Austenitic stainless steel	0,8 - 1,6	85 - 300	21 - 28	3 - 7	Ar 98%, O ₂ 2% / He 90%, Ar 7,5% CO ₂ 2,5%	14 - 16
Copper alloy	0,9 - 1,6	175 - 385	23 - 26	6 - 11	Argon	12 - 16
Magnesium	1,6 - 2,4	70 - 335	16 - 26	4 - 15	Argon	24 - 28

Tig Process:

In TIG welding process, gas usage depends on cross-sectional area of the nozzle. For comonly used torches:

Helium: 14-24 l/min

Argon: 7-16 l/min

Notice: Excessive flow rates causes turbulence in the gas stream which may aspirate atmospheric contamination into the welding pool.

Notice: A cross wind or draft moving can disrupt the shielding gas coverage, in the interest of saving of protective gas use screen to block air flow.



End of life

At end of life of product, it has to be disposal for recycling in accordance with Directive 2012/19/EU (WEEE), information about the dismantling of product and Critical Raw Material (CRM) present in the product, can be found at:

www.lincolnelectriceurope.com

Flextec 350X CE
Construction & standard

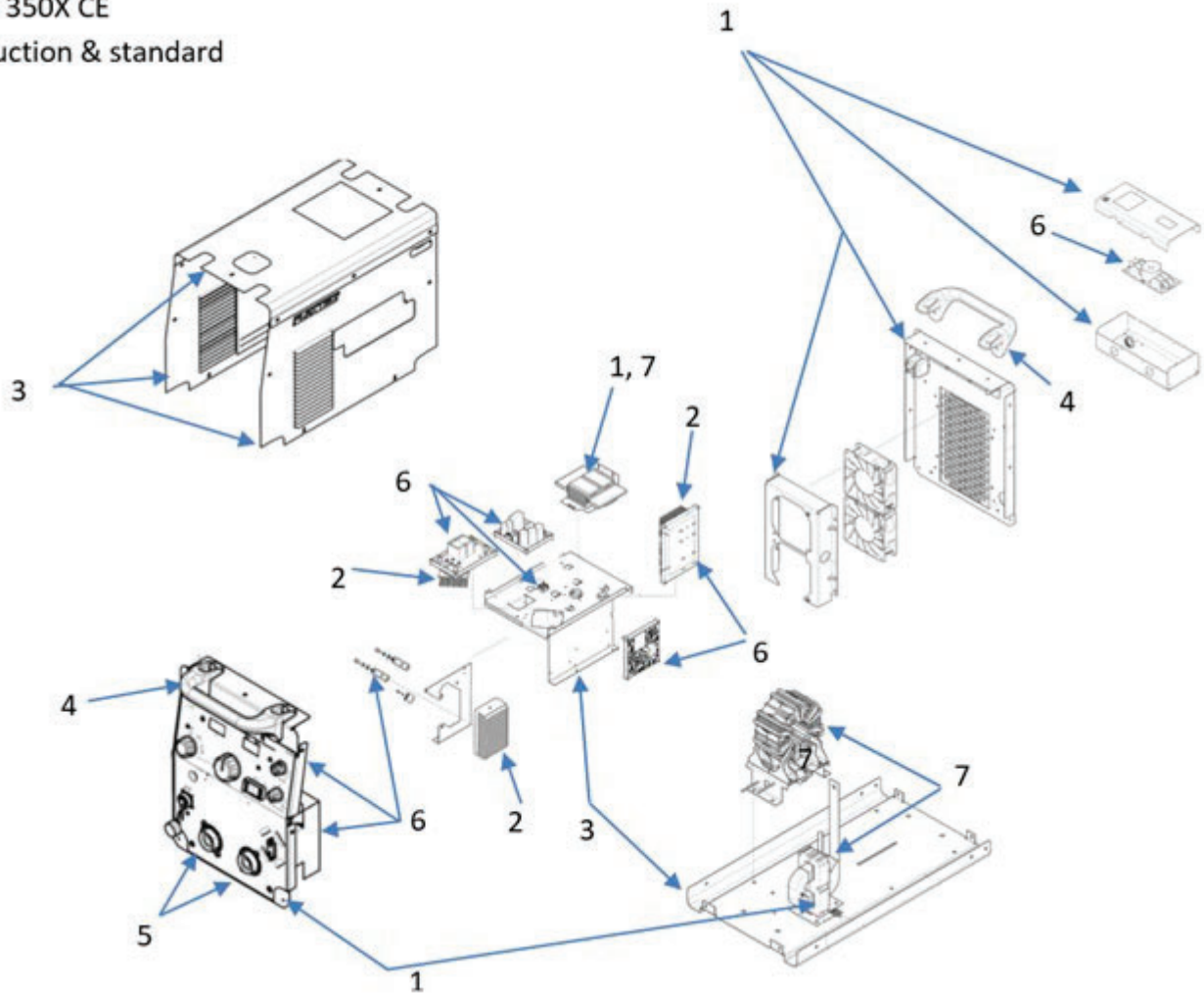

Item	Component	Material for recovery	CRM	Selective treatment
1	Enclosure	Steel	-	-
2	Heat sink	Aluminum	Si, 11 g Mg, 18 g	-
3	Enclosure	Aluminum	Si 6 g Mg 72 g	-
4	Handle	Aluminum	Si, 118 g Mg, 1 g	-
5	Output terminal	Brass	-	-
6	PC board	-	-	Required
7	Choke Transformers Internal cables	Copper	-	-
8	External cables – not shown	Copper	-	Required

Reference: P-1219-A, code 12776

	PAGE
General Description	
GENERAL FUNCTIONAL DESCRIPTION	7
RECOMMENDED PROCESSES	7
PROCESS LIMITATIONS	7
PRODUCT SPECIFIC INSTALLATION LIMITATIONS	7
DESIGN FEATURES	8
INSTALLATION	
COMMON EQUIPMENT PACKAGES	A-1
INPUT AND GROUND CONNECTIONS	A-2
INPUT VOLTAGE SELECTION	A-2
INPUT FUSE AND SUPPLY WIRE CONSIDERATIONS	A-2
LOCATION	A-2
HIGH FREQUENCY PROTECTION	A-2
TECHNICAL SPECIFICATIONS	A-3
CASE FRONT CONTROLS - STANDARD	A-5
CASE FRONT CONTROLS - CONSTRUCTION	A-6
CASE BACK CONTROL	A-7
INTERNAL CONTROLS	A-8
CONNECTIVITY	A-9
RECOMMENDED ELECTRODE AND WORK CABLE SIZES FOR ARC WELDING	A-10
REMOTE SENSE LEAD SPECIFICATIONS	A-11
CONNECTION DIAGRAMS	A-12
OPERATION	
GRAPHIC SYMBOLS USED	B-1
POWER-UP SEQUENCE	B-2
DUTY CYCLE	B-2
THERMAL PROTECTION	B-2
MAKING A WELD	B-2
DEFINITION OF WELDING MODES	B-3
WELD CONTROLS AND DISPLAYS	B-3
BASIC MODES OF OPERATION	B-5
ACCESSORIES	
MAINTENANCE	
CURRENT CALIBRATION	D-1
VOLTAGE CALIBRATION	D-1
FACTORY CURRENT CALIBRATION	D-2
FACTORY VOLTAGE CALIBRATION	D-2
TROUBLESHOOTING	
CHART	E-1
FAULT CODES	E-3
DIAGRAMS	
WIRING DIAGRAM	G-1
DIMENSIONAL PRINT	G-2
PARTS LIST	PARTS.LINCOLNELECTRIC.COM

Content/details may be changed or updated without notice. For most current Instruction Manuals, go to parts.lincolnelectric.com.

GENERAL DESCRIPTION

GENERAL FUNCTIONAL DESCRIPTION

The Flextec 350XP and Flextec 350X Construction are inverter based, multi-process, DC power sources that have a 5 to 425 Amp output range. The machine is capable of welding in CC and CV modes with common wire types and sizes. The Flextec 350 XP and Flextec 350X Construction are both capable of gouging in either Stick or CV modes. Two units can be paralleled in CC modes for extra gouging power. In this document, "Flextec 350XP is used to refer to the Construction model as well unless otherwise specified.

The Standard and Construction models include welding modes for GMAW, FCAW, SMAW, and GTAW for a variety of materials including mild steel, some cored wires, gas shielded wires, and aluminum wires. VRD (Voltage Reduction Device) is offered supporting reduced open circuit voltages for an added measure of safety. The Flextec 350XP Standard machine includes an ArcLink setting that allows the power source to weld synergic modes with ArLink compatible feeders.

The Flextec 350XP Standard is designed to be compatible with the current range of semi-automatic ArLink wire feeders in addition to the analog and across-the-arc wire feeders. The Flextec 350XP Standard comes with a 5-pin ArLink digital feeder connector, a 14-pin analog feeder connector and a 12-pin remote output connector.

The Flextec 350X Construction machine only comes with a 12-pin remote output connector and is only compatible with across the arc wire feeders and CrossLinc® compatible feeders.

All of the models of Flextec 350XP come with CrossLinc® technology for remote voltage setting, without a control cable, with CrossLinc® compatible feeders or remote controls.

RECOMMENDED PROCESSES

Flextec 350XP is designed for CC-SMAW, CC-GTAW (Touch Start TIG™), CV-GMAW, CV-GMAW-P, CV-FCAW-SS, CV-FCAW-G. CAG arc gouging is also supported in the CV and CC modes.

WELD MODE	PROCESS	COMMON MATERIALS	COMMON ELECTRODES
GTAW	TOUCH START TIG® (CC)	STAINLESS, STEEL	
SMAW	STICK-CC	ALUMINUM, STAINLESS, STEEL	6010, 6011, 7018
CV	MIG (GMAW) FCAW-GS	ALUMINUM, STAINLESS, STEEL	L-50; L-56
CV-INNERSHIELD	FCAW-SS	STAINLESS, STEEL	NR-203; NR-211, NR-440N12
ArcLink	CV-GMAW-P*	CARBON STEEL, STAINLESS, STEEL, ALUMINUM	L50; L-56

*GMAW-P is only available in the 350XP model with ArLink feeder.

PROCESS LIMITATIONS

- The Flextec 350XP is only suitable for the processes listed.

PRODUCT SPECIFIC INSTALLATION LIMITATIONS

CrossLinc® technology uses a communication protocol coupled on the electrode and work cables. For best performance the total voltage drop in the system should be kept under 10V.

CrossLinc® is not compatible with High Frequency TIG. If HF is in the area, the cables need to be routed as far as possible from each other. Also follow all high frequency best practices, including the driven earth ground.

DESIGN FEATURES

- **Multiple process DC output range:** 5 - 425 Amps
- **Circuit breaker protected 10 amp auxiliary power** for the 350XP, 3 amp auxiliary power for the Construction, and breaker-less protection for the 350XP CE.
- **Thermostatically protected** with Thermal Light.
- **Simple and Easy to Use**
- **Flexible Multi-Process Capability** – Including stick, TIG, MIG, GMAW-P, Flux-cored and CAG.
- **Bright Digital Amp and Volt Meters** – Easy to monitor, even in sunlight, and presettable for precise procedure control, display error codes for troubleshooting
- **Compact, Durable Case** – Tough IP23 enclosure rating ensures the ability to withstand extreme field environments.
- **Variable Hot Start** – Get the extra starting amperage you need for thick, rusty or dirty material.
- **Variable Arc Control** – In stick mode, vary the arc force to obtain the “soft” or “crisp” arc you want as conditions require. In CV modes vary the pinch or inductance to control spatter, fluidity and bead appearance.
- **Procedure Control** – Utilize ArcLink Feeder capabilities such as user memories and preference options.*
- **Full-Featured Remote Control Capability** – Use a foot pedal or hand control to remotely vary output up to 100 ft. (30.5 mm) away.
- **380 – 575 VAC, 50/60Hz Voltage Input (350XP and Construction models)** - Offers the ability to be connected anywhere in the world without manual reconnect switches or bus bars. **The 350XP CE model is rated for 380 - 415, 50/60Hz Voltage Input.**
- **Voltage Compensation and Reliable Input Voltage Connection** – Provides consistent operation over $\pm 10\%$ input voltage variation.
- **Easy to Parallel Machines** in CC mode.
- **Severe Duty** – Can be stored outdoors. IP23 Rated.
- **Desert Duty Rated** – Welding outputs are rated for extreme temperature operation up to 55°C - welding output is reduced @ 55°C.
- **ArcLink® Wire Feeder Compatible** – unlock synergic modes to increase productivity and control.*
- **Synergic Modes** – for easy, repeatable welds.*
- **VRD** – reduces OCV when not welding for added safety.
- **Low Operating Cost** – Operates at a high efficiency
- **Transport** - Reversible handles for ease of lifting.
- **CrossLinc® technology** allows for remote control of the welding output using the weld cables rather than a control cable when connected to a CrossLinc® compatible wire feeder or remote control.
- **Activ8x Pipe Compatible** - The Flextec 350XP CE is compatible with the Activ8x Pipe to produce advanced STT field and Synergic Pulse Welds.

* Flextec 350XP and 350XP CE only

INSTALLATION

⚠ WARNING

ELECTRIC SHOCK can kill.

ONLY A QUALIFIED ELECTRICIAN SHOULD CONNECT THE INPUT LEADS TO THE FLEXTEC MACHINE. CONNECTIONS SHOULD BE MADE IN ACCORDANCE WITH ALL LOCAL AND NATIONAL ELECTRICAL CODES AND THE CONNECTION DIAGRAM LOCATED UNDERNEATH THE CASE TOP OF THE MACHINE. FAILURE TO DO SO MAY RESULT IN BODILY INJURY OR DEATH.



COMMON EQUIPMENT PACKAGES

COMMON OPTIONAL KITS & ACCESSORIES

K3059-4	INVERTER CART (REQUIRES LOCKING FOOT KIT)
K4424-1	350XP LOCKING FOOT KIT
K5527-1	FLEXTEC TIG SOLENOID KIT
K2909-1	12-PIN TO 6-PIN ADAPTER
K3127-1	WIRELESS FOOT PEDAL (6-PIN)*
K857-2	REMOTE OUTPUT CONTROL WITH 12-PIN UNIVERSAL CONNECTOR (25 FEET)
K857-3	REMOTE OUTPUT CONTROL (12-PIN) (100 FEET)*
K870-2	FOOT AMPPTROL WITH 12-PIN UNIVERSAL CONNECTOR
K963-4	HAND AMPPTROL (12-PIN). *
K4421-1	MILLER RACK ADAPTOR KIT, REQUIRES A LOCKING FOOT KIT
K4345-1	CROSSLINC REMOTE

* Any accessory with a 6-pin connector also needs to use the K2909-1 12-pin to 6-pin adapter.

COMPATIBLE WIRE FEEDERS – ANALOG & ARCLINK FEEDERS

NORTH AMERICAN SEMI-AUTOMATIC WIRE FEEDERS

PF25M, PF84	POWER FEED SERIES (40VDC INPUT)*
LF-72, LF-74	LF SERIES (42VAC INPUT)*
ALL MODELS	FLEX FEED SERIES (42VAC INPUT)*
ALL MODELS	LN-10, DH-10 (42VAC INPUT)*
ALL MODELS	LN-25 PRO SERIES, ACTIV8
ALL MODELS	ACTIV8X / LN-25X / LN-25X WITH CROSSLINC TECHNOLOGY

EUROPEAN SEMI-AUTOMATIC WIRE FEEDERS

PF-44, PF-46	POWER FEED SERIES (EXCLUDING PF42 & PF 40 FOR FLUX CORED)*
LF-33S, LF-33, LF-34, LF-35, LF-37, LF-38, LN-15	LINC FEED SERIES (42VAC INPUTS ONLY)*
LF-45, LF-45S,	LINC FEED SERIES (40VDC INPUTS)*
LF-22M, LF-24M, LF-24 PRO	LINC FEED SERIES (ACROSS THE ARC INPUT)

* Supported with Flextec 350XP Standard and 350XP CE models. Flextec 350X Construction model will not support.

INPUT AND GROUND CONNECTIONS

The Flextec 350XP comes standard with a power cord. Connect the supply lines to 3 phase power and the ground according to your local and national electrical codes.

INPUT VOLTAGE SELECTION

The Flextec 350XP automatically adjusts to work with different input voltages. No reconnect switches or bus bars are required.

INPUT FUSE AND SUPPLY WIRE CONSIDERATIONS

Refer to technical specifications for recommended fuse, wire sizes and type of the copper wires. Fuse the input circuit with the recommended super lag fuse or delay type breakers (also called "inverse time" or "thermal/magnetic" circuit breakers). Choose input and grounding wire size according to local or national electrical codes. Using input wire sizes, fuses or circuit breakers smaller than recommended may result in "nuisance" shut-offs from welder inrush currents, even if the machine is not being used at high currents.

LOCATION

Location and ventilation for cooling

Place the welder where clean cooling air can freely circulate in through the rear louvers and out through the case sides. Dirt, dust, or any foreign material that can be drawn into the welder should be kept at a minimum. Failure to observe these precautions can result in excessive operating temperatures and nuisance shutdowns.

Tilting

Place the machine directly on a secure, level surface or on a recommended undercarriage. The machine may topple over if this procedure is not followed.

Lifting

The Flextec 350XP has two handles that can be used to lift the machine.

Both handles should be used when lifting the machine. When using a crane or overhead device to lift using the handles, a lifting strap should be connected to both handles. Do not attempt to lift the Flextec 350XP with accessories attached to it.

Stacking

The Flextec 350XP cannot be stacked.

Environmental limitations

The Flextec 350XP is IP23 rated for use in an outdoor environment. The machine should not be subjected to falling water during use nor should any parts of it be submerged in water. Doing so may cause improper operation as well as pose a safety hazard. The best practice is to keep the machine in a dry, sheltered area.

Do not mount the Flextec 350XP over combustible surfaces. Where there is a combustible surface directly under stationary or fixed electrical equipment, that surface shall be covered with a steel plate at least .060" (1.6mm) thick, which shall extend not less than 5.90" (150mm) beyond the equipment on all sides.

HIGH FREQUENCY PROTECTION

Locate the Flextec 350XP away from radio controlled machinery. The normal operation of the Flextec 350XP may adversely affect the operation of RF controlled equipment, which may result in bodily injury or damage to the equipment.

TECHNICAL SPECIFICATIONS -

K4271-2 Flextec 350X CONSTRUCTION - Tweco

K4272-2 Flextec 350XP STANDARD - Tweco

K3441-2 Flextec 350X CONSTRUCTION - Twist Mate

K3442-2 Flextec 350XP - Twist Mate

K4272-2-SB Flextec 350X CONSTRUCTION - Sunbelt

K5422-1 Flextec 350XP CE - Twist Mate

POWER SOURCES - INPUT VOLTAGE AND CURRENT					
PRODUCT #	DUTY CYCLE	INPUT VOLTAGE ± 10%	INPUT AMPERES	IDLE AMPS	POWER FACTOR
K4271-2, K4272-2, K3441-2, K3442-2, K4272-2 SB	60% RATING	380 - 575V 3 Phase 50 or 60 Hz	25/28/22	.13/.16/.27	.87/.77/.62
	100% RATING		21/23/23		.84/.70/.61
K5422-1	60% RATING	380/400/415	34/32/30	1.3/1.4/1.4	.62/.62/.65
	100% RATING		31/26/25		.62/.62/.62

POWER SOURCES - RECOMMENDED INPUT WIRE AND FUSE SIZES ¹					
PRODUCT #	VOLTAGE	INPUT AMPERES	FUSE (SUPER LAG) OR BREAKER SIZE ²	TYPE S, SJ, SJO AND SJT FLEXIBLE CORD WITH AMBIENT TEMPERATURE OF 30C	NOTES
K4271-2, K4272-2, K3441-2, K3442-2, K4272-2 SB	380/3/50	21A	35A	10 AWG	
	460/3/60	23A	35A	10 AWG	
	575/3/60	18A	35A	10 AWG	
K5422-1	380/3/50	31A	45A	8 AWG	

- 1 Cord and Fuse Sizes based upon the U.S. National Electric Code and maximum output
- 2 Also called 'inverse time' or 'thermal/magnetic' circuit breakers; circuit breakers that have a delay in tripping action that decreases as the magnitude of current increases.

RATED OUTPUT			
PROCESS	DUTY CYCLE	VOLTS AT RATED AMPERES	AMPERES
GMAW (CV)	60%	31.5V	350A
	100%	29V	300A
GTAW (CC)	60%	24V	350A
	100%	22V	300A
SMAW (CC)	60%	34V	350A
	100%	32V	300A
FCAW-GS (CV)	60%	31.5V	350A
	100%	29V	300A
FCAW-SS (CV)	60%	31.5V	350A
	100%	29V	300A

RATED OUTPUT IEC60974-1		
DUTY CYCLE	VOLTS AT RATED AMPERES	AMPERES
60%	34	350
100%	32	300

PHYSICAL DIMENSIONS				
MODEL	HEIGHT	WIDTH	DEPTH	WEIGHT
All Models	17.0 IN (432 MM)	13.0 IN (330 MM)	27.0 IN (609 MM)	74 LBS (33.6 KG)
				79 LBS (35.8 KG)

TEMPERATURE RANGES		
OPERATING TEMPERATURE	STORAGE TEMPERATURE	INSULATION CLASS
-4°F TO 131°F (-10°C TO 55°C)*	-40°F TO 185°F (-40°C TO 85°C)	CLASS H (180°C), CLASS F (155°)

AGENCY APPROVALS			
MODEL	MARKET	CONFORMITY MARK	STANDARD
ALL (Except K5422-1)	US AND CANADA	cCSA _{US}	CAN/CSA - E60974-1 ANSI/IEC - 60974-1 IEC 60974-1
K5422-1	EUROPE / INTERNATIONAL	CE	EN/IEC 60974-1 EN/IEC 60974-10 Class A

*Power Source is de-rated at temperatures above 40C

CASE FRONT CONTROL - STANDARD

FIGURE A.1A

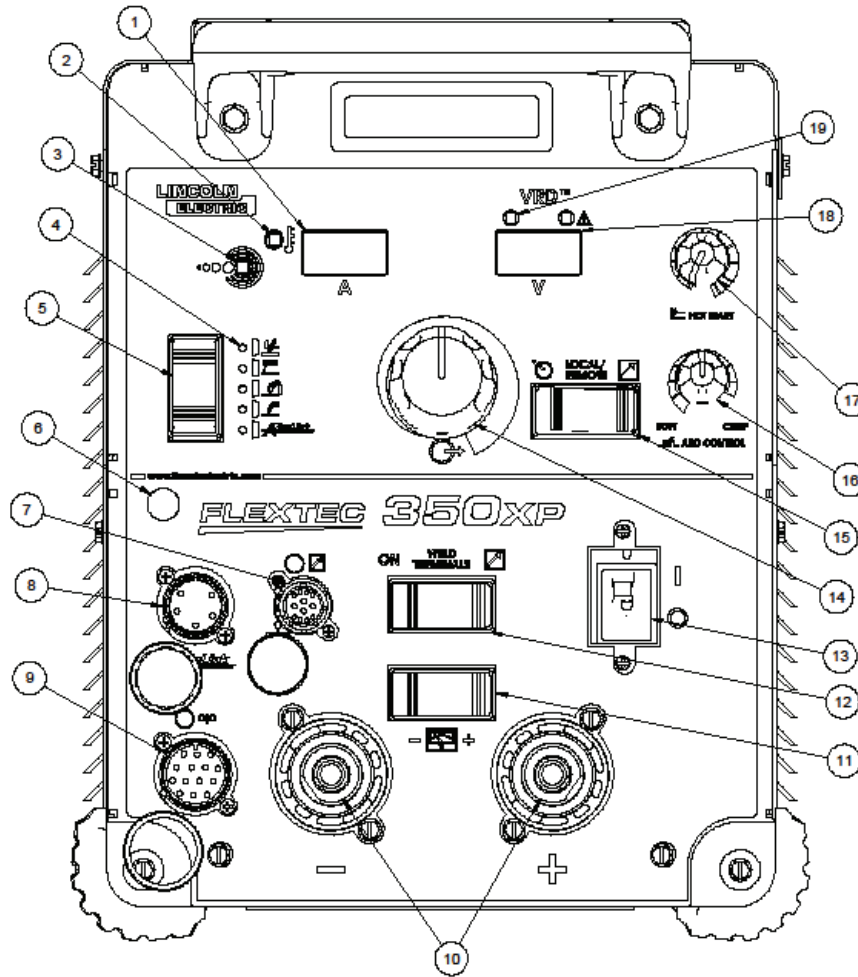

- | | |
|--|---|
| <ol style="list-style-type: none"> 1. Amperage LCD Display 2. Thermal LED: A yellow light that comes on when an over temperature situation occurs. Output is disabled until the machine cools down. When cool, the light goes out and output is enabled. 3. CrossLinc Communication Indicator: When green, the power source is connected to a feeder via CrossLinc. 4. Process Indicator LEDs: Red LEDs that indicate which of the five Flextec 350XP local weld processes are engaged - CC-GTAW, CC-SMAW, CV, CV-Innershield, and ArcLink. 5. Process Indicator Switch: Momentary rocker switch to select weld modes. 6. Optional TIG Solenoid Outlet: Remove plug button to install K5527-1 TIG Solenoid Kit. 7. 12-Pin Remote: Circular connector for attaching optional remote control devices. 8. 5-Pin ArcLink: Wire feeder circular connector. 9. 14-Pin Wire Feeder: Circular connector for attaching wire feeder control cables 10. Positive and Negative Welding Output Connection | <ol style="list-style-type: none"> 11. Wire Feeder Voltmeter: Polarity selection switch matches the polarity of the wire feeder voltmeter to the polarity of the electrode. 12. Weld Terminals On/Remote: Selector switch sets output terminals ON all the time or remotely controlled by a wire feeder or remote device. 13. Power Switch: Controls input power to the Flextec 350XP. 14. Output Control Dial: Sets the Output Current or Voltage for the selected Weld Process. 15. Local/Remote Selector Toggle Switch: Choose machine output to be controlled locally through the output control knob or remotely via a remote device connected to the 12-pin or 14-pin connector (i.e. hand amptrol or K870 foot amptrol). A device connected through CrossLinc technology will override this setting. 16. Arc Force Control Dial: Full range selection of arc force from -10 to +10. 17. Hot Start Control Dial: Full range selection of hot start from 0 to 10. 18. Voltage LCD Display 19. VRD LED Indicators |
|--|---|

CASE FRONT CONTROL - CONSTRUCTION

FIGURE A.1B

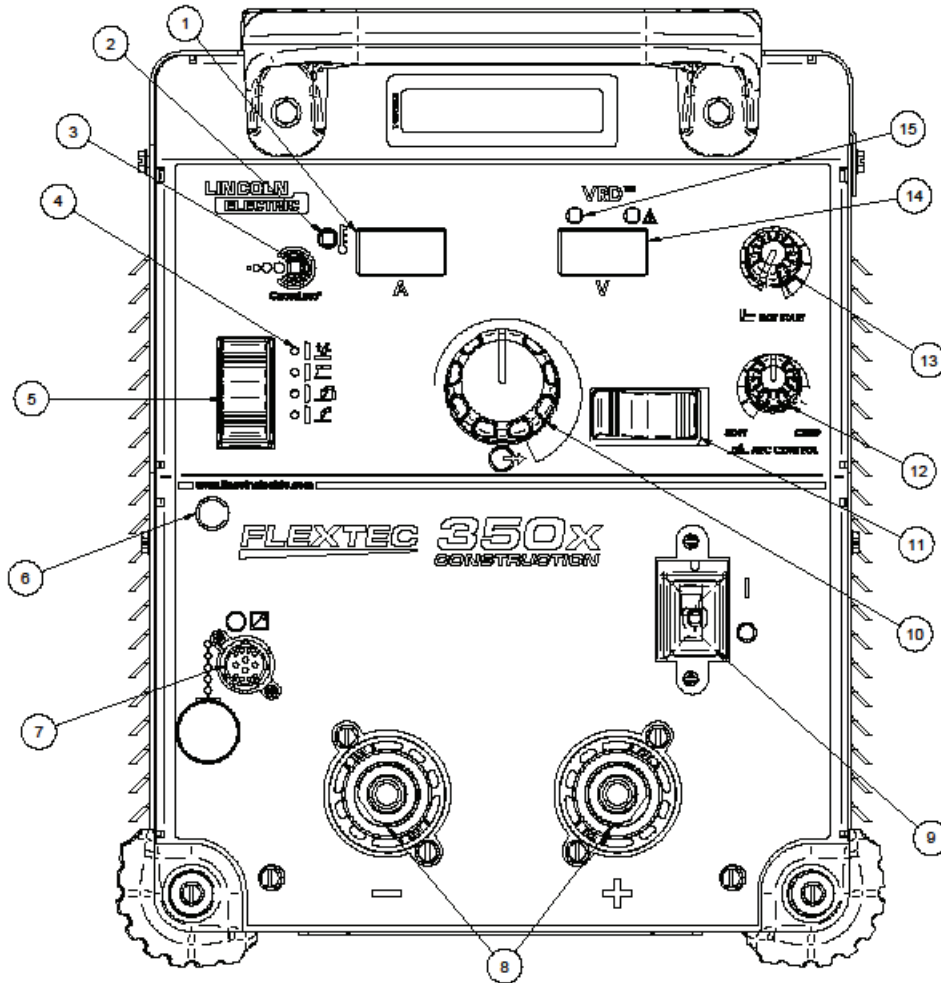

1. **Amperage LCD Display**
2. **Thermal LED:** A yellow light that comes on when an over temperature situation occurs. Output is disabled until the machine cools down. When cool, the light goes out and output is enabled.
3. **CrossLinc Communication Indicator:** When green, the power source is connected to a feeder via CrossLinc.
4. **Process Indicator LEDs:** Red LEDs that indicate which of the five Flextec 350XP local weld processes are engaged - CC-GTAW, CC-SMAW, CV, and CV-Innershield.
5. **Process Indicator Switch:** Momentary rocker switch to select weld modes.
6. **Optional TIG Solenoid Outlet:** Remove plug button to install K5527-1 TIG Solenoid Kit.
7. **12-Pin Remote:** Circular connector for attaching optional remote control devices.
8. **Positive and Negative Welding Output Connection**
9. **Power Switch:** Controls input power to the Flextec 350XP Construction.
10. **Output Control Dial:** Sets the Output Current or Voltage for the selected Weld Process.
11. **Local/Remote Selector Toggle Switch:** Choose machine output to be controlled locally through the output control knob or remotely via a remote device connected to the 12-pin connector (i.e. hand amptrol or K870 foot amptrol). A device connected through CrossLinc technology will override this setting.
12. **Arc Force Control Dial:** Full range selection of arc force from -10 to +10.
13. **Hot Start Control Dial:** Full range selection of hot start from 0 to 10.
14. **Voltage LCD Display**
15. **VRD LED Indicators**

CASE BACK CONTROLS

FIGURE A.2

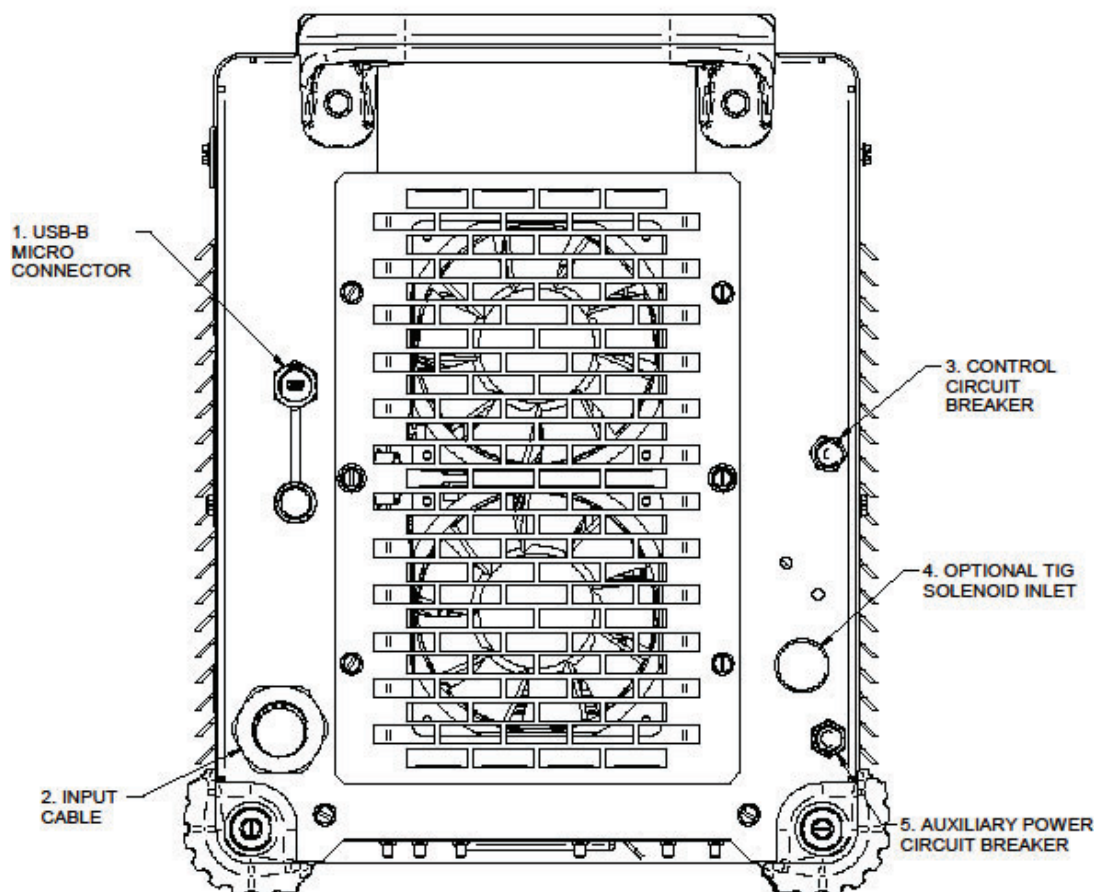

- 1. USB-B Micro Connector:** Remove cap and connect to computer to re-program machine software. Replace cap for environmental protection.
- 2. Input Cable:** Comes with domestic and CE machines (not included for CCC model).
- 3. Control Circuit Breaker:** 20A on all but CE models.
- 4. Optional TIG Solenoid Inlet:** Remove plug button to install K5527-1 TIG Solenoid Kit.
- 5. Auxiliary Power Circuit Breaker:** 3A on Construction models, 10A on standard models, and not present on CE model.

INTERNAL CONTROLS

FIGURE A.3 - DIP SWITCH LOCATION ON USER INTERFACE PCB

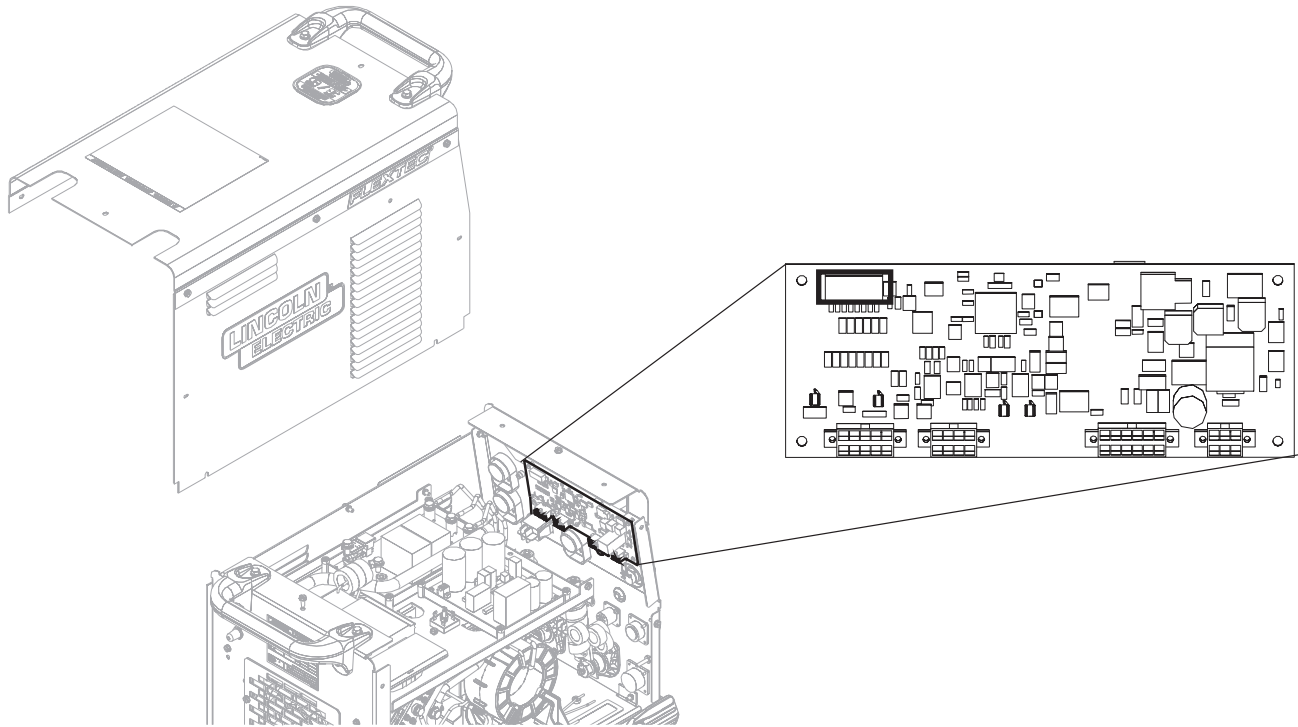

The User Interface pc board has one bank of dip switches. As shipped from the factory and under normal conditions, the dip switches are all in the 'off' position. There are 3 instances that require a change of the dip switch.

Factory Default Setting

- All Switches in the 'OFF' Position

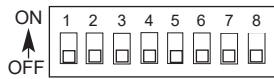

Test Mode Setting

1. **Enter a test mode.** This is utilized when the machine is connected to a grid load for servicing
 - a. Turn switch #4 to the 'ON' position.

- Switch #4 in the 'ON' Position

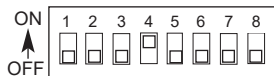

VRD Enabled Setting

2. **Enter VRD Mode (VRD Enabled)**
 - a. Turn switch #5 to the 'ON' Position

- Switch #5 in the 'ON' Position

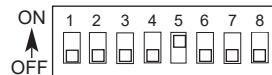

Calibration

3. **Enter Calibration Mode.** This allows the machine voltage and current to be calibrated while connected to a grid load
 - a. Turn switch #1 to the "ON" Position

- Switch #1 in the 'ON' Position

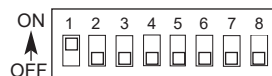

ANALOG WIRE FEEDER CONNECTIVITY

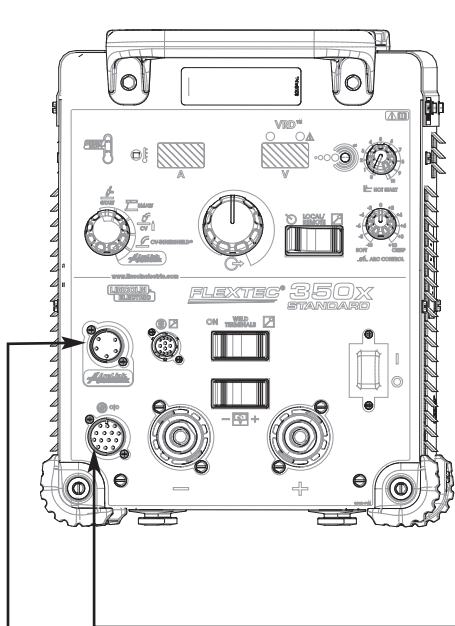

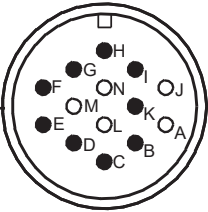
Picture	Function	Pin	Wiring
	14-PIN CONNECTOR FOR WIRE FEEDER CONNECTIVITY.	A	
		B	GROUND
		C	TRIGGER, COMMON
		D	TRIGGER INPUT
		E	77 REMOTE POTENTIOMETER, 5K
		F	76 REMOTE POTENTIOMETER, WIPER
		G	75 REMOTE POTENTIOMETER, COMMON
		H	VOLTAGE SENSE (21)
		I	40 VDC
		J	
		K	40 VDC
		L	
		M	

ARCLINK WIRE FEEDER & DIGITAL ACCESSORY CONNECTIVITY

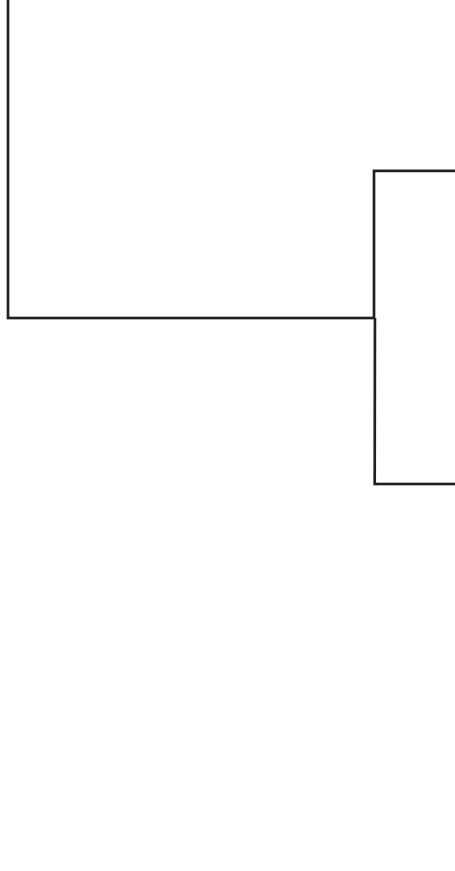

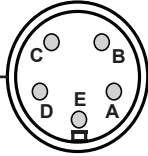
Picture	Function	Pin	Wiring
	5-PIN CONNECTOR FOR WIRE FEEDER CONNECTIVITY	A	ARCLINK CAN
		B	ARCLINK CAN
		C	ELECTRODE SENSE LEAD
		D	40VDC
		E	40VDC COMMON

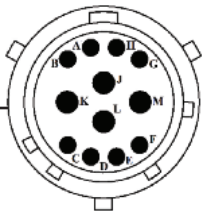
Picture	Function	Pin	Wiring
	12-PIN REMOTE CONTROL CONNECTOR FOR REMOTE OR HAND/FOOT AMPCTRL AND DIGITAL ACCESSORIES.	A	ARCLINK CAN
		B	ARCLINK CAN
		C	REMOTE POTENTIOMETER COMMON
		D	REMOTE POTENTIOMETER WIPER
		E	REMOTE POTENTIOMETER +10V
		F	ALPS CONNECTION
		G	TRIGGER
		H	TRIGGER
		J	40VDC COMMON
		K	40VDC
		L	NOT USED
		M	NOT USED

RECOMMENDED ELECTRODE AND WORK CABLE SIZES FOR ARC WELDING

Connect the electrode and work cables between the appropriate output studs of the Flextec 350XP per the following guidelines:

- Most welding applications run with the electrode being positive (+). For those applications, connect the electrode cable between the wire drive input power connector and the positive (+) output stud on the power source. Connect a work lead from the negative (-) power source output stud to the work piece.
- When negative electrode polarity is required, such as in some Innershield applications, reverse the output connections at the power source (electrode cable to the negative (-) stud, and work cable to the positive (+) stud).

The following recommendations apply to all output polarities and weld modes:

- **Select the appropriate size cables per the “Output Cable Guidelines” below.** Excessive voltage drops caused by undersized welding cables and poor connections often result in unsatisfactory welding performance. Always use the largest welding cables (electrode and work) that are practical, and be sure all connections are clean and tight.

Note: Excessive heat in the weld circuit indicates undersized cables and/or bad connections.

- **Route all cables directly to the work and wire feeder, avoid excessive lengths and do not coil excess cable.** Route the electrode and work cables in close proximity to one another to minimize the loop area and therefore the inductance of the weld circuit.
- Always weld in a direction away from the work (ground) connection.

(See Table A.1)

Tabulated below are copper cable sizes recommended for different currents and duty cycles. Lengths stipulated are the distance from the welder to work and back to the welder again. Cable sizes are increased for greater lengths primarily for the purpose of minimizing voltage drop.

TABLE A.1

RECOMMENDED CABLE SIZES (RUBBER COVERED COPPER - RATED 167°F OR 75°C)**						
Amperes	PERCENT DUTY CYCLE	CABLE SIZES FOR COMBINED LENGTHS OF ELECTRODE AND WORK CABLES				
		0 to 50Ft. (0 to 15m)	50 to 100Ft. (15 to 30m)	100 to 150 Ft. (30 to 46m)	150 to 200 Ft. (46 to 61m)	200 to 250 Ft. (61 to 76m)
200	60	2	2	2	1	1/0
200	100	2	2	2	1	1/0
225	20	4 or 5	3	4 or 5	1	1/0
225	40 & 30	3	3	3	1	1/0
250	30	3	3	3	1	1/0
250	40	2	2	2	1	1/0
250	60	1	1	1	1	1/0
250	100	1	1	1	1	1/0
300	60	1	1	1	1/0	1/0
350	100	2/0	2/0	2/0	2/0	2/0
350	60	1/0	1/0	1/0	2/0	3/0
400	60	2/0	2/0	2/0	3/0	4/0
400	100	3/0	3/0	3/0	3/0	4/0
500	60	2/0	2/0	2/0	3/0	4/0

** Tabled values are for operation at ambient temperatures of 104°F(40°C) and below. Applications above 104°F(40°C) may require cables larger than recommended, or cables rated higher than 167°F(75°C).

REMOTE SENSE LEAD SPECIFICATIONS

Genuine Lincoln Electric control cables should be used at all times (except where noted otherwise). Lincoln Electric cables are specifically designed for the communication and power needs of the Flextec 350XP. Most are designed to be connected end-to-end for ease of extension. Generally, it is recommended that the total length not exceed 100 feet (30.5 m). The use of non-standard cables, especially in lengths greater than 25 feet, can lead to communication problems (system shutdowns), poor motor acceleration (poor arc starting), and low wire driving force (wire feeding problems). Always use the shortest length of control cable possible, and DO NOT coil excess cable.

Regarding cable placement, best results will be obtained when control cables are routed separate from the weld cables. This minimizes the possibility of interference between the high currents flowing through the weld cables, and the low level signals in the control cables.

Paralleling Machines

The Flextec 350XP power sources may be paralleled for increased output requirements in constant current application. No kit is required for paralleling of Flextec 350XP power sources. The Flextec 350XP can only be paralleled for constant current processes. Connect the power sources as shown, and set the output control of each power sources to one half of the desired arc current.

Figure A.2

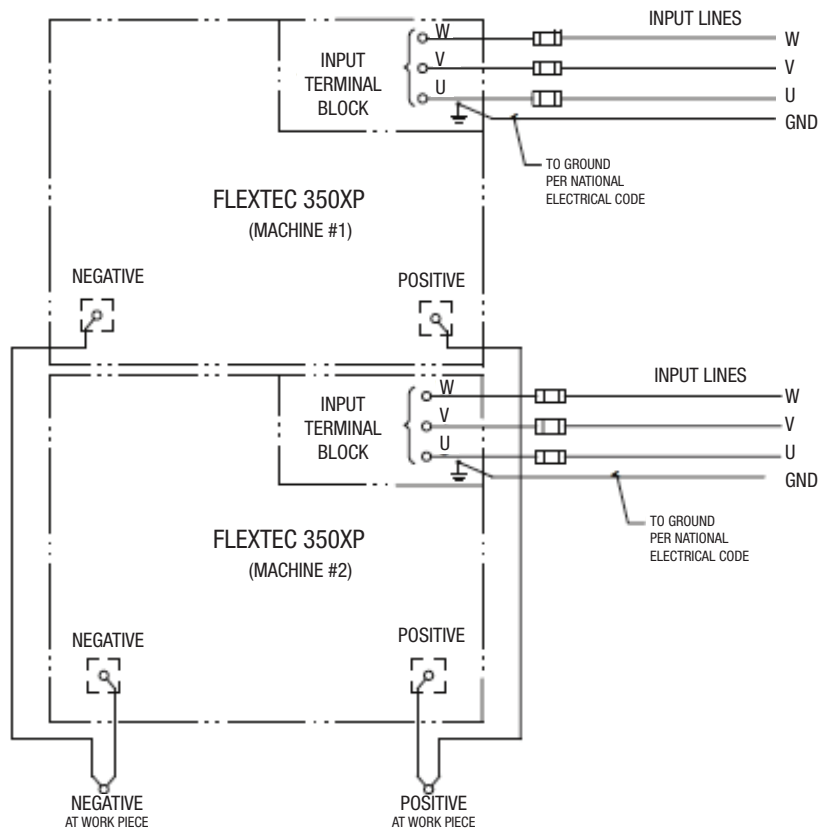

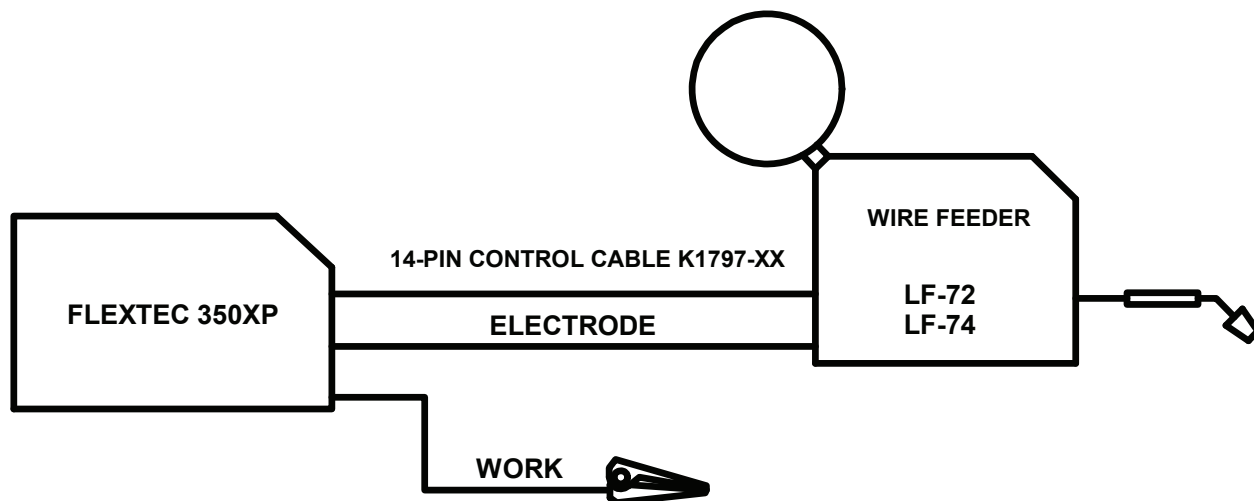

CONNECTING LF-72 AND LF-74 TO THE FLEXTEC 350XP

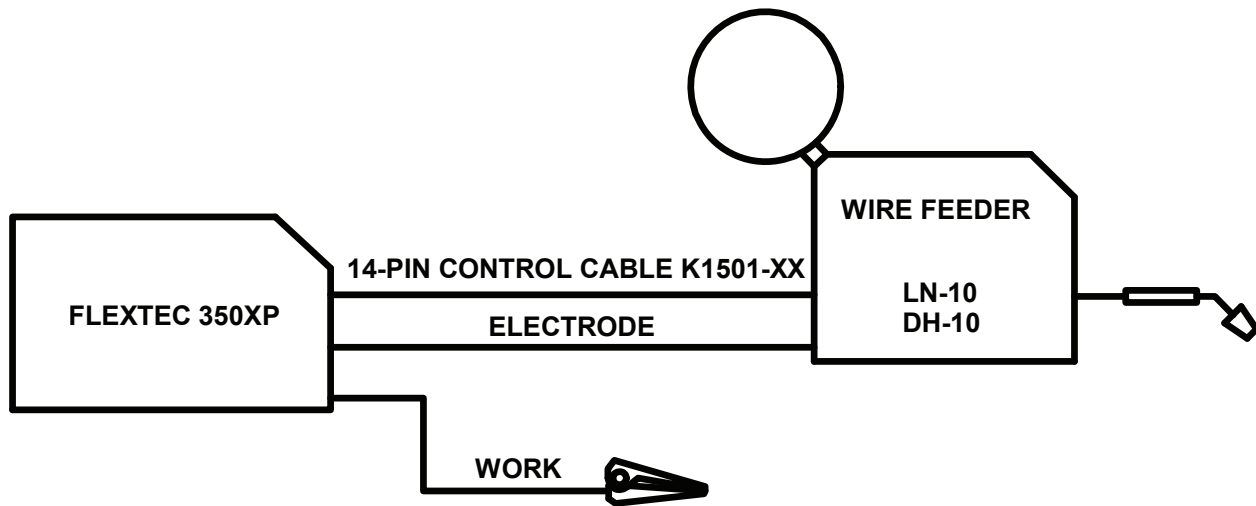

CONTROL SETTING	
WELD MODE	CV, CV-INNERSHIELD
WELD TERMINALS	REMOTELY CONTROLLED <input checked="" type="checkbox"/>
REMOTE/LOCAL	LOCAL
	(REMOTE IF K2329-1 INSTALLED)
VOLTMETER POLARITY	PROCESS DEPENDENT

CONNECTING LN-10 AND DH-10 TO THE FLEXTEC 350XP



CONTROL SETTING	
WELD MODE	CV, CV-INNERSHIELD
WELD TERMINALS	REMOTELY CONTROLLED 
REMOTE/LOCAL	REMOTE
VOLTMETER POLARITY	PROCESS DEPENDENT

LN-10, DH-10 Control Switch Setup

Initial set up of the LN-10, DH-10 control for the system components being used and for general operator preferences is done using a pair of 8-pole DIP switches located inside the LN-10, DH-10 control box.

Setting the DIP Switches

The DIP switches are each labeled with an “ON” arrow showing the on direction for each of the 8 individual switches in each DIP switch (S1 and S2). The functions of these switches are also labeled and set as described below:

Setup DIP Switch Access

- 1) Shut off the input power to the LN-10, DH-10 control by turning off the power at the welding power source it is connected to.
- 2) Remove the two screws on the top of the LN-10, DH-10 control box door and swing the door down to open.
- 3) Locate the two 8-pole DIP switches, near the top left corner of the LN-10, DH-10 Control P.C. board, labeled S1 and S2.
- 4) Switch settings are only programmed during input power-up restoration.



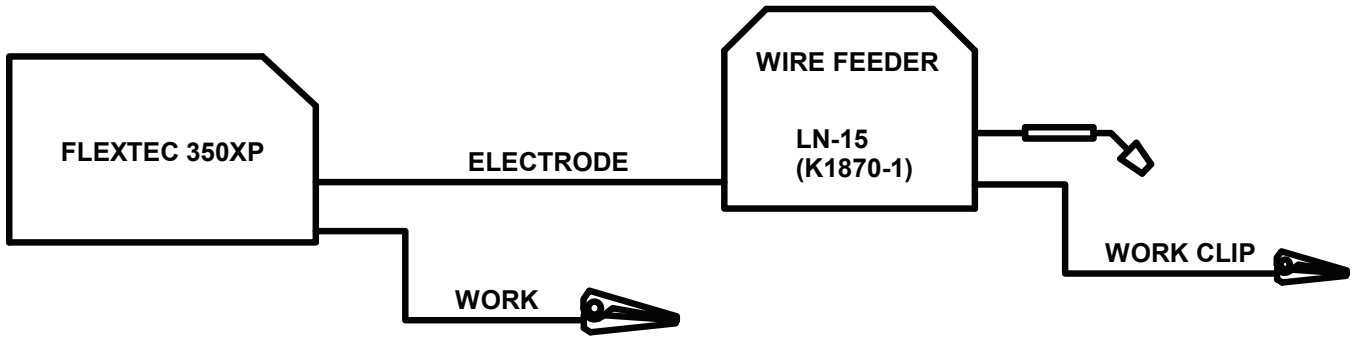

CONNECTING LN-15 (K1870-1) TO THE FLEXTEC 350XP

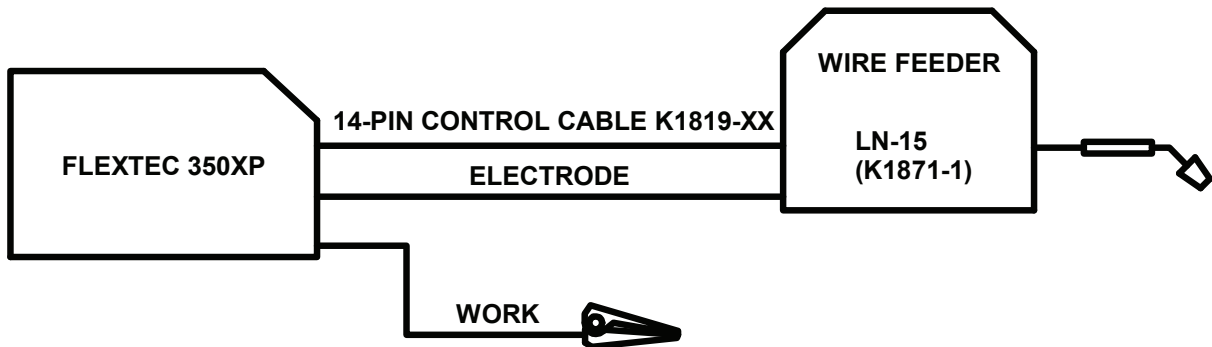

CONTROL SETTING	
WELD MODE	CV, CV-INNERSHIELD
WELD TERMINALS	ON
REMOTE/LOCAL	LOCAL
VOLTMETER POLARITY	PROCESS DEPENDENT

CONNECTING LN-15 (K1871-1) TO THE FLEXTEC 350XP



CONTROL SETTING	
WELD MODE	CV, CV-INNERSHIELD
WELD TERMINALS	REMOTELY CONTROLLED 
REMOTE/LOCAL	REMOTE
VOLTMETER POLARITY	PROCESS DEPENDENT

CONNECTING ACTIV8, ACTIV8X, LN-25 PRO SERIES, LN-25 PIPE, LN-25 IRONWORK AND LN-25X TO THE FLEXTEC 350XP

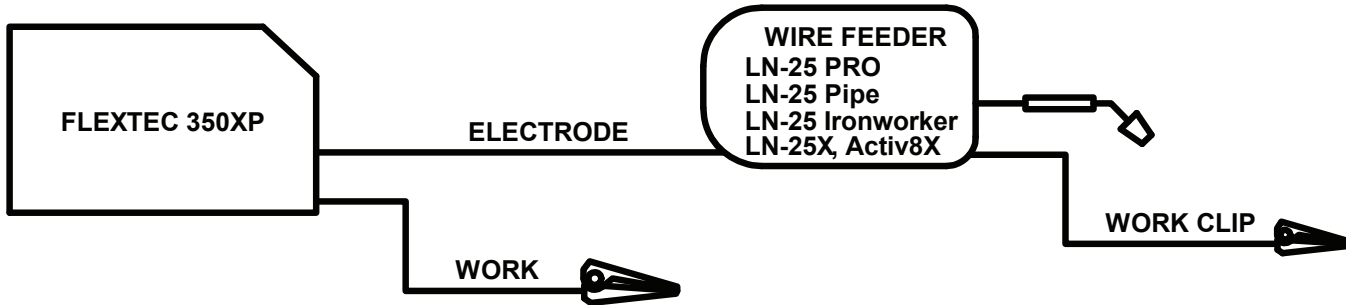

CONTROL SETTING	
WELD MODE	CV, CV-INNERSHIELD
WELD TERMINALS	ON
REMOTE/LOCAL	LOCAL, OR REMOTE WHEN USING CROSSLINC
VOLTMETER POLARITY	PROCESS DEPENDENT

CONNECTING LN-25 PRO DUAL POWER TO THE FLEXTEC 350XP

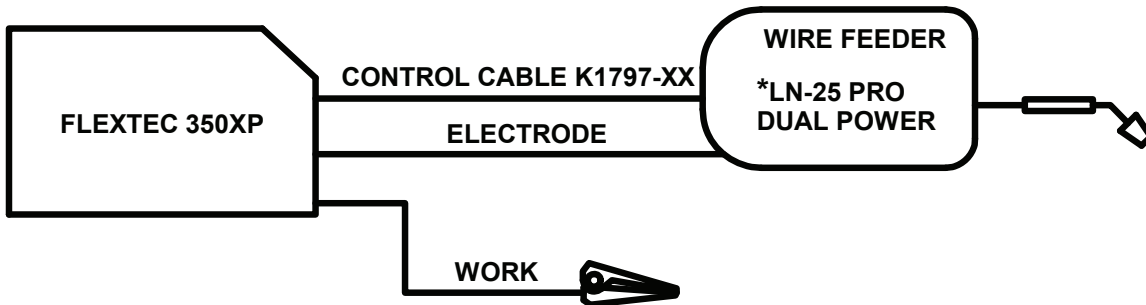

CONTROL SETTING	
WELD MODE	CV, CV-INNERSHIELD
WELD TERMINALS	REMOTELY CONTROLLED 
REMOTE/LOCAL	REMOTE
VOLTMETER POLARITY	PROCESS DEPENDENT

*CONTROL CABLE SETUP SHOWN. REFER TO LN-25 PRO CONNECTION DIAGRAM IF SETTING UP "ACROSS-THE-ARC" FEEDER.

CONNECTING ARCLINK FEEDER TO THE FLEXTEC 350XP

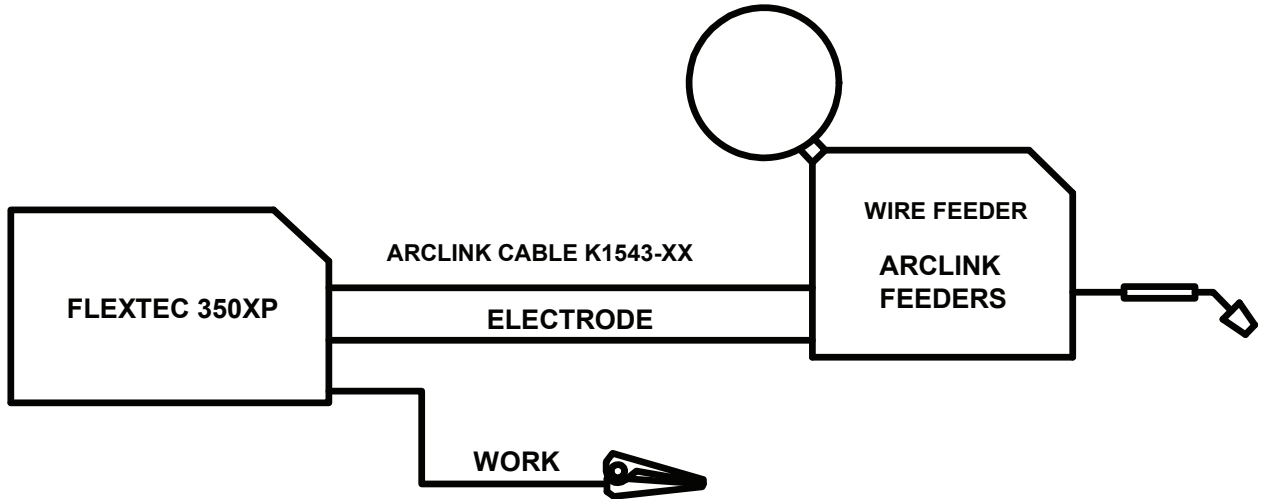

CONTROL SETTING	
WELD MODE	ARCLINK
WELD TERMINALS	REMOTE
REMOTE/LOCAL	N.A.
	N.A.
VOLTMETER POLARITY	N.A.

CONNECTING ACTIV8X PIPE TO FLEXTEC 350XP CE

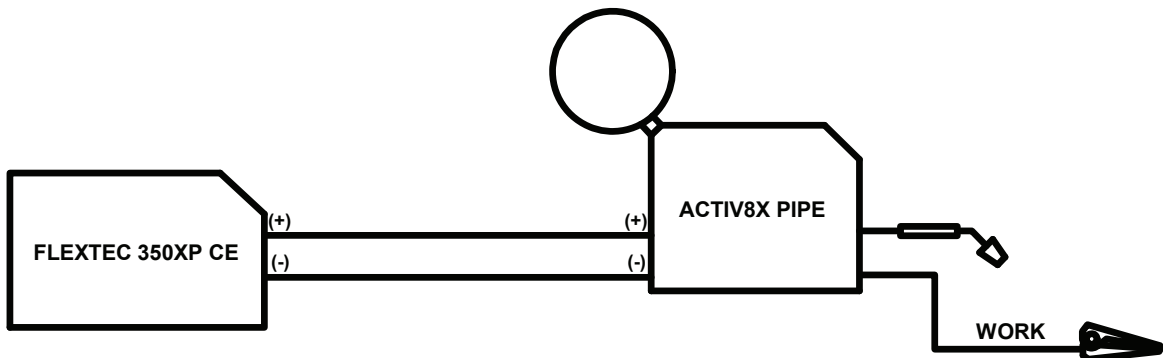

CONTROL SETTING	
WELD MODE	NOT ARCLINK OR TIG
WELD TERMINALS	ON
REMOTE/LOCAL	N.A.
	N.A.
VOLTMETER POLARITY	N.A.

OPERATION

SAFETY PRECAUTIONS

WARNING

ELECTRIC SHOCK can kill.

- UNLESS USING COLD FEED FEATURE, WHEN FEEDING WITH GUN TRIGGER, THE ELECTRODE AND DRIVE MECHANISM ARE ALWAYS ELECTRICALLY ENERGIZED AND COULD REMAIN ENERGIZED SEVERAL SECONDS AFTER THE WELDING CEASES.



FUMES AND GASES can be dangerous.

- Keep your head out of fumes.
- Use ventilation or exhaust to remove fumes from breathing zone.



ARC RAYS can burn.

- Wear eye, ear and body protection.



SEE ADDITIONAL WARNING INFORMATION UNDER "ARC WELDING SAFETY PRECAUTIONS" ON INSIDE OF FRONT COVER OF OPERATING MANUAL.

GRAPHIC SYMBOLS THAT APPEAR ON THE Flextec® 350XP OR IN THIS MANUAL



INPUT POWER



ON



OFF



HIGH TEMPERATURE



CIRCUIT BREAKER



WIRE FEEDER



POSITIVE OUTPUT



NEGATIVE OUTPUT



3 PHASE INVERTER



INPUT POWER



THREE PHASE



DIRECT CURRENT

U_r

REDUCED OPEN CIRCUIT VOLTAGE

U_0

OPEN CIRCUIT VOLTAGE

U_1

INPUT VOLTAGE

U_2

OUTPUT VOLTAGE

I_1

INPUT CURRENT

I_2

OUTPUT CURRENT



PROTECTIVE GROUND



WARNING or CAUTION



Explosion



Dangerous Voltage



Shock Hazard

POWER-UP SEQUENCE

When power is applied to the Flextec 350XP, the displays will illuminate and the machine electronics will complete a power up sequence indicated by a scrolling bar across each seven segment display. Once the power up sequence is complete and the machine is ready for welding, the seven segment displays will indicate the voltage and amperage settings. Any ArcLink wire feeders present and connected to the 5-pin circular connector will also initialize and begin a power up sequence once power is applied to the machine.

For machines connected to CrossLinc® compatible feeders the green CrossLinc® will light indicating a connection to the feeder over the electrode cable.

DUTY CYCLE

The Flextec 350XP is capable of welding at a 100% duty cycle (continuous welding) at 300 Amps rated output.

The 60% duty cycle rating is 350 amps (based off of a ten minute cycle – 6 minutes on time and 4 minutes off time). The maximum output of the machine is 425 amps.

The Flextec 350XP is also rated for Desert Duty, elevated temperature operation, in a 55°C ambient. The machine is derated in the elevated temperature ambient.

THERMAL PROTECTION

Thermostats protect the machine from excessive operating temperatures. Excessive temperatures may be caused by a lack of cooling air or operating the machine beyond the duty cycle and output rating. If excessive operating temperature should occur, the thermostat will disable the output and run the cooling fan. The displays will remain energized during this time and the thermal light will be illuminated. Thermostats are self-resetting once the machine cools sufficiently. If the thermostat shutdown was caused by excessive output or duty cycle and the fan is operating normally, the Power Switch may be left on and the reset should occur within a 15 minute period.

For FT350XP Construction machines the welding output will start again as soon as the thermostats close.

The FT350XP Standard output will start again if the welding output controls are set to on. Otherwise the output will be started once the controls are enabled.

MAKING A WELD

The Flextec 350XP is a multi-process inverter welder. The Weld Process Selector Switch is used to set the desired weld mode. The Flextec 350XP Standard has 4 selectable welding modes:

1. **GTAW** – This is a CC (constant current) weld mode used for touch start GTAW tig welding process.
2. **SMAW** – This is a CC (constant current) weld mode used for the SMAW stick welding process.
3. **CV** – This is CV (constant voltage) weld mode used for welding the GMAW mig welding process and the FCAW-GS, flux cored gas shielded welding process.
4. **CV-Innershield** – This is a CV (constant voltage) weld mode used for welding the FCAW-SS, flux cored self shielded welding process

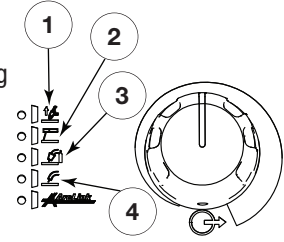

(Not pictured/ArcLink - is the digital communications channel. This uses the 5-pin amphenol. Pulsed MIG is only available using an ArcLink feeder connected to the 5-pin amphenol. **Only available in Flextec 350XP model).**

The machine is also capable of gouging. Gouging can be done in either the SMAW mode or the CV and CV-Innershield modes.

In addition to the Weld Mode Selector switch, a hot start dial, output control dial and arc control dial are provided to setup and fine tune the welding procedure.

DEFINITION OF WELDING MODES

NON-SYNERGIC WELDING MODES

- A Non-synergic welding mode requires all welding process variables to be set by the operator.

SYNERGIC WELDING MODES

- A Synergic welding mode offers the simplicity of single knob control. The machine will select the correct voltage and amperage based on the wire feed speed (WFS) set by the operator.

WELD CONTROLS AND DISPLAYS

Weld Process Selector Switch

5 or 4 Position switch used to select the welding process.

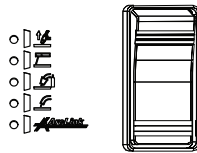

Hot Start Dial

The Hot Start control regulates the starting current at arc initiation. Hot Start can be set to '0' and no additional current is added at arc start. Increasing from 0 to 10 will increase the additional current (relative to the preset current) that is added at arc initiation.

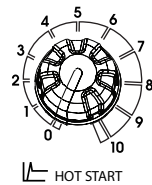

Arc Force Control Dial

Full range selection of arc control from -10 to +10. In CV mode, this control is an inductance control. In stick mode, the control adjusts the arc force.

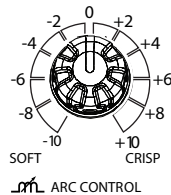

Output Control Dial

Output control is conducted via a single turn potentiometer.

Adjustment is indicated by the meters.

When in remote modes, this control sets the maximum welding current or voltage output. Full depression of a foot or hand amptrol results in the preset level of current or voltage.

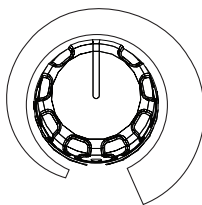

* Not included on Construction model.

Volt Display Meter

- Prior to CV operation (current flow), the meter displays desired preset voltage value (+/- .1V).
- Prior to STICK or TIG operation, the meter displays three dashes.
- During welding, this meter displays actual average volts.
- After welding, the meter holds the actual voltage value for 5 seconds. The displays blink indicating that the machine is in the "Hold" period.
- Output adjustment while in the "hold" period results in the "prior to operation" characteristics.



Amperage Display Meter

- Prior to STICK or TIG operation (current flow), the meter displays preset current value.
- Prior to CV operation, the meter displays four dashes indicating non-presetable AMPS.
- During welding, this meter displays actual average amps.
- After welding, the meter holds the actual current value for 5 seconds. The displays blink indicating that the machine is in the "Hold" period.
- Output adjustment while in the "hold" period results in the "prior to operation" characteristics

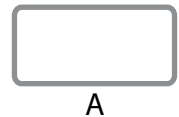

Weld Terminals On/Remote Toggle Switch *

- This switch determines the trigger location.
- When set to the 'ON' position, the weld terminals are at OCV (open circuit voltage) and ready to weld.
- When set to the 'remote' position, output is enabled through a remote trigger such as a welding gun.

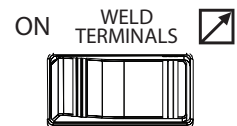

Output Control - Local/Remote Toggle Switch

- Set the switch to 'local' to control output at the Flextec via the Output Control dial.
- Set the switch to 'remote' to control output via a remote device (K857 hand amptrol or K870 foot amptrol) connected to the 12-pin remote connector or a wire feeder connected to the 14-pin connector or when using a CrossLinc® enabled wire feeder.

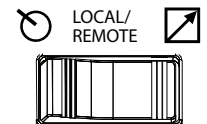

Wire Feeder Voltmeter Polarity Switch *

This switch configures the 21 sense lead in the 14 pin connector to the work weld terminal of the machine. Matches the polarity of the wire feeder voltmeter to the polarity of the electrode. It also configures the reading of the 67 sense lead when in ArcLink mode.

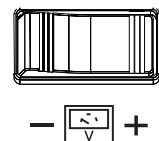

Thermal Light

This status light indicates when the power source has been driven into thermal overload. If the output terminals were "ON", the output will be turned back on once the unit cools down to an acceptable temperature level. If the unit was operating in the "REMOTE" mode, the trigger will need to be opened before or after the thermal has cleared and closed after the machine has cooled down to an acceptable temperature to re-establish output.



VRD Lights

There are two indicator lights on the case front of the Flextec 350XP above the Voltage display to indicate the status of VRD operation. As shipped, the VRD function is disabled. VRD is enabled by setting dip switch number 5 to the on position on the User Interface P.C. board. When VRD is active, a green light indicates the open circuit voltage is less than 35V peak, a red light indicates the OCV is at or above 35V peak, both lights will illuminate for 5 seconds upon power up. The behavior of the VRD lights is listed in the table below. While the VRD lights are always active when VRD has been enabled, VRD applies to the constant current modes of operation. Only in these modes will the OCV been reduced.

VRD™



TABLE B.1

VRD INDICATOR LIGHTS			
MODE		VRD "ON"	VRD "OFF"
CC-SMAW CC-GTAW	OCV	GREEN (OCV REDUCED)	NO LIGHTS ARE ACTIVE
	WHILE WELDING	GREEN OR RED (DEPENDS ON WELD VOLTAGE)*	
CV-GAS C V-INNERSHIELD	OCV	RED (OCV NOT REDUCED) WELD TERMINALS 'ON'	
		RED (OCV NOT REDUCED) WELD TERMINALS REMOTELY CONTROLLED GUN TRIGGER CLOSED	
		GREEN (NO OCV) WELD TERMINALS REMOTELY CONTROLLED GUN TRIGGER OPEN	
	WHILE WELDING	GREEN OR RED (DEPENDS ON WELD VOLTAGE)*	

* It is normal for the lights to alternate between colors while welding.

BASIC MODES OF OPERATION

GTAW

This weld mode is a constant current (CC) mode featuring continuous control from 10 –425 amps.

It is intended for the GTAW TIG welding processes.

Hot Start - Hot start regulates the arc initiation current. A setting of +10 results in the most positive arc initiation.

Arc Control – This control is not used in the GTAW mode.

Weld Terminals On/Remote

- When set to the 'ON' position, the weld terminals are at OCV (open circuit voltage) and ready to weld.
- When set to the 'remote' position, output is enabled through a remote trigger.

Voltage Display – This display will display three dashed lines when the machine is in the idle state. This indicates that voltage is not settable in this weld mode. While output is enabled, the actual welding voltage will be displayed. After welding, the meter holds the actual voltage value for 5 seconds. Output adjustment while in the "hold" period results in the "prior to operation" characteristics stated above. The displays blink indicating that the machine is in the "Hold" period.

Amperage Display – This display will display the pre-set welding current when the machine is in the idle state. After welding, the meter holds the actual amperage value for 5 seconds. Output adjustment while in the "hold" period results in the "prior to operation" characteristics stated above. The displays blink indicating that the machine is in the "Hold" period.

Output Control Local/Remote – When the control is set to local (no remote potentiometer/control plugged into the 12-pin or 14-pin connectors), the output is controlled through the Output Control dial on the front of the Flextec 350XP. Set this switch to 'Remote' when an external potentiometer/control is connected.

- o When a remote potentiometer is connected and the Local/Remote toggle is set to 'Remote', the output control on the Flextec and the remote act as a master/slave configuration. Use the output control dial on the Flextec to set the maximum welding current. The remote will control output from minimum to the pre-set maximum.

Output Control Dial

- o When the Local/Remote is set to Local, this dial sets the welding amperage.
- o When the Local/Remote is set to Remote, this dial sets the maximum welding amperage. The remote potentiometer than controls the amperage from minimum to this pre-set maximum.

FIGURE B.1

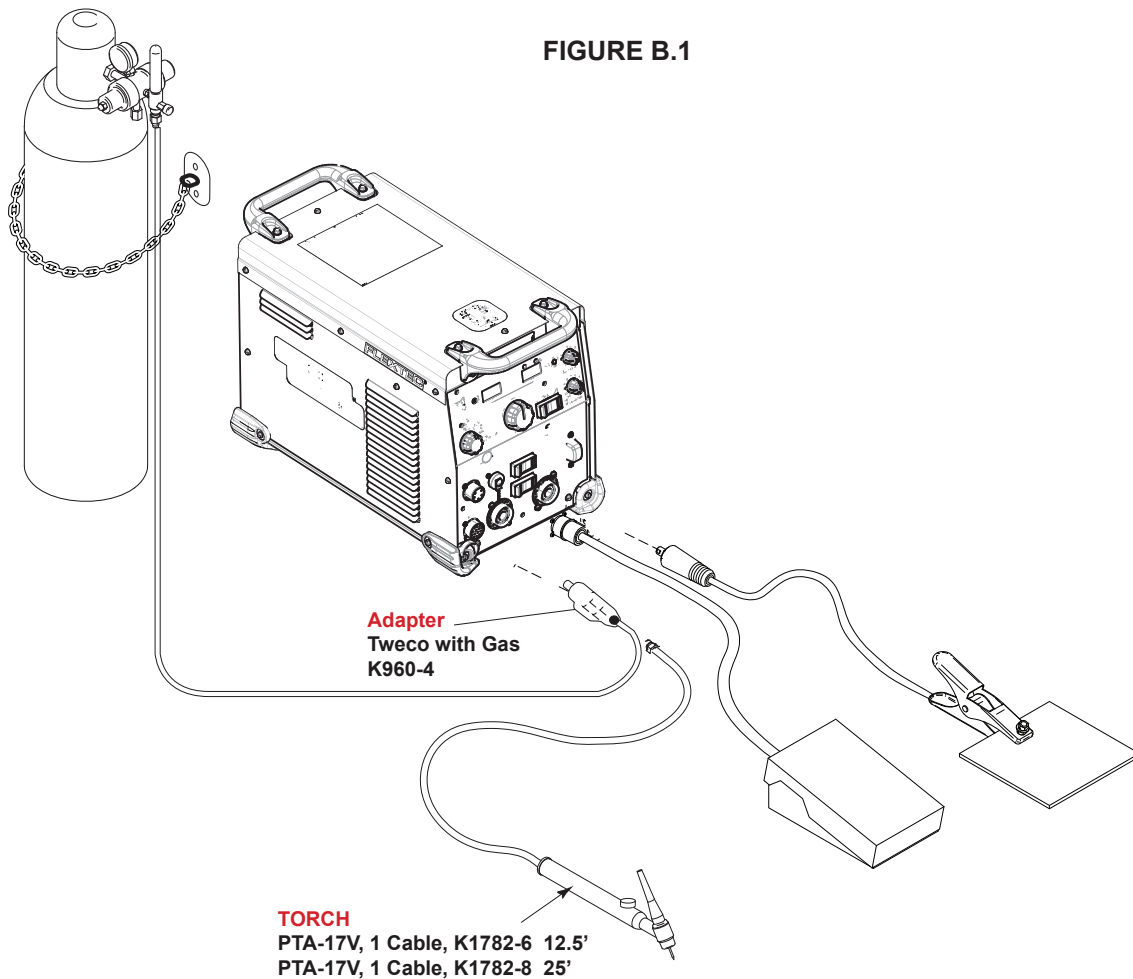

SMAW

This weld mode is a constant current (CC) mode featuring continuous control from 15 – 425 Amps.

It is intended for the SMAW stick welding processes and arc gouging. The mode can also be used for TIG operation without changing modes (as long as Hot Start=0 and Arc Control=(-10). Values of Hot start greater than 0 will result in a higher current arc start. Values of Arc Control greater than the minimum setting of (-10) will result in a higher output than the intended preset value.)

Hot Start - The Hot Start control regulates the starting current at arc initiation. Hot Start can be set to '0' and no additional current is added at arc start. Increasing from 0 to 10 will increase the additional current (relative to the preset current) that is added at arc initiation.

Arc Control - The Arc Control regulates the Arc Force to adjust the short circuit current. The minimum setting (-10) will produce a "soft" arc and will produce minimal spatter and shallow penetration. The maximum setting (+10) will produce a "crisp" arc and will minimize electrode sticking with deeper penetration.

Weld Terminals On/Remote – Set to "On" so the machine is in the ready to weld state. Setting the machine to "On" enables the machine OCV.

Voltage Display – This display will display three dashed lines when the machine is in the idle state. This indicates that voltage is not settable in this weld mode. While output is enabled, the actual welding voltage will be displayed. After welding, the meter holds the actual voltage value for 5 seconds. Output adjustment while in the "hold" period results in the "prior to operation" characteristics stated above. The displays blink indicating that the machine is in the "Hold" period.

Amperage Display – This display will display the pre-set welding current when the machine is in the idle state. After welding, the meter holds the actual amperage value for 5 seconds. Output adjustment while in the "hold" period results in the "prior to operation" characteristics stated above. The displays blink indicating that the machine is in the "Hold" period.

Output Control Local/Remote – When the control is set to local (no remote potentiometer/control plugged into the 12-pin or 14-pin connectors), the output is controlled through the Output Control dial on the front of the Flextec 350XP. Set this switch to 'Remote' when an external potentiometer/control is connected.

- When a remote potentiometer is connected, the output control on the Flextec and the remote act as a master/slave configuration. Use the output control dial on the Flextec to set the maximum welding current. The remote will control output from minimum to the pre-set maximum.

Output Control Dial

- When the Local/Remote is set to Local, this dial sets the welding amperage.
- When the Local/Remote is set to Remote, this dial sets the maximum welding amperage. The remote potentiometer then controls the amperage from minimum to this pre-set maximum.

FIGURE B.2

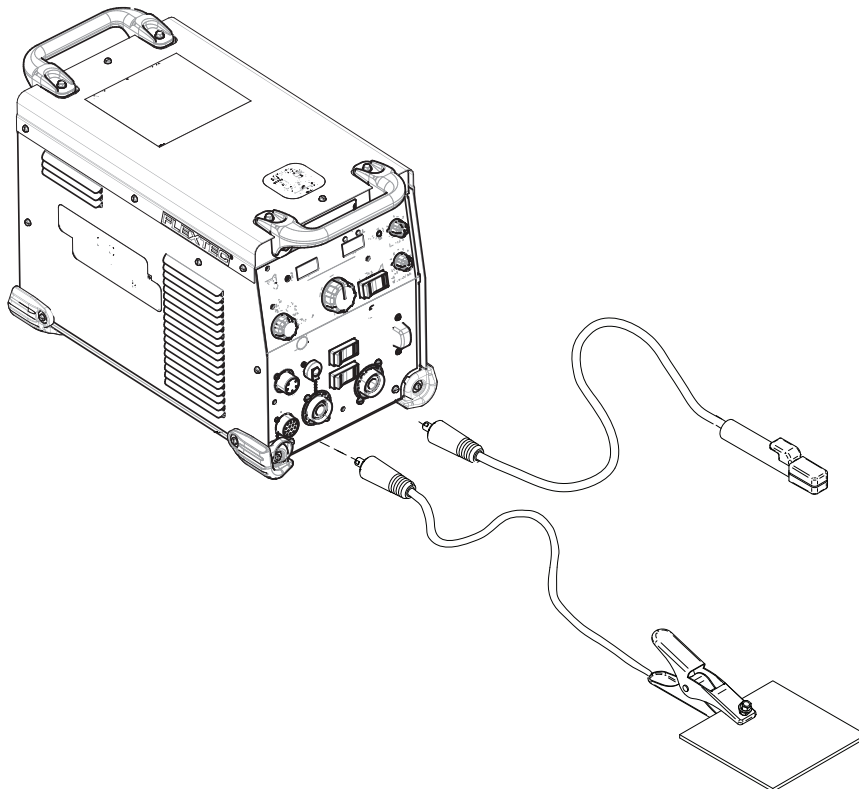

CV-Gas

This weld mode is a constant voltage (CV) mode featuring continuous control from 10 to 45 volts.

It is intended for the GMAW, FCAW-GS, MCAW welding processes and arc gouging.

Hot Start – Rotate from the '0' position to the '10' position to provide more energy during the start of a weld.

Arc Control – The Arc Control regulates pinch effect. At the minimum setting (-10), minimizes pinch and results in a soft arc. Low pinch settings are preferable for welding with gas mixes containing mostly inert gases as well as aluminum alloys. At the maximum setting (+10), maximizes pinch effect and results in a crisp arc. High pinch settings are preferable for welding FCAW and GMAW with CO₂.

Weld Terminals On/Remote

- When set to the 'ON' position, the weld terminals are at OCV (open circuit voltage) and ready to weld. This selection is used for across the arc wire feeders. The 12-pin connector remote input is used to adjust the voltage with a master/slave relationship with the output control dial.
- When set to the 'remote' position, output is enabled through a remote trigger. The 14-pin connector remote input is used to adjust the voltage with a master/slave relationship with the output control dial.

Amperage Display – This display will display three dashed lines when the machine is in the idle state. This indicates that amperage is not settable in this weld mode. While output is enabled, the actual welding amperage will be displayed. After welding, the meter holds the actual amperage value for 5 seconds. Output adjustment while in the "hold" period results in the "prior to operation" characteristics stated above. The displays blink indicating that the machine is in the "Hold" period.

Voltage Display – This display will display the pre-set welding voltage when the machine is in the idle state. After welding, the meter holds the actual voltage value for 5 seconds. Output adjustment while in the "hold" period results in the "prior to operation" characteristics stated above. The displays blink indicating that the machine is in the "Hold" period.

Output Control Local/Remote – When the control is set to local (no remote potentiometer/control plugged into the 12-pin or 14-pin connectors), the output is controlled through the Output Control dial on the front of the Flextec 350XP. Set this switch to 'Remote' when an external potentiometer/control is connected or using a CrossLinc® feeder.

- When a CrossLinc® equipped feeder like the LN-25X is used, output will then be controlled at the CrossLinc remote through the full range of the voltage allowable. The output control dial on the Flextec 350XP will no longer set the maximum amperage.

Output Control Dial

- o When the Local/Remote is set to Local, this dial sets the welding voltage.
- o When the Local/Remote is set to Remote, and the weld terminal switch is in the 'ON' position, this dial sets the maximum welding voltage. The remote potentiometer controls the voltage from minimum to this pre-set maximum. If the weld terminal switch is in the 'REMOTE' position, the output is controlled via the 14-pin input.

FIGURE B.3

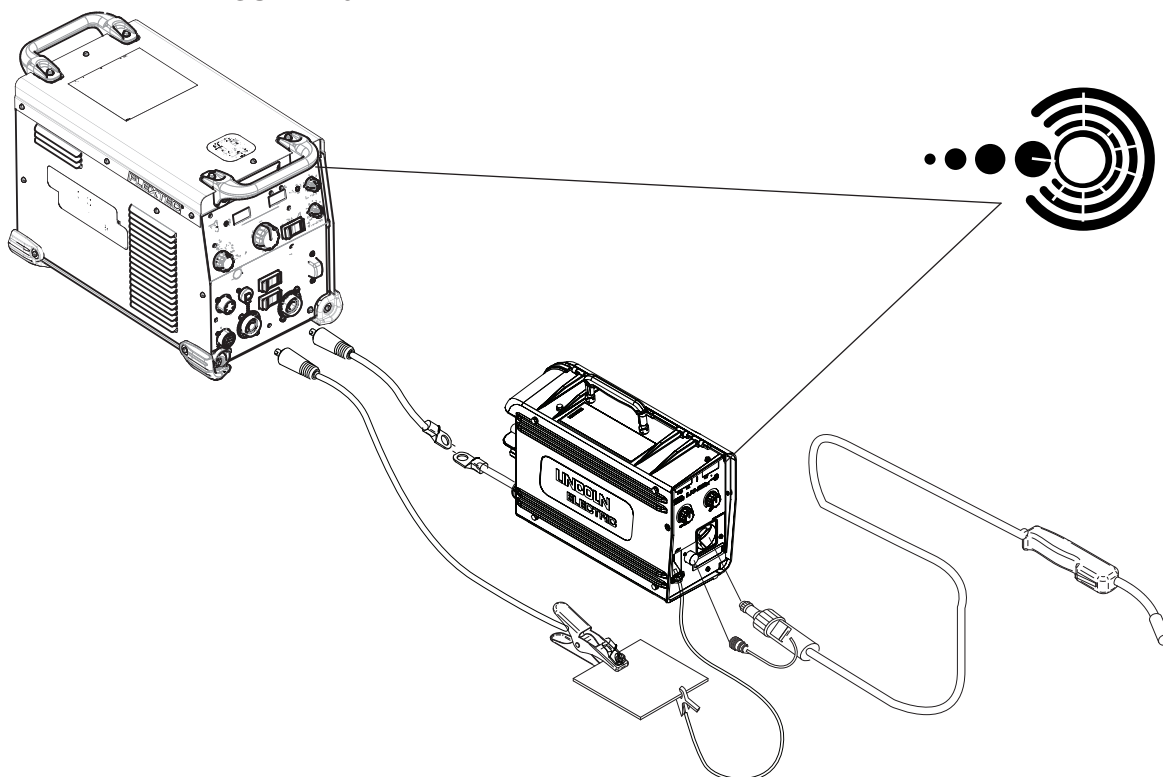

CrossLinc® - CrossLinc is a new welding system communication technology. When using a CrossLinc enabled power source such as the Flextec 350XP and a CrossLinc enabled wire feeder such as the LN-25X, welding voltage can be controlled remotely without the use of an additional control cable.

The digital meters on the LN-25X will show the pre-set values for wire feed speed and voltage prior to welding. During welding, the meters will show actual current and voltage present at the wire feeder. After welding the meters will then flash the last welding current and voltage that was present during welding for 10-seconds after welding. If WFS or V is adjusted during this 10 second period, the meters will go back to the pre-set value.

- When a LN-25X CrossLinc enabled feeder is connected with the Flextec 350XP using the standard weld power cable and the LN-25X sense lead is attached to the work piece, the CrossLinc light will automatically illuminate on both the Flextec 350XP and the LN-25X. No additional pairing of the machine to the feeder is needed. This light indicates the CrossLinc connection is active and that control of the Flextec 350XP voltage can be made at the LN-25X feeder.
- The Flextec 350XP Weld Terminals On/Remote toggle should be set to 'ON'. This powers the weld terminals for an across-the-arc LN-25X wire feeder.
- The Flextec 350XP Output Control Local/Remote switch should be set to 'Remote' allowing for remote control of the output at the CrossLinc equipped feeder.

CV-Innershield

This weld mode is a constant voltage (CV) mode featuring continuous control from 10 to 45 volts.

It is intended for the FCAW-SS welding process and arc gouging.

Hot Start – Toggle from the '0' position to the '10' position to provide more energy during the start of a weld.

Arc Control – The Arc Control regulates pinch effect. At the minimum setting (-10), minimizes pinch and results in a soft arc. At the maximum setting (+10), maximizes pinch effect and results in a crisp arc.

Weld Terminals On/Remote

- When set to the 'ON' position, the weld terminals are at OCV (open circuit voltage) and ready to weld. This selection is used for across the arc wire feeders. The 12-pin connector remote input is used to adjust the voltage with a master/slave relationship with the output control dial.
- When set to the 'remote' position, output is enabled through a remote trigger. The 14-pin connector remote input is used to adjust the voltage with a master/slave relationship with the output control dial.

Amperage Display – This display will display three dashed lines when the machine is in the idle state. This indicates that amperage is not settable in this weld mode. While output is enabled, the actual welding amperage will be displayed. After welding, the meter holds the actual amperage value for 5 seconds. Output adjustment while in the "hold" period results in the "prior to operation" characteristics stated above. The displays blink indicating that the machine is in the "Hold" period.

Voltage Display – This display will display the pre-set welding voltage when the machine is in the idle state. After welding, the meter holds the actual voltage value for 5 seconds. Output adjustment while in the "hold" period results in the "prior to operation" characteristics stated above. The displays blink indicating that the machine is in the "Hold" period.

Output Control Local/Remote – When the control is set to local (no remote potentiometer/control plugged into the 12-pin or 14-pin connectors), the output is controlled through the Output Control dial on the front of the Flextec 350XP. Set this switch to 'Remote' when an external potentiometer/control is connected or using a CrossLinc® feeder.

Output Control Dial

- o When the Local/Remote is set to Local, this dial sets the welding voltage.
- o When the Local/Remote is set to Remote, and the weld terminal switch is in the 'ON' position, this dial sets the maximum welding voltage. The remote potentiometer controls the voltage from minimum to this pre-set maximum. If the weld terminal switch is in the 'REMOTE' position, the output is controlled via the 14-pin input.

ArcLink

This weld mode is intended to unlock basic non-synergic, synergic and pulse modes intended for use with compatible ArcLink wire feeders. All of the Flextec 350XP user interface controls are disabled in this mode and controlling the power source is accomplished from the wire feeder user interface.

Hot Start – Not used for this welding process

Arc Control – Not used for this welding process

Weld Terminals On/Remote

- Not used for this welding process
- Not used for this welding process

Output Control Local/Remote – Not used for this welding process

Output Control Dial

- o Not used for this welding process
- o Not used for this welding process

ECO Mode

ECO Mode is the idle power saving state that the Flextec 350XP CE enters when it has been inactive for 1 hour. The machine will operate at less than 50W power and wait until the mode selection switch is pressed to awaken. When ECO Mode is active the Flextec 350XP CE's weld and auxiliary power outputs are disabled. The machine will also display "ECO" on the left display, dashes on the right display, and the mode select LEDs will cycle. In order to exit ECO Mode the process select rocker switch on the Flextec 350XP CE's Casefront needs to be pressed. After approximately 5 seconds normal operation of the power source will resume and ECO Mode will not be entered until another hour of inactivity is detected.

CrossLinc®

CrossLinc is a new welding system communication technology. When using a CrossLinc enabled power source such as the Flextec 350XP and a CrossLinc enabled wire feeder such as the LN-25X, welding voltage can be controlled remotely without the use of an additional control cable.

The digital meters on the LN-25X will show the pre-set values for wire feed speed and voltage prior to welding. During welding, the meters will show actual current and voltage present at the wire current and voltage that was present during welding for 10-seconds after welding. If WFS or V is adjusted during this 10 second period, the meters will go back to the pre-set value.

- When a LN-25X CrossLinc enabled feeder is connected with the Flextec 350XP using the standard weld power cable and the LN-25X sense lead is attached to the work piece, the CrossLinc light will automatically illuminate on both the Flextec 350XP and the LN-25X. No additional pairing of the machine to the feeder is needed. This light indicates the CrossLinc connection is active and that control of the Flextec 350XP voltage can be made at the LN-25X feeder.
- The Flextec 350XP Weld Terminals On/Remote toggle should be set to 'ON'. This powers the weld terminals for an across-the-arc LN-25X wire feeder.
- The Flextec 350XP Output Control Local/Remote switch should be set to 'Remote' allowing for remote control of the output at the CrossLinc equipped feeder.

Process Selection Assist (Codes 13461 and Higher Only)

When using an Activ8x or LN-25X*, the Flextec will automatically select the process reflected by the polarity of the feeder. For instance, the process selected by the Flextec will automatically change to "CV" when connected electrode positive and "CV-Innershield" when connected electrode negative. The original process selected will blink on the Flextec until the CrossLinc connection is established.

When using a CrossLinc Remote*, the Flextec will automatically select the process reflected by the polarity of the remote. For instance, the process selected by the Flextec will automatically change to "SMAW" when connected electrode positive and "GTAW" mode when connected electrode negative. The original process selected will blink on the Flextec until the negotiation is completed.

The last process selected on the Flextec before connection through CrossLinc will be remembered by the power source. Upon power off of the CrossLinc Remote, Activ8X, or LN-25X by disconnecting the work clip, after a 30 second delay the selected process on the Flextec will revert to the originally selected process. Ten seconds after the power off of the feeder or remote, the original process that the Flextec will revert back to will begin to blink indicating to the user that an automatic change to the selected weld process is pending. If the power to the remote or feeder is turned off by the "weld terminals" switch on the front panel of the Flextec, the active process will revert back to the original process immediately without the delay.

The Process Selection Assist feature can be disabled or enabled using the process selection rocker switch. Holding the process selection rocker switch up for five seconds disables the process selection assist. The display will indicate this by showing "PSA" "OFF" for a couple seconds. Holding the process selection rocker switch in the up position for five seconds will enable the process selection assist. The display will indicate this by showing "PSA" "On" for a couple seconds.

When Process Selection Assist is active the process selection switch is disabled.

* Manufactured after December 2022

OPTIONAL KITS AND ACCESSORIES

K3059-4 Inverter and Wire Feeder Cart.* Rear-wheeled cart with front casters and gas bottle platform. Convenient handles allow for easy cable storage. Small footprint fits through 30 in. (762 mm) door. Not intended for use with double head wire feeders.



K3059-5 Dual Cylinder Inverter & Wire* Feeder Cart. Rear-wheeled cart with front casters and dual cylinder platform. Convenient handles allow for easy cable storage. Small footprint fits through 30 inch (762mm) door.



K3091-1 Multi-Process Switch.* Easily switch between CC and CV processes.



* Requires Locking Foot Kit (K4424-1)

K4424-1 Flextec 350 Locking Foot Kit Allows the Flextec to lock to the inverter cart, Multi-Process Switch, Cool-Arc 55 water cooler

K586-1 Deluxe Adjustable Gas Regulator & Hose Kit. Accommodates CO2, Argon, or Argon-blend gas cylinders. Includes a cylinder pressure gauge, dual scale flow gauge and 4.3ft (1.3m) gas hose.



3100211 Harris Argon Flowmeter Regulator and Hose Kit

K3019-1 Arc Tracker. The Arc Tracker monitors information regarding your welding arc by connecting it between any DC welding power source and the work clamp.



Weld Fume Control Solutions. Lincoln Electric offers a wide variety of welding fume control solutions, ranging from portable systems easily wheeled around the shop to shop-wide central systems servicing many dedicated welding stations.

K2909-1 12-pin to 6-pin Adapter



Stick Options

K857-2 12-pin Remote Output Control with Universal Connector. Permits remote adjustment of output.



TIG Options

K870-2 Foot Amptrol®. Provides 25 ft. (7.6 m) of remote current control for TIG welding (12-pin plug connection).



K963-4 Hand Amptrol® - Provides 25 ft. (7.6 m) of remote current control for TIG welding (12-pin plug connection).



K814 Arc Start Switch (6-pin) -** May be used in place of the Foot or Hand Amptrol®. Comes with a 25 ft. (7.6m) cable. Attaches to the TIG torch for convenient finger control to start and stop the weld cycle at the current set on the machine.



** Requires K2909-1 - 12-pin to 6-pin adapter

K4345-1 CrossLinc Remote - allows for remote output control of the Flextec power source through the weld cable without additional control cables.



MAINTENANCE

WARNING



Before carrying out service, maintenance and/or repair jobs, fully disconnect power to the machine.



Use Personal Protective Equipment (PPE), including safety glasses, dust mask and gloves to avoid injury. This also applies to persons who enter the work area.



MOVING PARTS can injure.

- Do not operate with doors open or guards off.
- Stop engine before servicing.
- Keep away from moving parts.



Have qualified personnel do all maintenance and troubleshooting work.

VISUAL INSPECTION

Clean interior of machine with a low pressure air stream. Make a thorough inspection of all components.

Look for signs of overheating, broken leads or other obvious problems. Many problems can be uncovered with a good visual inspection.

ROUTINE MAINTENANCE

Every six months the machine should be cleaned with a low pressure air stream. Keeping the machine clean will result in cooler operation and higher reliability. Be sure to clean the following areas:

- All printed circuit boards
- Power switch
- Main transformer
- Input rectifier
- Heatsink fins
- Auxiliary Transformer
- Fans (Blow air through the rear louvers)

Examine the sheet metal case for dents or breakage. Repair the case as required. Keep the case in good condition to ensure that high voltage parts are protected and correct spacing is maintained throughout. All external sheet metal screws must be in place to ensure case strength and electrical ground continuity.

CURRENT CALIBRATION

1. Connect the resistive load bank and test voltmeter to the welding output terminals.
2. Put dipswitch 1 in the on position.
3. Rotate the Hot Start knob and Arc Control knob to the minimum.
4. Turn on the Flextec 350XP.
5. The display should read "Cur CAL".
6. Rotate the Hot Start knob until a message scrolls across the screen.
7. Adjust the output control knob until the actual output amperage reading on the test ammeter is 300 amps +/- 2 amps.
8. Toggle the Local/Remote switch to save the calibration.
9. The display should flash "CAL SET".
10. Rotate the Hot Start knob to the minimum.
11. Rotate the Hot Start knob until a message scrolls across the screen.
12. Verify amperage reading on the test ammeter is 300 amps +/- 2 amps.
13. Repeat calibration steps starting from step 7 if necessary.

VOLTAGE CALIBRATION

1. Connect the resistive load bank and test voltmeter to the welding output terminals.
2. Put dipswitch 1 in the on position.
3. Rotate the Hot Start knob and Arc Control knob to the minimum.
4. Turn on the Flextec 350XP.
5. The display should read "Cur CAL".
6. Rotate the Arc Control knob until the display reads "VoL CAL".
7. Rotate the Hot Start knob until a message scrolls across the screen.
8. Adjust the output control knob until the actual output voltage reading on the test volt meter is 20 volts +/- .5 volts.
9. Toggle the Local/Remote switch to save the calibration.
10. The display should flash "CAL SET".
11. Rotate the Hot Start knob to the minimum.
12. Rotate the Hot Start knob until a message scrolls across the screen.
13. Verify voltage reading on the test volt meter is 20volts +/- .5 volts.
14. Repeat calibration steps starting from step 8 if necessary.



If for any reason you do not understand the procedures or are unable to perform the maintenance or repairs safely, contact your Lincoln Authorized Service Facility for technical troubleshooting assistance before you proceed.

WWW.LINCOLNELECTRIC.COM/LOCATOR

TO RESTORE FACTORY CURRENT CALIBRATION

1. Connect the resistive load bank and test voltmeter to the welding output terminals.
2. Put dipswitch 1 in the on position.
3. Rotate the Hot Start knob and Arc Control knob to the minimum.
4. Turn on the Flextec 350XP.
5. The display should read “Cur CAL”.
6. Rotate the Arc Control knob until the display reads “Fct Cur”.
7. Rotate the Hot Start knob until a message scrolls across the screen.
8. Toggle the Local/Remote switch to save the calibration.
9. The display should flash “CAL SET”.

TO RESTORE FACTORY VOLTAGE CALIBRATION

1. Connect the resistive load bank and test voltmeter to the welding output terminals.
2. Put dipswitch 1 in the on position.
3. Rotate the Hot Start knob and Arc Control knob to the minimum.
4. Turn on the Flextec 350XP.
5. The display should read “Cur CAL”.
6. Rotate the Arc Control knob until the display reads “Fct Vol”.
7. Rotate the Hot Start knob until a message scrolls across the screen.
8. Toggle the Local/Remote switch to save the calibration.
9. The display should flash “CAL SET”.

TO REPLACE INPUT CORD

1. Completely de-energize machine and verify that no residual charge is present on capacitors, etc.
2. Remove case sides to expose input cord connection to input EMI Filter. **See FIGURE D.1.**

FIGURE D.1

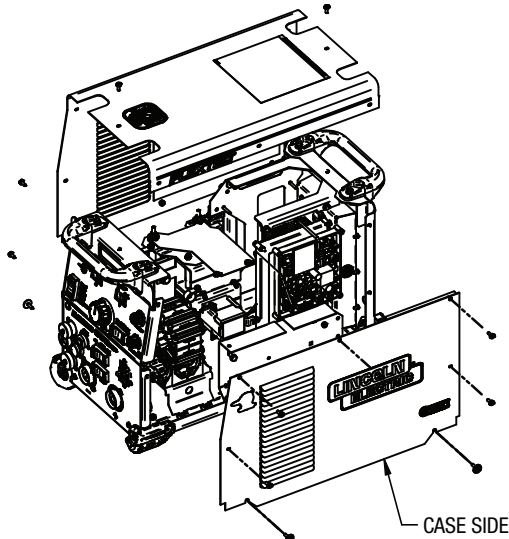

3. Remove 2 fasteners holding filter bracket to case bottom. **See FIGURE D.2.**

FIGURE D.2

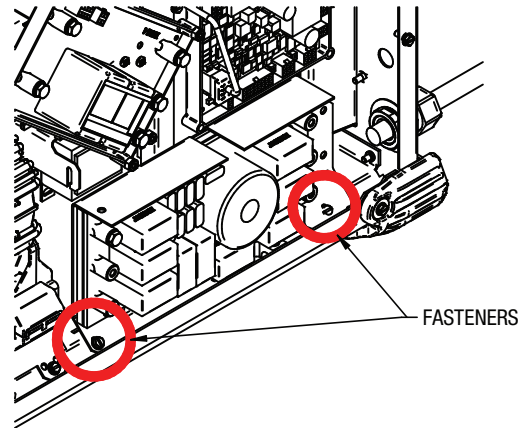

4. Remove EMI Filter Bracket holding EMI Filter to expose ground connection to case bottom. **See FIGURE D.3.**

FIGURE D.3

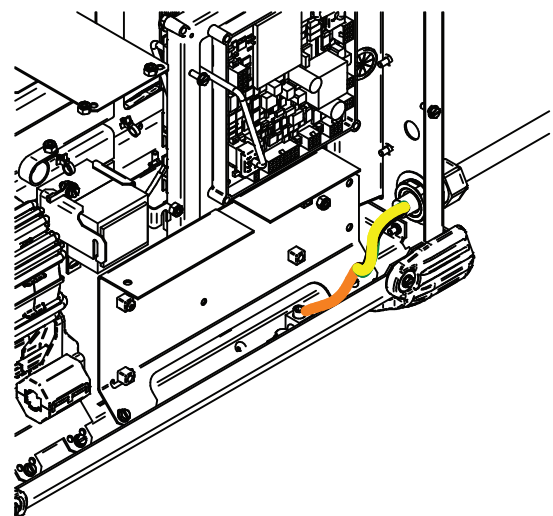

5. Remove 3 phase connection to EMI Filter Board. Be sure to keep the input toriod in the same relative position when reinstalling the EMI Filter Bracket.
6. Remove ground connection by loosening set screw on ground lug.

7. Remove input cord by loosening cable strain relief on case back. See **FIGURE D.4**.

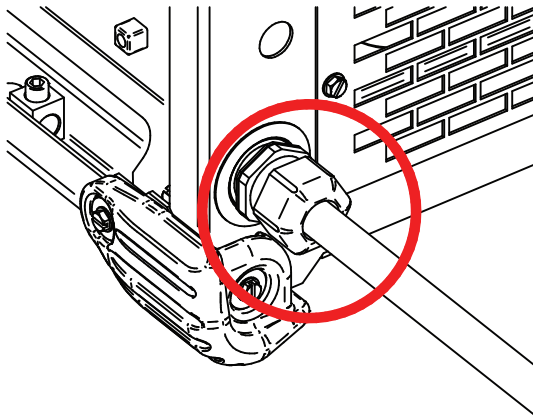
FIGURE D.4

8. Replace input cord with desired cord by connecting 3 input voltage phase leads to B1, B2, and B3 on EMI Filter board. Secure ground lead to lug on case bottom.

TROUBLESHOOTING

WARNING

Service and Repair should only be performed by Lincoln Electric Factory Trained Personnel. Unauthorized repairs performed on this equipment may result in danger to the technician and machine operator and will invalidate your factory warranty. For your safety and to avoid Electrical Shock, please observe all safety notes and precautions detailed throughout this manual.

This Troubleshooting Guide is provided to help you locate and repair possible machine malfunctions. Simply follow the three-step procedure listed below.

Step 1. LOCATE PROBLEM (SYMPTOM).

Look under the column labeled “PROBLEM (SYMPTOMS)”. This column describes possible symptoms that the machine may exhibit. Find the listing that best describes the symptom that the machine is exhibiting.

Step 2. POSSIBLE CAUSE.

The second column labeled “POSSIBLE CAUSE” lists the obvious external possibilities that may contribute to the machine symptom.

Step 3. RECOMMENDED COURSE OF ACTION

This column provides a course of action for the Possible Cause, generally it states to contact your local Lincoln Authorized Field Service Facility.

If you do not understand or are unable to perform the Recommended Course of Action safely, contact your local Lincoln Authorized Field Service Facility.

Observe all additional Safety Guidelines detailed throughout this manual.



If for any reason you do not understand the test procedures or are unable to perform the tests/repairs safely, contact your Lincoln Authorized Service Facility for technical troubleshooting assistance before you proceed.

WWW.LINCOLNELECTRIC.COM/LOCATOR

Observe all Safety Guidelines detailed throughout this manual

PROBLEM	POSSIBLE CAUSE	RECOMMENDED COURSE OF ACTION
Major physical or electrical damage is evident when the sheet metal covers are removed.	1. Contact your local authorized Lincoln Electric Field Service facility for technical assistance.	If all recommended possible areas of misadjustment have been checked and the problem persists, Contact your local Lincoln Authorized Field Service Facility.
Machine won't weld, can't get any output.	1. If the displays show an Err ### see the fault section for corrective action.	
	2. If the thermal symbol is lit refer to the thermal section.	
	3. If the output terminals are in remote control switch to "ON" and check for output voltage. If output voltage is now present check for correct remote control connection and operation.	
Thermal symbol is lit	1. Check for proper fan operation. <ul style="list-style-type: none"> - Check for material blocking intake or exhaust louvers. - Blow air in the rear louvers to clear dirt from the fan. Note: The Fan As Needed circuitry automatically shuts off the fan 5 minutes after welding has stopped.	
	2. Welding output ratings may have been exceeded. Allow the machine to cool down and reset.	
Wire feeder won't work. Apparently no power to wire feeder	1. Check the control cable connectors on the case front of the machine to make sure it is properly connected.	
	2. Check circuit breaker on the case back of the machine. Reset if necessary.	
	3. Check the control cable between the power source and the wire feeder for continuity.	



If for any reason you do not understand the test procedures or are unable to perform the tests/repairs safely, contact your Lincoln Authorized Service Facility for technical troubleshooting assistance before you proceed.

WWW.LINCOLNELECTRIC.COM/LOCATOR

Observe all Safety Guidelines detailed throughout this manual

USING THE STATUS LED TO TROUBLESHOOT SYSTEM PROBLEMS

Errors are displayed on the user interface. In addition, there are status lights on the User Interface PC board and the Switch PC board that contain error sequences.

Included in this section is information about the status lights and some basic troubleshooting charts for both machine and weld performance.

The status lights on the User Interface board, Crossline®, Input board, Control board and the Switch board are dual-color LED's or green LEDs. Normal operation for each is described on the wiring diagram.

Error conditions are indicated in the following chart.

Fault Codes

ERROR CODE#	DESCRIPTION	POSSIBLE CAUSE	CORRECTIVE ACTION
6	Device that controls sequence of the welding operation halted due to an error.	Communication from the Power Source failed before mapping was complete.	Weld Terminals Remote: Re-trigger to recover from error. Weld Terminals Local: Toggle Remote/Local Switch to recover from error.
18	ArcLink Auto-Mapping Failed.	The machine could not properly configure the devices that are attached to it. This configuration problem could be caused by the type of devices that are connected to the machine or a required device that is not connected.	Refer to the Operator's Manual for proper configuration. Verify all devices in the system are properly powered.
21	Device that controls sequence of the welding operation halted due to an error.	A component of the system encountered an error during the welding sequence and caused system to stop. The component with the error could be a wire drive, a user interface or some other part to the system.	Weld Terminals Remote: Re-trigger to recover from error. Weld Terminals Local: Toggle Remote/Local Switch to recover from error.
31	Primary Overcurrent.	Peak current through the transformer primary has exceeded its threshold.	Check the input power (voltage and frequency). Verify that the PC boards and input rectifier are in working condition and proper input power and welding output cable connections. Verify proper connections of main internal power components. Power must be cycled to the machine to reset the error.
36	Thermal Fault	Machine shut off output due to elevated internal temperatures.	1. Check for material blocking intake or exhaust louvers. <ul style="list-style-type: none"> • Blow air in the rear louvers to clear dirt from the fan. Note: The Fan As Needed circuitry automatically shuts off the fan 5 minutes after welding has stopped. 2. Welding output ratings may have been exceeded. Allow the machine to cool down and reset. Measure the thermostats at the Switchboard and replace if defective
45	Output Voltage Limit Exceeded	During OCV, the voltage at the studs exceeded the allowable levels.	IF VRD is enabled, the stud voltage exceeded 35 volts peak. In standard operation, the stud voltage exceeded 113 volts peak. Verify the voltage feedback leads are properly connected inside the machine. Verify the input voltage in within +/- 10% of the nominal value.
213	Communication Fault	CAN communication between the User Interface PC board and the Switch PC Board has been interrupted.	Power must be cycled to the machine to reset the error. Visually inspect the CAN harness to ensure connections and condition. Verify power supply to the User Interface and Switch PC boards. Replace defective assemblies as required.



If for any reason you do not understand the test procedures or are unable to perform the tests/repairs safely, contact your Lincoln Authorized Service Facility for technical troubleshooting assistance before you proceed.

WWW.LINCOLNELECTRIC.COM/LOCATOR

ERROR CODE#	DESCRIPTION	POSSIBLE CAUSE	CORRECTIVE ACTION
711	DC Link Capacitor Over/Under Voltage	The voltage on the main DC link capacitors housed on the switchboard has either gone too high or too low	Verify all three phases of the AC input are connected



If for any reason you do not understand the test procedures or are unable to perform the tests/repairs safely, contact your Lincoln Authorized Service Facility for technical troubleshooting assistance before you proceed.

WWW.LINCOLNELECTRIC.COM/LOCATOR

WIRING DIAGRAM - CODE 13067, 13069, 13071

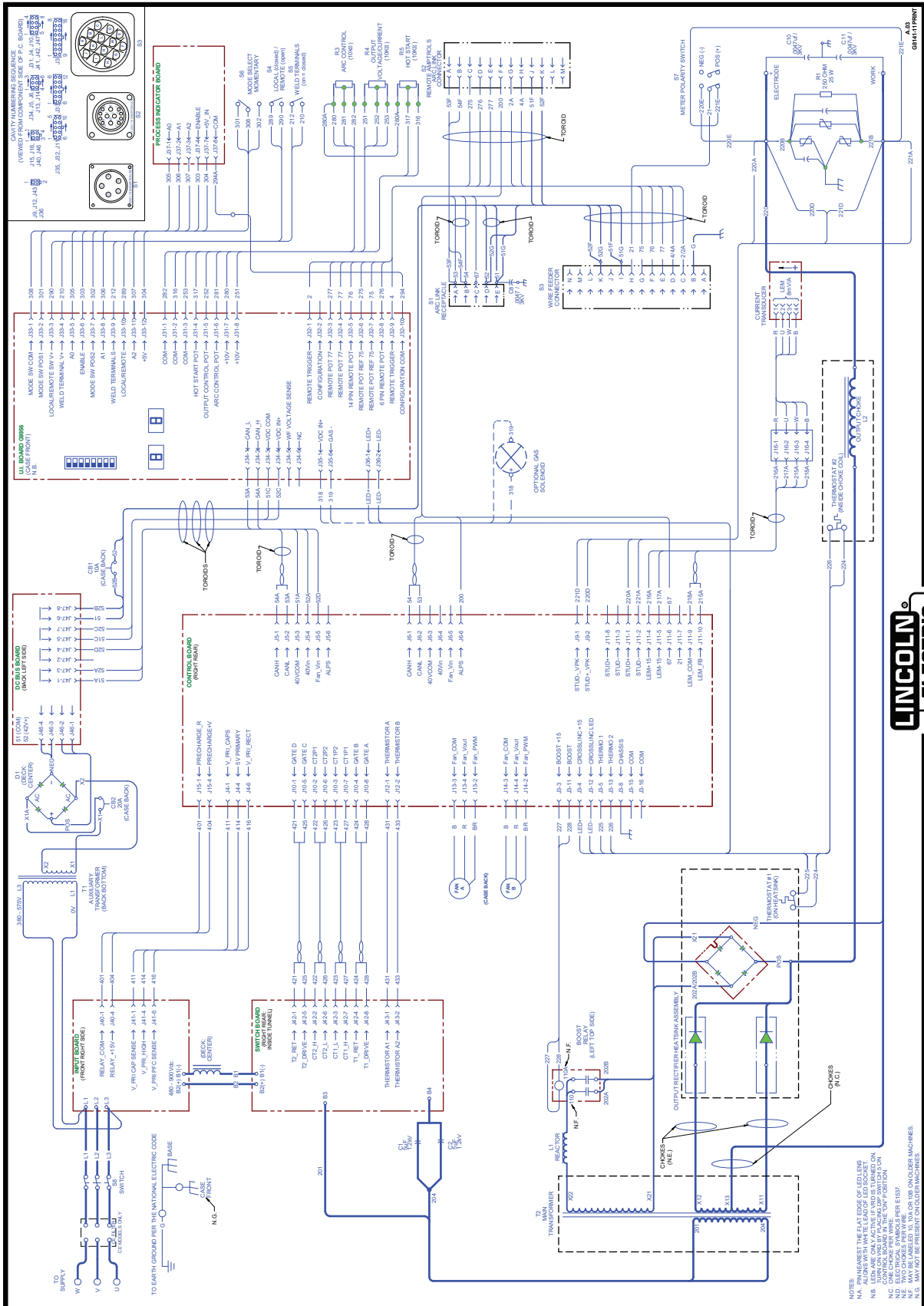

NOTE: This diagram is for reference only. It may not be accurate for all machines covered by this manual. The specific diagram for a particular code is pasted inside the machine on one of the enclosure panels. If the diagram is illegible, write to the Service Department for a replacement. Give the equipment code number.



WIRING DIAGRAM - CODE 13066, 13070, 13073, 13580, 13581, 13582

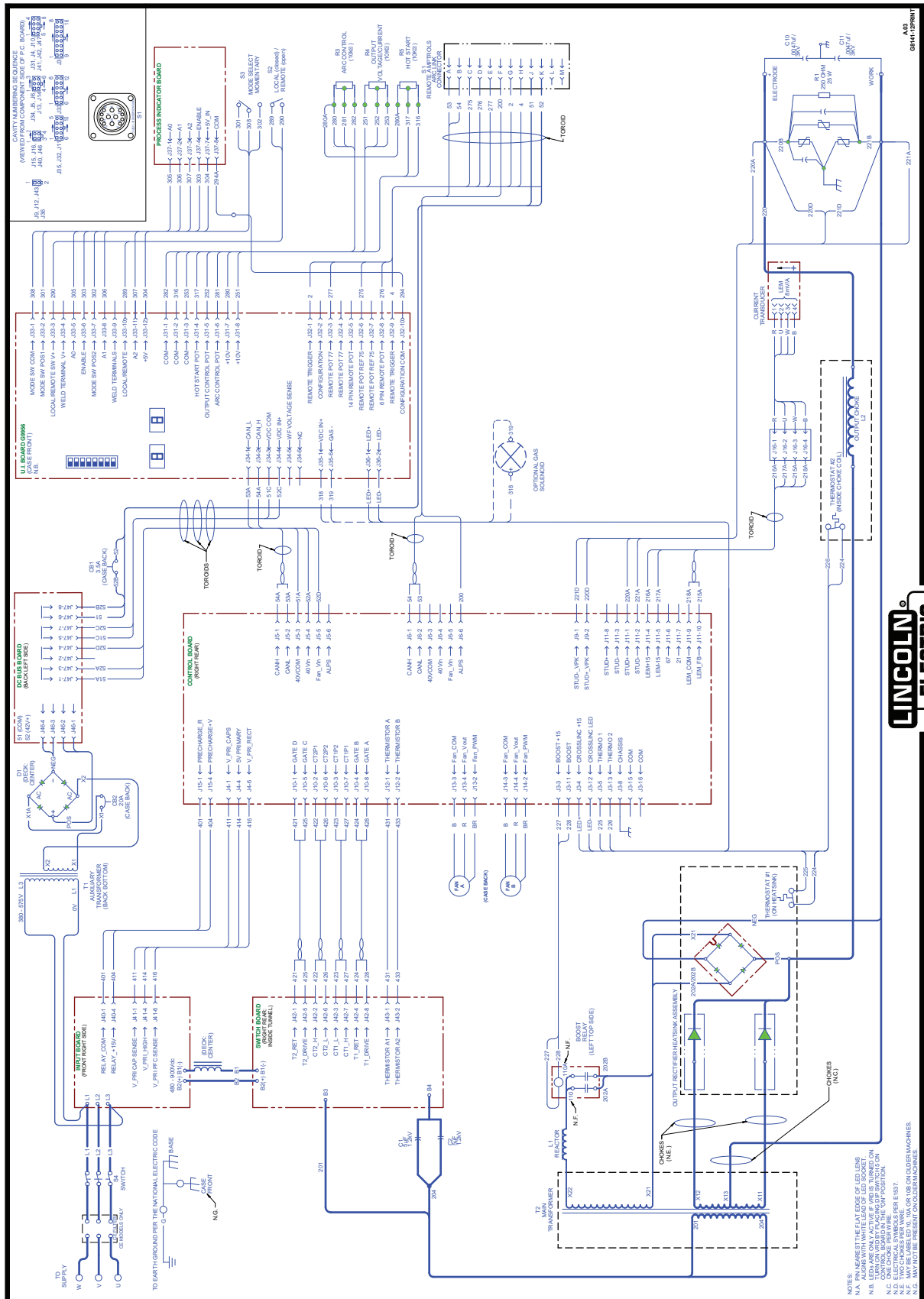

NOTE: This diagram is for reference only. It may not be accurate for all machines covered by this manual. The specific diagram for a particular code is pasted inside the machine on one of the enclosure panels. If the diagram is illegible, write to the Service Department for a replacement. Give the equipment code number.

WIRING DIAGRAM - CODE 13461

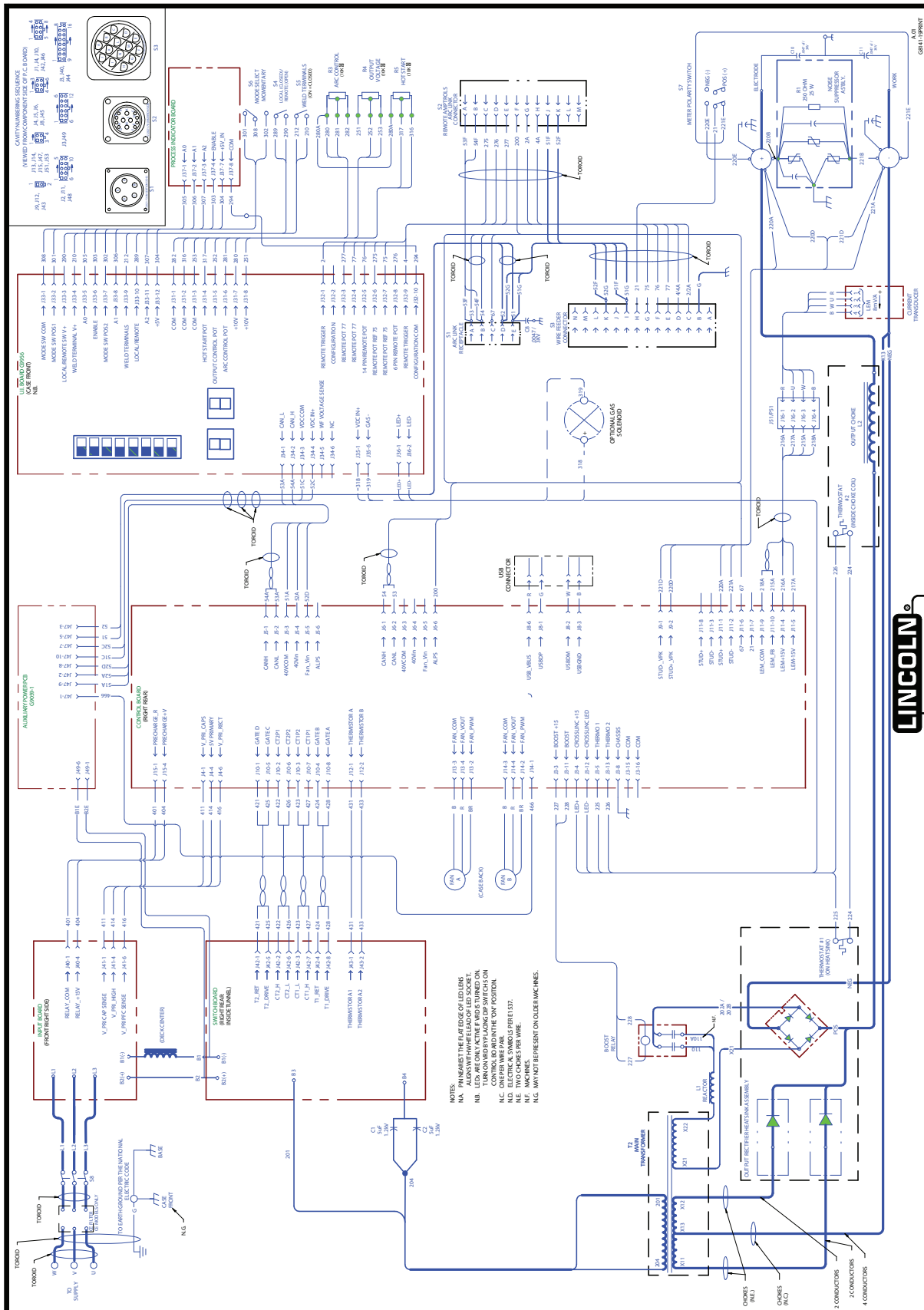

NOTES:
1. ALWAYS TEST THE WIRE COLOR AND GAUGE.
2. ALWAYS USE THE WIRE COLOR AND GAUGE.
3. LEDS ARE ONLY ACTIVE AND RETURNED ON CONTROL BOARD IN THE "ON" POSITION.
4. N.C. ON OFF WIRE PWR.
5. N.E. TWO CHORES PER WIRE.
6. N.G. WIRE NOT REPRESENT ON OLDER MACHINES.

NOTE: This diagram is for reference only. It may not be accurate for all machines covered by this manual. The specific diagram for a particular code is pasted inside the machine on one of the enclosure panels. If the diagram is illegible, write to the Service Department for a replacement. Give the equipment code number.

DIMENSIONAL PRINT

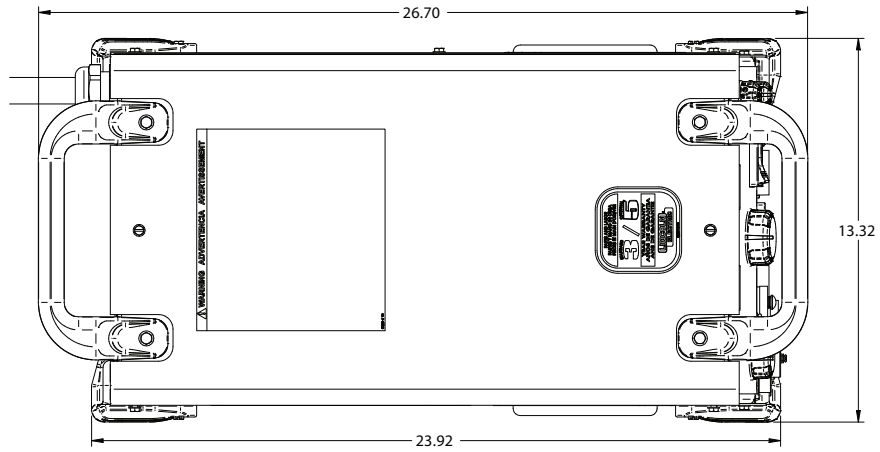

TOP VIEW

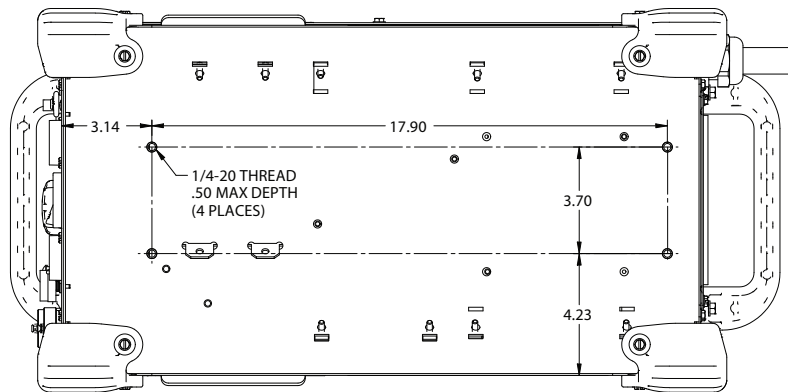
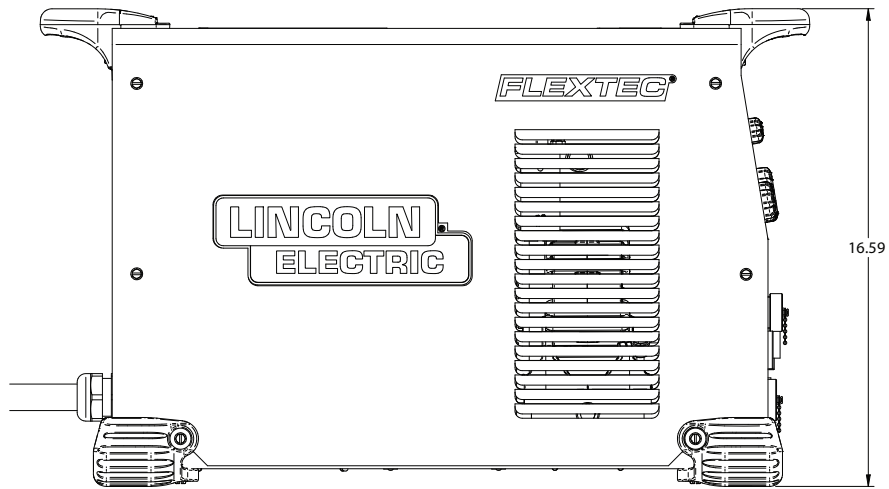

BOTTOM VIEW

			
WARNING	<ul style="list-style-type: none"> Do not touch electrically live parts or electrode with skin or wet clothing. Insulate yourself from work and ground. 	<ul style="list-style-type: none"> Keep flammable materials away. 	<ul style="list-style-type: none"> Wear eye, ear and body protection.
Spanish AVISO DE PRECAUCION	<ul style="list-style-type: none"> No toque las partes o los electrodos bajo carga con la piel o ropa mojada. Aíslese del trabajo y de la tierra. 	<ul style="list-style-type: none"> Mantenga el material combustible fuera del área de trabajo. 	<ul style="list-style-type: none"> Protéjase los ojos, los oídos y el cuerpo.
French ATTENTION	<ul style="list-style-type: none"> Ne laissez ni la peau ni des vêtements mouillés entrer en contact avec des pièces sous tension. Isolez-vous du travail et de la terre. 	<ul style="list-style-type: none"> Gardez à l'écart de tout matériel inflammable. 	<ul style="list-style-type: none"> Protégez vos yeux, vos oreilles et votre corps.
German WARNUNG	<ul style="list-style-type: none"> Berühren Sie keine stromführenden Teile oder Elektroden mit Ihrem Körper oder feuchter Kleidung! Isolieren Sie sich von den Elektroden und dem Erdboden! 	<ul style="list-style-type: none"> Entfernen Sie brennbares Material! 	<ul style="list-style-type: none"> Tragen Sie Augen-, Ohren- und Körperschutz!
Portuguese ATENÇÃO	<ul style="list-style-type: none"> Não toque partes elétricas e electrodos com a pele ou roupa molhada. Isole-se da peça e terra. 	<ul style="list-style-type: none"> Mantenha inflamáveis bem guardados. 	<ul style="list-style-type: none"> Use proteção para a vista, ouvido e corpo.
Japanese 注意事項	<ul style="list-style-type: none"> 通電中の電気部品、又は溶材にヒブやぬれた布で触れないこと。 施工物やアースから身体が絶縁されている様にして下さい。 	<ul style="list-style-type: none"> 燃えやすいものの側での溶接作業は絶対にしてはなりません。 	<ul style="list-style-type: none"> 目、耳及び身体に保護具をして下さい。
Chinese 警告	<ul style="list-style-type: none"> 皮肤或湿衣物切勿接触带电部件及焊条。 使你自已与地面和工件绝缘。 	<ul style="list-style-type: none"> 把一切易燃物品移离工作场所。 	<ul style="list-style-type: none"> 佩戴眼、耳及身体劳动保护用具。
Korean 위험	<ul style="list-style-type: none"> 전도체나 용접봉을 젖은 헝겊 또는 피부로 절대 접촉치 마십시오. 모재와 접지를 접촉치 마십시오. 	<ul style="list-style-type: none"> 인화성 물질을 접근시키지 마십시오. 	<ul style="list-style-type: none"> 눈, 귀와 몸에 보호장구를 착용하십시오.
Arabic تحذير	<ul style="list-style-type: none"> لا تلمس الاجزاء التي يسري فيها التيار الكهربائي أو الألكترود بجسد الجسم أو بالملابس المبللة بالماء. ضع عازلا على جسمك خلال العمل. 	<ul style="list-style-type: none"> ضع المواد القابلة للاشتعال في مكان بعيد. 	<ul style="list-style-type: none"> ضع أدوات وملابس واقية على عينيك وأذنيك وجسمك.

READ AND UNDERSTAND THE MANUFACTURER'S INSTRUCTION FOR THIS EQUIPMENT AND THE CONSUMABLES TO BE USED AND FOLLOW YOUR EMPLOYER'S SAFETY PRACTICES.

SE RECOMIENDA LEER Y ENTENDER LAS INSTRUCCIONES DEL FABRICANTE PARA EL USO DE ESTE EQUIPO Y LOS CONSUMIBLES QUE VA A UTILIZAR, SIGA LAS MEDIDAS DE SEGURIDAD DE SU SUPERVISOR.

LISEZ ET COMPRENEZ LES INSTRUCTIONS DU FABRICANT EN CE QUI REGARDE CET EQUIPMENT ET LES PRODUITS A ETRE EMPLOYES ET SUIVEZ LES PROCEDURES DE SECURITE DE VOTRE EMPLOYEUR.

LESEN SIE UND BEFOLGEN SIE DIE BETRIEBSANLEITUNG DER ANLAGE UND DEN ELEKTRODENEINSATZ DES HERSTELLERS. DIE UNFALLVERHÜTUNGSVORSCHRIFTEN DES ARBEITGEBERS SIND EBENFALLS ZU BEACHTEN.

			
<ul style="list-style-type: none"> ● Keep your head out of fumes. ● Use ventilation or exhaust to remove fumes from breathing zone. 	<ul style="list-style-type: none"> ● Turn power off before servicing. 	<ul style="list-style-type: none"> ● Do not operate with panel open or guards off. 	WARNING
<ul style="list-style-type: none"> ● Los humos fuera de la zona de respiración. ● Mantenga la cabeza fuera de los humos. Utilice ventilación o aspiración para gases. 	<ul style="list-style-type: none"> ● Desconectar el cable de alimentación de poder de la máquina antes de iniciar cualquier servicio. 	<ul style="list-style-type: none"> ● No operar con panel abierto o guardas quitadas. 	Spanish AVISO DE PRECAUCION
<ul style="list-style-type: none"> ● Gardez la tête à l'écart des fumées. ● Utilisez un ventilateur ou un aspirateur pour ôter les fumées des zones de travail. 	<ul style="list-style-type: none"> ● Débranchez le courant avant l'entretien. 	<ul style="list-style-type: none"> ● N'opérez pas avec les panneaux ouverts ou avec les dispositifs de protection enlevés. 	French ATTENTION
<ul style="list-style-type: none"> ● Vermeiden Sie das Einatmen von Schweißrauch! ● Sorgen Sie für gute Be- und Entlüftung des Arbeitsplatzes! 	<ul style="list-style-type: none"> ● Strom vor Wartungsarbeiten abschalten! (Netzstrom völlig öffnen; Maschine anhalten!) 	<ul style="list-style-type: none"> ● Anlage nie ohne Schutzgehäuse oder Innenschutzverkleidung in Betrieb setzen! 	German WARNUNG
<ul style="list-style-type: none"> ● Mantenha seu rosto da fumaça. ● Use ventilação e exaustão para remover fumo da zona respiratória. 	<ul style="list-style-type: none"> ● Não opere com as tampas removidas. ● Desligue a corrente antes de fazer serviço. ● Não toque as partes elétricas nuas. 	<ul style="list-style-type: none"> ● Mantenha-se afastado das partes moventes. ● Não opere com os painéis abertos ou guardas removidas. 	Portuguese ATENÇÃO
<ul style="list-style-type: none"> ● ヒュームから頭を離すようにして下さい。 ● 換気や排煙に十分留意して下さい。 	<ul style="list-style-type: none"> ● メンテナンス・サービスに取りかかる際には、まず電源スイッチを必ず切ってください。 	<ul style="list-style-type: none"> ● パネルやカバーを取り外したまま機械操作をしないで下さい。 	Japanese 注意事項
<ul style="list-style-type: none"> ● 頭部遠離煙霧。 ● 在呼吸區使用通風或排風器除煙。 	<ul style="list-style-type: none"> ● 維修前切斷電源。 	<ul style="list-style-type: none"> ● 儀表板打開或沒有安全罩時不準作業。 	Chinese 警告
<ul style="list-style-type: none"> ● 얼굴로부터 용접가스를 멀리하십시오. ● 호흡지역으로부터 용접가스를 제거하기 위해 가스제거기나 통풍기를 사용하십시오. 	<ul style="list-style-type: none"> ● 보수전에 전원을 차단하십시오. 	<ul style="list-style-type: none"> ● 판넬이 열린 상태로 작동치 마십시오. 	Korean 위험
<ul style="list-style-type: none"> ● ابعِد رأسك بعيداً عن الدخان. ● استعمل التهوية أو جهاز ضغط الدخان للخارج لكي تبعد الدخان عن المنطقة التي تتنفس فيها. 	<ul style="list-style-type: none"> ● اقطع التيار الكهربائي قبل القيام بأية صيانة. 	<ul style="list-style-type: none"> ● لا تشغيل هذا الجهاز اذا كانت الاغطية الحديدية الواقية ليست عليه. 	Arabic تحذير

LEIA E COMPREENDA AS INSTRUÇÕES DO FABRICANTE PARA ESTE EQUIPAMENTO E AS PARTES DE USO, E SIGA AS PRÁTICAS DE SEGURANÇA DO EMPREGADOR.

使う機械や溶材のメーカーの指示書をよく読み、まず理解して下さい。そして貴社の安全規定に従って下さい。

請詳細閱讀並理解製造廠提供的說明以及應該使用的銀焊材料，並請遵守貴方的有關於勞動保護規定。

이 제품에 동봉된 작업지침서를 숙자하시고 귀사의 작업자 안전수칙을 준수하시기 바랍니다.

اقرأ بتمعن وافهم تعليمات المصنع المنتج لهذه المعدات والمواد قبل استعمالها واتبع تعليمات الوقاية لصاحب العمل.

CUSTOMER ASSISTANCE POLICY

The business of Lincoln Electric is manufacturing and selling high quality welding equipment, automated welding systems, consumables, and cutting equipment. Our challenge is to meet the needs of our customers, who are experts in their fields, and to exceed their expectations. On occasion, purchasers may ask Lincoln Electric for information or technical information about their use of our products. Our employees respond to inquiries to the best of their ability based on information and specifications provided to them by the customers and the knowledge they may have concerning the application. Our employees, however, are not in a position to verify the information provided or to evaluate the engineering requirements for the particular weldment, or to provide engineering advice in relation to a specific situation or application. Accordingly, Lincoln Electric does not warrant or guarantee or assume any liability with respect to such information or communications. Moreover, the provision of such information or technical information does not create, expand, or alter any warranty on our products. Any express or implied warranty that might arise from the information or technical information, including any implied warranty of merchantability or any warranty of fitness for any customers' particular purpose or any other equivalent or similar warranty is specifically disclaimed.

Lincoln Electric is a responsive manufacturer, but the definition of specifications, and the selection and use of specific products sold by Lincoln Electric is solely within the control of, and remains the sole responsibility of the customer. Many variables beyond the control of Lincoln Electric affect the results obtained in applying these types of fabrication methods and service requirements.

WELD FUME CONTROL EQUIPMENT

The operation of welding fume control equipment is affected by various factors including proper use and positioning of the equipment, maintenance of the equipment and the specific welding procedure and application involved. Worker exposure level should be checked upon installation and periodically thereafter to be certain it is within applicable OSHA PEL and ACGIH TLV limits.



THE LINCOLN ELECTRIC COMPANY

22801 St. Clair Avenue • Cleveland, OH • 44117-1199 • U.S.A.
Phone: +1.216.481.8100 • www.lincolnelectric.com